

**Panasonic**

Personal Facsimile

Model No. **KX-F580**

# OPERATING INSTRUCTIONS

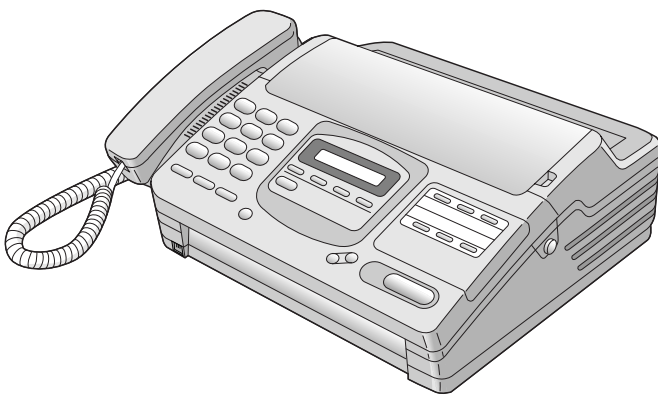

Please read these Operating Instructions before using the unit and save for future reference.

**FOR OPERATION ASSISTANCE,  
CALL 1-800-HELP-FAX (1-800-435-7329)**

- This product is designed for use in the United States of America, and may not operate in other countries. (See page 60 for more details.)
- Este producto ha sido diseñado para su uso en los Estados Unidos de América, y puede no funcionar correctamente en otros países. (Consulte la página 60 para tener más detalles.)

## Contents

---

|                                               |       |
|-----------------------------------------------|-------|
| Installation and Connection . . . . .         | p. 6  |
| Initial Preparation . . . . .                 | p. 11 |
| Basic Operations . . . . .                    | p. 17 |
| Advanced Operations . . . . .                 | p. 26 |
| Troubleshooting and<br>Routine Care . . . . . | p. 49 |
| General Information . . . . .                 | p. 56 |

Thank you for purchasing the Panasonic Facsimile.

## Things you should keep records of

Attach your sales receipt here

### For your future reference

Date of purchase \_\_\_\_\_ Serial No. \_\_\_\_\_  
(found on the bottom of the unit)

Dealer's name and address \_\_\_\_\_

Dealer's telephone number \_\_\_\_\_

### Caution:

The Telephone Protection Act of 1991 requires the following information to be clearly stated either at the top or bottom margin of the first message page when transmitting messages via telephone facsimile;

- Date and time of transmission,
- Identification of the business, entity or person(s) sending the facsimile, and
- Telephone number of the business, entity or person(s).



To program this information into your facsimile machine, complete all the instructions on pages 11 through 13.

### Copyright:

This manual is copyrighted by Kyushu Matsushita Electric Co., Ltd. (KME) and its licensee. Under the copyright laws, this manual may not be reproduced in any form, in whole or part, without the prior written consent of KME and its licensee.

© Kyushu Matsushita Electric Co., Ltd. 1996

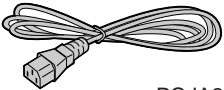
## Included accessories (To order, call toll free 1-800-332-5368.)

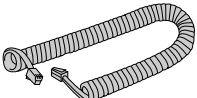
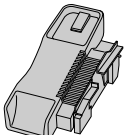
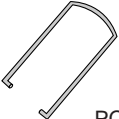
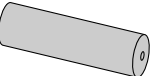
|                                                                                                                                              |                                                                                                                                                    |                                                                                                                                                                                      |                                                                                                                                             |
|----------------------------------------------------------------------------------------------------------------------------------------------|----------------------------------------------------------------------------------------------------------------------------------------------------|--------------------------------------------------------------------------------------------------------------------------------------------------------------------------------------|---------------------------------------------------------------------------------------------------------------------------------------------|
| Power cord . . . . . 1 pc.<br>(p. 10)<br><br>PQJA200Z     | Telephone line<br>cord. . . . . 1 pc.<br>(p. 10)<br><br>PQJA59V | Handset . . . . . 1 pc.<br>(p. 8)<br><br>PFJXE0108Z                                               | Handset cord . . . . . 1 pc.<br>(p. 8)<br><br>PQJA212N |
| Handset cradle . . . . . 1 pc.<br>(p. 8)<br><br>PFYAF780M | Paper stacker. . . . . 1 pc.<br>(p. 9)<br><br>PQUS10136Z        | Recording paper. . . 1 pc.<br>(p. 9)<br> —See page 59 for replacement<br>of the recording paper. |                                                                                                                                             |

- If any items are missing, check with place of purchase.
- The part numbers listed above are subject to change without notice.
- Save the original carton and packaging.

# Important safety instructions

When using this product, basic safety precautions should always be followed to reduce the risk of fire, electric shock, and injury to persons, including the following:

1. Read and understand all instructions.
2. Follow all warnings and instructions marked on this product.
3. Unplug this product from wall outlets before cleaning. Do not use liquid or aerosol cleaners. Use a damp cloth for cleaning.
4. Do not use this product near water, for example, near a bath tub, wash bowl, kitchen sink, or laundry tub, in a wet basement, or near a swimming pool.
5. Do not place this product on an unstable cart, stand or table. The product may fall, causing serious damage to the product or personal injury.
6. Slots and openings in the cabinet and the back or bottom are provided for ventilation, to protect it from overheating. These openings must not be blocked or covered. The openings should never be blocked by placing the product on the bed, sofa rug, or other similar surface. This product should never be placed near or over a radiator or heat register. This product should not be placed in a built-in installation unless proper ventilation is provided.
7. This product should be operated only from the type of power source indicated on the marking label. If you are not sure of the type of power supplied to your home, consult your dealer or local power company.
8. This product is equipped with a three wire grounding type plug, a plug having a third (grounding) pin. This plug will only fit into a grounding type power outlet. This is a safety feature. If you are unable to insert the plug into the outlet, contact your electrician to replace your obsolete outlet. Do not defeat the safety purpose of the grounding type plug.
9. Do not allow anything to rest on the power cord. Do not locate this product where the cord could be damaged by people walking on it.
10. Do not overload wall outlets and extension cords as this can result in the risk of fire or electric shock.
11. Never push objects of any kind into this product through cabinet slots as they may touch dangerous voltage points or short out parts that could result in a risk of fire or electric shock. Never spill liquid of any kind on the product.
12. To reduce the risk of electric shock, do not disassemble this product, but take it to an authorized servicenter when some service or repair work is required. Opening or removing covers may expose you to dangerous voltages or other risks. Incorrect reassembly can cause electric shock when the appliance is subsequently used.
13. Unplug this product from the wall outlet and refer servicing to an authorized servicenter under the following conditions:
  - A. When the power supply cord or plug is damaged or frayed.
  - B. If liquid has been spilled into the product.
  - C. If the product has been exposed to rain or water.
  - D. If the product does not work normally by following the operating instructions. Adjust only those controls, that are covered by the operating instructions because improper adjustment of other controls may result in damage and will often require extensive work by an authorized technician to restore the product to normal operation.
  - E. If the product has been dropped or the cabinet has been damaged.
  - F. If the product exhibits a distinct change in performance.
14. Avoid using a telephone (other than a cordless type) during an electrical storm. There may be a remote risk of electric shock from lightning.
15. Do not use the telephone to report a gas leak in the vicinity of the leak.

## SAVE THESE INSTRUCTIONS

### INSTALLATION:

1. Never install telephone wiring during a lightning storm.
2. Never install telephone jacks in wet locations unless the jack is specifically designed for wet locations.
3. Never touch uninsulated telephone wires or terminals unless the telephone line has been disconnected at the network interface.
4. Use caution when installing or modifying telephone lines.

### WARNING:

To prevent the risk of fire or electrical shock, do not expose this product to rain or any type of moisture.

### OTHER INFORMATION

- Keep the unit away from electrical noise-generating devices, such as fluorescent lamps and motors.
- The unit should be kept free from dust, moisture, high temperature, and vibration.
- The unit should not be exposed to direct sunlight.
- Do not place heavy objects on top of this unit.
- Do not damage the power cord.
- Do not touch the plug with wet hands.
- Do not use benzine, thinner, or any abrasive powder, to clean the cabinet. Wipe it with a soft cloth.

# Table of Contents

## Installation and Connection

|                            |    |
|----------------------------|----|
| Location of controls ..... | 6  |
| Installing your unit ..... | 8  |
| Connections .....          | 10 |

## Initial Preparation

|                                                                   |    |
|-------------------------------------------------------------------|----|
| Setting the date, time, logo and facsimile telephone number ..... | 11 |
| Selecting the receive mode .....                                  | 14 |
| Adjusting volumes .....                                           | 16 |

## Basic Operations

|                              |    |
|------------------------------|----|
| Making voice calls .....     | 17 |
| Answering voice calls .....  | 17 |
| Transmitting documents ..... | 18 |
| Receiving documents .....    | 20 |
| Making a copy .....          | 25 |

## Advanced Operations

### *Automatic dialing*

|                                                      |    |
|------------------------------------------------------|----|
| Storing phone numbers for automatic dialing .....    | 26 |
| Making voice calls using automatic dialing .....     | 27 |
| Transmitting documents using automatic dialing ..... | 27 |
| Electronic telephone directory .....                 | 28 |

### *Telephone*

|                                                                                           |    |
|-------------------------------------------------------------------------------------------|----|
| Voice contact (talking to the caller during or after fax reception or transmission) ..... | 29 |
| TONE, FLASH and REDIAL/PAUSE buttons .....                                                | 30 |

### *Facsimile*

|                                                                                 |    |
|---------------------------------------------------------------------------------|----|
| Polling (retrieving fax documents) .....                                        | 31 |
| Delayed transmission (sending a fax at a later time) .....                      | 32 |
| Sending documents overseas .....                                                | 33 |
| Remote fax receiving (using an extension to receive a fax message) .....        | 34 |
| Junk mail prohibitor (preventing the reception of unwanted fax documents) ..... | 35 |
| Receiving with distinctive ring service .....                                   | 36 |
| Signaling your pager that you have received a fax document .....                | 37 |

**Special setting**

Using an external telephone answering machine ..... 38  
 Changing the logo print position ..... 42  
 Changing the display contrast ..... 42  
 Setting the friendly reception..... 43  
 Setting the handset switch ..... 43  
 Resetting the advanced features ..... 44

**Others**

Summary of user programmable features ..... 45  
 Printing reports and lists..... 46

**Troubleshooting and Routine Care**

Error messages on the display ..... 49  
 Before requesting help ..... 50  
 Clearing a recording paper jam ..... 52  
 Clearing a document jam ..... 53  
 Adjusting the feeder pressure ..... 54  
 Removing the handset cradle ..... 54  
 Cleaning the inside of the unit ..... 55

**General Information**

FCC information ..... 56  
 Limited warranty ..... 57  
 Service center directory ..... 58  
 Information for users ..... 59  
 Accessory order information ..... 59  
 Specifications ..... 60  
 Speed dialer list ..... 61  
 Index..... 63

# Location of controls

---

---

## Front view

---

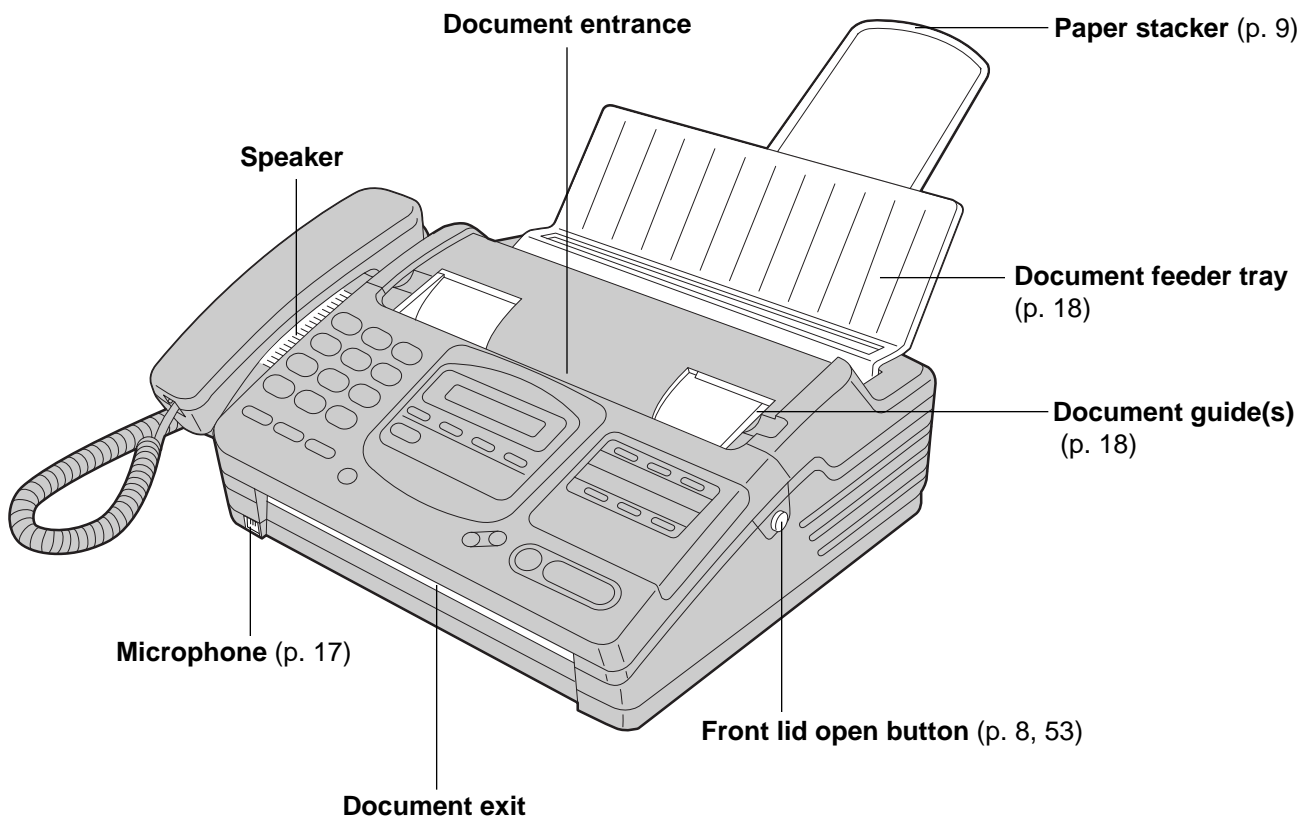

# Control panel

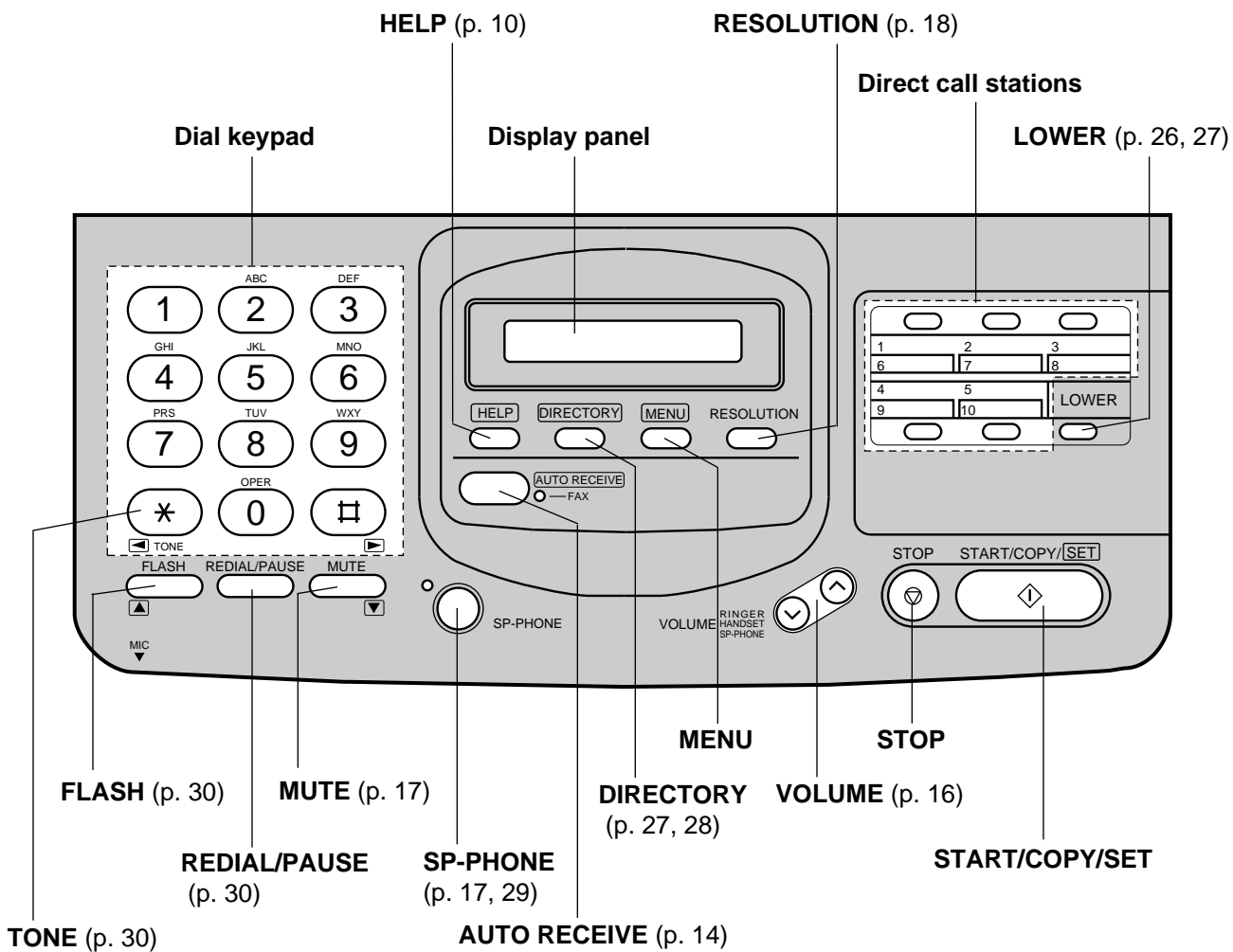

# Installing your unit

## Installing the handset cradle

If you want to use this unit with a handset, install the handset and handset cradle.

- To save space or to use the unit mainly for faxes, you may remove the handset cradle. Even if the handset and handset cradle are not installed, you can make or answer calls using the SP-PHONE button. When you do not use the handset and handset cradle, see pages 43 and 54.

**1** Connect the handset cord.

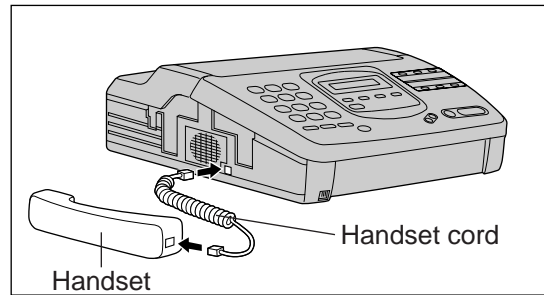

**2** **A** Open the front lid by pressing the front lid open button.  
**B** Open the back lid by lifting up the tabs located on both sides.

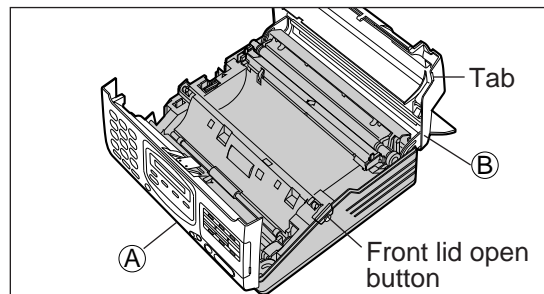

**3** Insert the handset cradle by matching the triangles.

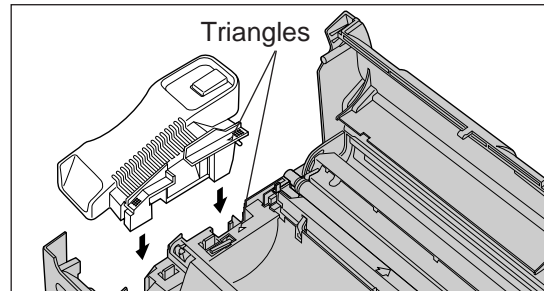

**4** Press down on the  marked on the handset cradle until it clicks into place.  
• **Make sure the two hooks lock the handset cradle firmly.**

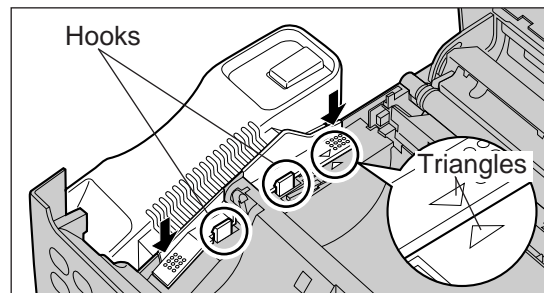

**5** Place the handset on the handset cradle and close the lids securely.  
• If the following message is displayed when the unit is turned on, the handset cradle is not installed correctly.

CHECK CRADLE

Check step 4 again.

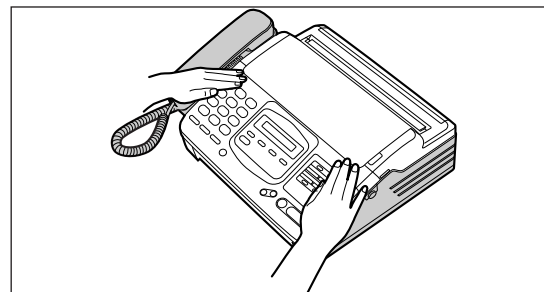



## Installing the recording paper

- 1
  - Ⓐ Open the back lid by lifting up the tabs located on both sides.
  - Ⓑ Install a recording paper roll in the unit.
    - Make sure that the shiny side of the paper is facing down and there is no slack, tape, or glue residue on the paper roll.

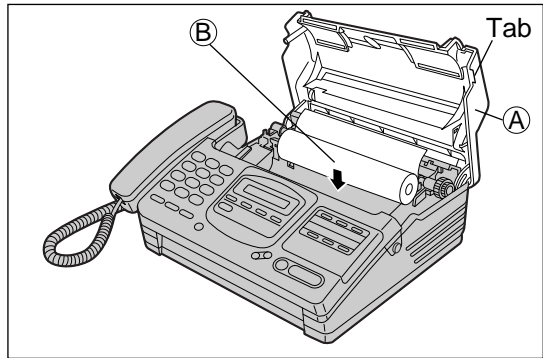
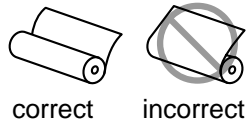

- 2 Insert the leading edge of the recording paper between the recording paper roller and the silver plate.

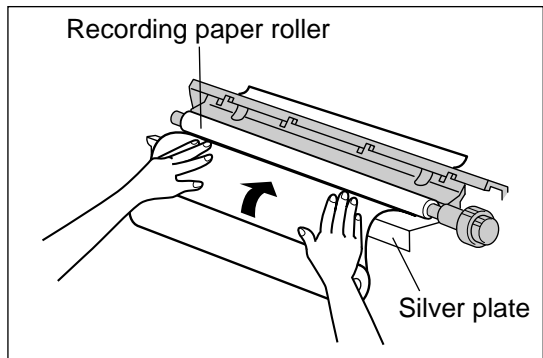

- 3 Close the back lid by gently pressing down on both ends.

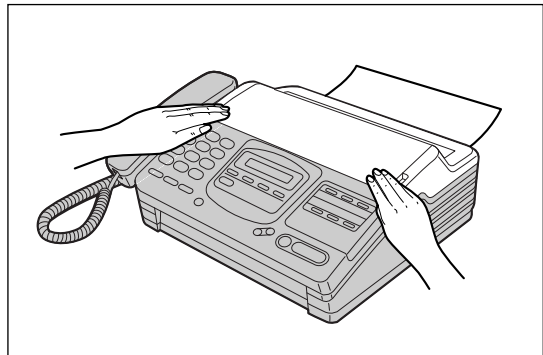

### Note:

- Only use the included roll of paper or specified recording paper, or else the print quality may be affected and/or excessive thermal head wear may occur.
- The beginning of some recording paper rolls are secured with glue or tape. Cut approximately 150 mm (6 inches) from the new roll of paper prior to installation.
- To order recording paper, see page 59.

## Installing the paper stacker

Install the paper stacker.

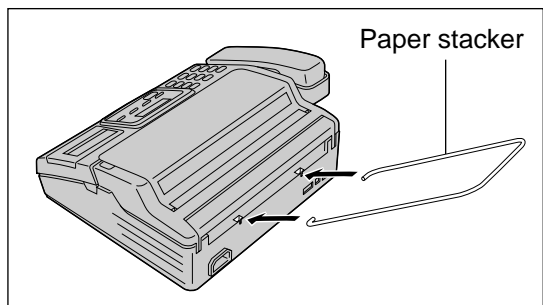

# Connections

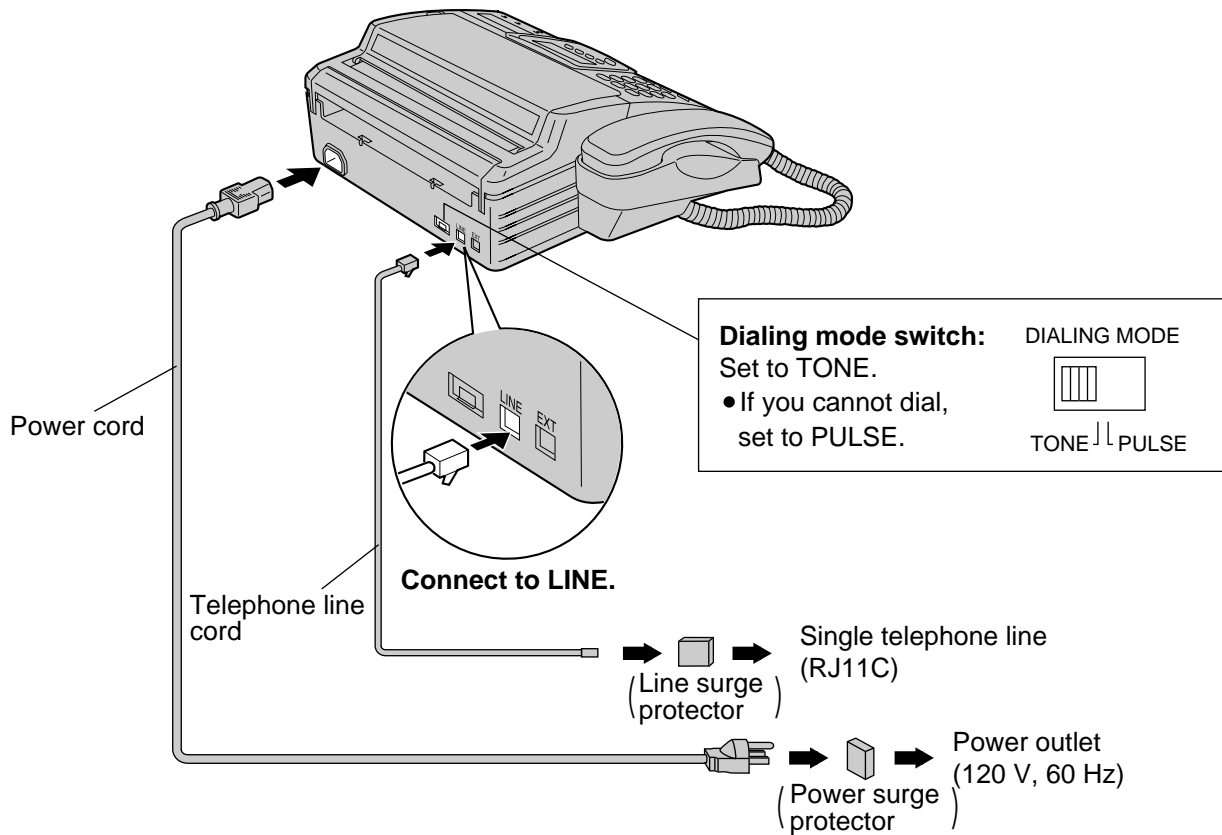

**Note:**

- For additional equipment protection, we recommend the use of a surge protector. The following types are available; TELESPIKE BLOK MODEL TSB (TRIPPE MFG. CO.), SPIKE BLOK MODEL SK6-0 (TRIPPE MFG. CO.), SUPER MAX (PANAMAX) or MP1 (ITW LINX).
- You can connect an extension phone or a telephone answering machine to the unit on the external telephone jack (EXT). See page 38.
- When you operate this product, the power outlet should be near the product and easily accessible.

**Helpful hint:**

- If assistance is needed, press **HELP**. The unit will print a quick reference.

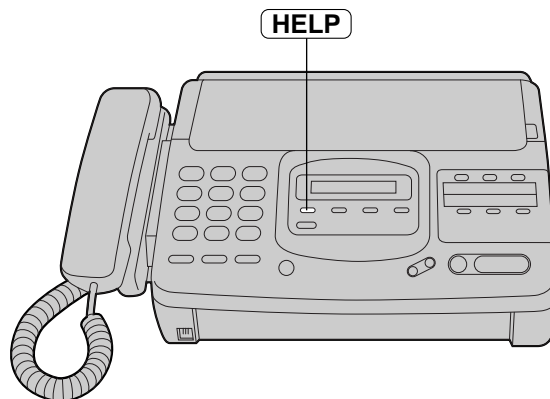

# Setting the date, time, logo and facsimile telephone number

Before using your unit, program the correct date and time, your logo and your facsimile telephone number.

This information will be printed on the top of the each page transmitted from your unit.  
To change the print position, see page 42.

## Setting the date and time

- 1 Press **MENU**.  
**SYSTEM SET UP**
- 2 Press **#**, then **0 1**.  
**SET DATE & TIME**
- 3 Press **START/COPY/SET**.
- 4 Enter the correct month/day/year/hour/minute by selecting each 2 digits.  
Then press **\*** for AM or **#** for PM.  
**Example:** Aug. 10 1996, 3:00PM  
Press **0 8 1 0 9 6 0 3 0 0**,  
then press **#** for PM.
- 5 Press **START/COPY/SET**.
- 6 Press **MENU**.

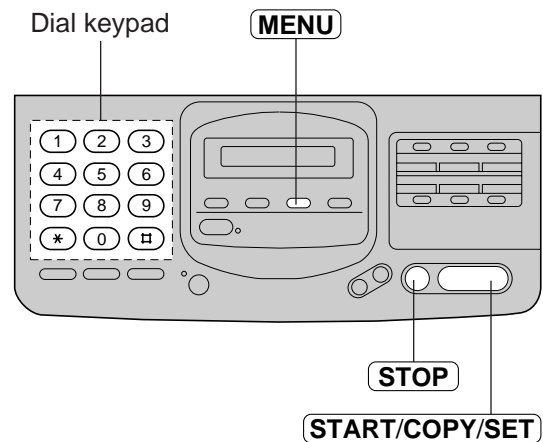

### Note:

- If you make a mistake while programming, press **STOP** then make corrections.
- The accuracy of the clock will be approximately  $\pm 60$  seconds a month.

## Setting your logo

Usually the logo is a company, division or personal name in an abbreviated form.

- 1 Press **MENU**.  
SYSTEM SET UP
- 2 Press **#**, then **0 2**.  
YOUR LOGO
- 3 Press **START/COPY/SET**.  
LOGO=
- 4 Enter your logo up to 30 characters.  
•Refer to the instructions on page 13.
- 5 Press **START/COPY/SET**.
- 6 Press **MENU**.

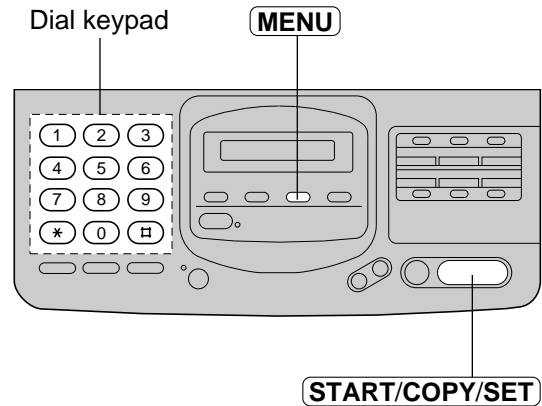

## Setting your facsimile telephone number

- 1 Press **MENU**.  
SYSTEM SET UP
- 2 Press **#**, then **0 3**.  
YOUR TEL NO.
- 3 Press **START/COPY/SET**.  
No. =
- 4 Enter your facsimile telephone number up to 20 digits.  
•The **#** button inserts a space and the **\*** button a "+".  
•If you make a mistake, press **STOP** to delete the wrong number to the left of the cursor.
- 5 Press **START/COPY/SET**.
- 6 Press **MENU**.

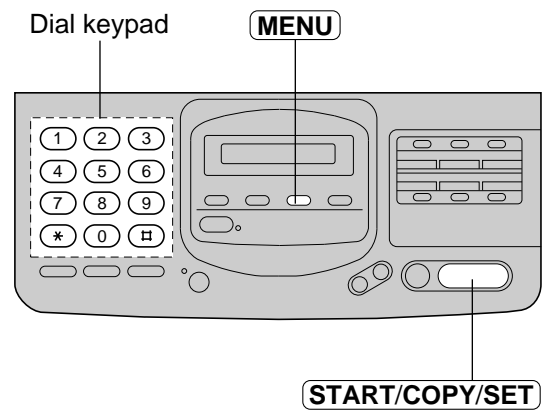

# How to enter characters and symbols

The dial keypad and the direct call stations can be used as character input keys and command keys. Pressing 0-9 and direct call station 1 will alternately select a character as shown below.

| Keys | Number of times                                         |   |   |   |   |   |   |   |    |    |    |    |    |
|------|---------------------------------------------------------|---|---|---|---|---|---|---|----|----|----|----|----|
|      | 1                                                       | 2 | 3 | 4 | 5 | 6 | 7 | 8 | 9  | 10 | 11 | 12 | 13 |
| 1    | 1                                                       | [ | ] | { | } | + | - | / | =  | ,  | .  | _  | '  |
| 2    | A                                                       | B | C | a | b | c | 2 |   |    |    |    |    |    |
| 3    | D                                                       | E | F | d | e | f | 3 |   |    |    |    |    |    |
| 4    | G                                                       | H | I | g | h | i | 4 |   |    |    |    |    |    |
| 5    | J                                                       | K | L | j | k | l | 5 |   |    |    |    |    |    |
| 6    | M                                                       | N | O | m | n | o | 6 |   |    |    |    |    |    |
| 7    | P                                                       | Q | R | S | p | q | r | s | 7  |    |    |    |    |
| 8    | T                                                       | U | V | t | u | v | 8 |   |    |    |    |    |    |
| 9    | W                                                       | X | Y | Z | w | x | y | z | 9  |    |    |    |    |
| 0    | 0                                                       | ( | ) | < | > | ! | " | # | \$ | %  | &  | ¥  |    |
|      | :                                                       | ; | ? |   | * | @ | ^ | ' | □  |    |    |    |    |
|      | INSERT key (Used to insert one character or one space.) |   |   |   |   |   |   |   |    |    |    |    |    |
|      | DELETE key (Used to delete one character.)              |   |   |   |   |   |   |   |    |    |    |    |    |
|      | SPACE key (Used to replace one character with a space.) |   |   |   |   |   |   |   |    |    |    |    |    |
|      | ▶ key (Used to move the cursor to the right.)           |   |   |   |   |   |   |   |    |    |    |    |    |
|      | ◀ key (Used to move the cursor to the left.)            |   |   |   |   |   |   |   |    |    |    |    |    |

For example, when entering "Mike" as your logo:

1 Press **6**.

LOGO=M

3 Press **5** five times.

LOGO=Mik

2 Press **4** six times.

LOGO=Mi

4 Press **3** five times.

LOGO=Mike

## Note:

- If you use the same number key continuously to enter the next character, press **▶** to move the cursor.

## To correct a mistake while programming

Use **▶** and **\*** to move the cursor to the incorrect character, then make the correction.

or

Press **STOP** to delete the character to the left of the cursor.

## To see the layout of the direct call station keys

Remove the directory card cover with a pencil or similar object and turn the directory card over.

# Selecting the receive mode

The unit combines the functions of facsimile and telephone as well as providing a TAM (Telephone Answering Machine) interface. This unit has two types of receive modes; AUTO RECEIVE and MANUAL RECEIVE.

—When you are unable to answer, set the AUTO RECEIVE mode.

—When you are available, set the MANUAL RECEIVE mode.

Press **AUTO RECEIVE** to switch to the desired mode.

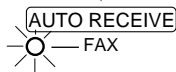
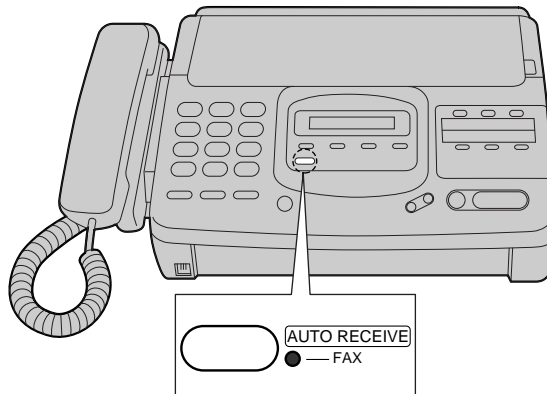

## AUTO RECEIVE mode

The FAX indicator light goes on.

### FAX mode: (pre-selected setting)

Select this mode when you use the unit solely as a fax machine (see page 21).

Display: FAX MODE

- You can select the EXT.TAM mode instead of the FAX mode as an AUTO RECEIVE mode (page 15).

### EXT. TAM mode:

Select this mode when you connect a telephone answering machine to the external telephone (EXT.) jack and leave the home or office (see page 38).

- If your external telephone does not have an answering/recording feature, do not select this mode. We recommend that you select the TEL mode.

Display: EXT.TAM MODE

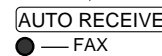

## MANUAL RECEIVE mode

The FAX indicator light goes off.

### TEL mode: (pre-selected setting)

Select this mode when you wish to answer all calls manually.

Display: TEL MODE

- When no one answers an incoming call by 15 rings, the unit will temporarily activate the fax function to receive documents.

- You can select the TEL/FAX mode instead of the TEL mode as an MANUAL RECEIVE mode (page 15).

### TEL/FAX mode:

Select this mode when you are near the unit and do not want to hear the unit ring when faxes are received but wish to answer voice calls (see page 22).

Display: TEL/FAX MODE

## Note:

- Regardless of the mode you select, you can always place calls and send faxes.

## Changing the setting of the AUTO RECEIVE mode \_\_\_\_\_

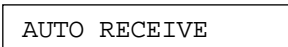
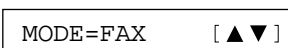

You can select either FAX mode (pre-selected setting) or EXT.TAM mode in the AUTO RECEIVE mode. If you want to change the setting, follow the steps below.

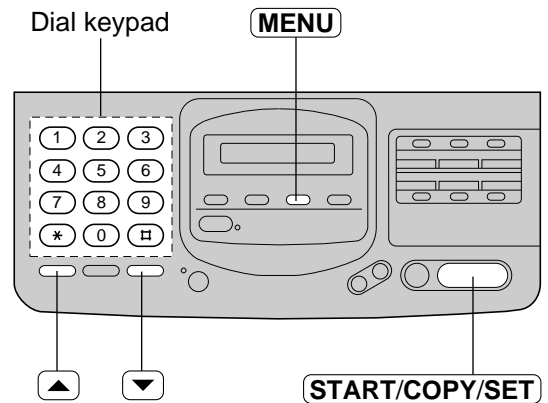
- 1 Press **MENU**.  

- 2 Press **⏏**, then **0 5**.  

- 3 Press **START/COPY/SET**.  

- 4 Press **▲** or **▼** to select the desired setting.
- 5 Press **START/COPY/SET**.
- 6 Press **MENU**.

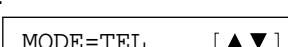

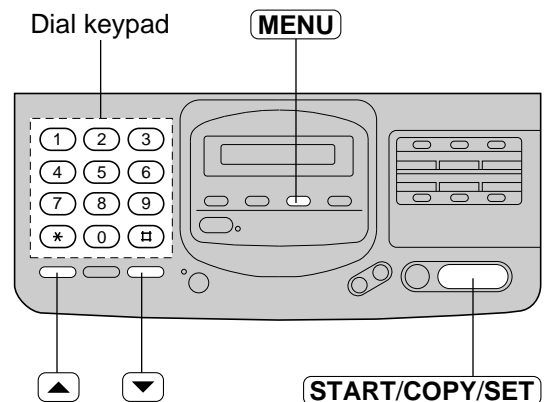
## Changing the setting of the MANUAL RECEIVE mode \_\_\_\_\_

You can select either TEL mode (pre-selected setting) or TEL/FAX mode in the MANUAL RECEIVE mode. If you want to change the setting, follow the steps below.

- 1 Press **MENU**.  

- 2 Press **⏏**, then **0 8**.  

- 3 Press **START/COPY/SET**.  

- 4 Press **▲** or **▼** to select the desired setting.
- 5 Press **START/COPY/SET**.
- 6 Press **MENU**.



# Adjusting volumes

## i Ringer volume

Press **VOLUME** ( / ·) while the unit is idle.

- 3 levels (high/low/off) are available.

### To turn the ringer off:

1. Press **VOLUME** ( ) repeatedly.

- The following message will be shown.

RINGER OFF= OK?

2. Press **START/COPY/SET**.

### While the ringer volume is set to off:

The display will show the following message and the unit will not ring when receiving a call.

RINGER OFF

## i Handset volume

Press **VOLUME** ( / ·) while using the handset.

- 3 levels (high/middle/low) are available.

## i Speaker volume

Press **VOLUME** ( / ·) while using the speakerphone.

- 8 levels (high to low) are available.

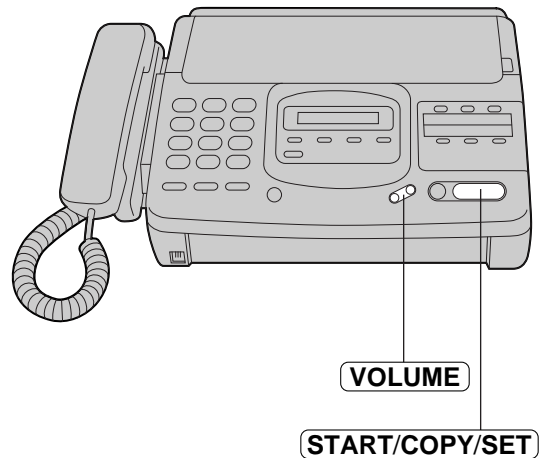



# Making voice calls

- 1 Press **SP-PHONE** or lift the handset.
- 2 Dial a phone number.
  - If you misdial, hang up and dial again.
- 3 When the other party answers, speak into the microphone or handset.
- 4 When finished, press **SP-PHONE** again or hang up the handset.

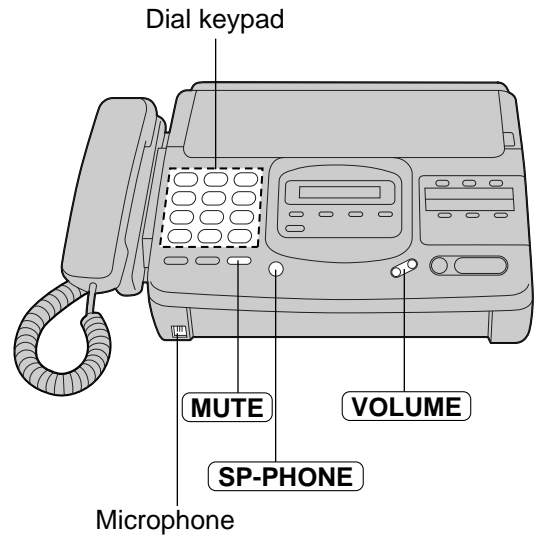

# Answering voice calls

- 1 When the unit rings, lift the handset or press **SP-PHONE**.
- 2 When finished, hang up the handset or press **SP-PHONE**.

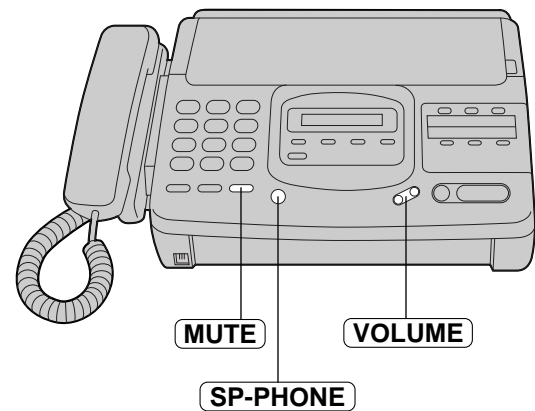

## Voice muting

Using this feature, the other party cannot hear you but you can hear them.

1. Press **MUTE** during a telephone conversation.

<MUTE>

2. To resume the conversation, press **MUTE** again.

## Hints for speakerphone operation

- Use the speakerphone in a quiet room.
- If the other party has difficulty hearing you, adjust the volume using **VOLUME**.
- If you and the other party speak at the same time, parts of your conversation will be lost.
- To switch to the handset, lift the handset. To switch back to the speakerphone again, press **SP-PHONE**.

# Transmitting documents

## Documents you can send

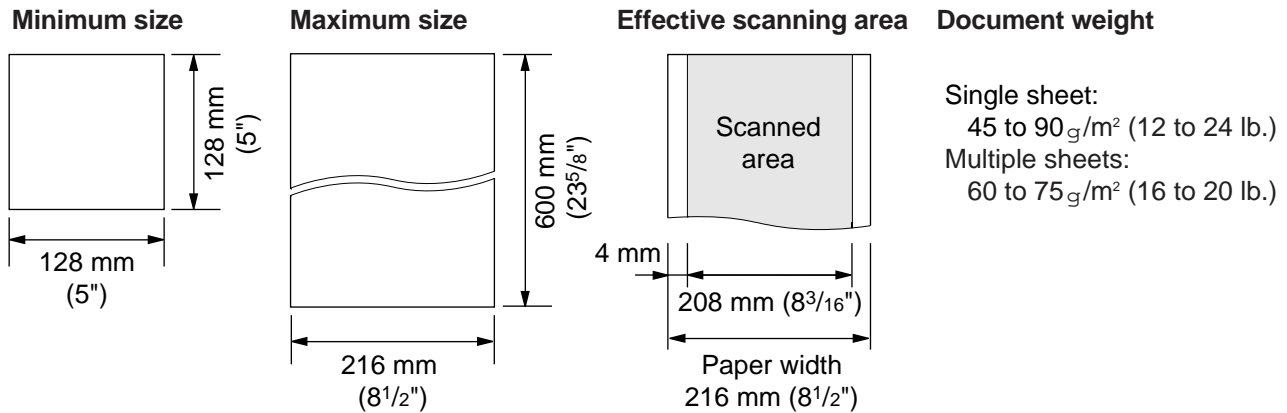

### Note:

- Remove clips, staples or other similar fastening objects.
- Check that ink, paste or correction fluid has dried.
- Do not send the following types of documents. Use copies for fax transmission.
  - Chemically treated paper such as carbon or carbonless duplicating paper
  - Electrostatically charged paper
  - Heavily curled, creased or torn paper
  - Paper with a coated surface
  - Paper with a faint image
  - Paper with printing on the opposite side that can be seen through the front (e.g. newspaper)

## Loading documents

- 1 Open the document feeder tray.
- 2 Insert the documents **FACE DOWN** until a beep tone is heard.
  - The unit can accept up to 15 sheets of paper at a time.
- 3 Adjust the document guides to the width of the document.
- 4 Press **RESOLUTION** repeatedly to the desired setting.

|            |                                                                    |
|------------|--------------------------------------------------------------------|
| STANDARD   | For printed or typewritten originals with normal-sized characters. |
| FINE       | For originals with small printing.                                 |
| SUPER FINE | For originals with minute printing.                                |
| HALF TONE  | For originals containing photographs, shaded drawings, etc.        |

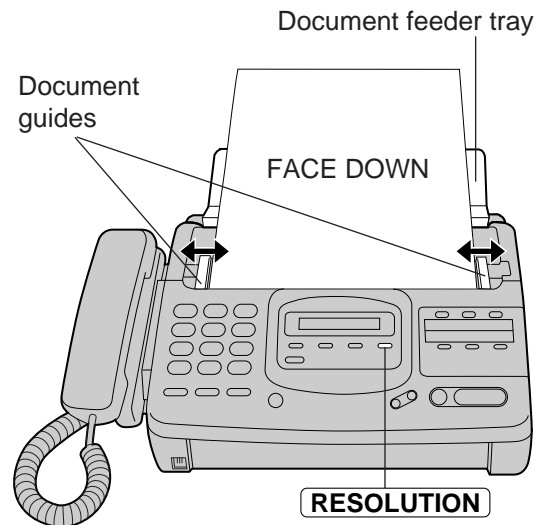

### Note:

- Using the fine, super fine or half tone setting will increase transmission time.
- If the resolution setting is changed during feeding, it will be effective from the next sheet.
- The super fine resolution only works with other compatible machines.

## Transmitting documents manually

- 1 Insert the documents **FACE DOWN** until a beep tone is heard.
- 2 Press **SP-PHONE** or lift the handset.
- 3 Dial a phone number.
  - If you misdial, hang up and dial again.
- 4 When a fax tone is heard, press **START/COPY/SET**.
- 5 Hang up the handset if using it.

### Note:

- If the other party answers your call, ask them to start receiving a fax, then press your **START/COPY/SET**.
- The unit will automatically end the transmission after the last sheet is transmitted.

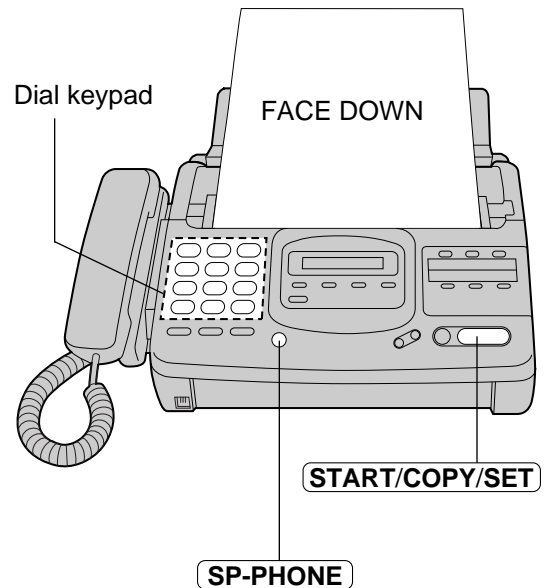

## Transmitting documents with fewer procedures

- 1 Insert the documents **FACE DOWN** until a beep tone is heard.
- 2 Dial a phone number.
  - If you misdial, press **STOP** and dial again.
- 3 Press **START/COPY/SET**.
  - The unit will start to dial and transmit the documents.

### Fax Auto Redial

- If there is no answer or the line is busy, the unit will automatically redial the number up to 5 times. This feature is available when you transmit documents with fewer procedures, automatic dialing (p. 27), delayed transmission (p. 32) and receive polling (p. 31). To cancel redialing, press **STOP**.

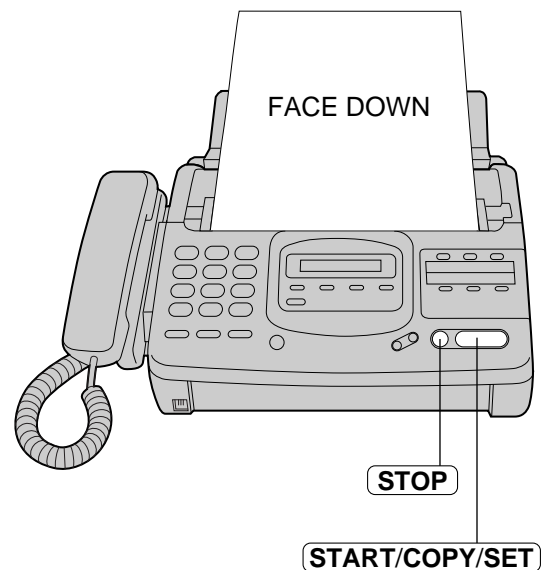

### To send 16 or more sheets at a time.

Insert the first 15 sheets of the document. Add the extra sheets (up to 15) before the last sheet is fed into the unit.

### To stop transmission

Press **STOP**.

- To eject the document, press **STOP** again.

# Receiving documents

---

## Receiving fax documents manually

---

- 1** When the unit rings, lift the handset or press **SP-PHONE** to answer the call.
- 2** When:
  - document reception is required,
  - a slow beep is heard, or
  - no sound is heard,press **START/COPY/SET**.
- 3** Hang up the handset if using it.
  - The recording paper will print out face side down.

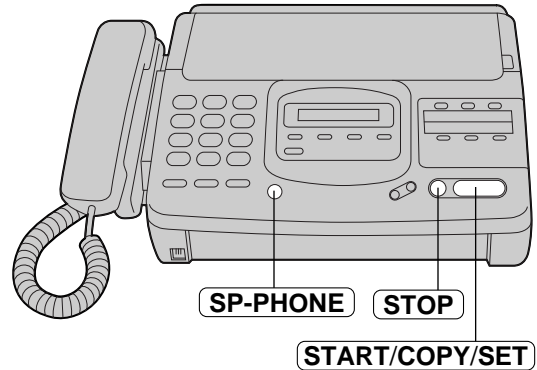

---

### Friendly reception

When you answer the call and hear a slow beep, the unit will automatically start reception even if you do not press **START/COPY/SET**.

- If this feature is not required, set to OFF (see page 43).

### To stop reception

Press **STOP**.

# Receiving fax documents only (FAX mode)

When you turn on the AUTO RECEIVE mode that is set to FAX, the unit will work as a dedicated facsimile machine.

The unit will automatically answer all calls and generate fax tones to the callers.

Callers will hear fax tones and will only be able to transmit faxes.

## Setting up the unit for fax reception

- 1 Set the AUTO RECEIVE mode to FAX (see page 15).
- 2 Turn on the AUTO RECEIVE mode by pressing **AUTO RECEIVE** until the FAX indicator light goes on.
  - The display shows the following message.

FAX MODE

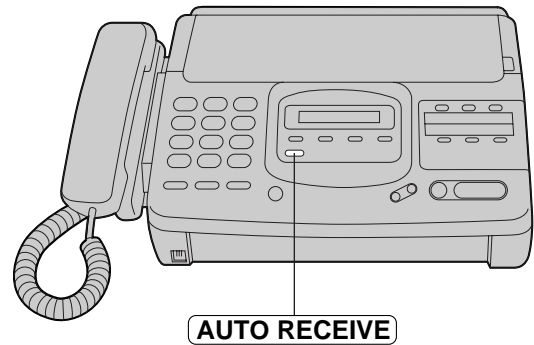

## Setting the FAX mode ring count

This feature determines the number of rings after which the unit answers a call in the FAX mode. You can choose from 1 to 4 rings.

### Helpful hints:

- To answer a call before the unit does, increase the number of rings.
- If you find receiving faxes from machines with an automatic transmission feature difficult, decrease the number of rings.

- 1 Press **MENU**.  
SYSTEM SET UP
- 2 Press **☐**, then **0 7**.  
FAX RING
- 3 Press **START/COPY/SET**.  
RING=1 [▲▼]
- 4 Press **▲** or **▼** to select the desired number.
- 5 Press **START/COPY/SET**.
- 6 Press **MENU**.

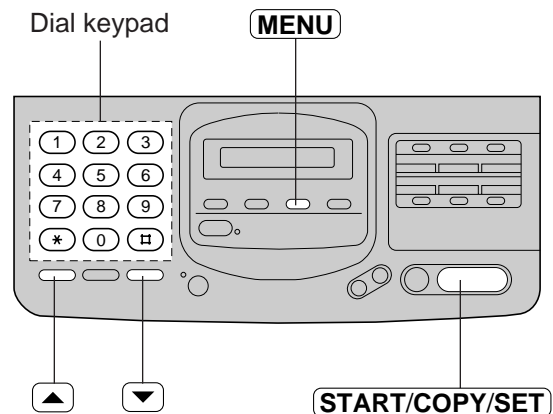

### Note:

- If an extension telephone with a caller ID or call display feature is connected to the same line, set the number of rings to more than 2.

## Receiving both voice and fax calls (TEL/FAX mode) \_\_\_\_\_

Use this mode when you wish to receive voice calls with ring but do not want to hear the unit ring when faxes are received.

When a call is received, the unit will work as follows.

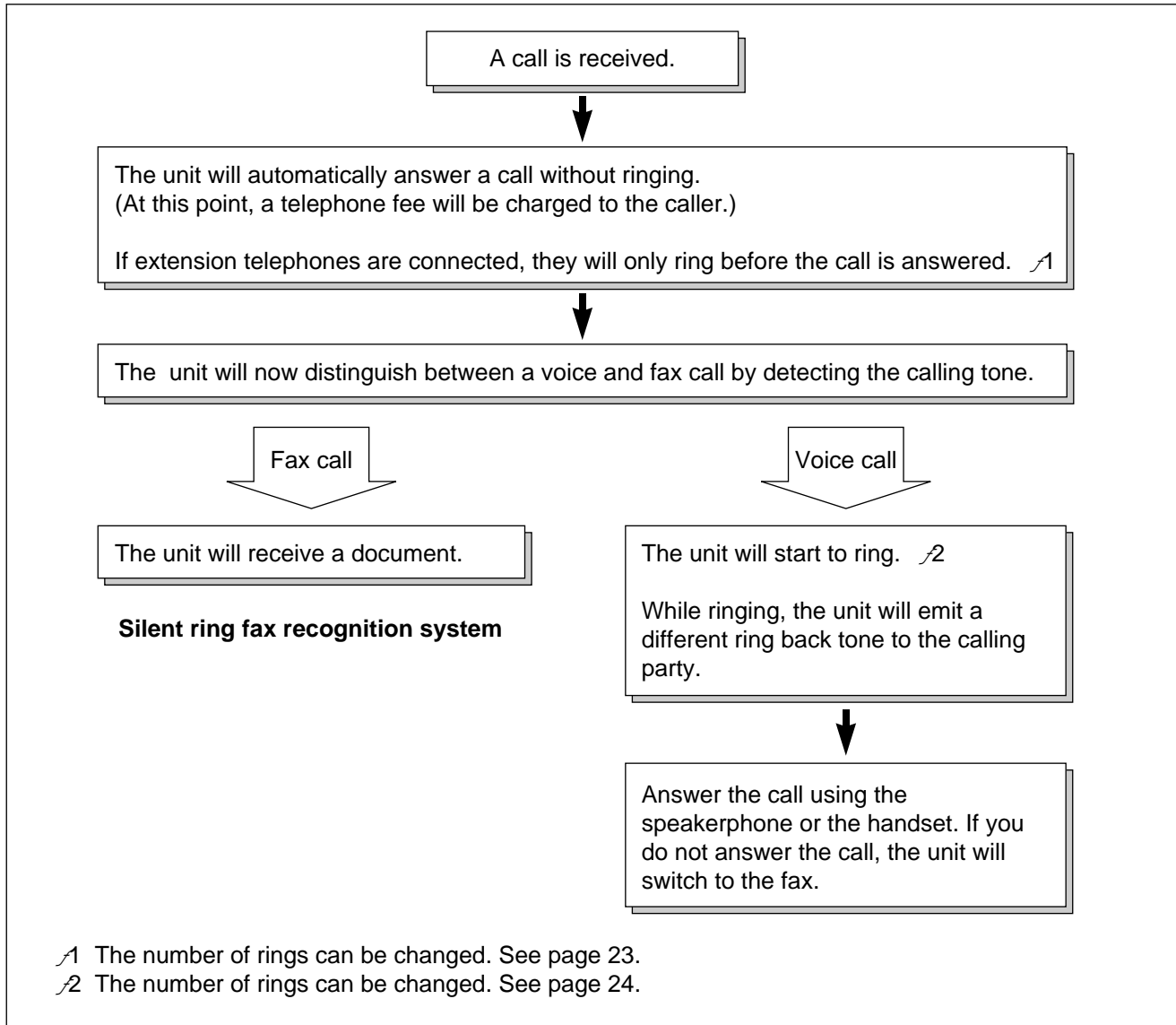

### Note:

- Some fax messages that are transmitted manually may not send a calling tone. These calls must be manually received.

## Setting up the unit

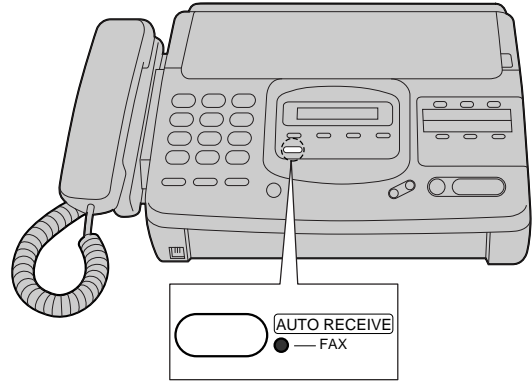

- 1 Set the MANUAL RECEIVE mode to TEL/FAX (see page 15).
- 2 Make sure that the AUTO RECEIVE mode is turned off.
  - If the FAX indicator light is on, press **AUTO RECEIVE** to turn off the AUTO RECEIVE mode.



## Setting the TEL/FAX mode ring count

This feature determines the number of rings after which the unit automatically answers a call in the TEL/FAX mode.

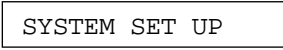
You can choose from 1 to 4 rings.

- 1 Press **MENU**.  

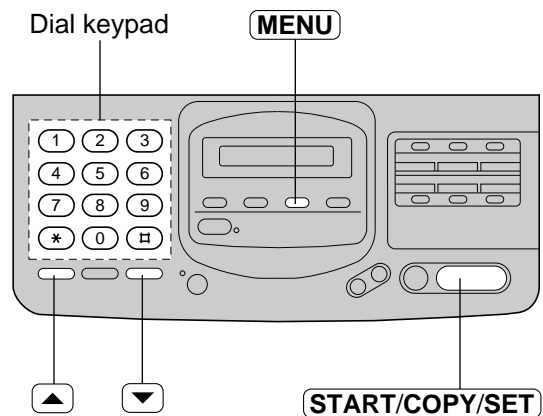
- 2 Press **⏏**, then **0 9**.  

- 3 Press **START/COPY/SET**.  

- 4 Press **▲** or **▼** to select the desired number.
- 5 Press **START/COPY/SET**.
- 6 Press **MENU**.



### Note:

- If an extension telephone with a caller ID or call display feature is connected to the same line, set the number of rings to more than 2.

## Setting the silent fax recognition ring count

When a fax call is received in the TEL/FAX mode, the unit will automatically activate the fax function without ringing. If the unit detects a voice call, it will ring. You can choose from 3 to 6 rings.

- 1 Press **MENU**.
  - 2 Press **#**, then **3** **0**.
  - 3 Press **START/COPY/SET**.
  - 4 Press **▲** or **▼** to select the desired setting.
  - 5 Press **START/COPY/SET**.
  - 6 Press **MENU**.
- SYSTEM SET UP
- SILENT FAX RING
- RING=3 [▲▼]

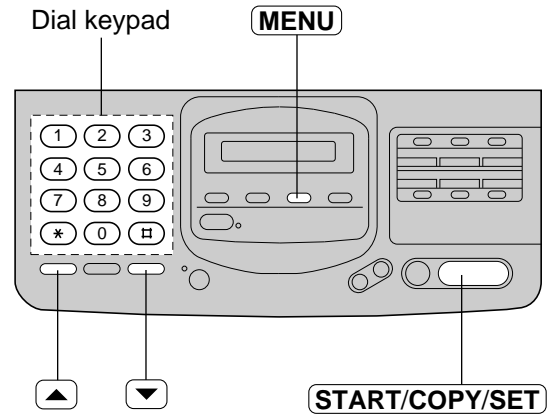



# Making a copy

---

---

Any transmittable document can be copied (see page 18).

**1** Insert the documents (up to 15 sheets) FACE DOWN until a beep tone is heard.

**2** Press **START/COPY/SET**.

**Note:**

- When copying, the unit will automatically select FINE resolution. To change the resolution, press **RESOLUTION**.
- You can make or receive a voice call while making a copy.

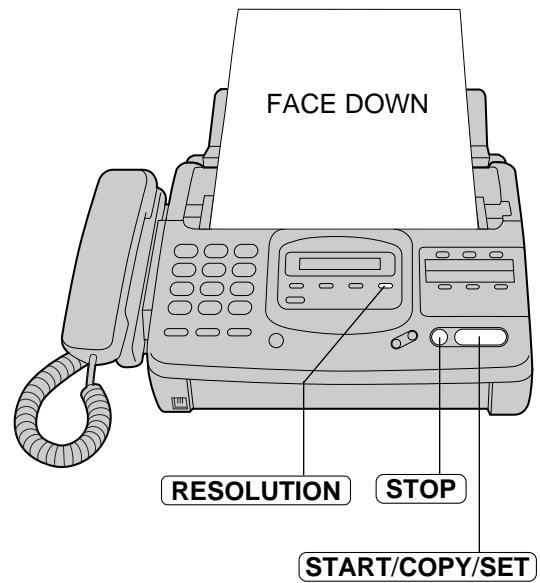

---

## To stop copying

Press **STOP**.

# Storing phone numbers for automatic dialing

The unit's memory allows you to use both one-touch dialing and speed dialing for rapid access to your most frequently dialed numbers.

**One-touch dialing:** The unit is equipped with 5 direct call station keys, each of which is divided into an upper station and a lower station.

**Speed dialing:** The unit is equipped with 50 additional dialing stations. These stations are assigned to 2-digit numbers (00–49).

- 1** Press **MENU** until the following message is displayed.

STORE TEL NO.

- 2 a: Programming for one-touch dialing:**  
**For upper stations (1–5)**  
Press one of the direct call station keys.

**For lower stations (6–10)**

Press **LOWER**, then press one of the direct call station keys.

**b: Programming for speed dialing:**

Press **\***, then press the desired 2-digit number (00–49).

- 3** Enter the phone number up to 30 digits in length.  
• To enter a hyphen in a phone number, press **LOWER**.

- 4** Press **START/COPY/SET**.

NAME=

- 5** Enter the station name, up to 10 characters, by following the instructions on page 13.

- 6** Press **START/COPY/SET**.  
• To program other stations, repeat steps 2 to 6.

- 7** Press **STOP**.

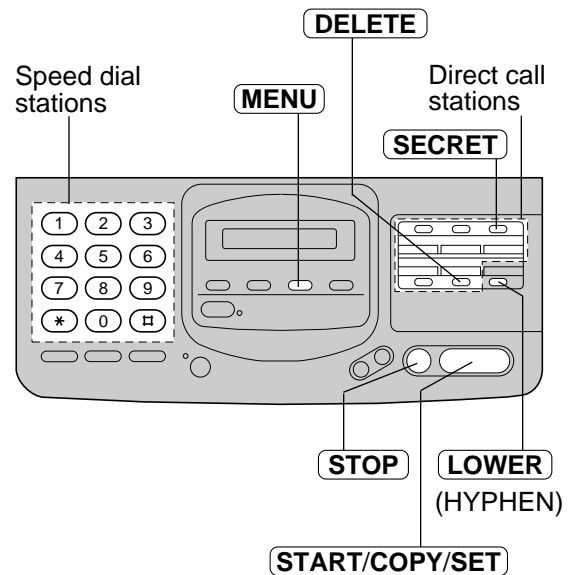

**Helpful hint:**

- To confirm stored phone numbers and station names, print a telephone number list (see page 46).

## To keep whole or part of the phone number secret

Press **SECRET** (direct call station 3) before and after the number you wish to keep secret.

- The phone number will not appear on the display and on the telephone number list.
- Pressing **SECRET** once counts as two digits.

## To erase a stored number and station name

Press **STOP** in step 3 to clear the phone number. Press **DELETE** (direct call station 5) repeatedly in step 5 until all of the characters are erased. Then, press **START/COPY/SET**.

# Making voice calls using automatic dialing

- 1 Press **SP-PHONE** or lift the handset.
- 2 **a: Using one-touch dialing:**  
**For upper stations (1–5)**  
Press the desired direct call station key.  
**For lower stations (6–10)**  
Press **LOWER**, then press the desired direct call station key.  
**b: Using speed dialing:**  
Press **DIRECTORY**, then press **#** and the desired 2-digit number (00–49).

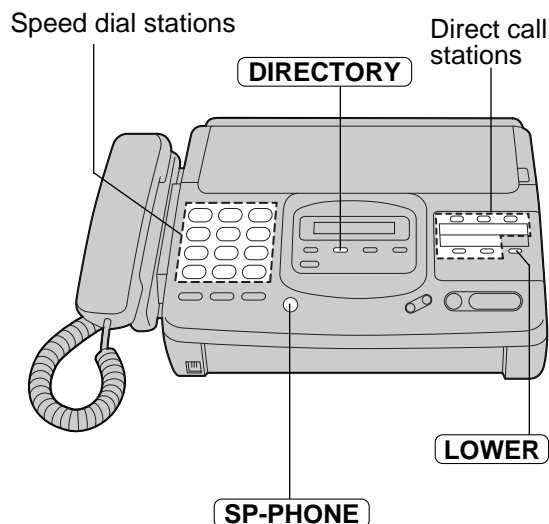

# Transmitting documents using automatic dialing

- 1 Insert the documents FACE DOWN.
- 2 **a: Using one-touch dialing:**  
**For upper stations (1–5)**  
Press the desired direct call station key.  
**For lower stations (6–10)**  
Press **LOWER**, then press the desired direct call station key.  
**b: Using speed dialing:**  
Press **DIRECTORY**, then press **#** and the desired 2-digit number (00–49).

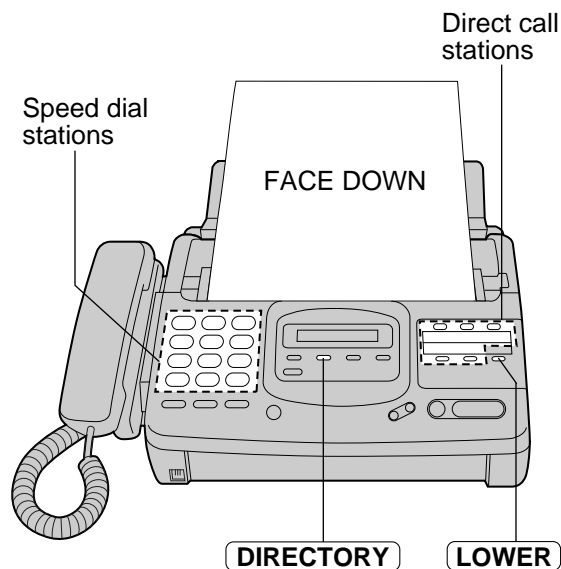

# Electronic telephone directory

The station names stored in memory are automatically registered into the electronic telephone directory in alphabetical order. You can make a fax or voice call by selecting the desired station name on the display.

If you wish to send a fax, insert the documents into the document tray first.

**1** Press **DIRECTORY**. SELECT INDEX

**2** Press the dial key in which the first initial of the station name is assigned (see index table below).

**Example:** To search a name with the initial "N":  
 Press **6** repeatedly until the first station name with initial "N" is displayed. Press **▼** until the desired name is displayed.

OR

Press **▲** or **▼** repeatedly until the desired name is displayed.

**3** Press **START/COPY/SET**.

- The unit will start dialing.
- If a document is fed into the unit, the unit will start transmission.

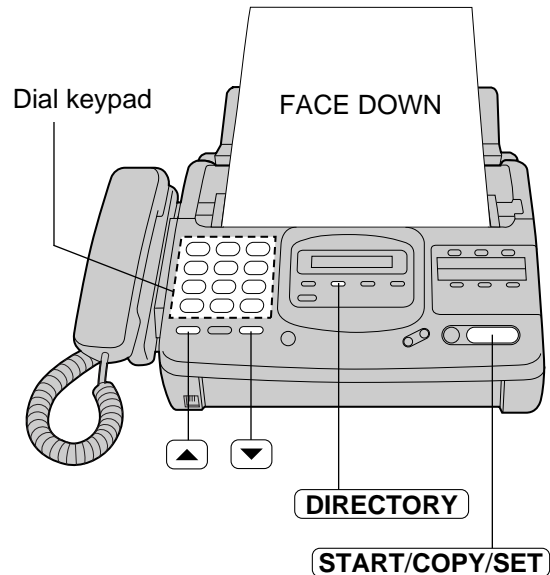

| Dial key | Index      | Dial key | Index                    |
|----------|------------|----------|--------------------------|
| 1        | 1          | 7        | P, Q, R, S, 7            |
| 2        | A, B, C, 2 | 8        | T, U, V, 8               |
| 3        | D, E, F, 3 | 9        | W, X, Y, Z, 9            |
| 4        | G, H, I, 4 | 0        | 0                        |
| 5        | J, K, L, 5 | *        | Other symbols            |
| 6        | M, N, O, 6 | #        | (Used for speed dialing) |

# Voice contact

## (talking to the caller during or after fax reception or transmission)

You can have a conversation with the same call after the fax message is completed. This will save the extra expense and time of making another call.

**This feature works only when the other party's unit is equipped with a voice contact feature.**

## Initiating voice contact

**1** Press **SP-PHONE** while transmitting or receiving documents.

VOICE STANDBY

- Your unit will call the other party with a distinctive ring.

**2** When the other party answers, the unit will emit a distinctive ring.

Press **SP-PHONE** or lift the handset to start talking.

- If you initiate voice contact during transmission, you can talk after all the documents have been transmitted.
- If you initiate voice contact during reception, you can talk after the current page of the document is received.

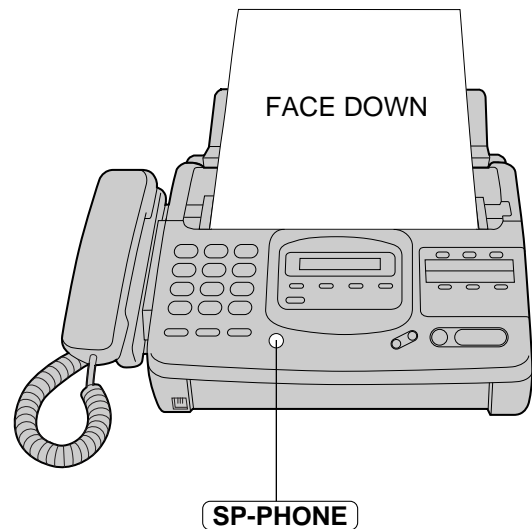

## Receiving a request for voice contact

If the other party initiates voice contact, your unit will emit a distinctive ring after transmission or reception is completed.

When the distinctive ring is heard, press **SP-PHONE** or lift the handset, then start speaking.

**Note:**

- If you do not answer within 10 seconds of hearing the distinctive ring, the line will be automatically disconnected.

# TONE, FLASH and REDIAL/PAUSE buttons

## TONE button

The TONE (\*) button is used for rotary pulse dial services and allows you to temporarily change from pulse to tone mode during a dialing operation. When you hang up, the unit will automatically return to pulse mode.

## FLASH button

The FLASH button functions as the hookswitch on a regular phone. If you misdial or dial another phone number, press the FLASH button firmly.

The FLASH button also allows you to use special features of a host exchange (if connected) or local telephone company services such as call waiting. For further details, contact your local telephone company.

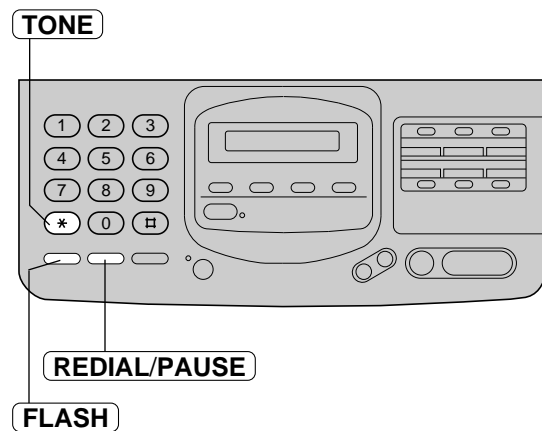

### Note:

- TONE, FLASH and PAUSE can be stored into a phone number for automatic dialing.

## Entering pauses

If the REDIAL/PAUSE button is pressed during dialing, a pause will be inserted.

**Example-1:** When your unit is connected to a host exchange, insert a pause to get an outside line.

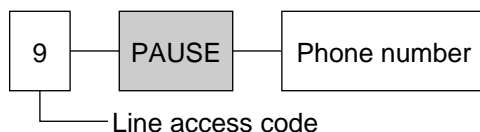

**Example-2:** If transmission errors occur when making an overseas transmission, add two pauses at the end of the phone number.

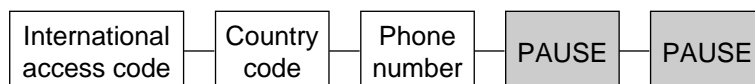

## Redialing the last number dialed

If the REDIAL/PAUSE button is pressed immediately after a dial tone is obtained, the last number dialed will be redialed.

1. Lift the handset or press **SP-PHONE**.
2. Press **REDIAL/PAUSE**.
  - If the line is busy when using the speakerphone, the unit will automatically redial the number up to 14 times.

# Polling

---

## (retrieving fax documents)

The polling feature allows you to receive a document from another compatible machine where you pay for the call as opposed to the document being sent to you, thereby saving the other party call charges.

## Receiving polling

---

To place a call and recover a document from another machine, follow the steps below. Make sure that no documents have been fed into your unit and that the other party's machine is ready for your call.

- 1 Press **MENU** until the following is displayed.  

POLLING
- 2 Press **START/COPY/SET**.  

NO. =
- 3 Enter the phone number by using one-touch dialing, speed dialing, full number dialing or the electronic telephone directory (see page 28).
- 4 Press **START/COPY/SET**.

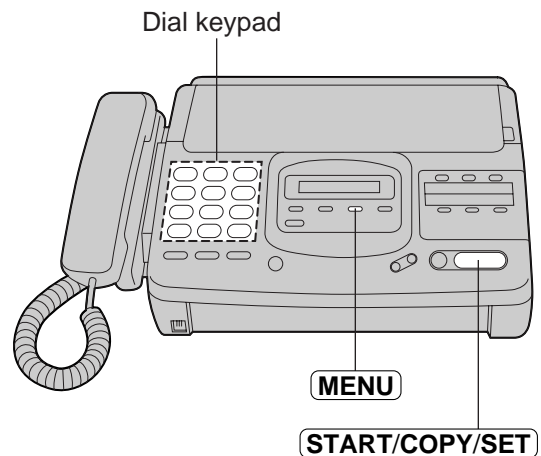

## Transmit polling

---

A document stored in your unit can be recovered by another party's machine. To let other machines retrieve documents loaded on your unit, proceed as follows.

- 1 Insert the documents FACE DOWN.
- 2 Press **MENU** until the following is displayed.  

POLLED
- 3 Press **START/COPY/SET**.  

MODE=OFF [▲▼]
- 4 Press ▲ or ▼ to select "ON".  

MODE=ON [▲▼]

  - If this feature is not required, select "OFF".
- 5 Press **START/COPY/SET**.  

POLLED ON

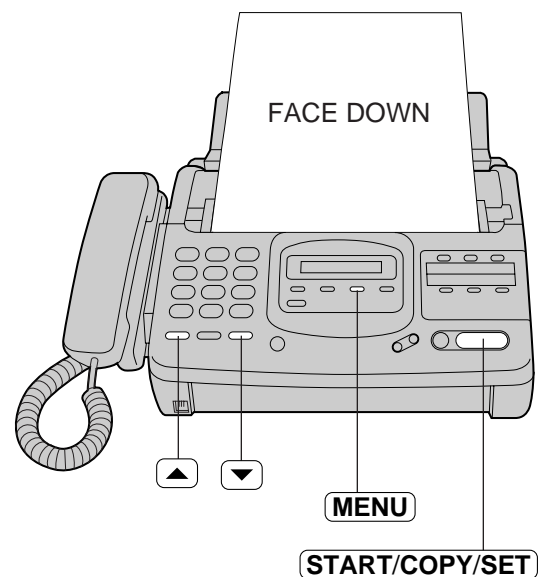

### Note:

- When delayed transmission (page 32) is set to ON, transmit polling is not available.

# Delayed transmission

## (sending a fax at a later time)

Using a built-in clock, this unit can send documents automatically at a specific time. This allows you to take advantage of low-cost calling hours offered by your telephone company. The delayed transmission can be reserved to take place up to 24 hours.

- 1 Insert the documents FACE DOWN.
- 2 Press **MENU**.  

SYSTEM SET UP
- 3 Press **☐**, then press **2** **5**.  

DELAYED XMT
- 4 Press **START/COPY/SET**.  

MODE=OFF [▲▼]
- 5 Press **▲** or **▼** to select "ON".  

MODE=ON [▲▼]

  - If this feature is not required, select "OFF".
- 6 Press **START/COPY/SET**.  

NO. =
- 7 Enter the phone number by using one-touch dialing, speed dialing, full number dialing or the electronic telephone directory.
- 8 Press **START/COPY/SET**.  

TIME=12:00AM
- 9 Enter the transmission start time.  
**Example:** 11:00 PM  
 Press **1** **1** **0** **0**, then press **☐** to select PM.  
 To select AM, press **\***.
- 10 Press **START/COPY/SET**.
- 11 Press **MENU**.  
  - When the programmed time has come, the unit will automatically start transmission.

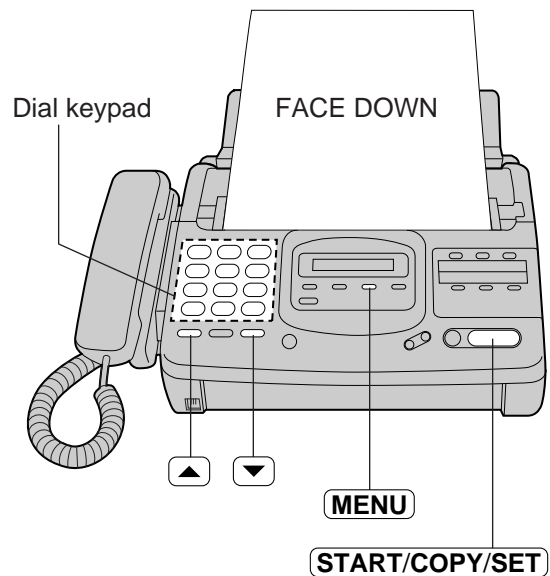

### Note:

- You can receive, transmit and copy documents while delayed transmission is set.
- When transmit polling (see page 31) is ON, delayed transmission is not available.



# Sending documents overseas

You may experience difficulty in transmitting documents overseas. This feature will make sending documents easier as the transmission speed is slowed down. Before starting the transmission procedure, follow the steps below.

**1** Press **MENU**.  
SYSTEM SET UP

**2** Press **⏏**, then **2** **3**.  
OVERSEAS MODE

**3** Press **START/COPY/SET**.  
MODE=OFF [▲▼]

**4** Press **▲** or **▼** to select "ON".  
MODE=ON [▲▼]

• If this feature is not required, select "OFF".

**5** Press **START/COPY/SET**.

**6** Press **MENU**.

## Note:

• After transmission, this feature will be turned off automatically.

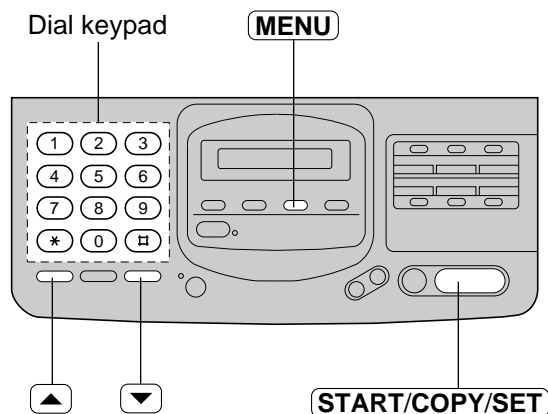

# Remote fax receiving

## (using an extension to receive a fax message)

If you have an extension phone connected to your facsimile unit or on the same line, it is possible to receive a fax message. Using the extension phone, dial the remote fax activation code. This saves you from going to the facsimile unit and pressing **START/COPY/SET**.

### Important:

- To activate this feature, use a touch tone telephone as the extension phone and enter the remote fax activation code **FIRMLY**.
- The remote activation code is set to “\* \*” as a pre-selected setting.

## Receiving using an extension

- 1 When a call is received, lift the handset of the extension phone.
- 2 When:
  - document reception is required,
  - a slow beep is heard, or
  - no sound is heard,enter the remote fax activation code **FIRMLY**.
- 3 Hang up the handset.
  - The facsimile unit is activated for reception.

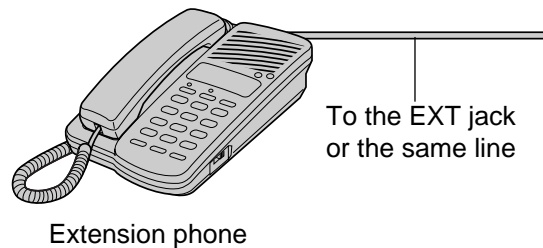

## Changing the remote fax activation code

This code can be from 2 to 4 digits in length using numbers 0 through 9 and the character \* .

- 1 Press **MENU**.  
SYSTEM SET UP
- 2 Press **☐**, then **4 1**.  
REMOTE FAX ACT.
- 3 Press **START/COPY/SET**.  
MODE=ON [▲▼]
- 4 Press **▲** or **▼** to select the desired setting.
  - If this feature is not required, select “OFF” .
- 5 Press **START/COPY/SET**.  
CODE=\*\*
- 6 Enter the new code number.
- 7 Press **START/COPY/SET**.
- 8 Press **MENU**.

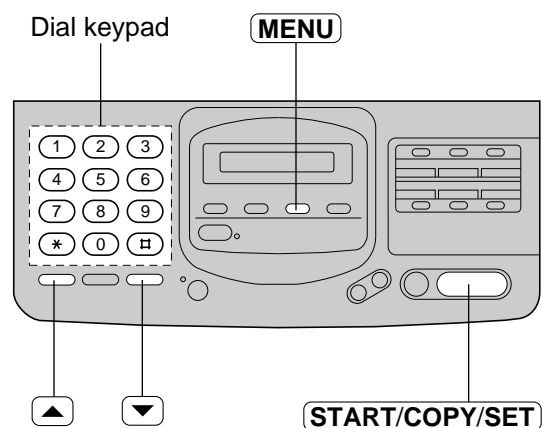

### Note:

- Some special telephone company services will require you to press a service access code. If you subscribe to such services, whole or part of the remote fax activation code must be different from the service access code.
- If the remote fax activation code is set to “0000”, the unit does not work properly.

# Junk mail prohibitor

## (preventing the reception of unwanted fax documents)

This feature prevents reception from facsimile machines whose phone numbers are not stored in automatic dialing.

### Important:

- This feature does not work when:
  - the unit is set to the TEL mode,
  - manual reception is performed, or
  - the other party does not program their facsimile telephone number correctly.
- The junk mail prohibitor ID must be different from the first 2 digits of the remote TAM activation ID (page 40). e.g. if the remote TAM activation ID is “321”, do not use “32” as a junk mail prohibitor ID.

## Setting the junk mail prohibitor and ID

- 1 Press **MENU**.  
SYSTEM SET UP
- 2 Press **#**, then **2** **4**.  
JUNK MAIL PROH.
- 3 Press **START/COPY/SET**.  
MODE=OFF [▲▼]
- 4 Press **▲** or **▼** to select “ON”.  
MODE=ON [▲▼]
  - If this feature is not required, select “OFF”.
- 5 Press **START/COPY/SET**.  
ID=22
- 6 To change the junk mail prohibitor ID, enter the desired 2-digit number.
  - 0, #, and \* cannot be used.
- 7 Press **START/COPY/SET**.
- 8 Press **MENU**.

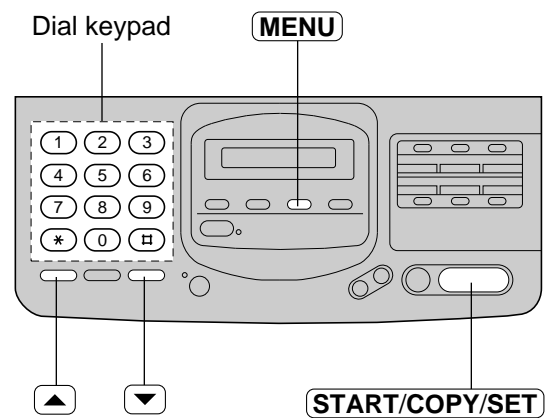

## Transmitting documents to your unit with the prohibitor ID

Even if the junk mail prohibitor feature is activated, a designated caller will be able to transmit documents. Give your junk mail prohibitor ID to your designated callers, and advise them of the following steps. This operation is available in the AUTO RECEIVE mode (EXT.TAM only) or the MANUAL RECEIVE mode (TEL/FAX only).

1. Call your unit from a touch tone telephone.
2. Dial the prohibitor ID while the greeting message is playing or a different ring back tone is heard.
3. Listen for a fax tone, and start transmission.

# Receiving with distinctive ring service

This feature can only be used by those who subscribe to a distinctive ring pattern service from their telephone company. For more information on the availability of this service, please contact your telephone company before setting this feature to ON.

The distinctive ring service gives you up to 3 phone numbers on a single telephone line, each having a different ringing pattern.

When you use one of the phone numbers as a facsimile number, program the ringing pattern assigned for fax into your unit. When the unit detects a call matching the selected distinctive ringing pattern, the unit will activate depending on the receive mode setting.

## Setting the distinctive ringing pattern

Program the ring pattern assigned for fax. Ringing patterns that can be programmed are;

- A: Standard ring (One long ring)
- B: Double ring (Two short rings)
- C: Triple ring (Short-long-short rings)
- D: Other triple ring (Short-short-long rings)
- OFF: Turns off the ring pattern detection feature (pre-selected setting)

1 Press **MENU**.

SYSTEM SET UP

2 Press **Ⓜ**, then **3 1**.

RING DETECTION

3 Press **START/COPY/SET**.

MODE=OFF [▲▼]

4 Press **▲** or **▼** to select the desired mode.

5 Press **START/COPY/SET**.

6 Press **MENU**.

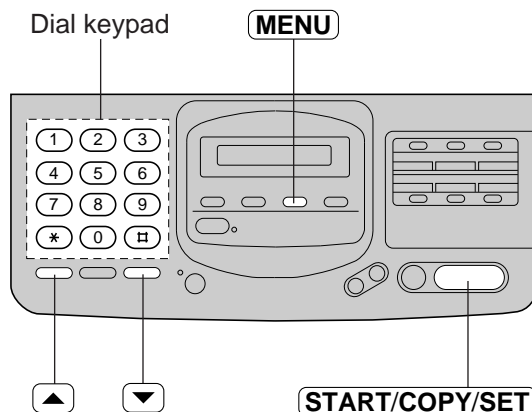

## How the unit will answer in each receive mode

- ; **EXT.TAM mode:** When a distinctive ringing pattern that matches your selection is detected, the unit will automatically answer the line and activate the fax function to receive documents. If other ringing patterns are received, the facsimile unit and the answering machine will activate depending on the call.
- ; **TEL/FAX mode:** When a distinctive ringing pattern that matches your selection is detected, the unit will automatically answer the line and activate the fax function to receive documents. If other ringing patterns are received, the unit will ring until you pick up.
- ; **TEL mode:** In this mode, you have to answer all calls manually.
- ; **FAX mode:** In this mode, the unit will answer all calls and activate the fax function.

### Note:

- The unit automatically answers a distinctive ring call after the second ring. To change the number of rings, change the FAX mode ring count (page 21) after setting the ringing pattern.

# Signaling your pager that you have received a fax document

This feature allows your unit to call your pager when your unit receives a fax message.

**1** Press **MENU**.

SYSTEM SET UP

**2** Press **#**, then **7 0**.

FAX PAGER

**3** Press **START/COPY/SET**.

MODE=OFF [▲▼]

**4** Press **▲** or **▼** to select "ON".

MODE=ON [▲▼]

• If this feature is not required, select "OFF".

**5** Press **START/COPY/SET**.

NO. =

**6** Enter your pager phone number.  
If necessary, press **REDIAL/PAUSE** twice.  
Contact your pager company regarding the proper pause time.

If your pager has the ability to display phone numbers, enter the number that you wish to appear on the display.

Press **#** if required by your pager company.

• You may enter a total of 46 digits and/or pauses.

**7** Press **START/COPY/SET**.

**8** Press **MENU**.

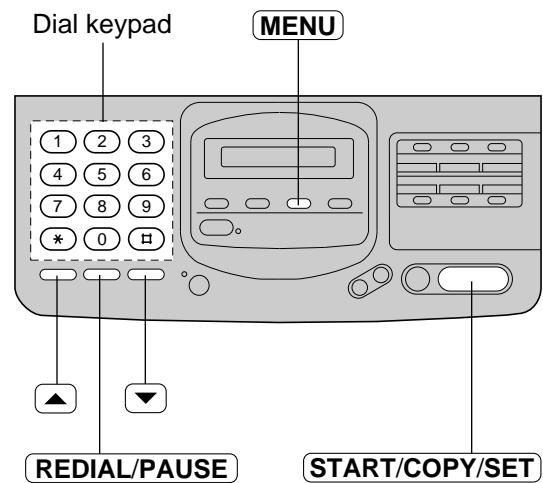

# Using an external telephone answering machine

---

This unit can be connected to an external telephone answering machine (TAM). When the EXT. TAM mode is selected, incoming voice messages will be recorded on the telephone answering machine and fax messages will be received by the facsimile unit.

## Setting up the answering machine

---

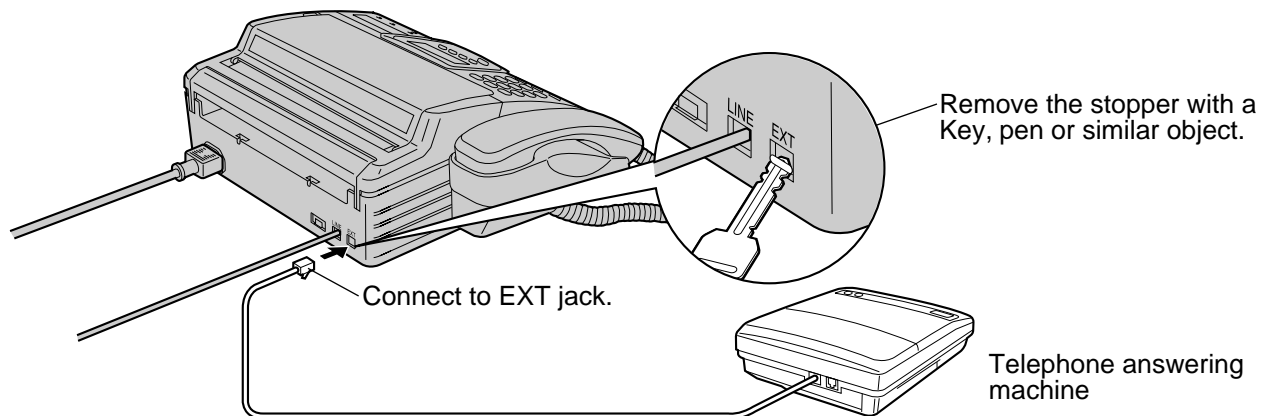

1. Connect the telephone answering machine to the EXT jack.
2. Set the number of rings on the telephone answering machine to less than 4.
3. Record a greeting message referring to the example below.  
*"This is (your name, business and/or telephone number). We are unable to answer the phone right now. Please leave a message after the long beep. To send a fax, dial my remote fax activation code and start transmission. Thank you."*

### Notice for recording a greeting message:

- Do not pause for more than 4 seconds in the message.
- Your message can be 8 to 16 seconds long. We recommend you to keep it around 10 seconds in length.
- Inform the fax caller of your remote fax activation code beforehand (see page 34).

## Setting the EXT.TAM mode

---

To set the facsimile unit and telephone answering machine to allow callers to leave a voice message and send a fax message, proceed as follows.

- 1 Turn on the answering machine.
- 2 Set the AUTO RECEIVE mode to EXT.TAM (see page 15).
- 3 Turn on the AUTO RECEIVE mode by pressing **AUTO RECEIVE** until the FAX indicator light goes on.
  - The display shows the following message.

EXT.TAM MODE

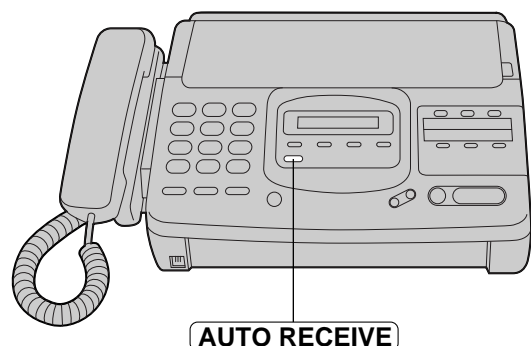

# How to receive incoming calls in the EXT.TAM mode \_\_\_\_\_

When a call is received, the facsimile unit and external telephone answering machine will work as follows.

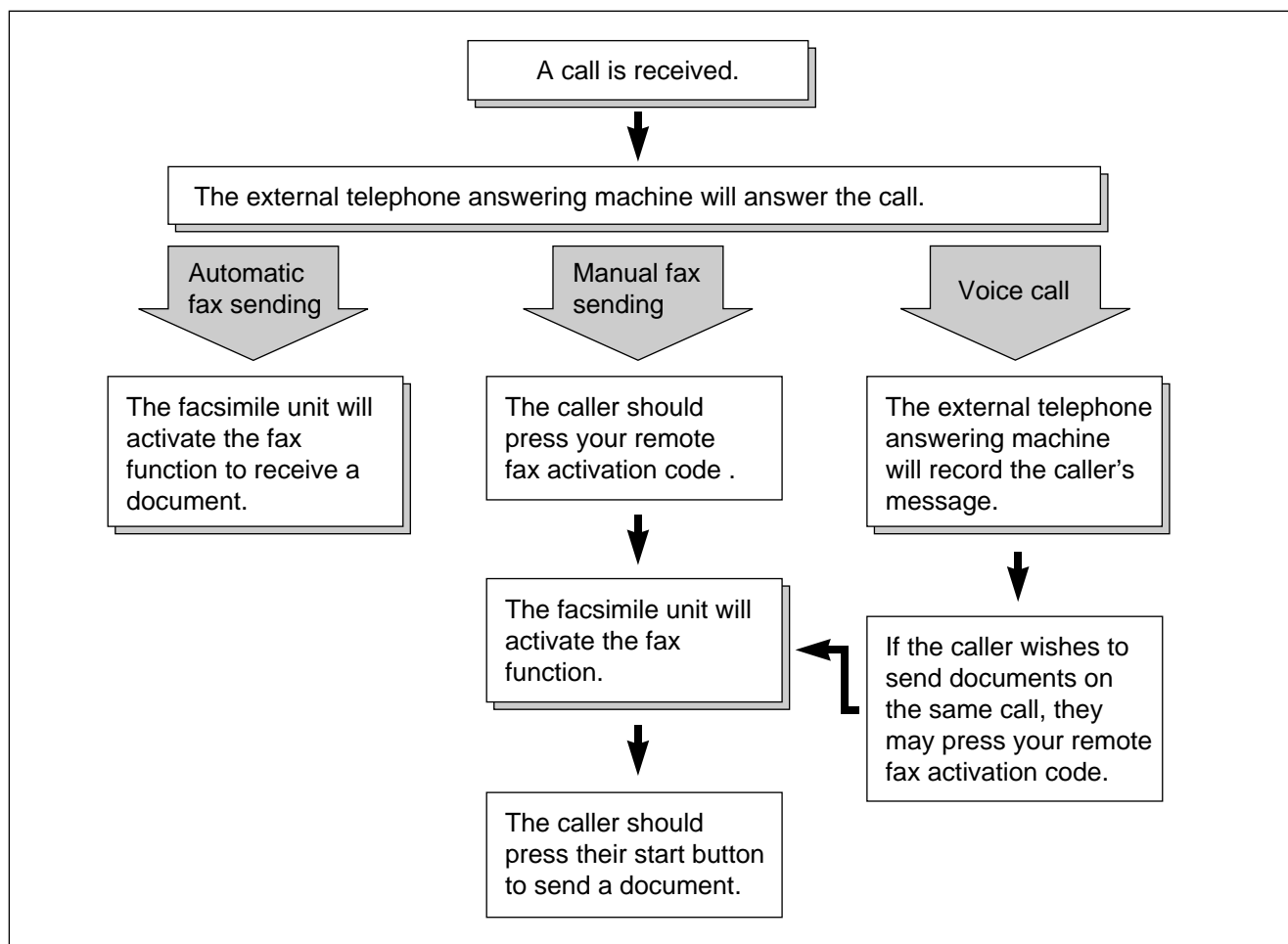



# Setting the remote TAM activation ID \_\_\_\_\_

If your answering machine is equipped with a remote operation feature, set the same access code on the facsimile unit as programmed on the answering machine. This feature prevents the facsimile unit from activating the fax function when you operate the answering machine from a remote location. This code can be from 1 to 5 digits in length.

**Important:**

- This code should be different from the remote fax activation code (see page 34) and the junk mail prohibitor ID (see page 35).

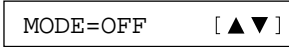
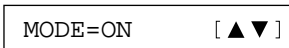
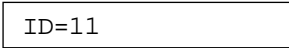
- 1 Press **MENU**.  

- 2 Press **□**, then **1** **2**.  

- 3 Press **START/COPY/SET**.  

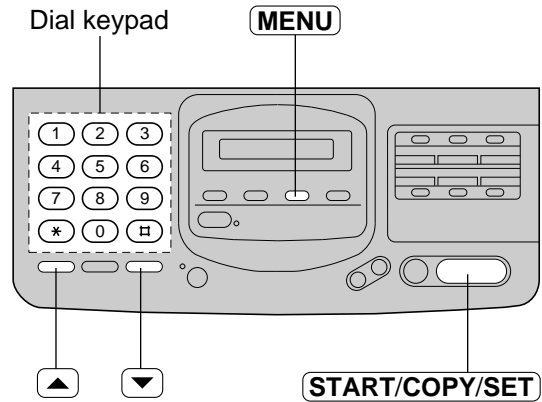
- 4 Press **▲** or **▼** to "ON".  

- 5 Press **START/COPY/SET**.  

- The display will show the pre-selected ID.

- 6 Enter the new ID number using the dial keypad.
- 7 Press **START/COPY/SET**.
- 8 Press **MENU**.





# Setting the silent detection

This feature allows the facsimile unit to activate the fax function automatically when a silent pause longer than 4 seconds is detected in the EXT. TAM mode.

## Helpful hints:

- If you wish to receive documents from stations that do not send a calling tone after dialing, activate this feature.
- If you use a single cassette tape to give a greeting message and to record incoming messages, deactivate this feature.

- 1 Press **MENU**.  
SYSTEM SET UP
- 2 Press **☐**, then **4 0**.  
SILENT DETECT.
- 3 Press **START/COPY/SET**.  
MODE=ON [▲▼]
- 4 Press **▲** or **▼** to select the desired mode.
- 5 Press **START/COPY/SET**.
- 6 Press **MENU**.

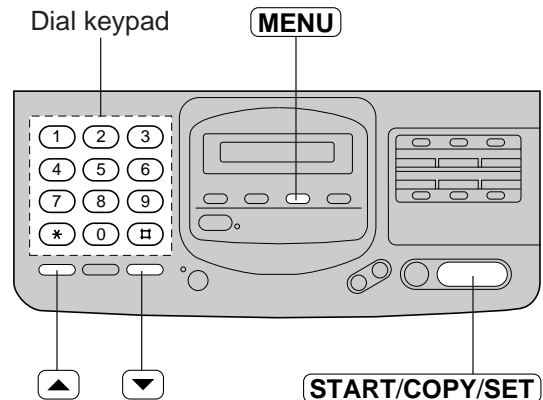

## Notice when using with an answering machine

- Every time the facsimile unit receives a document, a silent pause or a fax tone may be recorded on the answering machine.
- Advise callers that they should not pause for over 4 seconds while recording their voice messages. Otherwise, the unit may switch to the fax mode.
- When your answering machine runs out of recording tape, the unit may not be able to receive a document. Rewind the tape to record messages.
- When you set the answering machine to give only a greeting message, fax reception may not be available.
- If you answer a call with the answering machine and pause for over 4 seconds, the unit may switch to the fax mode and you may not be able to talk with the other party. To resume the conversation, press **STOP** on the facsimile unit.
- When the answering machine does not answer a call after 5 rings, the fax function will be activated.
- Set the receive mode of the facsimile unit to the TEL mode under the following conditions:
  - when you wish to set the number of rings on the answering machine to more than 5, or
  - when you wish to use the auto transfer functions (transfer, pager alert, etc.) on the answering machine.Note that automatic fax sending can not be received automatically in the TEL mode.

# Changing the logo print position

The logo, telephone number, date, time and page number will be printed on the transmitted document from your unit in the following manner.

**OUT:** Outside of the transmitted document's paper size (pre-selected setting).

**IN:** Inside of the transmitted document's paper size.

- 1 Press **MENU**.  
SYSTEM SET UP
- 2 Press **⏏**, then **2** **1**.  
LOGO POSITION
- 3 Press **START/COPY/SET**.  
MODE=OUT [▲▼]
- 4 Press **▲** or **▼** to select the desired setting.
- 5 Press **START/COPY/SET**.
- 6 Press **MENU**.

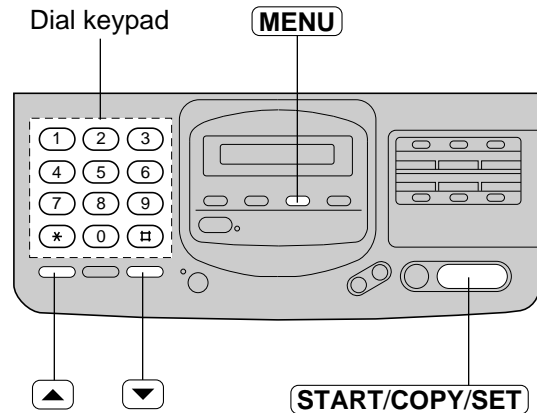

# Changing the display contrast

Use this feature to adjust the brightness of the display.

**NORMAL:** (Pre-selected setting)

**DARKER:** Used when the display contrast is too light.

- 1 Press **MENU**.  
SYSTEM SET UP
- 2 Press **⏏**, then **3** **9**.  
LCD CONTRAST
- 3 Press **START/COPY/SET**.  
MODE=NORMAL [▲▼]
- 4 Press **▲** or **▼** to select the desired setting.
- 5 Press **START/COPY/SET**.
- 6 Press **MENU**.

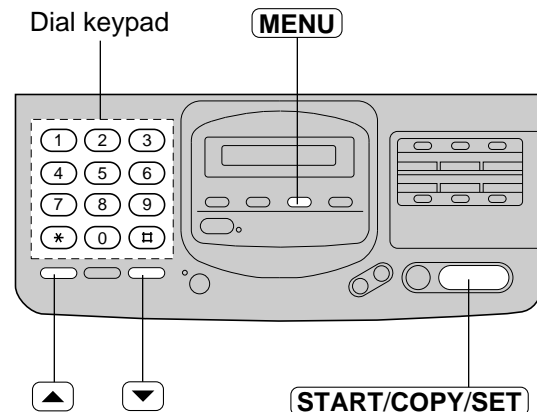

# Setting the friendly reception

The friendly reception feature allows you to receive fax documents automatically without pressing **START/COPY/SET**. See page 20 for further details.

If you set this feature to OFF, you will have to press **START/COPY/SET** to receive fax documents each time you answer a call.

- 1 Press **MENU**.  
SYSTEM SET UP
- 2 Press **Ⓜ**, then **4 6**.  
FRIENDLY RCV
- 3 Press **START/COPY/SET**.  
MODE=ON [▲▼]
- 4 Press **▲** or **▼** to select the desired setting.
- 5 Press **START/COPY/SET**.
- 6 Press **MENU**.

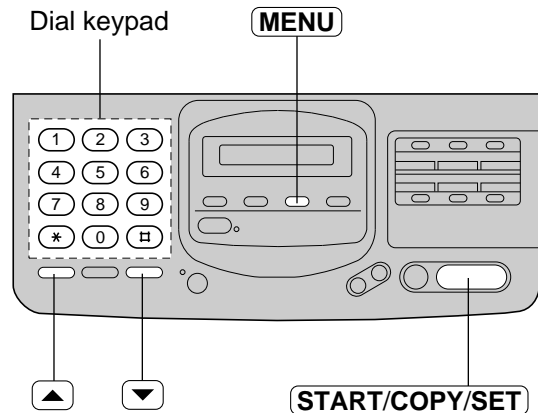

# Setting the handset switch

This unit work without the handset and handset cradle. When you do not use the handset and cradle, set this feature to NO HANDSET.

**USE HANDSET:** Choose when you use the handset and handset cradle (pre-selected setting).

**NO HANDSET:** Choose when you do not use the handset and handset cradle.

- 1 Press **MENU**.  
SYSTEM SET UP
- 2 Press **Ⓜ**, then **8 9**.  
HANDSET SWITCH
- 3 Press **START/COPY/SET**.  
USE HANDSET [▲▼]
- 4 Press **▲** or **▼** to select the desired setting.
- 5 Press **START/COPY/SET**.
- 6 Press **MENU**.

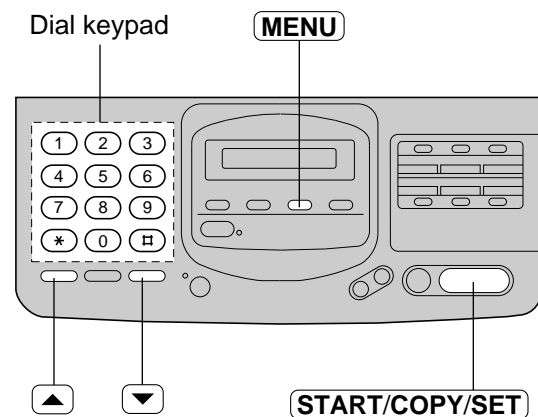

**Note:**

- After setting NO HANDSET, disconnect and connect the power cord again.

# Resetting the advanced features

Use this feature to return the advanced features (see page 45) to their pre-selected settings.

- 1 Press **MENU**.
- 2 Press **8 0**.
- 3 Press **START/COPY/SET**.
- 4 Press **▲** or **▼** to select "YES".
- 5 Press **START/COPY/SET**.
- 6 Press **START/COPY/SET** again for confirmation.
- 7 Press **MENU**.

SYSTEM SET UP

SET DEFAULT

RESET=NO [▲▼]

RESET=YES [▲▼]

RESET OK?

RESET COMPLETED

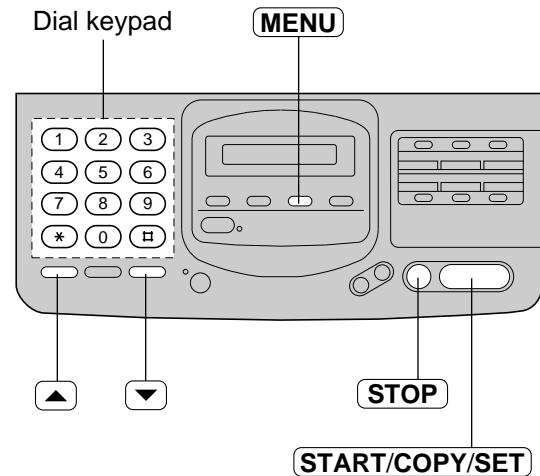

# Summary of user programmable features

## Basic features

| Code | Feature                   | Selection      | Initial setting | Page |
|------|---------------------------|----------------|-----------------|------|
| #01  | SET DATE & TIME           | mm/dd/yy hh:mm |                 | 11   |
| #02  | YOUR LOGO                 |                |                 | 12   |
| #03  | YOUR TELEPHONE NUMBER     |                |                 | 12   |
| #04  | PRINT TRANSMISSION REPORT | ERROR, ON, OFF | ERROR           | 47   |
| #05  | AUTO RECEIVE MODE         | FAX, EXT.TAM   | FAX             | 15   |
| #07  | FAX RING COUNT            | 1–4 rings      | 1 ring          | 21   |
| #08  | MANUAL RECEIVE MODE       | TEL, TEL/FAX   | TEL             | 15   |
| #09  | TEL/FAX DELAYED RING      | 1–4 rings      | 1 ring          | 23   |
| #12  | REMOTE TAM ACTIVATION     | ON, OFF        | OFF/ID=11       | 40   |

## Advanced features

| Code | Feature                     | Selection               | Initial setting | Page |
|------|-----------------------------|-------------------------|-----------------|------|
| #21  | LOGO POSITION               | OUT, IN                 | OUT             | 42   |
| #22  | JOURNAL AUTO PRINT          | ON, OFF                 | ON              | 47   |
| #23  | OVERSEAS MODE               | ON, OFF                 | OFF             | 33   |
| #24  | JUNK MAIL PROHIBITOR        | ON, OFF                 | OFF/ID=22       | 35   |
| #25  | DELAYED TRANSMISSION        | ON, OFF                 | OFF             | 32   |
| #30  | SILENT FAX RECOGNITION RING | 3–6 rings               | 3 rings         | 24   |
| #31  | RING DETECTION              | OFF, A, B, C, D         | OFF             | 36   |
| #39  | LCD CONTRAST                | NORMAL, DARKER          | NORMAL          | 42   |
| #40  | SILENT DETECTION            | ON, OFF                 | ON              | 41   |
| #41  | REMOTE FAX ACTIVATION CODE  | ON, OFF                 | ON/ID=* *       | 34   |
| #46  | FRIENDLY RECEPTION          | ON, OFF                 | ON              | 43   |
| #70  | FAX PAGER                   | ON, OFF                 | OFF             | 37   |
| #80  | SET DEFAULT                 | YES, NO                 | NO              | 44   |
| #89  | HANDSET SWITCH              | USE HANDSET, NO HANDSET | USE HANDSET     | 43   |

# Printing reports and lists

You can print out following reports and lists from your unit.

**Basic feature list**—provides you with the current settings of the basic features (see page 45).

**Advanced feature list**—provides you with the current settings of the advanced features (see page 45).

**Telephone number list**—provides you with phone numbers and their station names which are stored in automatic dialing. Codes in the phone number show;

P: A pause has been entered.

F: A flash has been entered.

[ ]: A secret phone number has been entered. (The telephone number is not printed.)

**Journal report**—keeps records of fax transmissions and receptions. This report will be printed automatically after every 35 fax communications, but can be printed manually. You can change the setting of the journal auto print feature (see page 47).

**Transmission report**—provides you with a printed record of the fax transmission result (see pages 47 and 48).

## How to print reports and lists

**1** Press **MENU** until the following is displayed.

PRINT LIST

**2** For the **basic feature list**, press **[#]**, then **1**.

BASIC LIST

For the **advanced list**, press **[#]**, then **2**.

ADVANCED LIST

For the **telephone number list**, press **[#]**, then **3**.

TEL NO. LIST

For the **journal report**, press **[#]**, then **4**.

JOURNAL REPORT

**3** Press **START/COPY/SET** to start printing.

- To interrupt printing, press **STOP**.

**4** After printing, press **MENU**.

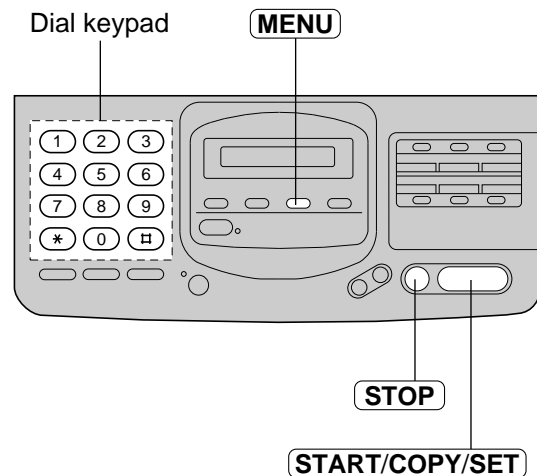

# Setting the transmission report printing

One of the following choices is available.

**ERROR:** The transmission report will print out only when fax transmission fails (pre-selected setting).

**ON:** The report will always print out, indicating whether fax transmission is successful or not.

**OFF:** The report will not print.

- 1 Press **MENU**.  
SYSTEM SET UP
- 2 Press **Ⓜ**, then **0 4**.  
TX-REPORT MODE
- 3 Press **START/COPY/SET**.  
MODE=ERROR [▲▼]
- 4 Press **▲** or **▼** to select the desired setting.
- 5 Press **START/COPY/SET**.
- 6 Press **MENU**.

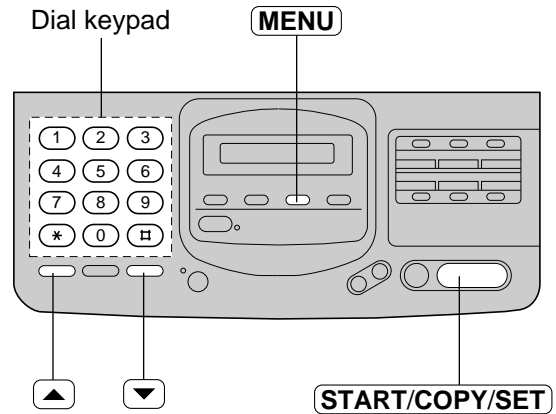

# Setting journal auto print

This unit will automatically print a journal report after every 35 fax communications. After printing, the journal memory will be erased and only subsequent activity will be recorded.

When this feature is deactivated, the unit will store the records of the last 35 fax communications, but the unit will not print the journal report automatically.

- 1 Press **MENU**.  
SYSTEM SET UP
- 2 Press **Ⓜ**, then **2 2**.  
AUTO JOURNAL
- 3 Press **START/COPY/SET**.  
MODE=ON [▲▼]
- 4 Press **▲** or **▼** to select the desired setting.
- 5 Press **START/COPY/SET**.
- 6 Press **MENU**.

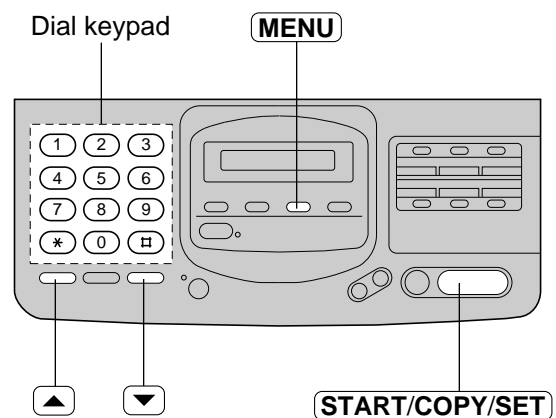

## Sample of journal report

| JOURNAL z |                 | JAN. 25 1996 05:22PM |            |      |       |                     |       |
|-----------|-----------------|----------------------|------------|------|-------|---------------------|-------|
| NO.       | OTHER FACSIMILE | START TIME           | USAGE TIME | MODE | PAGES | RESULT              | *CODE |
| 01        | 1234567         | JAN. 21 02:14PM      | 00'25      | TX   | 01    | OK                  |       |
| 02        | 9998765         | JAN. 21 02:17PM      | 00'38      | TX   | 02    | OK                  |       |
| 03        | 2121444         | JAN. 21 02:18PM      | 00'28      | RX   | 01    | OK                  |       |
| 04        | 555556677       | JAN. 22 10:35PM      | 00'58      | TX   | 03    | COMMUNICATION ERROR | (43)  |
| 05        |                 |                      | 01'50      | TX   | 05    | OK                  |       |
|           |                 |                      |            | RX   | 03    | OK                  |       |

## Sample of transmission report

| XMT REPORT z |                 | JAN. 20 1996 01:19PM |            |      |       |                     |       |
|--------------|-----------------|----------------------|------------|------|-------|---------------------|-------|
| NO.          | OTHER FACSIMILE | START TIME           | USAGE TIME | MODE | PAGES | RESULT              | *CODE |
| 01           | COMPANY ABC     | JAN. 20 01:18PM      | 00'51      | TX   | 00    | COMMUNICATION ERROR | (43)  |

Communication result (see below.)

Error code (for service personnel use only)

## Communication result on the report

When a problem has occurred, one of the following messages will be printed on the transmission and journal reports.

| PRINTED MESSAGE       | CODE        | MEANING                                                                              |
|-----------------------|-------------|--------------------------------------------------------------------------------------|
| COMMUNICATION ERROR   | 41-47<br>FF | A transmission or reception error occurred. Try again or check with the other party. |
| DOCUMENT JAMMED       | -           | The document is jammed. Remove the jammed document (see page 53).                    |
| JUNKMAIL PROH. REJECT | -           | The junk mail prohibitor of your unit rejected fax reception (see page 35).          |
| NO DOCUMENT           | -           | The document was not fed into the unit properly. Try again.                          |
| NO RESPONSE           | 40<br>52    | The receiving unit was busy or ran out of recording paper. Try again.                |
| PAPER JAMMED          | -           | The recording paper is jammed. Clear the jammed paper (see page 52).                 |
| PAPER OUT             | -           | The unit ran out of recording paper. Install a recording paper (see page 9).         |
| PRESSED THE STOP KEY  | -           | The STOP button was pressed, and fax communication was canceled.                     |
| PRINTER OVERHEATED    | -           | Printer was overheated. Let the unit cool down.                                      |
| THE COVER WAS OPENED  | -           | The back lid was open. Close it and try again.                                       |
| OK                    | -           | Fax communication was successful.                                                    |



# Error messages on the display

If the unit detects a problem, the following messages will appear on the display.

| DISPLAY MESSAGE | CAUSE AND REMEDY                                                                                                                                                                                                                                                                                                                                                                                                                                                                 |
|-----------------|----------------------------------------------------------------------------------------------------------------------------------------------------------------------------------------------------------------------------------------------------------------------------------------------------------------------------------------------------------------------------------------------------------------------------------------------------------------------------------|
| CALL SERVICE    | <ul style="list-style-type: none"> <li>There is something wrong with the unit. Contact our service personnel (see page 58).</li> </ul>                                                                                                                                                                                                                                                                                                                                           |
| CHECK COVER     | <ul style="list-style-type: none"> <li>The back lid is open. Close it.</li> </ul>                                                                                                                                                                                                                                                                                                                                                                                                |
| CHECK CRADLE    | <ul style="list-style-type: none"> <li>The handset and handset cradle have been removed when you connect the power cord.               <ul style="list-style-type: none"> <li>When you want to use the handset and handset cradle, install the handset cradle correctly (see page 8).</li> <li>When you do not use the handset and handset cradle, set the handset switch to NO HANDSET (see page 43). Then, disconnect and connect the power cord again.</li> </ul> </li> </ul> |
| CHECK DOCUMENT  | <ul style="list-style-type: none"> <li>The document is not fed into the unit properly. Reinsert the document. If the misfeeding occurs frequently, clean the document feeder rollers inside the unit (see page 55). If the problem remains, adjust the feeder pressure (see page 54).</li> </ul>                                                                                                                                                                                 |
| CHECK MEMORY    | <ul style="list-style-type: none"> <li>Memory (phone numbers, parameters, etc.) has been erased. Re-program.</li> </ul>                                                                                                                                                                                                                                                                                                                                                          |
| MECHA ERROR     | <ul style="list-style-type: none"> <li>A mechanical error occurred. Open the back lid and re-install the recording paper (see page 9).</li> </ul>                                                                                                                                                                                                                                                                                                                                |
| NO RESPONSE     | <ul style="list-style-type: none"> <li>The receiving unit is busy or ran out of recording paper. Try again.</li> </ul>                                                                                                                                                                                                                                                                                                                                                           |
| OUT OF PAPER    | <ul style="list-style-type: none"> <li>The unit ran out of recording paper. Install a new recording paper (see page 9).</li> </ul>                                                                                                                                                                                                                                                                                                                                               |
| PAPER JAMMED    | <ul style="list-style-type: none"> <li>A recording paper jam occurred. Clear the jammed paper (see page 52).</li> </ul>                                                                                                                                                                                                                                                                                                                                                          |
| POLLING ERROR   | <ul style="list-style-type: none"> <li>The other fax machine does not provide the polling function. Check with the other party.</li> </ul>                                                                                                                                                                                                                                                                                                                                       |
| REDIAL TIME OUT | <ul style="list-style-type: none"> <li>The receiving unit is busy or ran out of receiving paper. Try again.</li> </ul>                                                                                                                                                                                                                                                                                                                                                           |
| REMOVE DOCUMENT | <ul style="list-style-type: none"> <li>The document is jammed. Remove the jammed document (see page 53).</li> <li>Attempted to transmit a document longer than 600 mm (23 <sup>5</sup>/<sub>8</sub>" ). Press the STOP button and remove the document (see page 53). Divide the document into two or more sheets and try again.</li> </ul>                                                                                                                                       |
| TRANSMIT ERROR  | <ul style="list-style-type: none"> <li>A transmission error occurred. Try again.</li> </ul>                                                                                                                                                                                                                                                                                                                                                                                      |
| UNIT OVERHEATED | <ul style="list-style-type: none"> <li>The unit is too hot. Let the unit cool down.</li> </ul>                                                                                                                                                                                                                                                                                                                                                                                   |

# Before requesting help

## General

| PROBLEM                                                                      | CAUSE AND REMEDY                                                                                                                                                                                                                                                                                                |
|------------------------------------------------------------------------------|-----------------------------------------------------------------------------------------------------------------------------------------------------------------------------------------------------------------------------------------------------------------------------------------------------------------|
| I cannot make and receive calls.                                             | <ul style="list-style-type: none"><li>• The power cord or telephone line cord is not connected. Check the connections (see page 10).</li></ul>                                                                                                                                                                  |
| I cannot make calls.                                                         | <ul style="list-style-type: none"><li>• The dialing mode setting is wrong. Check the selector (see page 10).</li></ul>                                                                                                                                                                                          |
| The unit does not work.                                                      | <ul style="list-style-type: none"><li>• Disconnect the unit from the telephone line and connect to a known working phone. If the working phone operates properly, call your service center to have the unit repaired. If the working phone does not operate properly, contact your telephone company.</li></ul> |
| The unit does not ring.                                                      | <ul style="list-style-type: none"><li>• The ringer volume is set to OFF. Adjust to a suitable level (see page 16).</li></ul>                                                                                                                                                                                    |
| The REDIAL/PAUSE button does not function properly.                          | <ul style="list-style-type: none"><li>• If this button is pressed during dialing, a pause will be inserted. If this button is pressed immediately after obtaining a dial tone, the last number dialed will be redialed.</li></ul>                                                                               |
| During programming, I cannot enter the activation code or the prohibitor ID. | <ul style="list-style-type: none"><li>• Whole or part of the number is the same as another code or ID. Change the number (see pages 34, 35 and 40).</li></ul>                                                                                                                                                   |

## Fax Transmission

| PROBLEM                                                                                          | CAUSE AND REMEDY                                                                                                                                                                                                                                                                                                                        |
|--------------------------------------------------------------------------------------------------|-----------------------------------------------------------------------------------------------------------------------------------------------------------------------------------------------------------------------------------------------------------------------------------------------------------------------------------------|
| The other party complains that letters on their received document are distorted.                 | <ul style="list-style-type: none"><li>• If your line has special telephone services such as call waiting, the service may have been activated during fax transmission. Connect the unit to a line that does not have such services.</li><li>• An extension telephone on the same line is off the hook. Hang up and try again.</li></ul> |
| The other party complains that dirty patterns or black lines appear on their received documents. | <ul style="list-style-type: none"><li>• The glass or rollers are dirty. Clean them (see page 55).</li></ul>                                                                                                                                                                                                                             |
| I cannot make an international fax call.                                                         | <ul style="list-style-type: none"><li>• Use the overseas transmission mode (see page 33).</li><li>• Add two pauses at the end of the phone number (see page 30).</li></ul>                                                                                                                                                              |

## Fax Reception

| PROBLEM                                   | CAUSE AND REMEDY                                                                                                                                                                                                                                                                                     |
|-------------------------------------------|------------------------------------------------------------------------------------------------------------------------------------------------------------------------------------------------------------------------------------------------------------------------------------------------------|
| I cannot receive documents automatically. | <ul style="list-style-type: none"><li>• The receive mode is set to the TEL. Set to the EXT. TAM, TEL/FAX or FAX.</li><li>• The time to answer the call may be too long. Decrease the number of rings (see pages 21 and 23).</li><li>• The junk mail prohibitor is set to on (see page 35).</li></ul> |

## Fax Reception (cont.)

| PROBLEM                         | CAUSE AND REMEDY                                                                                                                                                                                      |
|---------------------------------|-------------------------------------------------------------------------------------------------------------------------------------------------------------------------------------------------------|
| The recording image is faint.   | <ul style="list-style-type: none"> <li>The sender transmitted a faint document. Request them to transmit a clearer copy of the document.</li> </ul>                                                   |
| The received document is blank. | <ul style="list-style-type: none"> <li>The recording paper roll is installed incorrectly. Make sure that the shiny side of the paper is facing down and re-install the paper (see page 9).</li> </ul> |

## Operation in EXT. TAM mode

| PROBLEM                                                                                                            | CAUSE AND REMEDY                                                                                                                                                                                                                                                                                                                                                                       |
|--------------------------------------------------------------------------------------------------------------------|----------------------------------------------------------------------------------------------------------------------------------------------------------------------------------------------------------------------------------------------------------------------------------------------------------------------------------------------------------------------------------------|
| I cannot receive documents automatically.                                                                          | <ul style="list-style-type: none"> <li>Your greeting message is too long. Shorten it (up to 10 seconds).</li> <li>There are too many rings on the answering machine. Set the number of rings to less than 4.</li> <li>The silent detection feature is deactivated. Activate this feature (see page 41).</li> </ul>                                                                     |
| I cannot receive voice messages.                                                                                   | <ul style="list-style-type: none"> <li>Check that the answering machine is turned on and connected to the facsimile unit properly (see page 38).</li> <li>Set the number of rings on the answering machine to less than 4.</li> </ul>                                                                                                                                                  |
| I cannot retrieve voice messages on the answering machine from a remote location.                                  | <ul style="list-style-type: none"> <li>The remote access code on your answering machine is the same as the remote fax activation code or the junk mail prohibitor ID on the facsimile unit. Set a different number for each code/ID.</li> <li>Your remote TAM activation code is not programmed correctly. Program the same code as on the answering machine (see page 40).</li> </ul> |
| The greeting message on your answering machine is interrupted halfway and the caller cannot leave a voice message. | <ul style="list-style-type: none"> <li>Silent pause in the greeting message is too long. Shorten it to less than 4 seconds.</li> </ul>                                                                                                                                                                                                                                                 |
| I pressed the remote access code to access the answering machine remotely, but the line was disconnected.          | <ul style="list-style-type: none"> <li>The code may include “#” which is used for certain features provided by the telephone company. Change the code on the answering machine not to include “#”. Then program the same code into the facsimile unit (see page 40).</li> </ul>                                                                                                        |

## Copying

| PROBLEM                                                          | CAUSE AND REMEDY                                                                                                                                                                                      |
|------------------------------------------------------------------|-------------------------------------------------------------------------------------------------------------------------------------------------------------------------------------------------------|
| A dirty pattern or a black line appears on the copied documents. | <ul style="list-style-type: none"> <li>The glass or rollers are dirty. Clean them (see page 55).</li> </ul>                                                                                           |
| The copied document is blank.                                    | <ul style="list-style-type: none"> <li>The recording paper roll is installed incorrectly. Make sure that the shiny side of the paper is facing down and re-install the paper (see page 9).</li> </ul> |

## If a power failure occurs

- This unit does not function during a power failure.
- The memory contents will not be erased.
- If the programmed start time has passed during a power failure, delayed transmission will be attempted after power is restored.

# Clearing a recording paper jam

If the unit does not eject any recording paper during reception or copying, the recording paper has jammed. Remove the jammed paper as shown below.

- 1
  - Ⓐ Open the back lid by lifting up the tabs located on both sides.
  - Ⓑ Press the green lever to release the paper cutter.

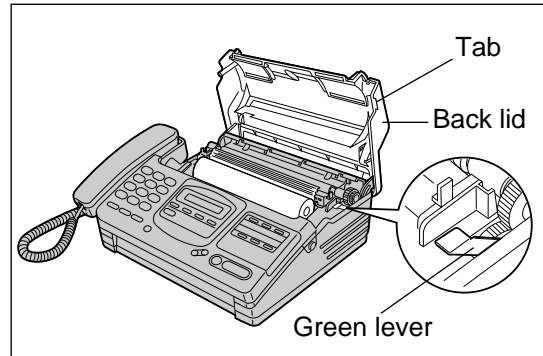

- 2 Pull up the transparent guide and remove the piece of paper.
  - If the transparent guide is not pulled up, press the green lever again.

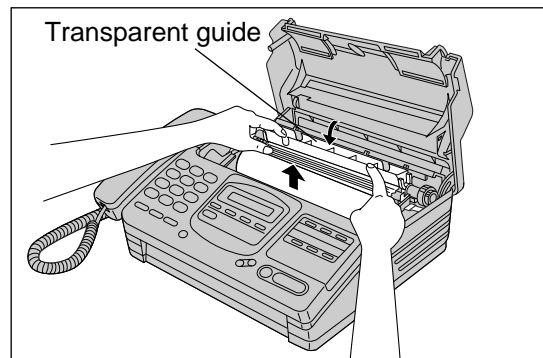

- 3 Replace the transparent guide and recording paper roll in the proper direction, and insert the leading edge of the paper between the recording paper roller and the silver plate.
  - Make sure that there is no slack in the paper roll.

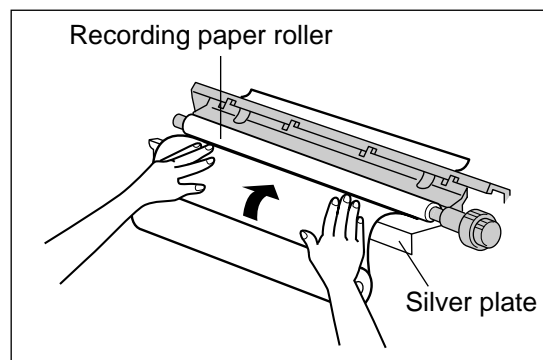

- 4 Close the back lid by gently pressing down on both ends.

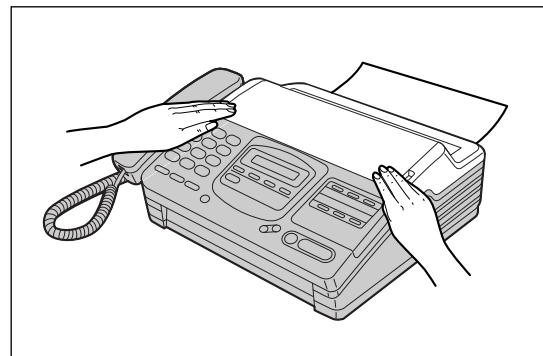

# Clearing a document jam

---

---

If the unit does not release an original document during feeding, remove it as shown below.

- 1** Open the front lid by pressing the front lid open button.
- 2** Remove the jammed document.
- 3** Close the front lid by gently pressing down on both ends.

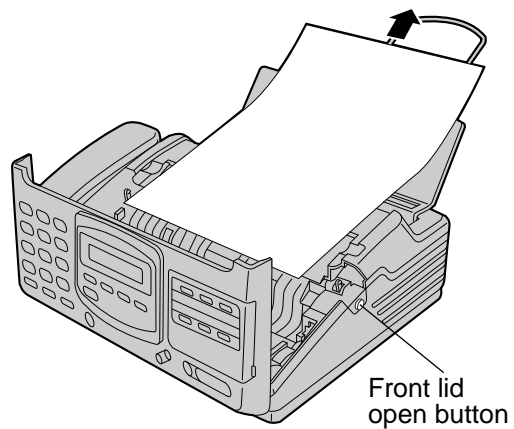

# Adjusting the feeder pressure

No feeding or multiple feeding occurs frequently, adjust the feeder pressure.

- 1 Open the front lid by pressing the front lid open button.
- 2 Shift the position of the lever by using an instrument with a pointed end, like a clip or ball-point pen.

Position A: Select this when documents do not feed.  
Position B: Standard position (pre-selected)  
Position C: Select this when documents multiple feed.

- 3 Close the front lid by gently pressing down on both ends.

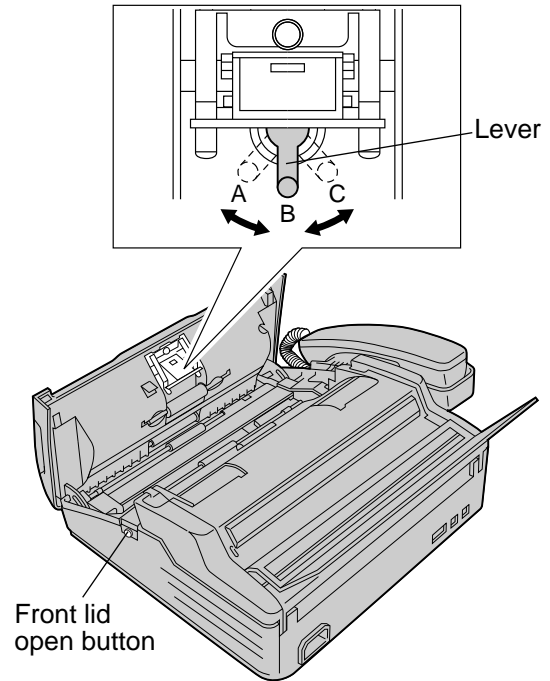

# Removing the handset cradle

To save space or to use the unit mainly for faxes, you may remove the handset cradle.

- 1 Set the handset switch to NO HANDSET (see page 43).
- 2 Pull the hooks to the right in the order as shown, while lifting up the handset cradle.
- 3 Disconnect and connect the power cord again.

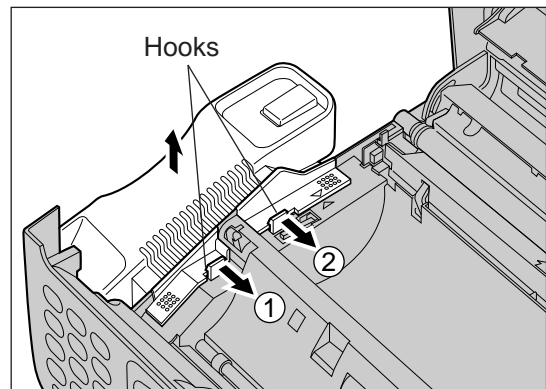

## Caution:

- If the handset and handset cradle have been removed when you connect the power cord, an alarm will sound and the following message will be displayed.

CHECK CRADLE

Set the handset switch to NO HANDSET (see page 43).

# Cleaning the inside of the unit

If misfeeding occurs frequently or dirty patterns or black bands appear on a copied or transmitted document, clean the document feeder rollers, sub roller, rubber flap, white plate and glass.

- 1** Disconnect the power cord and the telephone line cord.
- 2** Open the front lid by pressing the front lid open button.
- 3** Clean the document feeder rollers and sub roller with a cloth moistened with isopropyl rubbing alcohol, and let dry thoroughly.
- 4** Clean the rubber flap with a cotton swab moistened with isopropyl rubbing alcohol, and let dry thoroughly.
- 5** Clean the white plate and glass with a soft dry cloth.
- 6** Close the front lids by gently pressing down on both ends.
- 7** Connect the power cord and telephone line cord.

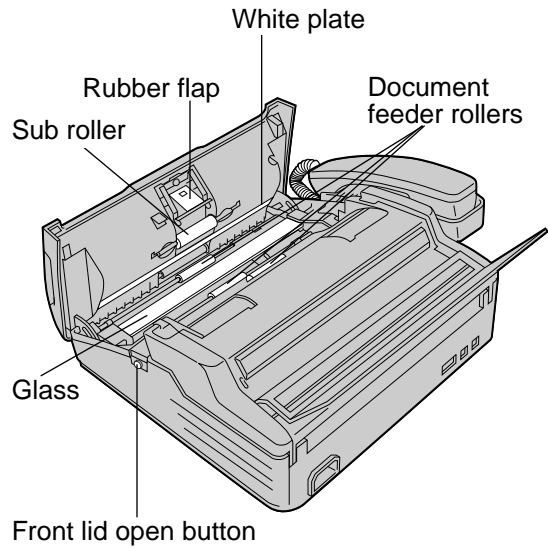

**Caution:**

- Do not use paper products (such as paper towels or tissues) to clean the inside of the unit.

# FCC information

---

---

If required by the telephone company, inform them of the following.

- FCC Registration No.:  
(found on the bottom of the unit)
- Ringer Equivalence No.:  
(found on the bottom of the unit)
- The particular telephone line to which the equipment is connected.

This unit must not be connected to a coin operated line. If you are on a party line, check with your local telephone company.

## **Ringer Equivalence Number (REN):**

This REN is useful in determining the quantity of devices you may connect to your telephone line and still have all of those devices ring when your telephone number is called. In most but not all areas, the sum of the REN's of all devices connected to one line should not exceed five (5.0). To be certain of the number of devices you may connect to your line, as determined by the REN, you should contact your local telephone company to determine the maximum REN for your calling area.

In the event that terminal equipment causes harm to the telephone network, the telephone company should notify the customer, if possible, that service may be stopped. However, where prior notice is impractical, the company may temporarily cease service providing that they:

- a) Promptly notify the customer.
- b) Give the customer an opportunity to correct the problem with their equipment.
- c) Inform the customer of the right to bring a complaint to the Federal Communication Commission pursuant to procedures set out in FCC Rules and Regulations Subpart E of Part 68.

The Telephone Company may make changes in its communications facilities, equipment operations, or procedures where such action is reasonably required in the operation of its business and is not inconsistent with the rules and regulations in FCC Part 68. If such changes can be reasonably expected to render any customer terminal equipment incompatible with telephone company communications facilities, or require modification or

alteration of such terminal equipment, or otherwise materially affect its use or performance, the customer shall be given adequate notice in writing, to allow the customer an opportunity to maintain uninterrupted service.

## **CAUTION:**

Any changes or modifications not expressly approved by the party responsible for compliance could void the user's authority to operate this device.

When programming emergency numbers and/or making test calls to emergency numbers:

1. Remain on the line and briefly explain to the dispatcher the reason for the call before hanging up.
2. Perform such activities in the off-peak hours; such as early morning or late evenings.

This telephone provides magnetic coupling to hearing aids.

## **NOTE:**

This equipment has been tested and found to comply with the limits for a Class B digital device, pursuant to Part 15 of the FCC Rules. These limits are designed to provide reasonable protection against harmful interference in a residential installation. This equipment generates, uses, and can radiate radio frequency energy and, if not installed and used in accordance with the instructions, may cause harmful interference to radio communications. However, there is no guarantee that interference will not occur in a particular installation. If this equipment does cause harmful interference to radio or television reception, which can be determined by turning the equipment off and on, the user is encouraged to try to correct the interference by one or more of the following measures:

- Reorient or relocate the receiving antenna.
- Increase the separation between the equipment and receiver.
- Connect the equipment into an outlet on a circuit different from that to which the receiver is connected.
- Consult the dealer or an experienced radio/TV technician for help.



**Matsushita Consumer Electronics Company,  
Division of Matsushita Electric Corporation of  
America**  
One Panasonic Way, Secaucus,  
New Jersey 07094

**Panasonic Sales Company  
Division of Matsushita Electric of  
Puerto Rico, Inc.**  
Ave. 65 de Infantería, Km. 9.5, San Gabriel  
Industrial Park, Carolina, Puerto Rico 00985

## **PANASONIC Facsimile Products Limited Warranty**

Matsushita Consumer Electronics Company or Panasonic Sales Company (collectively referred to as “the warrantor”), will repair this product with new or refurbished parts, free of charge, in the USA or Puerto Rico for one (1) year from the date of original purchase in the event of a defect in materials or workmanship.

**Batteries** (when applicable) — New rechargeable batteries in exchange for defective rechargeable batteries for ten (10) days from the date of original purchase. Non-rechargeable batteries are not warranted.

Carry-in or mail-in service in the USA or Puerto Rico can be obtained during the warranty period by contacting a Matsushita Services Company (MSC) Factory Servicenter listed in the Servicenter Directory. Or call, toll free, 1-800-HELP FAX (1-800-435-7329) to locate a MSC Factory Servicenter. Carry-in or mail-in service in Puerto Rico can be obtained during the warranty period by calling the Panasonic Sales Company telephone number listed in the Servicenter Directory.

This warranty is extended only to the original purchaser. A purchase receipt or other proof of date of original purchase will be required before warranty service is rendered.

This warranty only covers failures due to defects in material or workmanship which occur during normal use and (when applicable) does not cover the print and ink cartridge, the toner cartridge and drum unit or the film cartridge. The warranty does not cover damages which occurred in shipment, or failures which are caused by products not supplied by the warrantor, or failures which result from accident, misuse, abuse, neglect, mishandling, faulty installation, misapplication, set-up adjustments, improper operation or maintenance, alteration, modification, line power surge, improper voltage supply, lightning damage, signal reception problems, commercial use such as hotel, office, restaurant, or other business or rental use of the product, or serviced by anyone other than a MSC Factory Servicenter or a MSC authorized Servicenter, or damage that is attributable to acts of God.

### **LIMITS AND EXCLUSIONS**

There are no express warranties except as listed above.

THE WARRANTOR SHALL NOT BE LIABLE FOR INCIDENTAL OR CONSEQUENTIAL DAMAGES RESULTING FROM THE USE OF THIS PRODUCT, OR ARISING OUT OF ANY BREACH OF THIS WARRANTY. ALL EXPRESS AND IMPLIED WARRANTIES, INCLUDING THE WARRANTIES OF MERCHANTABILITY, ARE LIMITED TO THE APPLICABLE WARRANTY PERIOD SET FORTH ABOVE.

Some states do not allow the exclusion or limitation of incidental or consequential damages, or limitations on how long an implied warranty lasts, so the above exclusions or limitations may not apply to you.

This warranty gives you specific legal rights and you may also have other rights which vary from state to state. If a problem with this product develops during or after the warranty period, you may contact your dealer or Servicenter. If the problem is not handled to your satisfaction, then write to the Customer Satisfaction Center at the company address indicated above.

# Service center directory

## OPERATION ASSISTANCE FAX ADVANTAGE PROGRAM

DIAL TOLL FREE: 1-800-HELP-FAX (1-800-435-7329) (9:00am–8:00pm Monday–Friday, EST)

## PRODUCT INFORMATION LITERATURE REQUESTS DEALER LOCATIONS

Customer Satisfaction Center 2F-3, One Panasonic Way, Secaucus, NJ 07094 (Headquarters)  
201-348-9090 (9:00am–8:00pm Monday–Friday, EST)

## ACCESSORY PURCHASES

1-800-332-5368 (Consumer orders only)

**Matsushita Services Company** Accessory Order Office, 20421-84th Avenue South Kent, WA 98032  
(6:00am–6:00pm Monday–Friday, 6:00am–10:30am Saturday, PST)  
(Visa, Mastercard, Discover card, American Express, Check)

## AUTHORIZED SERVICENTERS

### CALIFORNIA

6550 Katella Avenue  
Cypress, CA 90630  
Phone (714) 373-7425  
Fax (714) 894-8534

800 Dubuque Avenue  
S. San Francisco,  
CA 94080  
Phone (415) 871-6373  
Fax (415) 871-6840

20201 Sherman Way  
Suite 102  
Canoga Park, CA 91306  
Phone (818) 709-1775  
Fax (818) 709-2165

3878 Ruffin Road  
Suite A  
San Diego, CA 92123  
Phone (619) 560-9200  
Fax (619) 560-1831

### COLORADO

1640 South Abilene Suite D  
Aurora, CO 80012  
Phone (303) 752-2024  
Fax (303) 752-0610

### FLORIDA

3700 North 29th Avenue  
Suite 102  
Hollywood, FL 33020  
Phone (954) 925-2880  
Fax (954) 925-5224

4710 Eisenhower  
Boulevard Suite A1  
Tampa, FL 33634  
Phone (813) 884-4746  
Fax (813) 886-4564

### GEORGIA

8655 Roswell Road  
Suite 100  
Atlanta, GA 30350  
Phone (770) 518-6301  
Fax (770) 518-6306

### HAWAII

99-859 Iwaiwa Street  
Aiea, Hawaii 96701  
Phone (808) 488-1996  
Fax (808) 486-4369

### ILLINOIS

\*1703 North Randall Road  
Elgin, IL 60123  
\*12:30 to 4:30, Mon-Fri\*  
Phone (847) 468-5464  
Fax (847) 468-5465

9060 Golf Road  
Niles, IL 60714  
Phone (847) 608-1010  
Fax (847) 299-1710

### MARYLAND

Sulphur Springs  
Business Park  
1638 Sulphur Springs Road  
Baltimore, MD 21227  
Phone (410) 242-2607  
Fax (410) 247-3047

### MASSACHUSETTS

60 Glacier Drive Suite G  
Westwood, MA 02090  
Phone (617) 329-4280  
Fax (617) 329-0586

\*pick-up/drop-off only

### MICHIGAN

37048 Van Dyke Avenue  
Sterling Heights, MI 48312  
Phone (810) 939-2060  
Fax (810) 939-2638

### MINNESOTA

7850-12th Avenue South  
Airport Business Center  
Bloomington, MN 55425  
Phone (612) 854-8624  
Fax (612) 854-2089

### OHIO

2236 Waycross Road  
Cincinnati, OH 45240  
Phone (513) 851-4180  
Fax (513) 851-8443

### PENNSYLVANIA

2221 Cabot Boulevard West  
Suite B  
Langhorne, PA 19047  
Phone (215) 741-0661  
Fax (215) 741-0521

Chartiers Valley  
Shopping Center  
1025 Washington Pike  
Bridgeville, PA 15017  
Phone (412) 257-4522  
Fax (412) 257-4650

### TENNESSEE

919-8th Avenue South  
Nashville, TN 37203  
Phone (615) 244-4434  
Fax (615) 244-6713

### TEXAS

7482 Harwin Drive  
Houston, TX 77036  
Phone (713) 781-1528  
Fax (713) 781-0643

13615 Welch Road  
Suite 101  
Farmers Branch, TX 75244  
Phone (214) 385-1975  
Fax (214) 960-7626

### WASHINGTON

20425-84th Avenue South  
Kent, WA 98032  
Phone (206) 872-7922  
Fax (206) 872-0918

### Service in Puerto Rico

**Matsushita Electric  
of Puerto Rico, Inc.  
Panasonic Sales Company/  
Factory Servicenter**

Ave. 65 de Infantería, Km. 9.5  
San Gabriel Industrial Park  
Carolina, Puerto Rico 00985  
Phone (809) 750-4300  
Fax (809) 768-2910

## REPAIR INQUIRIES

## Regional Customer Care Department

### EAST (PCE)

2221 Cabot Boulevard West  
Suite A  
Langhorne, PA 19047  
Phone (215) 741-0676  
Fax (215) 750-6492

#### Covers:

CT, DE, ME, MD, MA, NH, NJ,  
NY, PA, RI, VT, VA, DC, WV

### EAST (PCE)

1225 Northbrook Parkway  
Suite 2-390  
Suwanee, GA 30174  
Phone (404) 338-6860  
Fax (404) 338-6548

#### Covers:

AL, FL, GA, MS, NC, SC, TN

### CENTRAL (PCC)

1707 North Randall Road  
Elgin, IL 60123  
Phone (847) 468-5530  
Fax (847) 468-5528

#### Covers:

AR, IL, IN, IA, KS, KY, LA, MI,  
MN, MO, NE, ND, OK, SD, TX,  
WI, OH

### WEST (PCW)

6550 Katella Avenue  
Cypress, CA 90630  
Phone (714) 373-7440  
Fax (714) 373-7447

#### Covers:

AK, AZ, CA, CO, ID, MT, NV,  
NM, OR, UT, WA, WY, HI

## PARTS DISTRIBUTION LOCATIONS

To locate parts distributors in your area (within the USA)  
DIAL TOLL FREE 1-800-545-2672 (24 hours a day, 7 days a week)

(960607)

# Information for users

## For product service

- Service centers are listed on page 58.
- Call toll free 1-800-545-2672 for the location of an authorized service center.

## When you ship the product

- Carefully pack your unit, preferably in the original carton.
- Attach a letter, detailing the symptom or problem, to the outside of the carton.
- Send the unit to an authorized service center, prepaid and adequately insured.
- Do not send your unit to the Matsushita Consumer Electronics Company or to any executive or regional sales offices. These locations do not repair consumer products.

# Accessory order information

Use the following types of recording paper for replacement. For accessory order, call toll free 1-800-332-5368.

| Model No. | Description                                         | Comment                                                |
|-----------|-----------------------------------------------------|--------------------------------------------------------|
| KX-A106   | Standard Thermal Recording Paper                    | 216 mm -30 m (8 1/2" -98') roll, with 25 mm (1") core  |
| KX-A116   | Standard Thermal Recording Paper                    | 216 mm -50 m (8 1/2" -164') roll, with 25 mm (1") core |
| KX-A125   | Super Thermal Recording Paper<br>(Like plain paper) | 216 mm -30 m (8 1/2" -98') roll, with 25 mm (1") core  |

# Specifications

- |                                     |                                                                                                                                                                                                        |
|-------------------------------------|--------------------------------------------------------------------------------------------------------------------------------------------------------------------------------------------------------|
| <b>1. Applicable Lines:</b>         | Public Switched Telephone Network                                                                                                                                                                      |
| <b>2. Document Size:</b>            | Max. 216 mm (8½") in width<br>Max. 600 mm (23⅝") in length                                                                                                                                             |
| <b>3. Effective Scanning Width:</b> | 208 mm (8⅜")                                                                                                                                                                                           |
| <b>4. Printing Paper Size:</b>      | 216 mm ~max. 50 m (8½" ~164') roll                                                                                                                                                                     |
| <b>5. Effective Printing Width:</b> | 208 mm (8⅜")                                                                                                                                                                                           |
| <b>6. Transmission Time *:</b>      | Approx. 15 s/page (Original mode)<br>Approx. 30 s/page (G3 Normal mode)                                                                                                                                |
| <b>7. Scanning Density:</b>         | Horizontal: 8 pels/mm (203 pels/inch)<br>Vertical: 3.85 lines/mm (98 lines/inch) —Standard mode<br>7.7 lines/mm (196 lines/inch) —Fine/Halftone mode<br>15.4 lines/mm (392 lines/inch) —Superfine mode |
| <b>8. Halftone Level:</b>           | 64-level                                                                                                                                                                                               |
| <b>9. Scanner Type:</b>             | CCD image sensor                                                                                                                                                                                       |
| <b>10. Printer Type:</b>            | Thermal printing                                                                                                                                                                                       |
| <b>11. Data Compression System:</b> | Modified Huffman (MH), Modified READ (MR)                                                                                                                                                              |
| <b>12. Modem Speed:</b>             | 9600/7200/4800/2400 bps; Automatic Fallback                                                                                                                                                            |
| <b>13. Operating Environment:</b>   | 5–35°C (41–95°F), 45–85% RH (Relative Humidity)                                                                                                                                                        |
| <b>14. Dimensions (H -W -D):</b>    | 118 ~351 ~265 mm (4⅔" ~13⅓" ~10⅞")                                                                                                                                                                     |
| <b>15. Mass (Weight):</b>           | Approx. 3.7 kg (8.2 lb.)                                                                                                                                                                               |
| <b>16. Power Consumption:</b>       | Standby: Approx. 5 W<br>Transmission: Approx. 15 W<br>Reception: Approx. 35 W<br>Copy: Approx. 40 W<br>Maximum: Approx. 100 W                                                                          |
| <b>17. Power Supply:</b>            | 120 V AC, 60 Hz (This unit will not function at 50 Hz.)                                                                                                                                                |

\* Transmission speed depends upon the contents of the pages, resolution, telephone line conditions and capability of receiving unit. 15 second speed based upon CCITT No.1 Test Chart.

CCITT No.1 Test Chart



**Note:**

- Any details given in these instructions are subject to change without notice.
- The picture and illustrations in these instructions may vary slightly from the actual product.

## Speed dialer list

| Station No. | Name/Phone No. | Station No. | Name/Phone No. |
|-------------|----------------|-------------|----------------|
| 00          |                | 25          |                |
| 01          |                | 26          |                |
| 02          |                | 27          |                |
| 03          |                | 28          |                |
| 04          |                | 29          |                |
| 05          |                | 30          |                |
| 06          |                | 31          |                |
| 07          |                | 32          |                |
| 08          |                | 33          |                |
| 09          |                | 34          |                |
| 10          |                | 35          |                |
| 11          |                | 36          |                |
| 12          |                | 37          |                |
| 13          |                | 38          |                |
| 14          |                | 39          |                |
| 15          |                | 40          |                |
| 16          |                | 41          |                |
| 17          |                | 42          |                |
| 18          |                | 43          |                |
| 19          |                | 44          |                |
| 20          |                | 45          |                |
| 21          |                | 46          |                |
| 22          |                | 47          |                |
| 23          |                | 48          |                |
| 24          |                | 49          |                |

## Speed dialer list

| Station No. | Name/Phone No. | Station No. | Name/Phone No. |
|-------------|----------------|-------------|----------------|
| 00          |                | 25          |                |
| 01          |                | 26          |                |
| 02          |                | 27          |                |
| 03          |                | 28          |                |
| 04          |                | 29          |                |
| 05          |                | 30          |                |
| 06          |                | 31          |                |
| 07          |                | 32          |                |
| 08          |                | 33          |                |
| 09          |                | 34          |                |
| 10          |                | 35          |                |
| 11          |                | 36          |                |
| 12          |                | 37          |                |
| 13          |                | 38          |                |
| 14          |                | 39          |                |
| 15          |                | 40          |                |
| 16          |                | 41          |                |
| 17          |                | 42          |                |
| 18          |                | 43          |                |
| 19          |                | 44          |                |
| 20          |                | 45          |                |
| 21          |                | 46          |                |
| 22          |                | 47          |                |
| 23          |                | 48          |                |
| 24          |                | 49          |                |

# Index

---

---

|          |                                      |        |          |                                   |        |
|----------|--------------------------------------|--------|----------|-----------------------------------|--------|
| <b>A</b> | AUTO RECEIVE button .....            | 14     | <b>L</b> | Logo .....                        | 12     |
|          | AUTO RECEIVE mode .....              | 14     |          | Logo print position .....         | 42     |
|          | Automatic dialing .....              | 26, 27 |          | LOWER key .....                   | 26, 27 |
| <b>C</b> | Cleaning .....                       | 55     | <b>M</b> | MANUAL RECEIVE mode .....         | 14     |
|          | COPY button .....                    | 25     |          | MUTE button .....                 | 17     |
| <b>D</b> | Date and time .....                  | 11     | <b>O</b> | Overseas transmission mode .....  | 33     |
|          | Delayed transmission .....           | 32     | <b>P</b> | PAUSE button .....                | 30     |
|          | DELETE key .....                     | 13     |          | Polling .....                     | 31     |
|          | Dialing mode .....                   | 10     | <b>R</b> | REDIAL button .....               | 30     |
|          | DIRECTORY button .....               | 27, 28 |          | Remote fax activation code .....  | 34     |
|          | Display contrast .....               | 42     |          | Remote TAM activation ID .....    | 40     |
| <b>E</b> | Electronic telephone directory ..... | 28     |          | RESOLUTION button .....           | 18     |
|          | Error message .....                  | 49     |          | Ring pattern detection .....      | 36     |
|          | EXT.TAM mode .....                   | 14, 38 | <b>S</b> | SECRET key .....                  | 26     |
| <b>F</b> | Facsimile telephone number .....     | 12     |          | Set default .....                 | 44     |
|          | Fax auto redial .....                | 19     |          | Silent detection .....            | 41     |
|          | FAX mode .....                       | 21     |          | Silent fax recognition ring ..... | 24     |
|          | Fax pager .....                      | 37     |          | SPACE key .....                   | 13     |
|          | FAX ring count .....                 | 21     | <b>T</b> | TEL mode .....                    | 14     |
|          | Feeder pressure .....                | 54     |          | TEL/FAX mode .....                | 22     |
|          | FLASH button .....                   | 30     |          | TEL/FAX ring count .....          | 23     |
|          | Friendly reception .....             | 20, 43 |          | Telephone number list .....       | 46     |
| <b>H</b> | Handset switch .....                 | 43     |          | TONE button .....                 | 30     |
|          | HELP button .....                    | 10     |          | Transmission report .....         | 47     |
| <b>I</b> | INSERT key .....                     | 13     | <b>V</b> | Voice contact .....               | 29     |
| <b>J</b> | Journal auto print .....             | 47     |          | VOLUME button .....               | 16     |
|          | Journal report .....                 | 46     |          |                                   |        |
|          | Junk mail prohibitor .....           | 35     |          |                                   |        |

# Panasonic FAX ADVANTAGE PROGRAM

*We are proud to present the Panasonic Fax Advantage Program. It's an incredible service program that's full of exciting advantages!*

## Customer Satisfaction

In support of our one-year limited warranty \* (parts and labor) on our current fax product line, Panasonic is proud to offer you the following service options during the limited warranty period:

- 1 If you mail-in or carry-in your fax unit to one of our Regional Servicenters, the product will be repaired and returned to you, or .
- 2 If you call our 1-800-HELPFAX (1-800-435-7329) toll-free number, you will receive a refurbished replacement product overnight or on the second business day (delivery depending on the time of your call.)

## Support After The Sale

If you have a problem with your fax, just call our 1-800-HELPFAX (1-800-435-7329) toll-free number for friendly support and assistance. We have a highly-qualified team of experts who can diagnose, and most likely solve, your problem over the phone. Approximately 90% of our customers' problems are resolved with just a simple phone call.

The Fax Advantage Program covers the first year of purchase and works like this:

- 1 If you have a problem with your fax, call toll-free 1-800-HELPFAX (1-800-435-7329).
- 2 Talk to one of our experienced technical experts to diagnose (and most likely solve) your problem over the phone.
- 3 Providing that you may be entitled to Panasonic's service under the terms and conditions of the limited warranty \*\*, we will arrange for a reconditioned replacement unit to be shipped to you overnight or second business day delivery, depending on the time of your call. The replacement unit will be completely refurbished, quality-tested by Panasonic technicians, and individually hand-inspected before it is shipped to you. You will keep the replacement unit and send your original unit to us, along with a copy of your receipt.

4 This receipt must be shipped back with your original unit to Panasonic Company (as per instructions enclosed in your replacement unit's box).

Any unit that is replaced by Panasonic and not backed up by a proof of purchase by you will be subject to a minimum \$100.00 charge. Any unit that is replaced, but does not meet the terms and conditions of the limited warranty will be subject to additional charges, as per the program guidelines.

5 Once you receive your replacement unit, pack up your problem unit in the replacement unit's box. UPS will make 3 attempts within 10 days to pick-up your defective unit at no charge to you (should you be entitled to warranty service. If warranty conditions do not apply, you will be charged for all applicable shipping charges). The product must be properly packaged in the same manner as the replacement unit, utilizing the packing materials provided. You must make your unit available for UPS pick-up. If your unit is not available for



## Requirements:

6 You must give our technicians a valid credit card number. They will change your card account to cover any charges that are incurred by failure to send the problem product to Panasonic Company. If your problem unit is not eligible for warranty, you will be charged for the repair of the unit and for any shipping charges associated with this program. If you do not wish to pay out-of-warranty repair costs, you will be responsible for returning the replacement unit to Panasonic and for paying all shipping charges associated with this program including the overnight delivery of replacement product to you, shipment of problem unit to Panasonic, the replacement unit back to Panasonic and the return of your original unit back to you.

### Acceptable credit cards:

Discover VISA  
Master Card American Express (Optima)

Product that is not returned to Panasonic by 10 business days after shipment of the replacement product, will be charged to your account at Panasonic's Suggested Retail Price (see dealer for details).

Credit status will be verified prior to sending the replacement product.

Proof of Purchase must be included with the returned unit to verify warranty status.

Any parts and labor that are not covered by the limited warranty\* will be charged as a non-warranty repair and billed at Panasonic's current rate for parts and labor.

\*See the warranty stipulations in these instructions.

\*\*Replacement program excludes Puerto Rico and is subject to termination at any time without advance notice.

**Matsushita Consumer Electronics Company, Division of Matsushita Electric Corporation of America**  
One Panasonic Way, Secaucus,  
New Jersey 07094

**Panasonic Sales Company, Division of Matsushita Electric of Puerto Rico, Inc. ("PSC")**  
Ave. 65 de Infantería, Km. 9.5  
San Gabriel Industrial Park, Carolina,  
Puerto Rico 00985



## Free Manuals Download Website

<http://myh66.com>

<http://usermanuals.us>

<http://www.somanuals.com>

<http://www.4manuals.cc>

<http://www.manual-lib.com>

<http://www.404manual.com>

<http://www.luxmanual.com>

<http://aubethermostatmanual.com>

Golf course search by state

<http://golfingnear.com>

Email search by domain

<http://emailbydomain.com>

Auto manuals search

<http://auto.somanuals.com>

TV manuals search

<http://tv.somanuals.com>