



Panasonic

Compact Plain Paper Fax
with Digital Cordless Phone

Operating Instructions

Model No. **KX-FC235AL**
KX-FC231NZ



Please read these operating instructions before using the unit and save for future reference.

This unit is compatible with Caller ID and SMS (SMS is for KX-FC235AL only). To use these features, you must subscribe to the appropriate service of your service provider.

Be sure to use the telephone line cord included in this unit.

How to use the operating instructions

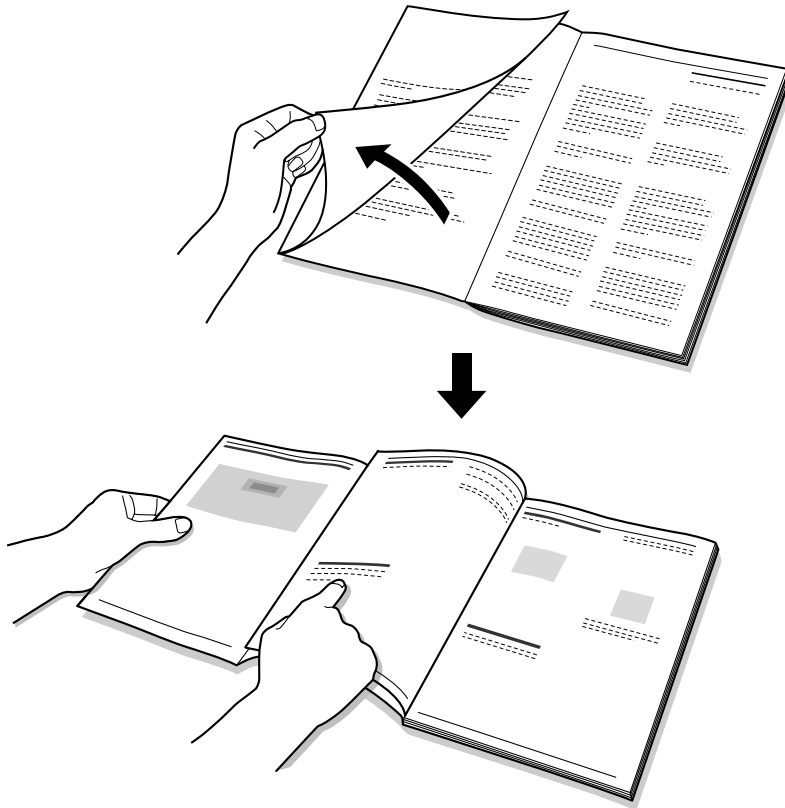

When following operating instructions, always keep the front cover page (next page) open for easy reference to the buttons.

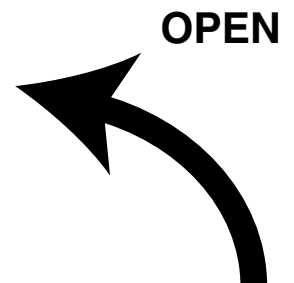

Location of Controls

Please keep this page open when following operating instructions.
For a description of each button, see page 12, 13.

Base unit

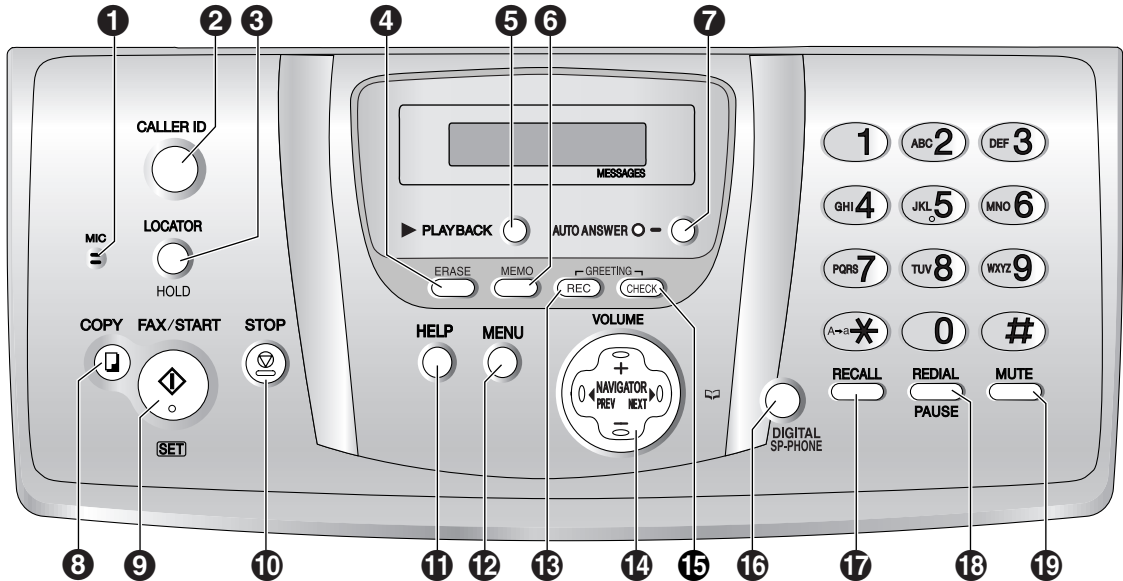

Buttons (Listed in alphabetical order)

- | | | |
|---------------------|--------------|------------|
| AUTO ANSWER 7 | HELP 11 | PAUSE 18 |
| CALLER ID 2 | HOLD 3 | PLAYBACK 5 |
| COPY 8 | LOCATOR 3 | RECALL 17 |
| DIGITAL SP-PHONE 16 | MEMO 6 | REDIAL 18 |
| ERASE 4 | MENU 12 | SET 9 |
| FAX/START 9 | MIC 1 | START 9 |
| GREETING/CHECK 15 | MUTE 19 | STOP 10 |
| GREETING/REC 13 | NAVIGATOR 14 | VOLUME 14 |

Handset

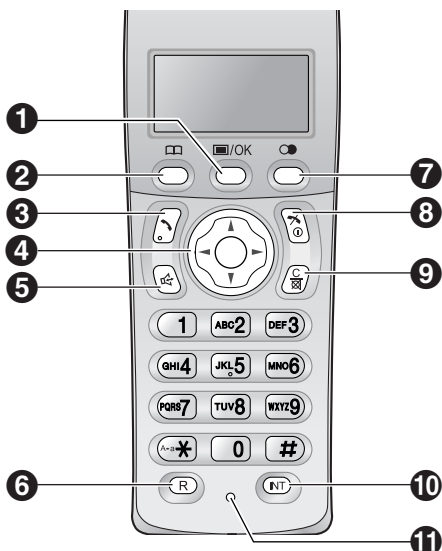

Buttons

- Menu/OK (Menu/OK) 1
- (Phonebook) 2
- (Talk) 3
- Navigator 4
- (Speakerphone) 5
- R (Recall) 6
- (Redial/Pause) 7
- (Off/Power) 8
- C/ (Clear/Mute) 9
- INT (Intercom) 10
- Microphone 11

Thank you for purchasing a Panasonic fax machine.

For your future reference

Date of purchase

Serial number (found on the rear of the unit)

Dealer's name and address

Dealer's telephone number

Attach your sales receipt here.



Caution:

- Note that the images of copied or received documents will remain on the used ink film. Use discretion when disposing of the used ink film.
- Do not rub or use an eraser on the printed side of recording paper, as the print may smear.
- In the event of problems, you should contact your equipment supplier in the first instance.

KX-FC235AL:

- This equipment is designed for use on the Australia network.

KX-FC231NZ:

- This equipment is designed for use on the New Zealand network.

Trademarks:

- Eaton and LetterWise are trademarks of Eaton Ergonomics, Inc.

For Australian users

Warning:

- Please ensure that a separate telephone, not dependent on local power, is available for emergency use.
- This equipment will be inoperable when mains power fails.
- When a failure occurs which results in the internal parts becoming accessible, disconnect the power supply cord immediately and return this unit to an authorised service centre.
- Disconnect the telephone connection before disconnecting power connection prior to relocating the equipment, and reconnect the power first.
- To minimize the possibility of lightning damage, when you know that a thunderstorm is coming, we recommend that you:
 - A. Unplug the telephone line cord from the phone jack.
 - B. Unplug the power supply cord from the AC power outlet.
- No "000" or other calls can be made from this device during a mains power failure.
- The earcap on the handset is magnetised and may retain metallic objects.

For New Zealand users

Warning:

- WHEN A FAILURE OCCURS WHICH RESULTS IN THE INTERNAL PARTS BECOMING ACCESSIBLE, DISCONNECT THE POWER SUPPLY CORD IMMEDIATELY AND RETURN THIS UNIT TO AN AUTHORISED SERVICE CENTRE.
- DISCONNECT THE TELECOM CONNECTION BEFORE DISCONNECTING THE POWER CONNECTION PRIOR TO RELOCATING THE EQUIPMENT, AND RECONNECT THE POWER FIRST.
- NO "111" OR OTHER CALLS CAN BE MADE FROM THIS DEVICE DURING A MAINS POWER FAILURE.

IMPORTANT NOTICE

Under power failure conditions, this telephone may not operate. Please ensure that a separate telephone, not dependent on local power, is available for emergency use.

Notice:

- The grant of a Telepermit for any item of terminal equipment indicates only that Telecom has accepted that the item complies with minimum conditions for connection to its network. It indicates no endorsement of the product by Telecom, nor does it provide any sort of warranty. Above all, it provides no assurance that any item will work correctly in all respects with another item of Telepermitted equipment of a different make or model, nor does it imply that any product is compatible with all of Telecom's network services.
- This equipment shall not be set to make automatic calls to the Telecom "111" Emergency Service.
- This equipment should not be used under any circumstances which may constitute a nuisance to other Telecom customers.
- Not all telephones will respond to incoming ringing when connected to the extension socket.
- This equipment may not provide for the effective hand-over of a call to another device connected to the same line.

Important information (for Australian users)

Instructions to customer

Installation

Attached to this apparatus is an approval label. This label is evidence that it is a "Permitted Attachment" which has been authorised to be connected to your telephone service.

Conditions relating to connection and operation of this Permitted Attachment are contained in Telecommunications General By-Law 220 (5).

You are authorised to install this Permitted Attachment yourself by plugging it into the line socket of any regular telephone. You may connect it in place of your existing telephone or to any spare telephone socket installed in your premises.

To disconnect your existing telephone you must first remove its plug from the line socket. You can then insert the plug of your Permitted Attachment into the socket and use your equipment.

If the plug of your existing telephone cannot be readily removed, you will have to remove the screw securing it. To do this proceed as follows:

1. Loosen screw "A" sufficiently to remove the socket cover. (See Fig. 1.)
2. Remove screw "B" and withdraw the plug. (See Fig. 2.)
3. Replace screw "B". (See Fig. 3.) Ensure that it screws completely into the socket recess. (If the screw is too long, increase the hole depth or replace the screw with one 5 mm shorter.)
4. Replace socket cover and tighten screw "A". (See Fig. 4.)

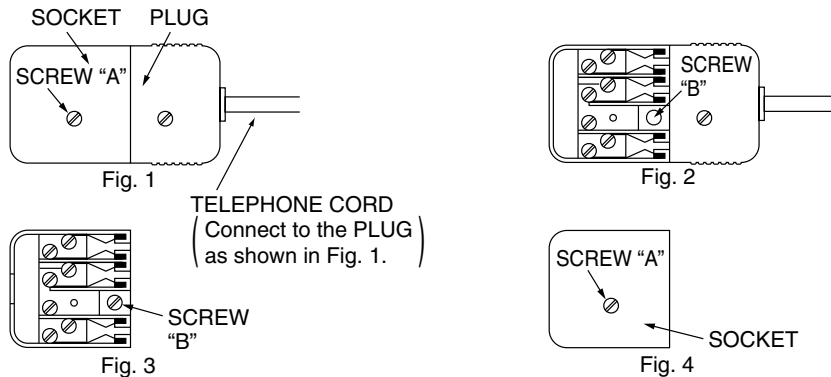

If you are satisfied with the operation of your telephone service after plugging in your Permitted Attachment, your installation is completed.

You will be unable to connect this Permitted Attachment if your telephone service consists only of a wall phone or an old style telephone which is not connected by means of a modern plug and socket. In such cases a new socket will need to be installed.

Should the Permitted Attachment not operate when plugged into a socket, it is either faulty or unsuitable for operation with your telephone service. It should be returned to the store where purchased.

Service difficulties

If at any time a fault occurs on your telephone service carry out the following checks before you call for service:

- Disconnect the Permitted Attachment and try using the service with the normal telephone.
- If the telephone service then operates satisfactorily, the fault is in your Permitted Attachment. Leave the Permitted Attachment disconnected and report the fault to its supplier or agent to arrange for repair.
- If when using the telephone the service is still faulty, report the fault to "Service Difficulties and Faults" for attention.

You are required to keep this Permitted Attachment in good working order while it is connected to your telephone service. Its construction or internal circuit must not be modified in any way without permission.

WARNING

This cordless telephone system does not incorporate provision for secrecy of conversations.

Appropriately tuned radio equipment and other cordless telephone systems in close proximity may be used by a third party to monitor and possibly interrupt conversations in progress when this system is on radio operation.

Important safety instructions

When using this unit, basic safety precautions should always be followed to reduce the risk of fire, electric shock, or personal injury.

1. Read and understand all instructions.
2. Follow all warnings and instructions marked on this unit.
3. Unplug this unit from power outlets before cleaning. Do not use liquid or aerosol cleaners. Use a damp cloth for cleaning.
4. Do not use this unit near water, for example near a bathtub, wash bowl, kitchen sink, etc.
5. Place the unit securely on a stable surface. Serious damage and/or injury may result if the unit falls.
6. Do not cover slots and openings on the unit. They are provided for ventilation and protection against overheating. Never place the unit near radiators, or in a place where proper ventilation is not provided.
7. Use only the power source marked on the unit. If you are not sure of the type of power supplied to your home, consult your dealer or local power company.
8. For safety purposes this unit is equipped with a grounded plug. If you do not have this type of outlet, please have one installed. Do not defeat this safety feature by tampering with the plug.
9. Do not place objects on the power cord. Install the unit where no one can step or trip on the cord.
10. Do not overload power outlets and extension cords. This can result in the risk of fire or electric shock.
11. Never push any objects through slots in this unit. This may result in the risk of fire or electric shock. Never spill any liquid on the unit.
12. To reduce the risk of electric shock, do not disassemble this unit. Take the unit to an authorised service centre when service is required. Opening or removing covers may expose you to dangerous voltage or other risks. Incorrect reassembly can cause electric shock when the unit is subsequently used.
13. Unplug this unit from power outlets and refer servicing to an authorised service centre when the following conditions occur:
 - A. When the power cord is damaged or frayed.
 - B. If liquid has been spilled into the unit.
 - C. If the unit has been exposed to rain or water.
 - D. If the unit does not work normally by following the operating instructions. Adjust only controls covered by the operating instructions. Improper adjustment may require extensive work by an authorised service centre.
 - E. If the unit has been dropped or physically damaged.
 - F. If the unit exhibits a distinct change in performance.
14. During thunderstorms, avoid using telephones except cordless types. There may be a remote risk of an electric shock from lightning.
15. Do not use this unit to report a gas leak, when in the vicinity of the leak.
16. It is advised not to use the equipment at a refuelling point. Users are reminded to observe restrictions on the use of radio equipment in fuel depots, chemical plants or where blasting operations are in progress.

SAVE THESE INSTRUCTIONS

CAUTION:

stopped and contact an authorised service centre.

Installation

- Never install telephone wiring during a lightning storm.
- Never install telephone jacks in wet locations unless the jack is specifically designed for wet locations.
- Never touch uninsulated telephone wires or terminals unless the telephone line has been disconnected at the network interface.
- Use caution when installing or modifying telephone lines.
- Do not touch the plug with wet hands.
- This unit should not be used near emergency/intensive care medical equipment and should not be used by people with pacemakers.

Battery

To reduce the risk of fire or injury to persons, read and follow these instructions.

- Use only the battery(ies) specified.
- Do not dispose of the battery(ies) in a fire. They may explode. Check with local waste management codes for special disposal instructions.
- Do not open or mutilate the battery(ies). Released electrolyte is corrosive and may cause burns or injury to the eyes or skin. The electrolyte may be toxic if swallowed.
- Exercise care when handling the battery(ies). Do not allow conductive materials such as rings, bracelets or keys to touch the battery(ies), otherwise a short circuit may cause the battery(ies) and/or the conductive material to overheat and cause burns.
- Charge the battery(ies) provided with or identified for use with this product only in accordance with the instructions and limitations specified in these operating instructions.
- Only use the included base unit (or charger) to charge the battery(ies). Do not tamper with the base unit (or charger). Failure to follow these instructions may cause the battery(ies) to swell or explode.

WARNING:

- To prevent the risk of fire or electrical shock, do not expose this product to rain or any type of moisture.
- Unplug this unit from power outlets if it emits smoke, an abnormal smell or makes unusual noise. These conditions can cause fire or electric shock. Confirm that smoke has

For best performance

Battery charge

- Place the handset on the cradle of the base unit for about **7 hours** before initial use.
- For details, see page 22.

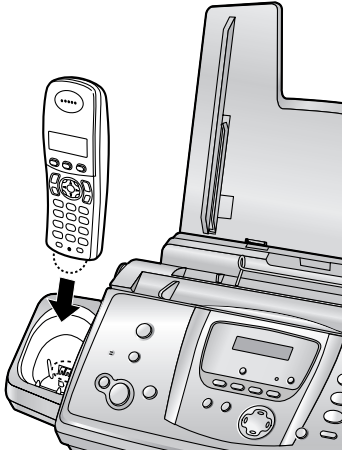

Operating distance and noise

- The base unit and handset use radio waves to communicate with each other.
- For maximum distance and noise-free operation, we recommend the following:**

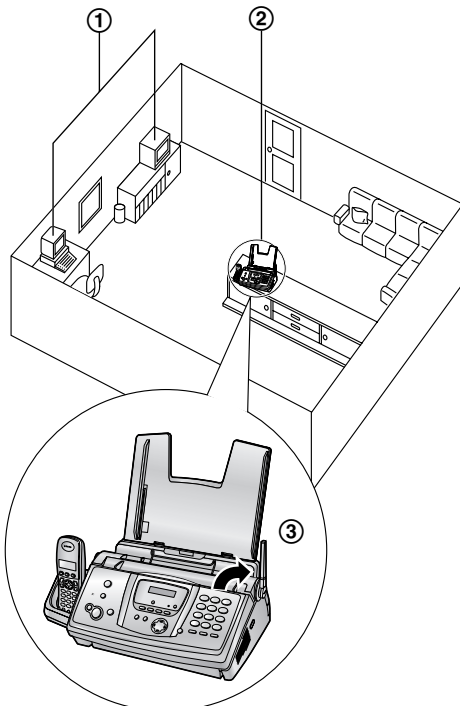

- ① Placing your base unit away from electrical appliances such as TVs, radios, personal computers or other phones.
- ② Placing the base unit in a HIGH and CENTRAL location with no obstructions such as walls.
- ③ Raising the antenna vertically.

Environment

- Keep the unit away from electrical noise generating devices, such as fluorescent lamps and motors.
- The unit should be kept free from dust, high temperature and vibration.
- The unit should not be exposed to direct sunlight.
- Do not place heavy objects on top of the unit.
- The unit should be kept away from heat sources such as heaters, kitchen stoves, etc. It should not be placed in rooms where the temperature is less than 5 °C or greater than 35 °C (base unit) / 40 °C (handset). Damp basements should also be avoided.

Routine care

- Wipe the outer surface of the unit with a soft cloth. Do not use benzine, thinner, or any abrasive powder.

Recording paper

- Store unused paper in the original packaging, in a cool and dry place. Not doing so may affect print quality.

1. Introduction

Accessories

- 1.1 Included accessories 10
- 1.2 Accessory information 11

Finding the Controls

- 1.3 Button descriptions of the base unit . 12
- 1.4 Button descriptions of the handset... 13
- 1.5 Display descriptions of the handset.. 14
- 1.6 Overview 15

2. Installation

Base Unit

- 2.1 Ink film installation / replacement 16
- 2.2 Paper tray 18
- 2.3 Recording paper 19

Handset

- 2.4 Battery installation / replacement 20

3. Preparation

Connections and Setup

- 3.1 Connections 21
- 3.2 Battery charge 22
- 3.3 Turning the handset power ON/OFF 23

Help Button

- 3.4 Base unit help function 23

Volume

- 3.5 Adjusting handset volume 24
- 3.6 Adjusting base unit volume..... 24

Initial Programming

- 3.7 Date and time 25
- 3.8 Your logo..... 26
- 3.9 Your fax number 28

4. Telephone

Making and Answering Calls

- 4.1 Making phone calls..... 29
- 4.2 Answering phone calls..... 31

Automatic Dialling

- 4.3 Handset phonebook 31
- 4.4 Base unit phonebook..... 34

Caller ID

- 4.5 Caller ID service 35
- 4.6 Viewing and calling back using caller information..... 37
- 4.7 Editing a caller's telephone number before calling back..... 38
- 4.8 Erasing caller information 38
- 4.9 Storing caller information into the phonebook..... 39
- 4.10 Voice mail service (for Australian users only)..... 40
- 4.11 Call minder (for New Zealand users only)..... 40

5. SMS (KX-FC235AL only)

SMS

- 5.1 SMS (Short Message Service)..... 41
- 5.2 Turning SMS ON/OFF 41
- 5.3 Changing SMS message centre numbers 41
- 5.4 Sending a message..... 42
- 5.5 Receiving a message 43
- 5.6 Guide to SMS settings..... 45
- 5.7 Available character entries for SMS . 46

6. Fax

Sending Faxes

- 6.1 Sending a fax manually 48
- 6.2 Documents you can send 49
- 6.3 Sending a fax using the base unit phonebook..... 50
- 6.4 Broadcast transmission 50

Receiving Faxes

- 6.5 Selecting the way to use your fax machine..... 52
- 6.6 Auto receive..... 52
- 6.7 Manual receive 53
- 6.8 Receiving a fax manually – Auto answer OFF 54
- 6.9 Receiving a fax automatically – Auto answer ON..... 55
- 6.10 Receive polling (retrieving a fax placed on another fax machine)..... 56
- 6.11 Junk fax prohibitor (preventing fax reception from undesired callers) 57

7. Distinctive Ring

Distinctive Ring

- 7.1 Using with the ring detection feature 58

8. Copy

Copying

- 8.1 Making a copy 59

9. Answering Machine

Greeting

- 9.1 Recording your greeting message.... 61

Incoming Messages

- 9.2 Listening to recorded messages 62

Memo Message

- 9.3 Leaving a message for others or yourself 62

Remote Operation

- 9.4 Operating from a remote location..... 64

10. Programmable Features

Base Unit

- 10.1 Base unit programming 66
- 10.2 Basic features..... 67
- 10.3 Advanced features..... 68
- 10.4 Direct commands for programming features..... 71

Handset

- 10.5 Handset programming 73

11. Multi-unit Operation

Additional Units

- 11.1 Operating additional units..... 81
- 11.2 Registering a handset to a base unit 81
- 11.3 Handset locator 82
- 11.4 Intercom between handsets 83
- 11.5 Transferring calls between handsets / Conference calls..... 83
- 11.6 Copying handset phonebook items .. 84

12. Useful Information

Useful Information

- 12.1 Available character entries for the handset..... 85

13. Help

Error Messages

- 13.1 Error messages – Reports 87
- 13.2 Error messages – Base unit display . 88

Troubleshooting

- 13.3 When a function does not work, check here 90

Jams

- 13.4 Recording paper jams 98
- 13.5 Document jams – sending..... 101

Cleaning

- 13.6 Document feeder / scanner glass cleaning 102
- 13.7 Thermal head cleaning..... 103

14. General Information

Printed Reports

- 14.1 Reference lists and reports (Base unit only)..... 105

Specifications

- 14.2 Specifications 106

15. Index

- 15.1 Index..... 108

1.1 Included accessories

No.	Item	Quantity	Notes
①	Power cord	1	-----
②	Telephone line cord	1	For Australian users (Australian type plug) For New Zealand users (New Zealand BT type plug)
③	Paper tray	1	-----
④	Starter ink film (10 metres long)	1	prints about 28 A4-sized pages.*1
⑤	Handset	1	-----
⑥	Rechargeable batteries	2	AAA (R03) size
⑦	Handset cover	1	-----
⑧	Operating instructions	1	-----
⑨	Quick installation guide	1	-----

*1 For replacement film, see page 11.

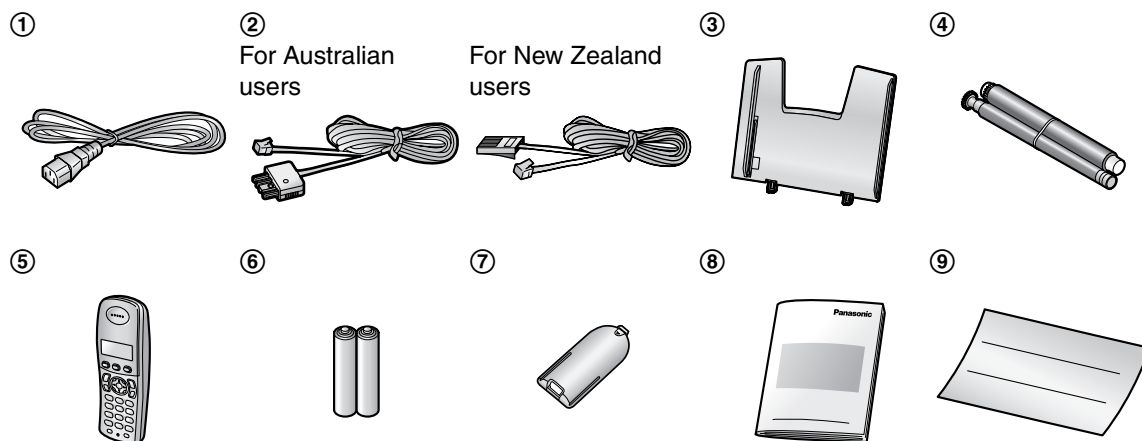

Note:

- If any items are missing or damaged, contact the place of purchase.
- Save the original carton and packing materials for future shipping and transportation of the unit.

1.2 Accessory information

1.2.1 Available accessories

Additional/replacement accessories

Model No.	Item	Specifications/Usage
KX-FA54E	Replacement film* ¹	35 m × 2 rolls (Each roll will print about 105 A4-sized pages.)
HHR-4EPT	Rechargeable batteries	2 rechargeable nickel metal hydride (Ni-MH) batteries
KX-TGA121AZ	Additional handset	-----
KX-A272	DECT repeater	-----

*1 We recommend that you buy a full-size replacement film for continuous use of your unit. Please use genuine Panasonic replacement film. **The ink film is not reusable. Do not rewind and use the ink film again.**

For Users in New Zealand

General Warning:

The grant of a Telepermit for any item of terminal equipment indicates only that Telecom has accepted that the item complies with minimum conditions for connection to its network. It indicates no endorsement of the product by Telecom, nor does it provide any sort of warranty. Above all, it provides no assurance that any item will work correctly in all respects with another item of Telepermitted equipment of a different make or model, nor does it imply that any product is compatible with all of Telecom's network services.

Important Notice:

Under power failure conditions, this telephone may not operate. Please ensure that a separate telephone, not dependent on local power, is available for emergency use.

1.3 Button descriptions of the base unit

- Keep the front cover page open for button locations.
- 1 [MIC] (Microphone)**
 - The built-in microphone.
- 2 [CALLER ID]**
 - To use Caller ID features (page 37).
- 3 [LOCATOR][HOLD]**
 - To locate a handset (page 82).
 - To put a call on hold.
- 4 [ERASE]**
 - To erase messages (page 61, 62).
- 5 [PLAYBACK]**
 - To play messages (page 62).
- 6 [MEMO]**
 - To record a memo message (page 62).
- 7 [AUTO ANSWER]**
 - To turn the auto answer setting ON/OFF (page 52).
- 8 [COPY]**
 - To copy a document (page 59).
- 9 [FAX/START][SET]**
 - To start sending or receiving a fax.
 - To store a setting during programming.
- 10 [STOP]**
 - To stop an operation or programming session.
 - To erase a character/number (page 27). Press and hold to erase all characters/numbers.
- 11 [HELP]**
 - To print helpful information for quick reference (page 23).
- 12 [MENU]**
 - To initiate or exit programming.
- 13 [GREETING/REC]**
 - To record a greeting message (page 61).
- 14 [NAVIGATOR][VOLUME]**
 - To adjust volume (page 24).
 - To search for a stored item (page 34, 50).
 - To select features or feature settings during programming (page 66).
 - To navigate to the next operation.
- 15 [GREETING/CHECK]**
 - To check a greeting message (page 61).
- 16 [DIGITAL SP-PHONE]**
 - For speakerphone operation (page 30).
- 17 [RECALL]**
 - To access special telephone services or for transferring extension calls.
- 18 [REDIAL][PAUSE]**
 - To redial the last number dialled from the base unit.
 - To insert a pause during dialling.
- 19 [MUTE]**
 - To mute your voice to the other party during a conversation. Press again to resume the conversation.

current page, scroll up or down by pressing the navigator key, [▲] or [▼], respectively.

1.4 Button descriptions of the handset

- Keep the front cover page open for button locations.
- 1** [☰/OK] (Menu/OK)
 - To initiate programming.
 - To store a setting during programming.
 - To lock/unlock the handset buttons (page 30).
- 2** [☐] (Phonebook)
 - To access the phonebook (page 31).
- 3** [↶] (Talk)
 - To make/answer calls (page 29, 31).
- 4** Navigator
 - To adjust volume (page 24).
 - To search for a stored item (page 32).
 - To select features or feature settings during programming.
 - To navigate to the next operation.
- 5** [☎] (Speakerphone)
 - For speakerphone operation (page 29).
- 6** [R] (Recall)
 - To access special telephone services or for transferring extension calls.
- 7** [☎] (Redial/Pause)
 - To redial one of the last 10 numbers dialled from the handset (page 29).
 - To insert a pause during dialling.
- 8** [⏻] (Off/Power)
 - To turn power ON/OFF (page 23).
 - To hang up (page 29, 31).
 - To stop an operation or programming session.
 - To exit programming.
- 9** [C/☒] (Clear/Mute)
 - To erase a character/number (page 32). Press and hold to erase all characters/numbers.
 - To mute your voice to the other party during a conversation. Press again to resume the conversation.
- 10** [INT] (Intercom)
 - To page or locate another handset (page 83).
- 11** Microphone
 - The built-in microphone.







Note:

- Up to 3 menu items can be displayed at a time. To select a menu item not shown on the

1.5 Display descriptions of the handset

Display icons

Various icons appear on the handset display to indicate the current status of the unit.

Display icon	Meaning
	Within range of a base unit <ul style="list-style-type: none">When flashing: Handset is searching for base unit (out of range of base unit, handset is not registered to base unit, no power on base unit)
	Handset is on an outside call
	Call bar is ON (page 77)
	Battery strength (page 22)
“ [VE] ”	Voice enhancer is set to high or low tone (page 29)
“ [N] ”	Night mode is ON (page 75)
“ [X] ”	Key lock is ON (page 30)
“ [2] ”	Handset number: The left icon shows handset 2 example (page 76)
“-2-”	Base unit number: The left icon shows base unit 2 example (page 76)
	New SMS message received (SMS users only, page 43) (KX-FC235AL only)
	New call minder message received (call minder users only; page 40) (KX-FC231NZ only)
[IN USE]	Line is being used by another handset

1.6 Overview

1.6.1 Base unit

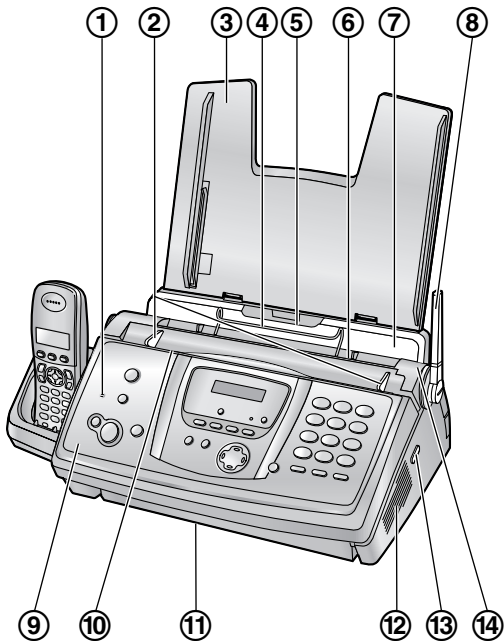

- ① Microphone
- ② Document guides
- ③ Paper tray
- ④ Metal recording paper guide
- ⑤ Recording paper entrance
- ⑥ Recording paper exit
- ⑦ Tension plate
- ⑧ Antenna
- ⑨ Front cover
- ⑩ Document entrance
- ⑪ Document exit
- ⑫ Speaker
- ⑬ Green button (Back cover release button)
- ⑭ Back cover

1.6.2 Handset

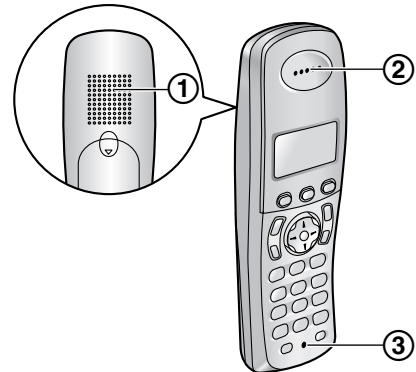

- ① Speaker
- ② Receiver
- ③ Microphone

Removing the shipping tape

Open the front cover by pulling up the centre part (①), then remove the shipping tape (②).

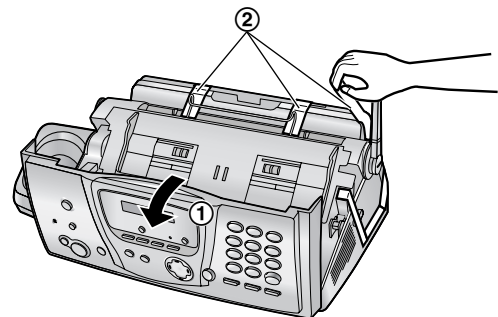

2.1 Ink film installation / replacement

The included film roll is a starter ink film.

Important:

- Remove all blue shipping tape from the unit before installation.

2.1.1 Installing the ink film

The included film roll is a starter ink film.

- 1 Open the front cover by pulling up the centre part.

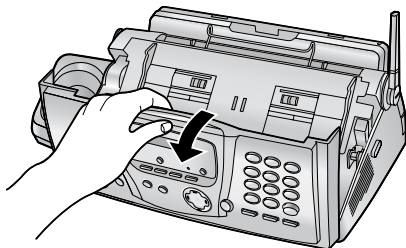

- 2 Release the back cover by pushing the green button (1).

- You can also release the back cover by pushing in the green lever (2).

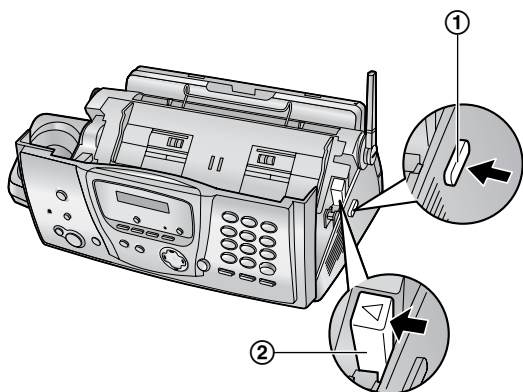

- 3 Open the back cover.

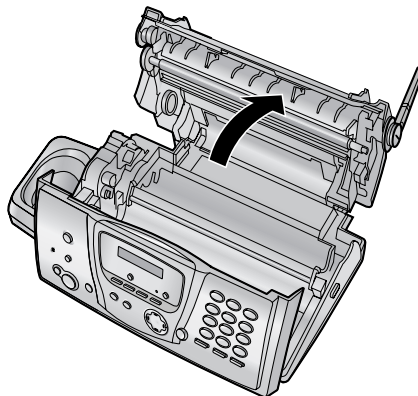

- 4 Insert the front ink film roll by inserting its blue gear into the left slot of the unit (1). Insert the rear ink film roll by inserting its white gear into the left slot of the unit (2).
 - The ink film is safe to touch and will not rub off on your hands like carbon paper.
 - Make sure the blue gear (1) and white gear (2) are installed as shown.

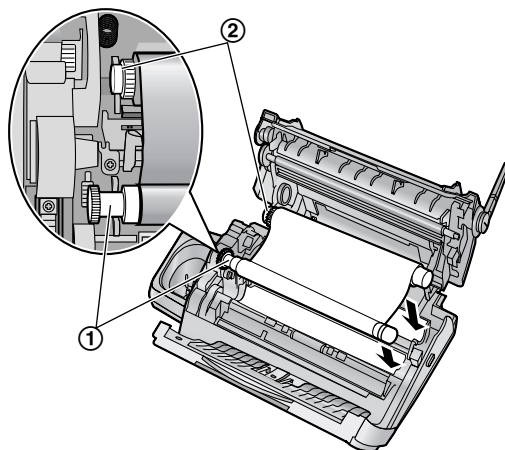

- 5 Turn the gear of the blue core (①) in the direction of the arrow until the ink film is tight (②).

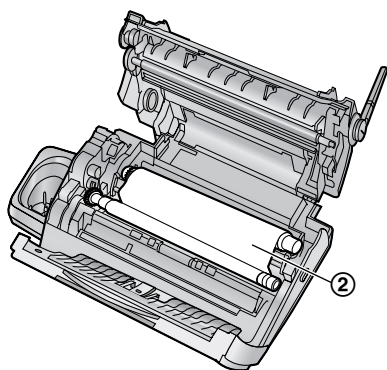
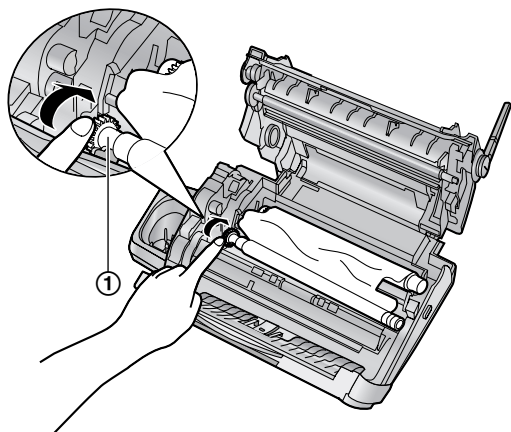

Correct

- The ink film is wrapped around the blue core (③) at least once.

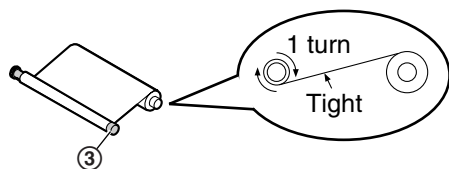

Incorrect

- The ink film is not wrapped around the blue core (④).

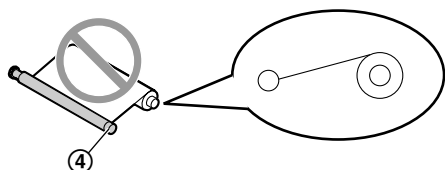

- The ink film is reversed.

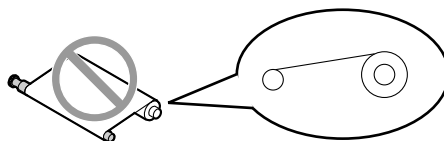

- The ink film is slack or creased.



- 6 Close the back cover securely by pushing down on the notched area at both ends (①).

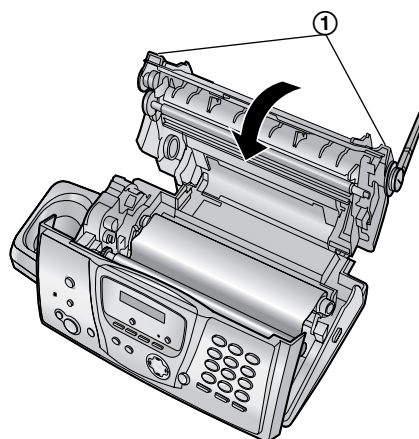

- 7 Close the front cover securely.

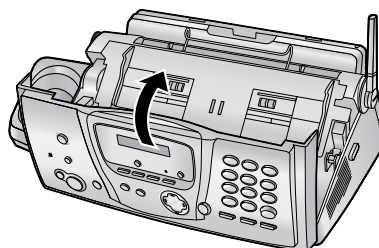

2. Installation

2.1.2 Replacing the ink film

To ensure that the unit operates properly, we recommend the use of Panasonic replacement film. See page 11 for accessory information.

- We cannot be responsible for any damage to the unit or degradation of print quality which may occur from the use of non-Panasonic replacement film.
- 1 Open the covers (see steps 1 to 3 on page 16).
 - 2 Remove the used core (①) and used ink film (②).

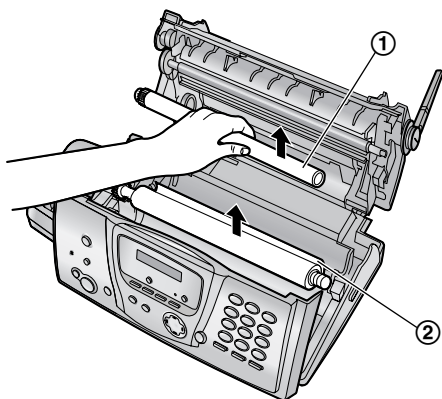

- 3 Remove the stoppers (①) and tags (②) from the new ink film (③).

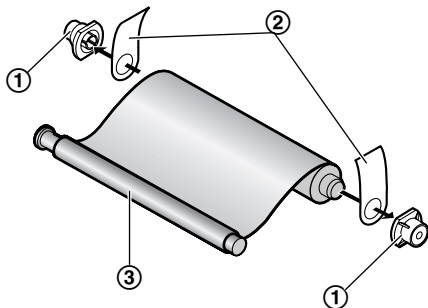

- 4 Insert the ink film and close the covers (see steps 4 to 7 on page 16).

2.2 Paper tray

Insert the tabs on the paper tray (①) into the slots on the back of the unit (②).

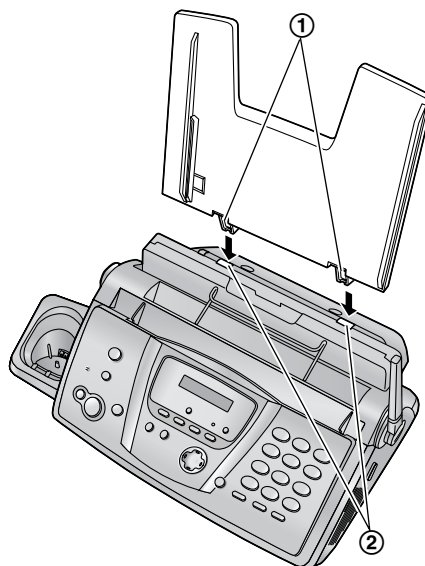

2.3 Recording paper

The unit can hold up to 30 sheets of 80 g/m² paper.

Please refer to page 106 for information on recording paper.

1 Pull the tension plate forward (①).



2 Fan the paper to prevent paper jams.

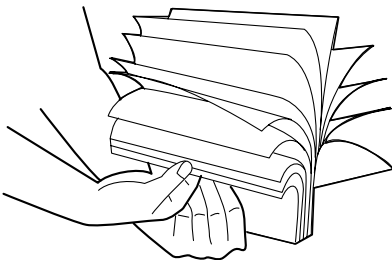

3 Insert the paper, print-side down (①).



4 Push the tension plate back (①).



- If the paper is not inserted correctly, readjust the paper, or the paper may jam.

Correct

Incorrect

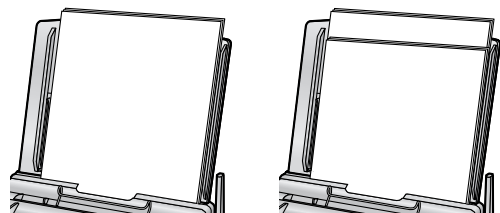

2.4 Battery installation / replacement

2.4.1 Installing the batteries

- 1 Insert the batteries negative (⊖) terminal first.

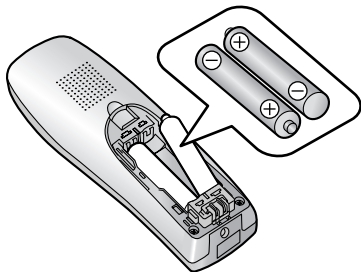

- 2 Close the handset cover.

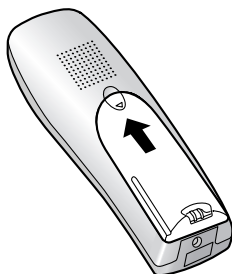
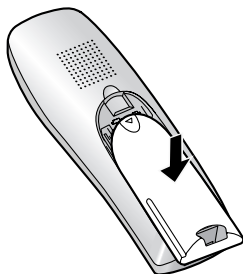

2.4.2 Replacing the batteries

If  flashes even after the handset batteries have been charged for 7 hours, the batteries must be replaced. **We recommend the use of Panasonic batteries.** See page 11 for accessory information.

Important:

- Use only rechargeable batteries. If you install non-rechargeable batteries and start charging, the batteries may leak electrolyte and damage the phone.
- Do not mix old and new batteries.

- 1 Press the notch on the handset cover firmly and slide it in the direction of the arrow.

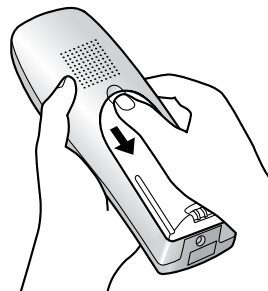

- 2 Remove the old batteries positive (⊕) terminal first and install the new ones. See the battery installation procedure.

3.1 Connections

Important:

- The unit will not function when there is a power failure. To make calls in emergency situations, you should connect a telephone that can function during a power failure to the telephone line.
- ① Power cord
 - Connect to the power outlet (220 V – 240 V, 50/60 Hz).
 - ② Telephone line cord
 - Connect to a single telephone line jack.

- If you use the unit with a computer and your internet provider instructs you to install a filter, please connect the telephone line cord as follows (page 91, 92).

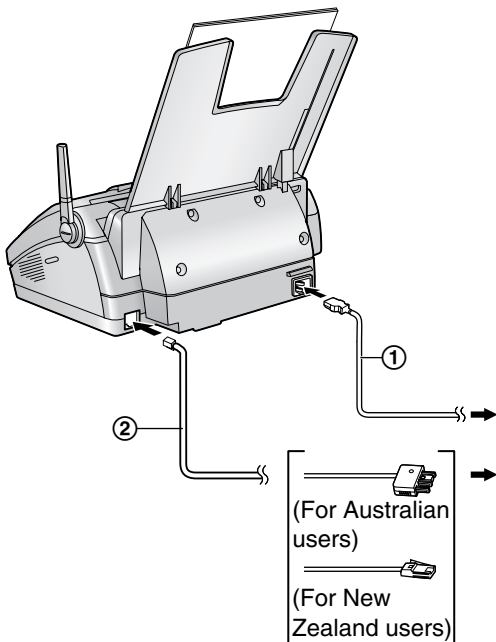
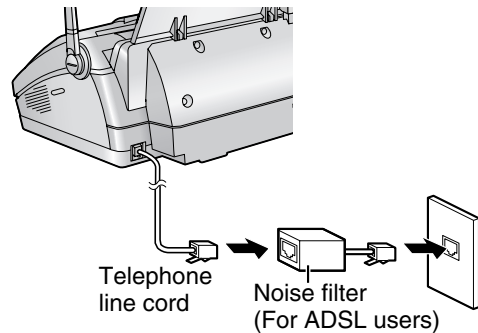

Caution:

- After connection, you must charge the batteries to make or answer calls with the handset (page 22).
- When you operate this product, the power outlet should be near the product and easily accessible.
- Be sure to use the telephone line cord included in this unit.
- Do not extend the telephone line cord.
- This unit is not designed to be used with rotary (pulse dialling) services.

Note:

- If any other device is connected to the same telephone line, this unit may disturb the network condition of the device.

3. Preparation

3.2 Battery charge

Place the handset on the cradle of the base unit for about 7 hours before initial use.

When charging, the battery icon is shown as follows.



When the batteries are fully charged,  remains on the display.

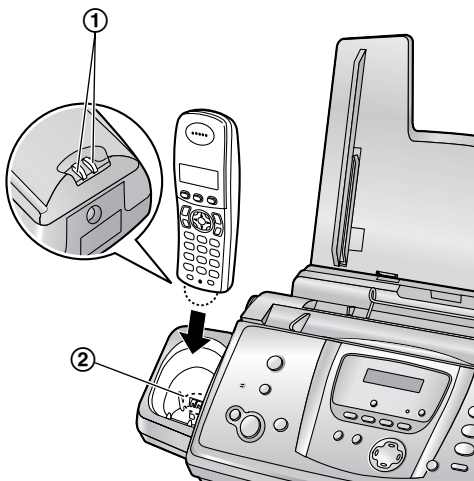



Note:

- Clean the handset charge contacts (①) and the charger charge contacts (②) with a soft, dry cloth once a month, otherwise the batteries may not charge properly. Clean more often if the unit is exposed to grease, dust or high humidity.

Battery strength

You can confirm the battery strength on the handset display.

Battery icons	Battery strength
	High
	Medium
	Low <ul style="list-style-type: none">• When flashing: Needs to be charged

Note:

- If the handset is turned OFF, it will be turned ON automatically when it is placed on the base unit.

- If  flashes when you lift the handset off the base unit, charge the batteries at least 15 minutes.

Battery life

After your Panasonic batteries are fully charged, you can expect approximately the following performance:

Ni-MH Batteries (typical 700 mAh)

Operation	Operating Time
While in use (talking)	20 hours approx.
While not in use (standby)	170 hours approx.

Note:

- Actual battery performance depends on a combination of how often the handset is in use (talking) and how often it is not in use (standby).
- Battery operating time may be shortened over time depending on usage conditions and ambient temperature.

3.3 Turning the handset power ON/OFF

3.3.1 Power ON

Press [***0**] for about 1 second.

- The display will change to the standby mode.

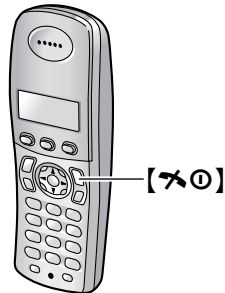

3.3.2 Power OFF

Press [***0**] for about 2 seconds.

- The display will go blank.

3.4 Base unit help function

The unit contains helpful information which can be printed for quick reference.

“**BASIC SETTINGS**”:

How to set the date, time, your logo and fax number.

“**FEATURE LIST**”:

How to program the features.

“**PHONEBOOK**”:

How to store names and numbers in the base unit phonebook and how to dial them.

“**TAM OPERATION**”:

How to use the telephone answering machine.

“**FAX RECEIVING**”:

How to set the base unit to receive faxes.

“**COPIER**”:

How to use the copier function.

“**REPORTS**”:

List of available reports.

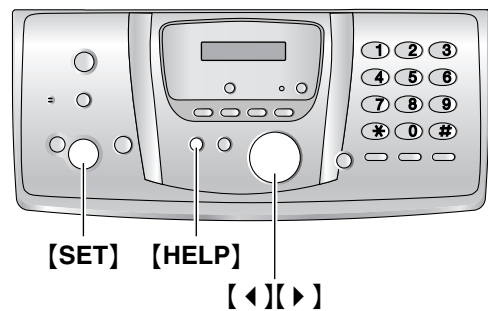

- 1 Press [**HELP**].
- 2 Press [**◀**] or [**▶**] repeatedly to display the desired item.
- 3 Press [**SET**].
 - The selected item will be printed.

3.5 Adjusting handset volume

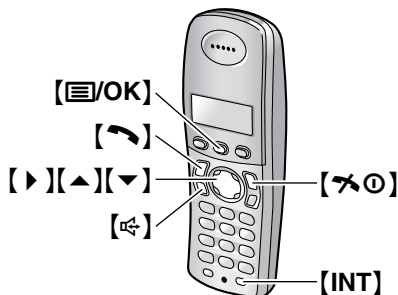

Ringer volume

1. Press [M/OK].
2. Select "Handset Setup", then press [Right Arrow].
3. Select "Ringer Setup", then press [Right Arrow].
4. Select "Ringer Volume", then press [Right Arrow].
5. Press [Up Arrow] or [Down Arrow] repeatedly to select the desired volume.
6. Press [Right Arrow].
7. Press [Power].

Note:

- Alarms will sound and the handset will ring for intercom calls and when paged even if the ringer is turned OFF.

Ring tone

You can select one of 15 ring tones for outside calls and intercom calls (page 75). Caller ID service users can also use a different ringer for each category (page 36).

Receiver volume

While using [Call] or [INT], press [Up Arrow] or [Down Arrow].

Speaker volume

While using [Mute], press [Up Arrow] or [Down Arrow].

3.6 Adjusting base unit volume

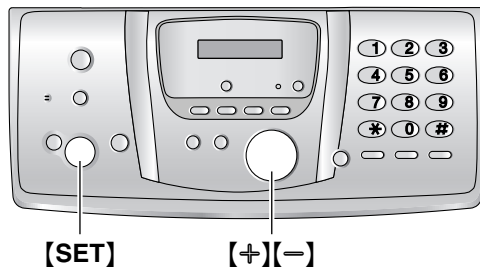

Ringer volume

While the unit is idle, press [+] or [-].

- If any documents are in the document entrance, you cannot adjust the volume. Confirm that there are no documents in the entrance.

To turn the ringer OFF

1. Press [-] repeatedly to display "RINGER OFF= OK?".
2. Press [SET].
 - When a call is received, the base unit will not ring and will display "INCOMING CALL".
 - To turn the ringer back ON, press [+].

Ring tone

You can select the ring tones from one of 3 tones for outside calls (feature #17 on page 67).

Speaker volume

While using the speakerphone, press [+] or [-].

Answering machine volume

While listening to messages, press [+] or [-].

3.7 Date and time

You must set the date and time for both the handset and the base unit.

Times are set independently and may not necessarily be identical.

- The other party's fax machine will print the date and time on each page you send according to your base unit's date and time setting.
- The accuracy of the clock is approximately ± 60 seconds a month.

3.7.1 With the handset

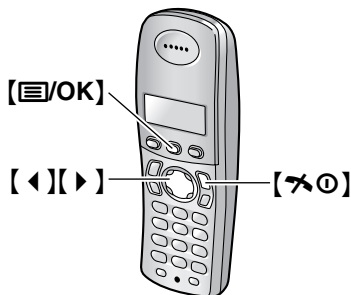

Important:

- Confirm that the power cord of the base unit is connected.
- Ensure that ∇ is not flashing.
- If a power failure occurs, set the date and time for the handset again.

- 1 Press [OK].
- 2 Select "Handset Setup", then press [▶].
- 3 Select "Time Settings", then press [▶].
- 4 Select "Set Date & Time", then press [▶].
 - The cursor (■) will appear on the display.
- 5 Enter the current date/month/year by selecting 2 digits for each.

Example: 10 August, 2005
Press [1][0] [0][8] [0][5].

Date	:10-08-05
Time	:00:00
	*=12/24
∇	

- 6 Enter the current hour/minute by selecting 2 digits for each. Press [*] repeatedly to select "AM", "PM", or 24-hour time entry.

Example: 3:15 PM (12-hour time entry)

1. Press [0][3] [1][5].

Date	:10-08-05
Time	:03:15
	*=12/24
∇	

2. Press [*] repeatedly to display "PM".

Date	:10-08-05
Time	:03:15 PM
	*=12/24
∇	

- 7 Press [OK].

- 8 Press [*].

To correct a mistake

Press [◀] or [▶] to move the cursor to the incorrect number, and make the correction.

Note:

- The date and time on the handset will be lost after a power failure and must be reset, but the base unit has backup to keep the time.

3. Preparation

3.7.2 With the base unit

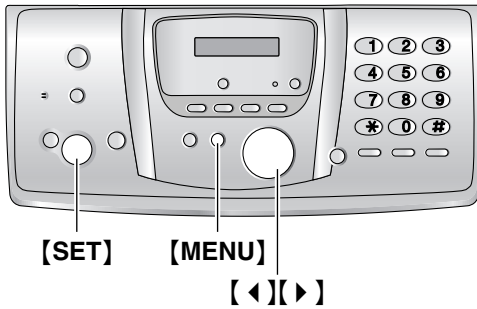

- 1 Press **[MENU]**.

SYSTEM SETUP
PRESS NAVI. [◀ ▶]

- 2 Press **[◀]** or **[▶]** repeatedly to display the following.

SET DATE & TIME
PRESS SET

- 3 Press **[SET]**.

- The cursor (■) will appear on the display.

D:01/M:01/Y:05
TIME: 00:00

- 4 Enter the current date/month/year by selecting 2 digits for each.

Example: 10 August, 2005

Press **[1][0][0][8][0][5]**.

D:10/M:08/Y:05
TIME: 00:00

- 5 Enter the current hour/minute by selecting 2 digits for each. Press **[*]** repeatedly to select "AM", "PM", or 24-hour time entry.

Example: 3:15PM (12-hour time entry)

1. Press **[0][3][1][5]**.

D:10/M:08/Y:05
TIME: 03:15

2. Press **[*]** repeatedly to display "PM".

D:10/M:08/Y:05
TIME: 03:15PM

- 6 Press **[SET]**.

- The next feature will be displayed.

- 7 Press **[MENU]**.

To correct a mistake

Press **[◀]** or **[▶]** to move the cursor to the incorrect number, and make the correction.

3.8 Your logo

Your logo will be printed on the top of each page sent from your unit.

The logo can be your name or the name of your company.

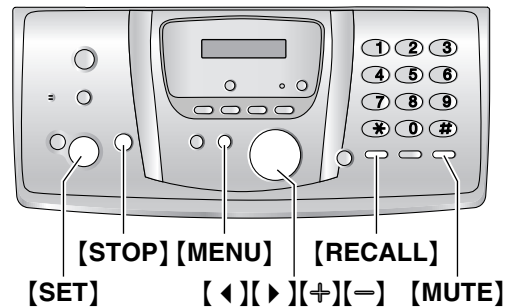

- 1 Press **[MENU]**.

SYSTEM SETUP
PRESS NAVI. [◀ ▶]

- 2 Press **[◀]** or **[▶]** repeatedly to display the following.

YOUR LOGO
PRESS SET

- 3 Press **[SET]**.

- The cursor (■) will appear on the display.

LOGO=■

- 4 Enter your logo, up to 30 characters. See the following character table for details.

- 5 Press **[SET]**.

- The next feature will be displayed.

- 6 Press **[MENU]**.

To select characters with the base unit dial keypad

Keypad	Characters
[1]	Space # & ' () * , - . / 1
[2]	A B C 2 a b c 2
[3]	D E F 3 d e f 3

Keypad	Characters
[4]	G H I 4
	g h i 4
[5]	J K L 5
	j k l 5
[6]	M N O 6
	m n o 6
[7]	P Q R S 7
	p q r s 7
[8]	T U V 8
	t u v 8
[9]	W X Y Z 9
	w x y z 9
[0]	Space 0
[*]	To change uppercase or lowercase letter.
[RECALL]	To enter a hyphen.
[MUTE]	To insert a space.
[STOP]	To delete a digit.

Note:

- To enter another character that is located on the same dial key, press [▶] to move the cursor to the next space.

To enter your logo

Example: "BILL"

- Press [2] 2 times.

LOGO=B

- Press [4] 3 times.

LOGO=BI

- Press [5] 3 times.

LOGO=BIL

- Press [▶] to move the cursor to the next space and press [5] 3 times.

LOGO=BILL

To change uppercase or lowercase letters

Pressing the [*] button will change to uppercase or lowercase letters alternately.

- Press [2] 2 times.

LOGO=B

- Press [4] 3 times.

LOGO=BI

- Press [*].

LOGO=Bi

- Press [5] 3 times.

LOGO=BiL

To correct a mistake

Press [◀] or [▶] to move the cursor to the incorrect character, and make the correction.

To delete a character

Press [◀] or [▶] to move the cursor to the character you want to delete and press [STOP].

- To erase all characters, press and hold [STOP].

To insert a character

- Press [◀] or [▶] to move the cursor to the position to the right of where you want to insert the character.
- Press [MUTE] to insert a space and enter the character.

To select characters using [+] or [-]

Instead of pressing the dial keys, you can select characters using [+] or [-].

- Press [-] repeatedly to display the desired character. Characters will be displayed in the following order:
 - ① Uppercase letters
 - ② Number
 - ③ Symbol
 - ④ Lowercase letters
 - If you press [+], the order will be reversed.
- Press [▶] to insert the character.
- Return to step 1 to enter the next character.

3. Preparation

3.9 Your fax number

Your fax number will be printed on the top of each page sent from your unit.

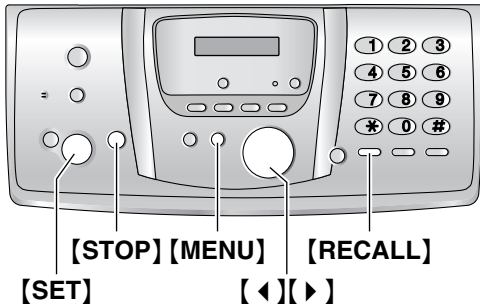

To delete a number

Press [◀] or [▶] to move the cursor to the number you want to delete and press [STOP].

- To erase all numbers, press and hold [STOP].

- 1 Press [MENU].

```
SYSTEM SETUP
PRESS NAVI. [◀ ▶]
```

- 2 Press [◀] or [▶] repeatedly to display the following.

```
YOUR FAX NO.
PRESS SET
```

- 3 Press [SET].
 - The cursor (■) will appear on the display.

```
NO. = ■
```

- 4 Enter your fax number, up to 20 digits.

Example: NO. =1234567■

- 5 Press [SET].
 - The next feature will be displayed.

- 6 Press [MENU].

Note:

- The [*] button enters a "+" and the [#] button enters a space.
Example: +64 9 1234567
Press [*][6][4][#][9][#][1][2][3][4][5][6][7].
- To enter a hyphen in a telephone number, press [RECALL].

To correct a mistake

Press [◀] or [▶] to move the cursor to the incorrect number, and make the correction.

4.1 Making phone calls

4.1.1 With the handset

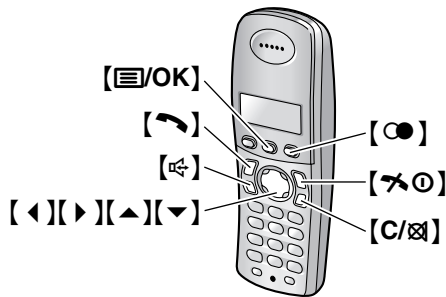

- 1 Lift the handset and press [Call] or [Mute].
- 2 Dial the telephone number.
- 3 When finished talking, press [End Call] or place the handset on the base unit.

Speakerphone operation

For best performance, please note the following:

- Use the speakerphone in a quiet environment.
- Speak alternately with the caller.
- If you or the other party have difficulty hearing each other, press [Up Arrow] or [Down Arrow] repeatedly to adjust the speaker volume as necessary.

To redial the last number dialed from the handset

Press [Call] or [Mute], then press [Redial].

To redial automatically

Press [Mute], then press [Redial].

- If the line is busy, the unit will automatically redial the number up to 9 times. While the handset is waiting to redial, [Mute] will flash. While the handset is redialling, mute is automatically turned ON.

Note:

- If mute does not turn OFF after the line is connected, press [C/ⓧ].

To make a call using the redial list

The last 10 telephone numbers dialed from the handset are stored in the redial list.

1. Press [Redial].
 - The last number dialed will be displayed.
2. Press [Up Arrow] or [Down Arrow] repeatedly to select the desired number.

- To exit the list, press [End Call].

3. Press [Call] or [Mute].
 - If [Mute] is pressed, the unit will redial automatically if the other party's line is engaged.

To edit a number in the redial list before calling it

1. Press [Redial].
2. Press [Up Arrow] or [Down Arrow] repeatedly to select the desired number, then press [M/OK].
3. Select "Edit and Call", then press [Right Arrow].
4. Press [Left Arrow] or [Right Arrow] to move the cursor, then edit the number.
 - Place the cursor on the number you wish to erase, then press [C/ⓧ].
 - Place the cursor to the right of where you want to insert a number, then make the correction.
5. Press [Call] or [Mute].

To erase numbers in the redial list

1. Press [Redial].
2. Press [Up Arrow] or [Down Arrow] repeatedly to select the desired number, then press [M/OK].
3. Select "Erase", then press [Right Arrow].
 - If you want to erase all numbers in the list, select "Erase All", then press [Right Arrow].
4. Select "Yes", then press [Right Arrow].
5. Press [End Call].

To store a number from the redial list into the handset phonebook

1. Press [Redial].
2. Press [Up Arrow] or [Down Arrow] repeatedly to select the desired number, then press [M/OK].
3. Select "Add Phonebook", then press [Right Arrow].
4. Enter a name, up to 16 characters (see page 85 for character entry), then press [M/OK].
5. Edit the phone number if necessary, then press [M/OK].
6. Select the desired category (page 32), then press [Right Arrow].
7. Select "Save", then press [Right Arrow].
8. Press [End Call].

Voice enhancer

You can change the tone quality of the receiver while you are on a call. 3 settings are available.

1. Press [M/OK] during a call.

4. Telephone

2. Select “**Voice Enhancer**”, then press [▶].

3. Select the desired setting, then press [▶].

Note:

- If you select “**High Tone**” or “**Low Tone**”, “[VE]” is displayed.

Mute

You can mute your voice during a conversation. While mute is turned ON, you will be able to hear the other party, but the other party will not be able to hear you.

1. To mute your voice, press [C/⊗].
2. To return to the conversation, press [C/⊗] again.

Key lock

The handset can be locked so that no calls or settings can be made. Incoming calls can be answered, but all other functions are disabled while key lock is ON. Emergency calls (page 79) cannot be made until key lock is turned OFF.

To turn key lock ON, press [≡/OK] for about 2 seconds.

- “[x]” is displayed.

To turn key lock OFF, press [≡/OK] for about 2 seconds.

Note:

- Key lock is turned OFF when the handset is turned OFF.

4.1.2 With the base unit

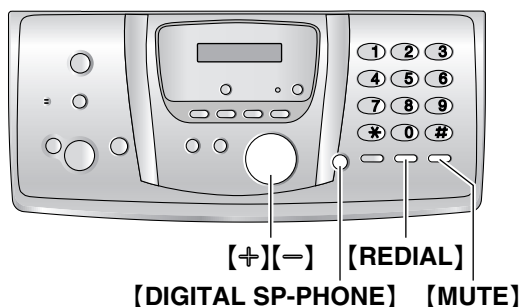

- 1 Press [DIGITAL SP-PHONE].
- 2 Dial the telephone number.
- 3 When finished talking, press [DIGITAL SP-PHONE].

Speakerphone operation

For best performance, please note the following:

- Use the speakerphone in a quiet environment.
- Speak alternately with the caller.

- If you or the other party have difficulty hearing each other, press [+] or [-] repeatedly to adjust the speaker volume as necessary.

To redial the last number dialed from the base unit

Press [DIGITAL SP-PHONE], then press [RECALL].

To redial automatically

Press [DIGITAL SP-PHONE], then press [RECALL].

- If the line is busy, the unit will automatically redial the number up to 9 times. While the base unit is redialling, mute is automatically turned ON.

Note:

- If mute does not turn OFF after the line is connected, press [MUTE].

4.2 Answering phone calls

4.2.1 With the handset

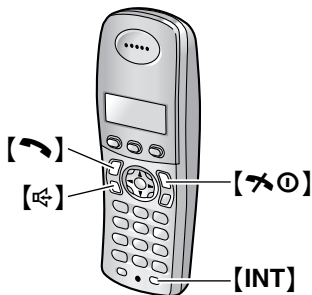

- Lift the handset and press [hook] or [hook with speaker].
 - You can also answer a call by pressing any dial key from [0] to [9], [*], [#] or [INT]. (Any key answer feature)
- When finished talking, press [hook with handset] or place the handset on the base unit.

Auto talk feature

You can answer calls simply by lifting the handset off the base unit. You do not need to press [hook]. To turn this feature ON, see page 77.

4.2.2 With the base unit

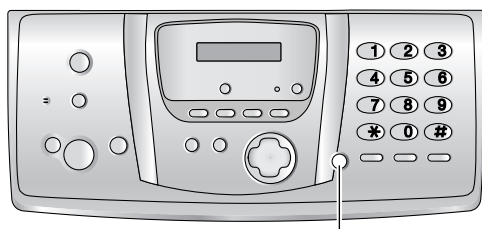

[DIGITAL SP-PHONE]

- Press [DIGITAL SP-PHONE].
- When finished talking, press [DIGITAL SP-PHONE].

4.3 Handset phonebook

The handset phonebook allows you to make calls without having to dial manually. You can add 200 names and phone numbers to the phonebook, assign each phonebook item to the desired category, and search for phonebook items by name or category.

When the system has additional handsets (page 81), each handset can have its own phonebook. You can copy phonebook items between two handsets (page 84).

- The base unit has its own individual phonebook (page 34).

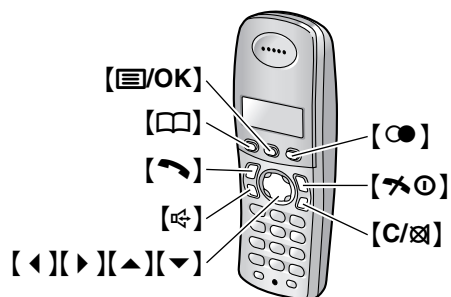

4.3.1 Storing phonebook items

- Press [list/OK], then press [list/OK].
- Select "New Entry", then press [right].
- Enter the name, up to 16 characters (see page 85 for character entry), then press [list/OK].
- Enter the telephone number, up to 24 digits, then press [list/OK].
- Select the desired category for the item, then select [right].
 - Caller ID service users can use additional private category features (page 36).
 - You can search for handset phonebook items by category (page 32).
 - You can change the category names (page 32).
- Select "save", then press [right].
 - To program other items, repeat steps 3 to 6.
- Press [hook with handset].

Note:

- If there is no space to store new items, "Memory Full" will be displayed. Erase unnecessary items (page 33).

4. Telephone

To correct a mistake

1. Press [◀] or [▶] to move the cursor to the incorrect character/number.
2. Press [C/⊗].
 - To erase all characters/numbers, press and hold [C/⊗].
3. Enter the correct character/number.

4.3.2 Categories

Categories can help you find items in the handset phonebook quickly and easily. When adding an item to the handset phonebook you can assign it to the desired category. You can change the names of categories assigned for handset phonebook items (“Friends”, “Family”, etc.) and then search for phonebook items by category. Additional category features are available for Caller ID users (page 36).

To change category names

1. Press [□□], then press [≡/OK].
2. Select “Category”, then press [▶].
3. Select the category you want to change the name of, then press [▶].
4. Select “Category Name”, then press [▶].
5. Edit the name, up to 10 characters (see page 85 for character entry), then press [≡/OK].
6. Press [↶⓪].

4.3.3 Making a phone call using the phonebook

Before using this feature, store the desired names and telephone numbers in the handset phonebook (page 31).

- 1 Press [□□].
- 2 Press [▲] or [▼] repeatedly to display the desired item.
 - To search by first character (index search), see page 32. To search by category, see page 32.
- 3 Press [↶] or [☎].
 - The handset will start dialling automatically.

To search for a name by first character (index search)

1. Press [□□], then press [●].
2. Select “Index Search”, then press [▶].

3. Select the character entry mode that contains the character you are searching for, and press [▶].
4. Press the dial key ([0] to [9]) which contains the character you are searching for (page 85).
 - Press the same dial key repeatedly to display the first item corresponding to each letter located on that dial key.
 - If there is no item corresponding to the letter you selected, the next item will be displayed.
5. Press [▼] repeatedly to display the desired item.

To search for a name by category

1. Press [□□], then press [●].
2. Select “Category Search”, then press [▶].
3. Select the category you want to search, then press [▶].
 - The first item in that category is displayed.
 - If you select “All”, the unit will end the category search.
4. Press [▼] repeatedly to display the desired item.

4.3.4 Editing a stored item

- 1 Press [□□].
- 2 Press [▲] or [▼] repeatedly to display the desired item.
 - To search by first character (index search), see page 32. To search by category, see page 32.
- 3 Press [≡/OK].
- 4 Select “Edit”, then press [▶].
 - If you do not need to edit the name, skip to step 6.
- 5 Edit the name. For further details, see the storing procedure on page 31.
- 6 Press [≡/OK].
 - If you do not need to edit the telephone number, skip to step 8.
- 7 Edit the telephone number. For further details, see the storing procedure on page 31.
- 8 Press [≡/OK].
- 9 Select the desired category for the item, then press [▶].

- 10 Select “Save”, then press [▶].
- To edit other items, repeat steps 2 to 10.

11 Press [✕].

4.3.5 Erasing stored items

To erase an item

- 1 Press [□].
- 2 Press [▲] or [▼] repeatedly to display the desired item.
 - To search by first character (index search), see page 32. To search by category, see page 32.
- 3 Press [≡/OK].
- 4 Select “Erase”, then press [▶].
- 5 Select “Yes”.
 - To cancel erasing, press [✕].
- 6 Press [▶].
- 7 Press [✕].

To erase all items

- 1 Press [□], then press [≡/OK].
- 2 Select “Erase All”, then press [▶].
- 3 Select “Yes”, then press [▶].
- 4 Select “Yes” again, then press [▶].
- 5 Press [✕].

4.3.6 One touch dial

Handset dial keys [1] to [9] can each be used as a one touch dial, allowing you to dial a number from the handset phonebook by simply pressing a dial key.

To assign an item to a one touch dial key

1. Press [□].
2. Press [▲] or [▼] repeatedly to select the desired item.
 - To search by first character (index search), see page 32. To search by category, see page 32.
3. Press [≡/OK].
4. Select “One Touch Dial”, then press [▶].
5. Press [▲] or [▼] to select the desired dial key number, then press [▶].
 - When the dial key is already used as a one touch dial key, “*” is displayed next to the dial key number. If you select this dial key, “Overwrite” is displayed. You can overwrite the previous assignment if necessary.

- If you do not wish to overwrite, select “Go Back”.

6. Select “Save”, then press [▶].

7. Press [✕].

To make a call using a one touch dial key

1. Press and hold the desired one touch dial key ([1] to [9]).
 - You can view other one touch dial assignments by pressing [▲] or [▼].
2. Press [↶] or [↷].

To erase a one touch dial assignment

1. Press and hold the desired one touch dial key ([1] to [9]).
2. Press [≡/OK], then press [▶].
3. Select “Yes”, then press [▶].

Note:

- The number erased from a one touch dial key will not be deleted from the phonebook. To erase from the phonebook, see page 33.

4.3.7 Chain dial

This feature allows you to dial phone numbers in the handset phonebook while you are on a call. This feature can be used, for example, to dial a calling card access number or bank account PIN that you have stored in the handset phonebook, without having to dial manually.

- 1 During a phone call, press [□].
- 2 Press [▲] or [▼] repeatedly to select the desired item.
 - To search by first character (index search), see page 32. To search by category, see page 32.
- 3 Press [▶] to dial the number.

4.4 Base unit phonebook

The base unit phonebook allows you to make calls without having to dial manually. You can store 100 names and telephone numbers to the phonebook.

- You can also send faxes using the base unit phonebook (page 50).
- The handset has its own individual phonebook (page 31).

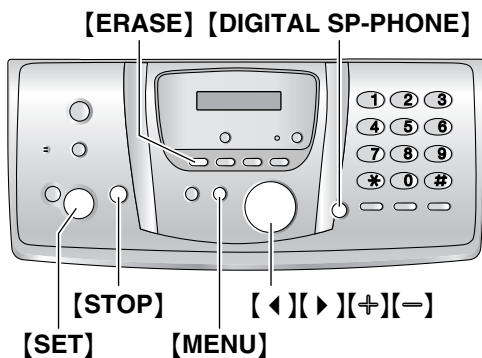

4.4.1 Storing phonebook items

- 1 Press **[MENU]** repeatedly to display "PHONEBOOK SET".
- 2 Press **[*]**.
- 3 Enter the name, up to 16 characters (see page 26 for instructions).
- 4 Press **[SET]**.
- 5 Enter the telephone number, up to 24 digits.
- 6 Press **[SET]**.
 - To program other items, repeat steps 3 to 6.
- 7 Press **[MENU]**.

Helpful hints:

- You can confirm the stored items by printing the fax number list (page 105).

To correct a mistake

Press **[◀]** or **[▶]** to move the cursor to the incorrect character/number, and make the correction.

To delete a character/number

Press **[◀]** or **[▶]** to move the cursor to the character/number you want to delete, and press **[STOP]**.

- To erase all characters/numbers, press and hold **[STOP]**.

4.4.2 Making a phone call using the phonebook

Before using this feature, store the desired names and telephone numbers in the base unit phonebook (page 34).

- 1 Press **[▶]**.
- 2 Press **[⊕]** or **[⊖]** repeatedly to display the desired item.
- 3 Press **[DIGITAL SP-PHONE]**.
 - The base unit will start dialling automatically.

To search for a name by initial

Example: "LISA"

1. Press **[▶]**.
2. Press **[⊕]** or **[⊖]** to initiate the phonebook.
3. Press **[5]** repeatedly to display any name with the initial "L" (see the character table, page 26).
 - To search for symbols, press **[1]**.
4. Press **[⊖]** repeatedly to display "LISA".
 - To stop the search, press **[STOP]**.
 - To dial the displayed party, press **[DIGITAL SP-PHONE]**.

4.4.3 Editing a stored item

- 1 Press **[▶]**.
- 2 Press **[⊕]** or **[⊖]** repeatedly to display the desired item.
- 3 Press **[MENU]**.
- 4 Press **[*]**.
 - If you do not need to edit the name, skip to step 6.
- 5 Edit the name. For further details, see the storing procedure on page 34.
- 6 Press **[SET]**.
 - If you do not need to edit the telephone number, skip to step 8.
- 7 Edit the telephone number. For further details, see the storing procedure on page 34.
- 8 Press **[SET]**.

4.4.4 Erasing a stored item

- 1 Press **[▶]**.

- 2 Press **[+]** or **[-]** repeatedly to display the desired item.
- 3 Press **[MENU]**.
- 4 Press **[#]**.
 - To cancel erasing, press **[STOP]**.
- 5 Press **[SET]**.

Another method to erase a stored item

1. Press **[▶]**.
2. Press **[+]** or **[-]** repeatedly to display the desired item.
3. Press **[ERASE]**.
4. Press **[SET]**.

4.5 Caller ID service

This unit is compatible with Caller ID service offered by your local telephone company. To use this feature, you must subscribe to Caller ID service.

For New Zealand users:

For all local and national incoming calls, your display will show the area code (e.g. 09 for Auckland) or the cellular prefix (e.g. 0274 for Telecom Cellular) followed by the caller's telephone number. An Auckland caller's number will be displayed as 09XXXXXXX. The seven X's represent the seven digits of the caller's telephone number. A caller from a 6-digit Telecom Cellular number will be displayed as 0274XXXXXX. For incoming international calls, your display may only show "0000". For business users on a Centrex line, your display will show Centrex extension numbers in the shorter extension number format used within your company.

- Caller information will not be presented on incoming fax calls if Telecom FaxAbility is used.

4.5.1 How Caller ID is displayed

When an outside call is received, the calling party's telephone number or name will be displayed. You then have the option of whether or not to answer the call.

The unit will automatically store caller information (telephone number, name, date and time of the call) of the last 30 (base unit)/50 (handset) callers. Caller information is stored by the most recent to the oldest call. When the 31st (base unit)/51st (handset) call is received, the oldest call is deleted.

Caller information can be viewed on the display one item at a time (page 37) or confirmed by printing the Caller ID list (page 105).

Note:

- When caller information is received and it matches a telephone number stored in the unit's phonebook:
 - The stored name will be displayed and logged.
 - The handset will use the ring tone assigned to the caller's category.
- If the unit is connected to a PBX (Private Branch Exchange) system, caller information may not be received properly. Consult your PBX supplier.
- If the unit cannot receive caller information, the following will be displayed:

4. Telephone

“**OUT OF AREA**”: The caller dialed from an area which does not provide Caller ID service.

“**PRIVATE CALLER**”: The caller requested not to send caller information.

Note for Australian users:

- Although Telstra and Optus do not currently send caller name information, the caller's name will be displayed as stored in the directory, when a call from that caller is received.
- The area code will need to be stored with the 8-digit telephone number.

Note for New Zealand users:

- Although Telecom New Zealand and TelstraClear do not currently send caller name information, the caller's name will be displayed as stored in the directory, when a call from that caller is received.
- Your telephone company may charge you for a local call if the number dialed has the area code prefix included. If this is unacceptable, dial only the 7-digit local number. Do not dial the **[0]** prefix or the area code.

To confirm caller information by printing the Caller ID list

- To print manually, see page 105.
- To print automatically after every 30 new calls, activate feature #26 (page 68).

Category features for Caller ID subscribers

Categories can help you identify who is calling by using different ring tones for different categories of callers.

When adding an item to the handset phonebook you can assign it to the desired category (page 32). When a call is received from a caller assigned to a category, the category's ring tone you select is used.

Changing category ring tones

You can select a ring tone for each category. If you select “**Ext. Ringtone**”, the unit will use the external ring tone you set on page 75 when calls from this category are received. The default setting is “**Ext. Ringtone**”.

1. Press **[□]**, then press **[≡/OK]**.
2. Select “**Category**”, then press **[▶]**.
3. Select a category, then press **[▶]**.
4. Select the current setting of the category ring tone, then press **[▶]**.
5. Select the desired ring tone, then press **[▶]**.
6. Press **[✕○]**.

4.5.2 Call waiting and Caller ID compatible (Handset only) (KX-FC235AL only)

If you subscribe to Caller ID service, your handset displays the second caller's information while talking. After you hear a call-waiting tone, the caller's phone number will be displayed. You can answer the second call, keeping the first call on hold. Follow Telstra or your service provider instructions using **[R]**.

- If the phone number is stored in the phonebook with its name, the caller's name will also be displayed.
- Please contact Telstra or your service provider for details and availability in your area.

Using Caller ID type II

When you receive a second call during a conversation, you will hear a signal tone following the call waiting tone and the **conversation will be interrupted or muted for a short period of time**. This is not the fault of the product as these events are normal.

Note:

- The tones are generated by the service provider.

4.6 Viewing and calling back using caller information

You can easily view caller information and call back.

Important:

- **Calling back will not be possible if the caller information does not include a telephone number.**

Note:

- Telstra, Optus, Telecom New Zealand and TelstraClear do not currently send caller name information.

4.6.1 With the handset

The display will show the number of new calls in standby mode.

Example:

10 Calls 10 Aug 3:15

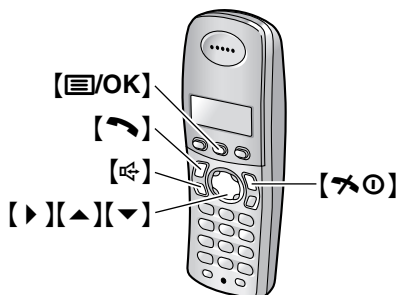

- 1 Press **[OK]**.
- 2 Select "Caller List", then press **[NEXT]**.
 - The most recent call is displayed.
- 3 Press **[PREV]** to search from the most recently received caller information.
 - If you press **[NEXT]**, the display order will be reversed.
 - A ✓ is displayed next to items which have already been viewed or answered, even if they were viewed or answered using another handset.
- 4 Press **[CALL]** or **[MUTE]** to return the call.
 - The handset will start dialling automatically.

To stop viewing

Press **[STOP]** after step 3.

4.6.2 With the base unit

The display will show the number of new calls in standby mode.

Example:	10 CALLS 10:59
----------	-------------------

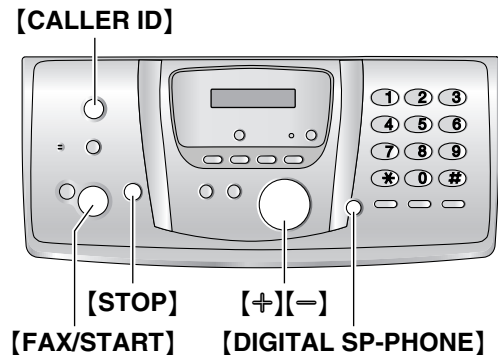

- 1 Press **[CALLER ID]**.
- 2 Press **[PREV]** to search from the most recently received caller information.
 - If you press **[NEXT]**, the display order will be reversed.
- 3 Press **[DIGITAL SP-PHONE]** to return the call.
 - The unit will start dialling automatically.
 - To send a fax, insert the document FACE DOWN and press **[FAX/START]**.

Note:

- If you do not want to dial the area codes when making calls from the Caller ID list, you can store the area codes which you want the unit to delete automatically (page 79).

To change the way caller information is displayed

Press **[CALLER ID]** repeatedly after step 2.

Example:	SAM LEE 20 Jul 11:20 ✓
	↑↓
	3456789012 20 Jul 11:20 ✓

- A ✓ on the display means the item has already been viewed or answered.

Display while viewing

When the unit could not receive a name, the display will show "NO NAME RCVD".

4. Telephone

To stop viewing

Press **[STOP]** after step 2.

4.7 Editing a caller's telephone number before calling back

- Keep the front cover page open for button locations.

Note:

- Telstra, Optus, Telecom New Zealand and TelstraClear do not currently send caller name information.

The caller's telephone number, which is sent to your telephone from your local telephone exchange, includes "0" and an area code prefix. For local calls, "0" and the area code prefix can be omitted (For New Zealand users only).

4.7.1 With the handset

- 1 Press **[≡/OK]**.
- 2 Select "Caller List", then press **[▶]**.
- 3 Press **[▲]** or **[▼]** repeatedly to display the desired item.
- 4 **To add a number**
Press the dial key (**[0]** to **[9]**).
 - The number you pressed is added to the top of the current number.

To erase a number

Press **[≡/OK]**, select "Edit and Call", then press **[▶]**.
Press **[◀]** or **[▶]** to place the cursor on the number you wish to erase, then press **[C/⊗]**.

- 5 Press **[↶]** or **[↷]**.

4.7.2 With the base unit

- 1 Press **[CALLER ID]**.
- 2 Press **[+]** or **[-]** repeatedly to display the desired item.
- 3 Press **[CALLER ID]** repeatedly to display the telephone number.
- 4 To insert a number in front of the telephone number, press the desired dial key (**[0]** to **[9]**).
 - You can also initiate the editing mode by pressing **[*]**.
- 5 Press **[DIGITAL SP-PHONE]** to call back the edited number.

- The unit will start dialling automatically.
- To send a fax, insert the document FACE DOWN and press **[FAX/START]**.

To correct a mistake

1. Press **[◀]** or **[▶]** to move the cursor to the incorrect number.
2. Press **[STOP]** to delete the number.
3. Enter the correct number.

To delete a number

Press **[◀]** or **[▶]** to move the cursor to the number you want to delete and press **[STOP]**.

- To erase all numbers, press and hold **[STOP]**.

To insert a number

1. Press **[◀]** or **[▶]** to move the cursor to the position to the right of where you want to insert the number.
2. Enter the number.

4.8 Erasing caller information

- Keep the front cover page open for button locations.

Note:

- Telstra, Optus, Telecom New Zealand and TelstraClear do not currently send caller name information.

4.8.1 With the handset

- 1 Press **[≡/OK]**.
- 2 Select "Caller List", then press **[▶]**.
- 3 Press **[▲]** or **[▼]** repeatedly to display the desired item, then press **[≡/OK]**.
- 4 Select "Erase", then press **[▶]**.
 - To erase all items, select "Erase All", then press **[▶]**.
- 5 Select "Yes", then press **[▶]**.
- 6 Press **[✕⊙]**.

4.8.2 With the base unit

To erase all caller information

1. Press **[CALLER ID]**.
2. Press **[ERASE]**.
3. Press **[SET]**.
 - To cancel erasing, press **[STOP]**.

To erase specific caller information

1. Press **[CALLER ID]**.
2. Press **[+]** or **[-]** repeatedly to display the desired item.
3. Press **[◀]**.
 - To cancel erasing, press **[STOP]** 2 times.
4. Press **[SET]**.
 - To erase other items, repeat steps 2 to 4.
5. Press **[STOP]**.

Another method to erase a specific caller information

1. Press **[CALLER ID]**.
2. Press **[+]** or **[-]** repeatedly to display the desired item.
3. Press **[ERASE]**.
 - To erase other items repeat steps 2 to 3.
4. Press **[STOP]**.

4.9 Storing caller information into the phonebook

- Keep the front cover page open for button locations.

Important:

- **This feature is not available if the caller information does not include a telephone number.**

Note:

- Telstra, Optus, Telecom New Zealand and TelstraClear do not currently send caller name information.

4.9.1 Into the handset phonebook

- 1 Press **[≡/OK]**.
- 2 Select **"Caller List"**, then press **[▶]**.
- 3 Press **[▲]** or **[▼]** repeatedly to display the desired item, then press **[≡/OK]**.
- 4 Select **"Add Phonebook"**, then press **[▶]**.
- 5 Enter the name, up to 16 characters (see page 85 for character entry), then press **[≡/OK]**.
- 6 Enter the telephone number, up to 24 digits, then press **[≡/OK]**.
- 7 Select the desired category for the item, then select **[▶]**.
- 8 Select **"Save"**, then press **[▶]**.
- 9 Press **[✕⊙]**.

Note:

- To edit a name and number, see page 32.
- If there is no space to store new items, **"Memory Full"** will be displayed. Erase unnecessary items (page 33).

4.9.2 Into the base unit phonebook

- 1 Press **[CALLER ID]**.
- 2 Press **[+]** or **[-]** repeatedly to display the desired item.
- 3 Press **[MENU]**.
- 4 If a name is required, enter up to 16 characters for the name (page 26).

4. Telephone

5 Press **[SET]**.

6 Press **[SET]**.

Note:

- You can confirm the stored items in the base unit phonebook by printing the fax number list (page 105).
- To edit a name and number, see page 34.

4.10 Voice mail service (for Australian users only)

Voice mail is an automatic answering service offered by your service provider. If you subscribe to this service, your service provider's voice mail system can answer calls for you when you are unavailable to answer the phone or when your line is busy. Messages are recorded by the service provider, not your telephone.

Note:

- For more information on using the unit's answering system and your service provider's voice mail service, see page 63.

4.11 Call minder (for New Zealand users only)

Call minder is an automatic answering service offered by your service provider. If you subscribe to this service, your service provider's call minder system can answer calls for you when you are unavailable to answer the phone or when your line is busy.

Messages are recorded by the service provider, not your telephone.

When you have new messages,  will be displayed on the handset.

Please consult your service provider for details of this service.

Note:

- If  still remains on the display even after you have listened to new messages, turn it off by pressing and holding **[C/⊗]** for 2 seconds.

5.1 SMS (Short Message Service)

SMS allows you to send and receive text messages between other fixed-line and mobile phones that support compatible SMS networks and features.

Important:

- **To use SMS features, you must:**
 - **subscribe to the Caller ID and/or appropriate service**
 - **confirm SMS is turned ON for both the handset and the base unit**
 - **confirm the correct message centre numbers are stored**

Consult your service provider for details and availability.

If you have requested that your service provider block your phone number when making phone calls, you will not be able to send SMS messages. In order to send messages, you need to add "1832" to the beginning of the Message Centre 1 number. Note that by doing so, your phone number will be sent along with your SMS messages.

Using public mailbox and private mailboxes

SMS messages can be sent to and received from a public mailbox or any one of the 6 private mailboxes available in this unit. Public mailbox can be accessed freely without password protection. For privacy, private mailboxes are password protected.

Important:

- **To use any of the private mailboxes, you must create private mailboxes (store the name and password; page 45)**

Note:

- A total of 47 messages (at 160 characters/message) in all mailboxes added together can be saved. Total number may be more than 47 if length of messages are less than 160 characters/message.
- If the unit is connected to a PBX system, you may not be able to use SMS features.

5.2 Turning SMS ON/OFF

You must turn SMS ON for both the handset and the base unit.

- Keep the front cover page open for button locations.

5.2.1 With the handset

- 1 Press [☰/OK].
- 2 Select "SMS", then press [▶].
- 3 Select "Public", then press [▶].
- 4 Select "Settings", then press [▶].
- 5 Enter "0000" (default base unit PIN).
 - If you changed the PIN, enter it (page 80).
- 6 Select "SMS On/Off", then press [▶].
- 7 Select "On" or "Off" (default), then press [▶].
- 8 Press [✕⊙].

5.2.2 With the base unit

- 1 Press [MENU].
- 2 Press [≡], then [5][3].
- 3 Press [+] or [–] repeatedly to select "ON" or "OFF" (default).
- 4 Press [SET].
- 5 Press [MENU].

Note:

- If you try to send a message while SMS is turned OFF, a tone sounds and the message is placed in the receive list with "FD" attached to it.
- If someone tries to send you a message while SMS is turned OFF, the message will not be received and the message centre number will be logged in the Caller ID list.

5.3 Changing SMS message centre numbers

SMS message centre telephone numbers must be stored in order to send and receive SMS messages.

The following numbers (used for SMS services provided by Telstra) are preprogrammed in this unit. You can change them if necessary.

- Message Centre 1: 01983391
- Message Centre 2: 01983391

Message Centre 1 is used for sending SMS messages, and Message Centre 2 is used for receiving messages.

- Keep the front cover page open for button locations.

5. SMS (KX-FC235AL only)

- Consult your service provider for more information.
- 1 Press **[≡/OK]**.
 - 2 Select “SMS”, then press **[▶]**.
 - 3 Select “Public”, then press **[▶]**.
 - 4 Select “Settings”, then press **[▶]**.
 - 5 Enter “0000” (default base unit PIN).
 - If you changed the PIN, enter it (page 80).
 - 6 Select “Message Centre1” or “Message Centre2”, then press **[▶]**.
 - 7 Edit the number as necessary, then press **[≡/OK]**.
 - 8 Select “Save”, then press **[▶]**.
 - 9 Press **[✕/0]**.

Note:

- If your phone is connected to a PBX, you need to add the PBX line access number and a dialling pause to the beginning of the Message Centre 1 phone number.

5.4 Sending a message

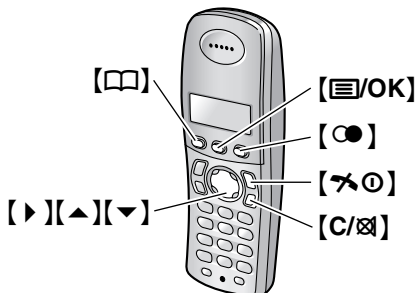

5.4.1 Writing and sending a new message

- 1 Press **[≡/OK]**.
- 2 Select “SMS”, then press **[▶]**.
- 3 **To access the public mailbox**
Select “Public”, then press **[▶]**.
To access a private mailbox
Select the desired mailbox, press **[▶]**, then enter its password.
- 4 Select “Create”, then press **[▶]**.
 - If “▲Use Last Text?” is displayed, you can use the text from the last message you created by pressing **[▲]**. This message will be displayed only if the last

message was created using the same mailbox you selected in step 3.

- 5 Enter the message (page 46), then press **[≡/OK]**.

- 6 Enter the destination telephone number.

Manually:

Enter the number, up to 20 digits.

Using the handset phonebook:

1. Press **[☐]**.
2. Press **[▲]** or **[▼]** repeatedly to display the desired item.
 - You can also find an item using one of the search methods on page 32.
3. Press **[≡/OK]**.

Using the Caller ID list:

1. Press **[▲]** or **[▼]** repeatedly to select the party.
2. Press **[≡/OK]**.

Using the redial list:

1. Press **[☎]** repeatedly to select the telephone number.
2. Press **[≡/OK]**.

- 7 If you wish to send the message to the other party's mailbox, enter the other party's mailbox number after the destination phone number.

Example: The other party's phone number is 123456 and their mailbox number is 1.

Enter 1234561.

- To send the message to the public mailbox, skip to step 8.

- 8 Press **[≡/OK]**.

- 9 To save the message, select “Yes”, then press **[▶]**.
 - To send the message without saving it, select “No”, then press **[▶]**.

- 10 To send the message, select “Send”, then press **[▶]**.
 - To cancel sending, press **[✕/0]**.

Note:

- This unit supports SMS messages of up to 612 characters, however, the maximum number of characters you can send or receive may be limited by your SMS service provider. Consult your SMS service provider for details.
- If your message contains over 160 characters, “**Long Message**” is displayed. Your service provider may treat

long messages differently from other messages. Consult your SMS service provider for details.

- “Invalid Number” is displayed if you try to send a message to a phone number saved in the handset phonebook, Caller ID list, or redial list that is over 20 digits long.
- When sending a message, “Sending Message” is displayed momentarily, then “Transferring Message” is displayed.
- If your unit is connected to a PBX, store the PBX line access number (page 45).

5.4.2 Displaying / Sending a saved message

- 1 Press [≡/OK].
- 2 Select “SMS”, then press [▶].
- 3 **To access the public mailbox**
Select “Public”, then press [▶].
To access a private mailbox
Select the desired mailbox, press [▶], then enter its password.
- 4 Select “Send List”, then press [▶].
- 5 To display a saved message, press [▲] or [▼] repeatedly to select the message, then press [≡/OK].
 - Messages are displayed in chronological order and by destination phone number.
- 6 To send the message, press [≡/OK], select “Send”, then press [▶].
 - **To send the message to the same destination number**, press [≡/OK], then continue from step 9, “5.4.1 Writing and sending a new message”, page 42.
 - **To send the message to a different destination number**, erase the displayed number by pressing [C/✕], then continue from step 6, “5.4.1 Writing and sending a new message”, page 42.

5.4.3 Editing a saved message

- 1 Press [≡/OK].
- 2 Select “SMS”, then press [▶].
- 3 **To access the public mailbox**
Select “Public”, then press [▶].
To access a private mailbox
Select the desired mailbox, press [▶], then enter its password.
- 4 Select “Send List”, then press [▶].

- 5 Press [▲] or [▼] repeatedly to select the message, then press [≡/OK].
- 6 Press [≡/OK], select “Edit Message”, press [▶], then continue from step 5, “5.4.1 Writing and sending a new message”, page 42.

5.4.4 Erasing saved messages

- 1 Press [≡/OK].
- 2 Select “SMS”, then press [▶].
- 3 **To access the public mailbox**
Select “Public”, then press [▶].
To access a private mailbox
Select the desired mailbox, press [▶], then enter its password.
- 4 Select “Send List”, then press [▶].
- 5 Press [▲] or [▼] repeatedly to select the message, then press [≡/OK].
- 6 Press [≡/OK], select “Erase”, then press [▶].
 - To erase all messages in the selected mailbox, select “Erase All”, then press [▶].
- 7 Select “Yes”, then press [▶].
- 8 Press [✕/0].

5.5 Receiving a message

When an SMS message is received:

- a tone is heard (if the ringer is turned OFF, this tone is not heard)
- “Receiving SMS Message” is displayed
- ☒ is displayed
- the message centre number is stored in the Caller ID list (page 37)

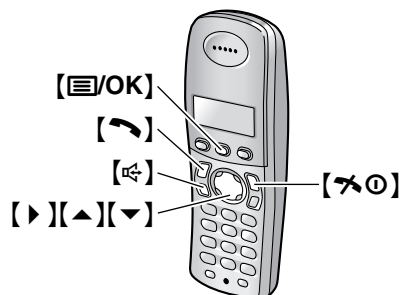

5.5.1 Displaying a received message

- 1 Press [≡/OK].
- 2 Select “SMS”, then press [▶].
- 3 **To access the public mailbox**
Select “Public”, then press [▶].
To access a private mailbox
Select the desired mailbox, press [▶], then enter its password.
 - If a mailbox contains new (unread) SMS messages, “*” is displayed next to the total number of messages for that mailbox.
- 4 Select “Receive List”, then press [▶].
- 5 Press [▲] or [▼] repeatedly to select a message.
 - Messages which have already been read are indicated by a ✓, even if they were read using another handset.
- 6 Press [≡/OK] to read the message content.

Note:

- To call the message sender, press [↶] or [↷].
- If “SMS Full” is displayed, new SMS messages cannot be received. Erase unnecessary messages (page 43, 44).
- If you receive a message from a party saved in the handset phonebook, the stored name is displayed.
- Some SMS service providers attach a 1-digit number to the message sender’s telephone number. As a result, sender names stored in the handset phonebook may not be displayed.

5.5.2 Replying to a message

- 1 While reading a received message, press [≡/OK].
- 2 Select “Reply”, then press [▶].
- 3 Enter a message (page 46), then press [≡/OK].
- 4 Edit the destination telephone number and/or press [≡/OK].
- 5 Continue from step 9, “5.4.1 Writing and sending a new message”, page 42.

Editing/forwarding a message

1. While reading a received message, press [≡/OK].

2. Select “Edit Message”, then press [▶].
3. Continue from step 5, “5.4.1 Writing and sending a new message”, page 42.

5.5.3 Erasing received messages

- 1 While reading a received message, press [≡/OK].
- 2 Select “Erase”, then press [▶].
 - To erase all messages in the selected mailbox, select “Erase All”, then press [▶].
- 3 Select “Yes”, then press [▶].
- 4 Press [↵].

5.5.4 Storing the sender’s number in the handset phonebook

- 1 While reading a received message, press [≡/OK].
- 2 Select “Add Phonebook”, then press [▶].
- 3 Continue from step 3, “4.3.1 Storing phonebook items”, page 31.

5.5.5 Editing the sender’s number before calling back

- 1 While reading a received message, press [≡/OK].
- 2 Select “Edit and Call”, then press [▶].
- 3 Edit the number, then press [↶] or [↷].

5.6 Guide to SMS settings

Important:

- All SMS-related settings and messages will be deleted or reset to their default settings by resetting handset programming that use the base unit PIN (page 80).
- Keep the front cover page open for button locations.

5.6.1 Creating private mailboxes

Private mailboxes can be used for sending and receiving SMS messages. Each private mailbox is password protected.

- 1 Press [≡/OK].
- 2 Select "SMS", then press [▶].
- 3 Select "Public", then press [▶].
- 4 Select "Settings", then press [▶].
- 5 Enter "0000" (default base unit PIN).
 - If you changed the PIN, enter it (page 80).
- 6 Select "Private Mailbox", then press [▶].
- 7 Select the desired new mailbox number ("Mailbox1" to "Mailbox6"), then press [▶].
- 8 Enter a name for the mailbox, up to 5 characters (see page 46 for character entry), then press [≡/OK].
- 9 Enter a 4-digit password for the mailbox, then press [≡/OK].
- 10 Select "Save", then press [▶].
- 11 Press [✕⊙].

Note:

- To receive SMS messages using a mailbox, inform others of your mailbox number.

5.6.2 Changing private mailbox settings

You can change the password or name of the private mailbox and erase the mailbox.

- 1 Press [≡/OK].
- 2 Select "SMS", then press [▶].
- 3 Select "Public", then press [▶].
- 4 Select "Settings", then press [▶].
- 5 Enter "0000" (default base unit PIN).

- If you changed the PIN, enter it (page 80).

- 6 Select "Private Mailbox", then press [▶].
- 7 Select the desired mailbox name, then press [▶] 2 times.
- 8 Enter the mailbox's 4-digit password.
- 9 Edit the mailbox name, up to 5 characters (see page 46 for character entry), then press [≡/OK].
 - To erase the mailbox, press and hold [C/⊗], press [≡/OK], select "Yes", press [▶], then press [✕⊙] to finish.
- 10 Enter a 4-digit password for the mailbox, then press [≡/OK].
- 11 Select "Save", then press [▶].
- 12 Press [✕⊙].

Note:

- If you change the name of a mailbox which has messages in the receive list, the messages will remain in the receive list under the new mailbox name.
- If you erase a mailbox, its messages will also be erased.

5.6.3 Storing the PBX line access number (for PBX users only)

Store your PBX line access number (up to 4 digits) so that SMS messages are sent properly. When sending SMS messages to items in the handset phonebook or redial list, the PBX line access number will be deleted.

- 1 Press [≡/OK].
- 2 Select "SMS", then press [▶].
- 3 Select "Public", then press [▶].
- 4 Select "Settings", then press [▶].
- 5 Enter "0000" (default base unit PIN).
 - If you changed the PIN, enter it (page 80).
- 6 Select "PBX Access No.", then press [▶].
- 7 Select "On", then press [▶].
- 8 Enter your PBX line access number (up to 4 digits) and a dialling pause, if necessary, then press [≡/OK].
- 9 Select "Save", then press [▶].
- 10 Press [✕⊙].

5.7 Available character entries for SMS

Important:

- For character entry when entering the name for phonebook, etc., see page 85.

The handset dial keys are used to enter characters and numbers. Each dial key has multiple characters assigned to it. The available character entry modes are, LetterWise[®], Alphabet, Numeric, Greek and Extended. When in Alphabet (ABC), Greek (ΑΒΓ), or Extended (ΑΆΑ) character entry modes, you can select which character is entered by pressing a dial key repeatedly.

- When the handset displays the character entry screen:
 - Press [◀] or [▶] to move the cursor.
 - Press dial keys to enter characters and numbers.
 - Press [C/⊗] to erase the character or number highlighted by the cursor. Press and hold [C/⊗] to erase all characters or numbers.
 - Press [✳] to switch between uppercase and lowercase.
 - To enter another character located on the same dial key, press [▶] to move the cursor to the next space, then press the appropriate dial key. (This is not necessary when entering text in LetterWise mode.)

5.7.1 Character entry modes

Several character entry modes are available. When the handset displays the character entry screen, press [□□], then select a character entry mode, and press [▶]. The default mode is Alphabet.

LetterWise character table (for English)

LetterWise is a simplified text entry system which suggests the most likely letter to follow the previously entered text. Text can be input faster because the number of key presses are reduced. You can change which language is used for LetterWise character entry (page 77).

How to enter characters

- Each time you press a dial key, LetterWise will suggest a character.
- If the suggested character is incorrect, press [⊕] repeatedly to display the desired character.

0	1	ABC 2	DEF 3	GHI 4	JKL 5	MNO 6	PQRS 7	TUV 8	WXYZ 9
Space 0	Space . @ / : ; * # + - 1 " ' , ! j ? ¿ _ € £ \$ ¥ () [] { } & % \ ^ ~ < > = □ §	A B C 2	D E F 3	G H I 4	J K L 5	M N O 6	P Q R S 7	T U V 8	W X Y Z 9
		a b c 2	d e f 3	g h i 4	j k l 5	m n o 6	p q r s 7	t u v 8	w x y z 9

Alphabet character table (ABC)

0	1	ABC 2	DEF 3	GHI 4	JKL 5	MNO 6	PQRS 7	TUV 8	WXYZ 9
Space 0	Space . @ / : ; * # + - 1 " ' , ! j ? ¿ _ € £ \$ ¥ () [] { } & % \ ^ ~ < > = □ §	A B C 2	D E F 3	G H I 4	J K L 5	M N O 6	P Q R S 7	T U V 8	W X Y Z 9
		a b c 2	d e f 3	g h i 4	j k l 5	m n o 6	p q r s 7	t u v 8	w x y z 9

Numeric entry table (0-9)

0	1	ABC 2	DEF 3	GHI 4	JKL 5	MNO 6	PQRS 7	TUV 8	WXYZ 9
0	1	2	3	4	5	6	7	8	9

Greek character table (ΑΒΓ)

0	1	ABC 2	DEF 3	GHI 4	JKL 5	MNO 6	PQRS 7	TUV 8	WXYZ 9
Space 0	Space . @ / : ; * # + - 1 " ' , ! ; ? ¿ _ € £ \$ ¥ () [] { } & % \ ^ ~ < > = □ §	A B Γ 2	Δ E Z 3	H Θ I 4	K Λ M 5	N Ξ O 6	Π P Σ 7	T Y Φ 8	X Ψ Ω 9

Extended character table (AÄÅ)

0	1	ABC 2	DEF 3	GHI 4	JKL 5	MNO 6	PQRS 7	TUV 8	WXYZ 9
Space 0	Space . @ / : ; * # + - 1 " ' , ! ; ? ¿ _ € £ \$ ¥ () [] { } & % \ ^ ~ < > = □ §	A À Á Â Ã Ä Å Æ B C Ç 2	D E È É Ê Ë Ë F 3	G Ğ H I Ì Í Î Ï 4	J K L 5	M N Ñ O Ö Ó Ô Õ Ö ø 6	P Q R S \$ ß 7	T U Ù Ú Û Ü Û V 8	W X Y Z 9
		a à á â ã ä å æ b c ç 2	d e è é ê ë ë f 3	g ğ h i ì í î ï 4	j k l 5	m n ñ o ò ó ô õ ö ø 6	p q r s \$ ß 7	t u ù ú û ü Û v 8	w x y z 9

- The following are used for both uppercase and lowercase:

ø §

6.1 Sending a fax manually

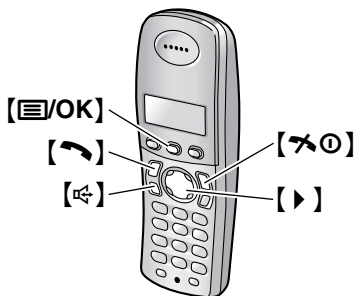
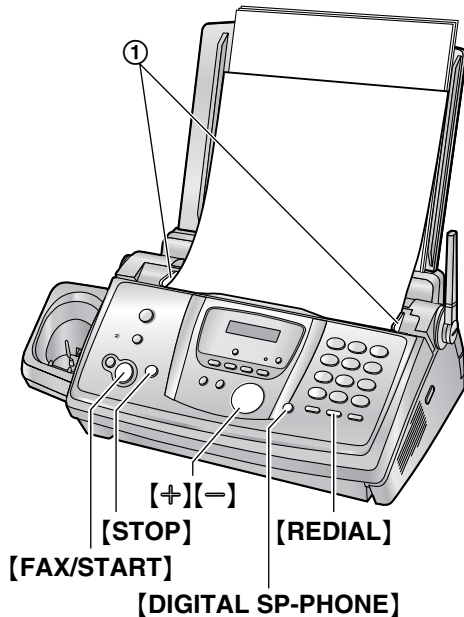

- 1 Adjust the width of the document guides (①) to fit the actual size of the document.
- 2 Insert the document (up to 10 pages) FACE DOWN until a single beep is heard and the unit grasps the document.
 - If the document guides are not adjusted to fit the document, re-adjust them.
- 3 If necessary, press [+] or [-] repeatedly to select the desired resolution.
- 4 Press [DIGITAL SP-PHONE].

- 5 Dial the fax number.
- 6 When a fax tone is heard:
Press [FAX/START].

When the other party answers your call:
Ask them to press their start button. When the fax tone is heard, press [FAX/START].

To select the resolution

Select the desired resolution according to the type of document.

- “STANDARD”: For printed or typewritten documents with normal-sized characters.
- “FINE”: For documents with small print.
- “SUPER FINE”: For documents with very small print. This setting is effective only when the other party has a compatible fax machine.
- “PHOTO”: For documents containing photographs, shaded drawings, etc.
 - Using the “FINE”, “SUPER FINE” and “PHOTO” settings will increase transmission time.
 - If the resolution setting is changed during feeding, it will be effective from the next page.

To redial the last number

1. Press [RECALL].
2. Press [FAX/START].
 - If the line is busy, the unit will automatically redial the number up to 2 times.
 - To cancel redialling, press [STOP].

To send more than 10 pages at a time

Insert the first 10 pages of the document. Add the other pages (up to 10 at a time) on top of the previously inserted pages before the last page feeds into the unit.

To predial a fax number

You can dial the fax number first before inserting the document. This is convenient if you need to refer to the document for the other party's fax number.

1. Enter the fax number.
2. Insert the document.
3. Press [FAX/START].

To send from memory (Quick scan feature)

You can scan the document into memory before sending. To use this feature, activate feature #34 (page 68) beforehand.

1. Insert the document.

2. Enter the fax number.
3. Press **[FAX/START]**.
 - The document will be fed into the unit and scanned into memory. The unit will then transmit the data. If the document exceeds the memory capacity, sending will be cancelled and this feature will be turned OFF automatically. You must send the entire document manually.
 - This feature cannot be used if the handset is in use, or **[DIGITAL SP-PHONE]** on the base unit, **[📞]** or **[📞]** on the handset is pressed.

To send a fax using the handset

1. While talking to the other party, insert the document, then press **[📄/OK]**.
2. Select "Fax Start", then press **[▶]**.
3. Press **[📞]** or place the handset on the base unit.

To stop transmission

Press **[STOP]**.

Printing a sending report

A sending report provides you with a printed record of transmission results. To print sending reports, make sure feature #04 is activated (page 67). For an explanation of error messages, see page 87.

Printing a journal report

A journal report provides you with a printed record of the 30 most recent faxes. To print manually, see page 105. To print automatically after every 30 new fax transmissions and receptions, make sure feature #22 is activated (page 68). For an explanation of error messages, see page 87.

6.2 Documents you can send

Minimum document size

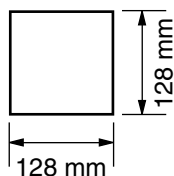

Maximum document size

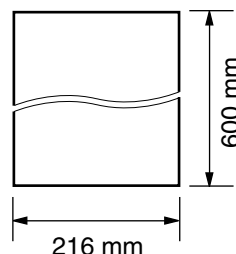

Effective scanning area

- Shaded area will be scanned.

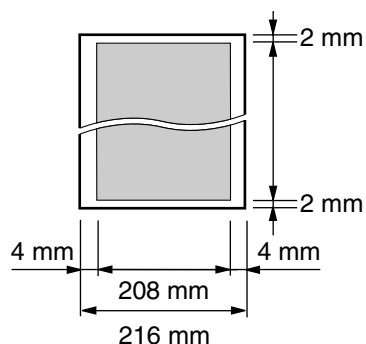

Document weight

- Single sheet: 45 g/m² to 90 g/m²
- Multiple sheets: 60 g/m² to 80 g/m²

Note:

- Remove clips, staples or other fasteners.
- Do not send documents that are on the following types of paper: (Make a copy of the document and send the copy.)
 - Chemically treated paper such as carbon or carbonless duplicating paper
 - Electrostatically charged paper
 - Badly curled, creased or torn paper
 - Paper with a coated surface
 - Paper with a faint image
 - Paper with printing on the opposite side that can be seen through the other side, such as newsprint.
- Check that ink, paste or correction fluid has dried completely.
- To send a document with a width of less than 210 mm, we recommend using a copy machine to copy the original document onto A4 or letter-sized paper, then sending the copied document.

6.3 Sending a fax using the base unit phonebook

Before using this feature, store the desired names and telephone numbers into the base unit phonebook (page 34).

- Keep the front cover page open for button locations.
- 1 Adjust the width of the document guides to fit the actual size of the document.
 - 2 Insert the document (up to 10 pages) FACE DOWN until a single beep is heard and the unit grasps the document.
 - If the document guides are not adjusted to fit the document, re-adjust them.
 - 3 If necessary, press **[+]** or **[-]** repeatedly to select the desired resolution (page 48).
 - 4 Press **[▶]**.
 - 5 Press **[+]** or **[-]** repeatedly to display the desired item and press **[FAX/START]**.

Fax auto redial

If the line is busy or if there is no answer, the unit will automatically redial the number up to 2 times.

- To cancel redialling, press **[STOP]**.

If your unit does not send a fax

- Confirm that you have entered the number correctly, and that the number is a fax number.
- Confirm that the other party's fax machine is answering by turning ON the connecting tone feature (feature #76 on page 70).

6.4 Broadcast transmission

By storing base unit phonebook items (page 34) into the broadcast memory, you can send the same document to multiple parties (up to 20). Your programmed items will remain in the broadcast memory, allowing frequent re-use.

- Keep the front cover page open for button locations.

6.4.1 Programming items into the broadcast memory

- 1 Press **[MENU]** repeatedly to display "PHONEBOOK SET".
- 2 Press **[#]**.
 - The number in brackets indicates the number of registered items.
- 3 Press **[+]** or **[-]** repeatedly to display the desired item.
- 4 Press **[SET]**.
 - To program other items, repeat steps 3 and 4 (up to 20 items).
- 5 Press **[SET]**.

Note:

- If you program the wrong item, press **[STOP]** after step 4 to erase the item.
- Confirm the stored items by printing a broadcast programming list (page 105).

6.4.2 Adding a new item into the broadcast memory

After initial programming, you can add new items (up to a combined total of 20).

- 1 Press **[▶]**.
- 2 Press **[+]** or **[-]** repeatedly to display "<BROADCAST>".
- 3 Press **[MENU]**.
- 4 Press **[*]**.
- 5 Press **[+]** or **[-]** repeatedly to display the desired item you want to add.
- 6 Press **[SET]**.
 - To add other items, repeat steps 5 and 6 (up to 20 items).
- 7 Press **[STOP]**.

6.4.3 Erasing a stored item from the broadcast memory

- 1 Press [▶].
- 2 Press [⊕] or [⊖] repeatedly to display "<BROADCAST>".
- 3 Press [MENU].
- 4 Press [⊞].
- 5 Press [⊕] or [⊖] repeatedly to display the desired item you want to erase.
 - To cancel erasing, press [STOP].
- 6 Press [SET].
- 7 Press [SET].
 - To erase other items, repeat steps 5 to 7.
- 8 Press [STOP].

6.4.4 Sending the same document to pre-programmed parties

- 1 Insert the document FACE DOWN.
- 2 If necessary, press [⊕] or [⊖] repeatedly to select the desired resolution (page 48).
- 3 Press [▶].
- 4 Press [⊕] or [⊖] repeatedly to display "<BROADCAST>".
- 5 Press [FAX/START].
 - The document will be fed into the unit and scanned into memory. The unit will then send the data to each party, calling each number sequentially.
 - After transmission, the stored document will be erased from memory automatically, and the unit will automatically print a report (**Broadcast sending report**).

Note:

- If you select "FINE", "SUPER FINE" or "PHOTO" resolution, the number of pages that the unit can send will decrease.
- If the document exceeds the memory capacity, sending will be cancelled.
- If a party is busy or does not answer, it will be skipped and redialled later up to 2 times.

To send the same document to a one-time group of parties

You can also select a one-time group of parties to send the same document to. After transmission, this group will be deleted.

1. Insert the document.
2. Press [▶].
3. Press [⊕] or [⊖] repeatedly to display "<ONE TIME BROAD>".
4. Press [SET] to start programming the parties you want to send the document to.
5. Press [⊕] or [⊖] repeatedly to display the desired party.
6. Press [SET].
 - To program other parties, repeat steps 5 and 6 (up to 20 items).
7. Press [FAX/START] to start transmission to the programmed parties.

To cancel broadcast transmission

1. Press [STOP] while "BROADCASTING" is displayed.
 - The display will show "SEND CANCELLED?".
2. Press [SET].

6.5 Selecting the way to use your fax machine

Depending on your situation, select the way you prefer to use your fax machine.

Auto receive

- Use as a telephone answering machine and/or fax (TAM/FAX mode)
- Use only as a fax (FAX ONLY mode)

Manual receive

- Use mostly as a telephone (TEL mode)

6.6 Auto receive

6.6.1 Use as a telephone answering machine and/or fax (TAM/FAX mode)

Your situation

You want to answer phone calls using the telephone answering machine and receive faxes automatically.

Setup

Set the fax machine to TAM/FAX mode (page 55) by pressing **[AUTO ANSWER]** repeatedly.

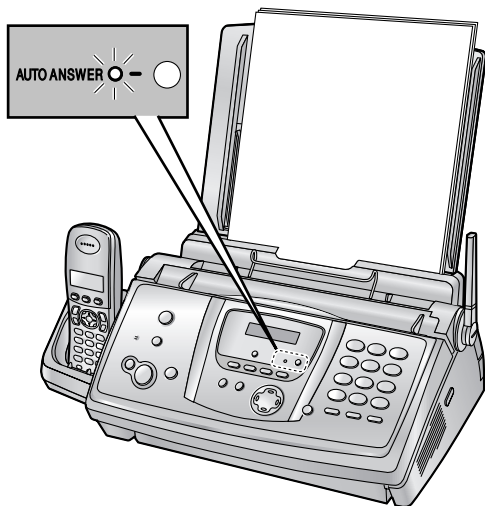

Note:

- Make sure feature #77 is set to “**TAM/FAX**” beforehand (page 70).
- Do not connect an answering machine to the same telephone line. If connected, set the automatic answer feature to OFF by pressing **[AUTO ANSWER]** repeatedly.

How phone calls and faxes are received

If the call is a phone call, the fax machine will record the caller's message automatically.

If a fax calling tone is detected, the fax machine will receive the fax automatically.

6.6.2 Use only as a fax (FAX ONLY mode)

Your situation

You have a separate telephone line just for faxes.

Setup

Set the fax machine to FAX ONLY mode (page 56) by pressing **[AUTO ANSWER]** repeatedly.

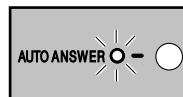

Note:

- Make sure feature #77 is set to “**FAX ONLY**” beforehand (page 70).

How faxes are received

All incoming calls will be answered as faxes.

6.7 Manual receive

6.7.1 Use mostly as a telephone (TEL mode)

Your situation

You want to answer calls by yourself. If a fax call is received, you must receive the fax manually.

Setup

Set the fax machine to TEL mode (page 54) by pressing **[AUTO ANSWER]** repeatedly.

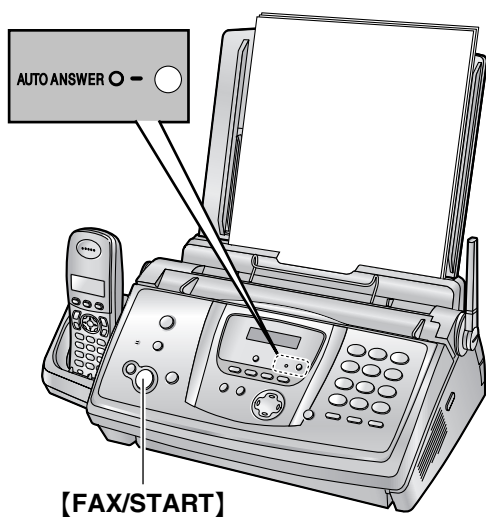

How to receive phone calls and faxes

You have to answer all calls manually.

To receive a fax, press **[FAX/START]**.

6.8 Receiving a fax manually – Auto answer OFF

6.8.1 Activating TEL mode

Set the fax machine to TEL mode by pressing **[AUTO ANSWER]** repeatedly to display the following.

TEL MODE

- The **[AUTO ANSWER]** indicator on the base unit turns OFF.

Note:

- By default, the unit reduces the size of the received document to 92% when printing (See feature #36 on page 69 for details).

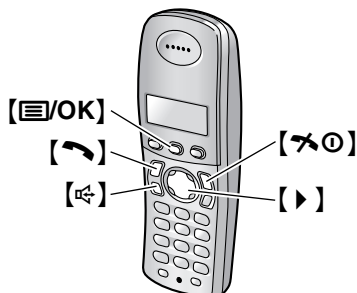
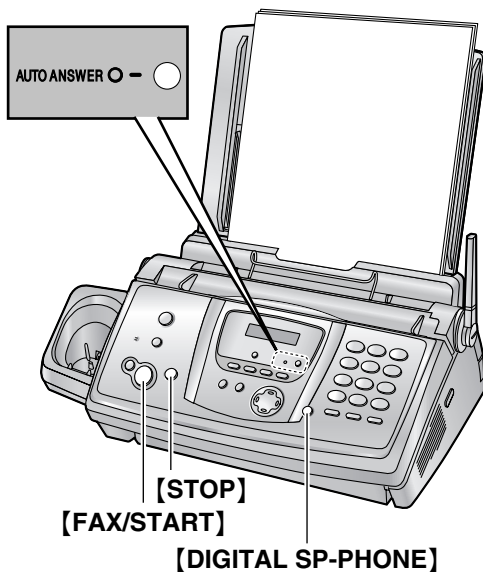

How to receive phone calls and faxes with the base unit

1. Press **[DIGITAL SP-PHONE]** to answer the call.
2. When:
 - document reception is required,
 - a fax calling tone (slow beep) is heard, or
 - no sound is heard,
 press **[FAX/START]**.

CONNECTING

- The unit will start fax reception.

How to receive phone calls and faxes with the handset

1. Lift the handset and press **[STOP]** or **[FAX/START]** to answer the call.
2. When:
 - document reception is required,
 - a fax calling tone (slow beep) is heard, or
 - no sound is heard,
 press **[MENU/OK]**.
3. Select "Fax Start", then press **[▶]**.
4. Press **[FAX/START]** or place the handset on the base unit.

How to receive phone calls and faxes with an extension telephone

If you have another telephone connected to the same line (extension telephone), you can use the extension telephone to receive faxes.

1. When the extension telephone rings, lift the handset of the extension telephone.
2. When:
 - document reception is required,
 - a fax calling tone (slow beep) is heard, or
 - no sound is heard,
 press **[*][#][9]** (default fax activation code) **firmly**.
 - The fax machine will start fax reception.
3. Replace the handset.

Note:

- To receive fax documents using the extension telephone, make sure remote fax activation is turned ON beforehand (feature #41 on page 69). The default setting is ON.

To stop receiving

Press **[STOP]**.

6.9 Receiving a fax automatically – Auto answer ON

6.9.1 Activating TAM/FAX mode

- 1 Make sure feature #77 is set to “**TAM/FAX**” beforehand (page 70).
- 2 Press [**AUTO ANSWER**] repeatedly to display the following.

TAM/FAX MODE

- The [**AUTO ANSWER**] indicator on the base unit turns ON.
- The remaining time for recording incoming messages will be displayed.

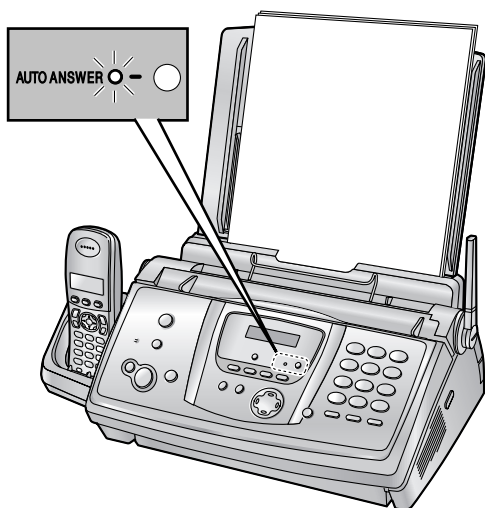

Note:

- The maximum recording time for incoming message can be changed (feature #10 on page 67).
- While an incoming call is being recorded, you can monitor it through the speaker. If this feature is not required, set feature #67 to OFF (page 70).
- If the unit displays the memory is full, erase unnecessary messages (page 62).

How phone calls and faxes are received

When receiving calls, the unit works as an answering machine and/or fax.

- If the call is a phone call, the unit will record the caller's message automatically.

- If a fax calling tone is detected, the unit will receive the fax automatically.

Note:

- By default, the unit reduces the size of the received document to 92% when printing (See feature #36 on page 69 for details).

Receiving a voice message and fax document in one call

The caller can leave a voice message and send a fax document during the same call. Inform the caller of the following procedure beforehand.

1. The caller calls your unit.
 - The answering machine will answer the call.
2. The caller can leave a message after the greeting message.
3. The caller presses [*****][**9**].
 - The unit will activate the fax function.
4. The caller presses the start button to send a fax.

Ring setting in TAM/FAX mode

You can change the number of rings before the unit answers calls. You can choose from “2” (default), “3”, “4”, “5”, “6”, “7”, “8”, “9”, “TOLL SAVER” and “RINGER OFF”. This setting can be changed by feature #06 on page 67.

“TOLL SAVER”: The unit answers after 2 rings when new messages have been recorded, and after 4 rings when there are no new messages. If you call your unit from outside to listen to new messages (page 64), you will know that there are no new messages when the unit rings for the 3rd time. You can then hang up without being charged for the call.

Note:

- To turn the ringer OFF for the handset, see page 24.

6. Fax

6.9.2 Activating FAX ONLY mode

- 1 Make sure feature #77 is set to "FAX ONLY" beforehand (page 70).
- 2 Press **[AUTO ANSWER]** repeatedly to display the following.

FAX ONLY MODE

- The **[AUTO ANSWER]** indicator on the base unit turns ON.

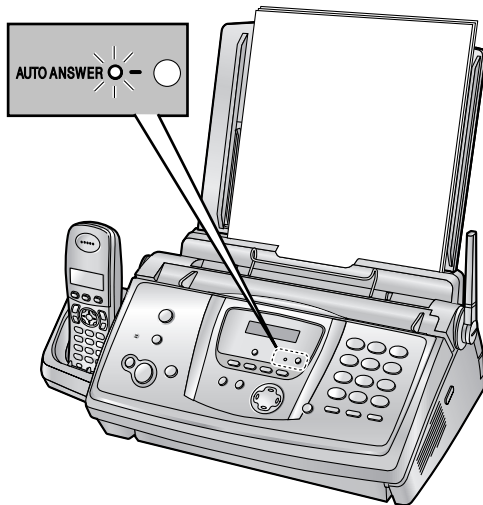

- 1 Press **[MENU]** repeatedly to display "POLLING".
- 2 Press **[SET]**.
- 3 Dial the fax number.
- 4 Press **[SET]**.
 - The unit will start fax reception.

How faxes are received

When receiving calls, the unit will automatically answer all calls and only receive fax documents.

Note:

- The number of rings before a call is answered in FAX ONLY mode can be changed (feature #06 on page 67).
- By default, the unit reduces the size of the received document to 92% when printing (See feature #36 on page 69 for details).

6.10 Receive polling (retrieving a fax placed on another fax machine)

This feature allows you to retrieve a document from another compatible fax machine. Therefore you pay for the call.

Make sure that no documents are fed into your unit and that the other party's machine is ready for your call.

- Keep the front cover page open for button locations.

6.11 Junk fax prohibitor (preventing fax reception from undesired callers)

If you subscribe to Caller ID service, this feature prevents fax reception from calls that do not show caller information.

Additionally, the fax machine will not accept faxes originating from numbers that match a programmable junk fax prohibitor list.

- Keep the front cover page open for button locations.

Important:

- **This feature does not work when manual reception is performed.**

6.11.1 Activating the junk fax prohibitor

- 1 Press **[MENU]** repeatedly to display “**JUNK FAX PROH.**”.
- 2 Press **[▶]**.
- 3 Press **[+]** or **[-]** repeatedly to select “**ON**”.
- 4 Press **[SET]**.
- 5 Press **[MENU]**.
 - While the junk fax prohibitor is activated, “**JUNK FAX ON**” is displayed.

6.11.2 Storing undesired callers

You can register up to 10 undesired numbers from the Caller ID list (page 36) if you do not wish to receive faxes from them.

- 1 Press **[MENU]** repeatedly to display “**JUNK FAX PROH.**”.
- 2 Press **[▶]** repeatedly to display “**JUNK LIST SET**”.
- 3 Press **[SET]**.
- 4 Press **[+]** or **[-]** repeatedly to display the party you wish to prevent fax reception from.
- 5 Press **[SET]**.
 - To program other parties, repeat steps 4 to 5.
- 6 Press **[STOP]** to exit the program.

Note:

- If there is no space to store new items, “**LIST FULL**” is displayed in step 3 or step 5. Erase unnecessary items.

To display the junk fax prohibitor list

1. Press **[MENU]** repeatedly to display “**JUNK FAX PROH.**”.
2. Press **[▶]** repeatedly to display “**JUNK LIST DISP.**”.
3. Press **[SET]**.
4. Press **[+]** or **[-]** repeatedly to display the items on the list.
5. Press **[MENU]** to exit the program.

To print the junk fax prohibitor list

1. Press **[MENU]** repeatedly to display “**JUNK FAX PROH.**”.
2. Press **[▶]** repeatedly to display “**JUNK LIST PRINT**”.
3. Press **[SET]**.
4. Press **[MENU]** to exit the list.

To erase an item from the junk fax prohibitor list

1. Press **[MENU]** repeatedly to display “**JUNK FAX PROH.**”.
2. Press **[▶]** repeatedly to display “**JUNK LIST DISP.**”.
3. Press **[SET]**.
4. Press **[+]** or **[-]** repeatedly to display the desired item.
5. Press **[◀]**.
 - To cancel erasing, press **[STOP]**, then press **[MENU]**.
6. Press **[SET]**.
 - The item is erased.
 - To erase other items, repeat steps 4 to 6.
7. Press **[MENU]** to exit the list.

7.1 Using with the ring detection feature

This feature is only for use if you subscribe to a Distinctive Ring pattern service from your telephone company. For more information on the availability of this service in your area, please contact your telephone company before setting this feature on your unit. In Australia, this service is called "Fax Stream Duet".

In New Zealand, this service is called "FaxAbility".

The Distinctive Ring service gives you an additional phone number on a single telephone line, with a different ringing pattern. When you wish to use the additional phone number as a facsimile telephone number, set the ring pattern detection feature to ON. When the unit detects a call matching the Distinctive Ring pattern, it will receive a fax automatically.

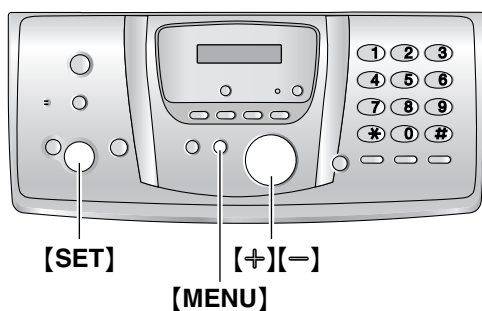

- 1 Press **[MENU]**.
- 2 Press **[*]**, then **[3][1]**.
- 3 Press **[+]** or **[-]** to select "ON".
 - If this feature is not required, select "OFF".
- 4 Press **[SET]**.
- 5 Press **[MENU]**.

8.1 Making a copy

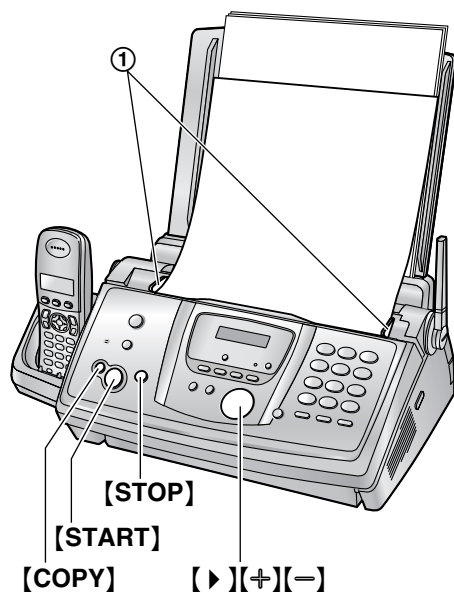

- 1 Adjust the width of the document guides (①) to fit the actual size of the document.
- 2 Insert the document (up to 10 pages) FACE DOWN until a single beep is heard and the unit grasps the document.
 - If the document guides are not adjusted to fit the document, re-adjust them.
- 3 If necessary, press **[+]** or **[-]** repeatedly to select the desired resolution.
- 4 Press **[COPY]**.
 - If necessary, enter the number of copies (up to 30).
- 5 Press **[START]**, or wait for 15 seconds.
 - The unit will start copying.

Note:

- Any document which can be sent as a fax can also be copied (page 49).

To select the resolution

Select the desired resolution according to the type of document.

- “**FINE**”: For printed or typewritten documents with small print.
- “**SUPER FINE**”: For documents with very small print.
- “**PHOTO**”: For documents containing photographs, shaded drawings, etc.
- If you select “**STANDARD**”, copying will be done using “**FINE**” mode.

Quick scan feature

This feature is helpful when you want to copy the document, then remove it for other uses. To use this feature, activate feature #34 (page 68) beforehand. The default setting is OFF.

- The document will be fed into the unit and scanned into memory. The unit will then print the data.

If the document exceeds the memory capacity, copying of the exceeded document will be cancelled and this feature will be turned OFF automatically.

However this feature will not turn OFF automatically when:

- you enter the number of copies, and memory becomes full during copying.
- memory becomes full during enlarge, reduce or collate copy.

To stop copying

Press **[STOP]**.

8.1.1 More copying features

To enlarge a document

1. Insert the document, then press **[COPY]**.
2. Press **[▶]**.
3. Press **[+]** repeatedly to select “150%” or “200%”, then press **[START]**.
 - The unit will only enlarge the centre of the upper part of the document. To make an enlarged copy of the bottom of the document, turn the document around, and then make a copy.

Example: 150% enlarged copy

Original document

Enlarged copy

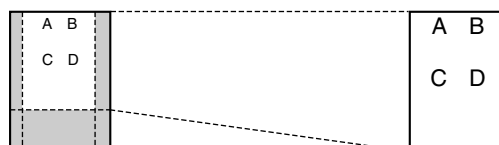

To reduce a document

1. Insert the document, then press **[COPY]**.
2. Press **[▶]**.
3. Press **[-]** repeatedly to select “92%”, “86%” or “72%”, then press **[START]**.

8. Copy

Setting	Recording paper size	Original document size
“100%” (default)	A4	A4, Letter
“92%”	A4	A4
“86%”	A4	A4
“72%”	A4	Legal

A4 = 210 mm × 297 mm

Legal = 216 mm × 356 mm

Letter = 216 mm × 279 mm

Note:

- If the appropriate reduction rate is not selected, the document may be divided and the top of the second sheet will be deleted.
- If the image at the bottom of the document is not copied when you copy a document that is the same length as the recording paper, try 92% or 86%.

To collate multiple copies

The unit can collate multiple copies in the same order as the original document pages.

1. Insert the document, then press **[COPY]**.
2. Enter the number of copies (up to 30).
3. Press **[▶]** 2 times to display “**COLLATE OFF**”.
4. Press **[+]** or **[-]** repeatedly to display “**COLLATE ON**”.
5. Press **[START]**.

Example: Making 2 copies of a 4-page original document

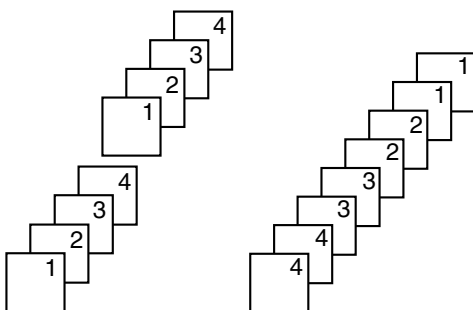

Collated pages

Uncollated pages

Note:

- The unit will store the documents into memory while collating the copies. If memory becomes full while storing, the unit will only print out the stored pages.

- After copying, the collating feature will turn OFF automatically.
- If the unit has run out of recording paper, the unit will scan the document but will not print, and the data will not be stored in the memory. Insert more paper, press **[START]**, then try copying again.

9.1 Recording your greeting message

The unit has a pre-recorded greeting message for TAM/FAX mode. If you record your own greeting message, it will be played instead of the pre-recorded greeting message when a call is received.

You can record your own greeting message for a maximum of 16 (default) or 60 seconds in length. We recommend you record a message of less than 12 seconds to make it easier to receive faxes.

Make sure feature #77 is set to "TAM/FAX" beforehand (page 70).

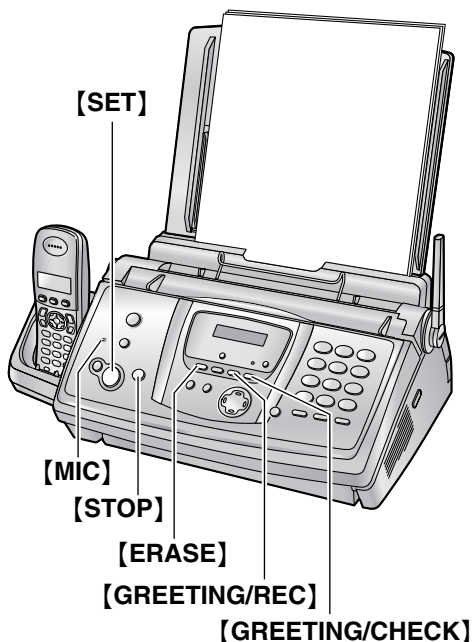

- 1 Press **[GREETING/REC]**.
 - A long beep will sound.
- 2 Speak clearly about 20 cm away from **[MIC]**.
 - The display will show the remaining recording time.
- 3 To stop recording, press **[STOP]**.
 - The unit will repeat your message.

Note:

- You can change the maximum TAM/FAX greeting message recording time to 60 seconds (feature #54 on page 70).
 - If you change the setting to 60 seconds, we recommend that you tell the caller in your TAM/FAX greeting message to press **[*][9]** before starting fax transmission.

- If you change the setting from 60 seconds to 16 seconds, your TAM/FAX greeting message will be deleted. The pre-recorded greeting message will be played when a call is received.

To check the greeting message

Press **[GREETING/CHECK]**.

- The unit will play the greeting message.

9.1.1 Erasing your recorded greeting message

- 1 Press **[ERASE]** 2 times.
- 2 Press **[SET]**.
 - To cancel erasing, press **[STOP]**.
- 3 Press **[SET]**.

Note:

- If you erase your TAM/FAX greeting message, the pre-recorded greeting message will be played when a call is received.

9.2 Listening to recorded messages

When the unit has recorded new voice messages:

- The **[AUTO ANSWER]** indicator will flash when the auto answer setting is turned ON.
- The total number of recorded messages will flash on the base unit display.

Example:

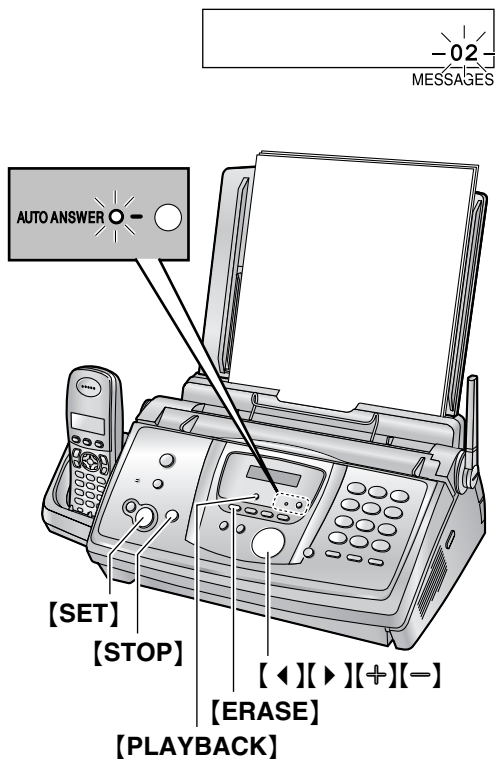

Press **[PLAYBACK]**.

- Only new messages will be played.
- Adjust the speaker volume using **[+]** or **[-]**.
- After playing back all of the new messages;
 - the **[AUTO ANSWER]** indicator will stop flashing but will remain lit up when the auto answer setting is turned ON.
 - the total number of recorded messages will stop flashing and remain displayed.

If you press **[PLAYBACK]** at this time, all recorded messages will be played.

Note:

- The total recording time of all messages (greeting, incoming and memo) is **about 18 minutes**. If messages are recorded in noisy environment, the actual recording time may be less.

To repeat a message

Press **[◀]** while listening to the message.

- If you press **[◀]** within 5 seconds of the beginning of the message, the previous message will be played.
- To play back a specific message, press **[◀]** or **[▶]** and search for the message you want to listen to.

To skip a message

Press **[▶]** to play the next message.

To stop playback temporarily

Press **[STOP]**.

- If you press **[PLAYBACK]** within 1 minute, the unit will resume playing the rest of the messages.

Voice time/day stamp

During playback, the unit will announce the day of the week and time that each message was recorded.

9.2.1 Erasing recorded messages

To erase a specific message

Press **[ERASE]** while listening to the message you want to erase.

To erase all messages

- 1 Press **[ERASE]**.
- 2 Press **[SET]**.
 - To cancel erasing, press **[STOP]**.
- 3 Press **[SET]** again.

9.3 Leaving a message for others or yourself

To leave a private message for yourself or someone else, you can record a voice memo. Recorded messages are treated as new messages. To listen to the recorded messages, see page 62.

- Keep the front cover page open for button locations.

- 1 Press **[MEMO]** to display "MEMO MESSAGE".
- 2 Press **[SET]**.
 - A long beep will sound.
- 3 Speak clearly about 20 cm away from **[MIC]**.

- 4 To stop recording, press **[MEMO]**.
- You can also stop recording by pressing **[STOP]**.

For voice mail/Call minder service subscribers

To receive voice mail/Call minder and use answering system properly, please note the following:

- To use the voice mail/Call minder service provided by your service provider rather than this unit's answering system, change the receiving mode to TEL mode (page 54).
- To use this unit's answering system rather than the voice mail/Call minder service provided by your service provider, please consult your service provider to deactivate your voice mail/Call minder service.

If your service provider cannot do this, set the ring setting in TAM/FAX mode (feature #06 on page 67) so that this unit's answering system answers calls before the service provider's voice mail/Call minder service tries to answer your calls. It is necessary to check the number of rings required to activate the voice mail/Call minder service provided by your service provider before changing this setting.

9.4 Operating from a remote location

You can call your unit from a remote location and access the answering machine.

Important:

- Program the remote operation ID beforehand (feature #11 on page 67).
- Set the unit to TAM/FAX mode before going out (page 55).
- Use a touch tone telephone for remote operations.

Helpful hints:

- When you press a key, press firmly.
- Please make a copy of the following table, and carry it with you when you go out.

Answering machine remote operation			
1. Call your unit.		[5]	Plays all messages
2. Enter the remote operation ID during or after the TAM/FAX greeting message.		[7]	Records greeting message
3. Enter a remote command within 10 seconds.		[9]	Stops recording of the greeting message
Key	Remote command	[*][4]	Erases a specific message
[1]	Repeats a message	[*][5]	Erases all messages
[2]	Skips a message	[0]	Skips the greeting message
[4]	Plays new messages	[8][0]	Turns OFF auto answer setting

9.4.1 Summary of remote operation

- 1 Call your unit.
- 2 During the TAM/FAX greeting message, enter the remote operation ID.
- 3 **When there are new recorded messages**
 1. A long beep will sound.
 2. Short beep(s) will sound up to 8 times.
 - This indicates the number of new messages.
 3. New messages will be played back.

When there are no new messages

1. A long beep will sound (short beep will not sound).
 2. Press [5].
 3. All the recorded messages will be played back.
- 4 To end remote operation, hang up.

Note:

- When the voice memory is full, 6 beeps will sound after playing back the recorded messages. Erase any unnecessary messages.

9.4.2 Remote operation using remote commands

[1] Repeat (During playback)

- The current message is repeated.
- If pressed within 5 seconds of playback, the previous message will be played.

[2] Skip (During playback)

- The current message is skipped. The next message is played.

[4] New message playback

- New messages are played back.

[5] All message playback

- All messages are played back.

[7] Record greeting message

- Speak after the long beep and press [9] to stop the operation.

[9] Stop

- Recording of the greeting message is stopped.

[*][4] Erase a specific message (During playback)

- The current message is erased and the next message will be played.

[*][5] Erase all messages

- All recorded messages are erased.

[0] Skip greeting message

- The greeting message is skipped.

[8][0] Turn OFF auto answer setting

- You cannot return to TAM/FAX mode in the same call.

To turn ON the auto answer setting

1. Call your unit and wait for 15 rings.
 - A beep will sound.
2. Enter the remote operation ID (feature #11 on page 67) within 8 seconds.
 - The auto answer setting will be turned ON. The receiving mode will be set to TAM/FAX or FAX ONLY mode, depending on the setting of feature #77 (page 70).
3. Hang up the handset.

Recording a marker message

After playing back the messages, you can leave an additional message.

1. Wait for 3 beeps indicating the end of the remote operation.
2. Hear 1 beep.
3. Wait about 10 seconds.
4. Hear the voice guide or hear 1 beep.
5. Leave a message.

Note:

- If you do not enter a remote command key within 10 seconds after the last operation, the unit will ask you to leave a marker message.

10.1 Base unit programming

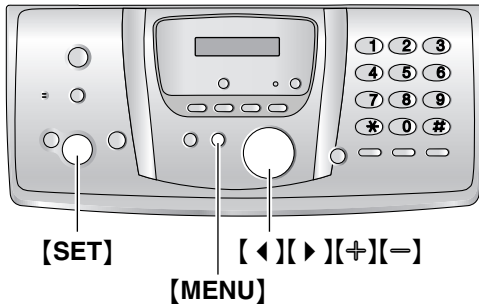

10.1.1 Programming basic features

- 1 Press **[MENU]**.
- 2 Select the feature you wish to program. Press **[◀]** or **[▶]** repeatedly to display the desired feature.
 - The current setting of the feature will be displayed.
- 3 Press **[+]** or **[-]** repeatedly to display the desired setting.
 - This step may be slightly different depending on the feature.
- 4 Press **[SET]**.
 - The setting you selected is set, and the next feature will be displayed.
- 5 To exit programming, press **[MENU]**.

10.1.2 Programming advanced features

- 1 Press **[MENU]**.
- 2 Press **[◀]** or **[▶]** repeatedly to display "ADVANCE SETTINGS".
- 3 Press **[SET]**.
- 4 Select the feature you wish to program. Press **[◀]** or **[▶]** repeatedly to display the desired feature.
 - The current setting of the feature will be displayed.
- 5 Press **[+]** or **[-]** repeatedly to display the desired setting.
 - This step may be slightly different depending on the feature.

- 6 Press **[SET]**.
 - The setting you selected is set, and the next feature will be displayed.
- 7 To exit programming, press **[MENU]** at any time.

To program by entering the program code number directly

You can select a feature by directly entering its program code (# and a 2-digit number) instead of using **[◀]** or **[▶]**.

1. Press **[MENU]**.
2. Press **[#]** and the 2-digit code (page 67 to page 70).
3. Press **[+]** or **[-]** repeatedly to display the desired setting.
 - This step may be slightly different depending on the feature.
4. Press **[SET]**.
5. To exit programming, press **[MENU]**.

To cancel programming

Press **[MENU]** to exit.

10.2 Basic features

Code #01: Setting the date and time

```
SET DATE & TIME
PRESS SET
```

See page 26 for details.

Code #02: Setting your logo

```
YOUR LOGO
PRESS SET
```

See page 26 for details.

Code #03: Setting your fax number

```
YOUR FAX NO.
PRESS SET
```

See page 28 for details.

Code #04: Printing a sending report

```
SENDING REPORT
=ERROR [±]
```

To print a sending report for fax transmission results (page 49).

“**ERROR**” (default): A sending report will be printed only when fax transmission fails.

“**ON**”: A sending report will be printed after every transmission.

“**OFF**”: Sending reports will not be printed.

Code #06: Changing the ring setting in FAX ONLY mode

```
FAX RING COUNT
RINGS=2 [±]
```

To change the number of rings before the unit answers a call in FAX ONLY mode.

You can select “2” (default), “3”, “4”, “5”, “6”, “7”, “8” or “9”.

Note:

- Set feature #77 to “**FAX ONLY**” (page 70) beforehand.

Code #06: Changing the ring setting in TAM/FAX mode

```
TAM RING COUNT
RINGS=2 [±]
```

To change the number of rings before the unit answers a call in TAM/FAX mode. You can select “2” (default), “3”, “4”, “5”, “6”, “7”, “8”, “9”, “**TOLL SAVER**” or “**RINGER OFF**”. See page 55 for details.

Note:

- Set feature #77 to “**TAM/FAX**” (page 70) beforehand.

Code #10: Changing the maximum recording time for incoming messages

```
RECORDING TIME
=VOX [±]
```

“**VOX**” (default): Unlimited.

“**1 MIN**”–“**9 MIN**”: 1 minute to 9 minutes.

Code #11: Setting the remote operation ID

```
REMOTE TAM ID
=ON [±]
```

1. Press [**MENU**].
2. Press [**⏏**], then [**1**][**1**].
3. Press [**+**] or [**-**] repeatedly to select “**ON**”.
4. Press [**SET**].
5. Enter any 3-digit number except a number using 0 or 7.
 - The default ID is “222”.
6. Press [**SET**].
7. Press [**MENU**].

Code #17: Setting the ring tone for outside calls

```
EXT. RINGTONE
=A [±]
```

To set the base unit ring tone from one of 3 tones for outside calls. You can select “**A**” (default), “**B**” or “**C**”.

Note:

- To set the handset ring tone, see page 75.

10.3 Advanced features

Code #22: Setting the journal report to print automatically

AUTO JOURNAL =ON [±]

“ON” (default): The unit will print a journal report automatically after every 30 new fax transmissions and receptions (page 49).

“OFF”: The unit will not print a journal report, but will keep a record of the last 30 fax transmissions and receptions.

Code #23: Sending documents overseas

OVERSEAS MODE =ERROR [±]

If you cannot send a fax overseas even if the number is correct and the line is connected, activate this feature before sending the fax. This feature improves the reliability by reducing the transmission speed.

“ERROR” (default): When the previous fax transmission fails and you wish to re-send the document.

“NEXT FAX”: This setting is effective only for the next attempted fax transmission. After transmission, the unit will return to the previous setting.

“OFF”: Deactivates this feature.

Note:

- This feature is not available for broadcast transmission.
- Calling charges may be higher than usual.

Code #25: Sending a fax at a specific time

DELAYED SEND =OFF [±]

This feature allows you to take advantage of low-cost calling hours offered by your telephone company. This feature can be set up to 24 hours in advance of the desired time.

To send a document:

1. Insert the document.
2. If necessary, press **[+]** or **[-]** repeatedly to select the desired resolution (page 48).
3. Press **[MENU]**.
4. Press **[#]** then **[2][5]**.
5. Press **[+]** or **[-]** repeatedly to select “ON”.
6. Press **[SET]**.
7. Enter the fax number.

8. Press **[SET]**.

9. Enter the transmission start time.
 - If you select 12-hour time entry when you set the date and time (page 26), press **[*]** repeatedly to select “AM” or “PM”.
 - If you selected 24-hour time entry when you set the date and time (page 26), the time is set using 24-hour time entry.

10. Press **[SET]**.

11. Press **[MENU]**.

Note:

- To cancel after programming, press **[STOP]** then **[SET]**.

Code #26: Setting the Caller ID list to print automatically

AUTO CALL. LIST =OFF [±]

“ON”: The Caller ID list will be printed automatically each time the base unit logs 30 different callers (page 36).

“OFF” (default): The Caller ID list will not be printed, but the base unit will keep a record of the information for the last 30 different callers.

Code #31: Activating the Distinctive Ring feature

DISTINCTIVE RING =OFF [±]

See page 58 for details.

Code #34: Setting the quick scan

QUICK SCAN =OFF [±]

This feature is helpful when you want to remove the document for other uses, because the unit will release the document before sending or copying.

“ON”: The unit will scan the document and store it into memory first, then the unit will start sending or copying.

“OFF” (default): Deactivates this feature.

Note:

- If the document exceeds the memory capacity, sending of the whole document or copying of the exceeded document will be cancelled and this feature will be turned OFF automatically.
However this feature will not turn OFF automatically when:
 - you enter the number of copies, and memory becomes full during copying.

- memory becomes full during enlarge, reduce or collate copy.

Code #36: Receiving oversized documents

RCV REDUCTION
=92% [±]

If the size of the document sent by the other party is as large as, or larger than the recording paper, the unit can reduce the document and print it. Select the desired reduction rate.

Setting	Recording paper size	Original document size
"100%"	A4	Letter
"92%" (default)	A4	A4
"86%"	A4	A4
"72%"	A4	Legal

Note:

- The information of the sending party is printed on the top of each page. Therefore, even if the original document is the same size as the recording paper, the document will be divided into 2 sheets when printed at "100%". Select "92%" to print on 1 sheet.

Code #39: Changing the display contrast

LCD CONTRAST
=NORMAL [±]

"NORMAL" (default): For normal contrast.
"DARKER": Used when the display contrast is too light.

Code #41: Changing the fax activation code

FAX ACTIVATION
=ON [±]

If you wish to use the extension telephone (page 54) to receive faxes, activate this feature and program the activation code.

1. Press **[MENU]**.
2. Press **[#]**, then **[4][1]**.
3. Press **[+]** or **[-]** repeatedly to select "ON".
4. Press **[SET]**.
5. Enter your code (2 to 4 digits) using the dial keys **[0]-[9]**, **[*]** and **[#]**.
 - The default code is "*#9".
 - Do not enter "0000".
6. Press **[SET]**.
7. Press **[MENU]**.

Code #42: Setting the message alert

MESSAGE ALERT
=OFF [±]

To alert you when a new voice message is recorded. The unit beeps slowly until you listen to the recorded messages.

"ON": You will be alerted to new messages by a beeping sound.

"OFF" (default): Deactivates this feature.

Code #43: Setting the recording time alert

REC. TIME ALERT
=OFF [±]

To alert you with beeps when there is less than 60 seconds of remaining recording time. The slow beeps will continue until you erase the recorded messages (page 62).

"ON": You will be alerted that you have reached the recording time limit by a beeping sound.

"OFF" (default): Deactivates this feature.

Code #44: Setting the memory reception alert

RECEIVE ALERT
=ON [±]

To alert you with a beeping sound when a received fax document is stored into memory due to some existing problem.

The slow beeps will continue until you clear the printing problem and make sure the unit is supplied with enough paper to print the stored document.

"ON" (default): You will be alerted to a reception problem by a beeping sound.

"OFF": Deactivates this feature.

Code #46: Setting friendly reception

FRIENDLY RCV
=ON [±]

To receive a fax automatically when you answer a call using the base unit and hear a fax calling tone (slow beep).

"ON" (default): You do not have to press **[FAX/START]** for fax reception.

"OFF": You have to press **[FAX/START]** for fax reception.

Code #47: Setting the voice guidance

VOICE GUIDANCE
=ON [±]

If you wish to hear voice guidance, activate this feature.

10. Programmable Features

“ON” (default): You will hear the friendly reception voice guide, pre-recorded messages and voice time/day stamp.

“OFF”: Deactivates this feature.

Code #53: Turning SMS ON/OFF (KX-FC235AL only)

SMS =OFF [±]

See page 41 for details.

Code #54: Changing the recording time for your TAM/FAX greeting message

GREETING TIME =16s [±]

“16s” (default): Maximum recording time is 16 seconds.

“60s”: Maximum recording time is 60 seconds. See page 61 for details.

Code #58: Setting the scan contrast

SCAN CONTRAST =NORMAL [±]

To send or copy a document with faint or dark writing, set this feature before transmission or copying.

“NORMAL” (default): Used for normal writing.

“LIGHT”: Used for dark writing.

“DARKER”: Used for faint writing.

Code #67: Setting the incoming message monitor

ICM MONITOR =ON [±]

To hear an incoming message (ICM) from the speaker when the answering device is recording the message.

“ON” (default): You can monitor the incoming message.

“OFF”: Deactivates this feature.

Code #68: Setting the Error Correction Mode (ECM)

ECM SELECTION =ON [±]

This feature is available when the transmitting/receiving fax machines are ECM compatible.

“ON” (default): If there is an error during fax transmission/reception, the fax machine will support the communication.

“OFF”: Deactivates this feature.

Note:

- You cannot change the setting when received documents are in memory.

Code #76: Setting the connecting tone

CONNECTING TONE =ON [±]

If you often have trouble when sending faxes, this feature allows you to hear connecting tones: fax tone, ring back tone and busy tone. You can use these tones to confirm the status of the other party's machine.

“ON” (default): You will hear connecting tones.

“OFF”: Deactivates this feature.

Note:

- If the ring back tone continues, the other party's machine may not be a fax machine or may have run out of paper. Check with the other party.
- The connecting tone volume cannot be adjusted.

Code #77: Changing the receiving mode in the auto answer setting

AUTO ANSWER =TAM/FAX [±]

“TAM/FAX” (default): Telephone Answering Machine/Fax mode (page 55)

“FAX ONLY”: Fax only mode (page 56)

Code #80: Resetting advanced features to their default settings

SET DEFAULT RESET=NO [±]

To reset the advanced features:

1. Press **[MENU]**.
2. Press **[±]**, then **[8][0]**.
3. Press **[+]** or **[-]** repeatedly to select “YES”.
4. Press **[SET]**.
5. Press **[SET]** again.
6. Press **[MENU]**.

Note:

- The ECM selection (feature #68 on page 70) will not be reset.

10.4 Direct commands for programming features

You can also select the desired setting by directly entering the program code (# and a 2-digit number) and direct command.

For more details on the features, see page 67 to page 70.

- 1 Press **[MENU]**.
- 2 Press **[#]** and the 2-digit code number.
- 3 Press the desired direct command to display the desired setting.
 - This step may be slightly different depending on the feature.
- 4 Press **[SET]**.
- 5 To exit programming, press **[MENU]**.

10.4.1 Program code and direct command button

[#][0][1] Date and time

- Enter the date and time using the dial keypad. See page 26 for details.

[#][0][2] Your logo

- Enter your logo using the dial keypad. See page 26 for details.

[#][0][3] Your fax number

- Enter your fax number using the dial keypad. See page 28 for details.

[#][0][4] Sending report

- **[1]:** "ON"
- **[2]:** "OFF"
- **[3]:** "ERROR" (default)

[#][0][6] FAX ring count

- **[2]:** "2" (default)
- **[3]:** "3"
- **[4]:** "4"
- **[5]:** "5"
- **[6]:** "6"
- **[7]:** "7"
- **[8]:** "8"
- **[9]:** "9"

[#][0][6] TAM ring count

- **[0]:** "RINGER OFF"
- **[1]:** "TOLL SAVER"
- **[2]:** "2" (default)
- **[3]:** "3"

- **[4]:** "4"
- **[5]:** "5"
- **[6]:** "6"
- **[7]:** "7"
- **[8]:** "8"
- **[9]:** "9"

[#][1][0] Message recording time

- **[0]:** "VOX" (default)
- **[1]:** "1 MIN"
- **[2]:** "2 MIN"
- **[3]:** "3 MIN"
- **[4]:** "4 MIN"
- **[5]:** "5 MIN"
- **[6]:** "6 MIN"
- **[7]:** "7 MIN"
- **[8]:** "8 MIN"
- **[9]:** "9 MIN"

[#][1][1] Remote operation ID

- **[1]:** "ON" (default)
- **[2]:** "OFF"
- If you select "ON", enter a 3-digit number except a number using 0 or 7.

[#][1][7] External ring tone

- **[1]:** "A" (default)
- **[2]:** "B"
- **[3]:** "C"

[#][2][2] Automatic journal report

- **[1]:** "ON" (default)
- **[2]:** "OFF"

[#][2][3] Overseas mode

- **[1]:** "NEXT FAX"
- **[2]:** "OFF"
- **[3]:** "ERROR" (default)

[#][2][5] Delayed transmission

- **[1]:** "ON"
- **[2]:** "OFF" (default)
- If you select "ON", next enter the fax number and transmission time using the dial keypad (see feature #25 on page 68 for details).

[#][2][6] Automatic Caller ID list

- **[1]:** "ON"
- **[2]:** "OFF" (default)

[#][3][1] Distinctive Ring

- **[1]:** "ON"
- **[2]:** "OFF" (default)

[#][3][4] Quick scan

- **[1]:** "ON"
- **[2]:** "OFF" (default)

[*][3][6] Receiving reduction

- [1]: "72%"
- [2]: "86%"
- [3]: "92%" (default)
- [4]: "100%"

[*][3][9] Display contrast

- [1]: "NORMAL" (default)
- [2]: "DARKER"

[*][4][1] Fax activation code

- [1]: "ON" (default)
- [2]: "OFF"
- If you select "ON", next enter your 2 to 4 digit code using [0]–[9], [*] and [#].

[*][4][2] Message alert

- [1]: "ON"
- [2]: "OFF" (default)

[*][4][3] Recording time alert

- [1]: "ON"
- [2]: "OFF" (default)

[*][4][4] Memory reception alert

- [1]: "ON" (default)
- [2]: "OFF"

[*][4][6] Friendly reception

- [1]: "ON" (default)
- [2]: "OFF"

[*][4][7] Voice guidance

- [1]: "ON" (default)
- [2]: "OFF"

[*][5][3] SMS (KX-FC235AL only)

- [1]: "ON"
- [2]: "OFF" (default)

[*][5][4] Greeting recording time

- [1]: "16s" (default)
- [2]: "60s"

[*][5][8] Scan contrast

- [1]: "NORMAL" (default)
- [2]: "LIGHT"
- [3]: "DARKER"

[*][6][7] Incoming message monitor

- [1]: "ON" (default)
- [2]: "OFF"

[*][6][8] ECM selection

- [1]: "ON" (default)
- [2]: "OFF"

[*][7][6] Connecting tone

- [1]: "ON" (default)
- [2]: "OFF"

[*][7][7] Auto answer

- [1]: "FAX ONLY"
- [2]: "TAM/FAX" (default)

[*][8][0] Set default

- [1]: "YES"
- [2]: "NO" (default)
- If you select "YES", press [SET] 2 times, then press [MENU] to exit programming.

10.5 Handset programming

- When customising, the current item or setting is indicated by ▶.

Menu	Sub-menu	Sub-menu 2	Default setting	Page	
"Time Settings"	"Set Date & Time"		-----	page 25	
	"Alarm"		"Off"	page 75	
"Ringer Setup"	"Ringer Volume"		Maximum	page 24	
	"Ext. Ringtone"		"Ringtone 1"	page 75	
	"Int. Ringtone"		"Ringtone 1"	page 75	
	"Night Mode"	"Start/End"		23:00/06:00	page 76
		"On/Off"		"Off"	page 75
		"Ring Delay"		"60 sec."	page 76
		"Select Category"		-----	page 76
"Display Setup"	"Standby Display"		"Off"	page 76	
	"Select Language"		"English"	page 76	
	"Contrast"		Level 3	page 77	
"Call Options"	"Call Bar"		-----	page 77	
	"Auto Talk"		"Off"	page 77	
"Registration"	"Register H.set"		-----	page 81	
"Select Base"	-----		"Auto"	page 81	
"Other Options"	"Handset PIN"		"0000"	page 77	
	"LetterWise" (KX-FC235AL only)		"English"	page 77	
	"Keytones"		"On"	page 77	
	"Reset Handset"		-----	page 77	

Using the base unit PIN

Menu	Sub-menu	Sub-menu 2	Default setting	Page
"Call Options"	"Recall"		"100 msec."*1	page 78
	"Pause Length"		"3 sec."	page 78
	"Emergency No."		"000" and "106"*2	page 79
	"ARS Settings"	"Area Code"	-----	page 79
	"Call Restrict"		-----	page 79
"Other Options"	"Base Unit PIN"		"0000"	page 80
	"Repeater Mode"		"Off"	page 82
	"Reset Base"		-----	page 80

10. Programmable Features

For KX-FC231NZ, the default settings are as following.

*1 "600 msec."

*2 "111", "911" and "999"

Note:

- Up to 3 menu items can be displayed at a time. To select a menu item not shown on the current page, scroll up or down by pressing the navigator key, [▲] or [▼], respectively.

10.5.1 Programmable functions

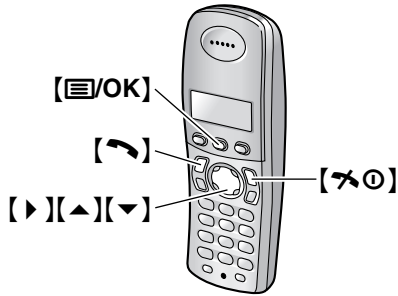

Helpful hints:

- To exit programming, press [*0] at any time.

10.5.2 Alarm

Setting alarm

An alarm will sound for 3 minutes at the set time once or daily.

Set the date and time beforehand (page 25).

1. Press [M/OK].
2. Select "Handset Setup", then press [Right Arrow].
3. Select "Time Settings", then press [Right Arrow].
4. Select "Alarm", then press [Right Arrow] 2 times.
5. Select an alarm mode, then press [Right Arrow].
 - "Once": The alarm will sound once at the set time. Enter the desired day and month by selecting 2 digits for each.
 - "Daily": An alarm will sound daily at the set time.
 - "Off" (default): Turns the alarm OFF. Press [Right Arrow] again, then press [*0] to finish.
6. Enter the desired hour and minute by selecting 2 digits for each.
 - You can select "AM", "PM" or 24-hour time entry by pressing [*] repeatedly.
7. Press [M/OK].
8. Select the ring tone that will sound at the set time, then press [Right Arrow].
9. Select "Save", then press [Right Arrow].
10. Press [*0].

Note:

- To stop the alarm, press any dial key.
- When the handset is in talk or intercom mode, the alarm will not sound until the call has ended.
- Alarm volume depends on handset ringer volume (page 24).

- The alarm will sound at the set time even when the ringer is turned OFF.
- If you select "Once", the setting will be changed to "Off" after the alarm sounds.

10.5.3 Ringer options

Changing ring tones

You can choose the ring tone used by the handset.

"Ext. Ringtone": Selects the ring tone for outside calls.

"Int. Ringtone": Selects the ring tone for intercom calls.

1. Press [M/OK].
2. Select "Handset Setup", then press [Right Arrow].
3. Select "Ringer Setup", then press [Right Arrow].
4. Select the desired item, then press [Right Arrow].
5. Select the desired ring tone, then press [Right Arrow].
6. Press [*0].

Note:

- If you select one of the melody ring tones, the ring tone will continue to sound for several seconds if the caller hangs up before you answer. You may hear a dial tone or no one on the line when you answer a call.
- The preset melodies in this product are used with permission of © 2004 M-ZoNE Co., Ltd.
- To set the base unit ring tone, see feature #17 on page 67.

10.5.4 Night mode

Night mode allows you to select a block of time during which the handset will not ring for outside calls. This feature is useful for times when you do not want to be disturbed, for example, while sleeping.

Using the handset phonebook's category feature (page 32), you can also select categories of callers whose calls will override night mode and ring the handset (Caller ID users only).

Set the date and time beforehand (page 25).

Note:

- The base unit will ring regardless of this setting.

Setting night mode ON/OFF

1. Press [M/OK].
2. Select "Handset Setup", then press [Right Arrow].
3. Select "Ringer Setup", then press [Right Arrow].
4. Select "Night Mode", then press [Right Arrow].
5. Select "On/Off", then press [Right Arrow].

10. Programmable Features

6. Select “On” or “Off” (default), then press [▶].
7. Press [✱⓪].

Note:

- When the night mode is turned ON, “[N]” is displayed.
- Set the receiving mode to TEL mode.

Setting the start and end time for night mode

1. Press [≡/OK].
2. Select “Handset Setup”, then press [▶].
3. Select “Ringer Setup”, then press [▶].
4. Select “Night Mode”, then press [▶].
5. Select “Start/End”, then press [▶].
6. Enter the desired hour and minute you wish to start this feature by selecting 2 digits for each.
 - If you use 12-hour time entry, select “AM” or “PM” by pressing [✱] repeatedly before entering the time.
7. Enter the desired hour and minute you wish to end this feature by selecting 2 digits for each.
 - If you use 12-hour time entry, select “AM” or “PM” by pressing [✱] repeatedly before entering the time.
8. Press [≡/OK].
9. Press [✱⓪].

Setting the ring delay for night mode

This setting allows the handset to ring during night mode if the caller waits long enough. After the selected delay time has passed, the handset will ring. If you select “No Ringing”, the handset will not ring during night mode.

1. Press [≡/OK].
2. Select “Handset Setup”, then press [▶].
3. Select “Ringer Setup”, then press [▶].
4. Select “Night Mode”, then press [▶].
5. Select “Ring Delay”, then press [▶].
6. Select “30 sec.”, then press [▶].
7. Press [✱⓪].

Note:

- We recommend you select “30 sec.”. This is because the base unit detects an incoming call prior to handset.

Selecting categories to bypass night mode

1. Press [≡/OK].

2. Select “Handset Setup”, then press [▶].
3. Select “Ringer Setup”, then press [▶].
4. Select “Night Mode”, then press [▶].
5. Select “Select Category”, then press [▶].
6. Press the desired category numbers, then press [≡/OK].
 - The selected category number will flash.
 - To cancel a selected category number, press the number again. The number will stop flashing.
7. Press [✱⓪].

10.5.5 Display setup

Selecting the standby mode display

“Base Number”: The current base unit number is displayed.

“Handset Number”: The current handset number is displayed.

“Off” (default): Only the current date and time are displayed.

1. Press [≡/OK].
2. Select “Handset Setup”, then press [▶].
3. Select “Display Setup”, then press [▶].
4. Select “Standby Display”, then press [▶].
5. Select the desired setting, then press [▶].
6. Press [✱⓪].

Note:

- If “Base Number” is selected and the current base unit number is 2, “-2-” is displayed.
- If “Handset Number” is selected and the current handset number is 2, “[2]” is displayed.

Changing the display language

1. Press [≡/OK].
2. Select “Handset Setup”, then press [▶].
3. Select “Display Setup”, then press [▶].
4. Select “Select Language”, then press [▶].
5. Select the desired language, then press [▶].
6. Press [✱⓪].

Note:

- If you select a language you cannot read, press [✱⓪], [≡/OK], press [▲] 2 times, press [▶], press [▼] 2 times, press [▶], press [▼], press [▶], select the desired language, then press [▶]. Press [✱⓪].

Changing the display contrast

1. Press [≡/OK].
2. Select "Handset Setup", then press [▶].
3. Select "Display Setup", then press [▶].
4. Select "Contrast", then press [▶].
5. Press [▲] or [▼] repeatedly to select the desired contrast, then press [▶].
6. Press [✎].

10.5.6 Call options

Setting call bar

This feature prohibits making outside calls with the handset. When call bar is turned ON, only intercom calls and emergency calls can be made. To store emergency numbers, see page 79.

1. Press [≡/OK].
2. Select "Handset Setup", then press [▶].
3. Select "Call Options", then press [▶].
4. Select "Call Bar", then press [▶].
5. Enter "0000" (default handset PIN).
 - If you changed the PIN, enter it (page 77).
6. Select "on" or "off" (default), then press [▶].
7. Press [✎].

Note:

- When call bar is turned on, ☒ is displayed.

Setting auto talk

When this feature is turned ON, you can answer calls simply by lifting the handset off the base unit. You do not need to press [↶].

1. Press [≡/OK].
2. Select "Handset Setup", then press [▶].
3. Select "Call Options", then press [▶].
4. Select "Auto Talk", then press [▶].
5. Select "on" or "off" (default), then press [▶].
6. Press [✎].

10.5.7 Other options

Changing the handset PIN (personal identification number)

For security, the handset PIN must be entered when changing certain settings. The default PIN is "0000".

Important:

- If you change the PIN, please make note of your new PIN. The unit will not reveal the PIN to you. If you forget your PIN, consult your nearest Panasonic service centre.

1. Press [≡/OK].
2. Select "Handset Setup", then press [▶].
3. Select "Other Options", then press [▶].
4. Select "Handset PIN", then press [▶].
5. Enter the current 4-digit handset PIN.
6. Enter the new 4-digit handset PIN, then press [≡/OK].
7. Press [✎].

Changing the LetterWise language (KX-FC235AL only)

You can change which language is used for LetterWise character entry (page 46, 85).

1. Press [≡/OK].
2. Select "Handset Setup", then press [▶].
3. Select "Other Options", then press [▶].
4. Select "LetterWise", then press [▶].
5. Select the desired language, then press [▶].
6. Press [✎].

Setting key tone

You can select whether or not key tones are heard when keys are pressed. Includes confirmation tones and error tones.

1. Press [≡/OK].
2. Select "Handset Setup", then press [▶].
3. Select "Other Options", then press [▶].
4. Select "Keytones", then press [▶].
5. Select "on" (default) or "off", then press [▶].
6. Press [✎].

Note:

- If key tones are turned OFF, error tones will not sound when you enter the wrong PIN or when memory is full.

Resetting the handset to its default settings

1. Press [≡/OK].
2. Select "Handset Setup", then press [▶].
3. Select "Other Options", then press [▶].
4. Select "Reset Handset", then press [▶].
5. Enter "0000" (default handset PIN).
 - If you changed the PIN, enter it (page 77).

10. Programmable Features

6. Select “Yes”, then press [▶].
7. Press [✎].

Note:

- The following items will be deleted or reset to their default settings:
 - Settings listed on page 73 (not including items using the base unit PIN)
 - Redial list
 - Voice enhancer
 - Category names
 - Category ring tones
- The following items will be retained:
 - Handset phonebook items (category names and ring tones will be reset to their default settings.)
 - Date and time

10.5.8 Programmable functions using the base unit PIN

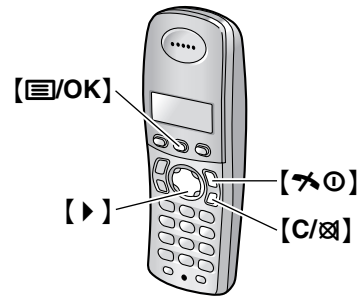

Helpful hints:

- To exit programming, press [✎] at any time.

10.5.9 Call Options

Changing the recall time

Change the recall time of the handset, if necessary, depending on the requirements of your service provider or PBX.

1. Press [OK].
2. Select “Base Unit Setup”, then press [▶].
3. Enter “0000” (default base unit PIN).
 - If you changed the PIN, enter it (page 80).
4. Select “Call Options”, then press [▶].
5. Select “Recall”, then press [▶].
6. Select the desired setting, then press [▶].
7. Press [✎].

Setting pause length

Change the pause length of the handset, if necessary, depending on the requirements of your service provider or PBX.

1. Press [OK].
2. Select “Base Unit Setup”, then press [▶].
3. Enter “0000” (default base unit PIN).
 - If you changed the PIN, enter it (page 80).
4. Select “Call Options”, then press [▶].
5. Select “Pause Length”, then press [▶].
6. Select the desired setting, then press [▶].
7. Press [✎].

Storing/changing emergency numbers

These settings determine which telephone numbers can be dialled while the call bar feature is ON (page 77).

1. Press [≡/OK].
2. Select "Base Unit Setup", then press [▶].
3. Enter "0000" (default base unit PIN).
 - If you changed the PIN, enter it (page 80).
4. Select "Call Options", then press [▶].
5. Select "Emergency No.", then press [▶].
6. Select a memory location, then press [▶].
 - If the memory location already contains an emergency number, the number is displayed.
7. Enter/edit the number, then press [≡/OK].
 - To erase an emergency number, press and hold [C/⊗].
8. Press [↶⊙].

Note:

- The default setting for emergency numbers are stored in the first 2 memory locations (KX-FC235AL)/3 memory locations (KX-FC231NZ). It is recommended that you do not overwrite these numbers.

Selecting area codes to be deleted automatically

In some situations, phone numbers stored automatically in the Caller ID list (page 36) will include area codes. If you do not want to dial the area codes when making calls from the Caller ID list, you can store the area codes which you want the unit to delete automatically.

Example: You have stored the area code "123". If you make a call from the Caller ID list to the phone number "123-456-7890", the unit dials "456-7890".

1. Press [≡/OK].
2. Select "Base Unit Setup", then press [▶].
3. Enter "0000" (default base unit PIN).
 - If you changed the PIN, enter it (page 80).
4. Select "Call Options", then press [▶].
5. Select "ARS Settings", then press [▶].
6. Select "Area Code", then press [▶].
7. Select an area code location (1-4), then press [▶].
 - If the location already contains an area code, the code is displayed.

8. Enter an area code (5 digits max.), then press [≡/OK].
9. Press [↶⊙].

Note:

- The use of this feature can prevent a National Call from being dialled. E.g., in the case of the South Island, the "03" will be omitted and will therefore prevent a National Call to other areas of the South Island. (for New Zealand users only)

Setting call restriction

You can restrict selected handsets from dialling certain numbers. You can assign up to 6 phone numbers to be restricted, and select which handsets will be restricted. Storing area codes here will prevent the restricted handsets from dialling any phone number in that area code. If a restricted number is dialled, the call will not be connected and the restricted number will flash on the display.

1. Press [≡/OK].
2. Select "Base Unit Setup", then press [▶].
3. Enter "0000" (default base unit PIN).
 - If you changed the PIN, enter it (page 80).
4. Select "Call Options", then press [▶].
5. Select "Call Restrict", then press [▶].
6. Set which handsets will be restricted by pressing the desired handset number.
 - All the registered handset numbers will be displayed.
 - Flashing numbers indicate call restriction is turned ON for the corresponding handset.
 - To turn call restriction OFF for a handset, press the number again. The number will stop flashing.
7. Press [≡/OK].
8. Select a memory location, then press [▶].
 - If the memory location already contains a restricted number, the number is displayed.
9. Enter the phone number or area code to be restricted (up to 8 digits), then press [≡/OK].
 - To erase a restricted number, press [C/⊗].
10. Press [↶⊙].

10.5.10 Other options

Changing the base unit PIN (personal identification number)

For security, the base unit PIN must be entered when changing certain settings. The default PIN is “0000”.

Important:

- **If you change the PIN, please make note of your new PIN. The unit will not reveal the PIN to you. If you forget your PIN, consult your nearest Panasonic service centre.**
1. Press [**≡/OK**].
 2. Select “**Base Unit Setup**”, then press [**▶**].
 3. Enter “0000” (default base unit PIN).
 - If you changed the PIN, enter it.
 4. Select “**Other Options**”, then press [**▶**].
 5. Select “**Base Unit PIN**”, then press [**▶**].
 6. Enter the new 4-digit base unit PIN, then press [**≡/OK**].
 7. Press [**↶⓪**].

Resetting handset programming that uses the base unit PIN

Handset programming that uses the base unit PIN will be reset (page 73).

1. Press [**≡/OK**].
2. Select “**Base Unit Setup**”, then press [**▶**].
3. Enter “0000” (default base unit PIN).
 - If you changed the PIN, enter it (page 80).
4. Select “**Other Options**”, then press [**▶**].
5. Select “**Reset Base**”, then press [**▶**].
6. Select “**Yes**”, then press [**▶**].
7. Press [**↶⓪**].

Note:

- The following items will also be deleted or reset to their default settings:
 - All SMS-related settings and messages (KX-FC235AL only, page 41)
 - Caller ID list for the handset (page 37)
- The repeater mode will be retained (page 82).

11.1 Operating additional units

11.1.1 Additional handsets

Up to 6 handsets can be registered to a single base unit. Additional handsets, for example, will allow you to have an intercom call with another handset while a third handset is on an outside call. See page 11 for accessory information.

11.1.2 Additional base units

Handsets can be registered to up to 4 base units, allowing you to add additional base units and extend the area in which your handset(s) can be used. If a handset moves out of range of its base unit when "Auto" is selected on base unit selection (page 81), it will look for another base unit to make or receive calls. Each base unit forms 1 radio cell.

Note:

- Calls will be disconnected when the handset moves from one radio cell to another.
- Intercom calls and call transfers are only possible between handsets in the same radio cell.

11.2 Registering a handset to a base unit

The included handset and base unit are preregistered. After purchasing an additional handset, register it to the base unit. Ensure that the additional handset is switched ON. If it is not ON, press and hold **[✕⊙]** for few seconds to turn the handset ON.

- Keep the front cover page open for button locations.

11.2.1 Easy registration

- 1 Lift the additional handset and press **[✕⊙]** to put the handset in standby mode.
- 2 Press and hold **[LOCATOR]** on the base unit for about 3 seconds, until the registration tone sounds.
- 3 Place the additional handset on the base unit. The registration tone continues to sound. With the handset still on the base unit, wait until a confirmation tone sounds and **Y** stops flashing.

Note:

- If an error tone sounds, or if **Y** is still flashing, register the handset manually.
- If all registered handsets start ringing in step 2, press **[LOCATOR]** to stop. Start again from step 1.
- Charge the batteries of your additional handset for about 7 hours before initial use.
- This registration method cannot be used for handsets that have already been registered to a base unit. Register the handset manually.

11.2.2 Manual registration

- 1 Press **[≡/OK]**.
- 2 Select "Handset Setup", then press **[▶]**.
- 3 Select "Registration", then press **[▶]** 2 times.
- 4 Press and hold **[LOCATOR]** on the base unit for about 3 seconds, until the registration tone sounds.
 - If all registered handsets start ringing, press **[LOCATOR]** to stop, then repeat this step.
 - After pressing **[LOCATOR]**, the rest of this procedure must be completed within 1 minute.
- 5 Select a base unit number, then press **[▶]**.
 - This number is used by the handset as a reference only.
- 6 Wait until "Enter Base PIN" is displayed, then enter "0000" (default base unit PIN), then press **[≡/OK]**.
 - If you changed the PIN, enter it (page 80).
 - When the handset has been registered successfully, **Y** will stop flashing. If key tones are turned ON (page 77), a confirmation tone will be heard.

11.2.3 Selecting a base unit

When "Auto" is selected, the handset will automatically use any available base unit it is registered to. When a specific base unit is selected, the handset will make and receive calls using that base unit only. If the handset is out of range of that base unit, no calls can be made or received.

- 1 Press **[≡/OK]**.
- 2 Select "Handset Setup", then press **[▶]**.
- 3 Select "Select Base", then press **[▶]**.

11. Multi-unit Operation

- 4 Select the desired base unit number, or "Auto", then press [▶].
 - The handset starts searching for the base unit.

11.2.4 Cancelling a handset

A handset can cancel its own registration (or the registration of another handset) that is stored in the base unit. This will allow the base unit to forget the handset.

- 1 Press [≡/OK].
- 2 Select "Base Unit Setup", then press [▶].
- 3 Enter "0000" (default base unit PIN).
 - If you changed the PIN, enter it (page 80).
- 4 Enter "335".
- 5 Select "Cancel Handset", then press [▶].
 - The numbers of all handsets registered to the base unit are displayed.
- 6 Select the handset(s) you want to cancel, by pressing the desired handset number.
 - The selected handset number(s) will flash.
 - To cancel a selected handset number, press the number again. The number will stop flashing.
- 7 Press [≡/OK].
- 8 Select "Yes", then press [▶].

11.2.5 Cancelling a base unit

A handset can cancel a base unit that it is registered to. This allows the handset to forget the base unit.

- 1 Press [≡/OK].
- 2 Select "Handset Setup", then press [▶].
- 3 Select "Registration", then press [▶].
- 4 Enter "335".
- 5 Select "Cancel Base", then press [▶].
- 6 Enter "0000" (default handset PIN).
 - If you changed the PIN, enter it (page 77).
- 7 Select the base unit(s) you want to cancel, by pressing the desired base unit number.
 - The selected base unit number(s) will flash.
 - To cancel a selected base unit number, press the number again. The number will stop flashing.

- 8 Press [≡/OK].

- 9 Select "Yes", then press [▶].

- 10 Press [✕⓪].

Note:

- To register the handset to another base unit or to the same base unit again, see manual registration on page 81.

11.2.6 Increasing the range of the base unit

You can increase the range of the base unit by using a DECT repeater. Please use only Panasonic DECT repeater. See page 11 for accessory information.

Important:

- **Before registering the repeater to this base unit, you must turn the repeater mode ON.**

Setting the repeater mode

1. Press [≡/OK].
2. Select "Base Unit Setup", then press [▶].
3. Enter "0000" (default base unit PIN).
 - If you changed the PIN, enter it (page 80).
4. Select "Other Options", then press [▶].
5. Select "Repeater Mode", then press [▶].
6. Select "On" or "Off" (default), then press [▶].
7. Press [✕⓪].

Note:

- After turning repeater mode ON/OFF, you will not be able to make or receive calls for a few moments.

11.3 Handset locator

Using this feature, you can locate the handset if it has been misplaced.

- Keep the front cover page open for button locations.

- 1 Press [LOCATOR].
 - The base unit will page the handset for about 1 minute.
- 2 To stop paging, press [LOCATOR] on the base unit or [✕⓪] on the handset.

Note:

- This feature is not available while using [DIGITAL SP-PHONE].

11.4 Intercom between handsets

Intercom calls can be made between handsets in the same radio cell, but not in different radio cells.

- Keep the front cover page open for button locations.

Example: When handset 1 calls handset 2

1. Handset 1:

Press **[INT]** and **[2]** (desired handset number).

- The handset 2 will ring.

2. Handset 2:

Press **[↶]** or **[☎]** to answer.

3. When finished talking, press **[✕⊙]**.

11.5 Transferring calls between handsets / Conference calls

Outside calls can be transferred between 2 handsets.

2 people can have a conference call with an outside party.

- Keep the front cover page open for button locations.

Example: When handset 1 transfers a call to handset 2

1. Handset 1:

During an outside call, press **[INT]** and **[2]** (desired handset number).

- The outside call will be put on hold.
- If there is no answer, press **[INT]** or **[↶]** to return to the outside call.

2. Handset 2:

Press **[INT]**, **[↶]** or **[☎]** to answer.

- Handset 2 can talk with handset 1.

3. Handset 1:

To complete the call transfer, press **[✕⊙]**.
To establish a conference call, press **[3]**.

To transfer a call without speaking to the handset 2 user

After step 1, press **[✕⊙]** on the handset 1.

- **[↶]** flashes to indicate the outside call is on hold.
- Handset 2 rings if it is within range of the base unit and turned ON.

- If the transferred call is not answered within 60 seconds, the handset 1 will ring again. Press **[INT]** or **[↶]** to return to the outside call.

11.6 Copying handset phonebook items

Phonebook items (page 31) can be copied from the handset to the phonebook of another handset.

- Keep the front cover page open for button locations.

Copying a stored item

1. Find the desired item (page 32), then press [≡/OK].
2. Select “Copy”, then press [▶].
3. Enter the handset number you wish to send the item to.
4. To continue copying another item, select “Yes”, then press [▶]. Find the desired item, then press [▶].
 - To finish copying, select “No”, then press [▶].
5. Press [✕⓪].

Copying all stored items

1. Press [□], then press [≡/OK].
2. Select “Copy All”, then press [▶].
3. Enter the handset number you wish to send the items to.
 - When all items have been copied, “Completed” is displayed.
4. Press [✕⓪].

Note:

- If the other handset (the receiver) is not in standby mode, “Failed” is displayed on your handset (the sender).
- If copying failed after copying at least 1 item, “Incomplete” is displayed on your handset (the sender).

12.1 Available character entries for the handset

Important:

- For character entry when writing SMS messages, see page 46 (KX-FC235AL only).

The handset dial keys are used to enter characters and numbers. Each dial key has multiple characters assigned to it. The available character entry modes are, LetterWise (KX-FC235AL only), Alphabet, Numeric, Greek, Extended 1, Extended 2, and Cyrillic. When in Alphabet (ABC), Greek (ABΓ), Extended 1 (AÄÅ), Extended 2 (SŠŠ), or Cyrillic (АБВ) character entry modes, you can select which character is entered by pressing a dial key repeatedly.

- When the handset displays the character entry screen:
 - Press [◀] or [▶] to move the cursor.
 - Press dial keys to enter characters and numbers.
 - Press [C/✕] to erase the character or number highlighted by the cursor. Press and hold [C/✕] to erase all characters or numbers.
 - Press [✱] to switch between uppercase and lowercase.
 - To enter another character located on the same dial key, press [▶] to move the cursor to the next space, then press the appropriate dial key. (This is not necessary when entering text in LetterWise mode.)

12.1.1 Character entry modes

Several character entry modes are available. When the handset displays the character entry screen, press [□□], then select a character entry mode, and press [▶]. The default mode is Alphabet.

LetterWise character table for English (KX-FC235AL only)

LetterWise is a simplified text entry system which suggests the most likely letter to follow the previously entered text. Text can be input faster because the number of key presses are reduced. You can change which language is used for LetterWise character entry (page 77).

How to enter characters

- Each time you press a dial key, LetterWise will suggest a character.
- If the suggested character is incorrect, press [⏏] repeatedly to display the desired character.

0	1	ABC 2	DEF 3	GHI 4	JKL 5	MNO 6	PQRS 7	TUV 8	WXYZ 9
Space 0	Space # & ' () * , - . / 1	A B C 2	D E F 3	G H I 4	J K L 5	M N O 6	P Q R S 7	T U V 8	W X Y Z 9
		a b c 2	d e f 3	g h i 4	j k l 5	m n o 6	p q r s 7	t u v 8	w x y z 9

Alphabet character table (ABC)

0	1	ABC 2	DEF 3	GHI 4	JKL 5	MNO 6	PQRS 7	TUV 8	WXYZ 9
Space 0	Space # & ' () * , - . / 1	A B C 2	D E F 3	G H I 4	J K L 5	M N O 6	P Q R S 7	T U V 8	W X Y Z 9
		a b c 2	d e f 3	g h i 4	j k l 5	m n o 6	p q r s 7	t u v 8	w x y z 9

Numeric entry table (0-9)

0	1	ABC 2	DEF 3	GHI 4	JKL 5	MNO 6	PQRS 7	TUV 8	WXYZ 9
0	1	2	3	4	5	6	7	8	9

12. Useful Information

Greek character table (ΑΒΓ)

0	1	ABC 2	DEF 3	GHI 4	JKL 5	MNO 6	PQRS 7	TUV 8	WXYZ 9
Space 0	Space # & ' () * , - . / 1	Α Β Γ 2	Δ Ε Ζ 3	Η Θ Ι 4	Κ Λ Μ 5	Ν Ξ Ο 6	Π Ρ Σ 7	Τ Υ Φ 8	Χ Ψ Ω Ξ 9

Extended 1 character table (AĂÄ)

0	1	ABC 2	DEF 3	GHI 4	JKL 5	MNO 6	PQRS 7	TUV 8	WXYZ 9
Space 0	Space # & ' () * , - . / 1	A Ă Ą Â Ã Ä Å Æ B C Ç 2	D Ę È É Ê Ë Ĕ ĕ 3	G Ğ Ħ I Ì Í Î Ĳ ĳ 4	J K L 5	M N Ń O Ò Ó Ô Õ Ö ø 6	P Q R S Ş ß 7	T U Û Ú Ü Û Ü V 8	W Ŷ X Y ŷ Z 9
		a à á â ã ä å æ b c ç 2	d ě è é ê ë ĕ ė 3	g ğ ħ i ì í î ĳ ģ 4	j k l 5	m n ñ o ò ó ô õ ö ø 6	p q r s ş ß 7	t u ù ú û ü ü v 8	w ŵ x y ŷ z 9

- The following are used for both uppercase and lowercase:

ø Ş Ŵ ŷ

Extended 2 character table (SŠŠ)

0	1	ABC 2	DEF 3	GHI 4	JKL 5	MNO 6	PQRS 7	TUV 8	WXYZ 9
Space 0	Space # & ' () * , - . / 1	A Ā Ă Ą B C Ć Č 2	D Ď Ě É Ę Ě F 3	G Ħ I Í 4	J K L Ł Ł Ł 5	M N Ń Ń Ń Ń Ō Ő 6	P Q R Ŕ Ŕ Š Š Š 7	T Ť U Ú Ú Ú ú v 8	W X Y ŷ Ý Z Ž Ž Ž 9
		a ā ä ą b c ć č 2	d ě e é ě ě f 3	g ħ i í 4	j k l ł ł ł ł 5	m n Ń ń Ń Ń ő ő 6	p q r ŕ ř š š š 7	t ť u ú ú ú ú ú v 8	w x y ŷ ý z ž ž ž 9

- The following are used for both uppercase and lowercase:

Ą Ć Č Ę Ł Ł Ł Ń Ŕ Š Š ŷ ŷ Ž Ž Ž

Cyrillic character table (АБВ)

0	1	ABC 2	DEF 3	GHI 4	JKL 5	MNO 6	PQRS 7	TUV 8	WXYZ 9
Space 0 Г Є І Ї Ы	Space # & ' () * , - . / 1	А Б В Г 2	Д Е Ж З 3	И Ы К Л 4	М Н О П 5	Р С Т У 6	Ф Х Ц Ч 7	Ш Щ Ъ Ы 8	Ь Э Ю Я 9

13.1 Error messages – Reports

If a problem occurs during fax transmission or reception, one of the following messages will be printed on the sending and journal reports (page 49).

COMMUNICATION ERROR

(Code: 40-42, 46-72, FF)

- A transmission or reception error occurred. Try again or check with the other party.

COMMUNICATION ERROR

(Code: 43, 44)

- A line problem occurred. Connect the telephone line cord to a different jack and try again.
- An overseas transmission error occurred. Try using the overseas mode (feature #23 on page 68).

DOCUMENT JAMMED

- The document is jammed. Remove the jammed document (page 101).

ERROR-NOT YOUR UNIT

(Code: 54, 59, 70)

- A transmission or reception error occurred because of a problem with the other party's fax machine. Check with the other party.

JUNK FAX PROH. REJECT

- The fax was rejected by the junk fax prohibitor feature (page 57).

MEMORY FULL

- The memory is full of received documents due to a lack of recording paper, a lack of ink film or a recording paper jam. Install paper (page 19), install ink film (page 16) or clear the jammed paper (page 98).

NO DOCUMENT

- The document was not fed into the unit properly. Re-insert it and try again.

OTHER FAX NOT RESPONDING

- The other party's fax machine is busy or has run out of recording paper. Try again.
- The other party's fax machine rings too many times. Send the fax manually (page 48).
- The other party's machine is not a fax machine. Check with the other party.
- The number you dialled is not in service.

PRESSED THE STOP KEY

- **[STOP]** was pressed, and fax transmission or reception was cancelled.

OK

- Fax transmission or reception was successful.

13.2 Error messages – Base unit display

If the unit detects a problem, one or more of the following messages will appear on the display.

Display	Cause and Solution
“CALL SERVICE”	<ul style="list-style-type: none"> There is something wrong with the unit. Contact our service personnel.
“CHECK DOCUMENT”	<ul style="list-style-type: none"> The document was not fed into the unit properly. Re-insert the document. If misfeeding occurs frequently, clean the document feeder rollers (page 102) and try again. Attempted to send a document longer than 600 mm. Press [STOP] to remove the document. Divide the document into two or more sheets and try again.
“CHECK FILM”	<ul style="list-style-type: none"> The ink film is empty. Replace the ink film with a new one (page 18). The ink film is not installed. Install it (page 16). The ink film is slack or creased. Tighten it (see step 5 on page 17).
“CHECK MEMORY”	<ul style="list-style-type: none"> Memory (telephone numbers, parameters, etc.) has been erased. Re-program.
“CHECK PAPER”	<ul style="list-style-type: none"> Recording paper is not installed or the unit has run out of paper. Install paper and press [START] to clear the message. The recording paper was not fed into the unit properly (page 100). Reinstall paper (page 19) and press [START] to clear the message. The recording paper has jammed near the recording paper entrance. Clear the jammed paper (page 98) and press [START] to clear the message.
“COVER OPEN”	<ul style="list-style-type: none"> The back cover is open. Close it.
“FAX IN MEMORY”	<ul style="list-style-type: none"> The unit has a document in memory. See the other displayed message instructions to print out the document. For fax memory capacity, see page 106.
“FAX MEMORY FULL”	<ul style="list-style-type: none"> The memory is full of received documents due to a lack of recording paper, a lack of ink film or a recording paper jam. Install paper (page 19), install ink film (page 16) or clear the jammed paper (page 98). When performing memory transmission, the document being stored exceeded the memory capacity of the unit. Send the entire document manually.
“FILM EMPTY”	<ul style="list-style-type: none"> The ink film is empty. Replace the ink film with a new one (page 18). The ink film is slack. Tighten it (see step 5 on page 17) and install again. The fax machine is positioned near appliances such as TVs or speakers which generate an intense magnetic field.
“FILM NEAR EMPTY”	<ul style="list-style-type: none"> The remaining ink film is low. Prepare a new ink film (page 11).
“MEMORY FULL”	<ul style="list-style-type: none"> When making a copy, the document being stored exceeded the memory capacity of the unit. Press [STOP] to clear the message. Divide the document into sections.

Display	Cause and Solution
"MESSAGE FULL"	<ul style="list-style-type: none"> There is no memory available to record voice messages. Erase unnecessary messages (page 62).
"MODEM ERROR"	<ul style="list-style-type: none"> There is something wrong with the unit's modem. Contact our service personnel.
"NO FAX REPLY"	<ul style="list-style-type: none"> The other party's fax machine is busy or has run out of recording paper. Try again.
"OPEN CABINET CHECK FILM SLACK" "OPEN CABINET CHECK FILM TYPE"	<ul style="list-style-type: none"> Please use genuine Panasonic replacement film (page 11). The ink film is slack. Tighten it (see step 5 on page 17). The fax machine is positioned near appliances such as TVs or speakers which generate an intense magnetic field.
"PAPER JAMMED"	<ul style="list-style-type: none"> A recording paper jam occurred. Clear the jammed paper (page 98).
"PLEASE WAIT"	<ul style="list-style-type: none"> The unit is checking that there is no slack or crease on the ink film. Wait for a moment while the check is completed.
"PHONEBOOK FULL"	<ul style="list-style-type: none"> There is no space to store new items in the base unit phonebook. Erase unnecessary items (page 34).
"POLLING ERROR"	<ul style="list-style-type: none"> The other party's fax machine does not support polling. Check with the other party.
"REDIAL TIME OUT"	<ul style="list-style-type: none"> The other party's fax machine is busy or has run out of recording paper. Try again.
"REMOVE DOCUMENT"	<ul style="list-style-type: none"> The document is jammed. Remove the jammed document (page 101). Press [STOP] to eject the jammed document.
"TRANSMIT ERROR"	<ul style="list-style-type: none"> A transmission error occurred. Try again.
"UNIT OVERHEATED"	<ul style="list-style-type: none"> The unit is too hot. Stop using the unit for a while and let the unit cool down.

13.3 When a function does not work, check here

If you still have difficulties after following the instructions in this section, reset the unit. Disconnect the power cord and turn OFF the handset. Reconnect the power cord and turn ON the handset.

13.3.1 Initial settings

Problem	Cause & Solution
I cannot hear a dial tone.	<ul style="list-style-type: none"> • If you use a splitter to connect the unit, remove the splitter and connect the unit to the wall jack directly. If the unit operates properly, check the splitter. • Disconnect the unit from the telephone line and connect a known working telephone. If the working telephone operates properly, contact our service personnel to have the unit repaired. If the working telephone does not operate properly, contact your telephone company. • The power cord or telephone line cord is not connected. Check the connections. • If you connected the fax machine through a computer modem, connect the fax machine directly to a telephone line jack.
The unit does not ring.	<ul style="list-style-type: none"> • The ringer volume is turned OFF. Adjust it (page 24).

13.3.2 General

Problem	Cause & Solution
The unit displays “CHECK PAPER” even though paper is inserted.	<ul style="list-style-type: none"> • The paper is inserted halfway. Insert it correctly (page 19) and press [START] to clear the message.
The other party complains they only hear a fax tone and cannot talk.	<ul style="list-style-type: none"> • FAX ONLY mode is set. Tell the other party the number is only used for faxes. • Change the receiving mode to TAM/FAX mode (page 55) or TEL mode (page 54).
The [REDIAL] / [PAUSE] button does not function properly.	<ul style="list-style-type: none"> • If this button is pressed during dialling, a pause will be inserted. If pressed immediately after a dial tone is obtained, the last number dialled will be redialled.
The receiving mode does not function properly.	<ul style="list-style-type: none"> • The Distinctive Ring is set (feature #31 on page 58).
During programming, I cannot enter the code or ID number.	<ul style="list-style-type: none"> • All or part of the numbers are the same as another code or ID. Change the number: <ul style="list-style-type: none"> – remote operation ID: feature #11 on page 67. – fax activation code: feature #41 on page 69.
The ink film runs out quickly.	<ul style="list-style-type: none"> • The help printing function, copy function, and reports also use ink film. • Even if there are only a few sentences, every page that comes out of the machine is considered a full page. • Turn OFF the following features: <ul style="list-style-type: none"> – sending report: feature #04 on page 67. – journal report: feature #22 on page 68. – Caller ID list: feature #26 on page 68.
The base unit beeps.	<ul style="list-style-type: none"> • Recording paper/ink film has run out. Press [STOP] to stop the beeps and install paper/ink film.

Problem	Cause & Solution
The speakerphone is not working.	<ul style="list-style-type: none"> • Use the speakerphone in a quiet room. • If you have difficulty hearing the other party, adjust the volume.
I cannot locate a handset.	<ul style="list-style-type: none"> • The called handset is too far from the base unit. • The called handset is in use. Try again later.
Caller information is not displayed.	<ul style="list-style-type: none"> • You have not subscribed to Caller ID service. • The caller requested not to send his/her information. • For Australian users: Your unit is connected to a telephone line with ADSL service. We recommend connecting a filter (contact your ADSL service provider) to the telephone line between the base unit and the telephone line jack. • For New Zealand users: Your unit is connected to a telephone line with ADSL (JetStream) service. We recommend that you contact your ADSL service provider to have an ADSL Splitter installed. We do not recommend the use of generic ADSL filters.
While viewing caller information, the display returns to standby mode.	<ul style="list-style-type: none"> • Do not pause for over 1 minute on the handset or 3 minutes on the base unit while searching.

13.3.3 Handset

Problem	Cause & Solution
The handset does not work.	<ul style="list-style-type: none"> • Make sure that the batteries are installed correctly (page 20). • Fully charge the batteries (page 22). • Clean the charge contacts and charge again (page 22). • Turn the handset power OFF, then ON (page 23). • Check that the power cord is connected properly. • The handset has not been registered to the base unit. Register the handset (page 81). • Re-install the batteries (page 20) and fully charge them.
The handset display is blank.	<ul style="list-style-type: none"> • The handset is not turned ON. Turn the power ON (page 23).
The handset will not turn ON.	<ul style="list-style-type: none"> • Make sure that the batteries are installed correctly (page 20). • Fully charge the batteries (page 22). • Clean the charge contacts and charge again (page 22).
⚡ is flashing.	<ul style="list-style-type: none"> • The handset is not registered to the base unit. Register it (page 81). • The handset is too far from the base unit. Move closer. • The power cord is not connected. Check the connections. • You are using the handset or base unit in an area with high electrical interference. Locate the handset and base unit away from interference sources, such as antenna and mobile phones.
The handset does not ring.	<ul style="list-style-type: none"> • The night mode feature is turned ON. Turn it OFF (page 75). • The ringer volume is turned OFF. Adjust it (page 24).
The batteries should be charging but the battery icon does not change.	<ul style="list-style-type: none"> • Clean the charge contacts and charge again (page 22). • The power cord is disconnected. Plug in the power cord.

Problem	Cause & Solution
<p>A busy tone is heard when [📞] is pressed.</p>	<ul style="list-style-type: none"> • The handset is too far from the base unit. Move closer and try again. • The base unit or another handset is on an outside call. Wait for the other user to complete the call.
<p>Static, sound cuts in/out, fades. Interference from other electrical units.</p>	<ul style="list-style-type: none"> • Move the handset and the base unit away from other electrical appliances. • Move closer to the base unit. • For Australian users: Your unit is connected to a telephone line with ADSL service. We recommend connecting a filter (contact your ADSL service provider) to the telephone line between the base unit and the telephone line jack. • For New Zealand users: Your unit is connected to a telephone line with ADSL (JetStream) service. We recommend that you contact your ADSL service provider to have an ADSL Splitter installed. We do not recommend the use of generic ADSL filters.
<p>Noise is heard during a call.</p>	<ul style="list-style-type: none"> • You are using the handset or base unit in an area with high electrical interference. Locate the handset and base unit away from interference sources, such as antenna and mobile phones.
<p>The handset stops working while being used.</p>	<ul style="list-style-type: none"> • Disconnect the power cord and turn OFF the handset to reset the unit. Connect the power cord, turn ON the handset and try again.
<p>While storing an item in the phonebook or assigning a one touch dial, the handset starts to ring.</p>	<ul style="list-style-type: none"> • To answer a call, press [📞] or [📞]. Storing will be cancelled. Store the name and number again.
<p>I cannot redial by pressing [📞].</p>	<ul style="list-style-type: none"> • If the redialled number was more than 24 digits long, the number will not be redialled. Redial the number manually.
<p>[🔋] flashes or the handset beeps intermittently while it is in use.</p>	<ul style="list-style-type: none"> • Fully charge the batteries (page 22).
<p>I fully charged the batteries, but [🔋] still flashes.</p>	<ul style="list-style-type: none"> • Clean the charge contacts and charge again (page 22). • It is time to replace the batteries (page 20).
<p>I cannot receive documents using the handset.</p>	<ul style="list-style-type: none"> • The memory is full of received documents due to a lack of recording paper or a recording paper jam. Install paper (page 19) or clear the jammed paper (page 98).
<p>I cannot make a call with the handset.</p>	<ul style="list-style-type: none"> • The call bar feature is set. Turn it OFF (page 77). • You dialed a call restricted number. Remove the number from the call restricted list (page 79). • The key lock feature is turned ON. Turn it OFF (page 30).

Problem	Cause & Solution
I cannot register a handset to a base unit.	<ul style="list-style-type: none"> • The maximum number of base units are already registered to the handset. Cancel unused base unit registrations from the handset (page 82). • The maximum number of handsets are already registered to the base unit. Cancel unused handset registrations from the base unit (page 82). • You entered the wrong PIN. If you forget your PIN, consult your nearest Panasonic service centre. • Locate the handset and the base unit away from other electrical appliances.

13.3.4 Fax – sending



Problem	Cause & Solution
I cannot send documents.	<ul style="list-style-type: none"> • The other party's fax machine is busy or has run out of recording paper. Try again. • The other party does not have a fax machine. Check with the other party. • The other party's fax machine failed to answer the fax automatically. Send the fax manually (page 48). • The memory is full of received documents and the quick scan (feature #34 on page 68) is ON. Turn this feature OFF, and send the fax again.
I cannot send a fax overseas.	<ul style="list-style-type: none"> • Use the overseas transmission mode of feature #23 (page 68). • Add two pauses at the end of the telephone number or dial manually.
The other party complains that letters on their received document are distorted or not clear.	<ul style="list-style-type: none"> • If your line has special telephone services such as call waiting, the service may have been activated during fax transmission. Connect the unit to a line that does not have these services. • Another telephone on the same line is off the hook. Hang up the telephone and try again. • Try copying the document. If the copied image is clear, there may be something wrong with the other party's machine. • Adjust the scan contrast using feature #58 (page 70).
The other party complains that black lines, white lines or smudges appear on their received document.	<ul style="list-style-type: none"> • The scanner glass, white plate or rollers are dirty with correction fluid, etc. Clean them (page 102). Please do not insert a document before correction fluid has dried completely.

13.3.5 Fax – receiving

Problem	Cause & Solution
I cannot receive documents.	<ul style="list-style-type: none"> • The ink film is empty. Replace the ink film with a new one (page 18).

Problem	Cause & Solution
<p>I cannot receive documents automatically.</p>	<ul style="list-style-type: none"> ● The receiving mode is set to TEL mode. Change the receiving mode to TAM/FAX mode (page 55) or FAX ONLY mode (page 56). ● The time taken to answer the call is too long. Decrease the number of rings before the unit answers a call (feature #06 on page 67). ● The greeting message is too long. Record a shorter message (page 61).
<p>The display shows “CONNECTING”, but faxes are not received.</p>	<ul style="list-style-type: none"> ● The receiving mode is set to FAX ONLY mode and the incoming call is not a fax. Change the receiving mode to TEL mode (page 54) or TAM/FAX mode (page 55).
<p>A blank sheet is ejected.</p>	<ul style="list-style-type: none"> ● If a blank sheet is ejected after the received document is printed out, the size of the document sent by the other party is as large as, or larger than, the recording paper, or the receiving reduction rate is not programmed correctly. Program the proper rate in feature #36 (page 69). ● The other party placed the document in their fax machine the wrong way. Check with the other party.
<p>The printing quality is poor.</p>	<p>Please do not reuse the ink film! Please use genuine Panasonic replacement film. Refer to page 11 for further details.</p> <ul style="list-style-type: none"> ● The thermal head is dirty. Clean it (page 103). ● Some paper has instructions recommending which side to print on. Try turning the paper over. ● You may have used paper with a cotton and/or fibre content that is over 20%, such as letterhead or resume paper. ● If documents can be copied properly, the unit is working normally. The other party may have sent a faint document or there may be something wrong with the other party's machine. Ask them to send a clearer copy of the document or to check their fax machine.
<p>The other party complains that they cannot send a document.</p>	<ul style="list-style-type: none"> ● The receiving mode is set to TEL mode. Receive the document manually (page 53) or change the receiving mode to TAM/FAX mode (page 55) or FAX ONLY mode (page 56). ● The memory is full of received documents due to a lack of recording paper, a lack of ink film or a recording paper jam. Install paper (page 19) or clear the jammed paper (page 98).
<p>I cannot select the desired receiving mode.</p>	<ul style="list-style-type: none"> ● If you want to set TAM/FAX or FAX ONLY mode, set the desired mode using feature #77 (page 70), and press [AUTO ANSWER] repeatedly to select the desired mode. ● If you want to set TEL mode, press [AUTO ANSWER] repeatedly to select TEL mode. ● The Distinctive Ring is set (feature #31 on page 58).
<p>I cannot receive documents using the handset.</p>	<ul style="list-style-type: none"> ● The memory is full of received documents due to a lack of recording paper, a lack of ink film or a recording paper jam. Install paper (page 19) or clear the jammed paper (page 98).
<p>When an extension telephone is connected, I cannot receive documents by pressing [*][#][9].</p>	<ul style="list-style-type: none"> ● You must set remote fax activation to ON (feature #41 on page 69) beforehand. ● Press [*][#][9] firmly. ● The memory is full of received documents due to a lack of recording paper, a lack of ink film or a recording paper jam. Install paper (page 19) or clear the jammed paper (page 98).

13.3.6 Copying

Problem	Cause & Solution
The unit will not make a copy.	<ul style="list-style-type: none"> The ink film is empty. Replace the ink film with a new one (page 18). You cannot make a copy during programming. You cannot make a copy during a telephone conversation.
A black line, a white line or smudge appears on the copied document.	<ul style="list-style-type: none"> The scanner glass, white plate or rollers are dirty with correction fluid, etc. Clean them (page 102). Please do not insert a document before correction fluid has dried completely.
The copied image is distorted.	<ul style="list-style-type: none"> Adjust the width of the document guides to fit the actual size of the document.
The printing quality is poor.	<p>Please do not reuse the ink film! Please use genuine Panasonic replacement film. Refer to page 11 for further details.</p> <div style="display: flex; justify-content: space-around; align-items: center;"> <div style="text-align: center;"> <p>Original</p>  </div> <div style="text-align: center;"> <p>Copy</p>  </div> </div> <ul style="list-style-type: none"> Some paper has instructions recommending which side to print on. Try turning the paper over. You may have used paper with a cotton and/or fibre content that is over 20%, such as letterhead or resume paper. The thermal head is dirty. Clean it (page 103).

13.3.7 Answering machine

Problem	Cause & Solution
The answering machine is turned ON, but caller messages are not recorded.	<ul style="list-style-type: none"> The message memory is full. Erase unnecessary messages (page 62).
I cannot retrieve recorded messages from a remote location.	<ul style="list-style-type: none"> Activate the remote operation feature by setting the remote operation ID beforehand (feature #11 on page 67). Press the remote operation ID correctly and firmly (page 64). The unit is not in TAM/FAX mode. Change to TAM/FAX mode (page 55). You are using a pulse telephone. Try again using a touch tone phone.
The other party complains that they cannot leave a voice message.	<ul style="list-style-type: none"> The memory is full. Erase unnecessary messages (page 62).
While recording a greeting message or listening to messages, the unit rings and recording stops.	<ul style="list-style-type: none"> A call is being received. Answer the call and try again later.

13.3.8 SMS (KX-FC235AL only)

Problem	Cause & Solution
<p>I cannot send or receive SMS messages.</p>	<ul style="list-style-type: none"> ● You have not subscribed to the appropriate service. Consult your service provider. ● The SMS message centre number(s) are not stored or are incorrect. Store the correct numbers (page 41). ● You may request that your service provider block your phone number when making phone calls. In order to send messages, you need to add "1832" to the beginning of the Message Centre 1 number (page 41). Note that by doing so, your phone number will be sent along with your SMS messages. ● Message transmission was interrupted. Wait until the message has been sent before using other telephone functions. ● SMS message memory is full. Erase unnecessary message in the receive and send lists (page 43, 44).
<p>"FD" is displayed.</p>	<ul style="list-style-type: none"> ● The unit could not connect to the SMS message centre. Confirm that the correct SMS message centre numbers are stored (page 41). Confirm that SMS is turned ON (page 41).
<p>"FE" is displayed.</p>	<ul style="list-style-type: none"> ● An error occurred while sending the message. Try again.
<p>"E0" is displayed.</p>	<ul style="list-style-type: none"> ● Your telephone number is permanently withheld or you have not subscribed to the appropriate service. Consult your service provider.
<p>✓ is not displayed after you display a message. An error code ("FD", "FE", or "E0") is displayed.</p>	<ul style="list-style-type: none"> ● When an error code is displayed, ✓ will not be displayed even if you have displayed the message.

13.3.9 If a power failure occurs

- The unit will not function.
- The unit is not designed for making emergency telephone calls when the power fails. Alternative arrangements should be made for access to emergency services.
- Fax transmission and reception will be interrupted.
- If delayed transmission (feature #25 on page 68) is programmed and power failure prevents the document from being sent at the set time, the document will be sent after power is restored.
- If any fax documents are stored in the memory, they will be lost. When power is restored, a power down report will be printed stating which documents in memory have been erased.

Note for Australian users:

- Panasonic Australia operates a toll free Customer Care Centre. Please visit the website for assistance at <http://www.panasonic.com.au> or please call 132600.

Note for New Zealand users:

- Panasonic New Zealand operates a Customer Support Centre. Please call (09) 2720178 for assistance.

13.4 Recording paper jams

13.4.1 When the recording paper has jammed in the unit

The base unit display will show the following.

PAPER JAMMED

- 1 Open the front cover by pulling up the centre part.

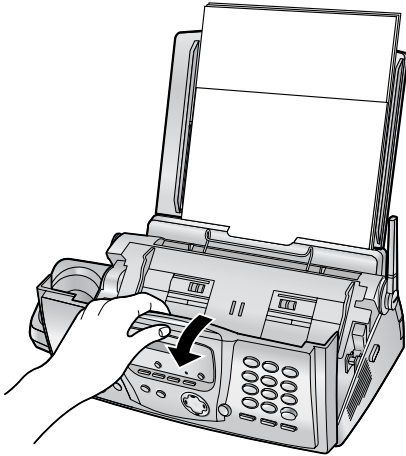

- 2 Release the back cover by pushing the green button (1).
 - You can also release the back cover by pushing in the green lever (2).

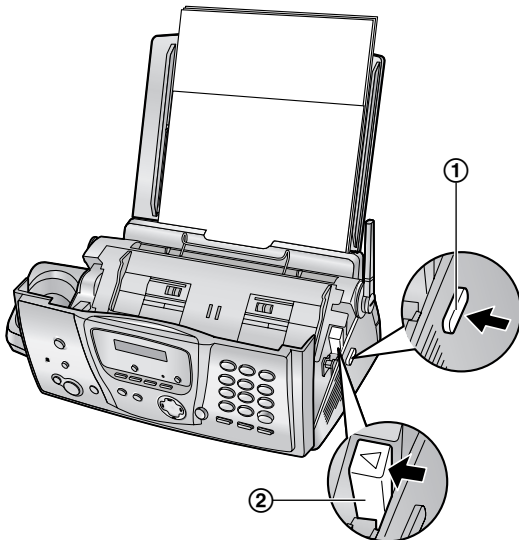

- 3 Open the back cover.

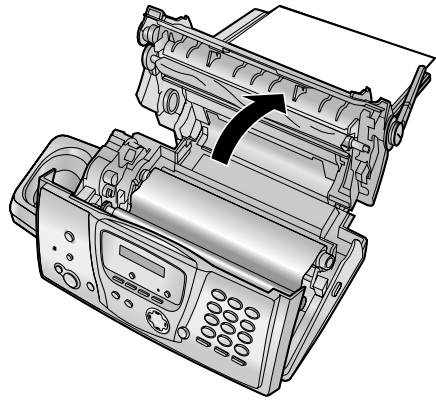

- 4 Remove the jammed recording paper (1).

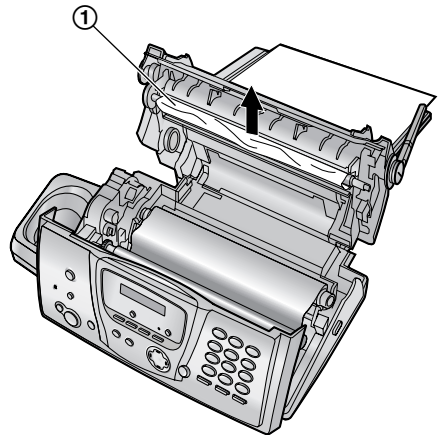

- 5 Turn the gear of the blue core (①) in the direction of the arrow until the ink film is tight (②).

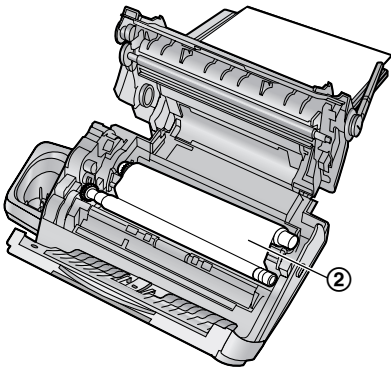
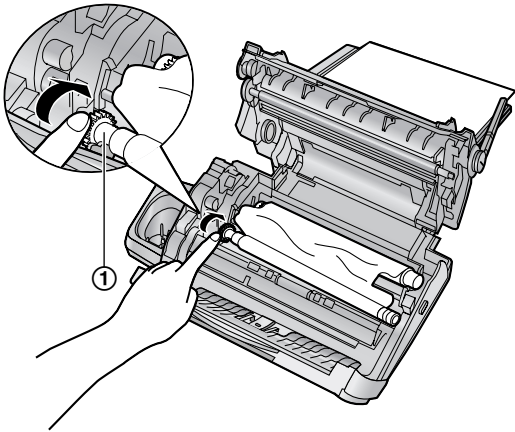

- The ink film is reversed.

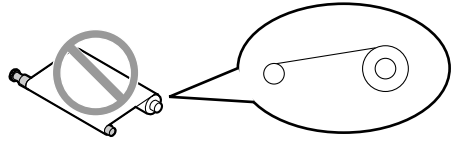

- The ink film is slack or creased.



- 6 Close the back cover securely by pushing down on the notched area at both ends (①).

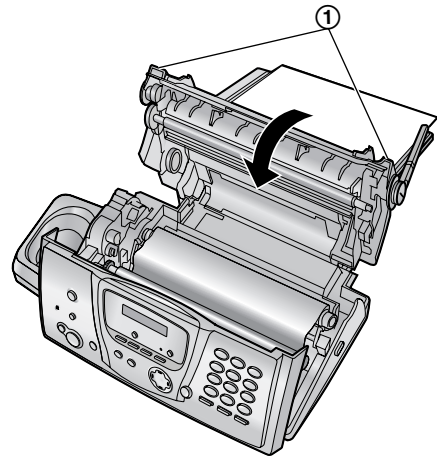

- 7 Close the front cover securely.

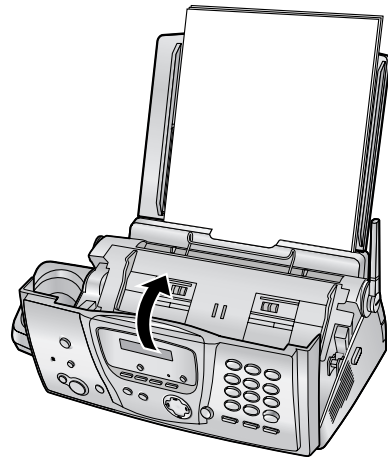

Correct

- The ink film is wrapped around the blue core (③) at least once.

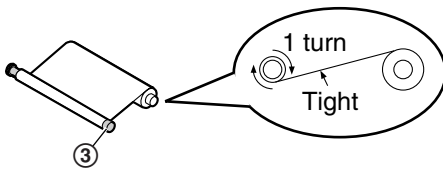

Incorrect

- The ink film is not wrapped around the blue core (④).

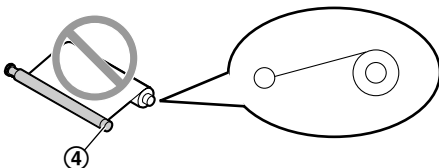

- 8 Remove the recording paper and straighten. Pull the tension plate forward (①) and insert the paper. Then push the tension plate back.



13.4.2 When the recording paper was not fed into the unit properly

The base unit display will show the following.

CHECK PAPER

Remove the recording paper and straighten. Pull the tension plate forward (①) and insert the paper. Push the tension plate back, then press **[START]** to clear the message.

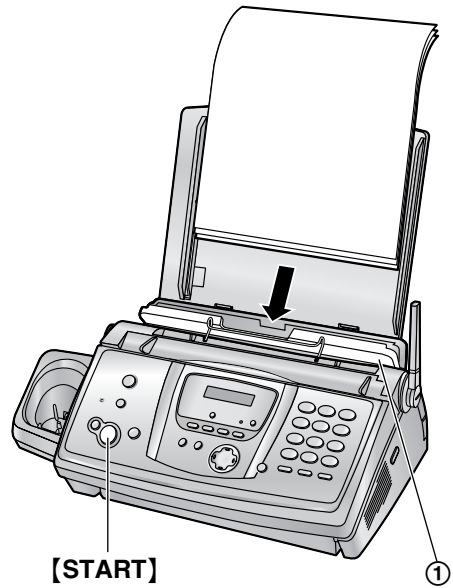

13.5 Document jams – sending

- 1 Open the front cover by pulling up the centre part. Remove the jammed document carefully (①).

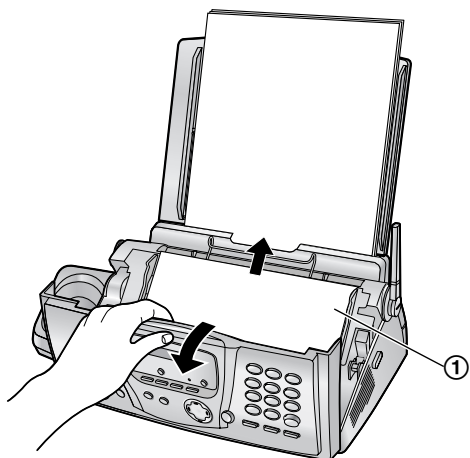
**Note:**

- Do not pull out the jammed paper forcibly before opening the front cover.



- 2 Close the front cover securely.

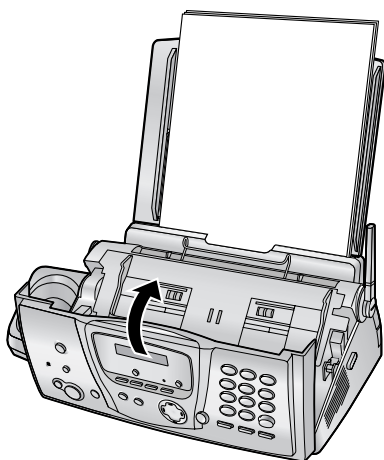

13.6 Document feeder / scanner glass cleaning

Clean the document feeder/scanner glass when:

- Documents frequently misfeed.
- Smudges or black/white lines appear on the original document when sending or copying.

- 1 Disconnect the power cord and the telephone line cord.
- 2 Open the front cover by pulling up the centre part.



- 3 Clean the document feeder rollers (①) and rubber flap (②) with a cloth moistened with isopropyl rubbing alcohol, and let all parts dry thoroughly. Clean the scanner glass (③) with a soft, dry cloth.

Caution:

- Do not use paper products, such as paper towels or tissues.

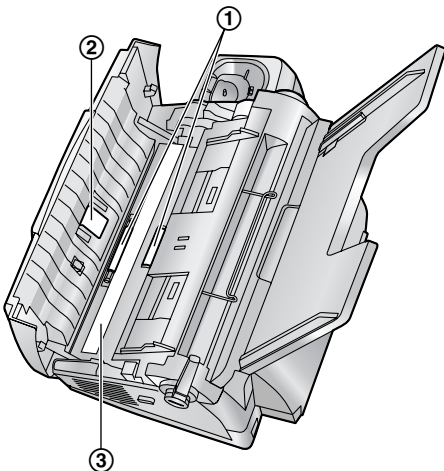

- 4 Close the front cover securely.

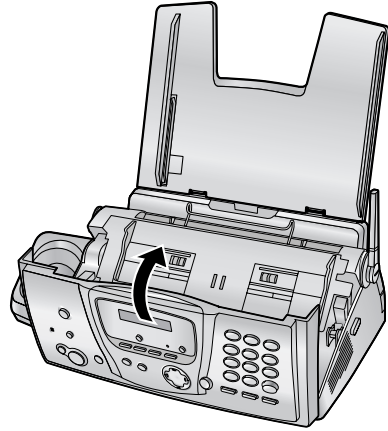

- 5 Connect the power cord and the telephone line cord.

13.7 Thermal head cleaning

If smudges or black/white lines appear on a copied/received document, check whether there is dust on the thermal head. Clean the thermal head to remove the dust.

- 1 Disconnect the power cord and the telephone line cord.
- 2 Open the front cover by pulling up the centre part.

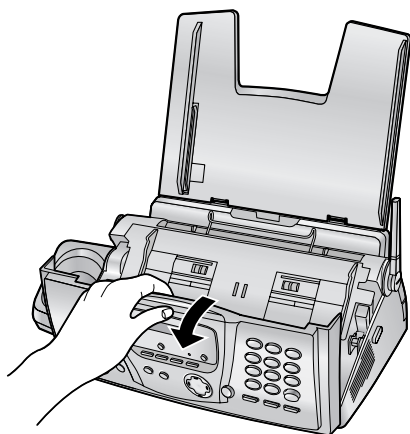

- 3 Release the back cover by pushing the green button (①).
 - You can also release the back cover by pushing in the green lever (②).

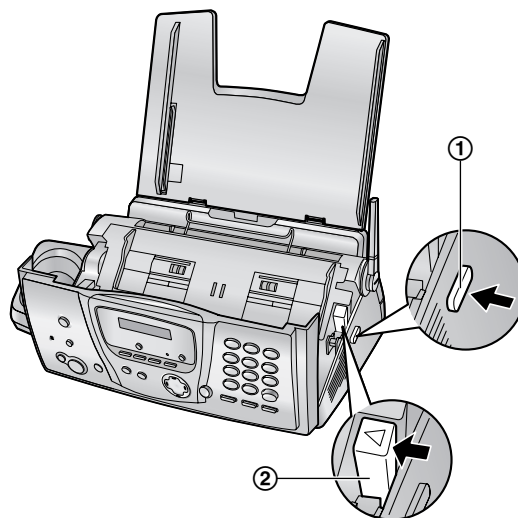

- 4 Open the back cover.

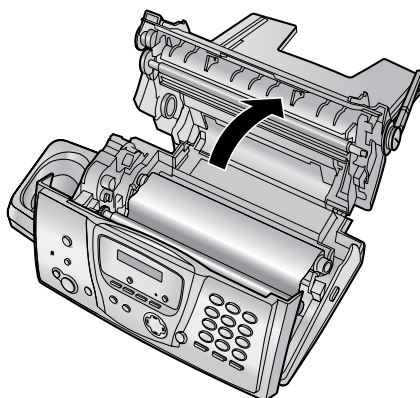

- 5 Remove the ink film (①).

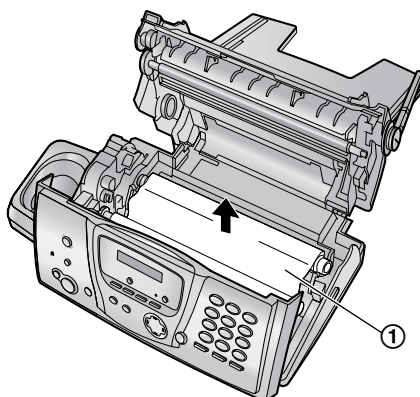

13. Help

- 6** Clean the thermal head (①) with a cloth moistened with isopropyl rubbing alcohol, and let it dry thoroughly.

Caution:

- To prevent a malfunction due to static electricity, do not use a dry cloth and do not touch the thermal head directly.

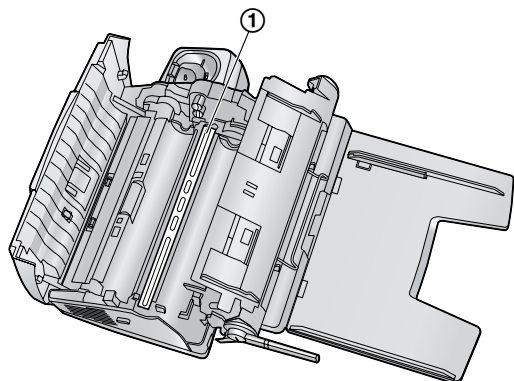

- 7** Reinstall the ink film and close the covers (see steps 4 to 7 on page 16).
- 8** Connect the power cord and the telephone line cord.

14.1 Reference lists and reports (Base unit only)

You can print out the following lists and reports for your reference.

“SETUP LIST”:

provides you with the current settings of the base unit programming features (page 67 to page 70).

“FAX NO. LIST”:

provides you with names and numbers which are stored in the base unit phonebook.

“JOURNAL REPORT”:

keeps records of fax transmission and reception. This report can be printed automatically after every 30 fax communications (feature #22 on page 68).

“PRINTER TEST”:

allows you to check the print quality of your unit. If the test print has a smudge, or blurred points or lines, clean the thermal head (page 103).

“BROADCAST LIST”:

provides you with names and numbers which are stored in the broadcast memory (page 50).

“CALLER ID LIST”:

keeps records of the last 30 different callers of the base unit after subscribing to a Caller ID service. To print automatically after every 30 callers, activate feature #26 (page 68).

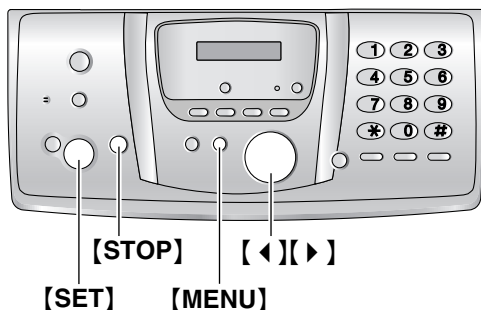

- 1 Press **[MENU]** repeatedly to display “PRINT REPORT”.
- 2 Press **[◀]** or **[▶]** repeatedly to display the desired item.
- 3 Press **[SET]** to start printing.
 - To stop printing, press **[STOP]** 2 times.
- 4 Press **[MENU]**.

14.2 Specifications

14.2.1 Base unit

■ Applicable lines:

Public Switched Telephone Network

■ Document size:

Max. 216 mm in width, Max. 600 mm in length

■ Effective scanning width:

208 mm

■ Effective printing width:

A4: 202 mm

■ Transmission time*¹:

Approx. 8 s/page (ECM-MMR)*²

■ Scanning density:

Horizontal: 8 pels/mm

Vertical: 3.85 lines/mm – in standard resolution,

7.7 lines/mm – in fine/photo resolution,

15.4 lines/mm – in super fine resolution

■ Photo resolution:

64-level

■ Scanner type:

Contact Image Sensor

■ Printer type:

Thermal Transfer on plain paper

■ Data compression system:

Modified Huffman (MH), Modified READ (MR),

Modified Modified READ (MMR)

■ Modem speed:

14,400 / 12,000 / 9,600 / 7,200 / 4,800 / 2,400

bps; Automatic Fallback

■ Operating environment:

5 °C – 35 °C, 20 % – 80 % RH (Relative Humidity)

■ Dimensions:

Approx. height 128 mm × width 389 mm × depth 242 mm

■ Mass (Weight):

Approx. 3.4 kg

■ Power consumption:

Standby: Approx. 6 W

Transmission: Approx. 16 W

Reception: Approx. 50 W (When receiving a 20 % black document)

Copy: Approx. 50 W (When copying a 20 % black document)

Maximum: Approx. 130 W (When copying a 100 % black document)

■ Power supply:

220 V – 240 V AC, 50/60 Hz

■ Fax memory capacity*³:

Approx. 25 pages of memory transmission

Approx. 28 pages of memory reception

(Based on the ITU-T No. 1 Test Chart in standard resolution, without using the Error Correction Mode.)

■ Voice memory capacity*⁴:

Approx. 18 minutes of recording time including greeting messages

■ Copy memory capacity:

Approx. 10 pages (Based on the ITU-T No. 1 Test Chart in fine resolution.)

*1 Transmission speed depends upon the contents of the pages, resolution, telephone line conditions and capability of the other party's machine.

*2 Transmission speed is based upon the ITU-T No. 1 Test Chart. If the capability of the other party's machine is inferior to your unit, the transmission time may be longer.

*3 If an error occurs during fax reception, such as a paper jam or if the recording paper runs out, the fax and subsequent faxes will be retained in memory.

*4 Recording time may be reduced by the calling party's background noise.

ITU-T No. 1 Test Chart

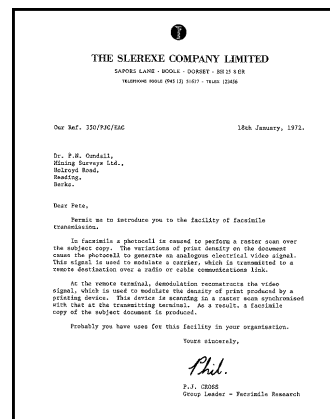

Recording paper specifications

Recording paper size: A4: 210 mm × 297 mm

Recording paper weight: 64 g/m² to 80 g/m²

Note for recording paper:

- Do not use the following types of paper:
 - Paper with a cotton and/or fibre content that is over 20 %, such as letterhead paper or paper used for resumes
 - Extremely smooth or shiny paper, or paper that is highly textured
 - Coated, damaged or wrinkled paper

- Paper with foreign objects attached, such as tabs or staples
- Paper which has dust, lint or oil stains
- Paper that will melt, vaporize, discolour, scorch or emit dangerous fumes near 200 °C, such as vellum paper. These materials may transfer onto the fusing roller and cause damage.
- Moist paper
- Some paper only accepts print on one side. Try using the other side of the paper if you are not happy with the print quality or if misfeeding occurs.
- For proper paper feeding and best print quality, we recommend using long-grained paper.
- Do not use paper of different types or thickness at the same time. This may cause a paper jam.
- Avoid double-sided printing.
- Do not use paper printed from this unit for double-sided printing with other copiers or printers. This may cause a paper jam.
- To avoid curling, do not open paper packs until you are ready to use the paper. Store unused paper in the original packaging, in a cool and dry location.

14.2.2 Handset

■ **Standard:**

GAP (Generic Access Profile)

■ **Number of channels:**

120 Duplex Channels

■ **Frequency range:**

1.88 GHz to 1.9 GHz

■ **Duplex procedure:**

TDMA (Time Division Multiple Access)

■ **Channel spacing:**

1,728 kHz

■ **Bit rate:**

1,152 kbit/s

■ **Modulation:**

GFSK

■ **RF transmission power:**

Approx. 250 mW

■ **Operating environment:**

5 °C – 40 °C, 20 % – 80 % RH (Relative Humidity)

■ **Dimensions:**

Approx. height 148 mm × width 48 mm × depth 32 mm

■ **Mass (Weight):**

Approx. 130 g

Note:

- Design and specifications are subject to change without notice.
- The pictures and illustrations in these instructions may vary slightly from the actual product.

15.1 Index

- # #01 Date and time: 26
- #02 Your logo: 26
- #03 Your fax number: 28
- #04 Sending report: 49, 67
- #06 FAX ring setting: 67
- #06 TAM ring setting: 55, 67
- #10 Message recording time: 67
- #11 Remote operation ID: 67
- #17 External ring tone: 67
- #22 Automatic journal report: 49, 68
- #23 Overseas mode: 68
- #25 Delayed transmission: 68
- #26 Automatic Caller ID list: 68
- #31 Distinctive Ring: 58
- #34 Quick scan: 48, 59, 68
- #36 Receiving reduction: 69
- #39 Display contrast: 69
- #41 Fax activation code: 69
- #42 Message alert: 69
- #43 Recording time alert: 69
- #44 Memory reception alert: 69
- #46 Friendly reception: 69
- #47 Voice guidance: 69
- #53 SMS (KX-FC235AL only): 41
- #54 Greeting recording time: 61, 70
- #58 Scan contrast: 70
- #67 Incoming message monitor: 70
- #68 ECM selection: 70
- #76 Connecting tone: 70
- #77 Auto answer: 70
- #80 Set default: 70
- A** Accessories: 10
 - Paper tray: 18
- Advanced features: 68
- Alarm: 75
- Auto answer setting: 70
- Auto talk feature: 31, 77
- B** Base unit
 - Additional base units: 81
 - Cancelling: 82
 - PIN: 80
 - Selecting: 81
- Base unit phonebook
 - Editing: 34
 - Erasing: 34
 - Making a phone call: 34
 - Sending faxes: 50
 - Storing: 34
- Basic features: 67
- Battery
 - Charge: 22
 - Installation: 20
 - Life: 22
 - Replacement: 20
- Broadcast transmission: 50
- Button description
 - Base unit: 12
 - Handset: 13
- C** Call bar: 77
- Caller ID: 35
 - Calling back: 37
 - Storing: 39
- Caller ID list: 36, 68, 105
- Call minder: 40
- Call restriction: 79
- Category: 32
- Chain dial: 33
- Character entry
 - Base unit: 26
 - Handset: 85
 - SMS (KX-FC235AL only): 46
- Cleaning: 102, 103
- Conference calls: 83
- Connecting tone: 70
- Connections: 21
- Copy: 59
 - Collation: 60
 - Enlarge: 59
 - Reduce: 59
- D** Date and time: 25
- Delayed transmission: 68
- Display (Base unit)
 - Contrast: 69
 - Error messages: 88
- Display (Handset)
 - Contrast: 77
 - Description: 14
 - Language: 76
 - Standby mode: 76
- Distinctive Ring: 58
- Document size: 49
- E** ECM selection: 70
- Emergency call: 79
- Error messages: 87
- Extension telephone: 54
- F** FaxAbility: 58
- Fax activation code: 69
- Fax number: 28

- FAX ONLY mode: 52, 56
 Fax Stream Duet: 58
 Friendly reception: 69
- G** Greeting message: 61
- H** Handset
 Additional handsets: 81
 Cancelling: 82
 Locator: 82
 PIN: 77
 Registration: 81
 Handset phonebook
 Copying: 84
 Editing: 32
 Erasing: 33
 Making a phone call: 32
 Storing: 31
 Help: 23
- I** Incoming message monitor: 70
 Ink film
 Installing: 16
 Replacing: 18
 Intercom: 83
- J** Jams
 Document: 101
 Recording paper: 98
 Journal report: 49, 68
 Junk fax prohibitor: 57
- K** Key lock: 30
 Key tone: 77
- L** Language: 76
 LetterWise (KX-FC235AL only): 46, 77, 85
 Listening to recorded messages: 62
 From a remote location: 64
 Logo: 26
- M** Memory reception alert: 69
 Message alert: 69
 Message recording time: 67
- N** Navigator: 12, 13
 Night mode: 75
- O** One touch dial: 33
 Overseas mode: 68
- P** Pause length: 78
 Phonebook
 Base unit: 34
 Handset: 31
 PIN: 77, 80
 Polling: 56
 Power failure: 97
- Power ON/OFF (Handset): 23
 Programming
 Base unit programming: 66
 Handset programming: 73
- Q** Quick scan: 48, 59, 68
- R** Recall: 78
 Receiving faxes
 Automatically: 55
 Manually: 54
 Receiving reduction: 69
 Recording
 Greeting message: 61
 Memo message: 62
 Recording paper: 19, 106
 Recording time alert: 69
 Recording time for TAM/FAX greeting message: 61, 70
 Redialling
 Base unit: 30, 48, 50
 Handset: 29
 Redial list: 29
 Registration: 81
 Remote operation: 64
 Remote operation ID: 67
 Repeater: 82
 Reports
 Broadcast programming: 105
 Broadcast sending: 51
 Caller ID list: 36, 68, 105
 Fax number: 105
 Journal: 49, 68, 105
 Power down: 97
 Printer test: 105
 Sending: 49, 67
 Setup: 105
- Reset
 Base unit: 70
 Handset: 77, 80
 Resolution: 48, 59
 Ringer volume
 Base unit: 24
 Handset: 24
 Ring setting
 FAX ONLY: 67
 TAM/FAX: 67
 Ring tone
 Base unit: 67
 Handset: 75
- S** Scan contrast: 70
 Sending faxes
 Base unit phonebook: 50

15. Index

Broadcast: 51

From memory: 48

Manually: 48

Sending report: 49, 67

SMS feature (KX-FC235AL only): 41

Storing

Broadcast: 50

One touch dial: 33

Phonebook: 31, 34

T TAM/FAX mode: 52, 55

TEL mode: 53, 54

Toll saver: 55

Transferring calls: 83

V Voice enhancer: 29

Voice guidance: 69

Voice mail: 40

Voice time/day stamp: 62

Volume

Base unit: 24

Handset: 24

Notes



Sales Department:

Panasonic Australia Pty. Limited

Austlink Corporate Park, 1 Garigal Road, Belrose, NSW 2085,
Australia

Panasonic New Zealand Limited

350 Te Irirangi Drive, East Tamaki, Private Bag 14911, Panmure,
Auckland, New Zealand

Manufacturer:

Panasonic Communications (Malaysia) Sdn. Bhd.

PLO No.1, Kawasan Perindustrian Senai, KB No. 104, 81400 Senai, Negeri Johor Darul Ta'zim, Malaysia

Global web site:

<http://www.panasonic.co.jp/global/>

Copyright:

- This material is copyrighted by Panasonic Communications Co., Ltd., and may be reproduced for internal use only. All other reproduction, in whole or in part, is prohibited without the written consent of Panasonic Communications Co., Ltd.

© 2005 Panasonic Communications Co., Ltd. All Rights Reserved.

Free Manuals Download Website

<http://myh66.com>

<http://usermanuals.us>

<http://www.somanuals.com>

<http://www.4manuals.cc>

<http://www.manual-lib.com>

<http://www.404manual.com>

<http://www.luxmanual.com>

<http://aubethermostatmanual.com>

Golf course search by state

<http://golfingnear.com>

Email search by domain

<http://emailbydomain.com>

Auto manuals search

<http://auto.somanuals.com>

TV manuals search

<http://tv.somanuals.com>