

Panasonic

High Speed Laser Fax and Copier

Operating Instructions

Model No. **KX-FL511**



FOR FAX ADVANTAGE ASSISTANCE:

— PHONE CALL

1-800-HELP-FAX (1-800-435-7329)

— E-MAIL TO

consumerproducts@panasonic.com
for customers in the U.S.A. or Puerto Rico

— REFER TO

www.panasonic.com

for customers in the U.S.A. or Puerto Rico

Please read these Operating Instructions before using the unit and save for future reference.

This model is designed to be used only in the U.S.A.

How to use the operating instructions

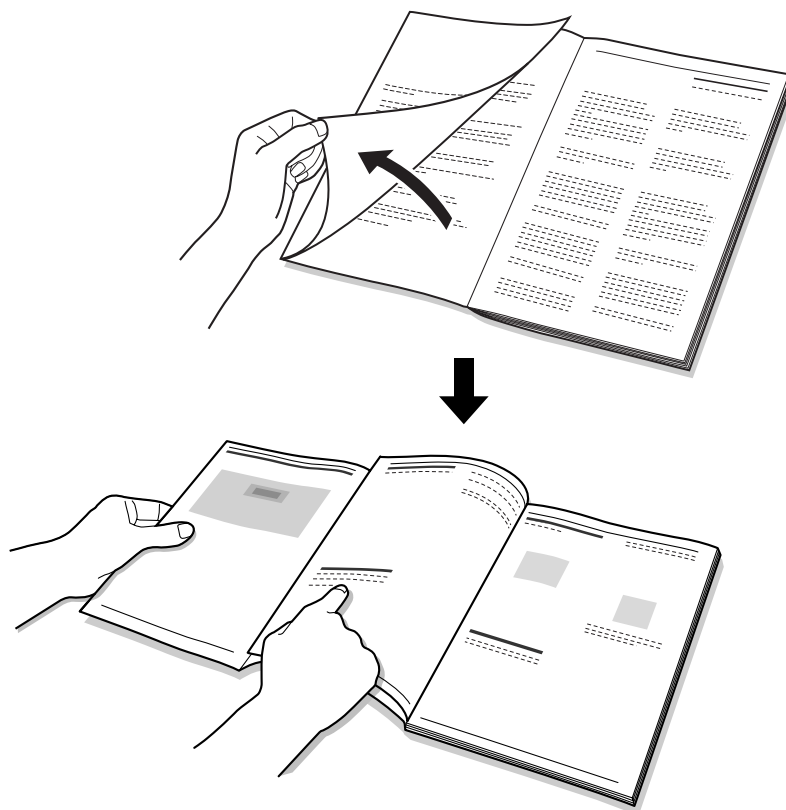

When following operating instructions, always keep the front cover page (next page) open so that you will find easy reference to the buttons.

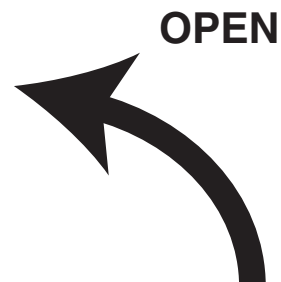

Location of controls

Please keep this page open when following operating instructions.

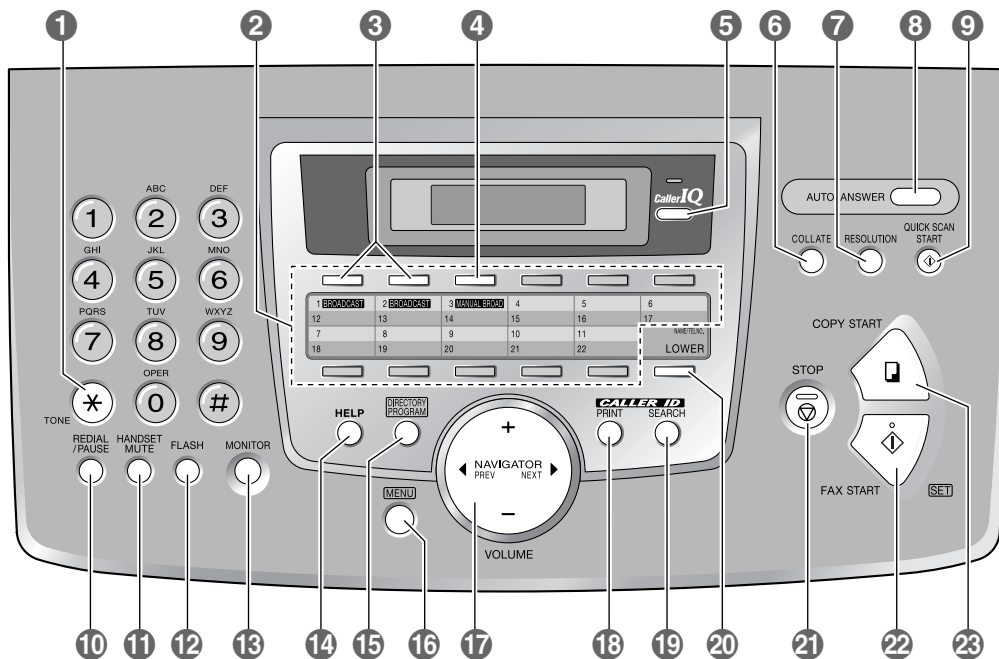

Keys

AUTO ANSWER 8

BROADCAST 3

CALLER ID PRINT 18

CALLER ID SEARCH 19

CALLER IQ 5

COLLATE 6

COPY START 23

DIRECTORY PROGRAM 15

FAX START 22

FLASH 12

HANDSET MUTE 11

HELP 14

LOWER 20

MANUAL BROAD 4

MENU 16

MONITOR 13

NAME/TEL NO. 20

NAVIGATOR 17

QUICK SCAN START 9

REDIAL/PAUSE 10

RESOLUTION 7

SET 22

Station keys 2

STOP 21

TONE 1

VOLUME 17

Thank you for purchasing a Panasonic fax machine.

Things you should keep a record of

┌-----┐
| Attach your sales receipt here. |
└-----┘

For your future reference

Date of purchase _____

Serial number _____

(found on the rear of the unit)

Dealer's name and address _____

Dealer's telephone number _____

Caution:

- The Telephone Consumer Protection Act of 1991 makes it unlawful for any person to use a computer or other electronic device, including fax machines, to send any message unless such message clearly contains in a margin at the top or bottom of each transmitted page or on the first page of the transmission, the date and time it is sent and an identification of the business or other entity, or other individual sending the message and the telephone number of the sending machine or such business, other entity, or individual. (The telephone number provided may not be a 900 number or any other number for which charges exceed local or long-distance transmission charges.)
In order to program this information into your fax machine, you should complete the instructions on page 28 to page 30.
- Do not rub or use an eraser on the printed side of recording paper, as the print may smear.

Energy Star:

- As an ENERGY STAR® Partner, Panasonic has determined that this product meets the ENERGY STAR guidelines for energy efficiency.
ENERGY STAR is a U.S. registered mark.



Trademarks:

- openLCR and openLCR.com are the trademarks of openLCR.com, Inc.
- All other trademarks identified herein are the property of their respective owners.

Copyright:

- This manual is copyrighted by Panasonic Communications Co., Ltd. (PCC) and its licensee. Under the copyright laws, this manual may not be reproduced in any form, in whole or part, without the prior written consent of PCC and its licensee.

© Panasonic Communications Co., Ltd. 2003

Important safety instructions

When using this unit, basic safety precautions should always be followed to reduce the risk of fire, electric shock, or personal injury.

1. Read and understand all instructions.
2. Follow all warnings and instructions marked on this unit.
3. Unplug this unit from power outlets before cleaning. Do not use liquid or aerosol cleaners. Use a damp cloth for cleaning.
4. Do not use this unit near water, for example near a bathtub, wash bowl, kitchen sink, etc.
5. Place the unit securely on a stable surface. Serious damage and/or injury may result if the unit falls.
6. Do not cover slots and openings on the unit. They are provided for ventilation and protection against overheating. Never place the unit near radiators, or in a place where proper ventilation is not provided.
7. Use only the power source marked on the unit. If you are not sure of the type of power supplied to your home, consult your dealer or local power company.
8. For safety purposes this unit is equipped with a grounded plug. If you do not have this type of outlet, please have one installed. Do not defeat this safety feature by tampering with the plug.
9. Do not place objects on the power cord. Install the unit where no one can step or trip on the cord.
10. Do not overload power outlets and extension cords. This can result in the risk of fire or electric shock.
11. Never push any objects through slots in this unit. This may result in the risk of fire or electric shock. Never spill any liquid on the unit.
12. To reduce the risk of electric shock, do not disassemble this unit. Take the unit to an authorized service center when service is required. Opening or removing covers may expose you to dangerous voltages or other risks. Incorrect reassembly can cause electric shock when the unit is subsequently used.
13. Unplug this unit from power outlets and refer servicing to an authorized service center when the following conditions occur:
 - A. When the power cord is damaged or frayed.
 - B. If liquid has been spilled into the unit.
 - C. If the unit has been exposed to rain or water.
 - D. If the unit does not work normally by following the operating instructions. Adjust only controls covered by the operating instructions. Improper adjustment may require extensive work by an authorized service center.
 - E. If the unit has been dropped or physically damaged.
 - F. If the unit exhibits a distinct change in performance.
14. During thunderstorms, avoid using telephones except cordless types. There may be a remote risk of an electric shock from lightning.
15. Do not use this unit to report a gas leak, when in the vicinity of the leak.

SAVE THESE INSTRUCTIONS

INSTALLATION:

- After moving the unit from cold areas to warmer areas, let the unit adjust to the warmer temperature and do not connect the unit for about 30 minutes. If the unit is connected too soon after a sudden climate change, condensation may form inside the unit causing malfunction.
- Never install telephone wiring during a lightning storm.
- Never install telephone jacks in wet locations unless the jack is specifically designed for wet locations.
- Never touch uninsulated telephone wires or terminals unless the telephone line has been disconnected at the network interface.
- Use caution when installing or modifying telephone lines.

WARNING:

- To prevent the risk of fire or electrical shock, do not expose this product to rain or any type of moisture.

OTHER INFORMATION:

- Keep the unit away from electrical noise generating devices, such as fluorescent lamps and motors.
- The unit should be kept free from dust, high temperature and vibration.
- The unit should not be exposed to direct sunlight.
- Do not place heavy objects on top of this unit.
- Do not touch the plug with wet hands.

CAUTION:

Laser radiation

- The printer of this unit utilizes a laser. Use of controls or adjustments or performance of procedures other than those specified herein may result in hazardous radiation exposure.

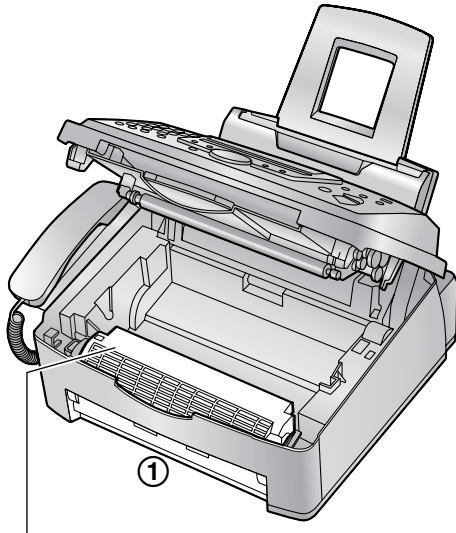

Fuser unit

Fuser unit

- The fuser unit gets hot. Do not touch it.
- During or immediately after printing, the area near the recording paper exit (①) also gets warm. This is normal.

Toner cartridge

- Be careful of the following when you handle the toner cartridge:
 - Do not leave the toner cartridge out of the protection bag for a long time. It will decrease the toner life.
 - If you ingest any toner, drink several glasses of water to dilute your stomach contents, and seek immediate medical treatment.

- If any toner comes into contact with your eyes, flush them thoroughly with water, and seek medical treatment.
- If any toner comes into contact with your skin, wash the area thoroughly with soap and water.

Drum unit

- Read the instructions on page 10 before you begin installation of the drum unit. After you have read them, open the drum unit protection bag. The drum unit contains a photosensitive drum. Exposing it to light may damage the drum. Once you have opened the protection bag:
 - Do not expose the drum unit to light for more than 5 minutes.
 - Do not touch or scratch the green drum surface.
 - Do not place the drum unit near dust or dirt, or in a high humidity area.
 - Do not expose the drum unit to direct sunlight.

1. Introduction and Installation

Accessories

- 1.1 Included accessories 7
- 1.2 Accessory information 8

Finding the Controls

- 1.3 Description of buttons 8
- 1.4 Overview 9

Installation

- 1.5 Toner cartridge and drum unit 10
- 1.6 Paper tray 12
- 1.7 Paper stacker 12
- 1.8 Document stacker 13
- 1.9 Handset cord 13
- 1.10 Recording paper 13

2. Preparation

Connections and Setup

- 2.1 Selecting the way to use your fax machine 15
- 2.2 Case 1: FAX ONLY 16
- 2.3 Case 2a: Distinctive Ring (1 phone line with 2 or more phone numbers) 17
- 2.4 Case 2b: Distinctive Ring (using with voice mail service) 19
- 2.5 Case 3: EXT. TAM 21
- 2.6 Case 4: TEL ONLY 23
- 2.7 Case 5: FAX with PC MODEM (one phone number) 25

Help Button

- 2.8 Help function 27

Volume

- 2.9 Adjusting volume 27

Initial Programming

- 2.10 Date and time 28
- 2.11 Your logo 29
- 2.12 Your fax number 30

3. Telephone

Automatic Dialing

- 3.1 Storing names and telephone numbers into one-touch dial 31
- 3.2 Storing names and telephone numbers into the navigator directory 31
- 3.3 Editing a stored entry 32
- 3.4 Erasing a stored entry 32
- 3.5 Making a phone call using one-touch dial and navigator directory 32

Caller ID

- 3.6 Caller ID service 33
- 3.7 Viewing and calling back using caller

- information 33
- 3.8 Printing the Caller ID list 34
- 3.9 Erasing caller information 34
- 3.10 Storing caller information 34

4. Fax

Sending Faxes

- 4.1 Sending a fax manually 36
- 4.2 Documents you can send 37
- 4.3 Sending a fax using one touch dial and navigator directory 37
- 4.4 Broadcast transmission 38

Receiving Faxes

- 4.5 Receiving a fax manually 39
- 4.6 Receiving a fax automatically 40
- 4.7 Junk fax prohibitor (preventing fax reception from undesired callers) 40
- 4.8 Programming undesired callers 41

5. Distinctive Ring

Distinctive Ring

- 5.1 Distinctive Ring service from your phone company 42
- 5.2 Using two or more phone numbers in a single telephone line 42
- 5.3 Using three or more phone numbers in a single telephone line 42
- 5.4 Programming the ring pattern assigned for fax 43

6. Copy

Copying

- 6.1 Making a copy 44

7. Programmable Features

Features Summary

- 7.1 Programming 46
- 7.2 Basic features 46
- 7.3 Advanced features 47
- 7.4 Direct commands for programming features 49

8. Help

Error Messages

- 8.1 Error messages – Reports 51
- 8.2 Error messages – Display 51

Frequently Asked Questions

- 8.3 When a function does not work, check here 53

Replacement

- 8.4 Replacing the toner cartridge and the drum unit 56

Jams	
8.5 Recording paper jam	58
8.6 Document jams - sending.....	60
Cleaning	
8.7 Cleaning the inside of the unit	61
9. Caller IQ Feature	
Caller IQ Feature	
9.1 openLCR service for the Caller IQ feature	64
9.2 To turn the Caller IQ ON / OFF.....	64
9.3 Updating the rate table (downloading the rate table)	64
9.4 Downloading information	65
9.5 Viewing information	65
9.6 Printing information	65
10.General Information	
Printed Reports	
10.1 Reference lists and reports	66
Specifications	
10.2 Technical data about this product.....	67
FCC and Other Information	
10.3 FCC and Other Information	70
Limited Warranty	
10.4 Limited Warranty	72
Customer Services	
10.5 Customer Services directory	74
11.Index	
11.1 Index.....	75

1.1 Included accessories

No.	Item	Part number*1	Quantity	Specifications
①	Power cord	PFJA1030Z	1	-----
②	Telephone line cord	PQJA10075Z	1	-----
③	Handset	PFJXE0805Z	1	-----
④	Handset cord	PFJA1029Z	1	-----
⑤	Paper stacker	PFKS1096Z1	1	
⑥	Paper tray	PFKS1085Z1	1	-----
⑦	Drum unit	KX-FA84	1	See page 69.
⑧	Toner cartridge (complementary starter toner cartridge)	-----	1	prints about 800 letter-sized pages with a 5% image area (page 69).
⑨	A4 paper guides	PFZXFL511M	2	-----
⑩	Operating instructions	PFQX1823Z	1	-----
⑪	Quick start sheet	PFQW1969Z	1	-----

*1 Part numbers are subject to change without notice.

Note:

- If any items are missing or damaged, check with the place of purchase.
- Save the original carton and packing materials for future shipping and transportation of the unit.

①

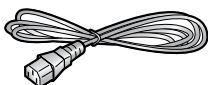

②



③



④

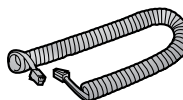

⑤

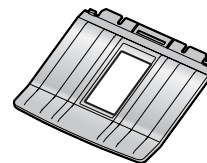

⑥

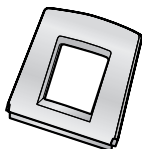

⑦

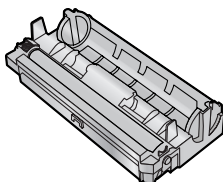

⑧

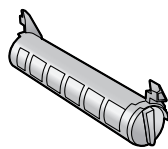

⑨

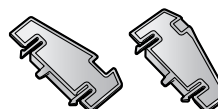

⑩



⑪

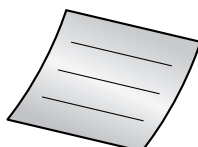

1.2 Accessory information

To ensure that the unit operates properly, we recommend the use of a Panasonic toner cartridge and drum unit.

1.2.1 Available accessories

- Replacement toner cartridge (KX-FA83)
- Replacement drum unit (KX-FA84)

- To place an order:

Telephone:

1-800-332-5368.

Fax:

1-800-237-9080.

Include:

- your name, shipping address and telephone number
- credit card type, number, expiration date and your signature
- part number and quantity

Internet:

Visit our web site:

<http://www.panasonic.com/store>
(for customers in the U.S.A. ONLY)

- If you have any questions about internet orders, please contact us at:

E-mail:

panasonicdirect@panasonic.com

Telephone:

1-866-888-2929

1.3 Description of buttons

- Keep the front cover page open for button locations.

1 [TONE]

- To change from pulse to tone temporarily during dialing when your line has rotary pulse services.

2 Station keys

- To use one-touch dial (page 31, 32, 37).

3 [BROADCAST]

- To transmit a document to multiple parties (page 38, 39).

4 [MANUAL BROAD]

- To transmit a document to multiple parties manually (page 38, 39).

5 [CALLER IQ]

- To use the Caller IQ feature (page 64).

6 [COLLATE]

- To make a collated copy (page 44).

7 [RESOLUTION]

- To select a resolution (page 36, 44).

8 [AUTO ANSWER]

- To turn ON/OFF the auto answer setting (page 39, 40).

9 [QUICK SCAN START]

- To store a scanned document into memory, and then send it (page 36).

10 [REDIAL/PAUSE]

- To redial the last number dialed.
- To insert a pause during dialing.

11 [HANDSET MUTE]

- To mute your voice to the other party during a conversation. Press this button again to resume the conversation.

12 [FLASH]

- To access special telephone services such as call waiting or for transferring extension calls.

13 [MONITOR]

- To initiate dialing.

14 [HELP]

- To print a quick reference (page 27).

15 [DIRECTORY PROGRAM]

- To store or edit names and telephone numbers (page 31).

16 [MENU]

- To initiate or exit programming.

17 [NAVIGATOR][VOLUME]

- To adjust volume (page 27).
- To search for a stored entry (page 32, 37).
- To select features or feature settings during programming (page 46).
- To navigate to the next operation.

18 [CALLER ID PRINT]

- To print the Caller ID list (page 34).

19 [CALLER ID SEARCH]

- To view caller information (page 33).

20 [LOWER][NAME/TEL NO.]

- To select stations 12–22 for one-touch dial (page 31, 32, 37).
- To change the display of the caller information (page 33).

21 [STOP]

- To stop an operation or programming.

22 [FAX START][SET]

- To initiate fax transmission or reception.
- To store a setting during programming.

23 [COPY START]

- To initiate copying (page 44).

1.4 Overview

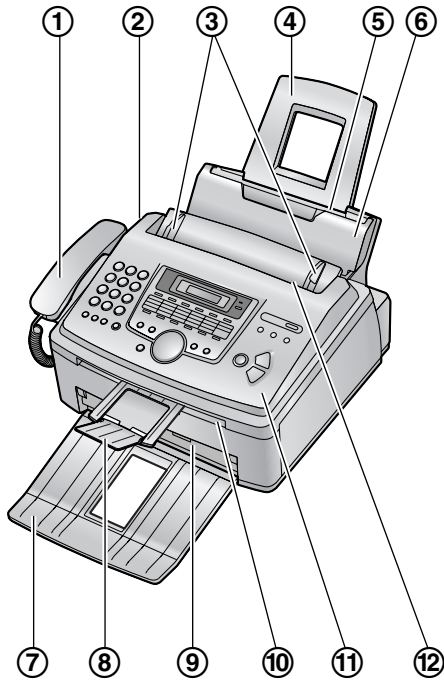

- ① Handset
- ② Speaker
- ③ Document guides
- ④ Paper tray
- ⑤ Recording paper entrance
- ⑥ Tension plate
- ⑦ Paper stacker^{*1}
- ⑧ Document stacker^{*1}
- ⑨ Recording paper exit
- ⑩ Document exit
- ⑪ Front cover
- ⑫ Document entrance

*1 The paper stacker and document stacker may not be shown in all illustrations.

1.5 Toner cartridge and drum unit

Caution:

- Read the following instructions before you begin installation. After you have read them, open the drum unit protection bag. The drum unit contains a photosensitive drum. Exposing it to light may damage the drum. Once you have opened the protection bag:
 - Do not expose the drum unit to light for more than 5 minutes.
 - Do not touch or scratch the green drum surface.
 - Do not place the drum unit near dust or dirt, or in a high humidity area.
 - Do not expose the drum unit to direct sunlight.
- Do not leave the toner cartridge out of the protection bag for a long time. It will decrease the toner life.

- 1 Before opening the protection bag of the new toner cartridge, shake it vertically more than 5 times.

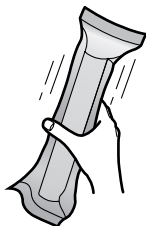

- 2 Remove the toner cartridge and drum unit from the protection bags. Peel off the seal (①) from the toner cartridge.

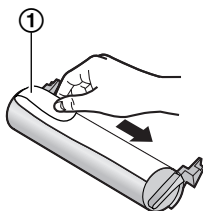

- 3 Place the toner cartridge (①) into the drum unit (②) vertically.

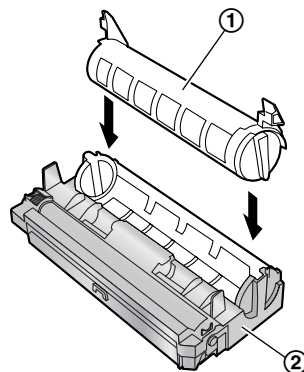

- 4 Firmly press down the toner cartridge to snap into position (①).

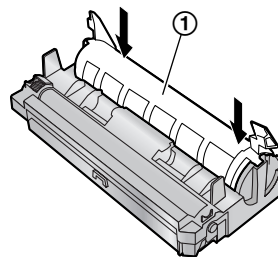

- 5 Turn the two levers (①) on the toner cartridge firmly.

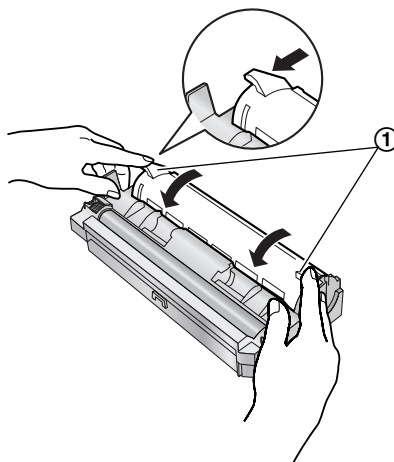

- 6 Make sure that the triangles (①) match, to install the toner cartridge correctly.

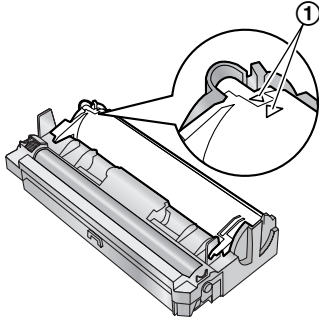

- If the lower glass (③) is dirty, clean it with a soft and dry cloth.

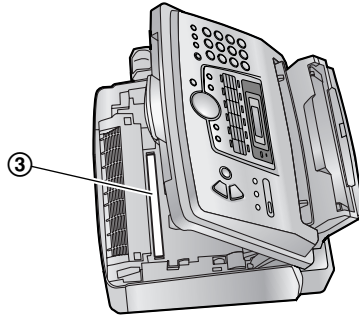

- 7 Lift open the front cover (①), holding OPEN (②).

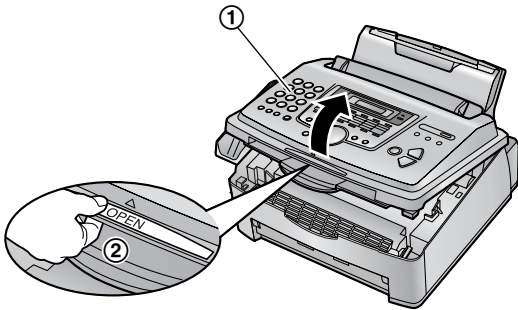

- 9 Close the front cover (①) by pushing down on both sides, until locked.

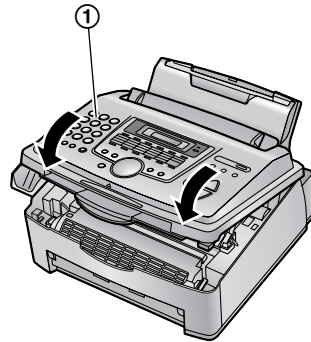

- 8 Install the drum and toner unit (①) by holding the tabs.

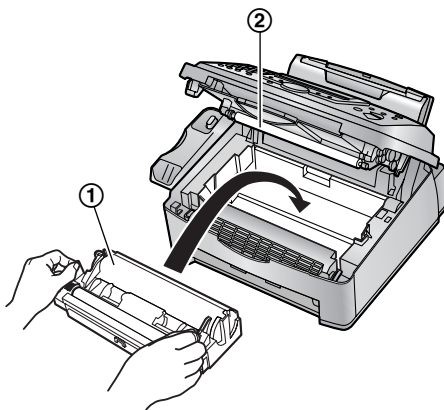

- While the unit displays “PLEASE WAIT”, do not open the front cover, or disconnect the power cord.

Toner save feature

If you want to reduce toner consumption, set the toner save setting to ON (feature #79 on page 49). The toner cartridge will last approximately 40% longer. This feature may lower the print quality.

- Do not touch the transfer roller (②).

1.6 Paper tray

Insert the paper tray (①) into the slot (②) on the back of the unit.

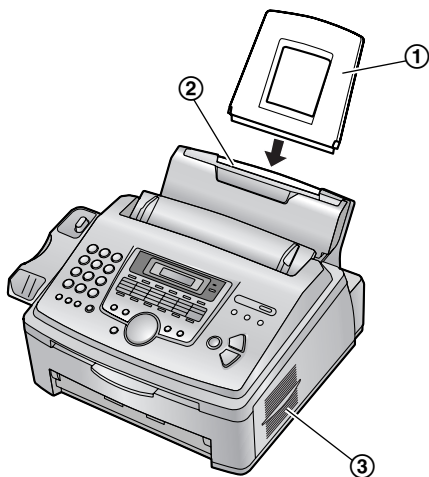

Note:

- Do not place the unit in an area where the paper tray may be obstructed (i.e., by a wall, etc.).
- Keep this surface (③) away from walls etc. more than 50 mm ($1\frac{31}{32}$ ") to let the unit cool down.

1.7 Paper stacker

Line up the slots (①) in the paper stacker with the pegs (②) on the bottom of the unit, then insert the two tabs of the paper stacker into the slots on the unit (③).

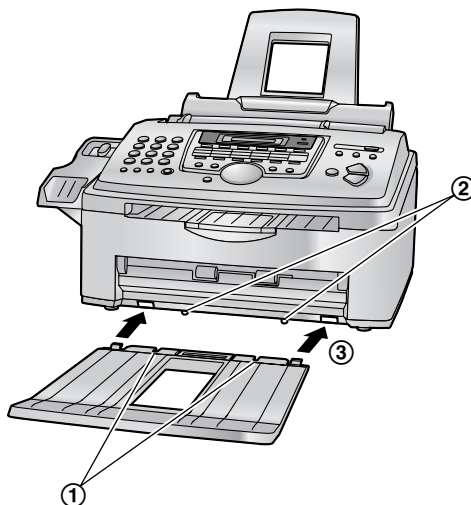

Note:

- Do not place the unit in an area where the paper stacker obstructs a walkway or is easily bumped in to.
- Document and recording paper will be ejected from the front of the unit. Do not place anything in front of the unit.
- The paper stacker can hold up to approximately 100 sheets of printed paper. Remove the printed paper before the paper stacker becomes full.

1.8 Document stacker

Pull the document stacker (①) forward gently until it clicks into place, then press the center part of the document stacker (②) to open the extender (③).

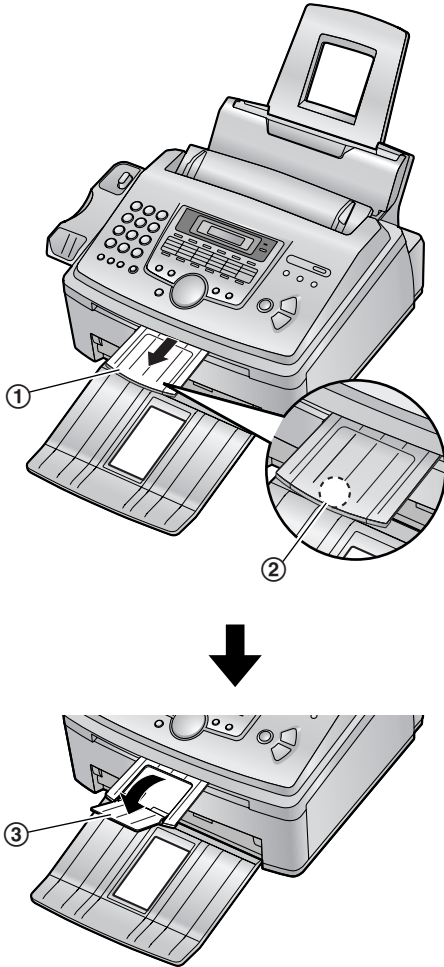

1.9 Handset cord

Connect the handset cord (①).

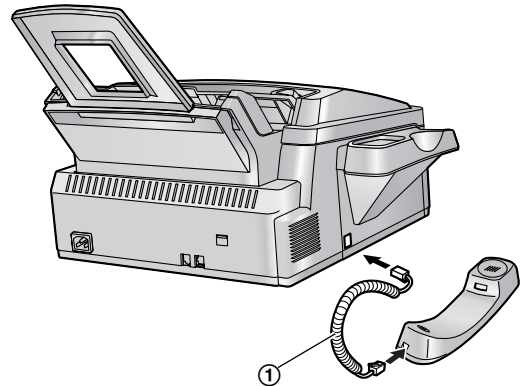

1.10 Recording paper

A4, letter or legal size recording paper can be used for fax messages. The unit can hold up to 220 sheets of 60 g/m² to 75 g/m² (16 lb. to 20 lb.) paper, 200 sheets of 80 g/m² (21 lb.) or 180 sheets of 90 g/m² (24 lb.) paper.

See the note for paper specifications (page 68).

- The unit is set for letter size paper by default. If you want to use legal or A4 size paper, change the setting (feature #16 on page 47).

- 1 Before inserting a stack of paper, fan the paper to prevent paper jams.



1. Introduction and Installation

- 2 Pull the tension plate forward (①) and insert the paper, print-side down (②), then push the tension plate (③) back.

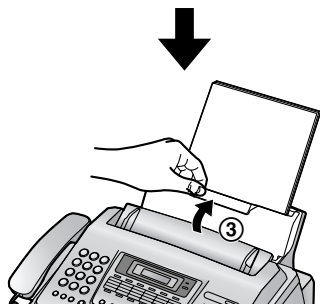
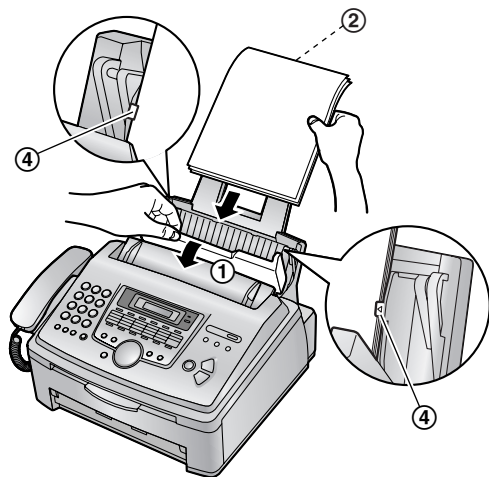

- The paper should not be over the tabs (④).
- If the paper is not inserted correctly, readjust the paper, or the paper may jam.

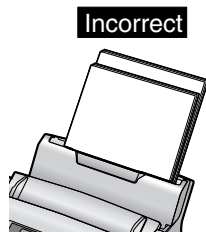
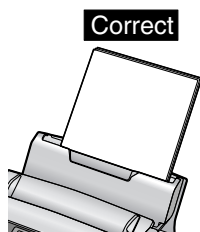

To use A4 size paper

Insert the tabs on the A4 paper guides (①) into the slots.

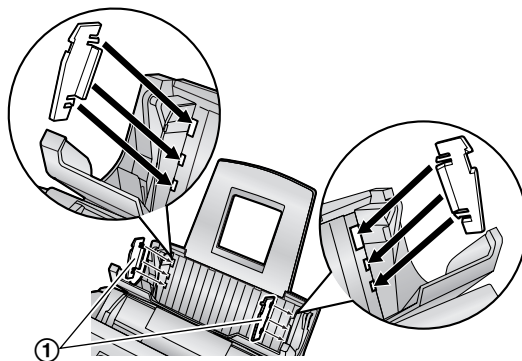

- "L" is shown on the A4 paper guide for the left side.
"R" is shown on the A4 paper guide for the right side.

2.1 Selecting the way to use your fax machine

Depending on your situation, you can select the way you prefer to use your fax machine in Quick Setup feature #00.

You can print out the Quick Setup Guide for your assistance.

- **Case 1: FAX ONLY** (page 16)
- **Case 2a: Distinctive Ring** (1 phone line with 2 or more phone numbers) (page 17)
- **Case 2b: Distinctive Ring** (using with voice mail service) (page 19)
- **Case 3: EXT. TAM** (page 21)
- **Case 4: TEL ONLY** (page 23)
- **Case 5: FAX with PC MODEM** (one phone number) (page 25)
- You cannot select case 5 in feature #00.

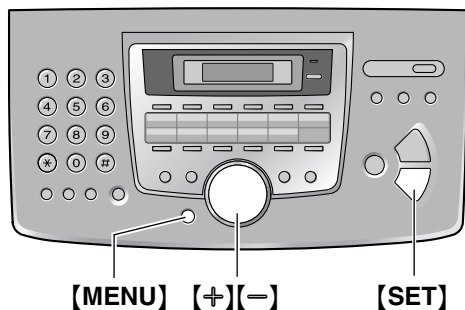

- 1 Press **[MENU]**.
 - 2 Press **[*][0][0]**.
- QUICK SETUP
PRESS SET
- 3 Press **[SET]**.
 - The Quick Setup Guide will be printed.
 - 4 Press **[+]** or **[-]** repeatedly to display the desired setting.
 - 5 Press **[SET]**.
 - 6 Press **[MENU]**.

2.1.1 Connections

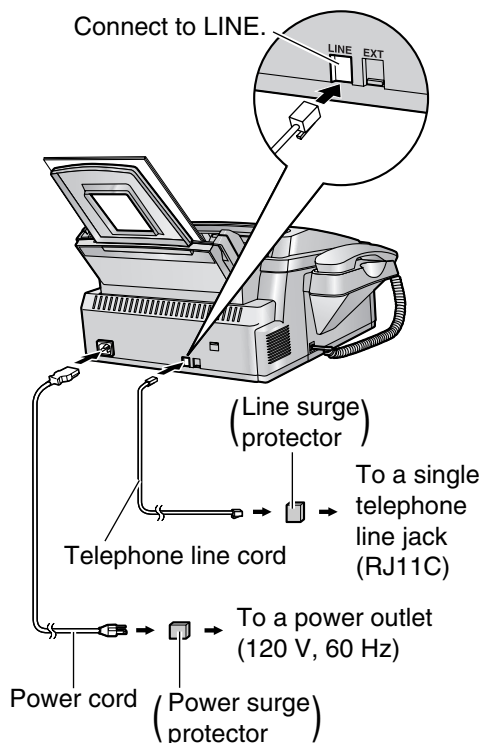

Using surge protectors

- The warranty does not cover damage due to power line surges or lightning. For additional equipment protection, we recommend the use of a surge protector.

Caution:

- **When you operate this product, the power outlet should be near the product and easily accessible.**

Note:

- To avoid malfunction, do not position fax machine near appliances such as TVs or speakers which generate an intense magnetic field.
- If any other device is connected on the same line, this unit may disturb the network condition of the device.

2.2 Case 1: FAX ONLY

2.2.1 Your situation

You wish to use the fax machine only for fax reception/transmission.

2.2.2 Telephone wiring image in house or office

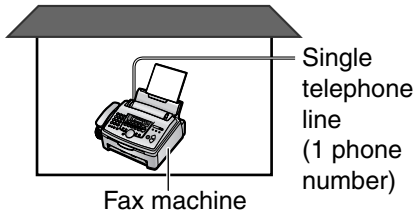

2.2.3 Connections for Case 1

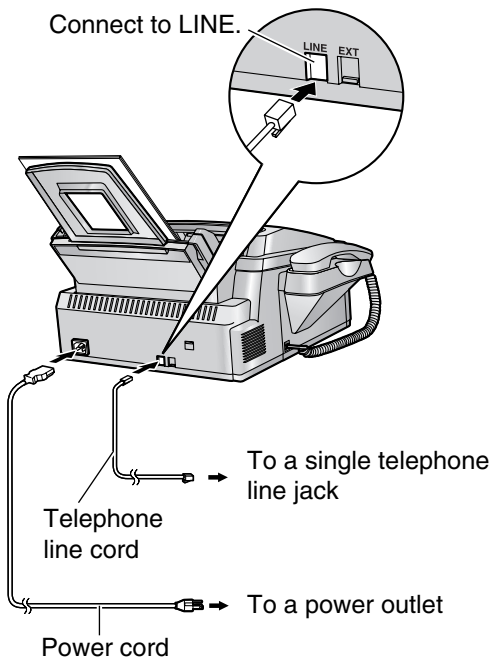

2.2.4 How to setup

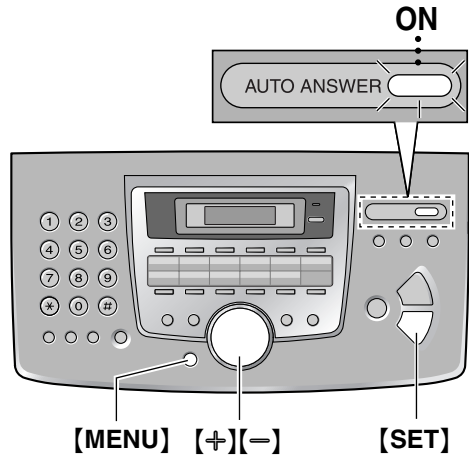

- 1 Press **[MENU]**.
- 2 Press **[*][0][0]**.

```
QUICK SETUP  
PRESS SET
```

- 3 Press **[SET]**
 - The Quick Setup Guide will be printed.
- 4 Press **[+]** or **[-]** repeatedly to display the following.

```
SELECT A SETUP  
=FAX ONLY [±]
```

- 5 Press **[SET]**.
- 6 Press **[MENU]**.
 - The AUTO ANSWER light is ON.

Note:

- The ring count is set to 2. You can change the ring setting in feature #06 (page 47).

2.2.5 How to receive calls

Just leave it. When the other party sends a fax, the fax machine will receive it automatically.

2.3 Case 2a: Distinctive Ring (1 phone line with 2 or more phone numbers)

2.3.1 Your situation

You wish to use the fax machine and your answering machine in a different room and receive faxes and phone calls automatically. You must get another phone number to use for fax besides the current phone number. To get a new phone number, you need to subscribe to Distinctive Ring service at your local telephone company.

- Distinctive Ring service may be called Identia Ring service. The name of the service depends on the telephone company.

2.3.2 Telephone wiring image in house or office

2 numbers example

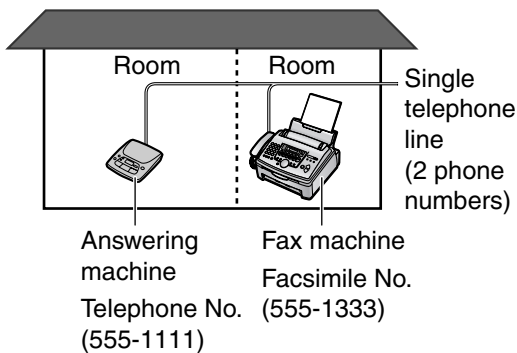

2.3.3 Connections for Case 2a

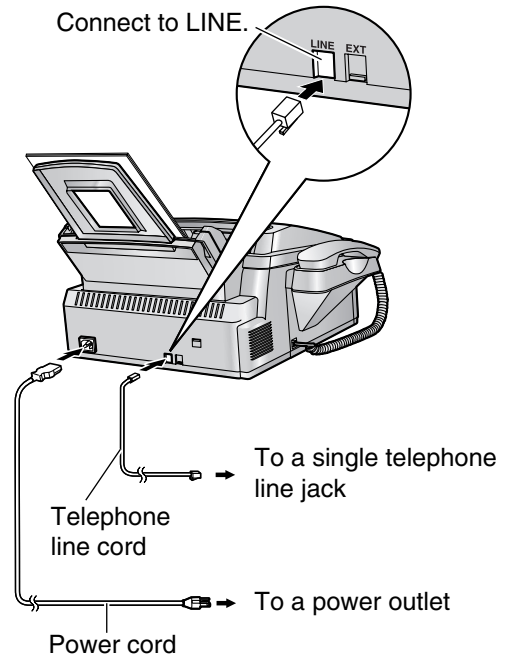

2.3.4 How to setup

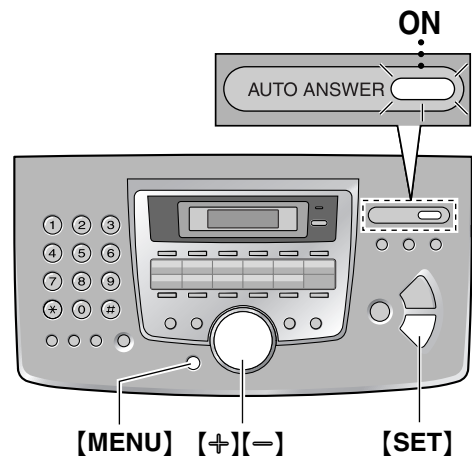

- 1 Subscribe to Distinctive Ring service at your local telephone company to get a new phone number.
- 2 Press **[MENU]**.
- 3 Press **[*][*]** then **[0][0]**.

QUICK SETUP
 PRESS SET

- 4 Press **[SET]**
 - The Quick Setup Guide will be printed.

2. Preparation

- 5 Press **[+]** or **[-]** repeatedly to display the following.

SELECT A SETUP =DIST. RING [±]

- 6 Press **[SET]**.

- 7 Press **[MENU]**.

- The AUTO ANSWER light is ON.
- You cannot change the receiving mode while the Distinctive Ring feature is activated.

2.3.5 How to receive calls

If the number assigned for phone calls is called, the fax machine and answering machine will ring and then the answering machine will record voice message automatically.

If the number assigned for fax is called, the fax machine and answering machine will ring and then the fax machine will start fax reception automatically.

If you subscribe for three or more phone numbers in a single telephone line

You will get phone numbers and each phone number has a different ring pattern.

To use one number for fax, program the ring pattern assigned for fax in feature #32 by referring to the ring pattern table (page 42).

2.4 Case 2b: Distinctive Ring (using with voice mail service)

2.4.1 Your situation

You have already subscribed to voice mail service and also wish to receive a fax automatically.

You must get another phone number to use for fax besides the current phone number. To get a new phone number, you need to subscribe to a Distinctive Ring service at your local telephone company.

- Distinctive Ring service may be called Identia Ring service. The name of the service depends on the telephone company.

2.4.2 Telephone wiring image in house or office

2 numbers example

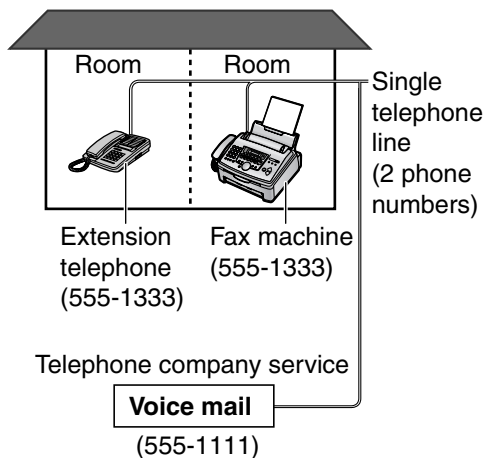

2.4.3 Connections for Case 2b

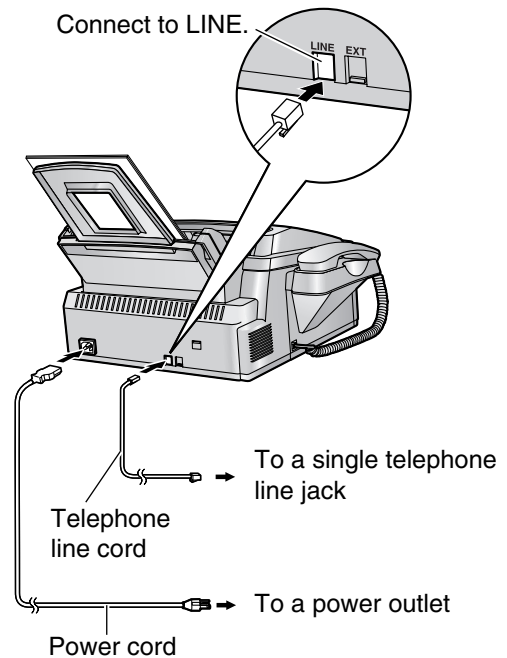

2.4.4 How to setup

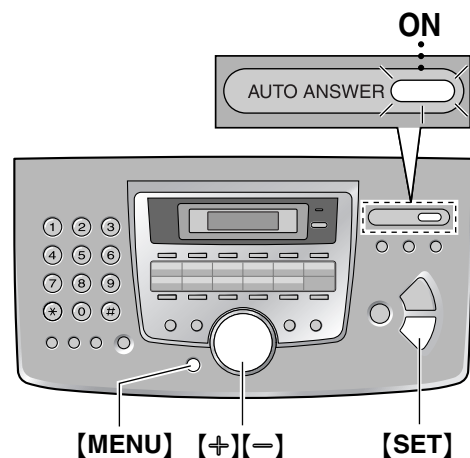

- 1 Subscribe to Distinctive Ring service at your local telephone company to get a new fax number.
 - You do not need to apply to a voice mail service for the new number.
- 2 Press **[MENU]**.
- 3 Press **[*][0]** then **[0][0]**.

QUICK SETUP
PRESS SET

- 4 Press **[SET]**
 - The Quick Setup Guide will be printed.

2. Preparation

- 5 Press **[+]** or **[-]** repeatedly to display the following.

SELECT A SETUP =DIST. RING [±]

- 6 Press **[SET]**.

- 7 Press **[MENU]**.

- The AUTO ANSWER light is ON.
- You cannot change the receiving mode while the Distinctive Ring feature is activated.

2.4.5 How to receive calls

If the number assigned for phone calls is called, the voice message will be recorded in voice mail service.

If the number assigned for fax is called, the fax machine will ring. If an extension telephone is connected on the same line, it will also ring. Then the fax machine will start fax reception automatically.

If you subscribe for three or more phone numbers in a single telephone line

You will get phone numbers and each phone number has a different ring pattern.

To use one number for fax, program the ring pattern assigned for fax in feature #32 by referring to the ring pattern table (page 42).

2.5 Case 3: EXT. TAM

2.5.1 Your situation

You wish to use the fax machine and your answering machine in the same room.

2.5.2 Telephone wiring image in house or office

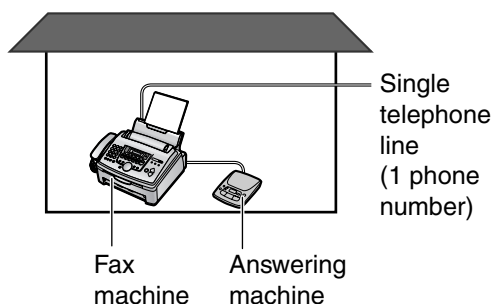

2.5.3 Connections for Case 3

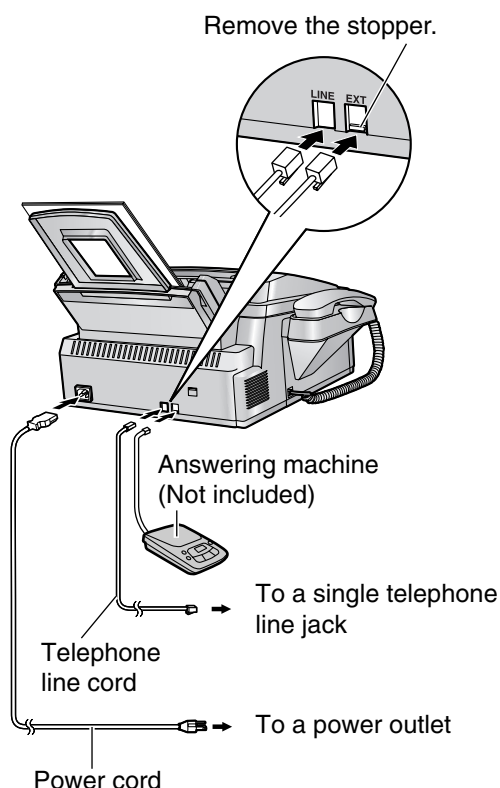

2.5.4 How to setup

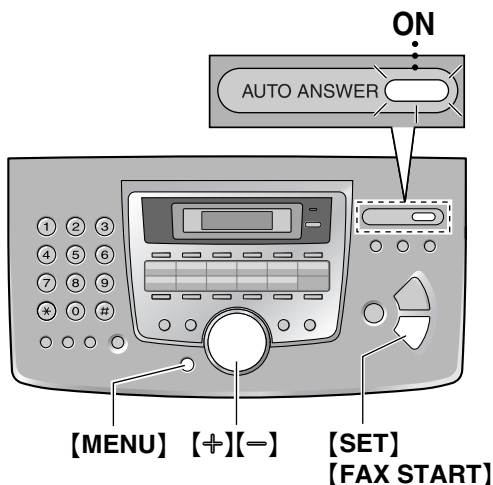

- 1 Press **[MENU]**.
 - 2 Press **[*][0][0]**.
- QUICK SETUP
PRESS SET
- 3 Press **[SET]**
 - The Quick Setup Guide will be printed.
 - 4 Press **[+]** or **[-]** repeatedly to display the following.

SELECT A SETUP
=EXT. TAM [±]
 - 5 Press **[SET]**.
 - 6 Press **[MENU]**.
 - The AUTO ANSWER light is ON.
 - 7 Turn on your answering machine.
 - 8 Adjust the ring setting of the answering machine less than 4.
 - This will allow the answering machine to answer the call first.

2.5.5 How to receive calls

At first your answering machine will pick up the call.

- If the call is a phone call, the answering machine will record voice message automatically.
- If a fax calling tone is detected, the answering machine will be disconnected and the call will be switched to the fax machine. The fax machine will receive a fax automatically.

If the answering machine is turned OFF

The fax machine will ring 5 times and receive faxes automatically.

2. Preparation

With the fax machine

1. When the fax machine rings, lift the handset of the fax machine.
2. When:
 - document reception is required,
 - a fax calling tone (slow beep) is heard, or
 - no sound is heard,press **[FAX START]**.
3. Replace the handset.
 - The fax machine will start reception.

With an extension telephone

1. When the extension telephone rings, lift the handset of the extension telephone.
2. When:
 - document reception is required,
 - a fax calling tone (slow beep) is heard, or
 - no sound is heard,press ***119** (pre-selected fax activation code) **firmly**.
3. Replace the handset.
 - The fax machine will start reception.

Note:

- You can change the fax activation code in feature #41 (page 48).

2.6 Case 4: TEL ONLY

2.6.1 Your situation

You wish to use the fax machine and an extension telephone in a different room. Most incoming calls are phone calls and the fax machine is seldom used for fax reception.

2.6.2 Telephone wiring image in house or office

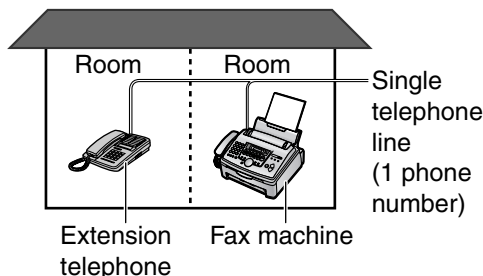

2.6.3 Connections for Case 4

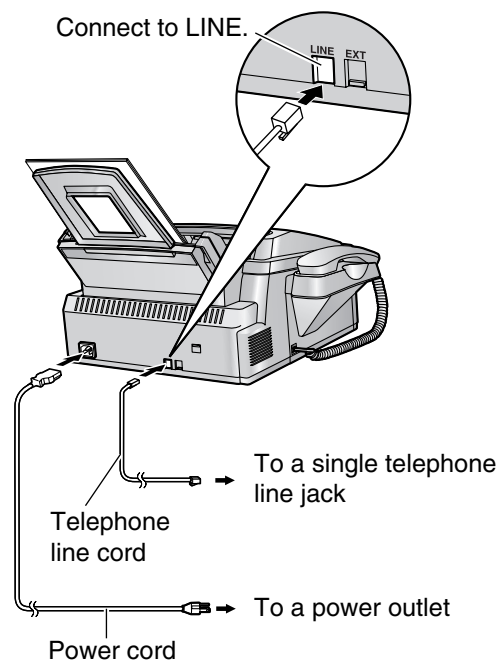

2.6.4 How to setup

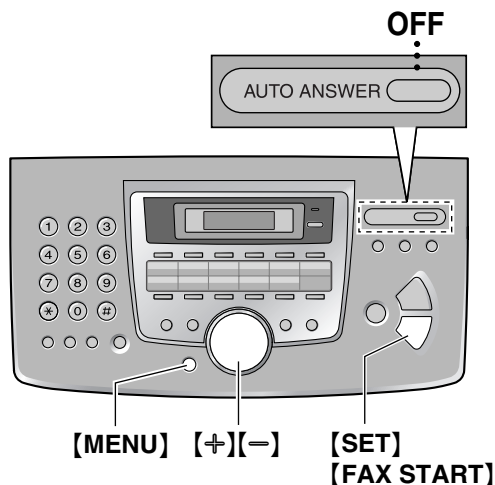

- 1 Press **[MENU]**.
- 2 Press **[*][0]** then **[0][0]**.

QUICK SETUP
 PRESS SET

- 3 Press **[SET]**
 - The Quick Setup Guide will be printed.
- 4 Press **[+]** or **[-]** repeatedly to display the following.

SELECT A SETUP
 =TEL ONLY [±]

- 5 Press **[SET]**.
- 6 Press **[MENU]**.
 - The AUTO ANSWER light is OFF.

2.6.5 How to receive calls

You can receive a fax with the fax machine and an extension telephone.

With the fax machine

1. When the fax machine rings, lift the handset of the fax machine.
2. When:
 - document reception is required,
 - a fax calling tone (slow beep) is heard, or
 - no sound is heard,
 press **[FAX START]**.
3. Replace the handset.
 - The fax machine will start reception.

With an extension telephone

1. When the extension telephone rings, lift the handset of the extension telephone.
2. When:
 - document reception is required,

2. Preparation

- a fax calling tone (slow beep) is heard, or
- no sound is heard,

press ***19** (pre-selected fax activation code) **firmly**.

3. Replace the handset.
 - The fax machine will start reception.

Note:

- You can change the fax activation code in feature #41 (page 48).

2.7 Case 5: FAX with PC MODEM (one phone number)

2.7.1 Your situation

You wish to use a computer connected via MODEM and the fax machine on a single telephone line.

The fax machine and the computer are in the same room and you do not want the computer to answer incoming calls automatically.

2.7.2 Telephone wiring image in house or office

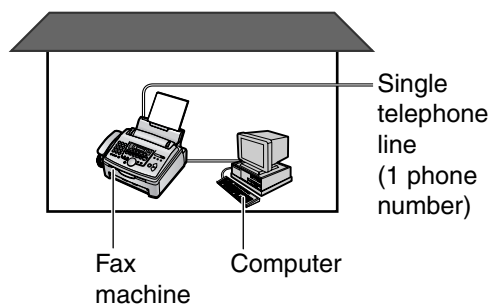

2.7.3 Connections for Case 5

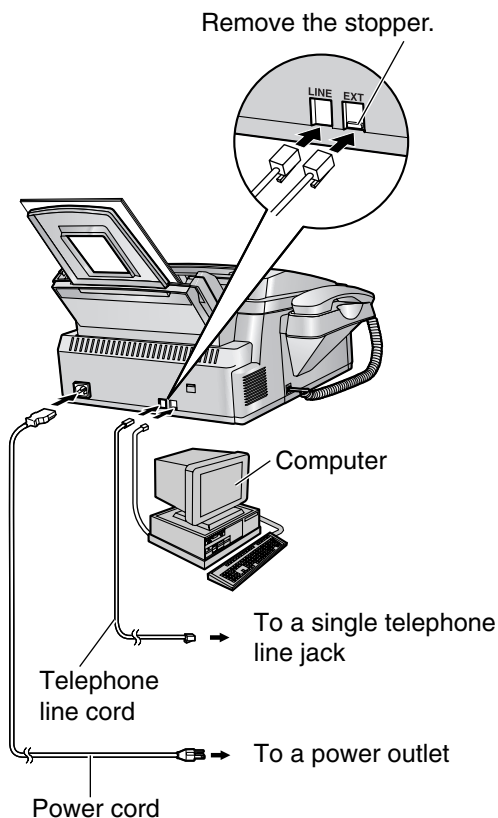

Note:

- If you are subscribed to an xDSL service, fax transmission/reception may be disturbed, or you may hear interference noise during telephone conversation. A filter to prevent this is provided from your service company. Please attach the filter to the telephone line cord of the fax machine.

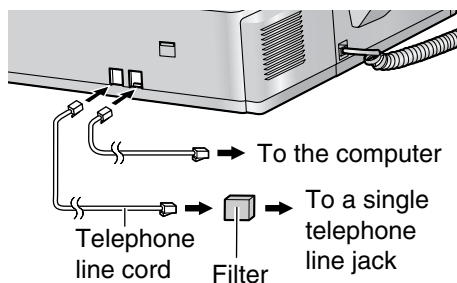

2. Preparation

2.7.4 How to setup

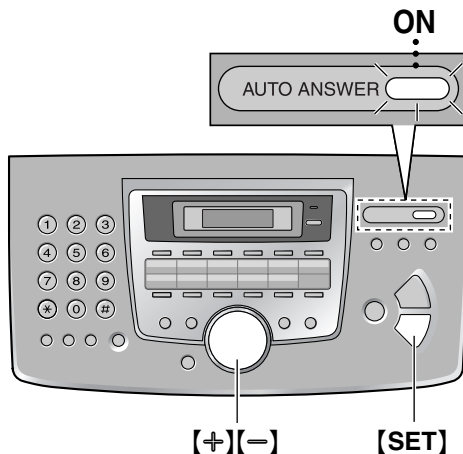

- 1 Set the fax machine to FAX ONLY mode by pressing **[AUTO ANSWER]** repeatedly to display the following.

```
FAX ONLY MODE
3 RINGS      [±]
```

- The display will show the number of rings before the fax machine answers a call in FAX ONLY mode.
 - You can change the ring count setting by pressing **[+]** or **[-]**. Press **[SET]** to complete the ring count setting.
 - The AUTO ANSWER light is ON.
- 2 Confirm the automatic answer feature on the computer is set to off.

2.7.5 How to receive calls

When receiving calls, the fax machine will automatically answer all calls and only receive fax documents.

Note:

- If you use your computer as an answering machine, please refer to page 21.
- When the fax machine is using the telephone line (e.g., during phone calls, fax sending/receiving), the telephone line is busy and MODEM cannot be used.
- When the PC is using the telephone line, the following will be displayed:

```
EXT. IN USE
```

Do not use the fax machine while the message is displayed, or else the PC activities could be disturbed.

2.8 Help function

The unit contains helpful information which can be printed for quick reference.

Basic settings:

How to set the date, time, your logo and fax number.

Feature list:

How to program the features.

Directory:

How to store names and numbers in the directory and how to dial them.

Fax sending/receiving:

Help with problems sending/receiving faxes.

Copier:

How to use the copier function.

Q and A:

Frequently asked questions and answers.

Errors:

Explanation of error messages shown on the display.

Reports:

List of available reports.

Caller ID:

How to use the Caller ID service.

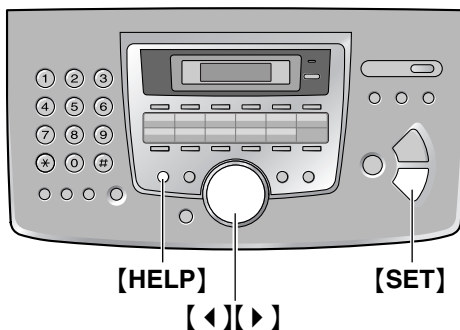

- 1 Press **[HELP]**.
- 2 Press **[◀]** or **[▶]** repeatedly to display the desired item.
- 3 Press **[SET]**.
 - The selected item will be printed.

2.9 Adjusting volume

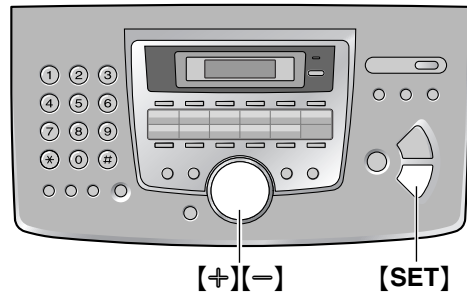

2.9.1 Ringer volume

4 levels (high/medium/low/off) are available.

While the unit is idle, press **[+]** or **[-]**.

- If any documents are in the document entrance, you cannot adjust the ringer volume. Confirm that there are no documents in the entrance.

To turn the ringer OFF:

- 1 Press **[-]** repeatedly to display the following.

RINGER OFF= OK?
 YES: SET/NO: STOP

- 2 Press **[SET]**.

RINGER OFF

- To turn the ringer back on, press **[+]**.

While the ringer volume is set to OFF:

When a call is received, the unit will not ring and will display the following.

INCOMING CALL

Ringer pattern

- You can select one of three ringer patterns for external calls (feature #17, page 47).

2.9.2 Handset receiver volume

5 levels (high to low) are available.

While using the handset, press **[+]** or **[-]**.

2.9.3 Monitor volume

8 levels (high to low) are available.

While using the monitor, press **[+]** or **[-]**.

2. Preparation

2.10 Date and time

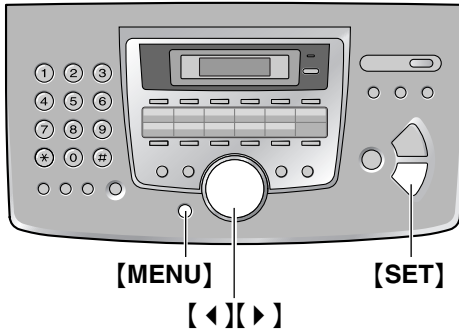

- 1 Press [MENU].

```
SYSTEM SET UP  
PRESS NAVI. [ < > ]
```

- 2 Press [<] or [>] repeatedly to display the following.

```
SET DATE & TIME  
PRESS SET
```

- 3 Press [SET].
 - Cursor (■) will appear on the display.

```
M:01/D:01/Y:03  
TIME: 12:00AM
```

- 4 Enter the current month/day/year by selecting 2 digits for each.

Example: August 10, 2003

Press [0][8][1][0][0][3].

```
M:08/D:10/Y:03  
TIME: 12:00AM
```

- 5 Enter the current hour/minute by selecting 2 digits for each. Press [*] to select "AM" or "PM".

Example: 10:15PM (12 hour clock entry)

1. Press [1][0][1][5].

```
M:08/D:10/Y:03  
TIME: 10:15AM
```

2. Press [*] repeatedly to display "PM".

```
M:08/D:10/Y:03  
TIME: 10:15PM
```

- 6 Press [SET].
 - The next feature will be displayed.

- 7 Press [MENU] to exit the program.

Note:

- This information will be printed on each page transmitted from your unit.

- The accuracy of the clock is approximately ± 60 seconds a month.

To correct a mistake

Press [<] or [>] to move the cursor to the incorrect number, and make the correction.

If you have registered with openLCR service

The date and time will be automatically set.

If you have subscribed to a Caller ID service

The date and time will be automatically set according to the received caller information.

2.11 Your logo

The logo can be your company, division or name.

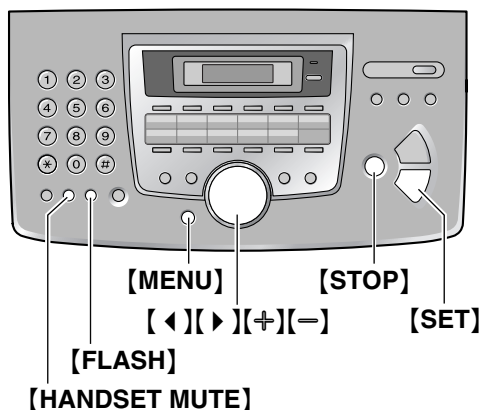

1 Press **[MENU]**.

```
SYSTEM SET UP
PRESS NAVI. [◀ ▶]
```

2 Press **[◀]** or **[▶]** repeatedly to display the following.

```
YOUR LOGO
PRESS SET
```

3 Press **[SET]**.

- Cursor (█) will appear on the display.

```
LOGO=█
```

4 Enter your logo, up to 30 characters. See the character table on page 29 for details.

5 Press **[SET]**.

- The next feature will be displayed.

6 Press **[MENU]** to exit the program.

Note:

- This information will be printed on each page transmitted from your unit.

To select characters with the dial keypad

Keys	Characters
[1]	1 [] { } + - / = , . _ ` : ; ?
[2]	A B C a b c 2
[3]	D E F d e f 3
[4]	G H I g h i 4

Keys	Characters
[5]	J K L j k l 5
[6]	M N O m n o 6
[7]	P Q R S p q r s 7
[8]	T U V t u v 8
[9]	W X Y Z w x y z 9
[0]	0 () < > ! " # \$ % & ¥ * @ ^ ' →
[#]	To change capital or lower-case letter.
[FLASH]	Hyphen button
[HANDSET MUTE]	Insert button
[STOP]	Delete button

Note:

- To enter another character located on the same number key, press **[▶]** to move the cursor to the next space.

To enter your logo

Example: "BILL"

1. Press **[2]** 2 times.

```
LOGO=B
```

2. Press **[4]** 3 times.

```
LOGO=BI
```

3. Press **[5]** 3 times.

```
LOGO=BIL
```

4. Press **[▶]** to move the cursor to the next space and press **[5]** 3 times.

```
LOGO=BILL
```

To change capital or lower-case letters

Pressing the **[#]** key will change to capital or lower-case alternately.

1. Press **[2]** 2 times.

```
LOGO=B
```

2. Press **[4]** 3 times.

```
LOGO=BI
```

2. Preparation

3. Press **[#]**.

LOGO=Bi

4. Press **[5]** 3 times.

LOGO=Bi1

To correct a mistake

Press **[◀]** or **[▶]** to move the cursor to the incorrect character, and make the correction.

To delete a character

Press **[◀]** or **[▶]** to move the cursor to the character you want to delete and press **[STOP]**.

To insert a character

1. Press **[◀]** or **[▶]** to move the cursor to the position to the right of where you want to insert the character.
2. Press **[HANDSET MUTE]** to insert a space and enter the character.

To select characters using **[+]** or **[-]**

Instead of pressing the dial keys, you can select characters using **[+]** or **[-]**.

1. Press **[+]** or **[-]** repeatedly to display the desired character.
2. Press **[▶]** to move the cursor to the next space.
 - The character displayed is inserted.
3. Return to step 1 to enter the next character.

Display order of characters

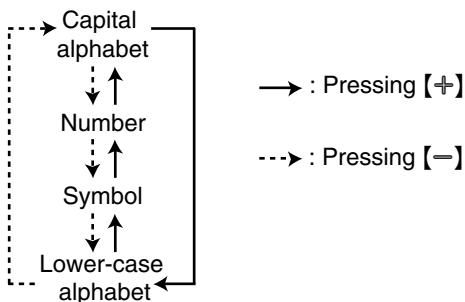

2.12 Your fax number

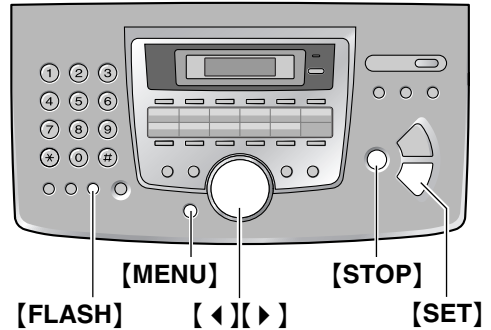

1 Press **[MENU]**.

SYSTEM SET UP
PRESS NAVI. [◀ ▶]

2 Press **[◀]** or **[▶]** repeatedly to display the following.

YOUR FAX NO.
PRESS SET

3 Press **[SET]**.

- Cursor (█) will appear on the display.

NO. = █

4 Enter your fax number, up to 20 digits.

Example:

NO. = 1234567 █

5 Press **[SET]**.

- The next feature will be displayed.

6 Press **[MENU]** to exit the program.

Note:

- This information will be printed on each page transmitted from your unit.
- The **[*]** button enters a “+” and the **[#]** button enters a space.

Example: +234 5678

Press **[*][2][3][4][#][5][6][7][8]**.

- To enter a hyphen in a telephone number, press **[FLASH]**.

To correct a mistake

Press **[◀]** or **[▶]** to move the cursor to the incorrect number, and make the correction.

To delete a number

Press **[◀]** or **[▶]** to move the cursor to the number you want to delete and press **[STOP]**.

3.1 Storing names and telephone numbers into one-touch dial

Up to 22 telephone numbers can be stored in one-touch dial for quick access.

- Station 1 to 3 can be used alternatively as broadcast keys (page 38).
- You can also send faxes using one-touch dial (page 37).

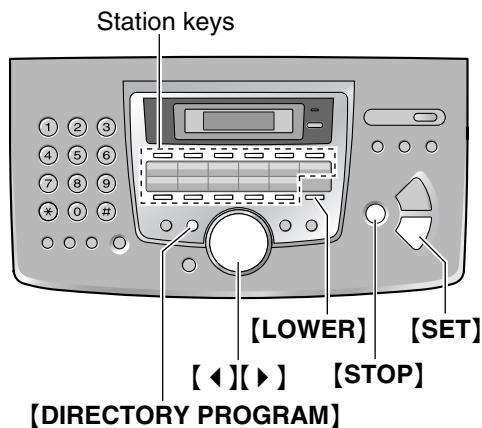

- 1 Press **[DIRECTORY PROGRAM]**.
- 2 Select the desired station key.

For stations 1–3:

 1. Press one of the station keys.
 2. Press **[SET]**.

For stations 4–11:

Press one of the station keys.

For stations 12–22:

Press **[LOWER]**, then press one of the station keys.
- 3 Enter the name, up to 10 characters (page 29 for instructions).
- 4 Press **[SET]**.
- 5 Enter the telephone number, up to 30 digits.
- 6 Press **[SET]**.
 - To program other entries, repeat steps 2 to 6.
- 7 Press **[DIRECTORY PROGRAM]**.

Helpful hints:

- You can confirm the stored entries in the telephone number list (page 66).

Note:

- A hyphen or a space entered in a telephone number counts as two digits.

To correct a mistake

Press **[< >]** or **[> >]** to move the cursor to the incorrect character/number, and then make the correction.

To delete a character/number

Press **[< >]** or **[> >]** to move the cursor to the character/number you want to delete, and press **[STOP]**.

3.2 Storing names and telephone numbers into the navigator directory

Up to 100 telephone numbers can be stored in the navigator directory for quick access.

- You can also send faxes using the navigator directory (page 37).

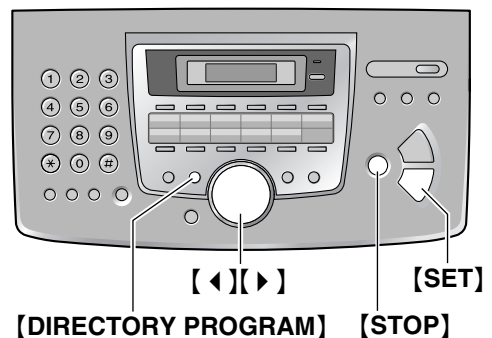

- 1 Press **[DIRECTORY PROGRAM]**.
- 2 Press **[> >]**.
- 3 Enter the name, up to 10 characters (see page 29 for instructions).
- 4 Press **[SET]**.
- 5 Enter the telephone number, up to 30 digits.
- 6 Press **[SET]**.
 - To program other entries, repeat steps 3 to 6.
- 7 Press **[DIRECTORY PROGRAM]**.

Helpful hints:

- For your convenience, HELP-FAX (1-800-435-7329) has been pre-programmed. If you cannot solve a problem, call using this entry

3. Telephone

(page 32). If unnecessary, you can erase it (page 32).

- You can confirm the stored entries in the telephone number list (page 66).

Note:

- If "SPACE= 5 DIRS." is displayed, you can store only 5 more entries.
- A hyphen or a space entered in a telephone number counts as 2 digits.

To correct a mistake

Press [◀] or [▶] to move the cursor to the incorrect character/number, and then make the correction.

To delete a character/number

Press [◀] or [▶] to move the cursor to the character/number you want to delete, and press [STOP].

3.3 Editing a stored entry

- Keep the front cover page open for button locations.

- 1 Press [▶].
 - Confirm that there are no documents in the document entrance.
- 2 Press [⊕] or [⊖] repeatedly to display the desired entry.
- 3 Press [DIRECTORY PROGRAM].
- 4 Press [✖].
 - If you do not need to edit the name, skip to step 6.
- 5 Edit the name (see the storing procedure on page 31 for instructions).
- 6 Press [SET].
 - If you do not need to edit the telephone number, skip to step 8.
- 7 Edit the telephone number. For further details, see the storing procedure on page 31.
- 8 Press [SET].

3.4 Erasing a stored entry

- Keep the front cover page open for button locations.

- 1 Press [▶].

- Confirm that there are no documents in the document entrance.

- 2 Press [⊕] or [⊖] repeatedly to display the desired entry.
- 3 Press [DIRECTORY PROGRAM].
- 4 Press [⊞].
 - To cancel erasing, press [STOP].
- 5 Press [SET].

3.5 Making a phone call using one-touch dial and navigator directory

Before using this feature, program the desired names and telephone numbers into one-touch dial and navigator directory (page 31).

- Keep the front cover page open for button locations.

3.5.1 Using one-touch dial

- 1 Press [MONITOR] or lift the handset.
- 2 Select the desired station key.

For stations 1–11:

Press the desired station key.

For stations 12–22:

Press [LOWER], then press the desired station key.

- The unit will start dialing automatically.

3.5.2 Using the navigator directory

- 1 Press [▶].
 - Confirm that there are no documents in the document entrance.
- 2 Press [⊕] or [⊖] repeatedly to display the desired entry.
- 3 Press [MONITOR] or lift the handset.
 - The unit will start dialing automatically.

To search for a name by initial

Example: "LISA"

1. Press [▶].
 - Confirm that there are no documents in the document entrance.
2. Press [⊕] or [⊖] to initiate the navigator directory.

3. Press **[5]** repeatedly to display any name with the initial "L" (see the character table, page 29).
 - To search for symbols (not letters or numbers), press **[*]**.
4. Press **[+]** or **[-]** repeatedly to display "LISA".
 - To stop the search, press **[STOP]**.
 - To dial the displayed number, press **[MONITOR]** or lift the handset.

3.6 Caller ID service

This unit is compatible with the Caller ID service offered by your local telephone company. To use this feature, you must subscribe to a Caller ID service. Change the following ring setting to 2 or more rings beforehand.

- FAX ring setting (feature #06, page 47)

3.6.1 How Caller ID is displayed

The calling party's name or telephone number will be displayed after the first ring. You then have the option of whether or not to answer the call depending on the caller.

The unit will automatically store the caller information (name, telephone number and the time of the call). You can view the caller information (page 33) and print the Caller ID list (page 34).

- If the unit is connected to a PBX (Private Branch Exchange) system, you may not receive the caller information. Consult your PBX supplier.
- If the unit cannot receive caller information, the following will be displayed:
 "OUT OF AREA": The caller dialed from an area which does not provide Caller ID service.
 "PRIVATE CALLER": The caller requested not to send caller information.
 "LONG DISTANCE": The caller made a long distance call.

To confirm caller information using the Caller ID list

The unit will store information for the most recent 30 callers.

- To print manually, see page 34.
- To print automatically after every 30 new calls, activate feature #26 (page 48).

3.7 Viewing and calling back using caller information

You can easily view caller information and call back.

Important:

- Calling back will not be possible in the following cases:
 - The telephone number includes data other than numbers (i.e., * or #).
 - The caller information does not include a telephone number.

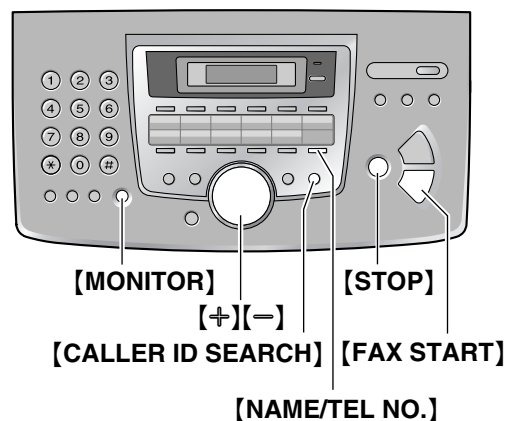

- 1 Press **[CALLER ID SEARCH]**.
- 2 Press **[+]** to search from the most recent calls.
Press **[-]** to search from the oldest calls.
- 3 Press **[MONITOR]** or lift the handset to call back the displayed party.
 - The unit will start dialing automatically.
 - To send a fax, insert the document FACE DOWN and press **[FAX START]**.

To change the display of the caller information

Press **[NAME/TEL NO.]** repeatedly after step 2.

Example:

SAM LEE 11:20AM Jul 20 ✓
↑
1345678901 11:20AM Jul 20 ✓

- Check mark (✓) on the display means the call has already been viewed or answered.

3. Telephone

Display while viewing

- When the unit did not receive name information, the display will show "NO NAME RCVD".
- When no calls have been received, the display will show "NO CALLER DATA".

To edit a telephone number for calling back

Press [*****] repeatedly after step 2. Each time you press [*****], the telephone number will be changed as follows:

- 1 - Area code - Local telephone number ("1" added)
2. Local telephone number (area code omitted)
3. Area code - Local telephone number
4. 1 - Local telephone number ("1" added and area code omitted)

To stop viewing

Press [**STOP**] after step 2.

3.8 Printing the Caller ID list

- Keep the front cover page open for button locations.
- 1 Press [**CALLER ID PRINT**] to start printing.
 - The display will show "ALL ERASE OK?" after printing.
 - 2 Press [**STOP**] to exit the program.
 - To erase all of the stored caller information, press [**SET**] instead of [**STOP**].

3.9 Erasing caller information

- Keep the front cover page open for button locations.

3.9.1 Erasing all caller information

- 1 Press [**MENU**] repeatedly to display "CALLER SET UP".
- 2 Press [**SET**].
- 3 Press [**SET**].
 - To cancel erasing, press [**STOP**], then [**MENU**].
- 4 Press [**SET**].

- 5 Press [**STOP**] to exit the program.

3.9.2 Erasing specific caller information

- 1 Press [**CALLER ID SEARCH**].
- 2 Press [**+**] or [**-**] repeatedly to display the desired entry.
- 3 Press [**◀**].
 - To cancel erasing, press [**STOP**] 2 times.
- 4 Press [**SET**].
 - To erase other entries, repeat steps 2 to 4.
- 5 Press [**STOP**] to exit the program.

3.10 Storing caller information

Important:

- This feature is not available in the following cases.
 - The telephone number includes data other than numbers (i.e., * or #).
 - The caller information does not include a telephone number.

- Keep the front cover page open for button locations.
- 1 Press [**CALLER ID SEARCH**].
 - 2 Press [**+**] or [**-**] repeatedly to display the desired entry.
 - 3 Press [**DIRECTORY PROGRAM**].
 - 4 Select the station key or navigator directory.

For stations 1–3:

1. Press the desired station key.
2. Press [**SET**].
3. Press [**SET**].

For stations 4–11:

1. Press the desired station key.
2. Press [**SET**].

For stations 12–22:

1. Press [**LOWER**], then press the desired station key.
2. Press [**SET**].

For navigator directory:

1. Press [**◀**] or [**▶**].
2. Press [**SET**].

5 Press [SET].

Note:

- You can confirm the stored entries in the telephone number list (page 66).
- The unit can only store a name of up to 10 characters long.
- To edit a name or number, see page 32.
- If you enter a new entry into a station key, the previous entry will be replaced.
- If you use stations 1–3 as broadcast keys, you cannot store caller information for stations 1–3 (page 38).

4.1 Sending a fax manually

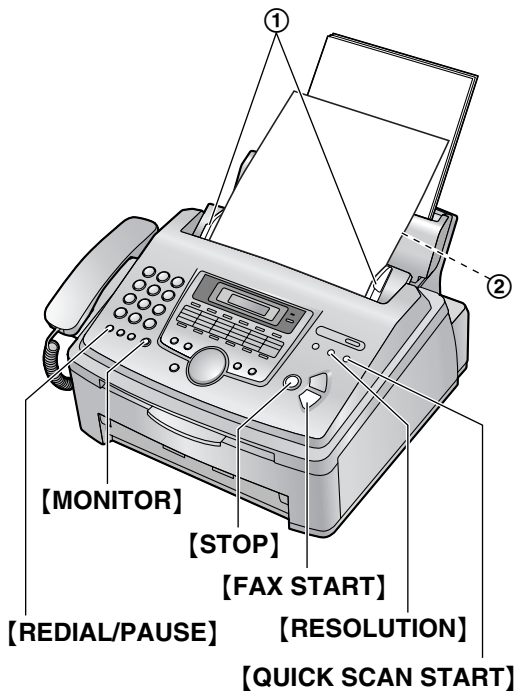

- 1 Adjust the width of the document guides (①) to the size of the document.
- 2 Insert the document (up to 20 pages) FACE DOWN (②) until a single beep is heard and the unit grasps the document.
- 3 If necessary, press **[RESOLUTION]** repeatedly to select the desired resolution.
- 4 Press **[MONITOR]**.
- 5 Dial the fax number.
- 6 **When a fax tone is heard:**
Press **[FAX START]**.

When the other party answers your call:

Lift the handset and ask them to press their start button. When the fax tone is heard, press **[FAX START]**.

To select the resolution

Select the desired resolution according to the type of document.

- “STANDARD”: For printed or typewritten originals with normal-sized characters.
- “FINE”: For originals with small printing.

- “SUPER FINE”: For originals with very small printing. This setting only works with other compatible fax machines.
- “PHOTO”: For originals containing photographs, shaded drawings, etc.
- “PHOTO WITH TEXT”: For originals containing photographs and text.
- Using the “FINE”, “SUPER FINE”, “PHOTO” and “PHOTO WITH TEXT” settings will increase transmission time.
- If the resolution setting is changed during feeding, it will be effective from the next sheet.

To redial the last number

1. Press **[REDIAL/PAUSE]**.
2. Press **[FAX START]**.
- If the line is busy, the unit will automatically redial the number up to 2 times.
- To cancel redialing, press **[STOP]**.

To send more than 20 pages at a time

Insert the first 20 pages of the document. Add the other pages (up to 20 at a time) before the last page feeds into the unit.

Pre-dialing a fax number

You can dial the fax number first before inserting the document. This is convenient if you need to refer to the document for the other party's fax number.

1. Enter the fax number.
2. Insert the document.
3. Press **[FAX START]**.

Sending from memory (Quick scan feature)

You can scan the document into memory before sending.

1. Insert the document.
2. Enter the fax number.
3. Press **[QUICK SCAN START]**.
- The document will be fed into the unit and scanned into memory. The unit will then transmit the data. If the document exceeds the memory capacity, sending will be canceled and this feature will be turned OFF automatically. You must transmit the entire document manually.

To stop transmission

Press **[STOP]**.

Sending report for confirmation

A sending report provides you with a printed record of transmission results. To use this feature, activate feature #04 (page 46). For an explanation of error messages in the result column, see page 51.

Journal report

A journal report provides you with a printed record of the 30 most recent faxes. To print manually, see page 66. To print automatically after every 30 new fax communications, activate feature #22 (page 47). For an explanation of error messages in the result column, see page 51.

4.2 Documents you can send

Minimum document size

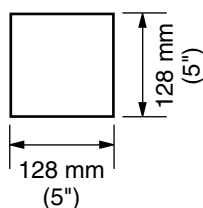

Maximum document size

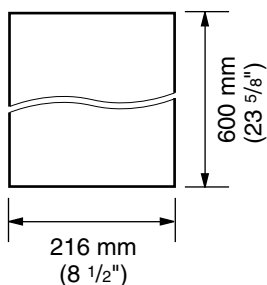

Effective scanning area

- Shaded area (1) will be scanned.

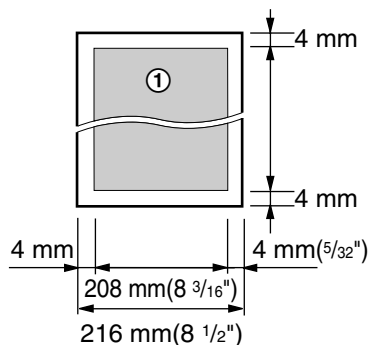

Document weight

- Single sheet:
45 g/m² to 90 g/m² (12 lb. to 24 lb.)
- Multiple sheets:
60 g/m² to 80 g/m² (16 lb. to 21 lb.)

Note:

- Remove clips, staples or other fasteners.
- Do not send the following types of documents: (Use copies for fax transmission.)
 - Chemically treated paper such as carbon or carbonless duplicating paper
 - Electrostatically charged paper
 - Badly curled, creased or torn paper
 - Paper with a coated surface
 - Paper with a faint image
 - Paper with printing on the opposite side that can be seen through the other side, such as newsprint
- Check that ink, paste or correction fluid has dried completely.
- To transmit a document with a width of less than 210 mm (8¹/₄"), we recommend using a copy machine to copy the original document onto letter-sized paper, then transmitting the copied document.

4.3 Sending a fax using one touch dial and navigator directory

Before using this feature, program the desired names and telephone numbers into one touch dial and navigator directory (page 31).

- Keep the front cover page open for button locations.

- Adjust the width of the document guides to the size of the document.
- Insert the document (up to 20 pages) FACE DOWN until a single beep is heard and the unit grasps the document.
- If necessary, press **[RESOLUTION]** repeatedly to select the desired resolution (page 36).

4. Fax

4 Enter the fax number.

Using stations 1–11:

Press the desired station key.

Using stations 12–22:

Press [**LOWER**], then press the desired station key.

Using navigator directory:

Press [**◀**] or [**▶**], then press [**+**] or [**–**] repeatedly to display the desired entry and press [**SET**].

Fax auto redial

If the line is busy or if there is no answer, the unit will automatically redial the number up to 2 times.

- To cancel redialing, press [**STOP**].

If your unit does not send a fax

- Confirm the stored telephone number on the display and check that the number dialed is answered by the other party's machine.
- The connecting tone will be heard during dialing to tell you the status of the other party's machine (feature #76, page 48).

4.4 Broadcast transmission

By programming entries from one-touch dial (page 31) and navigator directory (page 31) into the broadcast memory, you can send the same document to multiple parties (up to 20). Your programmed entries will remain in the broadcast memory, allowing frequent re-use. See page 39 for broadcast transmission instructions.

- The broadcast function utilizes stations 1–3. The one-touch dial function will be disabled.
- Keep the front cover page open for button locations.

4.4.1 Programming entries into the broadcast memory

1 Press [**DIRECTORY PROGRAM**].

2 Select the desired broadcast key.

For BROADCAST 1-2:

1. Press the desired [**BROADCAST**] key.
2. Press [**+**] or [**–**] repeatedly to select "BROADCAST".

For MANUAL BROADCAST:

1. Press [**MANUAL BROAD**].

2. Press [**+**] or [**–**] repeatedly to select "MANUAL BROAD".

3 Press [**SET**].

4 Program entries.

Using stations 1–11:

Press the desired station key.

Using stations 12–22:

Press [**LOWER**], then press the desired station key.

Using navigator directory:

Press [**+**] or [**–**] repeatedly to display the desired entry, and press [**SET**].

Using the dial keypad (only for MANUAL BROADCAST):

Enter the fax number and press [**SET**].

- To program other entries, repeat this step (up to 20 entries).

5 Press [**SET**] after programming all of the desired entries.

- To program another broadcast key, repeat steps 2 to 5.

6 Press [**STOP**] to exit the program.

Note:

- If you program the wrong entry, press [**STOP**] after step 4 to erase the entry.
- Confirm the stored entries by printing a broadcast programming list (page 66).

4.4.2 Adding a new entry into the broadcast memory

After initial programming, you can add new entries (up to a combined total of 20).

1 Press [**▶**].

- Confirm that there are no documents in the document entrance.

2 Press [**+**] or [**–**] repeatedly to display the desired broadcast memory ("**<BROADCAST1>**", "**<BROADCAST2>**" or "**<MANUAL BROAD>**").

3 Press [**DIRECTORY PROGRAM**].

4 Press [**✕**].

5 Press [**+**] or [**–**] repeatedly to display the desired entry.

6 Press [**SET**].

- To add other entries, repeat steps 5 and 6 (up to 20 entries).

- 7 Press **[DIRECTORY PROGRAM]** to exit the program.

4.4.3 Erasing a stored entry from the broadcast memory

- 1 Press **[▶]**.
 - Confirm that there are no documents in the document entrance.
- 2 Press **[+]** or **[-]** repeatedly to display the desired broadcast memory ("**<BROADCAST1>**", "**<BROADCAST2>**" or "**<MANUAL BROAD>**").
- 3 Press **[DIRECTORY PROGRAM]**.
- 4 Press **[#]**.
- 5 Press **[+]** or **[-]** repeatedly to display the desired entry you want to erase.
 - To cancel erasing, press **[STOP]**.
- 6 Press **[SET]**.
- 7 Press **[SET]**.
 - To erase other entries, repeat steps 5 to 7.
- 8 Press **[DIRECTORY PROGRAM]** to exit the program.

4.4.4 Sending the same document to pre-programmed parties

- 1 Insert the document FACE DOWN.
- 2 If necessary, press **[RESOLUTION]** repeatedly to select the desired resolution (page 36).
- 3 Press the desired **[BROADCAST]** (1-2) or **[MANUAL BROAD]**.
 - The document will be fed into the unit and scanned into memory. The unit will then transmit the data to each entry, calling each number sequentially.
 - After transmission, the stored document will be erased automatically, and the unit will automatically print a broadcast sending report.

Note:

- If you select "FINE", "SUPER FINE", "PHOTO" or "PHOTO WITH TEXT" resolution, the number of pages that the unit can transmit will decrease.
- If the document exceeds the memory capacity, sending will be canceled.

- If one of the entries is busy or does not answer, it will be skipped and redialed later up to 2 times.

To cancel broadcast transmission

1. Press **[STOP]** while the unit displays "BROADCASTING".
 - The display will show "SEND CANCELED?".
2. Press **[SET]**.

4.5 Receiving a fax manually

4.5.1 Activating TEL mode

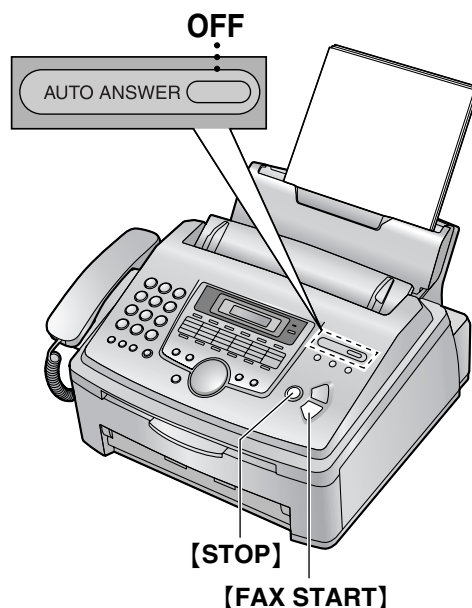

Set the fax machine to TEL mode by pressing **[AUTO ANSWER]** repeatedly to display the following.

TEL MODE

- The AUTO ANSWER light is OFF.

How to receive calls

1. When the unit rings, lift the handset to answer the call.
2. When:
 - document reception is required,
 - a fax calling tone (slow beep) is heard, or
 - no sound is heard,

4. Fax

press **[FAX START]**.

CONNECTING.....

3. Replace the handset.
 - The unit will start fax reception.
 - If you do not answer the call within 10 rings, the unit will temporarily switch to fax reception. The other party can then send a fax.

To stop receiving

Press **[STOP]**.

Extension telephone

You can receive fax documents using an extension telephone.

Important:

- Use a touch tone telephone as the extension telephone.
1. When the extension telephone rings, lift the handset of the extension telephone.
 2. When:
 - document reception is required,
 - a fax calling tone (slow beep) is heard, or
 - no sound is heard,press ***119** (pre-selected fax activation code) **firmly**.
 3. Replace the handset.
 - The fax machine will start reception.

Note:

- To receive fax documents using the extension telephone, you must set the remote fax activation to ON (feature #41, page 48) beforehand.

4.6 Receiving a fax automatically

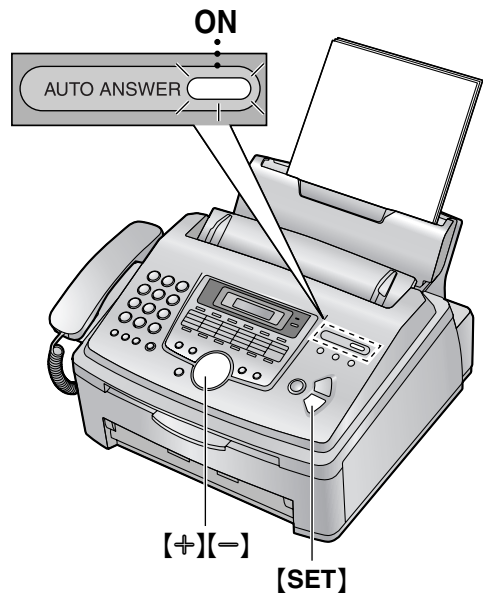

4.6.1 Activating FAX ONLY mode

- 1 Press **[AUTO ANSWER]** repeatedly to display the following.

FAX ONLY MODE
3 RINGS [±]

- The display will show the number of rings before the unit answers a call in FAX ONLY mode.
 - The AUTO ANSWER light is ON.
- 2 If you wish to change the ring setting, press **[+]** or **[-]** repeatedly to display the desired number, and press **[SET]**.

How to receive calls

When receiving calls, the unit will automatically answer all calls and only receive fax documents.

4.7 Junk fax prohibitor (preventing fax reception from undesired callers)

If you subscribe to Caller ID service, this feature prevents fax reception from calls that do not show caller information.

Additionally, faxes originating from numbers that match a programmable junk fax prohibitor list will not be accepted by the fax machine (page 41).

- Keep the front cover page open for button locations.

Important:

- **This feature does not work when:**
 - the unit is set to the TEL mode, or
 - manual reception is performed.

4.7.1 Activating the junk fax prohibitor

- 1 Press **[MENU]** repeatedly to display “JUNK FAX PROH.”.
- 2 Press **[▶]**.
- 3 Press **[+]** or **[=]** repeatedly to select “ON”.
- 4 Press **[SET]**.
- 5 Press **[STOP]** to exit the program.
 - While the junk fax prohibitor is activated, “JUNK FAX ON” is displayed.

4.8 Programming undesired callers

You can register up to 10 undesired numbers from the caller’s list if you do not wish to receive faxes from them.

- Keep the front cover page open for button locations.

- 1 Press **[MENU]** repeatedly to display “JUNK FAX PROH.”.
- 2 Press **[▶]** repeatedly to display “JUNK LIST SET”.
- 3 Press **[SET]**.
- 4 Press **[+]** or **[=]** repeatedly to display the entry you wish to prevent the fax reception from.
- 5 Press **[SET]**.
 - To program other entries, repeat steps 4 to 5.
- 6 Press **[STOP]** to exit the program.

Note:

- If there is no space to store new entries, “LIST FULL” is displayed in step 4. Erase unnecessary entries.

To display the junk fax prohibitor list

1. Press **[MENU]** repeatedly to display “JUNK FAX PROH.”.
2. Press **[▶]** repeatedly to display “JUNK LIST DISP.”.
3. Press **[SET]**.
4. Press **[+]** or **[=]** to display the entry.
5. To stop viewing, press **[STOP]**.
6. To exit the list, press **[STOP]**.

To print the junk fax prohibitor list

1. Press **[MENU]** repeatedly to display “JUNK FAX PROH.”.
2. Press **[▶]** repeatedly to display “JUNK LIST PRINT”.
3. Press **[SET]**.
4. Press **[STOP]** to exit the list.

To erase an entry from the junk fax prohibitor list

1. Press **[MENU]** repeatedly to display “JUNK FAX PROH.”.
2. Press **[▶]** repeatedly to display “JUNK LIST DISP.”.
3. Press **[SET]**.
4. Press **[+]** or **[=]** repeatedly to display the desired entry.
5. Press **[◀]**.
 - To cancel erasing, press **[STOP]**, then press **[MENU]**.
6. Press **[SET]**.
 - The entry is erased.
7. Press **[MENU]** to exit the list.

5.1 Distinctive Ring service from your phone company

The Distinctive Ring service is a service offered by your local telephone company. This service provides several telephone numbers for a single telephone line, and the ring pattern differs according to which telephone number the call was addressed to. Originally, this service was designed for the purpose of allowing different ring patterns to distinguish which number the call was addressed to.

This unit distinguishes the different ring patterns. If the ring pattern is one which is assigned for a fax, the fax machine will automatically start fax reception. This service is convenient if you wish to have a different number for fax in a single telephone line.

To use this service, you must subscribe to the Distinctive Ring service offered by your local telephone company.

5.2 Using two or more phone numbers in a single telephone line

5.2.1 Activating the Distinctive Ring feature

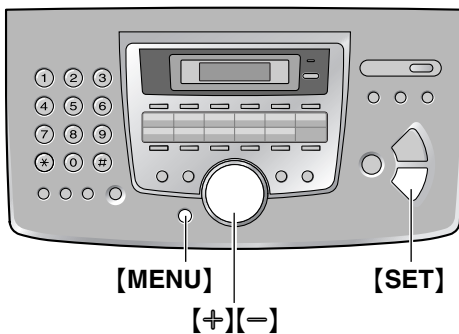

- 1 Press **[MENU]**.
- 2 Press **[#]**, then **[3][1]**.
- 3 Press **[+]** or **[-]** to select "ON".
- 4 Press **[SET]**.
- 5 Press **[MENU]** to exit the program.

How to receive calls

If the incoming call is for the fax number, the fax machine will ring with the assigned ring pattern and automatically start fax reception.

If the incoming call is for the phone number, the fax machine will keep on ringing.





5.3 Using three or more phone numbers in a single telephone line

You may wish to use three or more phone numbers for a single telephone line to distinguish which number the call was addressed to. A different ring pattern must be assigned for each number.

Example: Using three phone numbers

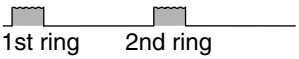
Telephone number	Ring pattern	Use
012 1234	Standard ring	Personal
012 5678	Double ring	Business
012 9876	Triple ring	Fax

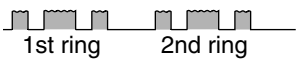
To use one phone number for the fax, program the ring pattern assigned for the fax in feature #32. In the example, the ring pattern assigned for fax is a triple ring, so you should program "C" (triple ring).

Ring pattern	Settings in feature #32
Standard ring (one long ring)  1st ring 2nd ring	A
Double ring (two short rings)  1st ring 2nd ring	B
Triple ring (short-long-short rings)  1st ring 2nd ring	C
Other triple ring (short-short-long rings)  1st ring 2nd ring	D

5.4 Programming the ring pattern assigned for fax

- Keep the front cover page open for button locations.
- 1 Set feature #31 to "ON" (page 42).
 - 2 Press **[MENU]**.
 - 3 Press **[#]**, then **[3][2]**.
 - 4 Press **[+]** or **[-]** repeatedly to select the ring pattern assigned for fax.
 - A:** Standard ring (one long ring)
 - B:** Double ring (two short rings)
 - C:** Triple ring (short-long-short-rings)
 - D:** Other triple ring (short-short-long rings)
 - B-D (default setting):** For the ring pattern of B, C and D
 - 5 Press **[SET]**.
 - 6 Press **[MENU]** to exit the program.

6.1 Making a copy

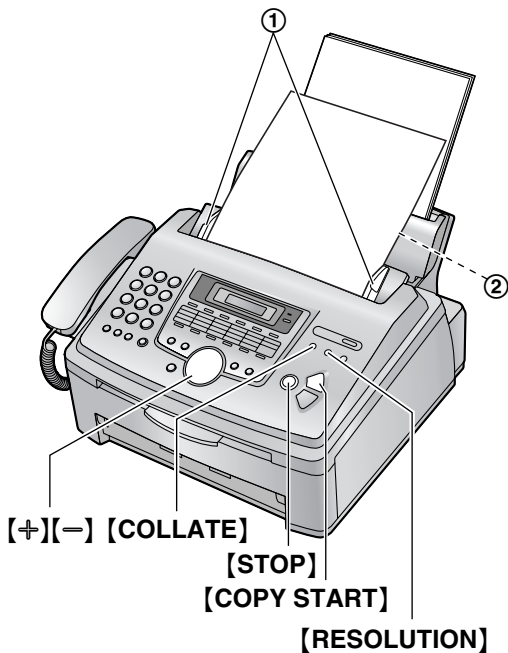

- 1 Adjust the width of the document guides (①) to the size of the document.
- 2 Insert the document (up to 20 pages) FACE DOWN (②) until a single beep is heard and the unit grasps the document.
- 3 If necessary, press **[RESOLUTION]** repeatedly to select the desired resolution.
- 4 Press **[COPY START]**.
 - If necessary, enter the number of copies (up to 99).
- 5 Press **[COPY START]**.
 - The unit will start copying.

Note:

- Any transmittable document can be copied (page 37).

To select the resolution

Select the desired resolution according to the type of document.

- “FINE”: For printed or typewritten originals with small printing.
- “SUPER FINE”: For originals with very small printing.
- “PHOTO”: For originals containing photographs, shaded drawings, etc.

- “PHOTO WITH TEXT”: For originals containing photographs and text.
- If you select “STANDARD”, copying will be done using “FINE” mode.

To stop copying

Press **[STOP]**.

6.1.1 More copying features

To enlarge a document

1. After step 4 on page 44, press **[+]** repeatedly to select from “105%” to “200%” by changing the enlargement rate 5% at a time.
2. Press **[COPY START]**.
 - The unit will only enlarge the center of the upper part of the document. To make an enlarged copy of the bottom of the document, turn the document around, and then make a copy.

Example: 150% enlarged copy

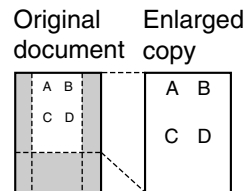

To reduce a document

1. After step 4 on page 44, press **[-]** repeatedly to select from “50%” to “95%” by changing the reduction rate 5% at a time.
2. Press **[COPY START]**.

Example: 70% reduced copy

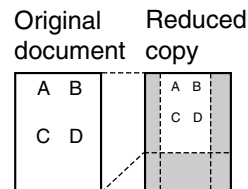

To collate multiple copies

The unit can collate multiple copies in the same order as the original document pages.

1. After step 3 on page 44, press **[COLLATE]** repeatedly to display “COLLATE ON”.
 - If necessary, enter the number of copies (up to 99).
2. Press **[COPY START]**.

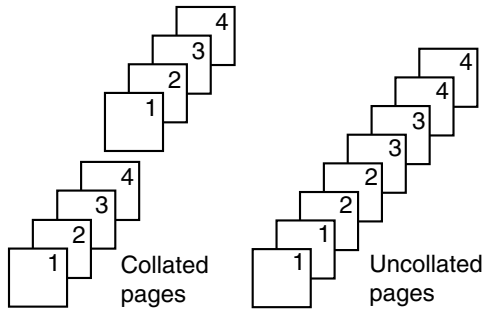
Example: Making 2 copies of a 4-page original document**Note:**

- The unit will store the documents into memory while collating the copies. If memory becomes full while storing, the unit will only print out the stored pages.
- After copying, the collating feature will turn OFF automatically.

7.1 Programming

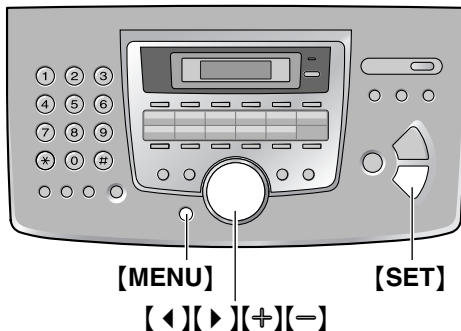

7.1.1 Programming basic features

- 1 Press **[MENU]**.
- 2 Select the feature you wish to program. Press **[◀]** or **[▶]** repeatedly to display the desired feature.
 - The current setting of the feature will be displayed.
- 3 Press **[+]** or **[-]** repeatedly to display the desired setting.
 - This step may be slightly different depending on the feature.
- 4 Press **[SET]**.
 - The setting you selected is set, and the next feature will be displayed.
- 5 To exit programming, press **[MENU]**.

7.1.2 Programming advanced features

- 1 Press **[MENU]**.
- 2 Press **[◀]** or **[▶]** repeatedly to display "ADVANCE SETTINGS".
- 3 Press **[SET]**.
- 4 Select the feature you wish to program. Press **[◀]** or **[▶]** repeatedly to display the desired feature.
 - The current setting of the feature will be displayed.
- 5 Press **[+]** or **[-]** repeatedly to display the desired setting.
 - This step may be slightly different depending on the feature.
- 6 Press **[SET]**.

- The setting you selected is set, and the next feature will be displayed.

- 7 To exit programming, press **[MENU]**.

To cancel programming

Press **[MENU]** to exit the program.

Programming by entering the program code number directly

You can select a feature by directly entering the program code (# and a 2-digit number) instead of using **[◀]** or **[▶]**.

1. Press **[MENU]**.
2. Press **[#]** and the 2-digit code number (page 46 to page 49).
3. Press **[+]** or **[-]** repeatedly to display the desired setting.
4. Press **[SET]**.
5. To exit programming, press **[MENU]**.

7.2 Basic features

Code #00: Setting the Quick Setup

```
QUICK SETUP
PRESS SET
```

See page 15 for details.

Code #01: Setting the date and time

```
SET DATE & TIME
PRESS SET
```

See page 28 for details.

Code #02: Setting your logo

```
YOUR LOGO
PRESS SET
```

See page 29 for details.

Code #03: Setting your fax number

```
YOUR FAX NO.
PRESS SET
```

See page 30 for details.

Code #04: Printing a sending report

```
SENDING REPORT
MODE=ERROR [±]
```

To print a sending report for fax transmission results (page 37).

"ERROR" (default): A sending report will be printed only when fax transmission fails.

“ON”: A sending report will be printed out after every transmission.

“OFF”: Sending reports will not be printed out.

Code #06: Changing the ring setting in FAX ONLY mode

```
FAX RING COUNT
RINGS=3      [±]
```

To change the number of rings before the unit answers a call in FAX ONLY mode.

You can select “1”, “2”, “3” (default), “4” or “5 EXT. TAM”.

Code #12: Enabling remote operation for an answering machine

```
REMOTE TAM ACT.
MODE=OFF     [±]
```

If you are using the unit with an answering machine, activate this feature, and program the remote activation ID to enable remote operation of the answering machine.

1. Press **[MENU]**.
2. Press **[#]** then **[1][2]**.
3. Press **[+]** or **[-]** repeatedly to select “ON”.
4. Press **[SET]**.
5. Enter your ID from 1 to 5 digits, using 0–9, **[*]** and **[#]**.
 - The default ID is “11”.
6. Press **[SET]**.
7. Press **[MENU]**.

Code #13: Setting the dialing mode

```
DIALING MODE
MODE=TONE    [±]
```

If you cannot dial, change this setting depending on your telephone line service.

“TONE” (default): For tone dial service.

“PULSE”: For rotary pulse dial service.

Code #16: Setting the recording paper size

```
PAPER SIZE
-LETTER      [±]
```

“LETTER” (default): Letter size paper.

“LEGAL”: Legal size paper.

“A4”: A4 size paper.

Code #17: Setting the ringer pattern

```
RINGER PATTERN
MODE=A       [±]
```

You can select “A” (default), “B” or “C”.

7.3 Advanced features

Code #22: Setting the journal report to print automatically

```
AUTO JOURNAL
MODE=ON      [±]
```

“ON” (default): The unit will print a journal report automatically after every 30 new fax communications (page 37).

“OFF”: The unit will not print a journal report, but will keep a record of the last 30 fax communications.

Code #23: Sending documents overseas

```
OVERSEAS MODE
MODE=ERROR   [±]
```

If you have difficulty sending an overseas fax, activate this feature before starting transmission.

- This feature is not available for broadcast transmission.
- The calling charge may be higher as the transmission speed is slowed down.

“NEXT FAX”: This setting is effective only for the next attempted fax transmission. After transmission, the unit will return to the previous setting.

“ERROR” (default): When the previous fax transmission fails and you wish to re-send the document automatically.

“OFF”: Deactivates this feature.

Code #25: Sending a fax at a specific time

```
DELAYED SEND
MODE=OFF     [±]
```

This feature allows you to take advantage of low-cost calling hours offered by your telephone company. This feature can be set up to 24 hours in advance of the desired time.

To send a document:

1. Insert the document.
2. Press **[MENU]**.
3. Press **[#]** then **[2][5]**.
4. Press **[+]** or **[-]** repeatedly to select “ON”.
5. Press **[SET]**.
6. Enter the fax number.
7. Press **[SET]**.
8. Enter the transmission start time.
 - Press **[*]** repeatedly to select “AM” or “PM”.
9. Press **[SET]**.

7. Programmable Features

- To cancel after programming, press **[STOP]** then **[SET]**.

Code #26: Setting the Caller ID list to print automatically

AUTO CALL. LIST MODE=ON [±]

“ON” (default): The unit will print the Caller ID list automatically after every 30 new calls (page 33).
“OFF”: The unit will not print the Caller ID list, but keep a record of the last 30 caller information.

Code #31: Activating the Distinctive Ring feature

DISTINCTIVE RING MODE=OFF [±]

See page 42 for details.

Code #32: Setting the ring pattern for fax (Distinctive Ring feature)

FAX RING PATTERN RING=B-D [±]

See page 43 for details.

Code #37: Receiving other size documents

AUTO REDUCTION MODE=ON [±]

To receive a fax document that is longer than your recording paper.

“ON” (default): The unit will fit received documents onto your recording paper.

“OFF”: The unit will print the original size.

Code #39: Changing the display contrast

LCD CONTRAST MODE=NORMAL [±]

“NORMAL” (default): For normal contrast.

“DARKER”: Used when the display contrast is too light.

Code #41: Changing the fax activation code

FAX ACTIVATION MODE=ON [±]

If you use an extension telephone and wish to use it to receive a fax, activate this feature and program the activation code.

1. Press **[MENU]**.
2. Press **[#]**, then **[4][1]**.
3. Press **[+]** or **[-]** repeatedly to select “ON”.
4. Press **[SET]**.
5. Enter your code from 2 to 4 digits, using 0–9, **[*]** and **[#]**.

- The default code is “*#9”.
- Do not enter “0000”.

6. Press **[SET]**.

7. Press **[MENU]**.

Code #44: Setting the memory reception alert

RECEIVE ALERT MODE=ON [±]

To alert you with a beeping sound when a received fax document is stored into memory due to some existing problem.

The slow beeps will continue until you clear the printing problem and make sure the unit is supplied with enough paper to print the stored document.

“ON” (default): You will hear a beeping sound.

“OFF”: Deactivates this feature.

Code #46: Setting friendly reception

FRIENDLY RCV MODE=ON [±]

To receive a fax automatically when you answer a call and hear a fax calling tone (slow beep).

“ON” (default): You do not have to press **[FAX START]** for fax reception.

“OFF”: You have to press **[FAX START]** for fax reception.

Code #68: Setting the Error Correction Mode (ECM)

ECM SELECTION MODE=ON [±]

This feature is available when the transmitting/receiving fax machines are ECM compatible.

“ON” (default): To send a fax even if there is static interference on the telephone line.

“OFF”: Deactivates this feature.

Code #76: Setting the connecting tone

CONNECTING TONE MODE=ON [±]

If you often have trouble when sending faxes, this feature allows you to hear connecting tones; fax tone, ring back tone and busy tone. You can use those tones to confirm the status of the other party's machine.

- If the ring back tone continues, the other party's machine may not be a facsimile or may have run out of paper. Check with the other party.
- The connecting tone volume cannot be adjusted.

“ON” (default): You will hear connecting tones.
 “OFF”: Deactivates this feature.

Code #79: Setting toner save feature

TONER SAVE	[±]
MODE=OFF	[±]

“ON”: The toner cartridge will last longer.
 “OFF” (default): Deactivates this feature.

Code #80: Resetting advanced features to their default settings

SET DEFAULT	[±]
RESET=NO	[±]

To reset the advanced features:

1. Press **[MENU]**.
2. Press **[*]**, then **[8][0]**.
3. Press **[+]** or **[-]** repeatedly to select “YES”.
4. Press **[SET]**.
5. Press **[SET]** again.
6. Press **[MENU]**.

7.4 Direct commands for programming features

You can also select the desired setting by directly entering the program code (# and a 2-digit number) and direct command.

- 1 Press **[MENU]**.
- 2 Press **[*]** and the 2-digit code number.
- 3 Press the desired direct command, using the dial keypad, to display the desired setting.
 - This step may be slightly different depending on the feature.
- 4 Press **[SET]**.
- 5 To exit programming, press **[MENU]**.

Program code and direct command key

[*][0][0] Quick Setup

- **[1]**: “FAX ONLY” (default)
- **[2]**: “DIST. RING”
- **[3]**: “EXT. TAM”
- **[4]**: “TEL ONLY”

- Press **[SET]** before pressing the direct command key.

[*][0][1] Date and time

- Enter the date and time using the dial keypad (see page 28 for details).

[*][0][2] Your logo

- Enter your logo using the dial keypad (see page 29 for details).

[*][0][3] Your fax number

- Enter your fax number using the dial keypad (see page 30 for details).

[*][0][4] Sending report

- **[1]**: “ON”
- **[2]**: “OFF”
- **[3]**: “ERROR” (default)

[*][0][6] Fax ring count

- **[1]**: “1”
- **[2]**: “2”
- **[3]**: “3” (default)
- **[4]**: “4”
- **[5]**: “5 EXT. TAM”

[*][1][2] Remote activation ID

- **[1]**: “ON”
- **[2]**: “OFF” (default)
- If you select “ON”, then enter your ID from 1 to 5 digits using 0-9, * and #.

[*][1][3] Dialing mode

- **[1]**: “PULSE”
- **[2]**: “TONE” (default)

[*][1][6] Paper size

- **[1]**: “LETTER” (default)
- **[2]**: “A4”
- **[3]**: “LEGAL”

[*][1][7] Ringer pattern

- **[1]**: “A” (default)
- **[2]**: “B”
- **[3]**: “C”

[*][2][2] Journal report

- **[1]**: “ON” (default)
- **[2]**: “OFF”

[*][2][3] Overseas mode

- **[1]**: “NEXT FAX”
- **[2]**: “OFF”
- **[3]**: “ERROR” (default)

[*][2][5] Delayed transmission

- **[1]**: “ON”
- **[2]**: “OFF” (default)
- If you select “ON”, then enter the fax number and transmission time using the dial keypad (see feature #25 on page 47 for details).

[*][2][6] Caller ID list

- **[1]**: “ON” (default)
- **[2]**: “OFF”

[*][3][1] Distinctive ring

- **[1]**: “ON”
- **[2]**: “OFF” (default)

7. Programmable Features

[*][3][2] Ring pattern

- **[1]**: "A"
- **[2]**: "B"
- **[3]**: "C"
- **[4]**: "D"
- **[5]**: "B-D" (default)

[*][3][7] Auto reduction

- **[1]**: "ON" (default)
- **[2]**: "OFF"

[*][3][9] Display contrast

- **[1]**: "NORMAL" (default)
- **[2]**: "DARKER"

[*][4][1] Fax activation code

- **[1]**: "ON" (default)
- **[2]**: "OFF"
- If you select "ON", then enter your code from 2 to 4 digits using 0-9, *, and #.

[*][4][4] Memory reception alert

- **[1]**: "ON" (default)
- **[2]**: "OFF"

[*][4][6] Friendly reception

- **[1]**: "ON" (default)
- **[2]**: "OFF"

[*][6][8] ECM selection

- **[1]**: "ON" (default)
- **[2]**: "OFF"

[*][7][6] Connecting tone

- **[1]**: "ON" (default)
- **[2]**: "OFF"

[*][7][9] Toner save

- **[1]**: "ON"
- **[2]**: "OFF" (default)

[*][8][0] Reset advanced features

- **[1]**: "YES"
- **[2]**: "NO" (default)
- If you select "YES", press **[SET]** 2 times, then press **[MENU]** to exit programming.

8.1 Error messages – Reports

If a problem occurs during fax transmission or reception, one of the following communication messages will be printed on the sending and journal reports (page 37).

COMMUNICATION ERROR

(Code: 40-42, 46-72, FF)

- A transmission or reception error occurred. Try again or check with the other party.

COMMUNICATION ERROR

(Code: 43, 44)

- A line problem occurred. Connect the telephone line cord to a different jack and try again.
- An overseas transmission error occurred. Try using the overseas mode (feature #23, page 47).

DOCUMENT JAMMED

- The document is jammed. Remove the jammed document (page 60).

ERROR-NOT YOUR UNIT

(Code: 54, 59, 70)

- A transmission or reception error occurred because of a problem with the other party's fax machine. Check with the other party.

JUNK FAX PROH. REJECT

- The junk fax prohibitor of your fax machine rejected fax reception.

MEMORY FULL

- The memory is full of received documents due to a lack of recording paper or a recording paper jam. Install paper (page 13) or clear the jammed paper (page 58).

NO DOCUMENT

- The document was not fed into the unit properly. Re-insert the document and try again.

OTHER FAX NOT RESPONDING

- The other party's fax machine is busy or has run out of recording paper. Try again.
- The document was not fed properly. Re-insert the document and try again.
- The other party's fax machine rings too many times. Send the fax manually (page 36).
- The other party's machine is not a fax machine. Check with the other party.
- The number you dialed is not in service.

PRESSED THE STOP KEY

- [STOP] was pressed and fax communication was canceled.

THE COVER WAS OPENED

- The front cover was opened. Close it and try again.

OK

- Fax communication was successful.

8.2 Error messages – Display

If the unit detects a problem, one or more of the following messages will appear on the display.

CALL SERVICE

- There is something wrong with the unit. Contact our service personnel.

CHANGE DRUM

- There is something wrong with the drum unit. Replace the drum unit and the toner cartridge (page 56).

CHECK DOCUMENT

- The document was not fed into the unit properly. Re-insert the document. If misfeeding occurs frequently, clean the document feeder rollers (page 61) and try again.

CHECK DRUM

- The drum unit is not inserted properly. Re-insert it correctly (page 10).

CHECK MEMORY

- The memory (telephone numbers, parameters, etc.) has been erased. Re-program.

COVER OPEN

- The front cover is open. Close it.

DIRECTORY FULL

- There is no space to store new entries in navigator directory. Erase unnecessary entries (page 32).

DRUM LIFE OVER
REPLACE DRUM

8. Help

- The drum life is complete. Replace the drum unit immediately (page 56).

FAILED PICK UP

- Recording paper was not fed into the unit properly. Re-insert the recording paper (page 58).

FAX IN MEMORY

- The unit has a document in memory. See the other displayed message instructions to print out the document.

FAX MEMORY FULL

- The memory is full of received documents due to a lack of recording paper or a recording paper jam. Install paper (page 13) or clear the jammed paper (page 58).
- When performing memory transmission, the document being stored exceeded the memory capacity of the unit. Transmit the entire document manually.

LOW TEMP.

- The inside of the unit is extremely cold and cannot be operated. Use the unit in a warmer area. While the unit cannot be operated, the received documents are temporarily stored into the memory, and will be printed out automatically when the unit warms up.

MEMORY FULL

- When making a copy, the document being stored exceeded the memory capacity of the unit. Press **[STOP]** to clear the message. Divide the document into sections.

MODEM ERROR

- There is something wrong with the modem circuit. Contact our service personnel.

NO FAX REPLY

- The other party's fax machine is busy or has run out of recording paper. Try again.

OUT OF PAPER

- Recording paper is not installed or the unit has run out of paper. Install paper (page 13).

- Recording paper is not fed into the unit properly. Reinstall paper (page 13).

PAPER JAMMED

- A recording paper jam occurred. Clear the jammed paper (page 58).

PLEASE WAIT

- The unit is warming up. Wait for a while.

REDIAL TIME OUT

- The other party's fax machine is busy or has run out of recording paper. Try again.

REMOVE DOCUMENT

- The document is jammed. Remove the jammed document (page 60).
- Attempted to transmit a document longer than 600 mm (23⁵/₈"). Press **[STOP]** to remove the document. Divide the document into two or more sheets and try again.

REPLACE DRUM SOON

- The drum life is near to an end. Replace the drum unit as soon as possible (page 56).

TONER EMPTY

- The toner life is complete. Replace the toner cartridge immediately (page 56).

TONER LOW

- The toner life is near to an end. Replace the toner cartridge as soon as possible (page 56).

TRANSMIT ERROR

- A transmission error occurred. Try again.

WARM UP

- The inside of the unit is too cold. Let the unit warm up. Wait for a while.

WRONG PAPER

- The fax message was printed on paper which is shorter than letter size paper. Use the appropriate size paper (page 68).

8.3 When a function does not work, check here

8.3.1 General

I cannot make and receive calls.

- The power cord or telephone line cord is not connected. Check the connections.
- If you used a splitter to connect the unit, remove the splitter and connect the unit to the wall jack directly. If the unit operates properly, check the splitter.

I cannot make calls.

- The dialing mode setting is wrong. Change the setting of feature #13 (page 47).

The unit does not work.

- Disconnect the unit from the telephone line and connect the line to a known working telephone. If the working telephone operates properly, contact our service personnel to have the unit repaired. If the working telephone does not operate properly, contact your telephone company.

The unit does not ring.

- The ringer volume is turned OFF. Adjust it (page 27).

The other party complains they only hear a fax tone and cannot talk.

- FAX ONLY mode is set. Tell the other party the number is only used for faxes.
- Change to TEL mode by pressing [**AUTO ANSWER**].
- If you use a Distinctive Ring service, make sure you have set the same ring pattern assigned by the telephone company (page 42).

The [**REDIAL/PAUSE**] button does not function properly.

- If this button is pressed during dialing, a pause will be inserted. If pressed immediately after a dial tone is obtained, the last number dialed will be redialed.

The receiving mode does not function properly.

- The Distinctive Ring is set (feature #31, page 42).

During programming, I cannot enter the code or ID number.

- All or part of the numbers are the same. Change the number: feature #12 (page 47) and #41 (page 48).

The unit beeps.

- Recording paper has run out. Press [**STOP**] to stop the beeps and install paper.

Whenever I try to retrieve my voice mail messages, the retrieval is interrupted by the fax tone.

- You are probably entering ✕#9. This is the default setting for the fax activation code. If you use a voice mail service, turn the fax activation feature OFF or reprogram the activation code (feature #41 on page 48).

8.3.2 Fax – sending

I cannot send documents.

- The telephone line cord is connected to the EXT jack on the unit. Connect to the LINE jack (page 15).
- The other party's fax machine is busy or has run out of recording paper. Try again.
- The other party's machine is not a fax machine. Check with the other party.
- The other party's fax machine rings too many times. Send the fax manually (page 36).

The other party complains that letters on their received document are distorted or not clear.

- If your line has special telephone services such as call waiting, the service may have been activated during fax transmission. Connect the unit to a line that does not have these services.
- An extension telephone on the same line is off the hook. Hang up the extension telephone and try again.
- Try copying the document. If the copied image is clear, there may be something wrong with the other party's machine.

The other party complains that smudges or black lines appear on their received document.

- The glass or rollers are dirty. Clean them (page 61).

I cannot send a fax overseas.

- Use the overseas transmission mode of feature #23 (page 47).

8. Help

- Add two pauses at the end of the telephone number or dial manually.

8.3.3 Fax – receiving

I cannot receive documents.

- The telephone line cord is connected to the EXT jack on the unit. Connect to the LINE jack (page 15).
- When you have a single telephone line and subscribe to a voice mail service, you must also subscribe to a Distinctive Ring service (page 42).

I cannot receive documents automatically.

- The receiving mode is set to TEL mode. Set to FAX ONLY mode by pressing **[AUTO ANSWER]**.
- The time taken to answer the call is too long. Decrease the number of rings in feature #06 (page 47).

The display shows “CONNECTING”, but faxes are not received.

- The incoming call is not a fax. Change the receiving mode to TEL mode by pressing **[AUTO ANSWER]**.

A blank sheet is ejected.

- The other party placed the document in their fax machine the wrong way. Check with the other party.

A white line or a smudge appears on your recording paper.

- The glass or rollers are dirty. Clean them (page 61).

The printing quality is poor.

- The other party sent a faint document. Ask them to send a clearer copy of the document.
- Some paper has instructions recommending which side to print on. Try turning the paper over.
- You may have used paper with a cotton and/or fiber content that is over 20%, such as letterhead or resume paper.
- The remaining toner is low. Replace the toner cartridge (page 56).
- We recommend you replace the drum unit every fourth time you replace the toner cartridge (page 56). To check the drum life and quality, please print the printer test list (page 66).
- The toner save mode is ON (feature #79, page 49).

The other party complains that they cannot send a document.

- The memory is full of received documents due to a lack of recording paper or a recording paper jam. Install paper (page 13) or clear the jammed paper (page 58).
- The unit is not in FAX ONLY mode. Press **[AUTO ANSWER]** repeatedly to turn ON the AUTO ANSWER light.

I cannot select the desired receiving mode.

- If you want to set FAX ONLY mode:
 - press **[AUTO ANSWER]** repeatedly to turn ON the AUTO ANSWER light.
- If you want to set TEL mode:
 - press **[AUTO ANSWER]** repeatedly to turn OFF the AUTO ANSWER light.
- The Distinctive Ring of feature #31 is activated (page 42).

8.3.4 Copying

The unit will not make a copy.

- You cannot make a copy during programming. Make the copy after programming.

A black line, a white line or smudge appears on the copied document.

- The glass or rollers are dirty. Clean them (page 61).

The printing quality is poor.

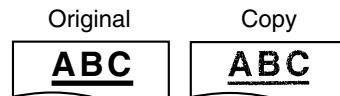

- Some paper has instructions recommending which side to print on. Try turning the paper over.
- You may have used paper with a cotton and/or fiber content that is over 20%, such as letterhead or resume paper.
- The remaining toner is low. Replace the toner cartridge (page 56).
- We recommend you replace the drum unit every fourth time you replace the toner cartridge (page 56). To check the drum life and quality, please print the printer test list (page 66).
- The toner save mode of feature #79 is ON (page 49).

8.3.5 Using an answering machine

out stating which contents in the memory have been erased.

I cannot receive documents automatically.

- Your greeting message on the answering machine is too long. Shorten the message. Record a message up to 10 seconds long.
- The answering machine rings too many times. Set to 1 or 2 rings.

I cannot receive voice messages.

- Check if the answering machine is turned ON and connected to the fax machine properly (page 21).
- Set the number of rings on the answering machine to 1 or 2.

I cannot retrieve recorded voice messages on the answering machine from a remote location.

- You did not program your remote access code into your fax machine correctly. Program the same code that is programmed on the answering machine on the fax machine with feature #12 (page 47).

I pressed the remote access code to access the answering machine remotely, but the line was disconnected.

- The code may include “#” which is used for certain features provided by telephone companies. Change the code on the answering machine to another number which does not include “#”. Also change the code of the fax machine with feature #12 (page 47).

Callers complain that they cannot send a document.

- Your answering machine has run out of recording tape. Rewind the tape to record messages.
- You set the answering machine to only give a greeting message.

8.3.6 If a power failure occurs

- The unit will not function.
- The unit is not designed for making emergency telephone calls when the power fails. Alternative arrangements should be made for access to emergency services.
- Fax transmission and reception will be interrupted.
- If any fax documents are stored in the memory, they will be lost. When power is restored, a power down report will be printed

8.4 Replacing the toner cartridge and the drum unit

When the display shows the following, replace the toner cartridge.

TONER LOW

TONER EMPTY

We recommend you replace the drum unit every fourth time you replace the toner cartridge. To check the drum life and quality, please print the printer test list (page 66). To ensure that the unit operates properly, we recommend the use of **Panasonic toner cartridge (Model No. KX-FA83) and drum unit (Model No. KX-FA84)**. See page 8 for accessory information.

Caution:

- We cannot be responsible for any damage to the unit or degradation of print quality which may occur from the use of a non-Panasonic toner cartridge and drum unit.
- The drum unit contains a photosensitive drum. Exposing it to light may damage the drum.

Once you have opened the protection bag:

- Do not expose the drum unit to light for more than 5 minutes.
- Do not touch or scratch the green drum surface.
- Do not place the drum unit near dust or dirt, or in a high humidity area.
- Do not expose the drum unit to direct sunlight.
- Do not unplug the fax machine. Loss of fax documents in memory may occur.
- Do not leave the toner cartridge out of the protection bag for a long time. It will decrease the toner life.
- Do not add toner to the toner cartridge.

- 1 Before opening the protection bag of the new toner cartridge, shake it vertically more than 5 times.



- 2 Remove the new toner cartridge from the protection bag. Peel off the seal (1) from the toner cartridge.

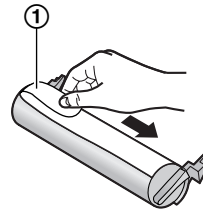

- 3 Lift open the front cover (1), holding OPEN (2).

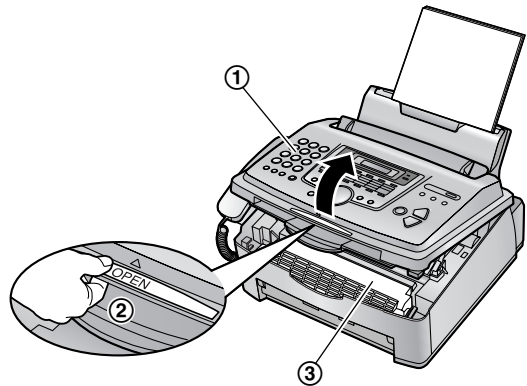

Caution:
The fuser unit (3) gets hot. Do not touch it.

- 4 Tap on the used toner cartridge several times to allow the remaining toner to fall into the

drum unit. Remove the drum and toner unit (①) by holding the two tabs (②).

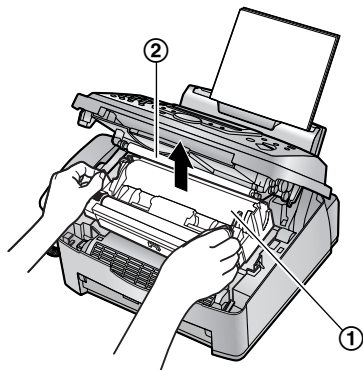

- Do not touch the transfer roller (②).
- If you replace the toner cartridge and the drum unit at the same time, skip to step 7.

5 Turn the two levers (①) on the used toner cartridge firmly, until the triangles (②) match.

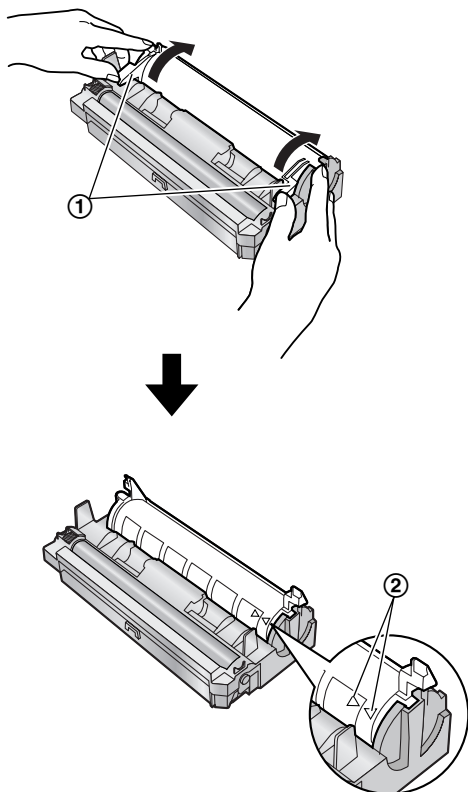

6 Remove the used cartridge (①) from the drum unit (②).

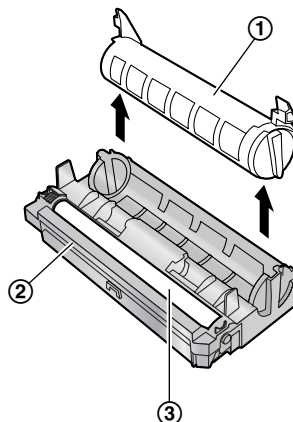

- The toner may stick to the cartridge and the drum unit. Be careful when handling. See page 4 for details.
- Do not drop the toner on the green drum surface (③).
- Put the used toner cartridge into the protection bag.

7 If you replace the drum unit at the same time, remove the new drum unit from the protection bag.

Place the new toner cartridge (①) into the drum unit (②) vertically.

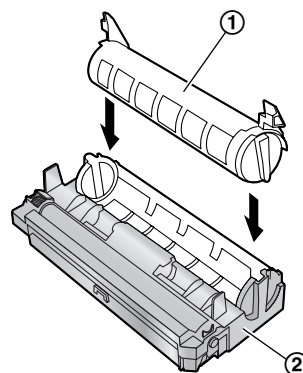

8 Firmly press down the toner cartridge to snap into position (①).

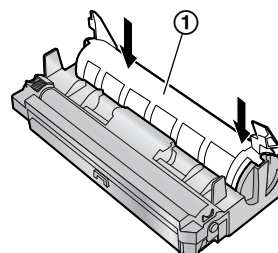

8. Help

- 9 Turn the two levers (①) on the toner cartridge firmly.

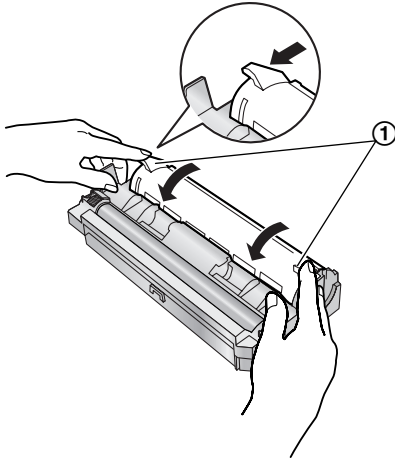

- 10 Make sure that the triangles (①) match, to install the toner cartridge correctly.

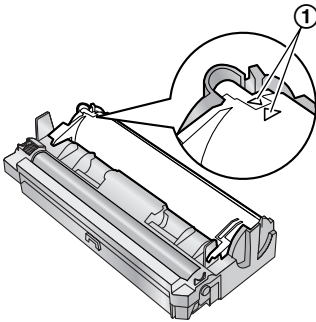

- 11 Install the drum and toner unit (①) by holding the tabs.

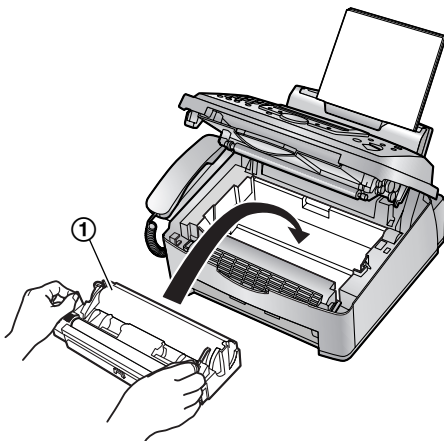

- If the lower glass (②) is dirty, clean it with a soft and dry cloth.

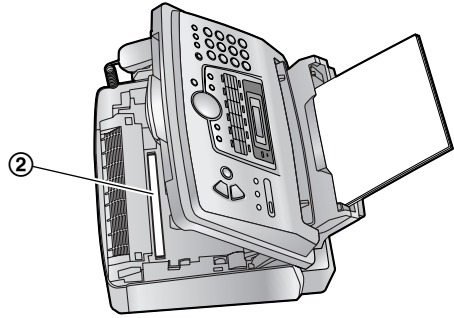

- 12 Close the front cover (①) by pushing down on both sides, until locked.

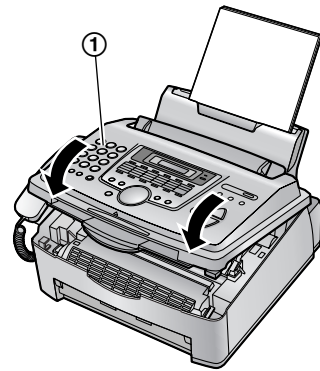

- While the unit displays “PLEASE WAIT”, do not open the front cover, or disconnect the power cord.

Waste disposal method

Waste material should be dumped or incinerated under conditions which meet all national and local environmental regulations.

8.5 Recording paper jam

8.5.1 When the recording paper has jammed in the unit

The display will show the following.

PAPER JAMMED

- 1 Lift open the front cover (①), holding OPEN (②).

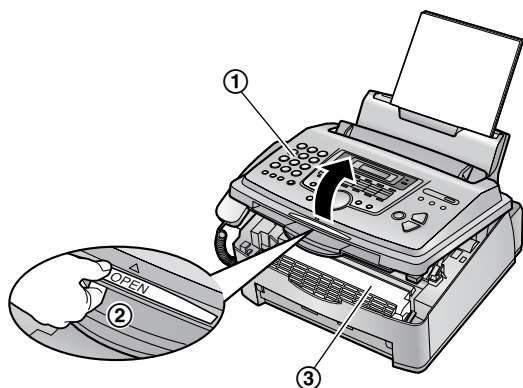

Caution:
The fuser unit (③) gets hot. Do not touch it.

- 2 Remove the jammed paper.

When the recording paper has jammed near the drum and toner unit:

Remove the jammed paper (①) carefully by pulling it toward you.

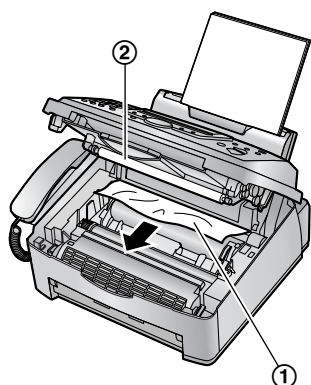

- Do not touch the transfer roller (②).

When the recording paper has jammed near the recording paper exit:

1. Remove the recording paper (①), then remove the drum and toner unit (②) to

allow the jammed paper (③) to pull free from the rear cabinet.

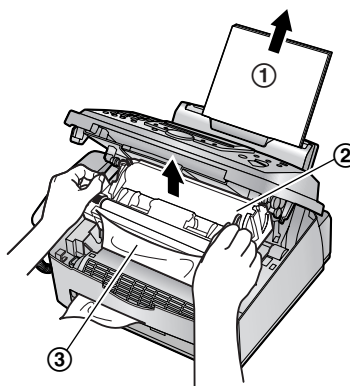

2. Lift both green levers (①) forward until they stop.

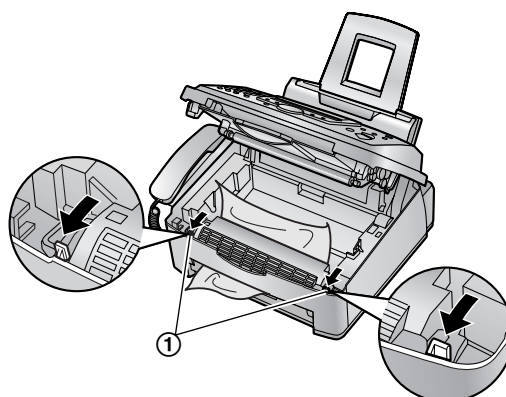

3. Remove the jammed paper (①) from the fuser unit by pulling it upwards carefully, then install the drum and toner unit.

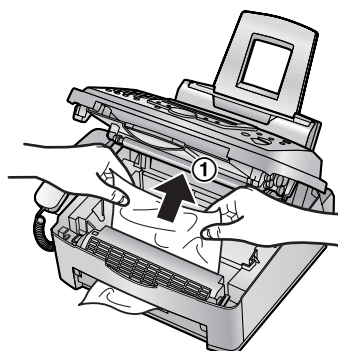

4. Push back the levers (①) to the original position.

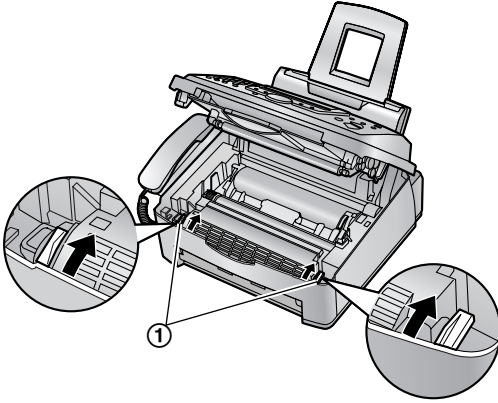

3. Close the front cover (①) by pushing down on both sides, until locked. Pull the tension plate forward (②) and re-insert the recording paper (③), then push back the tension plate.
 - Before re-inserting, make sure to fan and straighten the recording paper.

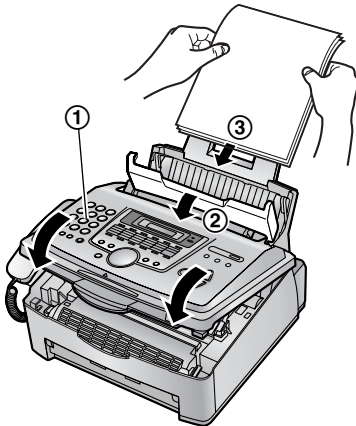

- Before re-inserting, make sure to fan and straighten the recording paper.



8.6 Document jams - sending

1. Lift open the front cover (①), holding OPEN (②).

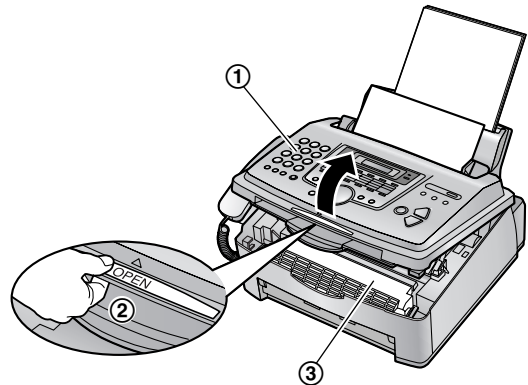

8.5.2 When the recording paper is not fed into the unit properly

The display will show the following.

FAILED PICK UP

Remove the recording paper. Pull the tension plate forward (①) and re-insert the recording paper (②), then push back the tension plate.



Caution:
The fuser unit (③) gets hot. Do not touch it.

- 2 Hold the center part of the front cover (①), and pull open the inner cover (②).

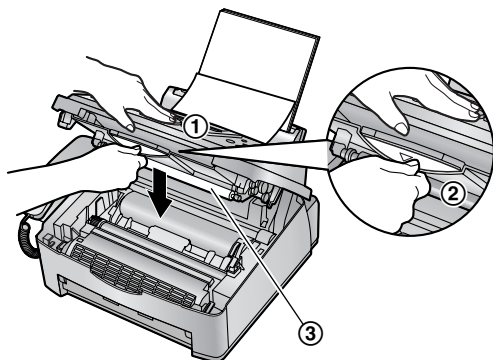

- Do not touch the transfer roller (③).

- 3 Remove the jammed document carefully (①).

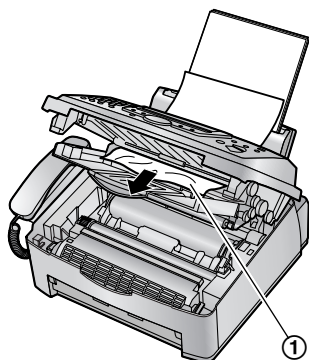

- 4 Push back the inner cover.
- 5 Close the front cover (①) by pushing down on both sides, until locked.

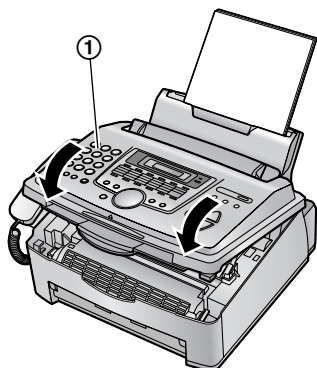

Note:

- Do not pull out the jammed document forcibly before opening the front cover.

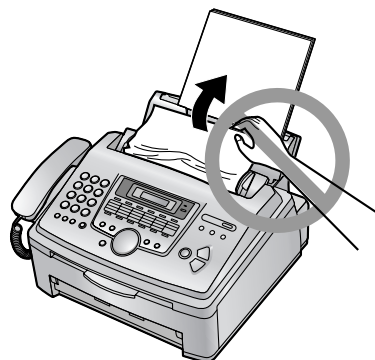

8.7 Cleaning the inside of the unit

If any of the following problems occurs, clean the inside of the unit:

- If misfeeding of your original occurs frequently.
- If a black line, a white line or a dirty pattern appears on your recording paper, on your original, or on the fax document received by the other party.

Caution:

- **Be careful when handling the drum and toner unit.** See the caution for the drum unit on page 56 for details.
- **Do not use paper products, such as paper towels or tissues, to clean the inside of the unit.**

- 1 Disconnect the power cord and the telephone line cord.
- 2 Lift open the front cover (①), holding OPEN (②).

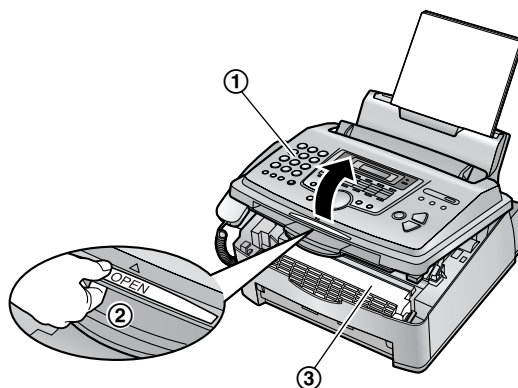

8. Help



Caution:
The fuser unit (③) gets hot. Do not touch it.

- 3 Clean the document separation roller (①) with a cloth moistened with isopropyl rubbing alcohol, and let all parts dry thoroughly.

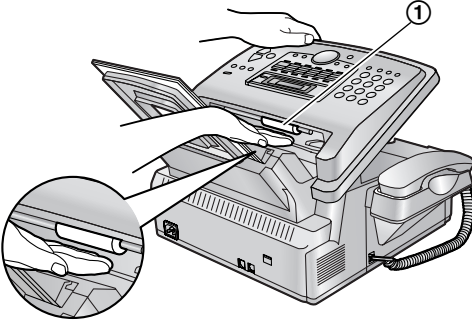

- 4 Hold the center part of the front cover (①), and pull open the inner cover (②).

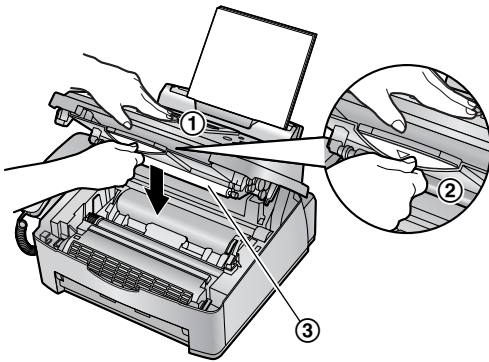

- Do not touch the transfer roller (③).

- 5 Clean the document feeder roller (①) with a cloth moistened with isopropyl rubbing alcohol, and let all parts dry thoroughly. Clean the upper glass (②) with a soft and dry cloth.

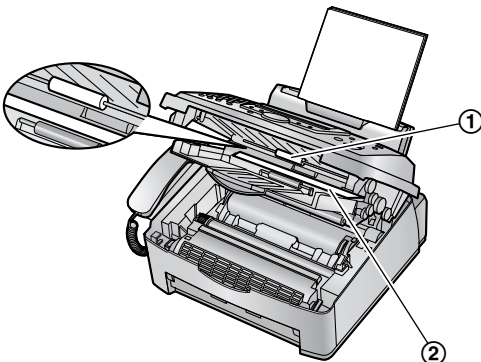

- 6 Push back the inner cover.

- 7 Remove the drum and toner unit (①) by holding the two tabs.

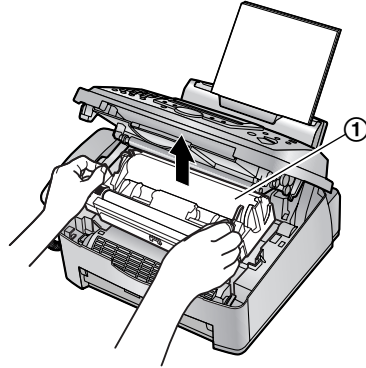

- 8 Clean the lower glass (①) with a soft and dry cloth.

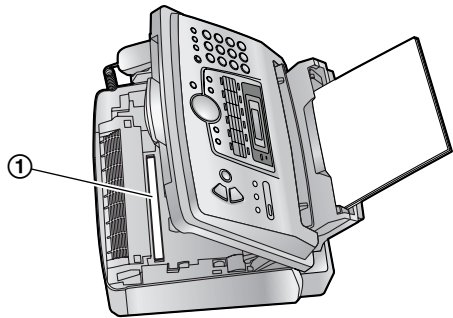

- 9 Reinstall the drum and toner unit (①) by holding the tabs.

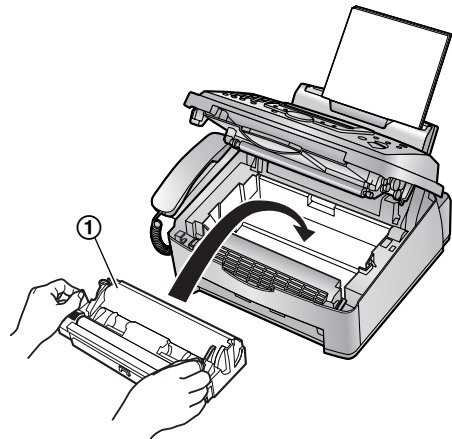

10 Close the front cover (①) by pushing down on both sides, until locked.

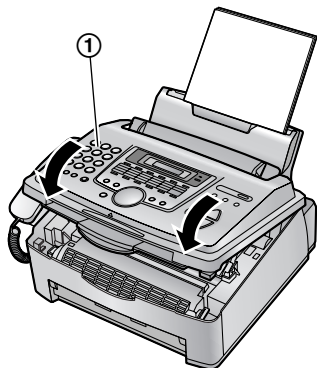

11 Reconnect the power cord and the telephone line cord.

Note:

- Do not touch the transfer roller (①).

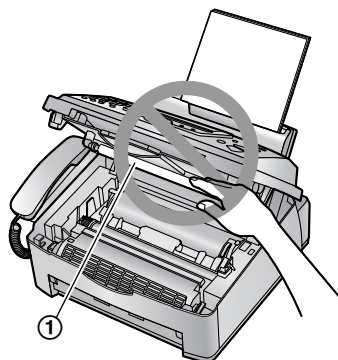

9.1 openLCR service for the Caller IQ feature

This unit is compatible with service provided by openLCR.

- If you have any questions regarding the openLCR service, call openLCR's customer service department at 1-866-openLCR (1-866-673-6527).
- NEITHER PANASONIC COMMUNICATIONS CO., LTD. (PCC) NOR MATSUSHITA ELECTRIC CORPORATION OF AMERICA (MECA) IS IN ANY WAY AFFILIATED WITH, OR RESPONSIBLE FOR THE ACTS OR OMISSIONS OF, OPENLCR.COM, INC. (OPENLCR). NEITHER PCC NOR MECA NOR ANY OF THEIR EMPLOYEES OR AFFILIATES OR CUSTOMERS MAKE ANY WARRANTIES OR REPRESENTATIONS, EITHER EXPRESS OR IMPLIED, TO ANY CUSTOMER OR ANY OTHER THIRD PARTY WITH RESPECT TO ANY OF THE SERVICES PROVIDED BY OPENLCR, NOR ASSUME NOR CREATE ANY OTHER OBLIGATION OF ANY KIND ON BEHALF OF OPENLCR.
- If you subscribe to openLCR service, the unit will start the first download of the rate table to your fax machine and the Caller IQ feature will be automatically turned ON. The CALLER IQ indicator will stay on. No special dialing or button pressing is necessary to place a long distance call with the Caller IQ feature.
If you do not wish to use the Caller IQ feature, you can turn it OFF temporarily.

Note:

- Before subscribing to openLCR service, you cannot change the following settings.

9.2 To turn the Caller IQ ON / OFF

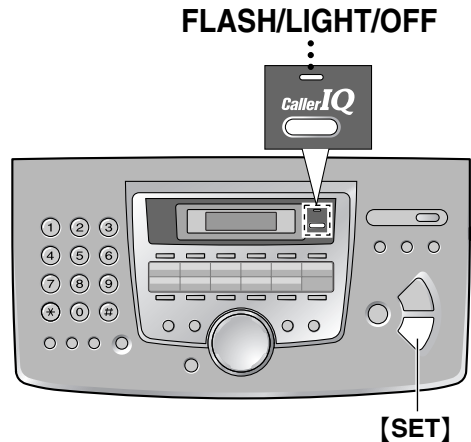

- 1 Press [**CALLER IQ**].
- 2 Press [**0**].
- 3 To turn **ON**:
Press [**1**].
To turn **OFF**:
Press [**3**].
- 4 Press [**SET**].
 - When the Caller IQ feature is turned ON, the CALLER IQ indicator will turn ON.
 - When the Caller IQ feature is turned OFF, the CALLER IQ indicator will turn OFF.

9.3 Updating the rate table (downloading the rate table)

If you register through the openLCR web site or move to another area, you have to download the rate table manually.

- Keep the front cover page open for button locations.
- 1 Press [**CALLER IQ**].
 - 2 Press [**††**].
 - 3 Press [**SET**].
 - 4 Follow the voice prompt to start downloading.

During download

- The CALLER IQ indicator will flash and the display will show the following.

DOWNLOADING

- While downloading, you cannot do other operations such as making/answering calls or sending/receiving documents.
- Depending on where you live, the call for downloading may be a long distance call and will take about 1-2 minutes. You will be charged for the cost of the call.
- When the download is completed, the CALLER IQ indicator will stop flashing but will remain lit up and the display will show "DOWNLOAD OK!"
- If "DOWNLOAD ERROR. TRY AGAIN." is displayed, the unit was unable to download from openLCR. Try downloading manually again.

Automatic download

The fax machine will automatically download the latest rate table when:

- the rate table in the fax machine reaches the expiry date; usually between 60-90 days after last update,
- the fax machine is being polled by openLCR service center.

To stop downloading

1. Press **[STOP]**.
2. Press **[SET]**.

9.4 Downloading information

This enables you to view information such as weather, lottery results and stock quotes on the LCD display. Each time you download the data from openLCR, the information will be updated. To view up-to-date information, you will need to download the information to your unit.

If you access the openLCR web site at **www.openLCR.com** and program the system setup and phone book, you will need to download this data to the fax machine.

- Keep the front cover page open for button locations.

- 1 Press **[CALLER IQ]**.
- 2 Press **[#]**.
- 3 Press **[SET]**.

- 4 Follow the voice prompt to start downloading.

9.5 Viewing information

- Keep the front cover page open for button locations.

- 1 Press **[CALLER IQ]**.
- 2 Press **[2]**.
- 3 Press **[SET]**.
 - The items of information which you selected on the web are displayed.

Example:

openLCR.com
1: Weather

↑↓

2: Stock

- 4 Select the desired information by pressing the desired information number, using the dial keypad.
- 5 Press **[+]** or **[-]** repeatedly to find more information.
- 6 Press **[CALLER IQ]** to stop viewing.

9.6 Printing information

- Keep the front cover page open for button locations.

- 1 Press **[CALLER IQ]**.
- 2 Press **[1]**.
- 3 Press **[SET]** to start printing.

10.1 Reference lists and reports

You can print out the following lists and reports for your reference.

Setup list:

Provides you with the current settings of the basic and advanced programming features (page 46 to page 49).

Telephone number list:

Provides you with names and numbers which are stored in one-touch dial and the navigator directory.

Journal report:

Keeps records of fax transmission and reception. This report will be printed automatically after every 30 fax communications (feature #22, page 47).

Broadcast programming list:

Provides you with names and numbers which are stored in the broadcast memory (page 38).

Printer test:

Allows you to check the print quality of your unit. If the test print has a dirty pattern, or blurred points or lines, clean the inside of the unit (page 61). If printing quality is still poor, replace the toner cartridge and drum unit.

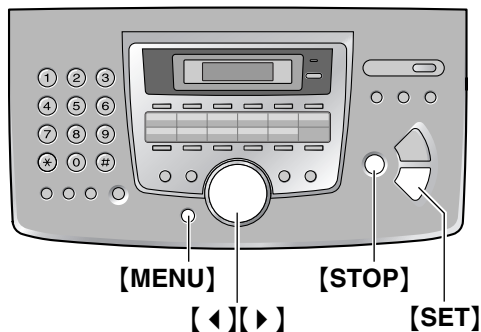

- 1 Press **[MENU]** repeatedly to display "PRINT REPORT".
- 2 Press **[◀]** or **[▶]** repeatedly to display the desired item.
- 3 Press **[SET]** to start printing.
 - To stop printing, press **[STOP]**.
- 4 Press **[MENU]**.

10.2 Technical data about this product

Applicable lines:	Public Switched Telephone Network
Document size:	Max. 216 mm (8 ¹ / ₂ ") in width, Max. 600 mm (23 ⁵ / ₈ ") in length
Effective scanning width:	208 mm (8 ³ / ₁₆ ")
Effective printing width:	Letter/Legal: 208 mm (8 ³ / ₁₆ ") A4: 202 mm (7 ¹⁵ / ₁₆ ")
Transmission time^{*1}:	Approx. 8 s/page (ECM-MMR) ^{*2}
Scanning density:	Horizontal: 8 pels/mm (203 pels/inch) Vertical: 3.85 lines/mm (98 lines/inch) – in standard resolution, 7.7 lines/mm (196 lines/inch) – in fine/photo resolution, 15.4 lines/mm (392 lines/inch) – in super fine resolution
Photo resolution:	64-level
Scanner type:	Contact Image Sensor
Printer type:	Laser Beam Printer
Data compression system:	Modified Huffman (MH), Modified READ (MR), Modified Modified READ (MMR)
Modem speed:	14,400 / 12,000 / 9,600 / 7,200 / 4,800 / 2,400 bps; Automatic Fallback
Operating environment:	10°C – 32.5°C (50°F – 90.5°F), 20% – 80% RH (Relative Humidity)
Dimensions:	Approx. height 220 mm × width 430 mm × depth 360 mm (8 ²¹ / ₃₂ " × 16 ¹⁵ / ₁₆ " × 14 ⁵ / ₃₂ ")
Mass (Weight):	Approx. 9.0 kg (19.8 lb.)
Power consumption:	Standby: Approx. 3 W Transmission: Approx. 11 W Reception: Approx. 290 W Copy: Approx. 290 W Maximum: Approx. 900 W (When the fuser lamp turns on)
Power supply:	120 V AC, 60 Hz
Fax memory capacity:	Approx. 120 pages of memory transmission Approx. 170 pages of memory reception (Based on the ITU-T No. 1 Test Chart in standard resolution.)
Laser diode properties:	Laser output: Max. 5 mW Wave length: 760 nm – 800 nm Emission duration: Continuous
Print speed:	Approx. 12 ppm (pages per minute)
Printing resolution:	600 × 600 dpi

*1 Transmission speed depends upon the contents of the pages, resolution, telephone line conditions and capability of the other party's machine.

*2 Transmission speed is based upon the ITU-T No. 1 Test Chart. If the capability of the other party's machine is inferior to your unit, the transmission time may be longer.

ITU-T No. 1 Test Chart

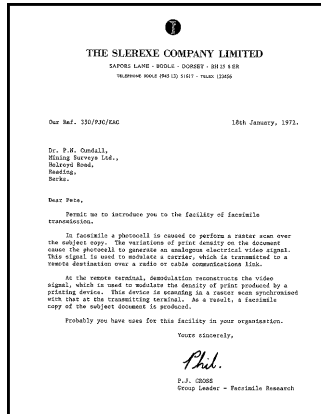

Paper specifications

Recording paper size:	Letter: 216 mm × 279 mm (8 ¹ / ₂ " × 11") Legal: 216mm × 356 mm (8 ¹ / ₂ " × 14") A4: 210 mm × 297 mm (8 ¹ / ₄ " × 11 ¹¹ / ₁₆ "
Recording paper weight:	60 g/m ² to 90 g/m ² (16 lb. to 24 lb.)

Note for recording paper:

- Do not use the following types of paper:
 - Paper with a cotton and/or fiber content that is over 20%, such as letterhead paper or paper used for resumes
 - Extremely smooth or shiny paper, or paper that is highly textured
 - Coated, damaged or wrinkled paper
 - Paper with foreign objects attached, such as tabs or staples
 - Paper which has dust, lint or oil stains
 - Paper that will melt, vaporize, discolor, scorch or emit dangerous fumes near 200°C (392°F), such as vellum paper. These materials may transfer onto the fusing roller and cause damage.
 - Moist paper
 - Inkjet paper
- Some paper only accepts print on one side. Try using the other side of the paper if you are not happy with the print quality or if misfeeding occurs.
- For proper paper feeding and best print quality, we recommend using long-grained paper.
- Do not use paper of different types or thickness at the same time. This may cause a paper jam.
- Avoid double-sided printing.
- Do not use paper printed from this unit for double-sided printing with other copiers or printers. This may cause a paper jam.
- To avoid curling, do not open paper packs until you are ready to use the paper. Store unused paper in the original packaging, in a cool and dry location.

Toner life

Toner life depends on the amount of content in a received, copied or printed document. The following is the approximate relationship between image area and toner life for replacement toner cartridge (Model No. KX-FA83). Toner life varies in actual usage.

5% image area

Specifications	
Main unit specifications	
1. Applicable Lines:	Public switched telephone network
2. Compatibility:	ITU-TS 03
3. Effective Scanning Width:	Max. 208mm
4. Recording Paper Size:	Letter: 216 x 279mm Legal: 216 x 356mm
5. Effective Printing Width:	208mm
6. Transmission Time:	Approx. 30sec/page (3 Normal mode, MS) Approx. 17sec/page (3 Original mode, MS) Approx. 15sec/page (3 Original mode, MS)
7. Fax Redial Times:	Up to 5 times
8. Telephone Redial Times:	Up to 19 times
9. Scanning Details:	Horizontal: 80lines/m Vertical: 3.85lines/mm/Standard mode 7.7lines/mm/Fin or Hi-Fine mode
10. Scanner Type:	Contact Image sensor

Approx. 2,500 sheets of letter size paper can be printed.

10% image area

Specifications	
Main unit specifications	
1. Applicable Lines:	Public switched telephone network
2. Compatibility:	ITU-TS 03
3. Effective Scanning Width:	Max. 208mm
4. Recording Paper Size:	Letter: 216 x 279mm Legal: 216 x 356mm
5. Effective Printing Width:	208mm
6. Transmission Time:	Approx. 30sec/page (3 Normal mode, MS) Approx. 17sec/page (3 Original mode, MS) Approx. 15sec/page (3 Original mode, MS)
7. Fax Redial Times:	Up to 5 times
8. Telephone Redial Times:	Up to 19 times
9. Scanning Details:	Horizontal: 80lines/m Vertical: 3.85lines/mm/Standard mode 7.7lines/mm/Fin or Hi-Fine mode
10. Scanner Type:	Contact Image sensor
11. Printer Type:	Electrophotographic LED array printer
12. Data Compression System:	Modified Huffman (MH), Modified READ (MR)
13. Modem Speed:	9600/7200/4800/2400bps
14. Operating Environment:	10-32.5 C 20-80%RH
15. Dimension (H x W x D):	371 x 148 x 499mm
16. Mass (Weight):	Standby: 12-880g Transmission: 15-950g Ready: 12-880g Copy: 24-500g Hold: 600g
*Transmission Time: Transmission time apply to text data using ITU-TS No. 1 test chart, between the same models at max. run speed and may vary in actual usage.	

Approx. 1,200 sheets of letter size paper can be printed.

15% image area

Specifications	
Main unit specifications	
1. Applicable Lines:	Public switched telephone network
2. Compatibility:	ITU-TS 03
3. Effective Scanning Width:	Max. 208mm
4. Recording Paper Size:	Letter: 216 x 279mm Legal: 216 x 356mm
5. Effective Printing Width:	208mm
6. Transmission Time:	Approx. 30sec/page (3 Normal mode, MS) Approx. 17sec/page (3 Original mode, MS) Approx. 15sec/page (3 Original mode, MS)
7. Fax Redial Times:	Up to 5 times
8. Telephone Redial Times:	Up to 19 times
9. Scanning Details:	Horizontal: 80lines/m Vertical: 3.85lines/mm/Standard mode 7.7lines/mm/Fin or Hi-Fine mode
10. Scanner Type:	Contact Image sensor
11. Printer Type:	Electrophotographic LED array printer
12. Data Compression System:	Modified Huffman (MH), Modified READ (MR)
13. Modem Speed:	9600/7200/4800/2400bps
14. Operating Environment:	10-32.5 C 20-80%RH
15. Dimension (H x W x D):	371 x 148 x 499mm
16. Mass (Weight):	Standby: 12-880g Transmission: 15-950g Ready: 12-880g Copy: 24-500g Hold: 600g
*Transmission Time: Transmission time apply to text data using ITU-TS No. 1 test chart, between the same models at max. run speed and may vary in actual usage.	

Approx. 800 sheets of letter size paper can be printed.

Note:

- The image area changes with the depth, thickness and size of the characters.
- If you turn on the toner save feature, the toner cartridge will last approx. 40% longer.

Drum life

The included drum unit or Model No. KX-FA84 can print approx. 10,000 letter-sized sheets at 20 sheets per print job, and approx. 5,000 letter-sized sheets at 1 sheet per print job regardless of the content of the image area. The actual drum life is determined by various factors, such as temperature, humidity and type of paper, etc.

Note:

- Any details given in these instructions are subject to change without notice.
- The pictures and illustrations in these instructions may vary slightly from the actual product.

10.3 FCC and Other Information

This equipment complies with Part 68 of the FCC rules and the requirements adopted by the ACTA. On the rear of this equipment is a label that contains, among other information, a product identifier in the format US:ACJ-----.

If requested, this number must be provided to the telephone company.

- Registration No(found on the rear of the unit)
- Ringer Equivalence No. (REN)
.....(found on the rear of the unit)

A plug and jack used to connect this equipment to the premises wiring and telephone network must comply with the applicable FCC Part 68 rules and requirements adopted by the ACTA. A compliant telephone cord and modular plug is provided with this product. It is designed to be connected to a compatible modular jack that is also compliant.

The REN is used to determine the number of devices that may be connected to a telephone line. Excessive RENs on a telephone line may result in the devices not ringing in response to an incoming call. In most but not all areas, the sum of RENs should not exceed five (5.0). To be certain of the number of devices that may be connected to a line, as determined by the total RENs, contact the local telephone company. For products approved after July 23, 2001, the REN for this product is part of the product identifier that has the format US:AAAEQ##TXXXX. The digits represented by ## are the REN without a decimal point (e.g., 03 is a REN of 0.3).

If this equipment causes harm to the telephone network, the telephone company will notify you in advance that temporary discontinuance of service may be required. But if advance notice isn't practical, the telephone company will notify the customer as soon as possible. Also, you will be advised of your right to file a complaint with the FCC if you believe it is necessary.

The telephone company may make changes in its facilities, equipment, operations or procedures that could affect the operation of the equipment. If this happens the telephone company will provide advance notice in order for you to make necessary modifications to maintain uninterrupted service.

If trouble is experienced with this equipment, for repair or warranty information, please contact a Factory Servicenter or other Authorized Servicer. If the equipment is causing harm to the telephone network, the telephone company may request that you disconnect the equipment until the problem is resolved.

Connection to party line service is subject to state tariffs. Contact the state public utility commission, public service commission or corporation commission for information.

This equipment is hearing aid compatible as defined by the FCC in 47 CFR Section 68.316.

If your home has specially wired alarm equipment connected to the telephone line, ensure the installation of this equipment does not disable your alarm equipment. If you have questions about what will disable alarm equipment, consult your telephone company or a qualified installer.

WHEN PROGRAMMING EMERGENCY NUMBERS AND(OR) MAKING TEST CALLS TO EMERGENCY NUMBERS:

- 1) Remain on the line and briefly explain to the dispatcher the reason for the call.
- 2) Perform such activities in the off-peak hours, such as early morning or late evenings.

The software contained in this equipment to allow user access to the network must be upgraded to recognize newly established network area codes and exchange codes as they are placed into service. Failure to upgrade the premises systems or peripheral equipment to recognize the new codes as they are established will restrict the customer and the customer's employees from gaining access to the network and to these codes.

CAUTION:

Any changes or modifications not expressly approved by the party responsible for compliance could void the user's authority to operate this device.

NOTE:

This equipment has been tested and found to comply with the limits for a Class B digital device, pursuant to Part 15 of the FCC Rules. These limits are designed to provide reasonable protection against harmful interference in a residential installation. This equipment generates, uses, and can radiate radio frequency energy and, if not installed and used in accordance with the instructions, may cause harmful interference to radio communications. However, there is no guarantee that interference will not occur in a particular installation. If this equipment does cause harmful interference to radio or television reception, which can be determined by turning the equipment off and on, the user is encouraged to try to correct the interference by one or more of the following measures:

- Reorient or relocate the receiving antenna.
- Increase the separation between the equipment and receiver.
- Connect the equipment into an outlet on a circuit different from that to which the receiver is connected.
- Consult the dealer or an experienced radio/TV technician for help.

10.4 Limited Warranty

PANASONIC CONSUMER ELECTRONICS COMPANY,
DIVISION OF MATSUSHITA ELECTRIC
CORPORATION OF AMERICA
One Panasonic Way,
Secaucus, New Jersey 07094

PANASONIC SALES COMPANY,
DIVISION OF MATSUSHITA
ELECTRIC OF PUERTO RICO, INC.,
Ave. 65 de Infantería, Km. 9.5
San Gabriel Industrial Park,
Carolina, Puerto Rico 00985

Panasonic Facsimile Product Limited Warranty

Limited Warranty Coverage

If your product does not work properly because of a defect in materials or workmanship, Panasonic Consumer Electronics Company or Panasonic Sales Company (collectively referred to as “the warrantor”) will, for the length of the period indicated on the chart below, which starts with the date of original purchase (“Limited Warranty period”), at its option either (a) repair your product with new or refurbished parts, or (b) replace it with a new or a refurbished product. The decision to repair or replace will be made by the warrantor.

FAX categories	Parts	Labor
Thermal Transfer Facsimile	6 Months	6 Months
Laser Facsimile	1 (one) Year	1 (one) Year

Batteries, antennas, ink film, toner cartridge, drum unit, and ink cartridge (as may be applicable), and cosmetic parts (cabinet) are not warranted under this Limited Warranty.

During the “Labor” Limited Warranty period there will be no charge for labor. During the “Parts” Limited Warranty period, there will be no charge for parts. You must carry-in or mail-in your product during the Limited Warranty period. This Limited Warranty only applies to products purchased and serviced in the United States or Puerto Rico. This Limited Warranty is extended only to the original purchaser and only covers products purchased as new. A purchase receipt or other proof of the original purchase date is required for Limited Warranty service.

Carry-In or Mail-In Service

For Carry-In or Mail-In Service in the United States call 1-800-HELP-FAX (1-800-435-7329)
For assistance in Puerto Rico call Panasonic Sales Company (787)-750-4300 or fax (787)-768-2910.

Limited Warranty Limits And Exclusions

This Limited Warranty ONLY COVERS failures due to defects in materials or workmanship, and DOES NOT COVER normal wear and tear or cosmetic damage. The Limited Warranty ALSO DOES NOT COVER damages which occurred in shipment, or failures which are caused by products not supplied by the warrantor such as non Panasonic ink film, toner cartridge or drum unit, or failures which result from accidents, misuse, abuse, neglect, mishandling, misapplication, alteration, faulty installation, set-up adjustments, signal reception problems, misadjustment of consumer controls, improper maintenance, power line surge, improper voltage supply, lightning damage, modification, or commercial use (such as in a hotel, office, restaurant, or other business), rental use of the product, service by anyone other than a Factory Servicenter or other Authorized Servicer, or damage that is attributable to acts of God.

THERE ARE NO EXPRESS WARRANTIES EXCEPT AS LISTED UNDER “LIMITED WARRANTY COVERAGE”. THE WARRANTOR IS NOT LIABLE FOR INCIDENTAL OR CONSEQUENTIAL DAMAGES RESULTING FROM THE USE OF THIS PRODUCT, OR ARISING OUT OF ANY BREACH OF THIS LIMITED WARRANTY. (As examples, this excludes damages for lost time, cost of having someone remove or re-install an installed unit if applicable, or travel to and from the servicer. The items listed are not exclusive, but are for illustration only.) **ALL EXPRESS AND IMPLIED WARRANTIES, INCLUDING THE WARRANTY OF MERCHANTABILITY, ARE LIMITED TO THE PERIOD OF THE LIMITED WARRANTY.**

Some states do not allow the exclusion or limitation of incidental or consequential damages, or limitations on how long an implied Limited Warranty lasts, so the exclusions may not apply to you.

This Limited Warranty gives you specific legal rights and you may also have other rights which vary from state to state. If a problem with this product develops during or after the Limited Warranty period, you may contact your dealer or Servicenter. If the problem is not handled to your satisfaction, then write to the warrantor's Consumer Affairs Department at the addresses listed for the warrantor.

PARTS AND SERVICE WHICH ARE NOT COVERED BY THIS LIMITED WARRANTY ARE YOUR RESPONSIBILITY.

For product service

- Call toll-free 1-800-HELP-FAX (1-800-435-7329) for the location of an authorized servicenter.

For out of Limited Warranty technical support

- After the Limited Warranty has expired, please contact our Continued Services Technical Support Line at 1-900-555-PANA (1-900-555-7262) for support on a fee basis.

When you ship the product

- Carefully pack your unit, preferably in the original carton.
- Attach a letter, detailing the symptom or problem, to the outside of the carton.
- Send the unit to an authorized servicenter, prepaid and adequately insured.
- Do not send your unit to the Panasonic Consumer Electronics Company or to any executive or regional sales office. These locations do not repair consumer products.

10.5 Customer Services directory

**To obtain service or technical assistance during the warranty period, please contact: 1-800-HELP-FAX (1-800-435-7329), Monday-Friday 9am-8pm EST.
To obtain support or service after the warranty has expired, please contact: 1-900-555-PANA (1-900-555-7262) for support on a fee basis.
For hearing or speech impaired TTY users, TTY: 1-866-741-6422**

**Web Site: www.panasonic.com
(for customers in the USA or Puerto Rico ONLY)
You can purchase parts, accessories or locate your nearest servicer by
visiting our Web Site.**

**Service in Puerto Rico
Matsushita Electric of Puerto Rico, Inc. Panasonic Sales Company / Factory Servicer:
Ave. 65 de Infantería, Km. 9.5, San Gabriel Industrial Park, Carolina, Puerto Rico 00985
Phone (787) 750-4300 Fax (787) 768-2910**

11.1 Index

- # #00 Quick Setup: 15
- #01 Date and time: 28
- #02 Your logo: 29
- #03 Your fax number: 30
- #04 Sending report: 37, 46
- #06 FAX ring setting: 47
- #12 Remote activation ID: 47
- #13 Dialing mode: 47
- #16 Paper size: 47
- #17 Ringer pattern: 27
- #22 Journal report: 37, 47
- #23 Overseas mode: 47
- #25 Delayed transmission: 47
- #26 Caller ID list: 48
- #31 Distinctive Ring: 42, 48
- #32 Ring pattern: 43, 48
- #37 Auto reduction: 48
- #39 Display contrast: 48
- #41 Fax activation code: 48
- #44 Memory reception alert: 48
- #46 Friendly reception: 48
- #68 ECM selection: 48
- #76 Connecting tone: 48
- #79 Toner save: 49
- #80 Reset advanced features: 49
- A** Accessories
 - A4 Paper guide: 14
 - Paper stacker: 12
 - Paper tray: 12
 Advanced features: 47
 Alert
 - Memory reception (Feature #44): 48
 Answering machine: 21
 Auto reduction (Feature #37): 48
- B** Basic features: 46
 Broadcast transmission: 38
- C** Caller ID
 - Calling back: 33
 - Storing: 34
 Caller ID list (Feature #26): 33, 48
 Caller IQ feature: 64
 Character table: 29
 Cleaning: 61
 Communication messages: 51
 Connecting tone (Feature #76): 48
 Connections: 15
 Copy: 44
 Collation: 44
 Enlarge: 44
 Reduce: 44
- D** Date and time (Feature #01): 28
 Delayed transmission (Feature #25): 47
 Dialing mode (Feature #13): 47
 Direct command: 49
 Display
 - Contrast (Feature #39): 48
 - Error messages: 51
 Distinctive Ring service (Feature #31): 42, 48
 Document size: 37
 Drum life: 69
 Drum unit: 10, 56
- E** ECM selection (Feature #68): 48
 Error messages: 51
 Extension telephone: 40
- F** Fax activation code (Feature #41): 48
 Fax number (Feature #03): 30, 46
 Friendly reception (Feature #46): 48
- H** Help: 27
- J** Jams
 - Document: 60
 - Recording paper: 58
 Journal report (Feature #22): 37, 47
 Junk fax prohibitor: 40
- L** Logo (Feature #02): 29, 46
- N** Navigator directory
 - Making a phone call: 32
 - Selecting characters: 29
 - Sending faxes: 37
 - Storing: 31
- O** One-touch dial
 - Making a phone call: 32
 - Selecting characters: 29
 - Sending faxes: 37
 - Storing: 31
 openLCR service: 64
 Overseas mode (Feature #23): 47
- P** Paper size (Feature #16): 47
 Power failure: 55
 Programming: 46
- Q** Quick scan: 36
 Quick Setup (Feature #00): 15
- R** Receiving
 - Automatically: 40
 - Manually: 39

- Receiving alert (Feature #44): 48
- Recording paper: 13
- Recording paper size: 68
- Redialing: 36, 38
- Remote activation ID (Feature #12): 47
- Reports
 - Broadcast programming: 66
 - Broadcast sending: 39
 - Caller ID: 34, 48
 - Journal: 37, 66
 - Power down: 55
 - Printer test: 66
 - Sending: 37, 46
 - Setup: 66
 - Telephone number: 66
- Reset (Feature #80): 49
- Resolution: 36, 44
- Ringer pattern (Feature #17): 27, 47
- Ring pattern for Distinctive Ring (Feature #32): 43, 48
- Ring setting
 - FAX ONLY (Feature #06): 47

S Sending

- Broadcast: 39
- From memory: 36
- Manually: 36
- Navigator directory: 37
- One-touch dial: 37
- Sending report (Feature #04): 37, 46
- Set default (Feature #80): 49

Storing

- Broadcast: 38
- Navigator directory: 31
- One-touch dial: 31

T Toner cartridge

- Installing: 10
- Replacing: 56
- Toner life: 69
- Toner save (Feature #79): 11, 49

V Volume: 27





Panasonic FAX ADVANTAGE PROGRAM

*Free peace of mind,
direct from Panasonic*

NO EXTRA COST



- **1-year limited warranty¹: parts, labor, and toll-free help line²**
- **Free overnight replacement³ and repair program**

The Panasonic Fax Advantage Consumer Service Program.

Panasonic knows that if your fax machine is not up and running, neither is your business. That's why we created the Panasonic Fax Advantage Program. Included at no extra cost with the purchase of a new and unused Panasonic Fax Machine, the Fax Advantage Program can provide a free replacement unit³ overnight if your original unit is in need of repair.

Here's how it works:

1. If you have a problem with your fax that you purchased new and unused while it is covered by the period of limited warranty¹, call our toll-free help-line at 1-800-HELP-FAX².
2. Talk to one of our technical experts to diagnose your problem over the phone.
3. If repairs are necessary and you are entitled to service under the terms and conditions of the limited warranty⁴, we will send a refurbished replacement unit to you by UPS overnight service delivery.

A second option available under our limited warranty is to mail-in or carry-in your fax to one of our Regional Service centers, where the unit will be repaired and returned to you.

Instructions:

If you choose to receive a replacement unit under the Fax Advantage Program, Panasonic will provide a replacement unit which will be completely refurbished, quality-tested by Panasonic technicians and individually hand-inspected before it is shipped to you. You will keep the replacement unit and send the original unit to us in the replacement unit's box. UPS will pick up the unit at no charge to you, should it be determined that you are entitled to warranty service. A proof-of-purchase must be included with the returned product. Any unit that is replaced by Panasonic and not shipped with proper proof-of-purchase by you will be subject to a minimum \$100.00 charge. The original unit must be properly packaged in the same manner as the replacement unit, utilizing the packing materials provided. Damage due to improper or inadequate packing will be charged to you as an out-of-warranty cost.

If our 1-800-HELP-FAX technicians determine that your unit may be an "out-of-box failure"⁵, we will attempt to provide you with a factory-new replacement unit⁶. You must ship a copy of your receipt with your original unit to verify that you purchased the unit within 10 days prior to your 1-800-HELP-FAX call.

Requirements:

You must give our technicians a valid credit card number (Discover, VISA, Master Card, or American Express/Optima). Product that is not returned to Panasonic by 10 business days after shipment of the replacement product will be charged to your credit card account at Panasonic's Suggested Retail Price (see dealer for details). If your original unit is not eligible for warranty service, your card will be charged for the non-warranty repair of the unit at Panasonic's current rate for parts and labor and for any shipping charges associated with this program. If you do not wish to pay out-of-warranty repair costs, you will be responsible for returning the replacement unit to Panasonic and for paying all shipping charges associated with this program including the overnight delivery of the replacement product to you, shipment of the problem unit to Panasonic, shipment of the replacement unit back to Panasonic and the return of your original unit back to you. Credit status will be verified prior to sending the replacement product.

1. See dealer for limited warranty details.
2. After the fax advantage program, contact our Continued Services Technical Support Line at 1-900-555-PANA (1-900-555-7262), for fee based technical support.
3. Replacement unit is refurbished.
4. Replacement program is only available in the 50 United States and is subject to termination at any time without advance notice.
5. "Out-of-box failure" is an inoperable unit that was purchased no more than 10 days prior to your 1-800-HELP-FAX call, and would otherwise qualify for warranty service under the terms and conditions of the limited warranty.
6. Panasonic reserves the right to send a refurbished unit.

**Panasonic Consumer Electronics
Company, Division of Matsushita
Electric Corporation of America**

One Panasonic Way,
Secaucus, New Jersey 07094

**Panasonic Sales Company,
Division of Matsushita Electric of
Puerto Rico, Inc.**

Ave. 65 de Infantería, Km. 9.5
San Gabriel Industrial Park, Carolina,
Puerto Rico 00985

Free Manuals Download Website

<http://myh66.com>

<http://usermanuals.us>

<http://www.somanuals.com>

<http://www.4manuals.cc>

<http://www.manual-lib.com>

<http://www.404manual.com>

<http://www.luxmanual.com>

<http://aubethermostatmanual.com>

Golf course search by state

<http://golfingnear.com>

Email search by domain

<http://emailbydomain.com>

Auto manuals search

<http://auto.somanuals.com>

TV manuals search

<http://tv.somanuals.com>