

Panasonic

Flat-Bed Multi-Function Laser Fax

Operating Instructions

Model No. **KX-FLB756E**

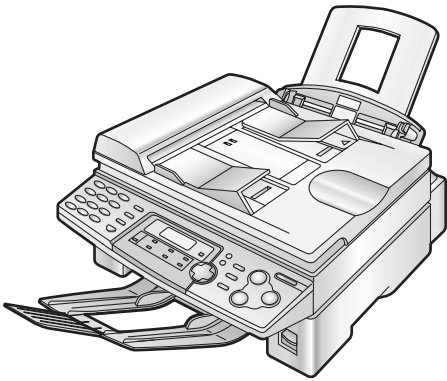

Please read these Operating Instructions before using the unit and save for future reference.

This model is designed to be used in the United Kingdom and Ireland.

IMPORTANT

Panasonic

WARRANTY REGISTRATION

**PLEASE FAX BACK TO REGISTER FOR
YOUR 12 MONTHS WARRANTY**

FAX BACK NUMBER 08700 600001

Thank you for purchasing your Panasonic facsimile. By filling in the section below, this will ensure the following:

- Should you ever require a service call under warranty, your call will be dealt with quickly and efficiently.
- If you have any problems, please call our customer helpline on 08701 580560 for UK. For the Republic of Ireland, please call 01 6130082
- Please have your serial number and D. O. P. ready.

Simply, follow these instructions:

1. Please fill in the section below in block capitals and in ink.

Your name

Company name (if applicable)

Your address

Your postcode

Telephone no. Fax no.

Model no.

Serial no. Date of purchase Day Month Year

2. Please fax this completed form to 08700 600001

3. For information on Warranty Upgrades please contact us on 08701 580560 or, for the Republic of Ireland, please call 01 6130082

TERMS AND CONDITIONS

1. This machine is supplied with a one year swap out warranty. Please retain your Proof of Purchase and Packaging in the unlikely event that your machine should require attention. For further information, please contact us on 08701 580560 for UK, 01 6130082 for the Republic of Ireland, or visit our web site at www.panasonic.co.uk
2. This warranty is in addition to and does not in any way affect any statutory or other right of consumer purchasers. This warranty relates only to product used within Mainland Great Britain, please refer to your dealer warranty information relating to use elsewhere within the United Kingdom.
3. This product is designed for use only on the United Kingdom and Ireland's Public Switched Telephone Network and should be used only for normal purposes and in accordance with standard operating instructions.
4. You should complete the registration form overleaf and fax it to us with 7 days of purchase; failure to do so may result in delays in providing warranty service.
5. This warranty covers breakdowns due to design or manufacturing faults; it does not apply to damage, however caused, wear or tear, neglect, incorrect adjustment or repair, or to any items of limited natural life.
6. This warranty does not cover consumables, i.e. ink films, film refills, ink cartridges, toner cartridges, drum units, paper and paper loads or any optional accessories which may have been purchased either at the same time, as or subsequent to, the main unit. Such accessories should be returned to the point of purchase if found to be faulty.
7. In the event of a failure, please take the following action;
 - a. Refer to the "Help" section of your instruction manual in order to identify and possibly correct the problem:
 - b. If the problem is not resolved after referring to the user guide, please contact our customer helpline on 08701 580560 for UK or 01 6130082 for the Republic of Ireland
8. In the event the helpline cannot resolve the problem, a like for like exchange fax will be despatched overnight (if the call is received before 4pm) or, by a mutually convenient arrangement. The helpline operator will give you specific instructions on how the exchange will be executed. Failure to comply with these instructions may result in delay and cost to you.
9. The exchange fax will be delivered in a customised case by courier. It is the customer's responsibility to promptly remove the exchange fax and insert the faulty fax in the case provided for collection, to enable the courier to return it to Panasonic.
10. The exchange fax is to be regarded as a like for like exchange under warranty and the balance of the warranty period will transfer to the exchange unit.
The liability of Panasonic under the terms of this warranty is limited to the exchange of the fax, or the repair and return of the original fax (subject to any additional charges).
11. Where the original fax is found to be faulty as a result of unauthorised repairs or modifications or damage either by accident, misuse or improper installation then Panasonic reserves the right to charge the customer the sum of £50.00 plus VAT, as a contribution towards repair costs.
12. This warranty applies to the original purchaser only and is not transferable.
13. The warranty period applicable to this product shall be 12 months from the date of purchase.

Fax to 08700 600001

Thank you for purchasing a Panasonic facsimile.

Things you should keep a record of

┌───┐
│ Attach your sales receipt here │
└───┘

For your future reference

Date of purchase _____	Serial number _____ (found on the rear of the unit)
Dealer's name and address _____	
Dealer's telephone number _____	

Caution:

- Do not rub or use an eraser on the printed side of recording paper, as the print may smear.
- In the event of problems, you should contact your equipment supplier in the first instance.
- This equipment is designed for use on the UK and Republic of Ireland analogue telephone network.

Warning:

If any other device is connected on the same line, this unit may disturb the network condition of the device.

Declaration of Conformity:

We, Panasonic Communications Co., Ltd., declare that this equipment is in compliance with the essential requirements and other relevant provisions of Directive 1999/5/EC.

If you want to get a copy of the original Declaration of Conformity of our products which relates to the R&TTE, please contact to our web address:

<http://doc.panasonic-tc.de>

Trademarks:

- Microsoft, Windows and Windows NT are either registered trademarks or trademarks of Microsoft Corporation in the United States and/or other countries.
- Pentium is a registered trademark or trademark of Intel Corporation in the United States and/or other countries.
- All other trademarks identified herein are the property of their respective owners.

Copyright:

This manual is copyrighted by Panasonic Communications Co., Ltd. (PCC) and its licensee. Under the copyright laws, this manual may not be reproduced in any form, in whole or part, without the prior written consent of PCC and its licensee.

© Panasonic Communications Co., Ltd. 2003

Important safety instructions

When using this unit, basic safety precautions should always be followed to reduce the risk of fire, electric shock, or personal injury.

1. Read and understand all instructions.
2. Follow all warnings and instructions marked on this unit.
3. Unplug this unit from power outlets before cleaning. Do not use liquid or aerosol cleaners. Use a damp cloth for cleaning.
4. Do not use this unit near water, for example near a bathtub, wash bowl, kitchen sink, or the like.
5. Place the unit securely on a stable surface. Serious damage and/or injury may result if the unit falls.
6. Do not cover slots and openings on the unit. They are provided for ventilation and protection against overheating. Never place the unit near radiators, or in a place where proper ventilation is not provided.
7. Use only the power source marked on the unit. If you are not sure of the type of power supplied to your home, consult your dealer or local power company.
8. For safety purposes this unit is equipped with a grounded plug. If you do not have this type of outlet, please have one installed. Do not defeat this safety feature by tampering with the plug.
9. Do not place objects on the mains lead. Install the unit where no one can step or trip on the mains lead.
10. Do not overload wall outlets and extension cords. This can result in the risk of fire or electric shock.
11. Never push any objects through slots in this unit. This may result in the risk of fire or electric shock. Never spill any liquid on the unit.
12. To reduce the risk of electric shock, do not disassemble this unit. Take the unit to an authorised service centre when service is required. Opening or removing covers may expose you to dangerous voltages or other risks. Incorrect reassembly can cause electric shock when the unit is subsequently used.
13. Unplug this unit from the wall outlet and refer servicing to an authorised service centre when the following conditions occur:
 - A. When the power supply cord or plug is damaged or frayed.
 - B. If liquid has been spilled into the unit.
 - C. If the unit has been exposed to rain or water.
 - D. If the unit does not work normally by following the operating instructions. Adjust only controls covered by the operating instructions. Improper adjustment may require extensive work by an authorised service centre.
 - E. If the unit has been dropped or physically damaged.
 - F. If the unit exhibits a distinct change in performance.
14. During thunderstorms, avoid using telephones except cordless types. There may be a remote risk of an electric shock from lightning.
15. Do not use this unit to report a gas leak, when in the vicinity of the leak.

SAVE THESE INSTRUCTIONS

Safety instructions

CAUTION:

Laser radiation

- The printer of this unit utilises a laser. Use of controls or adjustments or performance of procedures other than those specified herein may result in hazardous radiation exposure.

CLASS 1 LASER PRODUCT
KLASSE 1 LASER PRODUKT
CLASSE 1 LASER PRODUIT
CLASE 1 LÁSER PRODUCTO

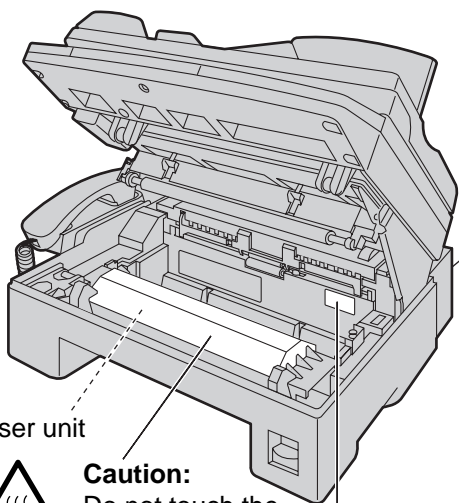

Fuser unit



Caution:

Do not touch the bottom of this cover. It is very hot.

DANGER: Invisible laser radiation when open and interlock defeated. AVOID DIRECT EXPOSURE TO BEAM.

ATTENTION: Rayonnement laser invisible dangereux en cas d'ouverture et lorsque la sécurité est neutralisée. EXPOSITION DANGEREUSE AU FAISCEAU.

VORSICHT: Unsichtbare Laserstrahlung, wenn Abdeckung geöffnet und Sicherheitsverriegelung überbrückt. NICHT DEM STRAHL AUSSETZEN.

PELIGRO: Cuando se abre y se invalida el bloqueo, se producen radiaciones invisibles de láser. EVÍTESE LA EXPOSICIÓN A TALES RAYOS.



Fuser unit

- The fuser unit is inside of the unit and gets hot. Do not touch it when removing the jammed paper or cleaning the lower glass.

Toner cartridge

- Be careful of the following when you handle the toner cartridge:
 - Do not leave the toner cartridge out of the protection bag for a long time. It will decrease the toner life.
 - If you ingest any toner, drink several glasses of water to dilute your stomach contents, and seek immediate medical treatment.
 - If any toner comes into contact with your eyes, flush them thoroughly with water, and seek medical treatment.
 - If any toner comes into contact with your skin, wash the area thoroughly with soap and water.

Drum unit

- Read the instructions on pages 16 and 17 before you begin installation of the drum unit. After you have read them, open the drum unit protection bag. The drum unit contains a photosensitive drum. Exposing it to light may damage the drum. Once you have opened the protection bag:
 - Do not expose the drum unit to light for more than 5 minutes.
 - Do not touch or scratch the green drum surface.
 - Do not place the drum unit near dust or dirt, or in a high humidity area.
 - Do not expose the drum unit to direct sunlight.

Static electricity

- To prevent static electricity damage to the interface connectors (parallel and USB), ADF socket or other electrical components inside the unit, touch a grounded metal surface, such as the metal part under the parallel interface connector before touching the components.

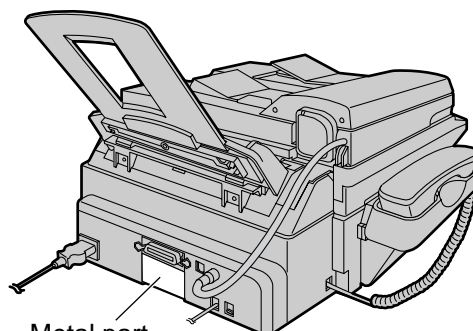

Metal part

INSTALLATION:

- After moving the unit from cold areas to warmer areas, let the unit adjust to the warmer temperature and do not connect the unit for about 30 minutes. If the unit is connected too soon after a sudden climate change, condensation may form inside the unit causing malfunction.
- Never install telephone wiring during a lightning storm.
- Never install telephone sockets in wet locations unless the socket is specifically designed for wet locations.
- Never touch uninsulated telephone wires or terminals unless the telephone line has been disconnected at the network interface.
- Use caution when installing or modifying telephone lines.

WARNING:

- To prevent the risk of fire or electrical shock, do not expose this product to rain or any type of moisture.

OTHER INFORMATION:

- Keep the unit away from electrical noise generating devices, such as fluorescent lamps and motors.
- The unit should be kept free from dust, high temperature and vibration.
- The unit should not be exposed to direct sunlight.
- Do not place heavy objects on top of this unit.
- Do not touch the plug with wet hands.

Important Information

The connection to the telecommunication systems must not be hard wired and must be unplugged before the earth is disconnected.

Method of connection

This apparatus is connected to the exchange line or PABX/PMBX extension by the new standard British Telecom plug and socket. Arrangements for provision of this type of termination can be made through the nearest British Telecom Sales Office.

This apparatus may be connected to the following types of installation.

- a) For connection to the public switched telephone network (PSTN) and compatible (Private Branch Exchange), which use DTMF signalling. (Please consult your supplier for an up to date list of compatible PBX's.)
- b) The apparatus can be used on extension sockets connected to a direct exchange line (D.E.L.).
- c) This apparatus is suitable for connection to the telecommunication system directly or via compatible private branch exchange as an extension. The supplier of the apparatus should be consulted for an up to date list of PBX's with which the apparatus is compatible.

It cannot be guaranteed that the apparatus will operate under all possible conditions of connection to compatible PBX's.

- This apparatus is suitable for connection to a PBX with or without initial proceed indication.
- This apparatus is suitable for connection to a PBX with or without secondary proceed indication.

Any cases of difficulty should be referred in the first instance to the supplier of the apparatus.

- d) The apparatus must not be connected in the following manner:
 - As an extension to a pay phone
 - As a party line with shared service

NOTES:

- If you experience any problems with the normal use of your apparatus, you should unplug it from the telephone outlet and connect a known working telephone in its place. If the known working telephone still gives problems, then please contact the customer service department of your PSTN operator (e.g. BT etc.). If it operates properly, then the problems are likely to be a fault in your apparatus. In this case, consult your supplier for advice.
- Your PSTN operator may charge you if they attend a service call that is not due to apparatus supplied by them.

Fitting a plug to the mains lead

This appliance is supplied with a moulded three pin mains plug for your safety and convenience.

A 13 amp fuse is fitted in this plug.

Should the fuse need to be replaced please ensure that the replacement fuse has a rating of 13 amps and that it is approved by ASTA or BSI to BS1362.

Check for ASTA mark  or the BSI

mark  on the body of the fuse.

If the plug contains a removable fuse cover you must ensure that it is refitted when the fuse is replaced.

If you lose the fuse cover the plug must not be used until a replacement cover is obtained.

A replacement fuse cover can be purchased from your local Panasonic dealer.

IF THE FITTED MOULDED PLUG IS UNSUITABLE FOR THE SOCKET OUTLET IN YOUR HOME THEN THE FUSE SHOULD BE REMOVED AND THE PLUG CUT OFF AND DISPOSED OF SAFELY. THERE IS A DANGER OF SEVERE ELECTRICAL SHOCK IF THE CUT OFF PLUG IS INSERTED INTO ANY 13 AMP SOCKET.

If a new plug is to be fitted please observe the wiring code as shown below.

If in any doubt please consult a qualified electrician.

WARNING: THIS APPLIANCE MUST BE EARTHED.

IMPORTANT:

The wires in this mains lead are coloured in accordance with the following code:

Green-and-Yellow:	Earth
Blue:	Neutral
Brown:	Live

As the colours of the wire in the mains lead of this appliance may not correspond with the coloured markings identifying the terminals in your plug, proceed as follows.

The wire which is coloured GREEN-AND-YELLOW must be connected to the terminal in the plug which is marked with the letter E or by the Earth symbol \perp or coloured GREEN or GREEN-AND-YELLOW.

The wire which is coloured BLUE must be connected to the terminal in the plug which is marked with the letter N or coloured BLACK.

The wire which is coloured BROWN must be connected to the terminal in the plug which is marked with letter L or coloured RED.

How to replace the fuse: Open the fuse compartment with a screwdriver and replace the fuse (and fuse cover).

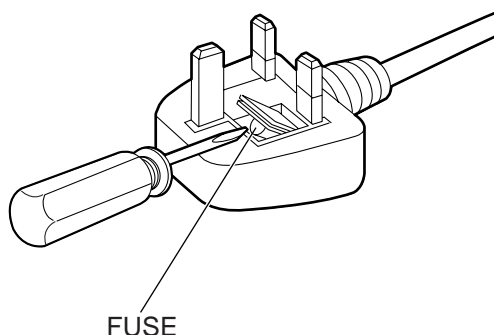
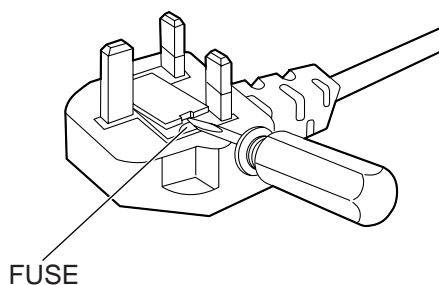

Table of Contents

Initial Preparation

Accessories	Included accessories	10
	Accessory information	11
Help Button	Help function	12
Finding the Controls	Overview	13
	Location	14
Setup	Connecting the document cover	15
	Unlocking the shipping lock	15
	Toner cartridge and drum unit	16
	Paper stacker and paper tray	18
	Recording paper	19
	Connections	20
	Date and time, your logo and facsimile telephone number	21
Volume	Adjusting volume	25

Telephone

Recall Feature	R button (to use the recall feature)	25
Automatic Dialling	Storing names and telephone numbers into one-touch dial	26
	Storing names and telephone numbers into navigator directory	27
	Editing a stored entry	28
	Erasing a stored entry	28
	Making a phone call using one-touch dial and navigator directory	29
Caller ID	Caller ID service from your phone company	30
	Viewing and calling back using caller information	31
	Erasing caller information	32
	Storing caller information into one-touch dial and navigator directory	33

Fax

Sending Faxes	Sending a fax manually	34
	Documents you can send	36
	Sending a fax using one-touch dial and navigator directory	37
	Broadcast transmission	38
Receiving Faxes	Setting the unit to receive faxes	42
	TEL mode (answering all calls manually)	44
	FAX ONLY mode (all calls are received as faxes)	45
	Using the unit with an answering machine	46
	Extension telephone	47

Copy

Copying	Making a copy	48
----------------	-------------------------	----

Multi-Function Station software

Setup (PC)	Connecting to a computer	50
	Installing Multi-Function Station software	51
	Activating Multi-Function Station software	52
Printing (PC)	Using the fax machine as a printer	53
Scanning (PC)	Using the fax machine as a scanner	56
Remote Control (PC)	Operating the fax machine from your computer	57
PC Fax	Fax sending/receiving using Multi-Function Station software	58

Programmable Features

Features Summary	Programming	60
	Basic features	61
	Advanced features	63

Help





Error Messages	Reports	66
	Display	67
Operations	When a function does not work, check here before requesting help	69
	If a power failure occurs	72
Replacement	Replacing the toner cartridge and the drum unit	73
Jams	Recording paper jam	75
	Document jams - sending	77
Cleaning	White plate and glasses	77
	Document feeder rollers	79

General Information

Printed Reports	Reference lists and reports	80
Specifications	Technical data about this product	81
Guarantee	Condition of guarantee	83
Index	Program index	84
	Index	84

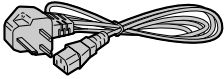
Accessories

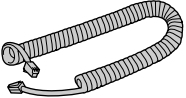
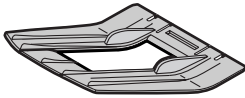
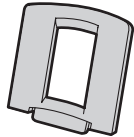
Included accessories

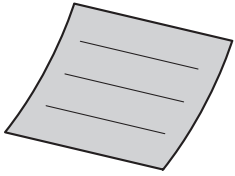
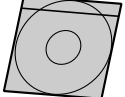
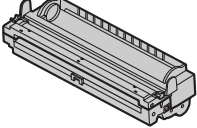
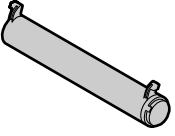
<p>Mains lead.....1</p>  <p>Order No. PFJA03A008Z</p>	<p>Telephone line cord.....1</p>  <p>Order No. PQJA87S (for UK)</p>	<p>Handset.....1</p>  <p>Order No. PFJXE1005Z</p>
<p>Handset cord.....1</p>  <p>Order No. PQJA10126Z</p>	<p>Paper stacker1</p>  <p>Order No. PFZX1FL501M</p>	<p>Paper tray.....1</p>  <p>Order No. PFZXFLB751M</p>
<p>Operating instructions1</p>  <p>Order No. PFQX1822Z</p>	<p>Quick Start Sheet.....1</p>  <p>Order No. PFQW1931Z</p>	<p>CD-ROM.....1</p>  <p>Order No. PFJKFLB756Z</p>
<p>Drum unit.....1</p>  <p>Model No. KX-FA78X</p>	<p>Toner cartridge.....1 (complementary starter toner cartridge)</p>  <p>This cartridge can print approx. 800 sheets of A4 size paper with a 5% image area. Refer to image area on page 82. Please purchase a Panasonic replacement toner cartridge Model No. KX-FA76X/KX-FA79X for continuous use of your unit. See next page for accessory information.</p>	

- If any items are missing or damaged, check with the place of purchase.
- The order numbers listed above are subject to change without notice.
- Save the original carton and packing materials for future shipping and transportation of the unit.

Accessory information

Sales and Support Information

Customer Care Centre

- For UK customers: 08701 580560
- For Republic of Ireland customers: 01 289 8333
- Visit our website for product information
- E-mail: customer.care@panasonic.co.uk

Direct Sales at Panasonic UK

- Order accessory and consumable items for your product with ease and confidence by phoning our Customer Care Centre Monday - Friday 9:00am - 5:30pm (Excluding public holidays).
- Or go on line through our Internet Accessory ordering application at www.panasonic.co.uk
- Most major credit and debit cards accepted.
- All enquires transactions and distribution facilities are provided directly by Panasonic UK Ltd.
- It couldn't be simpler!
- Also available through our Internet is direct shopping for a wide range of finished products, take a browse on our website for further details.

Model No.	Item	Usage	Specifications
KX-FA76X	Toner cartridge (1 pack)	For replacement, see page 73.	See page 82.
KX-FA79X*	Toner cartridge (2 packs)	For replacement, see page 73.	See page 82.
KX-FA78X	Drum unit	For replacement, see page 73.	See page 82.

* KX-FA79X contains 2 packs of KX-FA76X, which is increased by 20% of quantity each, compared to the single pack.

Extension telephone adaptor for UK

When using the unit with an external answering machine (p. 46), please purchase an extension telephone adaptor by contacting one of the following:

- www.panasonic.co.uk
- Panasonic Customer Care Centre on Telephone number 08701 580560
- local Panasonic authorised dealer

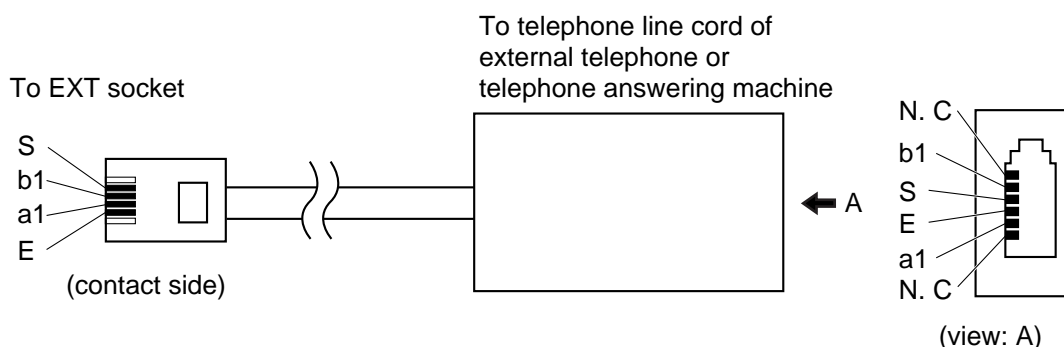

a1, b1: Line
S : Shunt
E : Earth Recall (This function is not provided on this fax machine.)

Help Button

Help function

You can print a quick reference for assistance as follows.

1 Press **HELP**.

Display:

PRESS NAVI. [◀ ▶] & SET

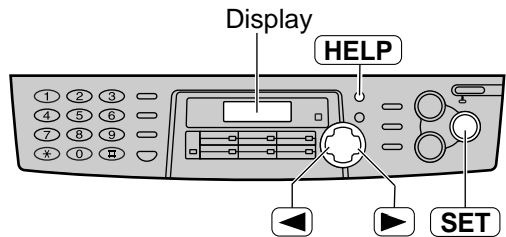

2 Press **◀** or **▶** until the desired item is displayed.

1. How to set the date, time, your logo and fax number.

QUICK SET UP PRESS SET

2. How to program the features.

FEATURE LIST PRESS SET

3. How to store names in the directory and how to dial them.

DIRECTORY PRESS SET

4. Help with problems receiving faxes.

FAX RECEIVING PRESS SET

5. How to use the copier function.

COPIER PRESS SET

6. List of available reports.

REPORTS PRESS SET

7. How to use the Caller ID service.

CALLER ID PRESS SET

3 Press **SET**.

PRINTING

Overview

Front view

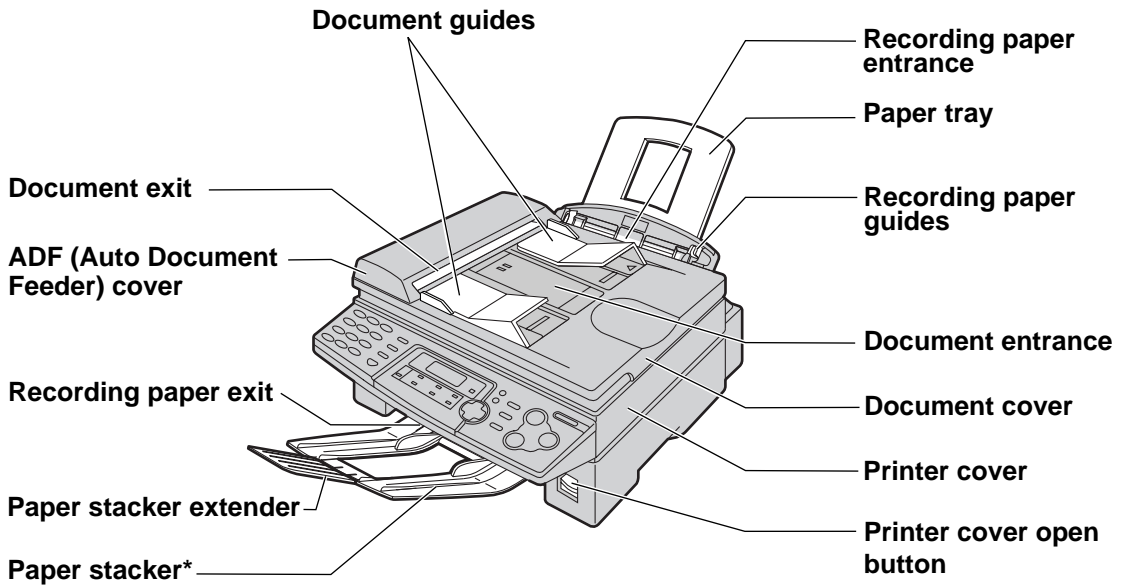

* The paper stacker may not be shown in all illustrations.

Rear view

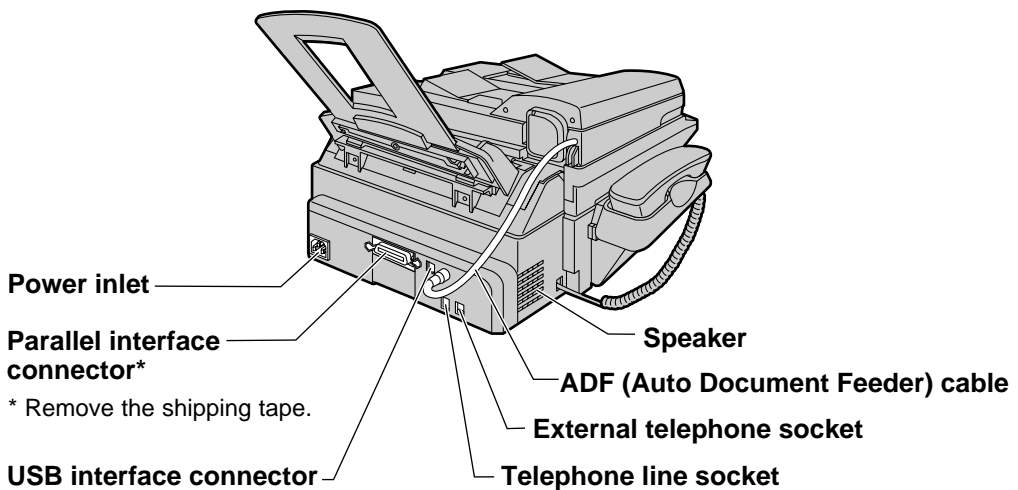

* Remove the shipping tape.

Finding the Controls

Location

-
- To redial the last number dialled.
 - To insert a pause during dialling.
 - To mute your voice to the other party during a conversation. Press this button again to resume the conversation.
 - To turn on/off AUTO ANSWER (p. 42, 43).
 - To initiate or exit programming.
 - To print a quick reference (p. 12).
 - To use caller ID service (p. 31, 33).
 - To confirm a stored telephone number (p. 31).
 - To make a collated copy (p. 49).
 - To initiate copying (p. 48).
 - To access special telephone services such as Call Waiting or for transferring extension calls (p. 25).
 - To dial without lifting the handset.
 - To select stations 7–12 for one-touch dial (p. 26, 29, 37).
 - To use one-touch dial (p. 26, 29, 37).
 - To transmit to multiple entries (p. 38, 41).
 - To adjust volume (p. 25).
 - To search for a stored name (p. 29, 37).
 - To select the features or feature settings during programming (p. 60).
 - To navigate to the next operation.
 - To scan the document into memory (p. 34, 35, 49).
 - To use the fax machine as a scanner when connecting to a computer (p. 56).
 - To select a resolution (p. 34, 48).
 - To stop an operation or cancel programming.
 - To initiate fax transmission or reception.
 - To store a setting during programming.

Connecting the document cover

- 1 Gently insert the two tabs on the document cover into the slots on the unit (1), then close the document cover (2).

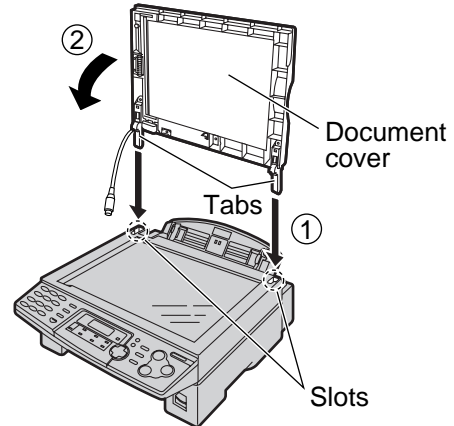

- 2 Connect the ADF cable to the socket on the back of the unit.
 - The arrow (⇨) on the ADF cable must be facing down.

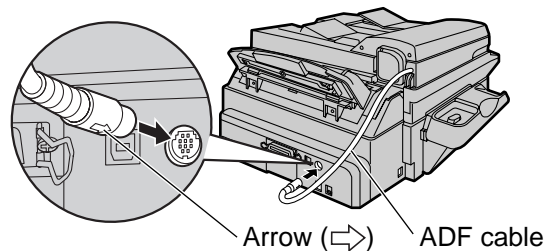

Unlocking the shipping lock

The shipping lock is used to avoid damaging the scanner when it is being transported. Before using the unit, unlock the shipping lock.

- 1 Press down the printer cover open button then open the printer cover.

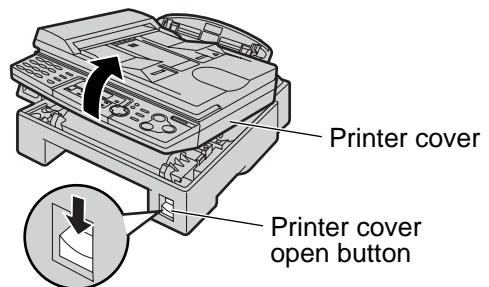

- 2 Slide down the shipping lock.
 - The label for unlocking the shipping lock is attached to the unit. Remove and read it.

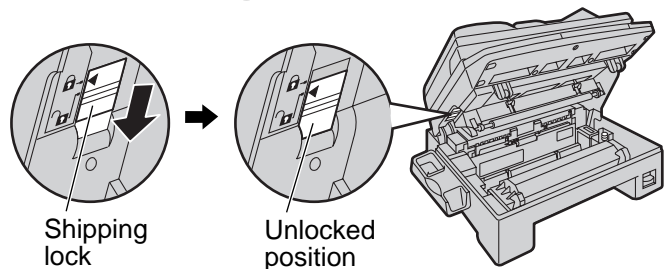

- 3 Close the printer cover by pushing down on both sides until locked.

Caution:

- Whenever transporting the unit, be sure to slide up the shipping lock to lock it.

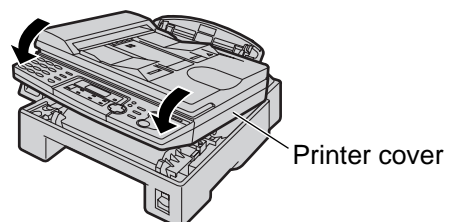

Setup

Toner cartridge and drum unit

Caution:

- Read the instructions below before you begin installation. After you have read them, open the drum unit protection bag. The drum unit contains a photosensitive drum. Exposing it to light may damage the drum. Once you have opened the protection bag:
 - Do not expose the drum unit to light for more than 5 minutes.
 - Do not touch or scratch the green drum surface.
 - Do not place the drum unit near dust or dirt, or in a high humidity area.
 - Do not expose the drum unit to direct sunlight.
- Do not leave the toner cartridge out of the protection bag for a long time. It will decrease the toner life.

- 1** Before opening the protection bag of the new toner cartridge, shake it vertically more than 5 times.



- 2** Remove the toner cartridge and drum unit from the protection bags. Peel off the seal from the toner cartridge (①). Remove the protection bar from the drum unit (②).

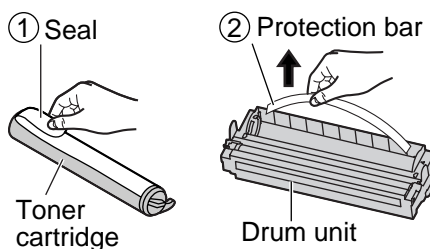

- 3** With "Panasonic" face up on the toner cartridge, match the red arrows on the cartridge and the drum unit.

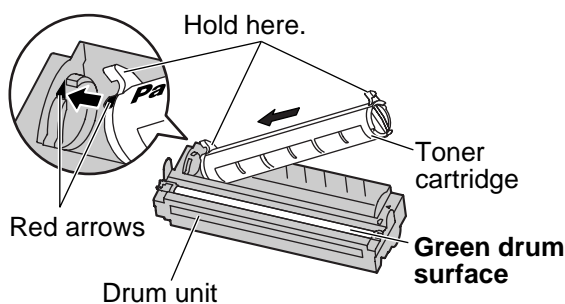

- 4** Slide the tab on the toner cartridge into the slot of the drum unit.

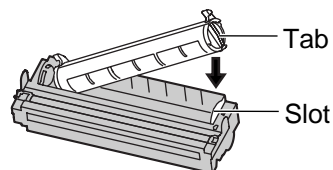

- 5a** Firmly press down on the right side of the toner cartridge to snap into position and...

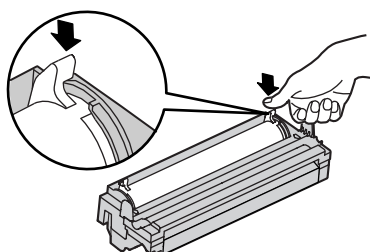

5b turn the two levers on the toner cartridge with firm pressure.

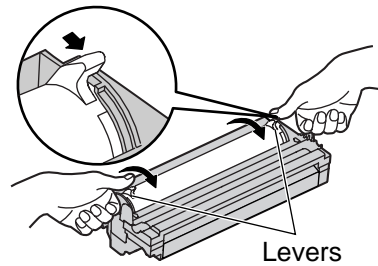

6 The toner cartridge is installed correctly when the triangles match.

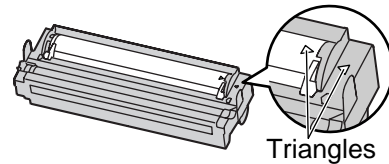

7 Press down the printer cover open button then open the printer cover.

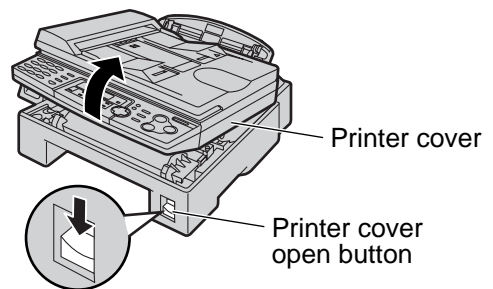

8 Install the drum and toner unit by holding the tabs.
 ● If the lower glass is dirty, clean it with a soft and dry cloth.

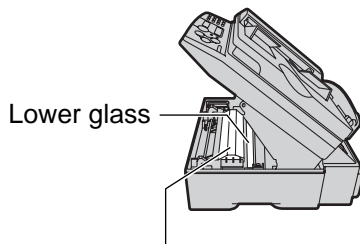

Caution:
Do not touch the bottom of this cover when cleaning the lower glass. It is very hot.

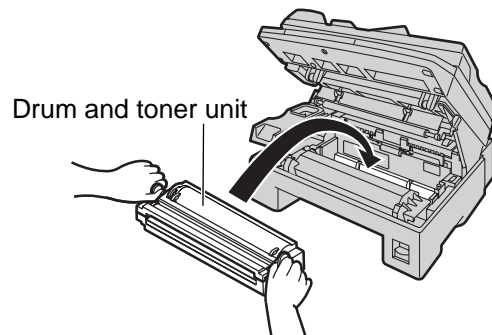

9 Close the printer cover by pushing down on both sides until locked.

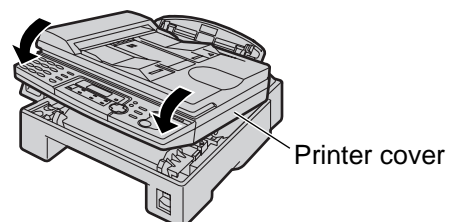

Toner save feature

- If you want to save on toner consumption, set the toner save setting to on (feature #79 on page 65). The toner cartridge will last approx. 40% longer. This feature may lower the print quality.

Setup

Paper stacker and paper tray

Paper stacker

Line up the slots in the paper stacker with the pegs on the bottom of the unit, then slide until locked.

Open the paper stacker extender when using legal size paper.

- The paper stacker can hold up to approx. 100 sheets of printed paper. Remove the printed paper before the paper stacker becomes full.

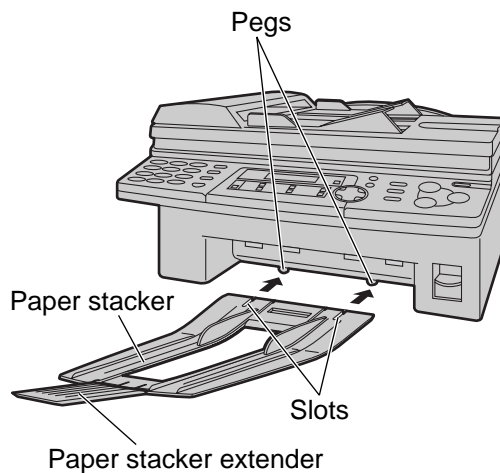

Paper tray

Insert the paper tray into the slot on the back of the unit.

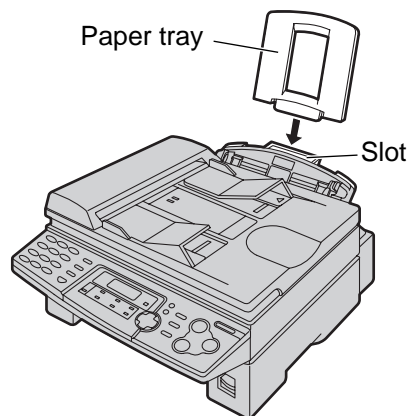

Note for installation:

- Do not place the unit in an area where the paper tray may be obstructed (i.e. by a wall etc.).
- Recording paper will be ejected from the front of the unit. Do not place anything in front of the unit.

Recording paper

A4, letter or legal size recording paper can be used for fax messages. The unit can hold up to 150 sheets of 60 g/m² to 80 g/m² paper or 120 sheets of 90 g/m² paper. See the note for paper specifications on page 82.

- The unit is set for A4 size paper by default. If you want to use letter or legal size paper, change the setting (feature #16 on page 62).

- 1 Pinch the right side of the recording paper guides, then slide it open to its full width.

Right side of the recording paper guides

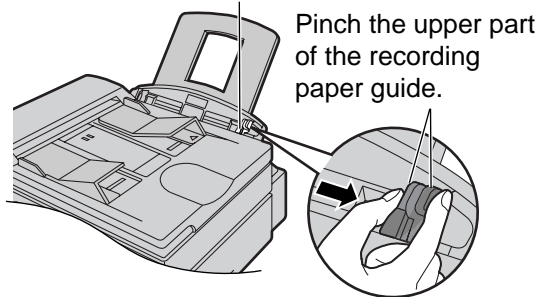

- 2 Fan the stack of paper to prevent a paper jam.

- 3 Insert the paper into the recording paper entrance.
 - The paper should not be over the tab.
 - If the paper is not inserted correctly, readjust the paper, or the paper may jam.

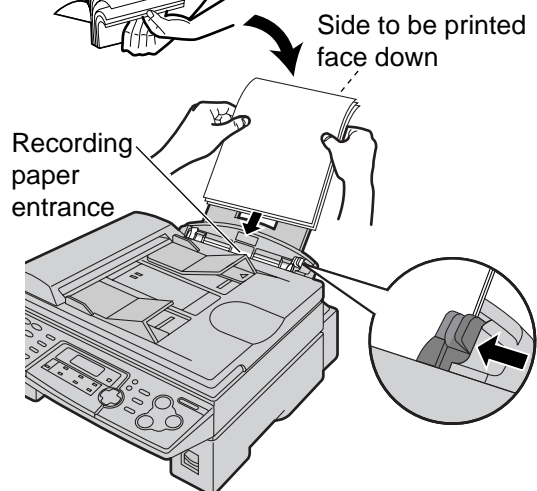
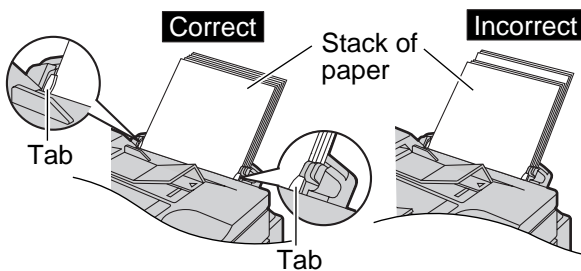

- 4 Adjust the width of the guides to the size of the recording paper by sliding the right side of the guides.

Adding paper

1. Remove all of the paper.
2. Add paper to the stack of paper you removed and straighten.
3. Follow steps 1 to 4 above.

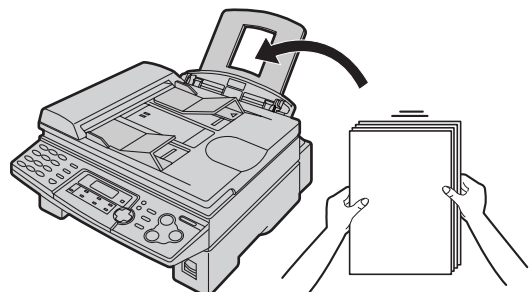

Setup

Connections

- 1 Connect the handset cord.
 - The plug on the longer, uncoiled end of the handset cord should be connected to the unit.
- 2 Connect the telephone line cord.
- 3 Connect the mains lead. (Switch on AC mains outlet.)
 - When the power is turned on for the first time, the unit will print some basic information.

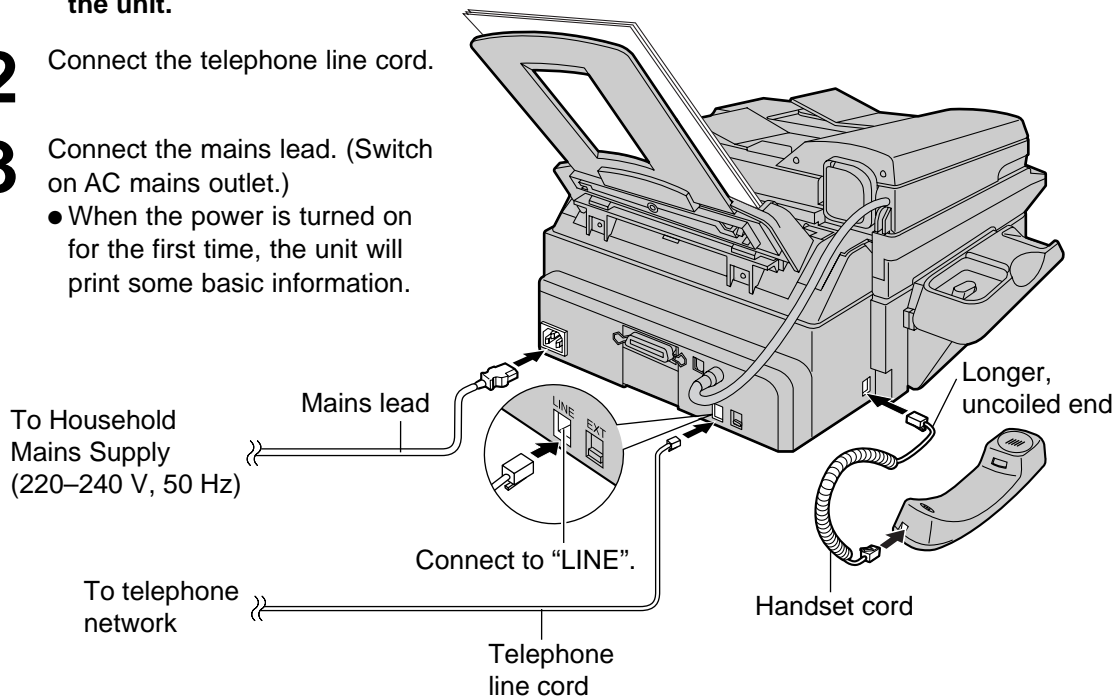

Caution:

- Never install telephone wiring during a lightning storm.
- When you operate this product, the power outlet should be near the product and easily accessible.
- Be sure to use the telephone line cord included in this unit.
- Do not extend the telephone line cord.

Note:

- You can connect an answering machine or extension telephone to the external telephone socket ("EXT") on this unit (p. 46, 47).
- When the power is turned on and the display shows the following, unlock the shipping lock (p. 15).

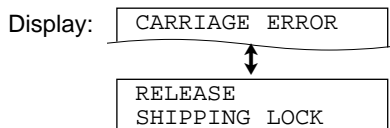

To use the fax machine with a computer on the same line

- We recommend you use separate wall sockets for the fax machine and the computer.
- Set the fax machine to TEL mode (p. 44).
- The device which has the shortest ring setting will answer the call first.
- If the computer provides a port for a telephone line, connect the fax machine to this port on the computer.

Date and time, your logo and facsimile telephone number

You should program the date and time, your logo and facsimile telephone number. This information will be printed on each page transmitted from your unit.

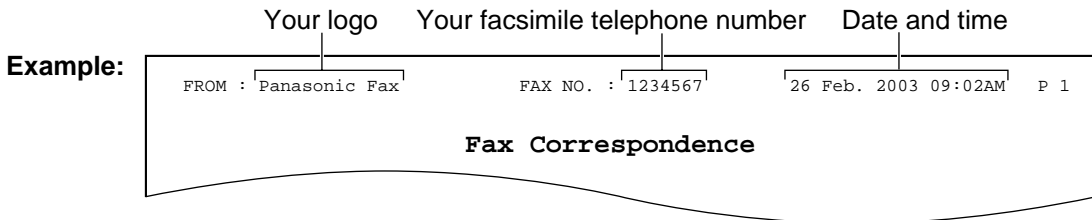

Setting the date and time

1 Press **MENU**.

Display: SYSTEM SET UP
PRESS NAVI. [◀ ▶]

2 Press **◀** or **▶** until the following is displayed.

SET DATE & TIME
PRESS SET

3 Press **SET**.

Cursor
Example: D:01/M:01/Y:03
TIME: 12:00AM

4 Enter the correct day/month/year by selecting 2 digits for each, using the dial keypad.

Example: 10 August, 2003

Press **1 0 0 8 0 3**.

D:10/M:08/Y:03
TIME: 12:00AM

5 Enter the correct hour/minute by selecting 2 digits for each, using the dial keypad.

Press ***** to select "AM" or "PM".

Example: 3:15PM

1. Press **0 3 1 5**.

D:10/M:08/Y:03
TIME: 03:15AM

2. Press ***** until "PM" is displayed.

D:10/M:08/Y:03
TIME: 03:15PM

6 Press **SET**.
• The next feature will be displayed.

YOUR LOGO
PRESS SET

7 Press **MENU** to exit the program.

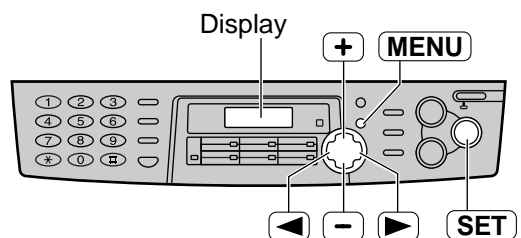

Note:

- You can enter the number by pressing **+** or **-** in steps 4 and 5. In this case, press **▶** to move the cursor.
- The accuracy of the clock is approximately ± 60 seconds a month.

To correct a mistake

- Press **◀** or **▶** to move the cursor to the incorrect number, and make the correction.

Setup

Setting your logo

The logo can be your company, division or name.

1 Press **MENU**.

Display: SYSTEM SET UP
PRESS NAVI. [◀ ▶]

2 Press **◀** or **▶** until the following is displayed.

YOUR LOGO
PRESS SET

3 Press **SET**.

LOGO=

4 Enter your logo, up to 30 characters, using the dial keypad. See the next page for details.

Example: "Bill"

1. Press **2** 2 times.

Cursor
LOGO=B

2. Press **4** 6 times.

LOGO=Bi

3. Press **5** 6 times.

LOGO=Bi1

4. Press **▶** to move the cursor to the next space and press **5** 6 times.

LOGO=Bi11

5 Press **SET**.
• The next feature will be displayed.

YOUR FAX NO.
PRESS SET

6 Press **MENU** to exit the program.

Note:

- You can enter your logo by pressing **+** or **-** (see the next page) in step 4. In this case, press **▶** to move the cursor.

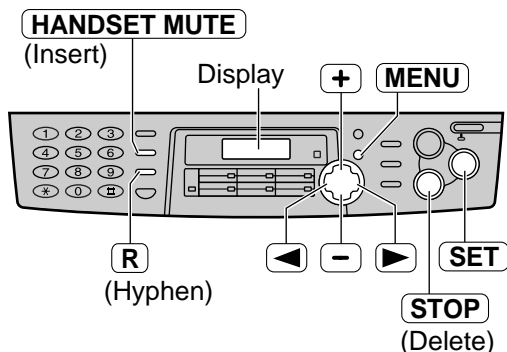

To change capital or lower-case letters

Pressing the **□** key will change to capital or lower-case alternatively.

1. Press **2** 2 times.

Display: LOGO=B

2. Press **4** 3 times.

LOGO=Bi

3. Press **□**.

LOGO=Bi

4. Press **5** 3 times.

LOGO=Bi1

To correct a mistake

- Press **◀** or **▶** to move the cursor to the incorrect character, and make the correction.

To delete a character

- Move the cursor to the character you want to delete and press **STOP**.

To insert a character

1. Press **◀** or **▶** to move the cursor to the position to the right of where you want to insert the character.
2. Press **HANDSET MUTE** to insert a space and enter the character.

To select characters with the dial keypad

Pressing the dial keys will select a character as shown below.

Keys	Characters
1	1 [] { } + - / = , . _ ` : ; ?
2	A B C a b c 2
3	D E F d e f 3
4	G H I g h i 4
5	J K L j k l 5
6	M N O m n o 6
7	P Q R S p q r s 7
8	T U V t u v 8
9	W X Y Z w x y z 9
0	0 () < > ! " # \$ % & ¥ * @ ^ ' →
⇄	To change capital or lower-case letter.
R	Hyphen button (To insert a hyphen.)
HANDSET MUTE	Insert button (To insert one character or one space.)
STOP	Delete button (To delete a character.)
▶	▶ key (To move the cursor to the right.) To enter another character using the same number key, move the cursor to the next space.
◀	◀ key (To move the cursor to the left.)

To select characters using + or -

Instead of pressing the dial keys, you can select characters using + or -.

1. Press + or - until the desired character is displayed.
2. Press ▶ to move the cursor to the next space.
 - The character displayed in step 1 is inserted.
3. Return to step 1 to enter the next character.

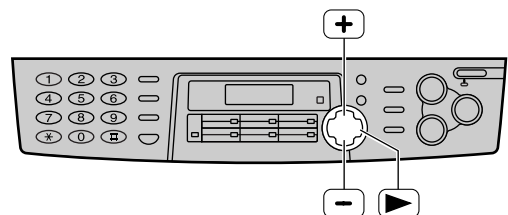

Display order of characters

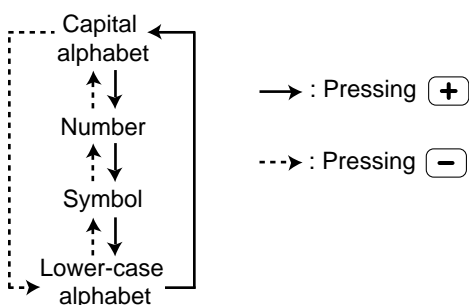

Setup

Setting your facsimile telephone number

1 Press **MENU**.

Display: SYSTEM SET UP
PRESS NAVI. [◀ ▶]

2 Press **◀** or **▶** until the following is displayed.

YOUR FAX NO.
PRESS SET

3 Press **SET**.

NO. =

4 Enter your facsimile telephone number, up to 20 digits, using the dial keypad.

Example: NO. =1234567

5 Press **SET**.

- The next feature will be displayed.

SENDING REPORT
=ERROR [±]

6 Press **MENU** to exit the program.

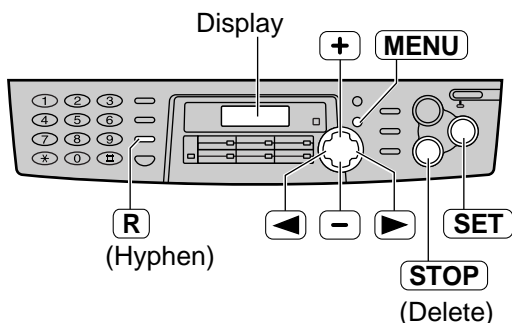

Note:

- You can enter your facsimile telephone number by pressing **+** or **-** in step 4. In this case, press **▶** to move the cursor.
- The ***** button replaces the digit with a "+" and the **□** button replaces it with a space.
Example (using the dial keypad): +234 5678
Press ***** **2** **3** **4** **□** **5** **6** **7** **8**.
- To enter a hyphen in a telephone number, press **R**.

To correct a mistake

- Press **◀** or **▶** to move the cursor to the incorrect number, and make the correction.

To delete a number

- Move the cursor to the number you want to delete and press **STOP**.

Adjusting volume

Ringer volume

4 levels (high/middle/low/off) are available.

While the unit is idle, press **+** or **-**.

To turn the ringer off:

1. Press **-** repeatedly until the following is displayed.

Display:

RINGER OFF= OK?
YES: SET/NO: STOP

2. Press **SET**.

RINGER OFF

- To turn the ringer back on, press **+**.

While the ringer volume is set to off:

When a call is received, the unit will not ring and will display the following.

INCOMING CALL

Monitor volume

8 levels (high to low) are available.

While using the monitor, press **+** or

-.

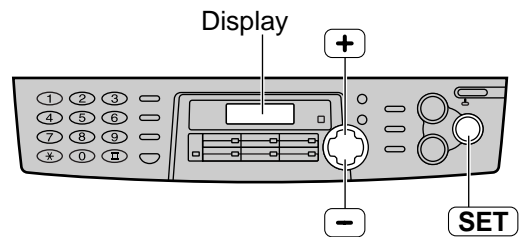

Ringer pattern

- You can select one of three ringer patterns. Change the setting (feature #17 on page 62). The ringer pattern you selected will sound when the unit receives a call.

R button (to use the recall feature)

R is used to access special telephone services (optional) such as call waiting. Contact your telephone company business office for details.

Example: Call waiting

When a call waiting tone is heard during a conversation:

To hold the existing call and accept the waiting call

Press **R**.

- Each time you press **R**, you can switch between the first and second call.

Incoming calls cannot be dropped by the person who has received the call.

If your unit is connected to a PBX, pressing **R** allows you to access some features of your host PBX such as transferring an extension call.

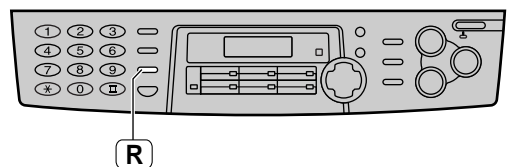

Automatic Dialling

Storing names and telephone numbers into one-touch dial

For rapid access to frequently dialled numbers, the unit provides 12 entries for one-touch dial.

- Stations 1 to 3 can be used alternatively as broadcast keys (p. 38).

- 1** Press **MENU** repeatedly until the following is displayed.

Display:

DIRECTORY SET PRESS STATION OR
↑
DIRECTORY SET PRESS NAVI. [◀ ▶]

- 2** For stations 1–3:
Press one of the station keys.

Example:

STATION 1 DIAL MODE [±]

Press **SET** to go to the next prompt.

For stations 4–6:

Press one of the station keys.

For stations 7–12:

Press **LOWER**, then press one of the station keys.

- 3** Enter the name, up to 10 characters (see page 23 for instructions).

Example:

NAME=John STORE:PRESS SET

- 4** Press **SET**.

Example:

<S01>=

- 5** Enter the telephone number, up to 30 digits, using the dial keypad.

Example:

<S01>=1114497

- If you want to enter a hyphen, press **R**.

- 6** Press **SET**.

REGISTERED
↓
DIRECTORY SET PRESS STATION OR
↑
DIRECTORY SET PRESS NAVI. [◀ ▶]

- To program other entries, repeat steps 2 to 6.

- 7** Press **STOP** to exit the program.

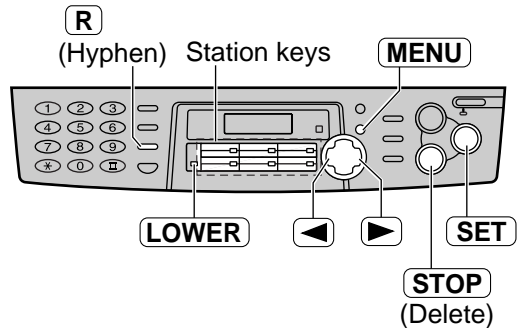

Helpful hint:

- You can confirm the stored entries on the telephone number list (p. 80).

Note:

- A hyphen or a space entered in a telephone number counts as two digits.

To correct a mistake

- Press **◀** or **▶** to move the cursor to the incorrect character/number, and then make the correction.

To delete a character/number

- Move the cursor to the character/number you want to delete, and press **STOP**.

Storing names and telephone numbers into navigator directory

For rapid access to frequently dialled numbers, the unit provides the navigator directory (100 entries).

- 1** Press **MENU** repeatedly until the following is displayed.

Display:

DIRECTORY SET PRESS STATION OR



DIRECTORY SET PRESS NAVI. [◀ ▶]

- 2** Press **◀** or **▶**.

NAME= STORE:PRESS SET

- 3** Enter the name, up to 10 characters (see page 23 for instructions).

Example:

NAME=Alice STORE:PRESS SET

- 4** Press **SET**.

NO. =

- 5** Enter the telephone number, up to 30 digits, using the dial keypad.

Example:

NO. =5552233

- If you want to enter a hyphen, press **R**.

- 6** Press **SET**.

REGISTERED



NAME= STORE:PRESS SET

- To program other entries, repeat steps 3 to 6.

- 7** Press **MENU** to exit the program.

Helpful hint:

- You can confirm the stored entries on the telephone number list (p. 80).

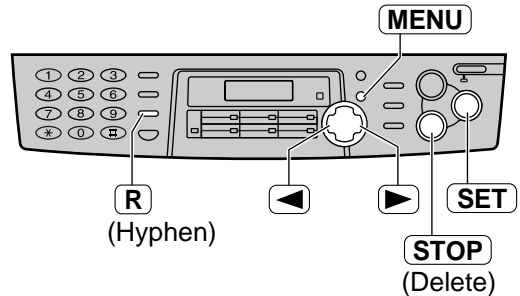

Note:

- When the following is displayed in step 6, you can store only 5 more entries.

Display:

REGISTERED SPACE= 5 DIRS.

- If there is no space to store new entries, the following is displayed in step 6.

REGISTERED DIRECTORY FULL

Erase unnecessary entries (p. 28).

- A hyphen or a space entered in a telephone number counts as two digits.

To correct a mistake

- Press **◀** or **▶** to move the cursor to the incorrect character/number, and then make the correction.

To delete a character/number

- Move the cursor to the character/number you want to delete, and press **STOP**.

Automatic Dialling

Editing a stored entry

You can edit a name or number that is stored in one-touch dial and navigator directory.

- 1** Press or .

Display: DIRECTORY [+ -]

- 2** Press or until the desired entry is displayed.

Example: Mary <S02>
0123456
↓
Mary <S02>
EDIT:PRESS MENU
↓
Mary <S02>
SEND:PRESS SET

- 3** Press **MENU**.

Example: NAME=Mary
EDIT=* DELETE=#

- 4** Press to select "EDIT".

Example: NAME=Mary
STORE:PRESS SET

- If you do not need to edit the name, skip to step 6.

- 5** Edit the name (see page 23 for instructions).

- 6** Press **SET**.

Example: <S02>=0123456

- If you do not need to edit the telephone number, skip to step 8.

- 7** Edit the telephone number. For further details, see page 27.

- 8** Press **SET**.

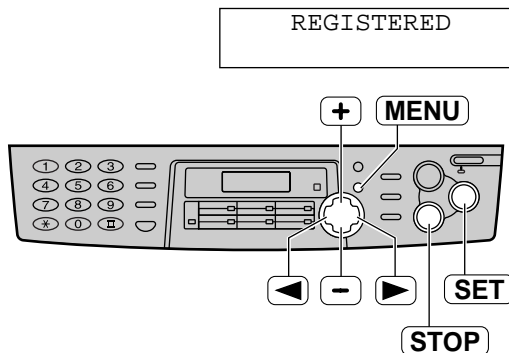

Erasing a stored entry

You can erase an entry stored in one-touch dial and navigator directory.

- 1** Press or .

Display: DIRECTORY [+ -]

- 2** Press or until the desired entry is displayed.

Example: Peter
9876543
↓
Peter
EDIT:PRESS MENU
↓
Peter
SEND:PRESS SET

- 3** Press **MENU**.

Example: NAME=Peter
EDIT=* DELETE=#

- 4** Press to select "DELETE".

DELETE OK?
YES:SET/NO:STOP

- To cancel erasing, press **STOP**.

- 5** Press **SET**.

DELETED

- The stored name and number are erased.

Making a phone call using one-touch dial and navigator directory

Before using this feature, program the desired names and telephone numbers into one-touch dial and navigator directory (p. 26, 27).

Using one-touch dial

- 1 Press **MONITOR** or lift the handset.

Display: TEL=
PRESS STATION OR

↑

TEL=
PRESS NAVI. [◀ ▶]

- 2 For stations 1–6:
Press the desired station key.

Example: TEL=<John>

For stations 7–12:

Press **LOWER**, then press the desired station key.

- The unit will start dialling automatically.

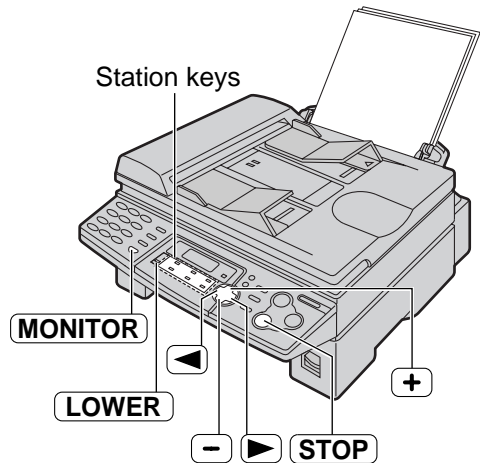

Using the directory

- 1 Press **◀** or **▶**.

Display: DIRECTORY [+ -]

- 2 Press **+** or **-** until the desired entry is displayed.

Example: Lisa
2233445

↓

Lisa
EDIT:PRESS MENU

↓

Lisa
SEND:PRESS SET

- If the desired name has not been stored, press **STOP** and dial the number manually.

- 3 Press **MONITOR** or lift the handset.
 - The unit will start dialling automatically.

To search for a name by initial

Example: "Lisa"

1. Press **◀** or **▶**.
2. Press **+** or **-** to enter the directory.
3. Press **5** repeatedly until any name with the initial "L" is displayed (see the character table on page 23).

- To search for symbols (not letters or numbers), press *****.

4. Press **+** until "Lisa" is displayed.
 - To stop the search, press **STOP**.
 - To make a call, press **MONITOR** or lift the handset.

Caller ID service from your phone company

This unit is compatible with the Caller ID service offered by your local telephone company. To use this feature, you must subscribe to the Caller ID service.

Important:

- This unit is designed in accordance with the “FSK based subscriber line protocol” under the ETS (European Telecommunication Standard) and only supports the basic CLIP (Calling Line Identification Presentation) features.
- This unit will only display the caller’s telephone number and name.
- This unit will not support future additional telephone services.
- This unit cannot support services based on the “DTMF based subscriber line protocol”.
- Depending on the service of the local telephone company, the date/time of the call or the caller’s name may not be displayed.

Change the FAX ring setting (feature #06 on page 61) to 2 or more rings beforehand.

How Caller ID is displayed

The calling party’s name or telephone number will be displayed after the first ring. You then have the option of whether or not to answer the call depending on the caller.

The unit will automatically store the caller information (name, telephone number and the time of the call). You can view the caller information (see the next page) and print the caller ID list (p. 80).

Note:

- If the unit is connected to a PBX (Private Branch Exchange) system, you may not receive the caller information. Consult your PBX supplier.
- If the unit cannot receive caller information, the following will be displayed.

OUT OF AREA

The caller dialed from an area which does not provide Caller ID service.

PRIVATE CALLER

The caller requested not to send caller information.

OR

WITHHELD

The caller requested not to send caller information.

LONG DISTANCE

The caller made a long distance call.

To confirm caller information using the Caller ID list

The unit will store information for the most recent 30 callers.

— To print manually, see page 80.

— To print automatically after every 30 new calls, activate feature #26 (p. 64).

Viewing and calling back using caller information

You can easily view caller information and call back.

Important:

- Calling back will not be possible in the following cases:
 - The telephone number includes data other than numbers (i.e. * or #).
 - The caller information does not include a telephone number.

1 Press **CALLER ID**.

Example:

2 NEW CALLS PRESS NAVI. [+ -]

(2 new calls are received)

2 Press **+** to search from the most recent caller information.

Press **-** to search from the oldest caller information.

- To send a fax using the scanner glass, see page 35.

3 Press **MONITOR** or lift the handset to call back the displayed party.

- The unit will start dialling automatically.
- To send a fax using the auto document feeder – insert the document **FACE DOWN** into the feeder and press **FAX START** (p. 34).

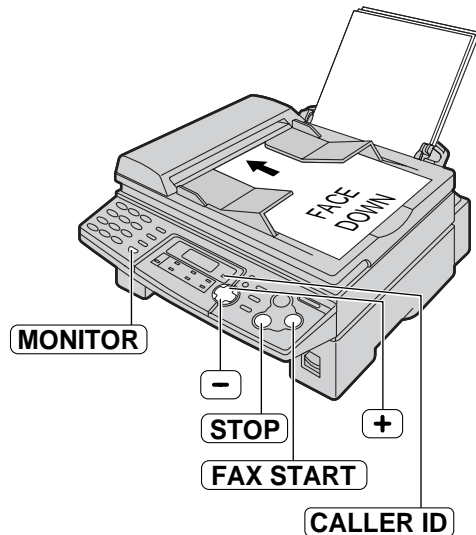

To display the caller's telephone number

Press **CALLER ID** repeatedly after step 2.

Example:

1345678901 20 Jul. 11:20AM

 ↔

SAM LEE 20 Jul. 11:20AM ✓

 — This means this call has already been viewed or answered.

Display while viewing

NO NAME RCVD

 When the unit could not receive a name.

NO CALLER DATA

 When no calls have been received.

To stop viewing

Press **STOP** after step 2.

Erasing caller information

- 1** Press **MENU** repeatedly until the following is displayed.

Display: CALLER SET UP
PRESS SET

- 2** Press **SET**.

CALL LIST ERASE
PRESS SET

- 3** Press **SET**.

ERASE ALL OK?
YES : SET / NO : STOP

- To cancel erasing, press **STOP**, then **MENU**.

- 4** Press **SET**.

ERASE COMPLETED

- 5** Press **STOP** to exit the program.

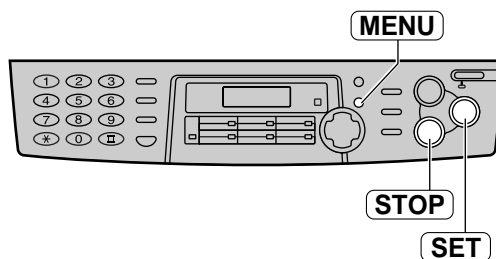

Storing caller information into one-touch dial and navigator directory

Important:

- This feature is not available in the following cases:
 - The telephone number includes data other than numbers (i.e. * or #).
 - The caller information does not include a telephone number.

1 Press **CALLER ID**.

Example:

2 NEW CALLS PRESS NAVI. [+ -]

2 Press **+** or **-** until the desired entry is displayed.

Example:

134567890 14 Apr. 11:50AM

3 Press **MENU**.

Example:

134567890 PRESS STATION OR

↑↓

134567890 PRESS NAVI. [◀ ▶]

4 For stations 1–3:
Press the desired station key.

Example:

STATION 1 DIAL MODE [±]

Press **SET**.

NAME= STORE:PRESS SET

Press **SET**.

Example:

<S01>=134567890

For stations 4–6:
Press the desired station key.

NAME= STORE:PRESS SET

Press **SET**.

Example:

<S04>=134567890

For stations 7–12:
Press **LOWER**, then press the desired station key.

NAME= STORE:PRESS SET

Press **SET**.

Example:

<S09>=134567890

For navigator directory:

Press **◀** or **▶**.

NAME= STORE:PRESS SET

Press **SET**.

Example:

NO.=134567890

5 Press **SET**.

REGISTERED

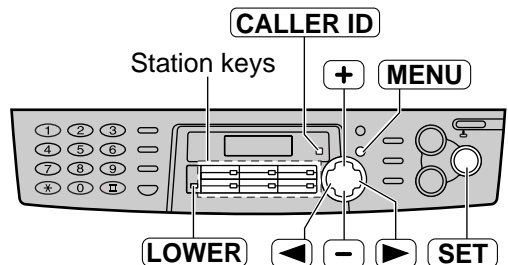

Note:

- You can confirm the stored entries on the telephone number list (p. 80).
- The unit can only store a name of up to 10 characters long.
- To edit a name and number, see page 28.
- If you enter a new entry into a station key, the previous entry will be overwritten.
- If you use stations 1–3 as broadcast keys, you cannot store caller information for stations 1–3.

Sending Faxes

Sending a fax manually

Using the auto document feeder

- Confirm that there are no documents on the scanner glass.

- 1 Adjust the width of the document guides to the size of the document.
- 2 Insert the document (up to 15 pages) **FACE DOWN** into the feeder until the unit grasps the document and a single beep is heard.

Display: STANDARD

- 3 If necessary, press **RESOLUTION** repeatedly to select the desired setting (see below).

- 4 Press **MONITOR** or lift the handset.

TEL=
PRESS STATION OR
↑↓
TEL=
PRESS NAVI . [◀ ▶]

- 5 Dial the fax number.

Example: TEL=5678901

- 6 **When a fax tone is heard:**
Press **FAX START**, and replace the handset if you are using it.
OR

When the other party answers your call:
Lift the handset and ask them to press their start button. When the fax tone is heard, press **FAX START** and replace the handset.

CONNECTING
STANDARD

To select the resolution

Select the desired resolution according to the type of document.

- **STANDARD:** For printed or typewritten originals with normal-sized characters.
- **FINE:** For originals with small printing.
- **SUPER FINE:** For originals with very small printing. This setting only works with other compatible fax machines.
- **PHOTO:** For originals containing photographs, shaded drawings, etc.

- Using the “FINE”, “SUPER FINE” or “PHOTO” setting will increase transmission time.
- If the resolution setting is changed during feeding, it will be effective from the next sheet.

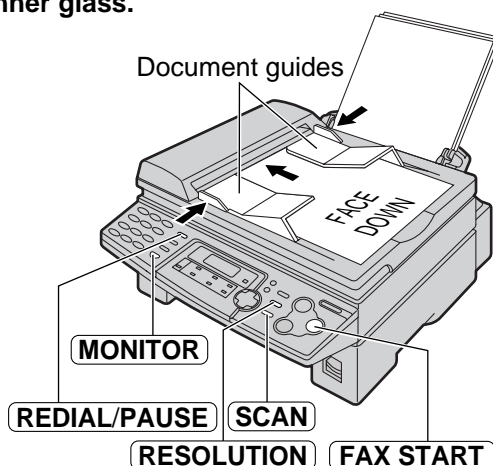

Note:

- Do not open the document cover when sending a fax with the auto document feeder.

To redial the last number

Press **REDIAL/PAUSE**.

- If the line is busy, the unit will automatically redial the number up to 5 times.
- During redial, the following will be displayed.

Display: WAITING REDIAL

To transmit more than 15 pages at a time

Insert the first 15 pages of the document. Add the other pages (up to 15 at a time) before the last page feeds into the unit.

Convenient way to send a fax

You can dial the fax number before inserting the document. This is convenient if the other party's number is indicated on the document.

1. Enter the fax number.
 - The handset must be on the cradle.
2. Insert the document.
3. Press **FAX START**.

Sending from memory

• Quick scan feature

You can scan the document into memory before sending.

1. Insert the document.
2. Enter the fax number.
3. Press **SCAN**.

• Transmitting reservation (Dual Access) feature

You can send the document even when the unit is just receiving a fax or sending a fax from memory.

1. Insert the document during fax reception or fax memory transmission.
2. Enter the fax number using the dial keypad, one-touch dial or navigator directory.
3. Press **SCAN** or **FAX START**.

- The document will be fed into the unit and scanned into memory. The unit will then transmit the data.

If the document exceeds the memory capacity (p. 81), sending will be cancelled. Transmit the entire document manually.

Note:

- Transmitting reservation (Dual Access) feature is not available when using the scanner glass.

Using the scanner glass

By using the scanner glass, you can send a page from booklets or small sized paper that cannot be sent with the auto document feeder.

• Confirm that there are no documents in the auto document feeder.

1 Open the document cover.

2 Place the document **FACE DOWN** on the scanner glass, matching the top edge of the document to the “▽” mark on the unit.

3 Close the document cover.

- If the original is a thick book, do not close the document cover.

4 If necessary, press **RESOLUTION** repeatedly to select the desired setting (p. 34).

5 Enter the fax number.

Example:

NO.=5678901

- To send a single page, skip to step 9.
- To send multiple pages, go to the next step.

6 Press **SCAN** to scan the document into memory.

Example:

PAGES=01	01%
STANDARD	

↓

NEXT:PRESS SCAN
SEND:PRESS START

7 Place the next page on the scanner glass.

8 Press **SCAN**.

NEXT:PRESS SCAN
SEND:PRESS START

- To send more pages, repeat steps 7 and 8.

9 Press **FAX START**.

CONNECTING.....

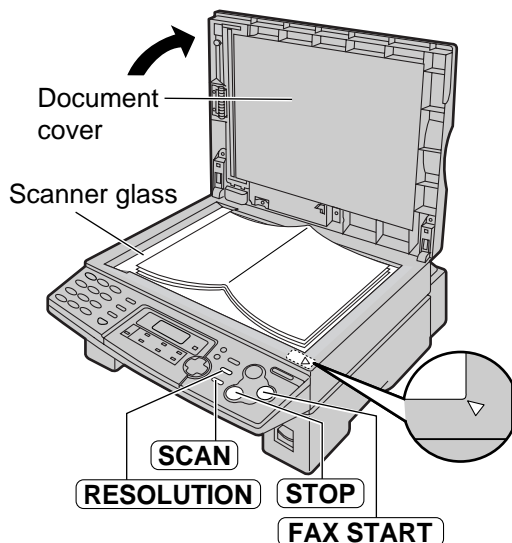

Note for the auto document feeder and the scanner glass

To stop transmission

Press **STOP**.

Sending report for confirmation

This report will provide you with a printed record of transmission results. To use this feature, activate feature #04 (p. 61). For the communication message in the result column, see page 66.

Journal report

The unit stores the 30 most recent fax communication results.

- To print manually, see page 80.
- To print automatically after every 30 new fax communications, activate feature #22 (p. 63). For the communication message in the result column, see page 66.

Sending Faxes

Documents you can send

Using the auto document feeder

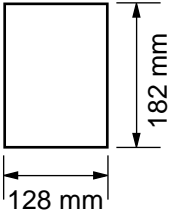
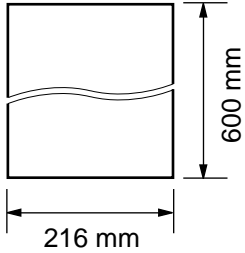
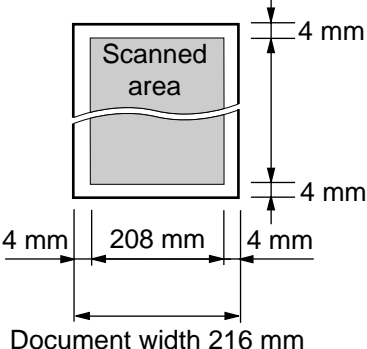
Minimum size	Maximum size	Effective scanning area	Document weight
			Single sheet: 45 g/m ² to 90 g/m ² Multiple sheets: 60 g/m ² to 80 g/m ²

Note:

- Remove clips, staples or other similar fasteners.
- Do not send the following types of documents: (Use the scanner glass for fax transmission.)
 - Chemically treated paper such as carbon or carbonless duplicating paper
 - Electrostatically charged paper
 - Badly curled, creased or torn paper
 - Paper with a coated surface

Using the scanner glass

Effective scanning area on the scanner glass

Effective scanning area is changed depending on the setting of the paper size (feature #16 on page 62).

When the paper size is set to "A4":

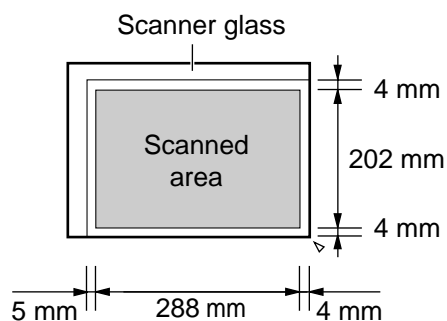

When the paper size is set to "LETTER":

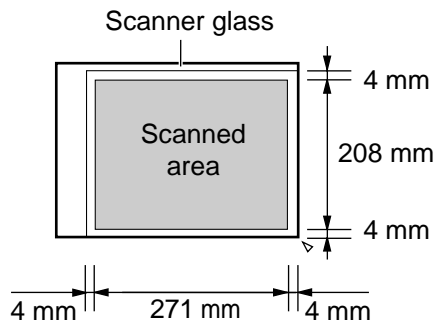

Note for the auto document feeder and the scanner glass

- Check that ink, paste or correction fluid has dried completely.
- Do not send the following types of documents: (Use copies for fax transmission.)
 - Paper with a faint image
 - Paper with printing on the opposite side that can be seen through the other side (i.e. newspaper)
- To transmit the document with a width of less than A4 size (210 mm), we recommend transmitting the document using the scanner glass.

Sending a fax using one-touch dial and navigator directory

Before using this feature, program the desired names and telephone numbers into one-touch dial and navigator directory (p. 26, 27).

- 1 Adjust the width of the document guides to the size of the document.
- 2 Insert the document (up to 15 pages) FACE DOWN into the feeder until the unit grasps the document and a single beep is heard.
 - Confirm that there are no documents on the scanner glass.

Display: STANDARD

- 3 If necessary, press **RESOLUTION** repeatedly to select the desired setting (p. 34).

- 4 Enter the fax number.
Using stations 1–6:
Press the desired station key.

Using stations 7–12:

Press **LOWER**, then press the desired station key.

Using navigator directory:

Press **◀** or **▶**, then press **+** or **-** to display the desired entry.

- For further details about using the directory, see page 29.

- 5 Press **FAX START**.

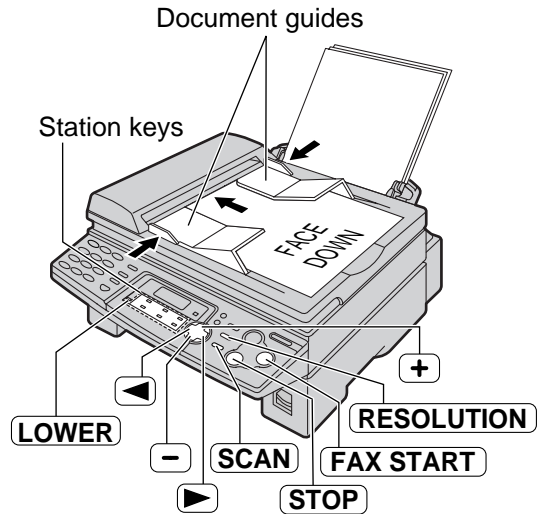

Note:

- Do not open the document cover when sending a fax with the auto document feeder.

To send a fax using the scanner glass

- Confirm that there are no documents in the auto document feeder.

1. Open the document cover.
2. Place the document FACE DOWN, then close the document cover.
3. Enter the fax number (see step 4 above).
 - To send a single page, skip to step 7.
 - To send multiple pages, go to the next step.
4. Press **SCAN** to scan the document into memory.
5. Place the next page.
6. Press **SCAN**.
 - To send more pages, repeat steps 5 and 6.
7. Press **FAX START**.

Fax auto redial

If the line is busy or if there is no answer, the unit will automatically redial the number up to 5 times.

- This feature is also available for delayed transmission (feature #25 on page 63).
- During redial, the following will be displayed.

Display: WAITING REDIAL

- To cancel redialing, press **STOP**.

If your unit does not send a fax

- Confirm the stored telephone number on the display and check that the number dialled is answered by the other party's machine (p. 29).
- The connecting tone will be heard during dialling to tell you the status of the other party's machine (feature #76 on page 65).

Sending Faxes

Broadcast transmission

This feature is useful for sending the same document to selected parties (up to 20 entries). First program the entries, then see page 41 for transmission.

- The broadcast function utilises stations 1–3. The one-touch dial function will be cancelled.
- **BROADCAST** key 1 and 2 can accept one-touch dial and navigator entries.
- **MANUAL BROADCAST** key can also accept manual dialling entries.

Programming entries into the broadcast memory

- 1 Press **MENU** repeatedly until the following is displayed.

Display:

DIRECTORY SET PRESS STATION OR

↑

DIRECTORY SET PRESS NAVI. [◀ ▶]

- 2 For **BROADCAST** 1–2:
Press the desired **BROADCAST** key.

Example:

STATION 1 DIAL MODE [±]

Press **+** or **-** to select "BROADCAST".

Example:

STATION 1 BROADCAST [±]

For **MANUAL BROADCAST**:

Press **MANUAL BROAD**.

STATION 3 DIAL MODE [±]

Press **+** or **-** to select "MANUAL BROAD".

STATION 3 MANUAL BROAD [±]

- 3 Press **SET**.

DIR= [00]
NAVI. [+ -] & SET

- 4 Program entries.
Using stations 1–6:
Press the desired station key.

Example:

DIR=ANN [01]
NAVI. [+ -] & SET

Using stations 7–12:

Press **LOWER**, then press the desired station key.

Using navigator directory:

Press **+** or **-** until the desired entry is displayed and press **SET**.

Using the dial keypad (only for **MANUAL BROAD**):

Enter the fax number and press **SET**.

Example:

DIR=3456789

↓

DIR=3456789 [01]
NAVI. [+ -] & SET

- To program other entries, repeat this step (up to 20 entries).

- 5 Press **SET** after programming all of the desired entries.

REGISTERED

↓

DIRECTORY SET PRESS STATION OR

↑

DIRECTORY SET PRESS NAVI. [◀ ▶]

- To program another broadcast key, repeat steps 2 to 5.

- 6 Press **STOP** to exit the program.

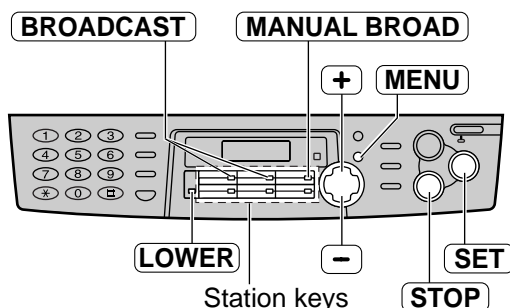

Note:

- If you program the wrong entry, press **STOP** after step 4 to erase the entry.
- Confirm the stored entries by printing a broadcast programming list (p. 80).

Adding a new entry into the broadcast memory

1 Press **◀** or **▶**.

Display:

DIRECTORY [+ -]

2 Press **+** or **-** until the following is displayed.

Example:

<BROADCAST1> EDIT:PRESS MENU

↓

<BROADCAST1> SEND:PRESS SET

3 Press **MENU**.

<BROADCAST1> ADD=* DELETE=#

4 Press ***** to select "ADD".

5 Press **+** or **-** until the desired entry you want to add is displayed.

Example (Navigator):

Mary 15843724123

Example (Station 2):

Peter <S02> 19265532168

6 Press **SET**.

REGISTERED

↓
Example:

Nikki 13852179365

- To add other entries, repeat steps 5 and 6 (up to 20 entries).

7 Press **STOP** to exit the program.

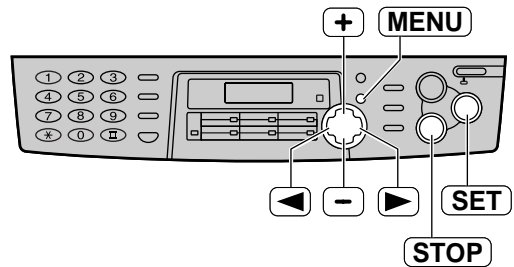

Sending Faxes

Erasing a stored entry in the broadcast memory

1 Press **◀** or **▶**.

Display:

DIRECTORY	[+ -]
-----------	---------

2 Press **+** or **-** until the following is displayed.

Example:

<BROADCAST1> EDIT:PRESS MENU

↑

<BROADCAST1> SEND:PRESS SET

3 Press **MENU**.

<BROADCAST1> ADD=* DELETE=#

4 Press **▣** to select "DELETE".

5 Press **+** or **-** until the desired entry you want to erase is displayed.

Example (Navigator):

Dick
13281432968

Example (Station 3):

Sam	<S03>
19876543210	

• To cancel erasing, press **STOP**.

6 Press **SET**.

DELETE OK?
YES:SET/NO:STOP

7 Press **SET**.

DELETED

↓
Example:

Bob
0123456

• To erase other entries, repeat steps 5 to 7.

8 Press **STOP** to exit the program.

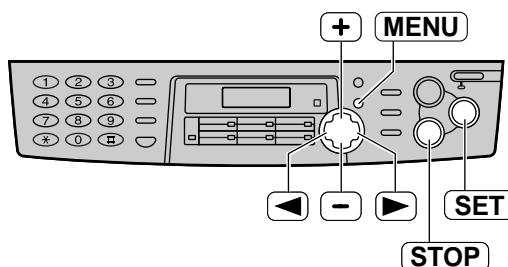

Sending the same document to pre-programmed parties

- 1** Insert the document **FACE DOWN** into the feeder.
 - Confirm that there are no documents on the scanner glass.
 - If necessary, press **RESOLUTION** repeatedly to select the desired setting (p. 34).

- 2** Press the desired **BROADCAST** (1–2) or **MANUAL BROAD**.
 - You can also use the navigator key. Press **▶**, then press **+** or **-** until the desired key name is displayed, and press **FAX START**.

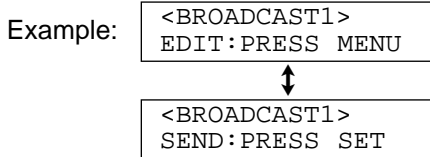

- The document will be fed into the unit and scanned into memory. The unit will then transmit the data to each entry, calling each number sequentially.
- After transmission, the stored document will be erased automatically, and the unit will automatically print a broadcast sending report.

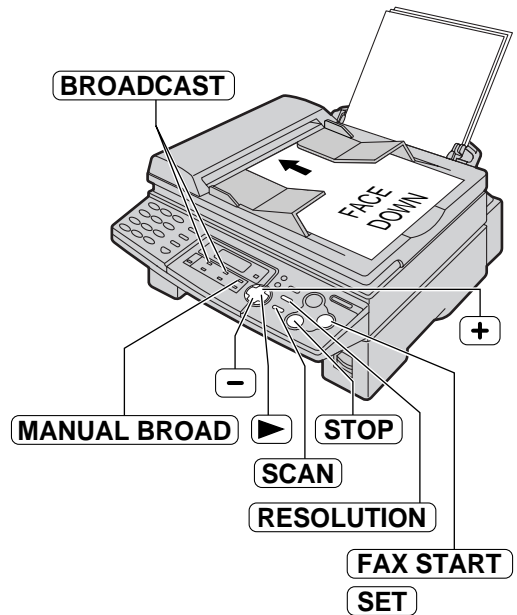

Note:

- Do not open the document cover when sending a fax with the auto document feeder.
- If you select the “FINE”, “SUPER FINE” or “PHOTO” resolution, the number of pages that the unit can transmit will decrease.
- If the document exceeds the memory capacity (p. 81), sending will be cancelled.
- If one of the entries is busy or does not answer, it will be skipped. All skipped entries will be redialled up to 5 times after all of the other entries have been called.

To send the same document using the scanner glass

- Confirm that there are no documents in the auto document feeder.
1. Open the document cover.
 2. Place the document **FACE DOWN**, then close the document cover.
 3. Press the desired **BROADCAST** (1–2) or **MANUAL BROAD**.
 - To send a single page, skip to step 6.
 - To send multiple pages, go to the next step.
 4. Place the next page.
 5. Press **SCAN**.
 - To send more pages, repeat steps 4 and 5.
 6. Press **FAX START**.

To cancel the broadcast setting

1. Press **STOP** while the unit displays the following.

Display: BROADCASTING

- The display will show the following.

SEND CANCELLED?
 YES: SET/NO: STOP

2. Press **SET**.

Receiving Faxes

Setting the unit to receive faxes

Use only as a fax

With answering machine

How you want the unit to receive calls

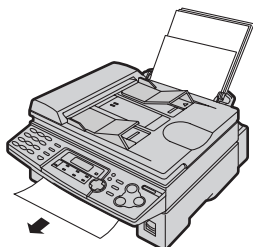

You have a separate telephone line just for faxes.

External telephone answering machine (not included)

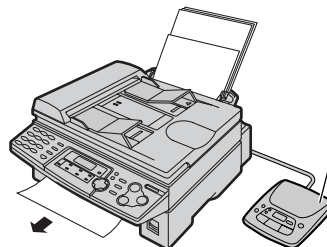

You want to use the fax machine with an answering machine.

Set the unit this way.

FAX ONLY mode (p. 45)

Turn AUTO ANSWER on by pressing **AUTO ANSWER**.

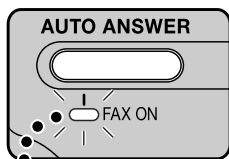

ON

Activating an answering machine (p. 46)

Connect an external telephone answering machine and change the ring setting of the answering machine to less than 4.

- Change the ring setting in FAX ONLY mode of the fax machine to more than 4, if you use with AUTO ANSWER on.

This is how the unit will operate.

When receiving calls:
All incoming calls will be answered as faxes.

When receiving phone calls:

The answering machine will record voice messages.

When receiving faxes:
The fax machine will disconnect the answering machine and receive documents.

Mostly phone calls

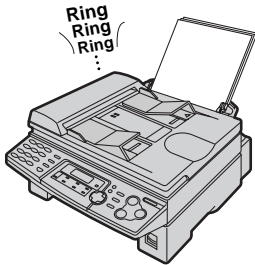

You plan to answer the calls yourself.



TEL mode (p. 44)

Turn AUTO ANSWER off by pressing **AUTO ANSWER**.

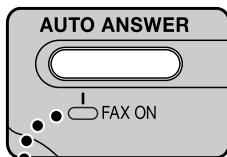

OFF



When receiving calls:

You have to answer all calls manually.

To receive a fax document, press **FAX START** for each fax you are receiving.

Other option

Remote fax activation

You can also receive a fax using an extension telephone. While hearing a fax calling tone with an extension telephone, press *** 9** (pre-selected fax activation code) to receive a fax (p. 47).

Receiving Faxes

TEL mode (answering all calls manually)

Activating TEL mode

If the FAX ON light is on, turn it off by pressing

AUTO ANSWER.

Display:

TEL MODE

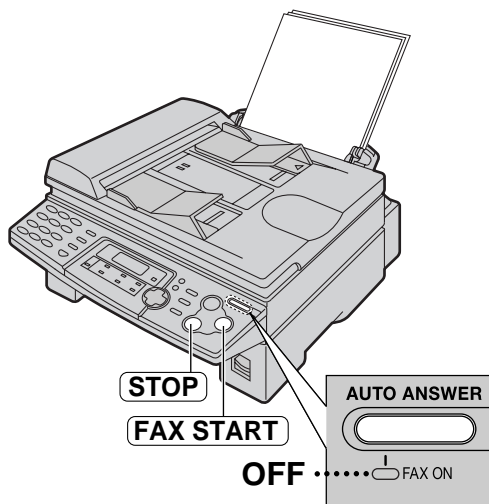

Receiving a fax manually

- 1 When the unit rings, lift the handset to answer the call.
- 2 When:
 - document reception is required,
 - a fax calling tone (slow beep) is heard, or
 - no sound is heard,press **FAX START**.

CONNECTING.....

- 3 Replace the handset.
 - The unit will start fax reception.

Note:

- If you do not answer the call within 10 rings, the unit will temporarily switch to fax reception. The other party can then send a fax.

To stop receiving

Press **STOP**.

Auto reduction feature

If the other party sends a document that is longer than your recording paper, your unit will reduce the receiving document to the proper size and print it. If you want to print the original size, set feature #37 to off (p. 64).

Fax reception in memory

When a printing problem is detected, the unit will temporarily store the received document into memory.

While the document is in memory:

- the display will show an error message and the following alternately,

Display: FAX IN MEMORY

- slow beeps will sound if feature #44 is set to on (p. 65).

- Follow the instructions on pages 67 and 68 to solve the problem.
- For memory capacity, see page 81.

FAX ONLY mode --- --- (all calls are received as faxes)

Activating FAX ONLY mode

If the FAX ON light is off, turn it on by pressing **AUTO ANSWER**.

Display: FAX ONLY MODE

- The unit will automatically answer all calls and only receive fax documents.

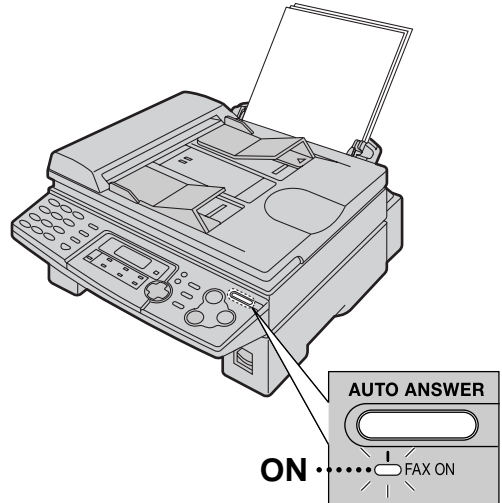

Note:

- The number of rings before a call is answered in FAX ONLY mode can be changed (feature #06 on page 61).
- This mode should not be used with a telephone line which is used for both phone calls and faxes. Fax communication will be attempted even if someone is trying to call you. We recommend the following setup:

Example:

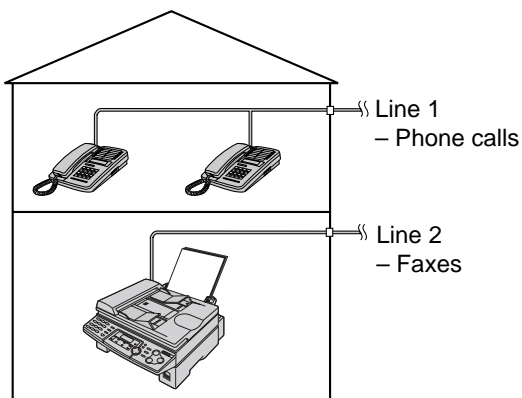

Only a fax machine is connected.

Receiving Faxes

Using the unit with an answering machine

Setting up the fax machine and an answering machine

- 1 Connect the answering machine.

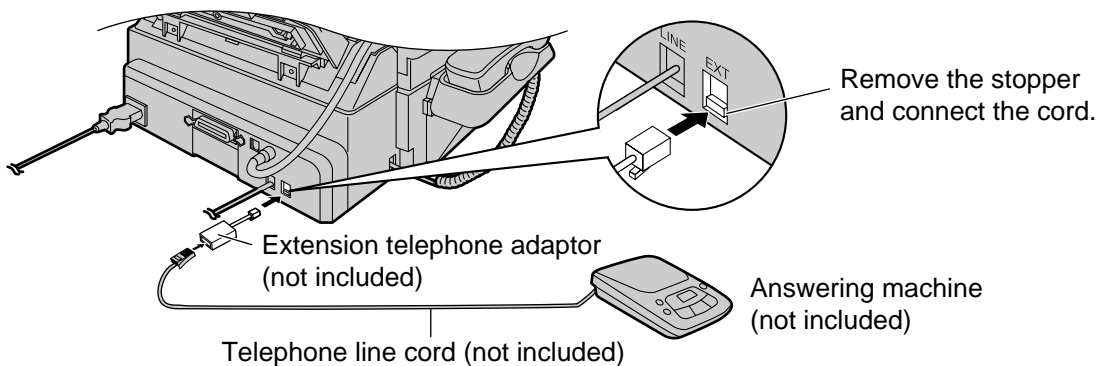

- 2 Set the number of rings on the answering machine to less than 4.
 - This will allow the answering machine to answer the call first.
- 3 Record a greeting message on the answering machine.

Example: *"This is (your name, business and/or telephone number). We are unable to answer the phone right now. To send a fax, start transmission. To leave a message, please speak after the beep. Thank you."*

 - We recommend you record a message up to 10 seconds long, and do not pause for more than 4 seconds during the message. Otherwise, both machines will not function correctly.
- 4 Activate the answering machine.
- 5 Set the fax machine to the desired receiving mode (p. 44, 45).
 - If you set to FAX ONLY mode, **change the ring setting in FAX ONLY mode to more than 4 (feature #06 on page 61)**. Using FAX ONLY mode will allow you to receive faxes if the answering machine is full.
- 6 Check the remote access code of the answering machine and program the same code into the remote operation ID of the fax machine. See feature #12 on page 61.

How the fax machine and answering machine work

Receiving phone calls

The answering machine will record voice messages automatically.

Receiving faxes

The fax machine will receive documents automatically when the machine detects a fax calling tone.

Receiving a voice message and fax document in one call

See below.

Note:

- Every time the fax machine receives a document, a silent pause or fax tone may be recorded on the answering machine.

Receiving a voice message and fax document in one call

The caller can leave a voice message and send a fax document during the same call.

Inform the caller of the following procedure beforehand:

1. The caller calls your fax machine.
 - The answering machine will answer the call.
2. The caller can leave a message after the greeting message.
3. The caller presses ***#9** (pre-selected fax activation code).
 - The fax machine will activate the fax function.
4. The caller presses the start button to send a document.

Note:

- The fax activation code can be changed in feature #41 (p. 64).

Extension telephone

If you use the fax machine with an extension telephone, you can receive fax documents using the extension telephone. You do not have to press **FAX START** on the fax machine.

Important:

- Use a touch tone telephone as the extension telephone and enter the fax activation code **firmly**.

- 1 When the extension telephone rings, lift the handset of the extension telephone.
- 2 When:
 - document reception is required,
 - a fax calling tone (slow beep) is heard, or
 - no sound is heard,press ***#9** (pre-selected fax activation code) **firmly**.
- 3 Hang up the handset.
 - The fax machine will start reception.

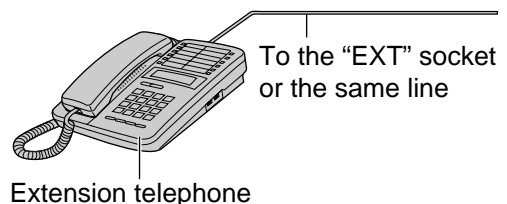

Note:

- You can change the fax activation code in feature #41 (p. 64).

Making a copy

The unit can make single or multiple copies (up to 99).

1 Using the auto document feeder

- Confirm that there are no documents on the scanner glass.

1. Adjust the width of the document guides to the size of the document.
2. Insert the document (up to 15 pages) FACE DOWN into the feeder until the unit grasps the document and a single beep is heard.

Display:

STANDARD

Using the scanner glass

- Confirm that there are no documents in the auto document feeder.

1. Open the document cover.
2. Place the document FACE DOWN on the scanner glass, matching the top edge of the document to the "▽" mark on the unit.
3. Close the document cover.
 - If the original is a thick book, do not close the document cover.

- If necessary, press **RESOLUTION** repeatedly to select the desired setting (see below).
- Make sure the handset is on the cradle.

2 Press **COPY START**.

100% FINE [01]
COPY:PRESS START

- If necessary, enter the number of copies (up to 99).

3 Press **COPY START**.

- The unit will start copying.

Note:

- Do not open the document cover when making a copy with the auto document feeder.
- Any transmittable document can be copied (p. 36).
- To make a clear copy from transparencies, be sure to use the scanner glass. Place a blank sheet of paper on the top of the transparency, and leave the document cover open during copying.

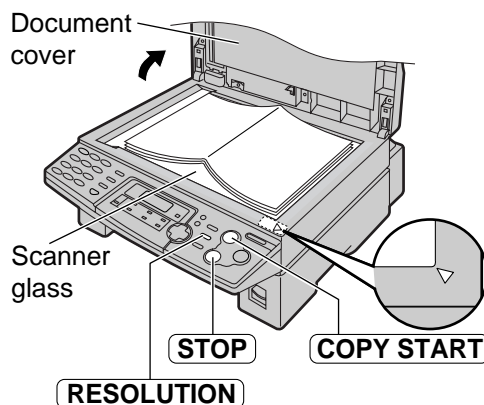
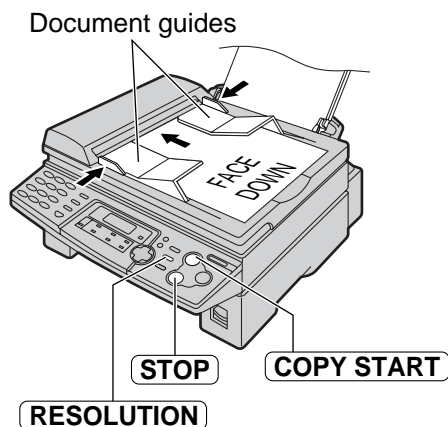

To select the resolution

Select the desired resolution according to the type of document.

- **FINE**: For printed or typewritten originals with small printing.
- **SUPER FINE**: For originals with very small printing.
- **PHOTO**: For originals containing photographs, shaded drawings, etc.

- If you select "STANDARD", copying will be done using "FINE" mode.
- You can also select the resolution after pressing **COPY START** in step 2. Press **RESOLUTION** repeatedly to select the desired setting.

To stop copying

Press **STOP**.

To enlarge a document

The unit can enlarge copies to as much as 200% of the original by changing the enlargement rate 5% at a time.

After step 2 on page 48, press **[+]** repeatedly to select the desired enlargement rate, then press **[COPY START]**.

- **When using the auto document feeder**, the unit will only enlarge the center of the upper part of the document. To make an enlarged copy of the bottom of the document, turn the document around, and then make a copy.
- **When using the scanner glass**, the unit will only enlarge the right bottom corner of the document starting from the “▽” mark on the unit.

Example: 150% enlarged copy

Using the auto document feeder:

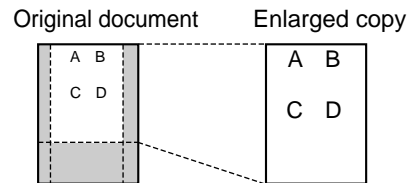

Using the scanner glass:

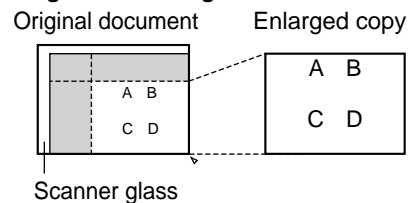

To reduce a document

The unit can reduce copies to as little as 50% of the original by changing the reduction rate 5% at a time.

After step 2 on page 48, press **[-]** repeatedly to select the desired reduction rate, then press **[COPY START]**.

Example: 70% reduced copy

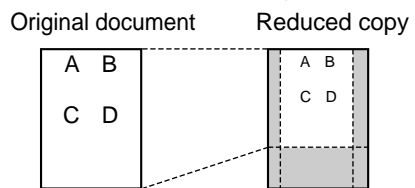

To collate multiple copies

The unit can collate multiple copies in the same order as the original document pages.

■ Using the auto document feeder

1. After step 2 on page 48, press **[COLLATE]** until the following is displayed.

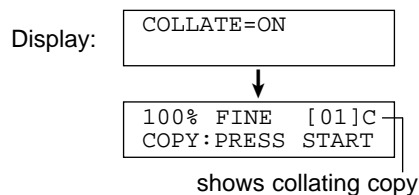

2. Press **[COPY START]**.

■ Using the scanner glass

1. After step 2 on page 48, press **[COLLATE]**.
2. Press **[COPY START]**.

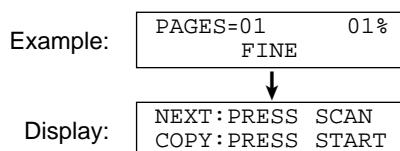

3. Place the next page.
4. Press **[SCAN]**.
 - To copy more pages, repeat steps 3 and 4.
5. Press **[COPY START]**.

Example: Making 2 copies of a 4-page original document

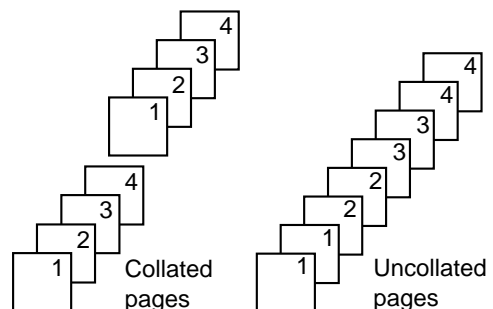

Note:

- The unit will store the documents into memory while collating the copies. If memory becomes full while storing, the unit will only print out the stored pages.
- After copying, the collating feature will turn off automatically.

Setup (PC)

Connecting to a computer

Panasonic Multi-Function Station software enables your fax machine to carry out the following functions:

- Printing on plain paper, transparencies, labels and envelopes
- Scanning documents and converting an image into text with Readiris OCR software
- Scanning from other applications for Microsoft® Windows® that support TWAIN scanning
- Storing, editing or erasing entries in directories from your PC
- Programming the basic and advanced features from your PC
- Sending, receiving fax documents using your PC

To run Multi-Function Station software, you need the following:

- OS: Works with Windows 95/98/Me/2000/XP and Windows NT® 4.0
- CPU: Windows 95/98: Pentium® 90 MHz or higher processor
Windows Me: Pentium 150 MHz or higher processor
Windows NT4.0: Pentium 133 MHz or higher processor
Windows 2000: Pentium 166 MHz or higher processor
Windows XP: Pentium 300 MHz or higher processor
- Memory minimum: Windows 95/98/NT4.0: 24 MB (32 MB or more is recommended.)
Windows Me: 32 MB (64 MB or more is recommended.)
Windows 2000: 64 MB
Windows XP: 128 MB
- Hard disk: More than 50 MB available space
- Other: Parallel (IEEE1284) port or USB port, and CD-ROM drive

■ When using an IEEE1284 compliant parallel cable:

Parallel cable (amphenol 36 pin, less than 3 metres long) must be purchased separately.

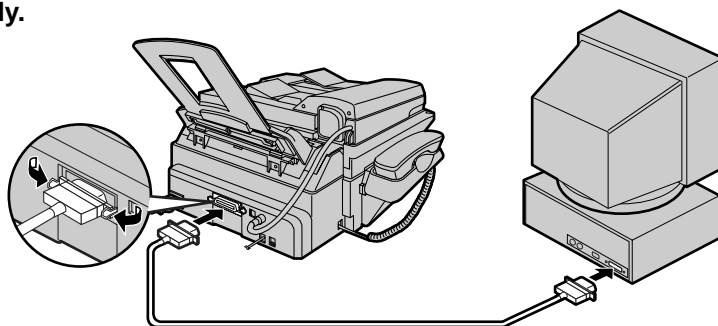

■ When using a USB cable (Windows 95/NT4.0 do not offer USB support):

USB cable (less than 3 metres long) must be purchased separately.

After connecting the USB cable, you must set the cable type to “USB” (feature #15 on page 62).

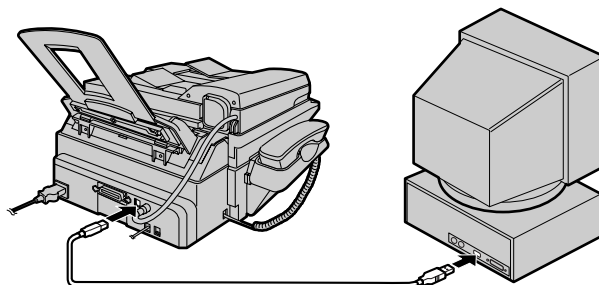

Note:

- If you want to replace the parallel cable with a USB cable and vice versa, see page 72.

Installing Multi-Function Station software

- 1 Connect the fax machine to the PC (page 50).
 - To use via USB connection, you must set the cable type to “USB” (feature #15 on page 62). The default setting is “PARALLEL”.
- 2 Start Windows 95/98/Me/NT4.0/2000/XP and close all other applications.

- The following dialogue box will appear. Click **[Cancel]** to close it.



- You must be logged in as an administrator in Windows NT4.0/2000/XP.

- 3 Insert the included CD-ROM into your CD-ROM drive.
 - The **[Choose Setup Language]** dialogue box will appear. Select the desired language that you want to use with this software from the drop-down list. Click **[OK]**. The installation will automatically start.
 - If the **[Choose Setup Language]** dialogue box does not appear: The installation will automatically start.
 - If the installation does not start automatically: Click **[Start]**. Choose **[Run...]**. Type “d:\setup” (where “d:” is the drive letter of your CD-ROM drive). Click **[OK]**. (If you are not sure what the drive letter is for your CD-ROM drive, use Windows Explorer and look for the CD-ROM drive.)

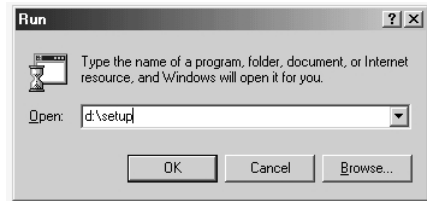

The installation will start.

- 4 Follow the instructions on the screen until all files have been installed.
 - Readiris OCR software can also be installed. For details about OCR software, see page 56.
 - If the fax machine is not connected to your computer, the **[Port Selection]** dialogue box will appear. Select the port number that you want to use. If the fax machine is connected to your computer, the port number will be automatically detected.

To uninstall the software

1. Click **[Start]**.
2. Point to **[Settings]**, then click **[Control Panel]**.
3. Double-click **[Add/Remove Programs]**.
4. Select **[Panasonic Multi-Function Station]** from the list.
5. Click **[Add/Remove...]** (Windows 95/98/Me/NT4.0) / **[Change/Remove...]** (Windows 2000/XP), then follow the instructions on the screen.

Important notice for USB cable users

- If you use a USB cable with Windows XP, the following message may appear:
“The software you are installing for this hardware has not passed Windows Logo testing to verify its compatibility with Windows XP”
You can continue the installation with no problem.

- The screens shown in these instructions are from Windows Me.
- The screens may differ slightly from those of the actual product.
- The screens are subject to change for improvement without notice.

Setup (PC)

Activating Multi-Function Station software

- 1 Click **[Start]** in Windows.
- 2 Point to **[Programs]**, point to **[Panasonic Multi-Function Station]** and click **[Launcher]**.
 - **[Launcher]** will appear.

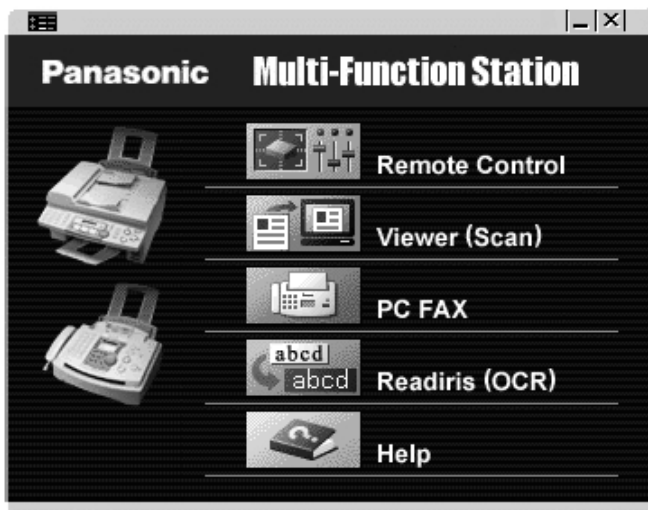

Remote Control (p. 57)

- To store, edit or erase entries in directories.
- To program the basic and advanced features.
- To view or erase items in the journal report or Caller ID list.
- To store caller information into directories.

Viewer (Scan) (p. 56)

- To display the images which support TIFF, JPEG, PCX, DCX and BMP formats.
- To create an image file by scanning the document set in the fax machine.

PC FAX (p. 58)

- To transmit a document created on the PC.
- To display a document received on the PC.

Readiris (OCR) (p. 56)

- To convert an image into editable text data.

Help

- For detailed instructions on Multi-Function Station.

Note:

- Each time Windows is started, the status monitor appears in the task tray on your computer. If there are any problems with the fax machine, it will display an error message on your computer.
- You can confirm if the fax machine is connected to your computer on the status monitor.
- Multi-function features (printing, scanning, etc.) may not function properly in the following situations:
 - When the fax machine is connected to a PC that was custom-built by the user.
 - When the fax machine is connected to the PC via a PCI card or other expansion card.
 - When the fax machine is connected to another piece of hardware (such as a USB hub or interface adapter) and not connected directly to the PC.

Using the fax machine as a printer

You can print not only on plain paper but also on special media (transparencies/labels/envelopes).

Printing from Windows applications

You can print a file created in a Windows application.

For example, to print from Microsoft Word, proceed as follows.

1 Open the document you want to print.

2 Select **[Print...]** from the **[File]** menu.

- The **[Print]** dialogue box will appear. For details about the **[Print]** dialogue box, click **[?]**, then click the desired item.

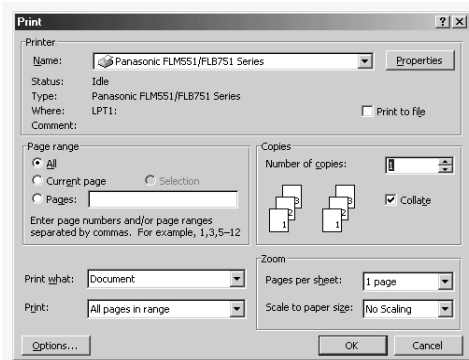

3 Select **[Panasonic FLM551/FLB751 Series]** as the active printer from the drop-down list.

- If you want to change the printer setting, click **[Properties]** (see right).

4 Set the printing information.

5 Click **[OK]**.

- The fax machine will start printing.

Note:

- To load paper, see page 19.
- For details about the paper specifications, see pages 54, 55 and 82.

Setting the printer properties

You can change the printer setting in the **[Paper]** tab in step 3.

We recommend that you test paper (especially special sizes and types of paper) on the fax machine before purchasing large quantities.

• Paper size

A4:	210 mm x 297 mm
Letter:	216 mm x 279 mm
Legal:	216 mm x 356 mm
COM10:	105 mm x 241 mm
DL:	110 mm x 220 mm

• Orientation

Portrait:	To print in tall format.
Landscape:	To print in wide format.

• Media choice

Plain Paper (Standard): For standard printing. The toner save feature will be off.

Plain Paper (Toner Save ON): To save on toner consumption. The print quality may be lowered.

Transparency: To print on a transparency.

Printing (PC)

Transparencies

Use transparencies designed for laser printing.

- **Load transparency sheets one page at a time for printing. Print side must face down.**
- **Remove each transparency after printing and place it on a flat surface to cool and to prevent it from curling.**
- Close the paper stacker extender (p. 18) while printing to prevent transparencies from curling.
- Do not re-use transparencies that have already been fed through the fax machine. This includes transparencies that have been fed through and ejected without being printed on.
- Some types of transparencies have instructions recommending which side to print on. If the print quality is poor, try printing on the other side.

Labels

Use labels designed for laser printing.

- **Load label sheets one page at a time for printing. Print side must face down.**
- **Remove each label after printing.**
- Do not use the following types of labels:
 - Labels that are wrinkled, damaged or separated from the backing sheet.
 - Any sheet of labels that has spaces in it where some of the labels have been removed.
 - Labels that do not completely cover the backing sheet (see below).

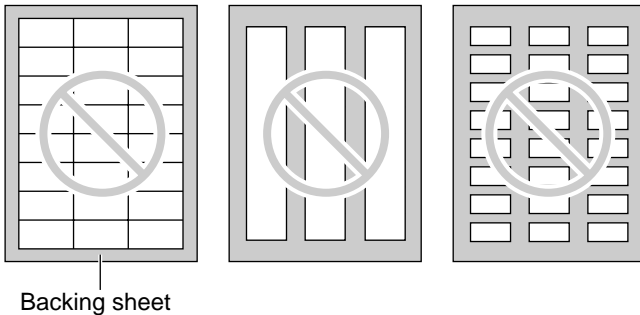

Envelopes

Use envelopes designed for laser printing. We recommend the following:

- High quality envelopes of 90 g/m² paper,
- Envelopes that have thin, sharply creased leading edges, and
- Envelopes that have diagonal seams as shown. (right)

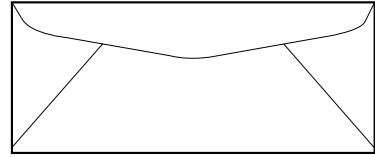

- **You can load up to 10 envelopes of 90 g/m² paper at a time for printing. Print side must face down.**
- **Remove each envelope after printing.**
- Wrinkles may occur in some cases, even if high quality envelopes are used.
- Avoid printing in high humidity, above 70% relative humidity (RH). High humidity may cause the envelope to curl, pick up excess toner or seal the envelope.
- Avoid printing below 10 °C with less than 30% RH, or it may cause light printing.
- Store envelopes away from moisture and humidity, where they can lay flat and their edges will not be bent or damaged. The humidity should not exceed 70% RH.

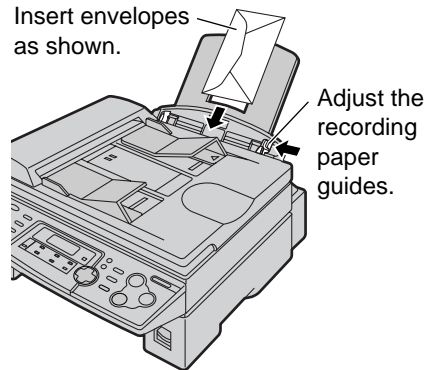

Do not use envelopes with any of the following characteristics (using these may result in paper jams):

- Irregularly shaped envelopes
- Envelopes with curls, wrinkles, nicks, twists, dog-ears or other damage
- Envelopes with side seam construction
- Highly textured envelopes, or envelopes with extremely shiny surfaces
- Envelopes that seal by removing a peel-off strip
- Envelopes with more than one flap to be sealed
- Self-adhesive envelopes
- Envelopes that are baggy or not sharply creased
- Embossed envelopes
- Envelopes that have previously been printed on
- Envelopes that include cotton and/or fibre material

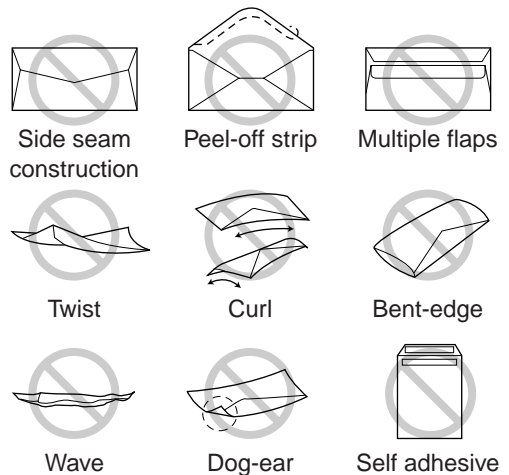

Do not attempt to print on any of the following types of envelopes (these may cause damage to the fax machine):

- Envelopes with clasps, snaps or tie strings
- Envelopes with transparent windows
- Envelopes that use encapsulated types of adhesive that do not require moistening but rely on pressure to seal them

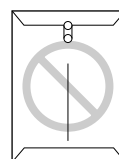

Clasp



Transparent window

Using the fax machine as a scanner

Using Multi-Function Viewer

- 1 Using the auto document feeder**
Insert the document (up to 15 pages)
FACE DOWN in the fax machine.

Using the scanner glass

Place the document FACE DOWN on the scanner glass of the fax machine.

- 2** Press **[SCAN]**.
 - The **[Panasonic FLM551/FLB751 Series]** dialogue box will appear.
 - If the dialogue box does not appear, check the connection of the PC and the fax machine.
- 3** If necessary, change the setting of **[Scan Configuration]**, **[Custom Scan Settings]**, **[Contrast]** and **[Paper]**.

- 4** Click **[Scan]**.
 - The scanned image will be displayed in the **[Multi-Function Viewer]** window after scanning.
 - To save the scanned image, select **[Save]** from the **[File]** menu.
 - To cancel scanning while the document is being scanned, click **[Cancel]**.

Note:

- You can display the images which support TIFF, JPEG, PCX, DCX and BMP formats.
- You can move, copy and delete a file or page.

Readiris OCR software

With OCR software, you can convert an image into text data that can be edited with word processor software. Readiris OCR software can be installed when installing Multi-Function Station software. To use this software, click the **[OCR]** icon in the **[Multi-Function Viewer]** window or select **[Readiris (OCR)]** from **[Launcher]**. For detailed instructions about OCR, select **[Help]**.

Using other applications

Multi-Function Station includes a TWAIN compliant scanner driver. You can also scan using other applications that support TWAIN scanning.

For example, to scan from Imaging for Windows, proceed as follows:

- 1 Using the auto document feeder**
Insert the document (up to 15 pages)
FACE DOWN in the fax machine.

Using the scanner glass

Place the document FACE DOWN on the scanner glass of the fax machine.

- 2** Start Imaging for Windows.
- 3** Select **[Select Scanner...]** (Windows 95/98/Me/NT4.0) / **[Select Device...]** (Windows 2000) from the **[File]** menu, then select the **[Panasonic FLM551/FLB751 Series]** in the dialogue box.

- 4** Select **[Scan New...]** (Windows 95/98/Me/NT4.0) / **[Acquire Image...]** (Windows 2000) from the **[File]** menu, or click the **[Scan New]** icon in the tool bar.
 - The **[Panasonic FLM551/FLB751 Series]** dialogue box will appear.
 - If the dialogue box will not appear, check the connection of the PC and the fax machine.

- 5** If necessary, change the setting of **[Scan Configuration]**, **[Custom Scan Settings]**, **[Contrast]** and **[Paper]**.

- 6** Click **[Scan]**.
 - The scanned image will be displayed in the **[Imaging for Windows]** window after scanning.
 - To cancel scanning while the document is being scanned, click **[Cancel]**.

Operating the fax machine from your computer

You can easily operate the following functions from your computer.

- Storing, editing or erasing entries in directories (p. 26–28, 38–40)
- Programming the basic and advanced features (p. 61–65)
- Viewing or erasing items in the journal report (p. 35)
- Storing the journal report as PC file
- Viewing or erasing items in the Caller ID list (p. 30)
- Storing caller information into directories (p. 33)
- Storing the Caller ID list as PC file

- 1 Start Multi-Function Station.
- 2 Select **[Remote Control]**.
 - The **[Multi-Function Remote Control]** window will appear.

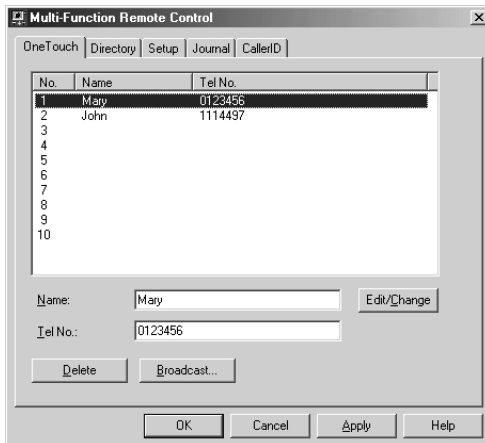

- 3 Select the desired tab.
 - The latest data in the fax machine will be displayed.
- 4 Perform the desired operation.
 - For details about each function, click **[Help]**.
 - To stop the operation, click **[Cancel]**.
- 5 Click **[OK]**.
 - The new data will be transferred to the fax machine and the window will close.
 - You can also click **[Apply]** to continue the next operation without closing the window.

Note:

- Some of the basic and advanced features cannot be programmed from your computer.

Fax sending/receiving using Multi-Function Station software

Sending a PC document as a fax message from your PC

You can access the fax function from a Windows application using Multi-Function Station software.

For example, to send a document created from Microsoft Word, proceed as follows:

- 1 Open the document you want to send.
- 2 Select **[Print...]** from the **[File]** menu.
 - The **[Print]** dialogue box will appear.

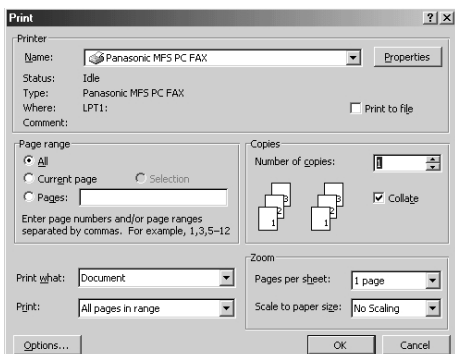

- 3 Select **[Panasonic MFS PC FAX]** as the active printer.
- 4 Click **[OK]**.
 - The **[Send a fax]** dialogue box will appear.

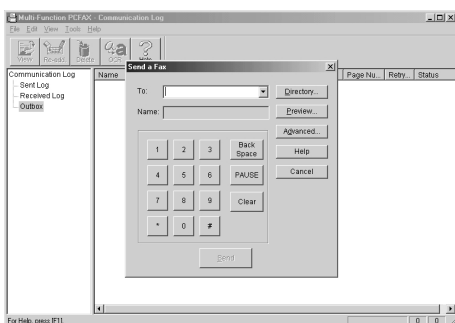

- 5 Enter the fax number using the keypad display or the directory.

- 6 Click **[Send]**.
 - The document will be sent through the fax machine from your PC.

Note:

- To stop transmission, press **[STOP]** on the fax machine.
- If the document exceeds the memory capacity of your fax machine, sending will be cancelled.

Receiving a fax into your PC

You can receive a fax on your computer. The received fax document is saved as an image file (TIFF-G4 format).

1 Start Multi-Function Station.

2 Select **[PC FAX]**.

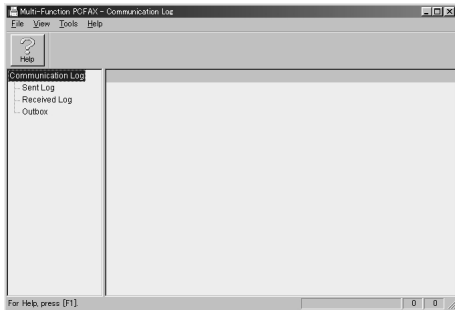

3 When a fax call is received, your PC will receive a document through the fax machine.

Note:

- You can view, print or transfer the received document using your PC.
- If Multi-Function PC FAX has not started, the received document will be printed on the fax machine.

Viewing a received document

1. Select **[PC FAX]**.
2. Select **[Received Log]** in **[Communication Log]**.

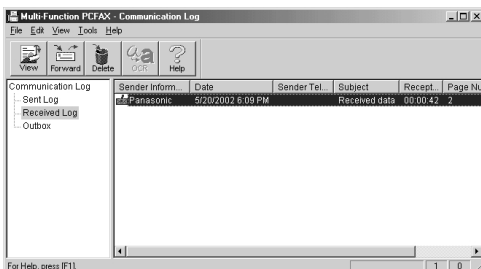

3. Click the item you want to view.
4. Click **[File]** in the menu bar, then select **[View]**, or click **[View]** in the toolbar.
 - The received fax will be displayed.

If you do not want to be disturbed by incoming faxes while using the PC

You can change the setting to receive a fax directly on the fax machine.

1. Click **[Tools]** in the menu bar, then click **[Function Setup]**.
 - The **[Function Setup]** dialogue box will appear.

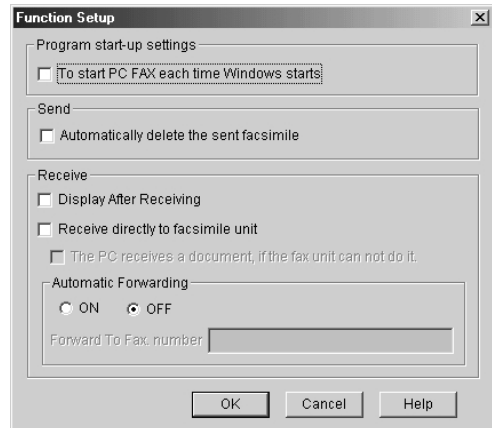

2. Click **[Receive directly to facsimile unit]**.
3. Click **[OK]**.

If the fax machine's memory stores a received fax document

You can load the document into your PC.

1. Select **[PC FAX]**.
2. Select **[Received Log]** in **[Communication Log]**.
3. Click **[File]** in the menu bar, then click **[Receive a fax]**.

Features Summary

Programming

The unit provides various programming features. Program the desired settings by referring to the programming tables (p. 61–65).

General programming method

1 Press **MENU**.

Display:

SYSTEM SET UP PRESS NAVI. [◀ ▶]

2 Select the feature you wish to program.
For basic features (p. 61, 62):

Press **◀** or **▶** until the desired feature is displayed.

For advanced features (p. 63–65):

Press **◀** or **▶** until the following is displayed:

ADVANCED MODE PRESS SET

then press **SET** and press **◀** or **▶** until the desired feature is displayed.

- The current setting of the feature will be displayed.

3 Press **+** or **-** until the desired setting is displayed.

- This step may be slightly different depending on the feature.

4 Press **SET**.

- The setting you selected is set, and the next feature will be displayed.

5 To exit programming, press **MENU**.

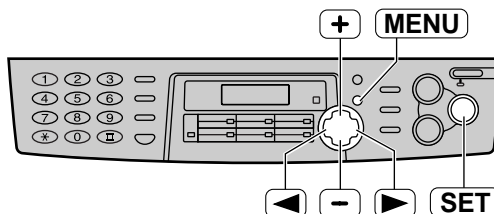

Programming by entering the program code number directly

You can select a feature by directly entering the program code (# and 2-digit number) instead of using **◀** or **▶** in step 2.

1. Press **MENU**.
2. Press **#** and the 2-digit code number.
3. Follow steps 3 to 5 above.

- See programming tables for code numbers (p. 61–65).

To cancel programming

Press **MENU** to exit the program.

Basic features

Programming table

Code	Feature & Display	Settings	How the unit operates
#01	Setting the date and time <div style="border: 1px solid black; padding: 2px; width: fit-content;"> SET DATE & TIME PRESS SET </div>	/	See page 21 for details.
#02	Setting your logo <div style="border: 1px solid black; padding: 2px; width: fit-content;"> YOUR LOGO PRESS SET </div>	(Up to 30 characters)	See page 22 for details.
#03	Setting your facsimile telephone number <div style="border: 1px solid black; padding: 2px; width: fit-content;"> YOUR FAX NO. PRESS SET </div>	(Up to 20 digits)	See page 24 for details.
#04	Printing the sending report <div style="border: 1px solid black; padding: 2px; width: fit-content;"> SENDING REPORT =ERROR [±] </div> To print and check the sending report for fax transmission results (p. 35).	ERROR	"ERROR": The sending report will be printed only when fax transmission fails. "ON": The sending report will be printed out after every transmission.
		ON	
		OFF	
#06	Changing the ring setting in FAX ONLY mode <div style="border: 1px solid black; padding: 2px; width: fit-content;"> FAX RING COUNT RINGS=2 [±] </div> To change the number of rings before the unit answers a call in FAX ONLY mode.	1, 2 , 3, 4, 5, 6, 7, 8, 9	If you are using the unit with an answering machine, set to more than 4 (p. 46).
#12	Securing the remote operation for the answering machine <div style="border: 1px solid black; padding: 2px; width: fit-content;"> REMOTE TAM ACT. =OFF [±] </div> If you are using the unit with an answering machine, activate this feature, and set the remote activation ID to secure the remote operation for the answering machine.	ON / ID= 11	To select "ON" and enter ID: 1. Press MENU . 2. Press ◀ or ▶ and select this feature. 3. Press + or - to select "ON". 4. Press SET . 5. Enter your ID from 1 to 5 digits, using 0-9, * and #. 6. Press SET . 7. Press MENU .
		OFF	

(The default setting is in bold type.)

Features Summary

Basic features (cont.)

How to set menu options

1. Press **MENU**.
2. Press **◀** or **▶** until the desired feature is displayed.
3. Press **+** or **-** until the desired setting is displayed.
4. Press **SET**.
5. Press **MENU**.

Note:

- Step 3 may be slightly different depending on the feature.
- See page 60 for more details.

Programming table (cont.)

Code	Feature & Display	Settings	How the unit operates
#15	Selecting the cable type to connect to the PC <div style="border: 1px solid black; padding: 2px; width: fit-content;"> PC INTERFACE =PARALLEL [±] </div> If you use Multi-Function Station, change the setting depending on the cable connected to your computer.	PARALLEL	"PARALLEL": IEEE1284 compliant parallel cable "USB": USB cable • When the setting is changed, the fax machine adjusts to new setting. Please wait.
		USB	
#16	Setting the recording paper size <div style="border: 1px solid black; padding: 2px; width: fit-content;"> PAPER SIZE =A4 [±] </div>	LETTER	"LETTER": Letter size paper "A4": A4 size paper "LEGAL": Legal size paper
		A4	
		LEGAL	
#17	Setting the ringer pattern <div style="border: 1px solid black; padding: 2px; width: fit-content;"> RINGER PATTERN =A [±] </div>	A	You can select the ringer pattern. The selected ringer pattern will sound during setting.
		B	
		C	

(The default setting is in bold type.)

Advanced features

How to set menu options

1. Press **MENU**.
2. Press **◀** or **▶** until the following is displayed:
3. Press **+** or **-** until the desired setting is displayed.
4. Press **SET**.
5. Press **MENU**.

ADVANCED MODE
PRESS SET

then press **SET** and press **◀** or **▶** until the desired feature is displayed.

Note:

- Step 3 may be slightly different depending on the feature.
- See page 60 for more details.

Programming table

Code	Feature & Display	Settings	How the unit operates
#22	Setting the journal report to print automatically <div style="border: 1px solid black; padding: 2px; margin: 5px 0;"> AUTO JOURNAL =ON [±] </div>	ON	"ON": The unit will print the journal report automatically after every 30 new fax communications (p. 35).
		OFF	
#23	Sending document overseas <div style="border: 1px solid black; padding: 2px; margin: 5px 0;"> OVERSEAS MODE =OFF [±] </div> If you have difficulty sending an overseas fax, activate this feature before starting transmission. This feature makes sending documents easier as the transmission speed is slowed down.	ON	After transmission, this feature will turn off automatically. <ul style="list-style-type: none"> • This feature is not available for broadcast transmission. • The calling charge may be higher.
		OFF	
#25	Sending a fax at a specific time <div style="border: 1px solid black; padding: 2px; margin: 5px 0;"> DELAYED SEND =OFF [±] </div> This feature allows you to take advantage of low-cost calling hours offered by your telephone company. <ul style="list-style-type: none"> • The setting can be reserved to take place up to 24 hours in advance. 	ON / fax no. / hh:mm	To send a document: <ol style="list-style-type: none"> 1. Insert the document into the auto document feeder. 2. Follow steps 1 and 2 above. 3. Press + or - to select "ON". 4. Press SET. 5. Enter the fax number. 6. Press SET. 7. Enter the transmission start time. Press * to select "AM" or "PM". 8. Press SET. 9. Press MENU. <ul style="list-style-type: none"> • To cancel after programming, press STOP then SET.
		OFF	

(The default setting is in bold type.)

Features Summary

Advanced features (cont.)

How to set menu options

1. Press **MENU**.
2. Press **◀** or **▶** until the following is displayed:
3. Press **+** or **-** until the desired setting is displayed.
4. Press **SET**.
5. Press **MENU**.

ADVANCED MODE
PRESS SET

then press **SET** and press **◀** or **▶** until the desired feature is displayed.

Note:

- Step 3 may be slightly different depending on the feature.
- See page 60 for more details.

Programming table (cont.)

Code	Feature & Display	Settings	How the unit operates
#26	Setting the Caller ID list to print automatically <div style="border: 1px solid black; padding: 2px; margin-top: 5px;"> AUTO CALL. LIST =ON [±] </div>	ON	"ON": The unit will print the Caller ID list automatically after every 30 new calls (p. 30).
		OFF	
#37	Receiving other size documents <div style="border: 1px solid black; padding: 2px; margin-top: 5px;"> AUTO REDUCTION =ON [±] </div> To receive a fax document that is longer than your recording paper.	ON	"ON": The unit will fit a received document onto your recording paper.
		OFF	"OFF": The unit will print the original size.
#39	Changing the display contrast <div style="border: 1px solid black; padding: 2px; margin-top: 5px;"> LCD CONTRAST =NORMAL [±] </div>	NORMAL	"NORMAL": For normal contrast "DARKER": Used when the display contrast is too light.
		DARKER	
#41	Changing the fax activation code <div style="border: 1px solid black; padding: 2px; margin-top: 5px;"> FAX ACTIVATION =ON [±] </div> If you use an extension telephone and wish to use it to receive a fax, activate this feature, and enter the code (p. 47). • This code is also used to receive a voice message and a fax in the same call (p. 47).	ON / CODE=*#9	<ol style="list-style-type: none"> 1. Follow steps 1 and 2 above. 2. Press + or - to select "ON". 3. Press SET. 4. Enter your code from 2 to 4 digits, using 0–9, # and *. 5. Press SET. 6. Press MENU. • Do not enter "0000".
		OFF	

(The default setting is in bold type.)

Features Summary

Code	Feature & Display	Settings	How the unit operates
#44	Setting the memory reception alert <div style="border: 1px solid black; padding: 2px; margin: 5px 0;">RECEIVE ALERT =ON [±]</div> To alert you with a beeping sound when a document which has been received is stored into memory due to some existing problem.	ON	If you are alerted by a slow beeping sound, clear the printing problem and make sure the unit is supplied with enough paper to print the stored document. The beeps will stop.
		OFF	
#68	Setting the Error Correction Mode (ECM) <div style="border: 1px solid black; padding: 2px; margin: 5px 0;">ECM SELECTION =ON [±]</div> To send a fax even if there is static interference on the telephone line.	ON	This feature is available when the transmitting/receiving stations are ECM compatible.
		OFF	
#76	Setting the connecting tone <div style="border: 1px solid black; padding: 2px; margin: 5px 0;">CONNECTING TONE =ON [±]</div> If you often have trouble when sending a fax, this feature allows you to hear connecting tones: fax tone, ring back tone and busy tone.	ON	You can confirm the status of the other party's machine. <ul style="list-style-type: none"> ● If the ring back tone continues, the other party's machine may not be a facsimile or may have run out of paper. Check with the other party. ● The connecting tone volume cannot be adjusted.
		OFF	
#79	Saving on toner consumption <div style="border: 1px solid black; padding: 2px; margin: 5px 0;">TONER SAVE =OFF [±]</div>	ON	"ON": The toner cartridge will last longer. <ul style="list-style-type: none"> ● This feature may lower the print quality.
		OFF	
#80	Resetting advanced features to their default settings <div style="border: 1px solid black; padding: 2px; margin: 5px 0;">SET DEFAULT RESET=NO [±]</div>	YES	<ol style="list-style-type: none"> 1. Follow steps 1 and 2 on page 64. 2. Press + or - to select "YES". 3. Press SET. 4. Press SET again. 5. Press MENU.
		NO	

(The default setting is in bold type.)

Error Messages

Reports

If your unit cannot send a fax, check the following:

- the number you dialled is correct,
- the other party's machine is a facsimile.

If the problem remains, correct it by following the communication message printed on the sending and journal reports (p. 35).

COMMUNICATION ERROR

(CODE: 40–42, 46–72, FF)

- A transmission or reception error occurred. Try again or check with the other party.

COMMUNICATION ERROR

(CODE: 43, 44)

- A line problem occurred. Connect the telephone line cord to a different socket and try again.
- An overseas transmission error occurred. Try using the overseas mode of feature #23 (p. 63).

DOCUMENT JAMMED

- The document is jammed. Remove the jammed document (p. 77).

ERROR-NOT YOUR UNIT

(CODE: 54, 59, 70)

- A transmission or reception error occurred because of a problem with the other party's fax machine. Check with the other party.

MEMORY FULL

- The document was not received as a result of the memory being full.

NO DOCUMENT

- The document was not fed into the unit properly. Reinsert the document and try again.

OTHER FAX NOT RESPONDING

- The other party's fax machine is busy or has run out of recording paper. Try again.
- The document was not fed properly. Reinsert the document and try again.
- The other party's fax machine rings too many times. Send the fax manually (p. 34, 35).
- The other party's machine is not a facsimile. Check with the other party.
- The number you dialled is not in service.

PRESSED THE STOP KEY

- **STOP** was pressed and fax communication was cancelled.

THE COVER WAS OPENED

- The printer cover was opened. Close it and try again.

OK

- Fax communication was successful.

Display

If the unit detects a problem, one or more of the following messages will appear on the display.

Display message	Cause & solution
CALL SERVICE	<ul style="list-style-type: none"> There is something wrong with the unit. Contact our service personnel.
CARRIAGE ERROR	<ul style="list-style-type: none"> The shipping lock is locked. Unlock the shipping lock (p. 15). If the display messages still remain after unlocking, there is something wrong with the carriage sensor. Contact our service personnel.
RELEASE SHIPPING LOCK	
CHANGE DRUM	<ul style="list-style-type: none"> There is something wrong with the drum unit. Replace the drum unit and the toner cartridge (p. 73).
CHECK ADF CABLE	<ul style="list-style-type: none"> The ADF cable is not connected correctly. Check the connection (p. 15).
CHECK DOCUMENT	<ul style="list-style-type: none"> The document was not fed into the unit properly. Reinsert the document. If misfeeding occurs frequently, clean the document feeder rollers (p. 79) and try again.
CHECK DRUM	<ul style="list-style-type: none"> The drum unit is not inserted properly. Reinsert it correctly (p. 16).
CHECK MEMORY	<ul style="list-style-type: none"> The memory (telephone numbers, parameters, etc.) has been erased. Re-program.
CLOSE ADF COVER	<ul style="list-style-type: none"> The ADF cover is open. Close it.
COVER OPEN	<ul style="list-style-type: none"> The printer cover is open. Close it.
DATA IN MEMORY	<ul style="list-style-type: none"> You tried to change the cable type setting (feature #15 on page 62), while the fax machine has a document in memory. Finish sending faxes, print out the document in memory (p. 44) or cancel the delayed transmission (feature #25 on page 63) and try again.
DIRECTORY FULL	<ul style="list-style-type: none"> There is no space to store new entries in navigator directory. Erase unnecessary entries (p. 28).
FAILED PICK UP	<ul style="list-style-type: none"> Recording paper was not fed into the unit properly. Reinsert the recording paper (p. 76).
FAX IN MEMORY	<ul style="list-style-type: none"> The unit has a document in memory. See the other displayed message instructions to print out the document.
FAX MEMORY FULL	<ul style="list-style-type: none"> The memory is full of received documents due to a lack of recording paper or a recording paper jam. Install paper (p.19) or clear the jammed paper (p. 75). When performing memory transmission, the document being stored exceeds the memory capacity of the unit. Transmit the entire document manually.

Error Messages

Display message	Cause & solution
LINE IN USE	<ul style="list-style-type: none"> You cannot change the cable type setting (feature #15 on page 62) while using the handset or the monitor. Hang up and try again.
MEMORY FULL	<ul style="list-style-type: none"> When making a copy, the document being stored exceeds the memory capacity of the unit. Press STOP to clear the message. Divide the document into sections.
MODEM ERROR	<ul style="list-style-type: none"> There is something wrong with the modem circuit. Contact our service personnel.
NO FAX REPLY	<ul style="list-style-type: none"> The other party's fax machine is busy or has run out of recording paper. Try again.
OUT OF PAPER	<ul style="list-style-type: none"> Recording paper is not installed or the unit has run out of paper. Install paper (p. 19). Recording paper is not fed into the unit properly. Reinstall paper (p. 19).
PAPER JAMMED	<ul style="list-style-type: none"> A recording paper jam occurred. Clear the jammed paper (p. 75).
PC FAIL OR BUSY	<ul style="list-style-type: none"> The cable or the PC power cord is not connected correctly. Check the connections (p. 50). The software is not running on the PC. Restart the software and try again.
PLEASE WAIT	<ul style="list-style-type: none"> The unit is warming up. Wait for a while.
REDIAL TIME OUT	<ul style="list-style-type: none"> The other party's fax machine is busy or has run out of recording paper. Try again.
REMOVE DOCUMENT	<ul style="list-style-type: none"> The document is jammed. Remove the jammed document (p. 77). Attempted to transmit a document longer than 600 mm. Press STOP to remove the document. Divide the document into two or more sheets and try again.
TONER EMPTY	<ul style="list-style-type: none"> The toner cartridge is empty. Replace the toner cartridge (p. 73).
TONER LOW	<ul style="list-style-type: none"> The remaining toner is low. Replace the toner cartridge as soon as possible (p. 73). We recommend you replace the drum unit every third time you replace the toner cartridge. To check the drum life and quality, please print the printer test list (p. 80).
TRANSMIT ERROR	<ul style="list-style-type: none"> A transmission error occurred. Try again.
WRONG PAPER	<ul style="list-style-type: none"> The fax message was printed on paper which is shorter than A4 size paper. Use the appropriate size paper (p. 19).

When a function does not work, check here before requesting help

General

I cannot make and receive calls.

- The mains lead or telephone line cord is not connected. Check the connections (p. 20).
- If you used a splitter to connect the unit, remove the splitter and connect the unit to the wall socket directly. If the unit operates properly, check the splitter.

The unit does not work.

- Disconnect the unit from the telephone line and connect the line to a known working telephone. If the working telephone operates properly, contact our service personnel to have the unit repaired. If the working telephone does not operate properly, contact your telephone company.

The unit does not ring.

- The ringer volume is set to off. Adjust it (p. 25).

The other party complains they only hear a fax tone and cannot talk.

- FAX ONLY mode is set. Tell the other party the number is only used for faxes.
- Change to TEL mode (p. 44).

The **REDIAL/PAUSE** button does not function properly.

- If this button is pressed during dialling, a pause will be inserted. If pressed immediately after a dial tone is obtained, the last number dialled will be redialled.

During programming, I cannot enter the code or ID number.

- All or part of the numbers are the same. Change the number of features #12 (p. 61) and #41 (p. 64).

The unit beeps.

- Recording paper has run out. Press **STOP** to stop the beeps and install paper.

Fax – sending

I cannot send documents.

- The telephone line cord is connected to the EXT socket on the unit. Connect to the LINE socket (p. 20).
- The other party's fax machine is busy or has run out of recording paper. Try again.
- The other party's machine is not a facsimile. Check with the other party.
- The other party's fax machine rings too many times. Send the fax manually (p. 34, 35).

The other party complains that letters on their received document are distorted or not clear.

- If your line has special telephone services such as Call Waiting, the service may have been activated during fax transmission. Connect the unit to a line that does not have these services.
- The extension telephone on the same line is off the hook. Hang up the extension telephone and try again.
- Try copying the document. If the copied image is clear, there may be something wrong with the other party's machine.

The other party complains that dirty patterns or black lines appear on their received document.

- The white plate or scanner glass is dirty. Clean them (p. 77).

I cannot send a fax overseas.

- Use the overseas transmission mode of feature #23 (p. 63).
- Add two pauses at the end of the telephone number or dial manually.

Fax – receiving

I cannot receive documents.

- The telephone line cord is connected to the EXT socket on the unit. Connect to the LINE socket (p. 20).

I cannot receive documents automatically.

- The receiving mode is set to TEL mode. Set to FAX ONLY mode (p. 45).
- The time taken to answer the call is too long. Decrease the number of rings of feature #06 (p. 61).

The display shows the following, but faxes are not received.

CONNECTING.....

- The incoming call is not a fax. Change the receiving mode to TEL mode (p. 44).

A blank sheet is ejected.

- The other party placed the document in their fax machine the wrong way. Check with the other party.

A white line or a dirty pattern appears on your recording paper.

- The white plate, scanner glass or lower glass are dirty. Clean them (p. 77–79).

The printing quality is poor.

- The other party sent a faint document. Ask them to send a clearer copy of the document.
- Some paper has instructions recommending which side to print on. Try turning the paper over.
- You may have used paper with a cotton and/or fibre content that is over 20%, such as letterhead or resume paper.
- The remaining toner is low. Replace the toner cartridge (p. 73).
- We recommend you replace the drum unit every third time you replace the toner cartridge (p. 73). To check the drum life and quality, please print the printer test list (p. 80).
- The toner save mode of feature #79 is on (p. 65).

(continued)

The other party complains that they cannot send a document.

- The memory is full of received documents due to a lack of recording paper or a recording paper jam. Install paper (p. 19) or clear the jammed paper (p. 75).

Receiving mode

I cannot select the desired receiving mode.

- If you want to set FAX ONLY mode:
 - press **AUTO ANSWER** to turn on the FAX ON light.

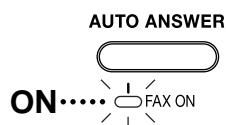

- If you want to set TEL mode:
 - press **AUTO ANSWER** to turn off the FAX ON light.

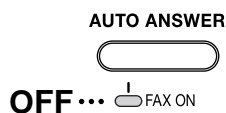

The other party complains that they cannot send a document.

- The unit is not set to FAX ONLY mode. Press **AUTO ANSWER** to turn on the FAX ON light.

Copying

The unit does not make a copy.

- You cannot make a copy during programming. Make the copy after programming or stop programming.

A black line, a white line or a dirty pattern appears on the copied document.

- The white plate, scanner glass or lower glass are dirty. Clean them (p. 77–79).

(continued)

Copying (cont.)

The printing quality is poor.

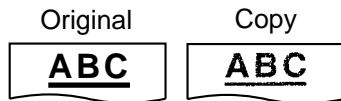

- Some paper has instructions recommending which side to print on. Try turning the paper over.
- You may have used paper with a cotton and/or fibre content that is over 20%, such as letterhead or resume paper.
- The remaining toner is low. Replace the toner cartridge (p. 73).
- We recommend you replace the drum unit every third time you replace the toner cartridge (p. 73). To check the drum life and quality, please print the printer test list (p. 80).
- The toner save mode of feature #79 is on (p. 65).
- When you make a copy from transparencies, be sure to use the scanner glass. Place a blank sheet of paper on the top of the transparency, and leave the document cover open during copying (p. 48).

Using an answering machine

I cannot receive documents automatically.

- Your greeting message on the answering machine is too long. Shorten the message (record a message up to 10 seconds long).
- The answering machine rings too many times. Set to 1 or 2 rings.

I cannot receive voice messages.

- Check if the answering machine is turned on and connected to the fax machine properly (p. 46).
- Set the number of rings on the answering machine to 1 or 2.

I cannot retrieve recorded voice messages on the answering machine from a remote location.

- You did not program your remote access code into your fax machine correctly. Program the same code that is programmed on the answering machine on the fax machine with feature #12 (p. 61).

(continued)

I pressed the remote access code to access the answering machine remotely, but the line was disconnected.

- The code may include “#” which is used for certain features provided by telephone companies. Change the code on the answering machine to another number which does not include “#”. Also change the code of the fax machine with feature #12 (p. 61).

Callers complain that they cannot send a document.

- Your answering machine has run out of recording tape. Rewind the tape to record messages.
- You set the answering machine to only give a greeting message.

Multi-Function Station

I cannot open a TIFF file.

- You must change the compression format of the file.

Example: To convert an image using Imaging for Windows.

1. Click **[Start]**, point to **[Programs]** — **[Accessories]**, then click **[Imaging]**.
2. Open the TIFF file that you cannot open in **[Multi-Function Viewer]**.
3. Select **[Properties]** from the **[Page]** menu.
 - The **[Page Properties]** dialogue box will appear.
4. Click the **[Compression]** tab, then select **[CCITT Group 3 (1d) Modified Huffman]** from the drop-down list.
5. Click **[OK]**.
 - The compression format of the file is now changed.

[Launcher] disappears.

- Look in the tool bar. If you do not find the **[Launcher]** icon, it is closed. If you do find the icon, it is just minimized. Click the icon in the tool bar.

(continued)

Multi-Function Station (cont.)

I cannot recognize the last part of an entry in the list of the [One Touch], [Directory], [Journal] or [Caller ID].

- Put the cursor on the line between the buttons. The cursor changes shape and you can expand the area by dragging or double-clicking.

When I exit Multi-Function Station, the [Multi-Function Viewer] window does not close.

- The [Multi-Function Viewer] window can be operated separately. Click the [X] button to close the window.

I cannot scan.

- When scanning at a high resolution, a large amount of available memory is required. If your PC warns of insufficient memory, close all other applications and try again.
- The fax machine is in use. Try again later.
- There is not enough space on the hard disk. Delete unnecessary files and try again.
- Restart the PC, and try again.
- Check the connection of the PC and the fax machine (p. 50).
- You attempted to scan a document longer than the paper size which you set in the [Panasonic FLM551/FLB751 Series] dialogue box. Change the setting or divide the document into the appropriate paper size, and try again.

The document does not feed into the fax machine.

- Remove the document and reinsert it.

Even after clicking [Cancel], scanning continues.

- Please wait. It may take a while for the cancel request to be accepted.

(continued)

Multi-Function Station does not work properly.

- Click the [X] button to exit Multi-Function Station, and restart. If Multi-Function Station still does not close, restart the PC.
- If you connect the USB cable to USB hub, connect it to the USB port of your computer directly.
- Confirm the BIOS setting of your computer. For parallel connection, select ECP, Bi-directional or an equivalent parallel port mode. For USB connection, select USB port mode. Please refer to your PC operating instructions or consult the manufacturer.
- If you have any other multifunction softwares installed on your computer, uninstall them.

I want to replace the parallel cable with a USB cable and vice versa.

- You must change the printer properties.
 1. Replace the cables.
 2. Set the connection type (parallel or USB) by using the fax machine according to the cable type you use (feature #15 on page 62).
 3. Click [Start], point to [Settings], then click [Printers].
 4. Right-click [Panasonic FLM551/FLB751 Series] and click [Properties].
 - The [Panasonic FLM551/FLB751 Series Properties] dialogue box will appear.
 5. Click the [Details] (Windows 98/Me) / [Ports] (Windows 2000/XP) tab, select the connection type, then click [OK].
 - If Multi-Function Station does not work correctly, uninstall the software, then re-install it.

If a power failure occurs

- The unit will not function.
- The unit is not designed for making emergency telephone calls when the power fails. Alternative arrangements should be made for access to emergency services.
- Fax transmission and reception will be interrupted.
- If any fax documents are stored in the memory, they will be lost. When power is restored, a power down report will be printed out stating which contents in the memory have been erased.

Replacing the toner cartridge and the drum unit

When the display shows the following, replace the toner cartridge.

Display: TONER LOW or TONER EMPTY

We recommend you replace the drum unit every third time you replace the toner cartridge. To check the drum life and quality, please print the printer test list (p. 80).

To ensure that the unit operates properly, we recommend the use of **Panasonic toner cartridge (Model No. KX-FA76X/KX-FA79X) and drum unit (Model No. KX-FA78X)**. See page 11 for accessory information.

- **We cannot be responsible for any damage to the unit or degradation of print quality which may occur from the use of a non-Panasonic toner cartridge and drum unit.**

Caution:

- **The drum unit contains a photosensitive drum. Exposing it to light may damage the drum.**
Once you have opened the protection bag:
 - Do not expose the drum unit to light for more than 5 minutes.
 - Do not touch or scratch the green drum surface.
 - Do not place the drum unit near dust or dirt, or in a high humidity area.
 - Do not expose the drum unit to direct sunlight.
- **Do not unplug the fax machine to prevent loss of fax documents in memory.**
- **Do not leave the toner cartridge out of the protection bag for a long time. It will decrease the toner life.**
- **Do not pour any toner into the toner cartridge.**

- 1** Before opening the protection bag of the new toner cartridge, shake it vertically more than 5 times.

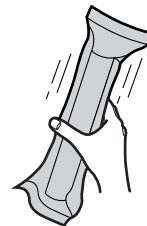

- 2** Remove the new toner cartridge from the protection bag. Peel off the seal from the toner cartridge.

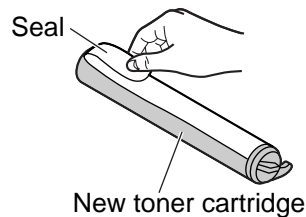

- 3** Press down the printer cover open button then open the printer cover.

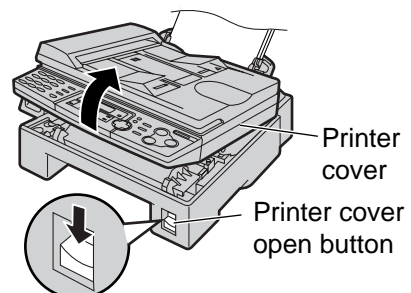

Replacement

- 4** Tap on the used toner cartridge several times to allow the remaining toner to fall into the drum unit. Remove the drum and toner unit by holding the two tabs.
- If you replace the toner cartridge and the drum unit at the same time, skip to step 7.

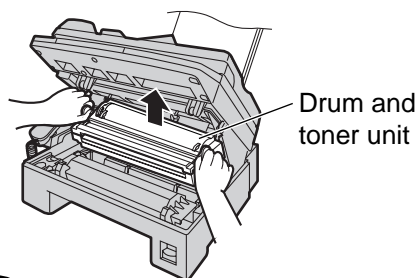

- 5** Turn the two levers on the used toner cartridge firmly.

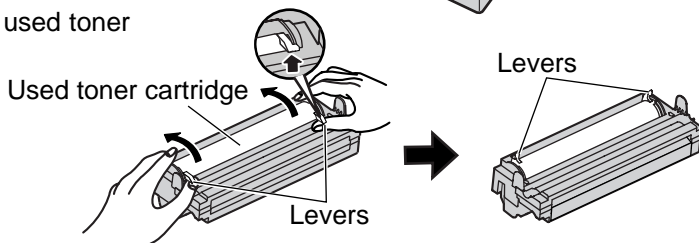

- 6** Pull up the right edge of the used toner cartridge (①). Remove the cartridge from the drum unit (②).
- The toner may stick to the cartridge and the drum unit. Be careful when handling. See page 4 for details.
 - Do not drop the toner on the green drum surface.
 - Put the used toner cartridge into the protection bag.

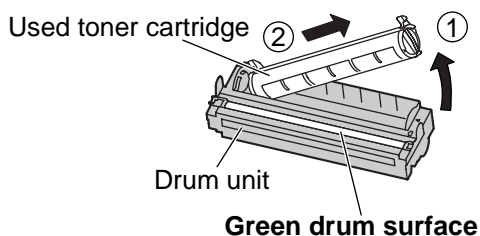

- 7** If you replace the drum unit at the same time, remove the new drum unit from the protection bag. Remove the protection bar from the drum unit.

With "Panasonic" face up on the toner cartridge, match the red arrows on the cartridge and the drum unit.

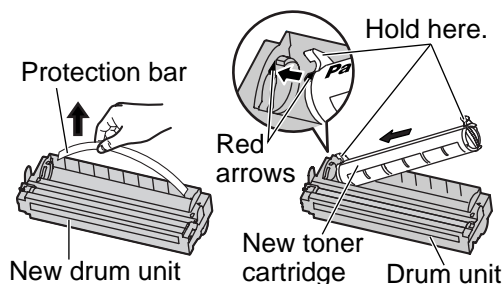

- 8** Slide the tab on the toner cartridge into the slot of the drum unit.

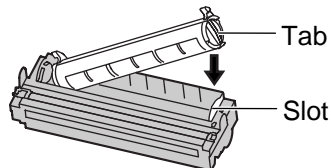

- 9a** Firmly press down on the right side of the toner cartridge to snap into position and...

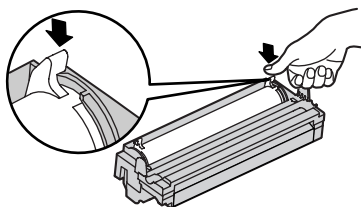

- 9b** turn the two levers on the toner cartridge with firm pressure.

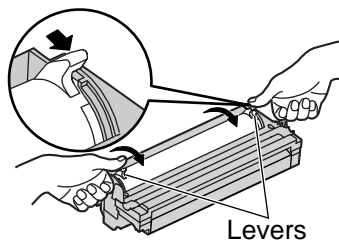

(continued)

- 10** The toner cartridge is installed when the triangles match.

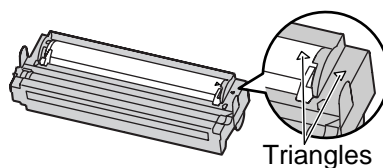

- 11** Install the drum and toner unit by holding the tabs.

- If the lower glass is dirty, clean it with a soft and dry cloth.

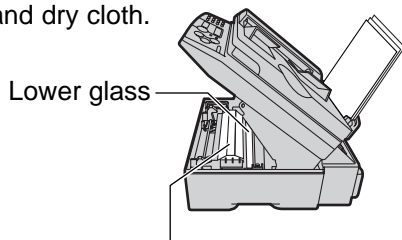

Caution:

Do not touch the bottom of this cover when cleaning the lower glass. It is very hot.

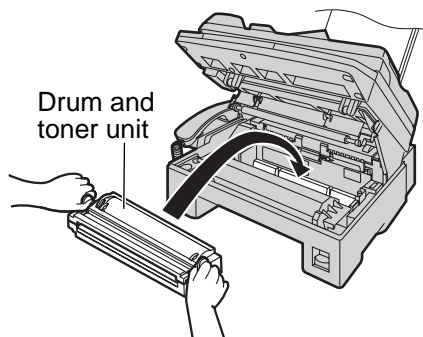

- 12** Close the printer cover by pushing down on both sides until locked.

Waste disposal method

- Waste material may be dumped or incinerated under conditions which meet all country and local environmental regulations.

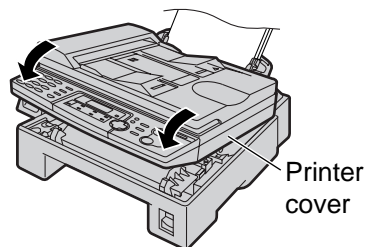

Recording paper jam

When the recording paper has jammed in the unit

The display will show the following.

Display:

PAPER JAMMED

- 1** Press down the printer cover open button then open the printer cover.

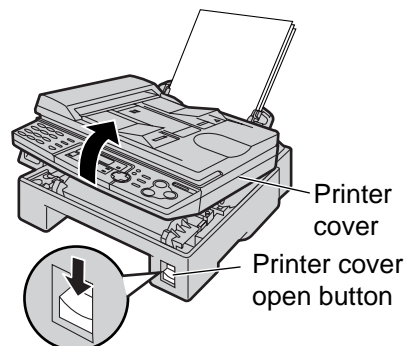

2 When the recording paper has jammed near the drum and toner unit:

Remove the jammed paper carefully by pulling it toward you.

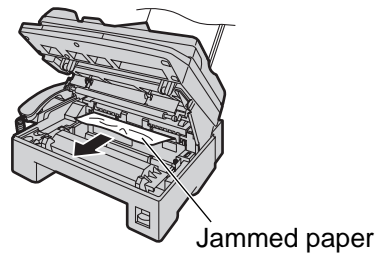

When the recording paper has jammed near the recording paper exit (Fuser unit):

Remove the recording paper (①), then remove the drum and toner unit to allow the jammed paper to pull free from the rear cabinet (②).

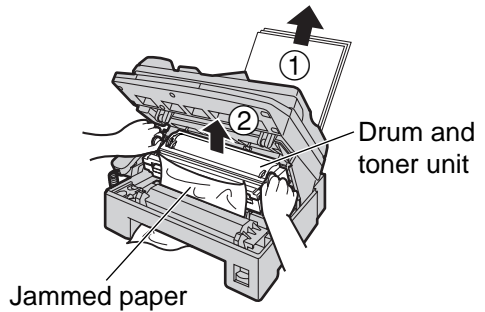

Remove the jammed paper from fuser unit by pulling it upwards carefully.



Caution: Do not touch the bottom of this cover. It is very hot.

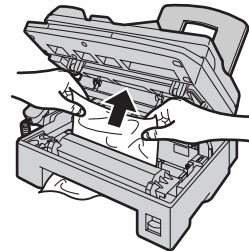
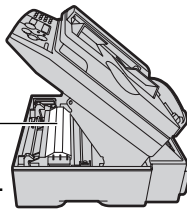

- ## 3
- Close the printer cover by pushing down on both sides until locked (①). Straighten and reinsert the recording paper into the recording paper entrance (②).

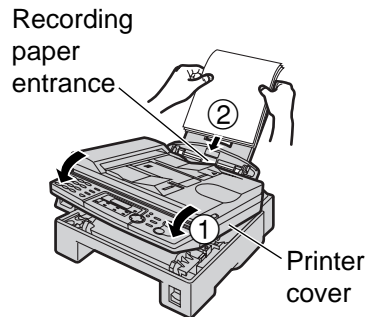

When the recording paper is not fed into the unit properly

The display will show the following.

Display: FAILED PICK UP

Remove the recording paper. Straighten and reinsert it into the recording paper entrance.

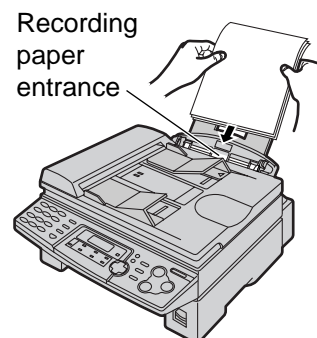

Document jams - sending

- 1 Lift, and hold open the ADF cover.
 - Do not pull out the jammed document forcibly before lifting the ADF cover.
- 2 Remove the jammed document carefully.
 - If you cannot remove the jammed document, open the document cover, remove the document, then close the document cover.

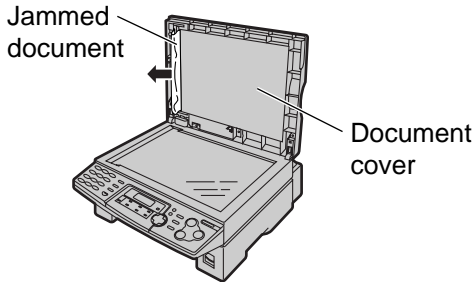
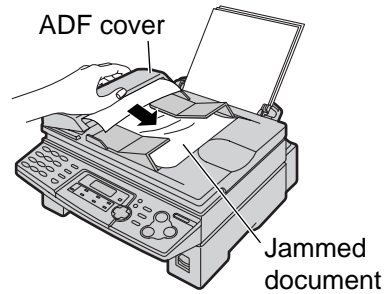

- 3 Close the ADF cover.

White plate and glasses

If a black line, a white line or a dirty pattern appears on your recording paper, on your original, or on the fax document received by the other party, clean the white plate, scanner glass and lower glass.

White plate and scanner glass

- 1 Open the document cover.
- 2 Clean the white plate and scanner glass with a soft and dry cloth.
- 3 Close the document cover.

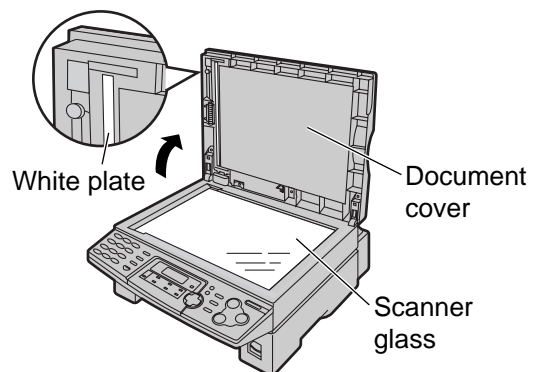

Attaching the white sheet to the document cover

If the white sheet is detached from the document cover when cleaning, place the white sheet on the scanner glass with the fastener facing up, matching the top edge of the white sheet to the "▽" mark on the unit, and close the document cover.

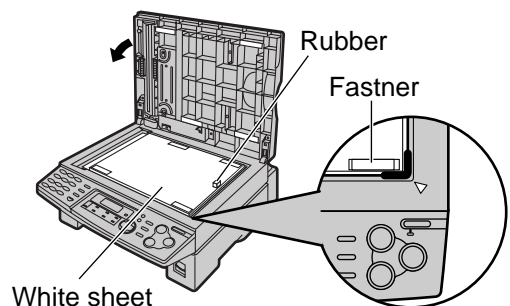

Cleaning

Lower glass

Caution:

- Be careful when handling the drum and toner unit. See the caution for the drum unit on page 73 for details.
- Do not use paper products, such as paper towels or tissues, to clean the inside of the unit.

 The area near the lower glass is hot. We recommend to clean the lower glass after the unit cools.

- 1** Disconnect the mains lead and the telephone line cord.

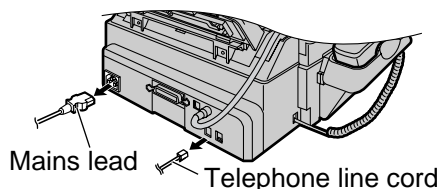

- 2** Press down the printer cover open button then open the printer cover.

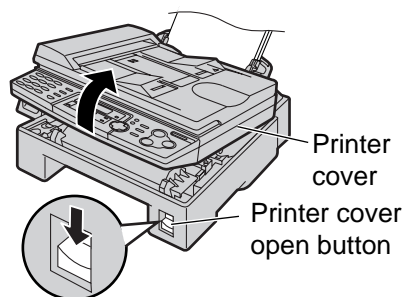

- 3** Remove the drum and toner unit by holding the two tabs.

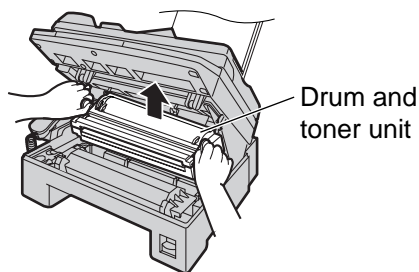

- 4** Clean the lower glass with a soft and dry cloth.



Caution:

Do not touch the bottom of this cover when cleaning the lower glass. It is very hot.

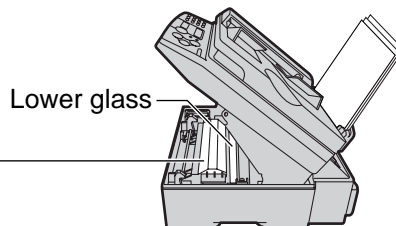

- 5** Reinstall the drum and toner unit by holding the tabs.

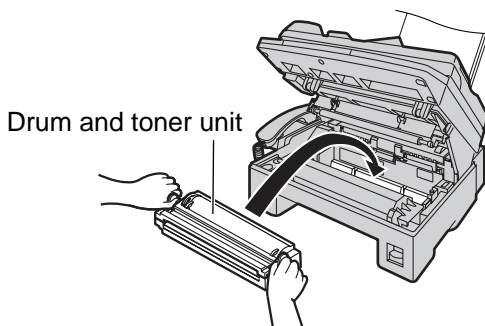

(continued)

- 6 Close the printer cover by pushing down on both sides until locked.

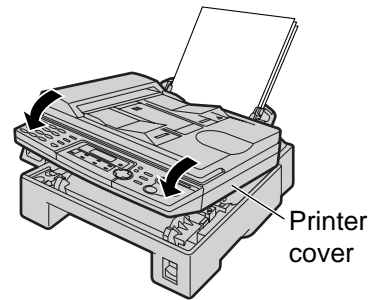

- 7 Reconnect the mains lead and the telephone line cord.

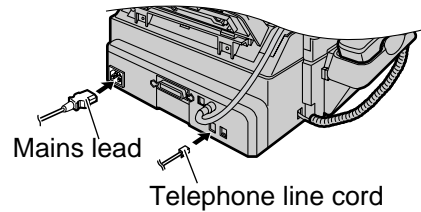

Document feeder rollers

If misfeeding of your original occurs frequently, clean the document feeder rollers.

- 1 Lift, and hold open the ADF cover.

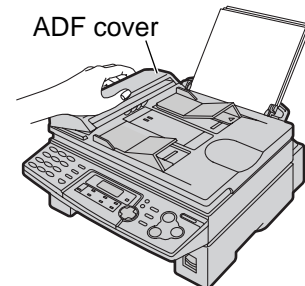

- 2 Clean the document feeder rollers with a soft and dry cloth.

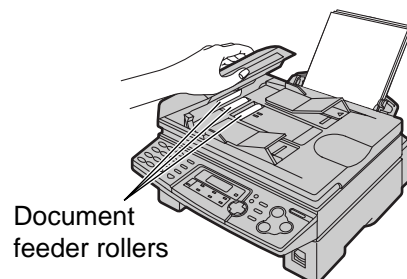

- 3 Close the ADF cover.

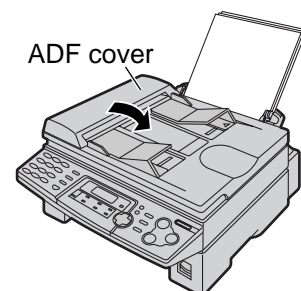

Printed Reports

Reference lists and reports

You can print out the following lists and reports for your reference.

Setup list: provides you with the current settings of the basic and advanced programming features (p. 61–65).

Telephone number list: provides you with names and telephone numbers which are stored in one-touch dial and navigator directory.

Journal report: keeps records of fax transmission and reception. This report will be printed automatically after every 30 fax communications (feature #22 on page 63).

Broadcast programming list: provides you with entries which are stored in the broadcast feature (p. 38).

Printer test list: allows you to check the print quality of your unit. If the test print has a dirty pattern, or blurred points or lines, clean the lower glass (p. 78). If printing quality is still poor, replace the toner cartridge and drum unit.

Caller ID list: keeps records of the last 30 callers after subscribing to a Caller ID service. This report will be printed automatically after every 30 callers (feature #26 on page 64).

1 Press **MENU** repeatedly until the following is displayed.

Display: PRINT REPORT
PRESS NAVI. [◀ ▶]

2 Press **◀** or **▶** until the desired item is displayed.

SETUP LIST
PRESS SET

TEL NO. LIST
PRESS SET

JOURNAL REPORT
PRESS SET

BROADCAST LIST
PRESS SET

PRINTER TEST
PRESS SET

CALLER ID LIST
PRESS SET

3 Press **SET** to start printing.

PRINTING

- To stop printing, press **STOP**.
- After printing, the printed item will be displayed.

4 Press **MENU**.

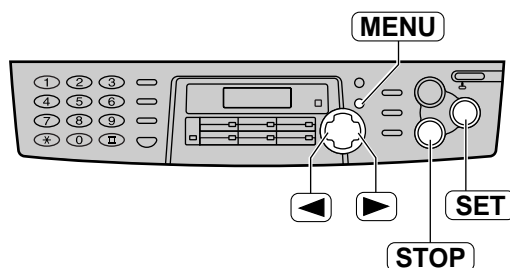

Technical data about this product

Applicable lines:	Public Switched Telephone Network
Document size:	Max. 216 mm in width / Max. 600 mm in length
Effective scanning width:	208 mm
Effective printing width:	A4: 202 mm Letter/Legal: 208 mm
Transmission time*:	Approx. 4 s/page (ECM-MMR Memory transmission)**
Scanning density:	Horizontal: 11.8 pels/mm Vertical: 3.9 lines/mm –STANDARD 11.8 lines/mm –FINE/SUPER FINE/PHOTO
Halftone level:	64-level
Scanner type:	Contact Image Sensor (CIS)
Printer type:	Laser Beam Printer
Data compression system:	Modified Huffman (MH), Modified READ (MR), Modified Modified READ (MMR)
Modem speed:	33,600 / 31,200 / 28,800 / 26,400 / 24,000 / 21,600 / 19,200 / 16,800 / 14,400 / 12,000 / 9,600 / 7,200 / 4,800 / 2,400 bps; Automatic Fallback
Operating environment:	10 °C – 32.5 °C, 20% – 80% RH (Relative Humidity)
Dimensions (H x W x D):	217 mm x 443 mm x 461 mm
Mass (Weight):	Approx. 9.2 kg
Power consumption:	Standby: Approx. 7 W Transmission: Approx. 17 W Reception: Approx. 250 W Copy: Approx. 250 W Maximum: Approx. 900 W (When the fuser unit turns on)
Power supply:	220–240 V AC, 50 Hz
Memory capacity:	Approx. 150 pages of memory transmission/reception (Based on the ITU-T No. 1 Test Chart in standard resolution.)
Laser diode properties:	Laser output: Max. 5 mW Wave length: 760 nm – 800 nm Emission duration: Continuous
Print speed:	Approx. 10 ppm (pages per minute)
Printing resolution:	600 x 600 dpi

* Transmission speed depends upon the contents of the pages, resolution, telephone line conditions and capability of the other party's machine.

** Transmission speed is based upon the ITU-T No. 1 Test Chart. If the capability of the other party's machine is inferior to your unit, the transmission time may be longer.

Note:

- Any details given in these instructions are subject to change without notice.
- The pictures and illustrations in these instructions may vary slightly from the actual product.

ITU-T No. 1 Test Chart

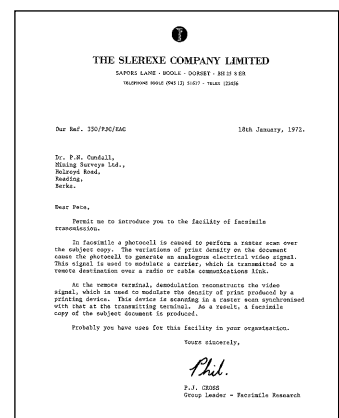

Specifications

■ Paper specifications:

Plain paper/Transparency:	A4:	210 mm x 297 mm
	Letter:	216 mm x 279 mm
	Legal:	216 mm x 356 mm
Envelope:	COM10:	105 mm x 241 mm
	DL:	110 mm x 220 mm

Note:

- Do not use the following types of paper:
 - Paper with a cotton and/or fibre content that is over 20%, such as letterhead paper or paper used for resumes.
 - Extremely smooth or shiny paper, or paper that is highly textured.
 - Coated, damaged or wrinkled paper.
 - Paper with irregularities, such as tabs or staples.
 - Paper which has dust, lint or oil stains.
 - Paper that will melt, vaporize, discolour, scorch or emit dangerous fumes, near 200 °C, such as vellum paper. These materials may transfer onto the fusing roller and cause damage.
 - Inkjet paper.
 - Moist paper.
- Some paper only accepts print on one side. Try using the other side of the paper if you are not happy with the print quality or if misfeeding occurs.
- For proper feeding and best print quality, we recommend using long-grained paper.
- Do not use paper of different types or thickness at the same time. This may cause a paper jam.
- Avoid double-sided printing.
- Do not use paper printed from this unit for double-sided printing with other copiers or printers. This may cause a paper jam.
- To avoid curling, do not open paper packs until you are ready to use the paper. Store unused paper in the original packaging, in a cool and dry location.

■ Toner life

Toner life depends on the amount of content in a received, copied or printed document.

The following is the approximate relationship between image area and toner life for Model No. KX-FA76X toner cartridge. Toner life varies in actual usage.

5% image area

10% image area

15% image area

Specifications	
Main unit specifications	
1. Applicable Lines:	Public switched telephone network
2. Compatibility:	ITU-TS G3
3. Effective Scanning Width:	Max: 209mm
4. Recording Paper Size:	Letter: 216 x 279mm Legal: 216 x 356mm
5. Effective Printing Width:	206mm
6. Transmission Times:	Approx. 30sec./sheet (3 Normal mode, H4) Approx. 17sec./sheet (3 Original mode, H4) Approx. 15sec./sheet (3 Original mode, H4)
7. Fax Redial Times:	Up to 95 times
8. Telephone Redial Times:	Up to 150 calls
9. Scanning Density:	Horizontal: 80%/mm Vertical: 3.90 lines/mm (Standard mode) 7.71 lines/mm (line or HalfPhone mode)
10. Scanner Type:	Contact image sensor

Approx. 2,000 sheets of A4 size paper can be printed.

Specifications	
Main unit specifications	
1. Applicable Lines:	Public switched telephone network
2. Compatibility:	ITU-TS G3
3. Effective Scanning Width:	Max: 209mm
4. Recording Paper Size:	Letter: 216 x 279mm Legal: 216 x 356mm
5. Effective Printing Width:	206mm
6. Transmission Times:	Approx. 28sec./sheet (3 Normal mode, H4) Approx. 17sec./sheet (3 Original mode, H4) Approx. 15sec./sheet (3 Original mode, H4)
7. Fax Redial Times:	Up to 95 times
8. Telephone Redial Times:	Up to 150 calls
9. Scanning Density:	Horizontal: 80%/mm Vertical: 3.90 lines/mm (Standard mode) 7.71 lines/mm (line or HalfPhone mode)
10. Scanner Type:	Contact image sensor
11. Printer Type:	Electrophotographic LED array printer
12. Data Compression System:	Modified Huffman (MH), Modified Read (MR), Modified Read 2 (MR2)
13. Modem Speed:	9600/2400/4800/2400bps, Automatic FallBack
14. Operating Environment:	10-32 °C 20-80%RH
15. Dimensional (W x D):	371 x 449 mm
16. Mass (kg):	Approx. 12kg
17. Power Consumption:	Standby: 13-40W Transmission: 24-200W Copy: 40-200W Main: 60W
*Transmission Time: Transmission times apply to text data using ITU-TS No. 1 test chart between the same models at maximum speed and may vary in actual usage.	

Approx. 1,000 sheets of A4 size paper can be printed.

Specifications	
Main unit specifications	
1. Applicable Lines:	Public switched telephone network
2. Compatibility:	ITU-TS G3
3. Effective Scanning Width:	Max: 209mm
4. Recording Paper Size:	Letter: 216 x 279mm Legal: 216 x 356mm
5. Effective Printing Width:	206mm
6. Transmission Times:	Approx. 28sec./sheet (3 Normal mode, H4) Approx. 17sec./sheet (3 Original mode, H4) Approx. 15sec./sheet (3 Original mode, H4)
7. Fax Redial Times:	Up to 95 times
8. Telephone Redial Times:	Up to 150 calls
9. Scanning Density:	Horizontal: 80%/mm Vertical: 3.90 lines/mm (Standard mode) 7.71 lines/mm (line or HalfPhone mode)
10. Scanner Type:	Contact image sensor HalfPhone mode
11. Printer Type:	Electrophotographic LED array printer
12. Data Compression System:	Modified Huffman (MH), Modified Read (MR), Modified Read 2 (MR2)
13. Modem Speed:	9600/2400/4800/2400bps, Automatic FallBack
14. Operating Environment:	10-32 °C 20-80%RH
15. Dimensional (W x D):	371 x 449 mm
16. Mass (kg):	Approx. 12kg
17. Power Consumption:	Standby: 13-40W Transmission: 24-200W Copy: 40-200W Main: 60W
*Transmission Time: Transmission times apply to text data using ITU-TS No. 1 test chart between the same models at maximum speed and may vary in actual usage.	
Paper specifications	
1. Paper Weight:	16-24 lbs
2. Paper Size:	4-1/2" x 11"
3. Paper Type:	100% Recycled
4. Paper Weight:	4-50 g/m ²
5. Paper Thickness:	0.075 mm
6. Paper Grain:	0°
7. Paper Surface:	Smooth
8. Paper Finish:	Uncoated
9. Paper Color:	White
10. Paper Weight:	16-24 lbs
11. Paper Size:	4-1/2" x 11"
12. Paper Type:	100% Recycled
13. Paper Weight:	4-50 g/m ²
14. Paper Thickness:	0.075 mm
15. Paper Grain:	0°
16. Paper Surface:	Smooth
17. Paper Finish:	Uncoated
18. Paper Color:	White
NOTE: The specifications are subject to change without notice.	

Approx. 650 sheets of A4 size paper can be printed.

Note:

- KX-FA79X contains 2 packs of KX-FA76X, which is increased by 20% of quantity each, compared to the single pack.
- The image area changes with the depth, thickness and size of the characters.
- If you change the toner save setting to on, the toner cartridge will last approx. 40% longer.

■ Drum life

The included drum unit or Model No. KX-FA78X can print approx. 6,000 sheets of A4 size paper regardless of the content of the image area.

Condition of guarantee

This guarantee is in addition to and does not in any way affect any statutory or other rights of consumer purchasers. If within the applicable guarantee period, the appliance proves to be defective by reason of faulty design, workmanship or materials, we undertake subject to the following conditions to have the defective appliance (or any part or parts there of) repaired or replaced free of charge.

1. The appliance shall have been purchased and used solely within the UK and in accordance with standard operating instructions and the technical and/or Safety Standards required in the UK.
2. The purchaser will within 7 days of purchase complete the included warranty registration form (folded inside front cover) and fax it to us for registration. Failure to return such a form could result in delay in providing the guarantee service.
3. The appliance should be returned together with this guarantee and proof of date of purchase promptly on being found defective at the purchaser's risk and expense to the authorised dealer from whom the appliance was purchased or to the nearest authorised dealer. All enquiries must be through such dealers.
4. This guarantee shall not apply to damage caused through fire, accident, lightning, misuse, wear and tear, neglect, incorrect adjustment or repair, to damage caused through installation, adaption, modification or use in an improper manner or inconsistent with the technical and/or safety standards required in the country where this appliance is used, or to damage occurred during transit to or from the purchaser.
5. If at any time during the guarantee period any part or parts of the appliance are replaced with a part or parts not supplied or approved by us or of an objective quality safe and suitable for the appliance, or the appliance has been dismantled or repaired by any person not authorised by us, we shall have the right to terminate this guarantee in whole or in part immediately without further notice.
6. The purchaser's sole and exclusive remedy under this guarantee against us is for the repair or replacement of the appliance or any defective part or parts and no other remedy, including, but not limited to, incidental or consequential damage or loss of whatsoever nature shall be available to the purchaser.
7. This guarantee shall not apply to cassette tapes, batteries and any other items of limited nature life.
8. Our decision on all matters relating to complaints shall be final. Any appliance or defective part which has been replaced shall become our property.
9. The guarantee period applicable to this product shall be 12 months from the date of purchase.

Please keep these Operating Instructions with your receipt.

Panasonic Business Systems U.K.

Receipt No. _____	Date of Purchase _____
Model No. KX-FLB756E _____	Serial No. _____

Program index

Basic features

Code Feature name

#01	Date and time	21
#02	Your logo	22
#03	Your facsimile telephone number	24
#04	Sending report	35, 61
#06	FAX ring setting	61
#12	Remote activation ID	61
#15	Cable selection	62
#16	Paper size	62
#17	Ringer pattern	25, 62

Advanced features

Code Feature name

#22	Journal report	35, 63
#23	Overseas mode	63
#25	Delayed transmission	63
#26	Caller ID list	64
#37	Auto reduction	64
#39	Display contrast	64
#41	Remote fax activation code	47, 64
#44	Fax receiving alert	65
#68	ECM selection	65
#76	Connecting tone	65
#79	Toner save	65
#80	Reset advanced features	65

Index

A	Accessories	10, 11
	(Paper stacker)	18
	(Paper tray)	18
	Advanced features	63–65
	Alert	
	(Memory reception) (Feature #44)	65
	Answering machine	46
	Auto document feeder	34, 48
	Auto reduction (Feature #37)	44, 64
B	Basic features	61, 62
	Broadcast transmission	38
	Buttons / Keys	
	(AUTO ANSWER)	44, 45
	(BROADCAST)	38, 41
	(CALLER ID)	31, 33
	(COLLATE)	49
	(Delete)	22
	(HELP)	12
	(Insert)	22
	(LOWER)	26, 29, 37
	(MANUAL BROAD)	38, 41
	(MONITOR)	29
	(REDIAL)	34
	(RESOLUTION)	34, 48
	(SCAN)	34, 35, 49, 56
	(Station)	26, 29, 37
C	Cable selection (Feature #15)	50, 62
	Caller ID	30
	(Calling back)	31
	(Storing)	33, 57
	Caller ID list (Feature #26)	30, 64
	Character table	23
	Cleaning	77–79
	Communication messages	66
	Connecting tone (Feature #76)	65
	Connections	20, 50
	Copy	48
	(Collation)	49
	(Enlarge)	49
	(Reduce)	49
D	Date and time (Feature #01)	21, 61
	Delayed transmission (Feature #25)	63
	Display	
	(Contrast)(Feature #39)	64
	(Error messages)	67, 68

<p>Document size36</p> <p>Drum life82</p> <p>Drum unit16, 73</p> <p>Dual Access feature35</p> <p>E ECM selection (Feature #68)65</p> <p>Envelope55</p> <p>Error messages66–68</p> <p>Extension telephone47</p> <p>F Facsimile telephone number (Feature #03)24, 61</p> <p>Fax activation code (Feature #41)47, 64</p> <p>Fax auto redial37</p> <p>FAX ONLY mode45</p> <p>Fax receiving42, 43</p> <p>H Help12, 52</p> <p>J Jams (Document)77 (Paper)75, 76</p> <p>Journal report (Feature #22) ...35, 63</p> <p>L Label54</p> <p>Logo (Feature #02)22, 61</p> <p>M Memory reception44</p> <p>Multi-Function Station software (Activating)52 (Installing)51</p> <p>N Navigator directory (Making a phone call)29 (Selecting characters)23 (Sending faxes)37 (Storing)27, 57</p> <p>O OCR software56</p> <p>One-touch dial (Making a phone call)29 (Sending faxes)37 (Storing)26, 57</p> <p>Overseas mode (Feature #23)63</p> <p>P Paper size (Feature #16)62</p> <p>Parallel cable50</p> <p>Power failure72</p> <p>Printer53</p> <p>Printing paper size53, 82</p> <p>Q Quick scan feature35</p>	<p>R Receiving alert (Feature #44)65</p> <p>Receiving setting42, 43</p> <p>Recording paper19</p> <p>Remote activation ID (Feature #12) .61</p> <p>Remote control57</p> <p>Reports (Broadcast programming)80 (Broadcast sending)41 (Caller ID)30, 57, 64 (Journal)35, 57, 80 (Power down)72 (Printer test)80 (Sending)35 (Setup)80 (Telephone number)80</p> <p>Reset (Feature #80)65</p> <p>Resolution34, 48</p> <p>Ring setting (FAX ONLY)(Feature #06)61</p> <p>Ringer pattern (Feature #17)25, 62</p> <p>S Scanner56</p> <p>Scanner glass35, 48</p> <p>Sending (Broadcast)41 (Manually)34, 35 (Navigator directory)37 (One-touch dial)37 (Quick scan)35</p> <p>Sending report (Feature #04) ...35, 61</p> <p>Set default (Feature #80)65</p> <p>Shipping lock15, 67</p> <p>Storing (Broadcast)38, 57 (Navigator directory)27, 57 (One-touch dial)26, 57</p> <p>T TEL mode44</p> <p>Toner cartridge16, 73</p> <p>Toner life82</p> <p>Toner save (Feature #79)17, 65</p> <p>Transparency54</p> <p>U USB cable50</p> <p>V Viewer56</p> <p>Volume25</p>
--	---

CE 0682

Sales Department:

Panasonic Business Systems U.K.

Panasonic House, Willoughby Road, Bracknell, Berkshire, RG12 8FP

Panasonic Communications Co., Ltd.

1-62, 4-chome, Minoshima, Hakata-ku, Fukuoka 812-8531, Japan

PFQX1822ZA DM0303NK0

Free Manuals Download Website

<http://myh66.com>

<http://usermanuals.us>

<http://www.somanuals.com>

<http://www.4manuals.cc>

<http://www.manual-lib.com>

<http://www.404manual.com>

<http://www.luxmanual.com>

<http://aubethermostatmanual.com>

Golf course search by state

<http://golfingnear.com>

Email search by domain

<http://emailbydomain.com>

Auto manuals search

<http://auto.somanuals.com>

TV manuals search

<http://tv.somanuals.com>