

Panasonic

Digital Super Hybrid System
KX-TD816CE
KX-TD1232CE

User Manual Addendum
for
KX-TD7500CE

In this manual, the last letter “CE” of each model number is omitted.

Introduction

This User Manual Addendum provides information for the Panasonic DECT Portable Station (PS), KX-TD7500.

Up to 16 PSs in the KX-TD816 system and up to 64 PSs in the KX-TD1232 system can be used as extensions. To use the PS, the following equipment is required.

2-RF Interface Unit with 4-Station Line (KX-TD144)

The KX-TD144 must be optionally equipped with the Panasonic Digital Super Hybrid System, KX-TD816 / KX-TD1232.

One KX-TD144 supports up to two Cell Stations (KX-TD142) and eight wired extensions. One KX-TD144 can be installed to the KX-TD816 and up to two KX-TD144s can be installed to the KX-TD1232.

Cell Station (KX-TD142)

This unit determines the range of the supporting PSs. Up to four calls can be made at the same time in the range.

For more details about the KX-TD144 and KX-TD142, please refer to the Installation Manual Addendum for the KX-TD144 / KX-TD142 / KX-TD7500.

The Cell Station (KX-TD142) in this product is a Restricted Product subject to the laws of your country. It should not be exported or brought out of your country without authorization from the appropriate governmental authorities.

Accessories

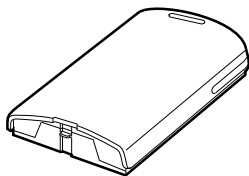

Rechargeable
Battery

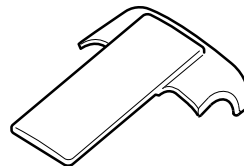

Handset Clip

Contents

Location of Controls	4
About the LCD (Liquid Crystal Display)	6
Installing the Batteries	8
Installing a Battery	8
Replacing a Battery	8
Charging a Battery.....	9
Initial Settings	10
Registering the PS	10
Selecting the Display Language.....	10
Adjusting the Ringer Volume	11
Adjusting the Receiver Volume.....	11
Installing the Handset Clip	12
Basic Operations	13
Making Calls	13
Answering Calls	17
Call Hold	18
Key Lock Setting.....	19
Using the Directory	20
Storing Names and Numbers in the PS Dialing Directory	22
Storing Names and Numbers in the PBX Station Speed Dialing Directory/Editing an Item in the PS Dialing and PBX Station Speed Dialing Directory.....	24
Dialing Using the Directory	26
Erasing an Item from the PS Dialing/PBX Station Speed Dialing Directory	28
Entering Characters	29
Key Operations	31
Other Operations	32
Programming Overview	43
PS Programming	44
PS Programming Items Description.....	44
PS Programming Operations	49
PBX Programming	52
PBX Programming Overview	52
PBX Programming Operations.....	53
Before Requesting Help	54
Safety Instructions	56

Location of Controls

Portable Station

Ringing Indicator

Flashes green when an incoming call is received.

Volume Control Button

Used to select the ringer or receiver volume.

INT

(Intercom) Button

Used to make or receive intercom calls.



(Talk) Button

Used to make, receive or end calls.



(Cancel) Button

Used to end calls, or exit the directory or Function mode.



(Hold) Button

Used to place a call on hold.



(Function) Button

Used to enter into the Function mode or access features by pressing additional keys.



(Auto/OK) Button

Used for System Speed Dialing and storing program changes.

Antenna

Display

F1-F3 (Flexible CO) Buttons (F1 through F3)

Used to seize a CO line or access one of several features.



(Clear/Transfer) Button

Used to clear incorrect digits while entering numbers, and transfer a call to another extension.



(Book) Button

Used to enter into the directory mode or select a menu in the Function mode.



(Flash) Button

Used to disconnect a current call and make another call.



(Redial) Button

Used to redial the last number dialed.

Combination buttons

⏸ (Pause) Button ((F) + (1))

Used to insert a pause in numbers.

⏪/⏩ (FWD/DND) Button ((F) + (ABC 2))

Used to set the Call Forwarding or Do Not Disturb (DND) features.

✉ (Message) Button ((F) + (DEF 3))

Used to leave a notification to the called party or call back the message sender (Message Waiting).

⚠ (Conference) Button ((F) + (GHI 4))

Used to establish a three party conversation.

🔔 (Tone) Button ((F) + (JKL 5))

Used to change the dialling mode temporarily to tone (Pulse to Tone Conversion).

Note: These buttons can also be activated using the display. Refer to the Key Operations on page 31.

Location of Controls

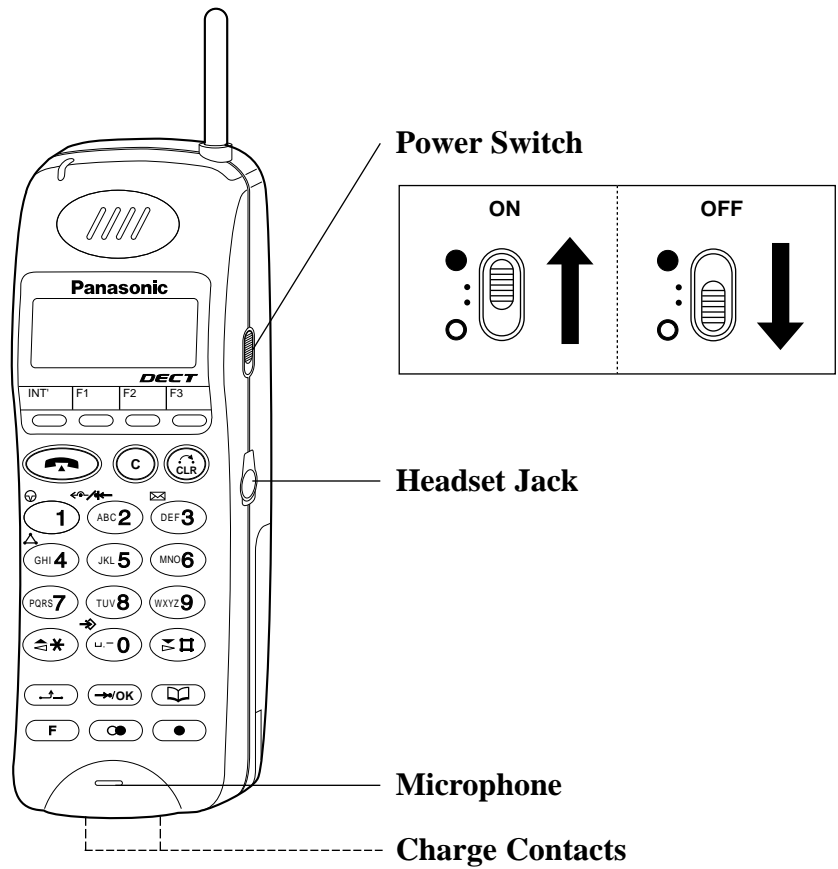

Charger (KX-A275)

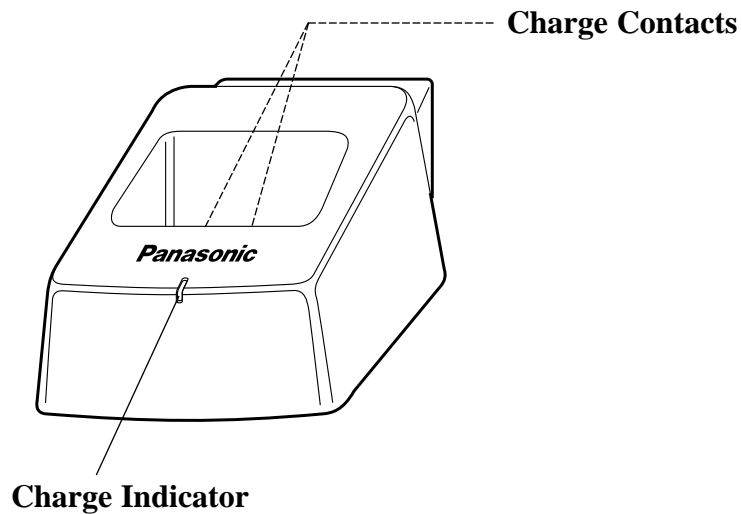





About the LCD (Liquid Crystal Display)

The display has two lines with 16 characters per line, and related symbols to show information for call activities as shown below.



Symbols and Descriptions

	In off-hook status.
	In the Function mode.
	In the Directory or Programming mode.
	Message Waiting notification. Someone is waiting for your call.

The radio signals from the Cell Station

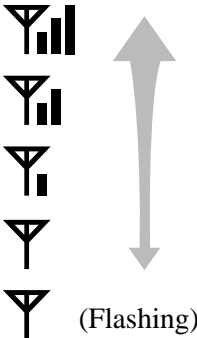
	<p>Strong</p> <p>Medium</p> <p>Weak</p> <p>The portable station is out of range. Move closer to the CS.</p>
---	---

The battery strength

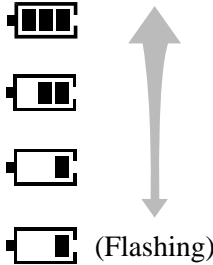
	<p>Fully charged.</p> <p>Medium</p> <p>Low</p> <p>The battery needs to be charged.</p>
---	--

About the LCD (Liquid Crystal Display)

After setting the Power Switch to ON, the following displays may appear.



The portable station is in the stand-by mode.
The date and time (day / month / time) are displayed on the top line. You can select displaying the date only (day / month) in PS Programming. (Selecting the Date / Time Display)
The number which is determined in PS Programming (e.g., your extension number) can be displayed on the bottom line. (Selecting the Standby Display; default – OFF)

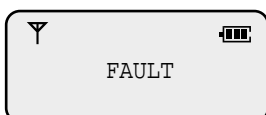

Consult with your dealer.



The Call Forwarding feature has been set.



The Do Not Disturb (DND) feature has been set.

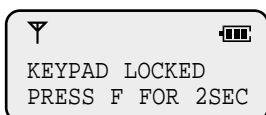

The key lock mode has been set to ON. To cancel the mode, press **F** (Function) for 2 seconds. (Refer to page 19.)

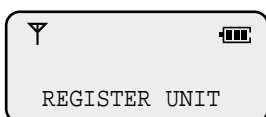

Your PS is not registered in the system.

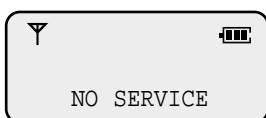

Your PS is out of range.

Installing the Batteries

You need to charge the battery before initial use and when the battery strength becomes low.

When the battery strength becomes low, “” flashes or beep tones sound every five seconds. During a conversation, the call will hang up automatically within three minutes. If idle or in the programming status, “BATTERY EMPTY” is displayed and the key operation is canceled. In these cases, recharge the battery or replace with a fully charged optional spare battery.

Standard Battery Life

If your Panasonic battery is fully charged [provided 25°C (77°F)]:

While in use (Talk mode)	Up to about 10 hours
While not in use (Stand-by mode)	Up to about 100 hours

Note:

- The battery is used while the portable station’s power is ON.
- Battery life may vary depending on usage conditions and ambient temperature.
- Please use only a Panasonic battery.

Installing a Battery

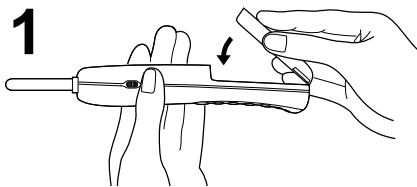

Hook the bottom of the battery on the portable station, and place the battery in the portable station until you hear a click.

Replacing a Battery

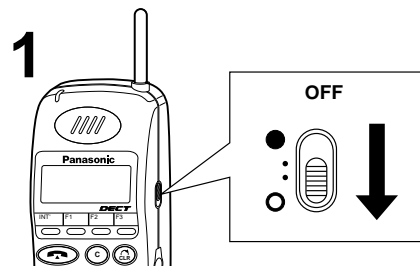

Set the Power switch to OFF to prevent memory loss.

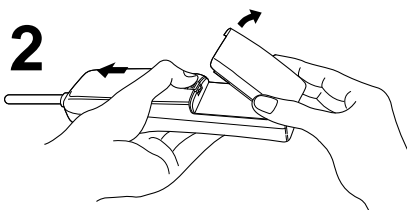

While pressing the open-button, remove the battery.

Installing the Batteries

Charging a Battery

- 1 Connect the Charger to a power outlet using the AC adaptor.

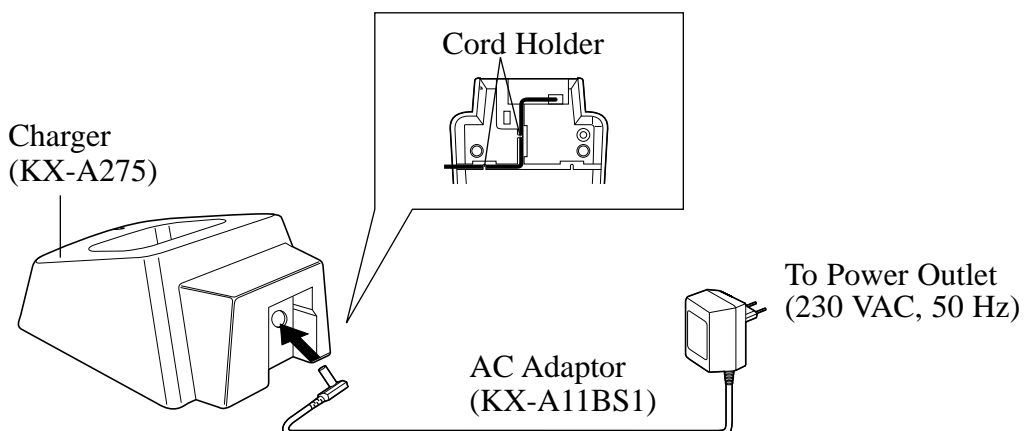

2

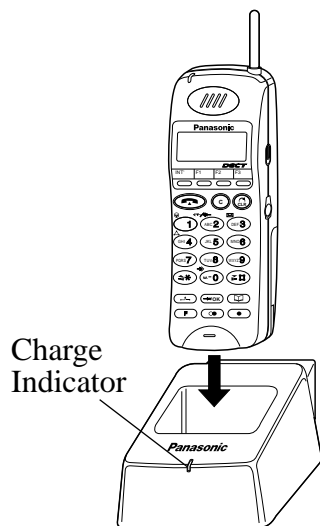

Slide the battery-attached portable station or the battery in the Charger.

Charge the battery for about 1.5 hours. When charging is completed, the charge indicator will change from orange to green.

CAUTION

The AC adaptor is used as the main disconnect device, ensure that the socket-outlet is located / installed near the equipment and is easily accessible.

- Note:**
- Do not let the charged battery's electrodes to touch metallic objects. The terminal may short and overheat, causing burns.
 - Clean the charge contacts on both the portable station and the Charger with a soft cloth once a month, or the battery may not charge properly.
 - The portable station can receive calls even while charging.
 - You need not worry about overcharging.

Initial Settings















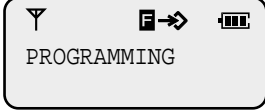

Registering the PS

After charging the battery, you must register your PS in the system and determine its' extension number.

For registration, refer to **System Program [650], "PS Registration"**, in Section 3 in the Installation Manual Addendum for the KX-TD144/KX-TD142/KX-TD7500.

Selecting the Display Language

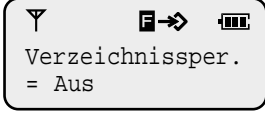
The default setting of the PS displaying language is "AUTO (English)". For example, to select the German display, see the method below. If your PS is assigned to the Digital Super Hybrid System while the default setting is still "AUTO", the displaying language will depend on the setting of the system.

- 1** Press  (Function).

- 2** Press  (Book) 2 times.
 - You can also search by pressing  (Next) or  (Previous).
- 3** Press  (OK).

- 4** Press  (OK).

- 5** Press  (Next) or  (Previous) repeatedly until the display for the Language Selection appears.

- 6** Press  (Book) repeatedly until the language you use is displayed.

- 7** Press  (OK).

- 8** To exit the PS Programming mode, press  (Cancel).

Initial Settings

Adjusting the Ringer Volume

The ringer volume has **seven levels** which is indicated by the number of asterisks on the display. [Default: *** (level 3)]

If you do not want your portable station to ring, you can select **Off**, or **Vibration** which is convenient while in a meeting, etc.



During on-hook status or when the portable station is ringing

Press the **VOLUME** (UP \wedge / Down \vee) Control button.

Example: Level 3

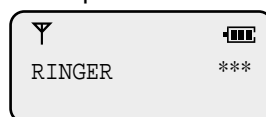

Example: Off

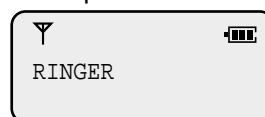

Example: Vibrating

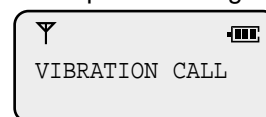

Note

- In addition to the ringer patterns above, there are several combination of vibration and ring types. Refer to “Selecting the Vibration and Ring Type” in PS Programming.
- The portable station rings for an incoming call while charging even when it is set to vibrate.

Adjusting the Receiver Volume

The receiver volume has **three levels** which is indicated by the number of asterisks on the display.



During a conversation

Press the **VOLUME** (UP \wedge / Down \vee) Control button.

Example: Level 2

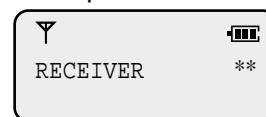

Installing the Handset Clip

You can hang the PS on your belt or pocket by attaching the handset clip.

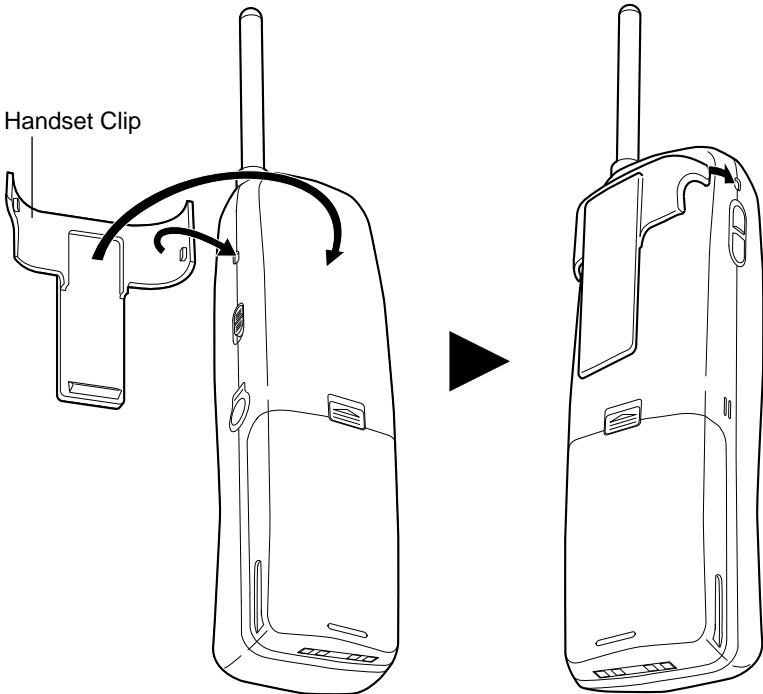











Basic Operations

Making Calls

Intercom Calls

Make sure the Power Switch is set to ON (●) and “Y” is displayed.

- 1** Press  (Talk) or  (Intercom).

- 2** Enter the **extension number**.
 - The dialed number is displayed.
 - If you misdial, press  (Flash) and enter the number again.
- 3** **Talk** after the called party answers.

- 4** Press  (Cancel) after the conversation is finished.

- Note:**
- Predialing is also possible. In this case, reverse steps 1 and 2.
 - If you misdial while predialing, press  (Clear) to clear each digit from the last one, and enter the number again.
 - You can also finish the conversation by placing the PS on the Charger or pressing  (Talk).
 - If “Y” flashes, move towards the Cell Station and try again.

Handover: Even if you move during a conversation, the linking CS is automatically switched without disconnecting the call. Handover is available only during a conversation (except a conference call). It is not available when the switched CS is busy or there is no CS in the moving range.

Basic Operations









Outside Calls

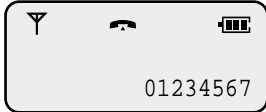

There are three types of line access methods as follows:

- 1) **Line Access, Automatic:** selects an idle CO line.
- 2) **Line Access, CO Line Group:** selects an idle CO line in the desired CO line group.
- 3) **Line Access, Individual:** selects a specific CO line.

Make sure the Power Switch is set to ON (●) and “〒” is displayed.

Line Access, Automatic / CO line group

- 1 Press  (Talk).

- 2 Enter the **line access code**.
 - **9** : Automatic
 - **81 through 88** : CO Line Group
- 3 Enter the **phone number**.
 - The dialed number is displayed.
 - The display starts counting the call duration (or charge, if programmed).
 - If you misdial, press  (Flash) and enter the number again.
- 4 **Talk** after the called party answers.

- 5 Press  (Cancel) after the conversation is finished.

- Note:**
- Predialing is also possible. In this case, press  (Talk) (step 1) after entering the phone number (steps 2 and 3).
 - You can also finish the conversation by placing the PS on the Charger or pressing  (Talk).
 - If “〒” flashes, move towards the Cell Station and try again.

Basic Operations

Line Access, Individual

1 Press  (Flexible CO).



2 Enter the **phone number**.

- The dialed number is displayed.
- The display starts counting the call duration (or charge, if programmed).
- If you misdial, press  (Flash) and enter the number again.

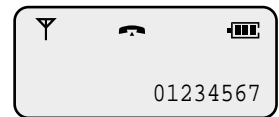



3 **Talk** after the called party answers.



4 Press  (Cancel) after the conversation.





- Note:**
- Predialing is also possible. In this case, reverse steps 1 and 2.
 - You can also finish the conversation by placing the PS on the Charger or pressing  (Talk).
 - If “” flashes, move towards the Cell Station and try again.

Basic Operations

Redialing a number in the call log

Your PS automatically saves the last five outside numbers you dialed. You can make a call by selecting the desired log number.

Redialing

- 1 Press  (Redial) repeatedly until the desired log number is displayed.
 - You can also search by pressing  (Next) or  (Previous).

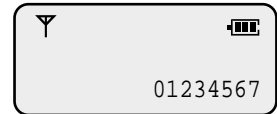

- 2 Press  (Talk) or  (Flexible CO).

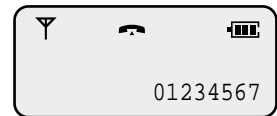

Clearing all of the numbers in the call log

- 1 Press  (Redial).

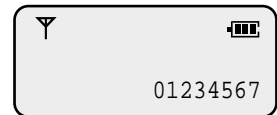

- 2 Press  (Clear).



- Note:**
- Extension numbers cannot be logged.
 - You can also execute the redialing or clearing the call log operation after going off-hook.



Basic Operations

Answering Calls



When you receive a call, the portable station (PS) rings or vibrates, and the CO line number or extension number of the receiving call appears on the display.

Make sure the Power Switch is set to ON (●) and “∇” is displayed.

If the PS is not on the Charger

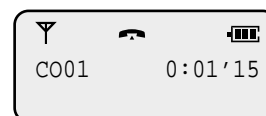
- 1 Press  (Talk) or the flashing  (Flexible CO).
 - The display starts counting the call duration (or charge, if programmed).





- 2 To hang up, press  (Cancel) or  (Talk) or **place the PS on the Charger.**

If the PS is on the Charger (Quick Answering)

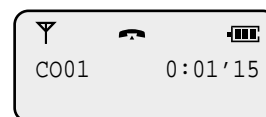
- 1 **Just lift up** the PS.
 - The display starts counting the call duration (or charge, if programmed).



- 2 To hang up, press  (Cancel) or  (Talk) or **place the PS on the Charger.**

Note: – Quick Answering is available only when the Quick Answering mode is set to “ON”. Refer to “Setting the Quick Answering Mode” in PS Programming.

If a headset is connected to the PS

You can select the answering mode by PS Programming as follows.

- **OFF** (default): Answers using normal operations.
(Refer to the operations above.)
 - **INT/CO**: Automatically receives all incoming calls.
 - **INT ONLY**: Automatically receives incoming intercom calls.
- To select the automatic answer mode, refer to “Setting the Automatic Answer Mode” in PS Programming.

Basic Operations

Call Hold



You can place a call on hold. Exclusive hold is also possible so that no one can retrieve the call.

Placing a call on hold

- 1 Press  (Hold) during a conversation.



Retrieving a call on hold

- 1 Press the  (Flexible CO) or  (Intercom) button which is flashing green slowly.





Note: – You can retrieve a call on hold which has been placed on hold by another extension. Refer to “DPT Features – Call Hold Retrieve” in the User Manual for the model KX-TD816 / KX-TD1232.

Placing a call on exclusive hold

- 1 Press  (Hold) twice during a conversation.



Retrieving a call on exclusive hold

- 1 Press the  (Flexible CO) or  (Intercom) button which is flashing green moderately.



Basic Operations

Key Lock Setting

You can lock the dialing buttons. Incoming calls can be answered, but no outgoing calls can be dialed.

Setting

While on-hook

Press **F** (Function) for 2 seconds.

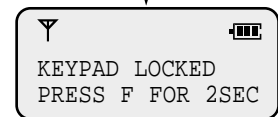

Canceling

While on-hook

Press **F** (Function) for 2 seconds.

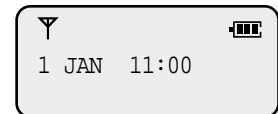

Using the Directory

You can store names and/or phone numbers in the directory. A stored number is dialed out by selecting a name or phone number in the directory. There are four types of directory features, including one PS directory and three PBX directories, as follows.

PS Dialing Directory:

You can store up to 100 private names and phone numbers of outside parties. All directory items are stored in alphabetical order. To store the names and numbers, refer to page 22.

PBX System Speed Dialing Directory:

You can make a call via the system by selecting system-assigned names and phone numbers. To store the names and numbers (500 max.), refer to program [001-002], "System Speed Dialing Number/Name Set" in System Programming of the KX-TD816/KX-TD1232 Installation Manual.

PBX Extension Dialing Directory:

You can make a call via the system by selecting system-assigned extension names. To store the names, refer to program [004], "Extension Name Set" (in System Programming of the KX-TD816/KX-TD1232 Installation Manual) and [653], "PS Extension Name Set" (in Installation Manual Addendum for the KX-TD144/KX-TD142/KX-TD7500).

PBX Station Speed Dialing Directory:

You can make a call via the system by selecting your privately assigned names and phone numbers. To store the names and numbers (10 max.), refer to page 24.

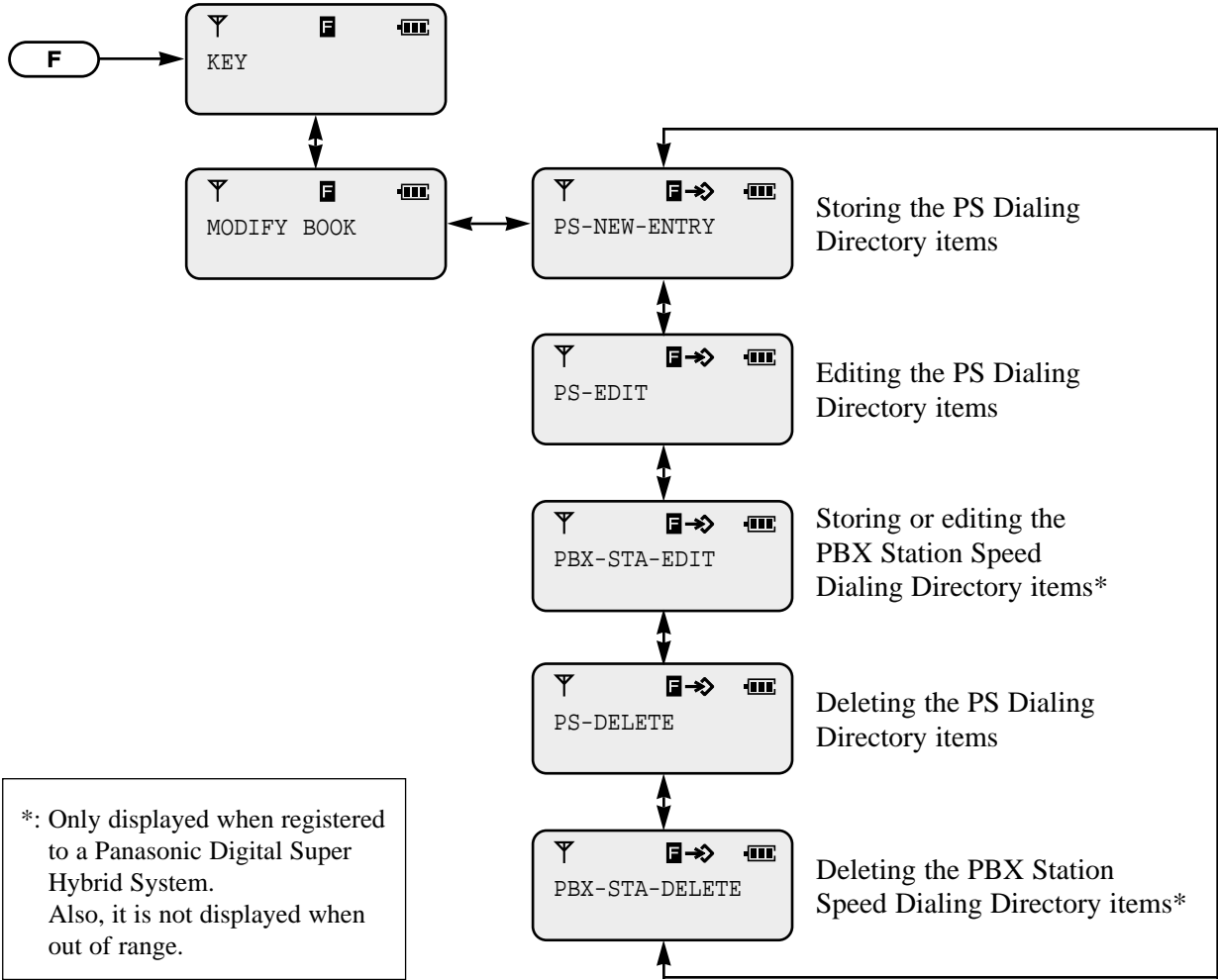

You can store, edit or delete the PS Dialing Directory or PBX Station Speed Dialing Directory items at your PS. There are five displays for directory entry/edition/deletion as shown on the next page.

Using the Directory













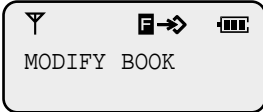

Using the Directory

Storing Names and Numbers in the PS Dialing Directory

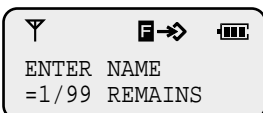
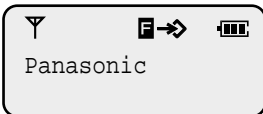
- Note:**
- If you misdial, press  (Clear) to clear each digit from the last one, and enter the number again.
 - Press  (Cancel) to exit the Directory mode.

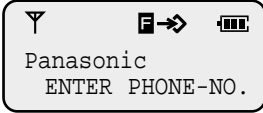
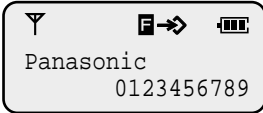
Storing from Name to Phone Number

- 1** Press  (Function).

- 2** Press  (Book).
 - You can also search by pressing  (Next) or  (Previous).
- 3** Press  (OK).

- 4** Press  (OK).
 - The number of stored items and remaining capacity are displayed.
- 5** Enter the **name** (up to 16 characters). (Refer to page 29.)
 - If you only want to store a phone number, skip this step.
- 6** Press  (OK).

- 7** Enter the **phone number** (up to 32 digits).

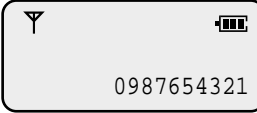
- 8** Press  (OK).

Using the Directory

Storing from Phone Number to Name

- 1** Enter the **phone number** (up to 32 digits).



- 2** Press **F** (Function).

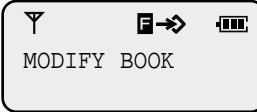

- 3** Press **Book** (Book).

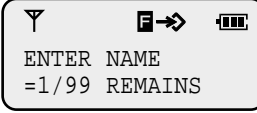
 - You can also search by pressing **Next** (Next) or **Previous** (Previous).
- 4** Press **OK** (OK).

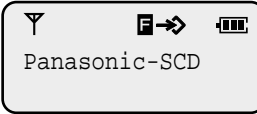
- 5** Press **OK** (OK).

 - The number of stored items and remaining capacity are displayed.
- 6** Enter the **name** (up to 16 characters).

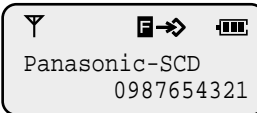
 - If you only want to store a phone number, skip this step.
- 7** Press **OK** (OK).

- 8** Press **OK** (OK) again.





Using the Directory

Storing Names and Numbers in the PBX Station Speed Dialing Directory / Editing an Item in the PS Dialing and PBX Station Speed Dialing Directory

1 Press  (Function).



2 Press  (Book).

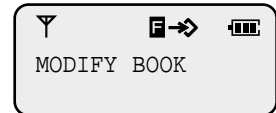

- You can also search by pressing  (Next) or  (Previous).



3 Press  (OK).



4 Press  (Book) repeatedly until the desired “EDIT” display appears.
– PS-EDIT: PS Dialing Directory
– PBX-STA-EDIT: PBX Station Speed Dialing Directory

- You can also search by pressing  (Next) or  (Previous).

Example



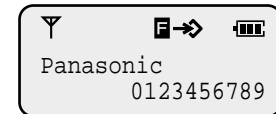

5 Press  (OK).



6 **To edit an item**, press  (Book) repeatedly until the desired item is displayed.

To store an item in the PBX Station Speed Dialing Directory for the first time, press  (Book) repeatedly to select the blank display.

- You can also search by pressing  (Next) or  (Previous).

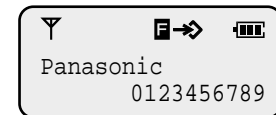

7 Press  (OK).

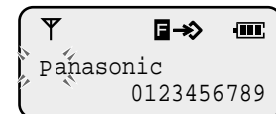

Using the Directory

8 Edit the **name**. (Refer to page 29.)

- Up to 10 characters can be stored in the PBX Station Speed Dialing Directory.
- If you only want to edit a phone number, skip this step.



9 Press (OK).

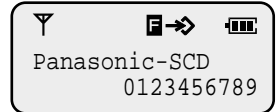

10 Edit the **number**.

- Up to 24 digits (including the CO line access code) can be stored in the PBX Station Speed Dialing Directory.
- If you only want to edit a name, skip this step.

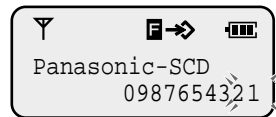



11 Press (OK).

- You can store, edit or delete directory items continuously.



Example



- Note:**
- It is not possible to edit the items in the PBX System Speed Dialing or PBX Extension Dialing Directories.
 - The CO line access code must be entered to store the phone number of an outside party in the PBX Station Speed Dialing Directory, while it is not required in the PS Dialing Directory.
 - If you misdial, press  (Clear) to clear each digit from the last one, and enter the number again.
 - Press  (Cancel) to exit the Directory mode.

Using the Directory

Dialing Using the Directory

There are two ways you can dial for items in the directory.

- Dialing by selecting the name
- Dialing by selecting the entry

There are four displays for directory dialing as follows.

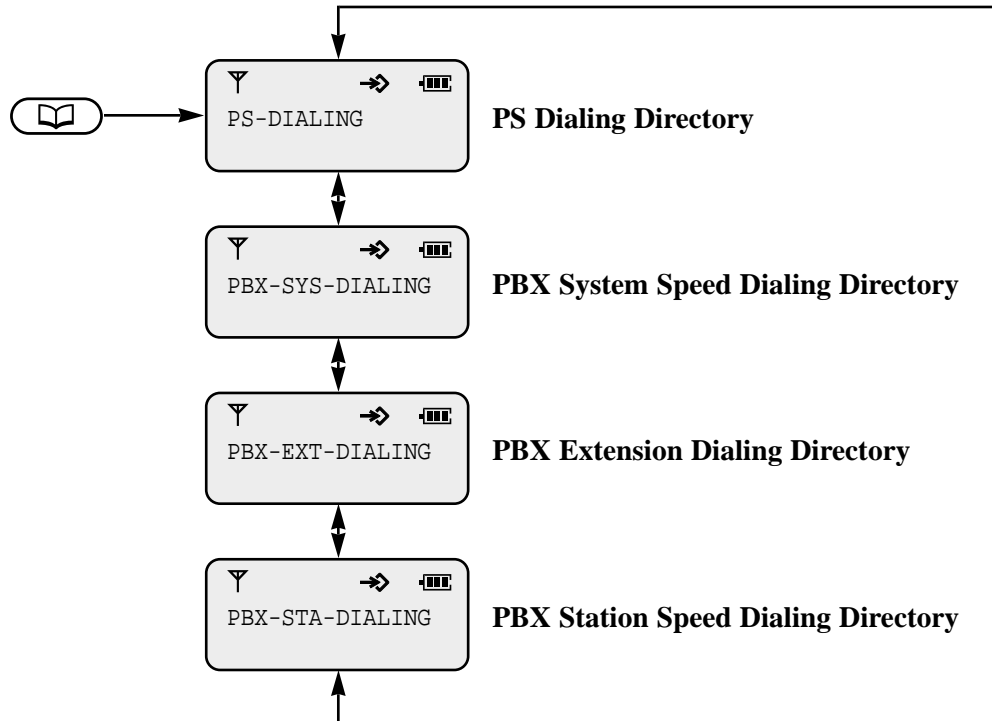

- Note:**
- Press (Cancel) to exit the Directory mode.
 - These displays do not appear when registered to a PBX other than the Panasonic Digital Super Hybrid System or when out of range. In this case, the directory item (e.g., display in step 2 in “Dialing by selecting the name”) appears after pressing (Book).
 - Transferring a call using the directory item is also possible. In this case, press (Transfer) during a conversation and then dial by selecting the directory item.

Dialing by selecting the name

- 1 Press (Book) repeatedly until the desired directory feature is displayed.

Example

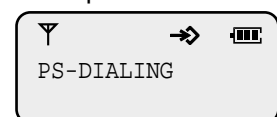

Using the Directory

2 Press  (OK).

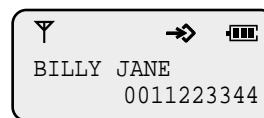



3 Press the dialing button of the letter of the desired name repeatedly until the first item under the desired letter is displayed. (Refer to page 29.)

Example



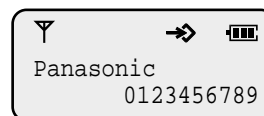

4 Press  (OK).

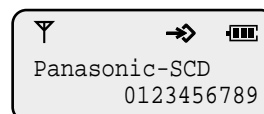

5 Press the  (Next) or  (Previous) repeatedly until the desired item is displayed.



6 Press  (Talk),  (Intercom) or  (Flexible CO).

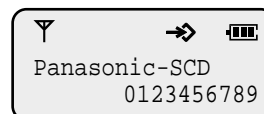

Dialing by selecting the entry



1 Press  (Book) repeatedly until the desired directory feature is displayed.

Example

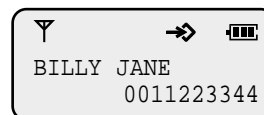

2 Press  (OK).



3 Press the  (Next) or  (Previous) repeatedly until the desired item is displayed.

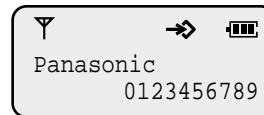

4 Press  (Talk),  (Intercom) or  (Flexible CO).

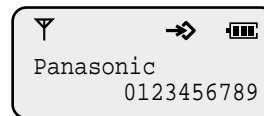



Using the Directory

Erasing an Item from the PS Dialing / PBX Station Speed Dialing Directory

1 Press  (Function).



2 Press  (Book).

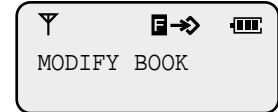

- You can also search by pressing  (Next) or  (Previous).



3 Press  (OK).



4 Press  (Book) repeatedly until the desired “DELETE” display appears.

- You can also search by pressing  (Next) or  (Previous).



Example

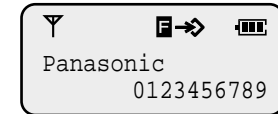

5 Press  (OK).



6 Press  (Book) repeatedly until the desired item that you want to edit is displayed.

- You can also search by pressing  (Next) or  (Previous).

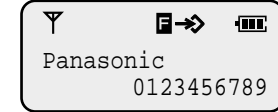

7 Press  (OK).

- You can store, edit or delete directory items continuously.



Example



- Note:**
- It is not possible to delete the items in the PBX System Speed Dialing or PBX Extension Dialing Directories.
 - Press  (Cancel) to exit the Directory mode.



Using the Directory

Entering Characters

Dialing buttons can be used as letters and symbols for character input keys. Pressing each button selects a character as shown below. While entering characters, the cursor will flash on the display.

Combination Table

	Number of pressing times								
Keys	1	2	3	4	5	6	7	8	9
1	Ä	ä	Ö	ö	Ü	ü	1		
2	A	a	B	b	C	c	2		
3	D	d	E	e	F	f	3		
4	G	g	H	h	I	i	4		
5	J	j	K	k	L	l	5		
6	M	m	N	n	O	o	6		
7	P	p	Q	q	R	r	S	s	7
8	T	t	U	u	V	v	8		
9	W	w	X	x	Y	y	Z	z	9
0	(space)	.	:	/	-	()	0	

- Note:**
- If you misdial, press  (Clear) to clear each digit from the last one, and enter the number again.
 - Use  or  to move the cursor to change or enter a character.

Using the Directory

For example, to enter “Tom Jones”:

1 Press **TUV8**.



2 Press **MNO6** six times.



3 Press **⇨** to move the cursor to the right.

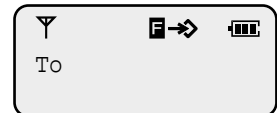

4 Press **MNO6** two times.

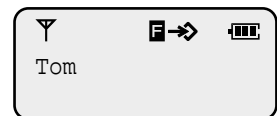

5 Press **↵** to enter a blank.



6 Press **JKL5**.

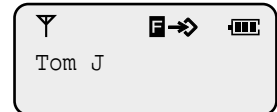

7 Press **MNO6** six times.



8 Press **⇨** to move the cursor to the right.



9 Press **MNO6** four times.



10 Press **DEF3** four times.



11 Press **PQRS7** eight times.

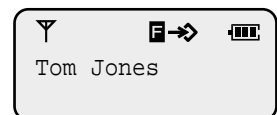

Key Operations

The following buttons can be activated by display operations.

Pause Button
FWD/DND Button
Message Button
Conference Button
Tone Button

These buttons can also be activated using a combination of buttons.

For descriptions and button combinations, refer to page 4.

For operations where the buttons are used, refer to the “DPT Features” in the KX-TD816 / KX-TD1232 User Manual.



1 Press  (Function).

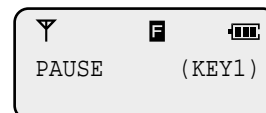

2 Press  (OK).



3 Press  (Book) repeatedly until the desired button is displayed.

- You can also search by pressing  (Next) or  (Previous).

Example

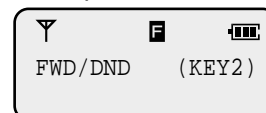

4 Press  (OK).



5 Continue with the required operations.

Other Operations

Most of the features described in the User Manual for the model KX-TD816 / KX-TD1232 are supported by a system with a DECT portable station (PS).

However, there are some exceptions and advanced feature as listed below.

NEWLY SUPPORTED FEATURE	NOT SUPPORTED FEATURES
Super Extra Device Port (SXDP) – Refer to page 41.	Background Music (BGM) Executive Busy Override – CO Line EXtra Device Port (XDP) Handsfree Operation – PS is not provided with a built-in speaker. Live Call Screening (LCS) Log-In / Log-Out Microphone Mute Off-Hook Monitor Paging – Deny Paralleled Telephone (PT and SLT) Phantom Extension Redial, Automatic Operator Service Features Ring Group Uniform Call Distribution (UCD)

- Note:**
- For more details, please refer to the User Manual for the model KX-TD816 / KX-TD1232.
 - For buttons which are not provided with the PS, refer to the Key Operation or PBX Programming.
 - While on-hook status, the LED (Light Emitting Diode) button indicators do not work.
 - The PS may not show complete displays like other PTs with displays.
 - In the operation procedure, note the expressions shown below.
- Off-Hook :** Press the **Talk** button.
- On-Hook :** Press the **Talk** or **Cancel** button.

Other Operations

■ Absent Message Capability

There are nine flexible absent messages available. If you select a message, it will be shown on the display of the calling party's telephone. If required, messages 7, 8 and 9 can be assigned by System Programming. For System Programming, refer to the KX-TD816/KX-TD1232 Installation Manual.

Setting

- Off-hook.
- Dial **750**.
- Dial a **message number** (1-9) + **parameter** (such as an extension number, if required).
 - **1** : "Will Return Soon"
 - **2** : "Gone Home"
 - **3** + **extension number** :
"At Ext (extension number)"
 - **4** + **hour** (00-23) + **minute** (00-59) :
"Back at (time)"
 - **5** + **month** (01-12) + **day** (01-31) :
"Out Until (date)"
 - **6** : "In a Meeting"
 - **7-9** : User programmable messages
- On-hook.

Canceling

- Off-hook.
- Dial **7500**.
- On-hook.

■ Account Code Entry

Used to identify outside calls, for accounting and billing purposes. If required, you may be forced to enter account code before dialing.

Entering before dialing

- Off-hook.
- Dial **49** (or press the Account button).
- Enter the **account code** (up to five digits) + #.

Entering during or after a conversation

During a conversation or while hearing a reorder tone after the other party hangs up

- Dial **49** (or press the Account button).
- Enter the **account code** + #.

■ Alternate Calling — Ring/Voice

You can select ring or voice calling when making an intercom call to a proprietary telephone (PT) user. In the Voice-Calling mode, you can announce to the other party immediately after the confirmation tone.

If the called extension has set the Ring-Calling mode;

- Press *****, when hearing the ringback tone.
— A confirmation tone is audible.
(The Voice-Calling mode is active.)

If the called extension has set the Voice-Calling mode;

- Press *****, when hearing the confirmation tone.
— A confirmation tone is audible.
(The Ring-Calling mode is active.)

■ Answering, Direct CO Line

You can answer an outside call by simply pressing a CO button.

- Press the **CO** button (flashing red rapidly).

■ Automatic Callback Busy (Camp-On)

When the selected CO line or extension you have dialed is busy, dial the camp-on code and hang up. Your PS will ring when the selected CO line or called party becomes idle. When you answer the callback, the called extension automatically starts ringing or the CO line is automatically selected to make an outside call.

Setting

While hearing a busy tone

- Dial **6**.
— A confirmation tone is audible.
- On-hook.

Answering an intercom recall

- Off-hook.

Answering a CO line recall

- Off-hook.
- Dial the **phone number**.

Other Operations

Canceling

- Off-hook.
- Dial **46**.
- On-hook.

■ Busy Station Signaling (BSS)

You can inform a busy extension, which has set Call Waiting, that you are waiting. The extension will hear three beeps.

While hearing a busy tone

- Dial **1**.
- Wait for an answer.

■ Call Forwarding

Automatically transfers incoming calls to another extension or to an external destination. The following types are available:

All Calls

All calls are forwarded to another extension.

Busy

Calls are forwarded to another extension when your extension is busy.

No Answer

Calls are forwarded to another extension if you don't answer the call.

Busy/No Answer

Calls are forwarded to another extension if your extension is busy or you don't answer.

to CO Line

Calls are forwarded to a CO line.

Follow Me

You can remotely set Call Forwarding – All Calls from another extension.

Setting

- Off-hook.
- Dial **710** (or press the FWD/DND button).

- Dial as follows:

- **2 + extension number** : All Calls
- **3 + extension number** : Busy
- **4 + extension number** : No Answer
- **5 + extension number** : Busy/No Answer
- **6 + line access code (9, 81-88) + phone number + #** : to CO Line
- **7 + your extension number** : Follow Me

- On-hook.

Canceling

- *At the original extension*

- Off-hook.
- Dial **710** (or press the FWD/DND button).
- Dial **0**.
- On-hook.
- *At the destination extension — “Follow Me (All Calls)” only*
- Off-hook.
- Dial **710** (or press the FWD/DND button).
- Dial **8 + your extension number**.
- On-hook.

■ Call Hold, Retrieve

You can retrieve a call which has been placed on hold by another extension.

Retrieving an outside call on hold

- *at another extension*
- Press the **CO** button (flashing red slowly).

Retrieving an intercom call on hold

- *at another extension*
- Dial **51** + the holding **extension number**.

Other Operations

■ Calling/Connected Line Identification Presentation (CLIP/COLP)

Allows you to display your number on the LCD of the called party's telephone when making a call (CLIP), or allows you to display your number on the LCD of the calling party's telephone when answering a call (COLP) through an ISDN line.

To select a CLIP/COLP number for an outside line

- Off-hook.
- Dial **7111**.
- On-hook.

To select a CLIP/COLP number for an extension

- Off-hook.
- Dial **7112**.
- On-hook.

■ Call Park

You can place a held call into a system parking area so that any other extension user can retrieve it.

Setting

During a conversation

- Press the **Transfer** button.
— A confirmation tone is audible.
- Dial **52 + parking zone number** (0 through 9).
— A confirmation tone is audible.
- On-hook.

Retrieving

- Off-hook.
- Dial **52 + the parking zone number**.

■ Call Pickup, CO Line

You can answer an incoming outside call ringing at another extension.

- Off-hook.
- Dial **4***.

■ Call Pickup, Directed

You can answer an incoming call ringing at any other extension.

- Off-hook.
- Dial **41 + the extension number**.

■ Call Pickup, Group

You can answer an incoming call ringing at another extension within your extension group.

- Off-hook.
- Dial **40**.

■ Call Pickup Deny

You can prevent another extension from picking up your calls.

Setting / Canceling

- Off-hook.
- Dial **720**.
- Dial **1** or **0**.
 - **1** : to set
 - **0** : to cancel
- A confirmation tone is audible.
- On-hook.

Other Operations

■ Call Splitting

You can have a two callers on a line and alternate between them.

During a conversation while holding another call

- Press the **CO** or **INT'** button (flashing red moderately).
- (Pressing this button alternates between the callers.)

During a conversation with an intercom call while holding another intercom call

- Press **Hold** button.
- (Pressing this button alternates between the callers.)

■ Call Transfer – to CO Line

You can transfer a call to a CO line.

During a conversation

- Press the **Transfer** button.
- Press the **CO** button.
- Dial the **phone number**.
- Wait for an answer and announce.
- On-hook.

■ Call Transfer – to Extension

You can transfer a call to another extension (screened or unscreened).

Screened Call Transfer

During a conversation

- Press the **Transfer** button.
- Dial the **extension number**.
- Wait for an answer and announce.
- On-hook.

Unscreened Call Transfer

During a conversation

- Press the **Transfer** button.
- Dial the **extension number**.
- On-hook.

■ Call Waiting

Informs you with three beeps that there is a call waiting.

Setting / Canceling

- Off-hook.
- Dial **731**.
- Dial **1** or **0**.
 - **1** : to set
 - **0** : to cancel
- A confirmation tone is audible.
- On-hook.

To talk to the new caller, terminate the current call

While hearing a Call Waiting tone

- Press the **CO** or **INT'** button.

To talk to the new caller, hold the current call

While hearing a Call Waiting tone

- Press the **Hold** button.
- (Press the **CO** or **INT'** button.)

■ Conference

You can make a three-party conversation.

During a conversation

- Press the **Conference** button.
- Dial the **third party**.
- Talk to the third party.
- Press the **Conference** button.

■ Conference, Unattended

You can leave a three-party conversation with two other outside parties and let them continue their conversation.

During a conversation with two outside parties

- Press the **Conference** button.

Other Operations

■ Data Line Security

Your extension is protected against interruption from the “Call Waiting,” “Hold Recall,” and “Executive Busy Override” features.

Setting / Canceling

- Off-hook.
 - Dial **730**.
 - Dial **1** or **0**.
 - **1** : to set
 - **0** : to cancel
- A confirmation tone is audible.
- On-hook.

■ Direct Inward System Access (DISA)

Allows a CO caller to access specific system features as if the caller is an extension in the system. The DISA outgoing message is used to give CO callers assistance with things such as listing the extension numbers in the system.

■ Display Call Information

You can alternate the display (the meter, phone number, phone charge) during a conversation with an outside party.

- Press the **FWD/DND** button.

■ Do Not Disturb (DND)

You can prevent other parties from disturbing you. The extension will not receive calls and the call may be transferred to a backup extension.

Setting

- Off-hook.
 - Dial **710** (or press the FWD/DND button).
 - Dial **1**.
- A confirmation tone is audible.
- On-hook.

Canceling

- Off-hook.
- Dial **710** (or press the FWD/DND button).
- Dial **0**.
 - A confirmation tone is audible.
- On-hook.

■ Do Not Disturb Override

You can call an extension even though Do Not Disturb is set.

- Dial **1** while hearing the Do Not Disturb tone.

■ Doorphone Call

You can answer or make a doorphone call. Moreover, you can unlock the door.

Answering a doorphone call

- Off-hook.

Calling a doorphone

- Off-hook.
- Dial **31**.
- Dial the **doorphone number** as follows.
 - 1 or 2 : if connected to a KX-TD816
 - 1 through 4 : if connected to a KX-TD1232

To unlock the door (programmed extensions only)

- Off-hook.
 - Dial **55**.
 - Dial the **doorphone number** as follows.
 - 1 or 2 : if connected to a KX-TD816
 - 1 through 4 : if connected to a KX-TD1232
- A confirmation tone is audible.
- On-hook.

To unlock the door while talking to the doorphone

- Dial **5**.
- A confirmation tone is audible.
- On-hook.

Other Operations

■ Electronic Station Lockout

You can lock your extension so that other users cannot make outside calls at your extension.

Locking

- Off-hook.
- Dial **77** + the **lock code** (000 through 999).
- Dial the **same lock code** again.
— A confirmation tone is audible.
- On-hook.

Unlocking

- Off-hook.
- Dial **77** + the **lock code**.
— A confirmation tone is audible.
- On-hook.

■ Emergency Call

You can make an emergency call without dial restrictions. You can store up to ten emergency numbers by System Programming. For System Programming, refer to the KX-TD816/KX-TD1232 Installation Manual.

- Off-hook.
- Press the **CO** button.
- Dial the desired **emergency number**.

■ Executive Busy Override – Extension

You can enter into an existing extension conversation.

When the line is busy

- Dial **2**.

■ Executive Busy Override Deny

You can prevent other extension users from interrupting your conversation.

Setting / Canceling

- Off-hook.
- Dial **733**.
- Dial **1** or **0**.
 - **1** : to set
 - **0** : to cancel
- A confirmation tone is audible.
- On-hook.

■ External Feature Access

Allows you to access special features (e.g. Call Waiting) offered by a PBX, or Central Office.

During a conversation

- Press the **Flash** button.
- Dial the desired **service code**.

■ Full One-Touch Dialing

You can make a call or access a system feature with the touch of a button.

- Press an **One-Touch Dialing** or **DSS** button.

■ Message Waiting

You can leave a message notification for another extension. For PS users, “” is displayed as notification.

Setting / Canceling

- Off-hook.
- Dial **70**.
- Dial **1** or **0**.
 - **1** : to set
 - **0** : to cancel
- Dial the **extension number**.
— A confirmation tone is audible.
- On-hook.

Other Operations

Setting when the extension is busy

- Dial **4** (or press the Message button).
— A confirmation tone is audible.
- On-hook.

Calling back the message sender

- Off-hook.
- Dial **702** (or press the Message button).

Clearing all messages by the message receiver

- Off-hook.
- Dial **700** + your extension number.

Note

You cannot check or select a message notification sender. You can only call back the sender in the order the notification were left.

■ One-Touch Dialing

You can make a call or access a system feature with a touch of a button after going off-hook.

- Off-hook.
- Press an **One-Touch Dialing** button.

■ Operator Call

You can call an operator. A general call does not specify the operator, while a specific call does.

General Call

- Off-hook.
- Dial **0**.

■ Paging

You can announce (page) through the built-in speaker of the wired telephone or by the external speakers.

All

You can page using both the built-in speakers and external pagers.

External

You can page using all of the external pagers simultaneously or using a specific external pager.

Group

You can page all groups (all wired extensions) simultaneously or a particular group of wired extensions using the built-in speakers.

All

- Off-hook.
- Dial **32** (or **33**) + * .
— A confirmation tone is audible (optional).
- Announce.

External

– To access all external pagers

- Off-hook.
- Dial **320**.
— A confirmation tone is audible (optional).
- Announce.

– To access a particular pager only

- Off-hook.
- Dial **32**.
- Dial the **external pager number** as follows.
 - 1 : if connected to a KX-TD816
 - 1 – 4 : if connected to a KX-TD1232
- A confirmation tone is audible (optional).
- Announce.

Other Operations

Group

- **To access all groups simultaneously**
 - Off-hook.
 - Dial **33 + 0**.
 - A confirmation tone is audible (optional).
 - Announce.
- **To access a particular group of extensions**
 - Off-hook.
 - Dial **33 + extension group number** (1 through 8).
 - A confirmation tone is audible (optional).
 - Announce.

■ Paging – ANSWER

You can answer a page which is being announced over a nearby proprietary wired telephone or external pager. However, you cannot be directly paged at the PS.

- Off-hook.
- Dial **42 + external pager number, or 43**.
 - **42 + external pager number** :
To answer a “Paging – External”
 - **43** : To answer a “Paging – Group” in the same extension group

■ Paging and Transfer

You can transfer a call to the paged person.

- Press the **Transfer** button before dialing the **paging feature number** (32 or 33).
 - Check the feature number you wish to use in the “Paging” section.

■ Pickup Dialing (Hot Line)

You can make a call by simply going off-hook.

Programming the phone number

- Off-hook.
- Dial **742 + the phone number + #**.
 - A confirmation tone is audible.
- On-hook.

Setting / Canceling

- Off-hook.
- Dial **74**.
- Dial **1 or 0**.
 - **1** : to set
 - **0** : to cancel
- A confirmation tone is audible.
- On-hook.

Dialing

- Off-hook.

■ Pulse to Tone Conversion

You can change from the Pulse to Tone dialling mode.

- Dial the **phone number** (Pulse mode).
- Select the Tone button (or dial *** + #**).
- Dial the **phone number** (Tone mode).

■ Redial, Last Number

You can redial the last dialed number.

- Off-hook.
- Dial **#**.

■ Redial, Saved Number

The desired outside call number can be stored and then redialed.

Storing

During a conversation or while hearing a busy tone

- Press the **Auto/OK** button.
- Press the **Save** button.

Dialing

- Off-hook.
- Press the **Save** button.

Other Operations

■ Station Feature Clear

You can reset all of the station features you programmed to their default settings.

- Off-hook.
- Dial **790**.
— A confirmation tone is audible.
- On-hook.

■ Station Speed Dialing

You can store up to ten speed dial numbers which can only be used by you.

Storing a phone number

- Off-hook.
- Dial **30** + the **station speed dial number** (0 through 9) + the **phone number** + #.
— A confirmation tone is audible.
- On-hook.

Dialing

- Off-hook.
- Dial **3*** + the **station speed dial number**.

■ Super EXtra Device Port (SXDP)

SXDP allows a PS to be used in parallel with a proprietary wired (PT) or single line telephone (SLT). When in the SXDP mode, incoming calls to a wired telephone also reach the paired PS, while incoming calls to a PS only reach the PS. If either paralleled telephone is busy, you cannot make a call from the other telephone. The memory of Call Log can be used with a PS and a paired telephone.

Setting

- Off-hook.
- Dial **481** + **wired extension number**.
— A confirmation tone is audible.
- On-hook.

Canceling

- Off-hook.
- Dial **480**.
— A confirmation tone is audible.
- On-hook.

■ System Speed Dialing

The system supports 500 speed dial numbers which are available to all extension users.

- Off-hook.
- Press the **Auto/OK** button.
- Dial the **system speed dial number** (000 through 499).

■ Timed Reminder

You can set an alarm once or everyday at a pre-set time as a wake up or reminder.

Setting

- Off-hook.
- Dial **761**.
- Enter **hour** (01 through 12).
- Enter **minute** (00 through 59).
- Dial **0** or **1**.
 - **0** : AM
 - **1** : PM
- Dial **0** or **1**.
 - **0** : for a one time setting
 - **1** : for a daily setting
- A confirmation tone is audible.
- On-hook.

Canceling

- Off-hook.
- Dial **760**.
— A confirmation tone is audible.
- On-hook.

Checking the setting time

- Off-hook.
- Dial **762**.

Other Operations

■ Trunk (CO Line) Answer From Any Station (TAFAS)

You can answer any page or ring sent to a ringer.

Answering the external pager

- Off-hook.
- Dial **42** + the **external pager number** as follows.
 - 1 : if connected to a KX-TD816
 - 1 - 4 : if connected to a KX-TD1232

■ Two-Way Recording into Voice Mail†

You can record a conversation into your mailbox or another mailbox, while talking on the phone.

Recording into your mailbox

- Press the **Two-Way Record** button.

Stopping recording into your mailbox

- Press the **Two-Way Record** button.

Recording into another mailbox

- Press the **Two-Way Transfer** button.
- Dial the **extension number** or press the desired **DSS** button.

Stopping recording into another mailbox

- Press the **Two-Way Transfer** button.

■ Voice Mail Integration

When you are busy or away from your desk, your calls can be forwarded to a mailbox in the Voice Processing System.

Setting Call Forwarding destination to Voice Mail (VM)

- Off-hook.
- Dial **710** (or press the FWD/DND button).
- Dial the **Call Forwarding number** (2 through 5).
 - **2** : Call Forwarding – All Calls
 - **3** : Call Forwarding – Busy
 - **4** : Call Forwarding – No Answer
 - **5** : Call Forwarding – Busy/No Answer
- Dial the **VM extension number**.
 - A confirmation tone is audible.
- On-hook.

Listening to a stored message

- Off-hook.
- Dial the **VM extension number** (or press the Message button).

■ Voice Mail Transfer

You can transfer outside calls to the Voice Processing System so that the caller can leave their message in the mailbox of the desired extension.

If you forward an outside call to an extension and the call is returned to you

- Press the **Voice Mail (VM) Transfer** button.
- Dial the **extension number**.

Programming Overview

There are three programming modes.
The list below shows the programming overview.

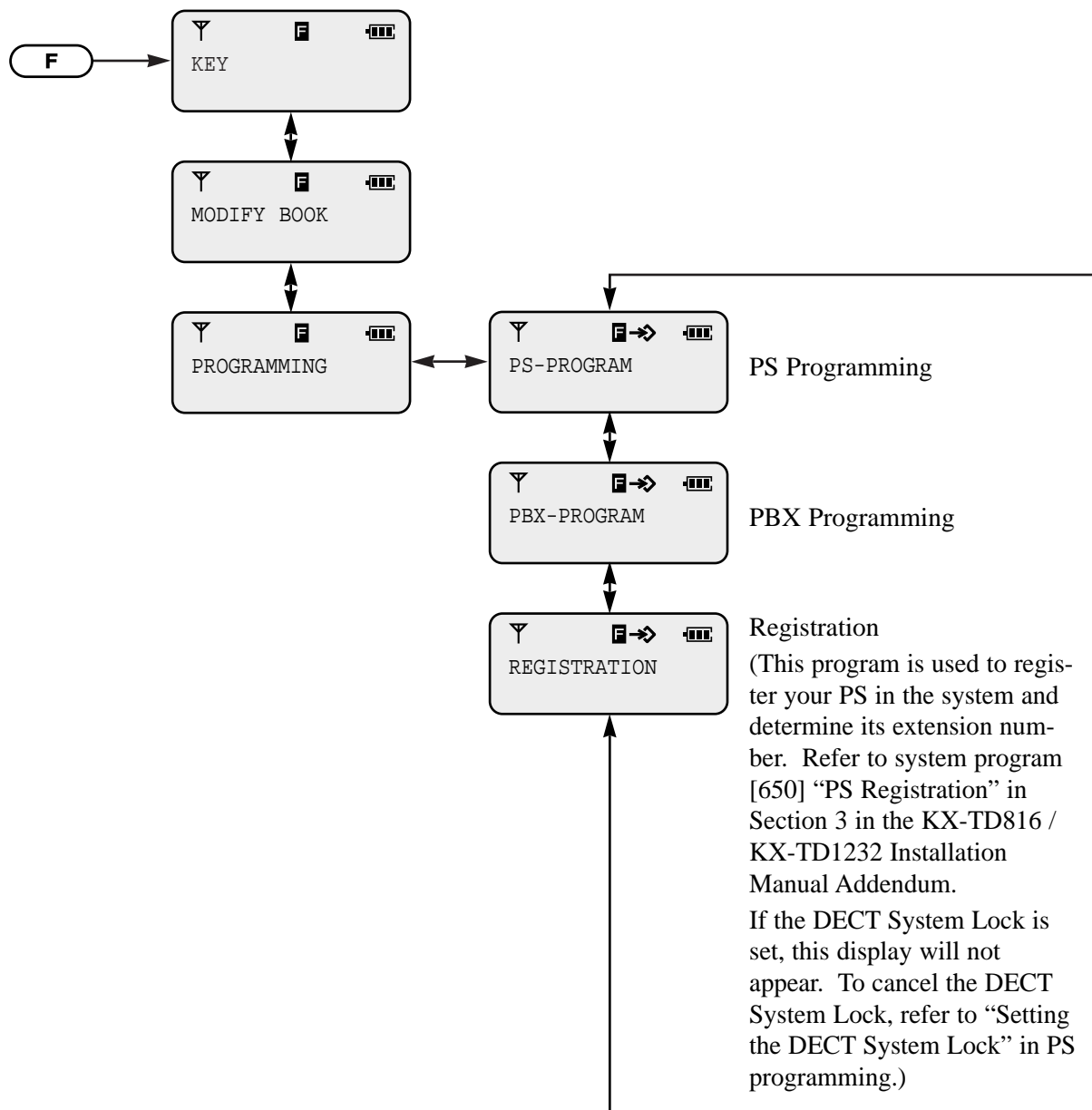

PS Programming

PS Programming Items Description

You can change the default settings or programming of your PS according to your needs.

You may be required to enter a PS Programming password or a DECT System Lock password when entering into the PS Programming mode.

PS Programming password: programmed in PS Programming.

DECT System Lock password: programmed in the initial PS registration or in PS Programming.

The PS Programming menu displayed differs depending on the password level as follows.

Level 0: A password is not required.

Level 1: A PS Programming password is required.

Level 2: A System Lock password is required.

The combination of the passwords are as follows.

System Lock	Disable	Disable	Enable	Enable
PS Programming	Disable	Enable	Disable	Enable
System Lock Password	—	—	Level 0 – 2	Level 0 – 2
PS Programming Password	—	Level 0 – 2	—	Level 0 – 1
No Password or Incorrect Password	Level 0 – 2	Level 0	Level 0 – 1	Level 0

PS Programming

The possible programming items and their password levels and displays are shown below in the order they are displayed.

Setting the Keypad Backlight Mode (Level 0)

You can turn off the keypad lights to save electricity.

(Default: ON)



Setting the Key Tone (Level 0)

You can select whether the button on your PS sounds a tone or not. If "ON" is selected, a key tone will be heard when you press a button (except during the PBX Programming mode).

(Default: ON)

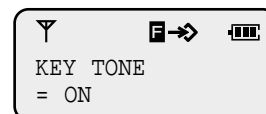

Selecting the Ringer Pattern (Level 0)

You can select the PS ringer pattern (6 patterns).

(Default: Ringer 1)

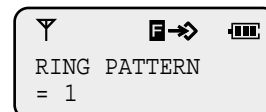

Selecting the Vibration and Ring Type (Level 0)

You can select the vibration and ring type; off, vibrate and ring simultaneously (RING & VIB), or vibrate for nine seconds and then ring (VIB→RING).

(Default: OFF)

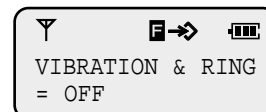

This program can be set in combination with the VOLUME Control button adjustment (page 11) as shown below.

		VOLUME Control Button Adjustment		
		RINGER (1 – 7)	RINGER OFF	VIBRATION
PS Prog.	OFF	RINGER	OFF	VIB
	RING & VIB	RINGER and VIB†	VIB	VIB
	VIB→RING	VIB for 9 sec and then RINGER	VIB for 9 sec	VIB

†: Battery life may decrease faster than the other settings.

PS Programming

Selecting the Display Language (Level 0)

You can select the display language; English, German, French, Italian, Spanish or Dutch.

(Default: AUTO [English])

If you are connected to a Panasonic Digital Super Hybrid System (DSHS) while the default setting is still “AUTO”, the display language will depend on the setting of the system.



Controlling the Directory Lock (Level 1)

You can lock (ON) or unlock (OFF) the PS Dialing Directory.

(Default: OFF)

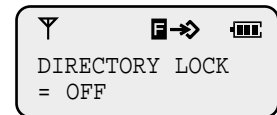

Setting the Quick Answering Mode (Level 0)

You can quickly answer an incoming call by just lifting your ringing PS off the Charger.

(Default: ON)

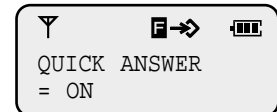

Setting the Automatic Answer Mode (Level 0)

You can answer all calls (INT/CO) or intercom calls (INT ONLY) without lifting your PS when using the headset.

(Default: OFF)

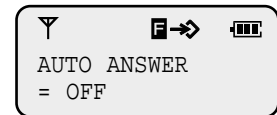

Selecting the Automatic Answer Delay (Level 0)

You can select the number of rings before answering calls automatically when using the headset. This program is displayed only when “Setting the Automatic Answer Mode” is set to “INT/CO” or “INT ONLY”.

(Default: 1RING)

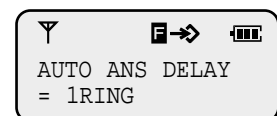

PS Programming

Selecting the DECT System (Level 2)

When the registration of your PS is completed, this program is automatically set to the registered DECT system (DECT-SYS1 through DECT-SYS4). If you want your PS to access all connected terminals automatically, select AUTO in this program. After changing the selection, it may take a few seconds to complete the setting. This program is only displayed when more than two fixed terminals are connected.

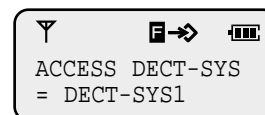

Selecting the Standby Display*¹ (Level 0)

You can select the number, extension number (EXT), DECT system number (DECT-SYS-NO.), or DECT system and extension number (DECT-SYS-NO.&EXT), which is displayed in the standby mode. You can also select not to display any of these numbers (OFF).
(Default: OFF)

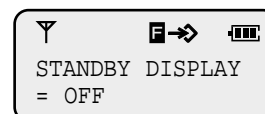

Selecting the Date / Time Display*¹ (Level 0)

You can select showing only the date (DATE) or date and time (TIME) in the standby mode display.
(Default: TIME)

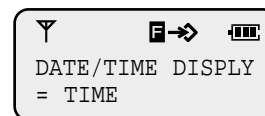

Clearing the Settings in Memory (Level 1)

All of the following settings can be returned to their default settings at one time.

- Call log numbers*²
- Ringer volume
- Receiver volume
- PS Programming items

(except: Selecting the DECT System;
Canceling the PS Registration;
Setting the PS Programming Password;
Setting the DECT System Lock)

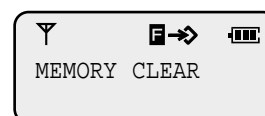

*¹: Only displayed when registered to a Panasonic Digital Super Hybrid System and “ Ψ ” is displayed.

*²: Only cleared when registered to a system other than a Panasonic Digital Super Hybrid System.

PS Programming

Canceling the PS Registration (Level 2)

To cancel your PS registration, use the system program [651], "PS Termination". If "Rejected" or "Time Out" is displayed in program [651], delete the PS again by PS programming. It may take a few seconds to complete the cancelation.

Refer to System Programming in the Installation Addendum for program [651].

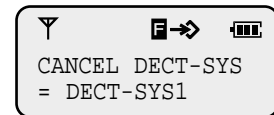

Setting the Guidance Menu (Level 0)

You can enable the guidance menu. This will show the selectable keys, and helps you operate the PS without the operating manual. (Default: OFF)



Guidance Menu	
BOOK ()=NEXT	* ()=PREV
OK ()=OK	HOLD ()=BACK
# ()=NEXT	C ()=EXIT

Setting the PS Programming Password (Level 1)

You can set the PS Programming password. In this case, you must enter your password in order to display the following programs.

- Controlling the directory lock
 - Clearing the settings in memory
 - Setting the PS programming password
- (Default: DISABLE)

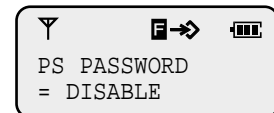

Setting the DECT System Lock (Level 2)

You can enable or disable the DECT System Lock. If enabled, you must enter your password when entering the PS Programming mode in order to display the following programs.

- Selecting the DECT system
 - Canceling the PS registration
 - Setting the DECT system lock
- (Default: DISABLE)

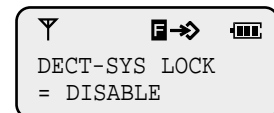

PS Programming

PS Programming Operations

Make sure the Power Switch is set to ON (●).



PS Programming (– except for Setting the PS Programming Password)

Note: – A PS Programming password or DECT System Lock password may be required after step 4.

1 Press  (Function).



2 Press  (Book) 2 times.

- You can also search by pressing  (Next) or  (Previous).

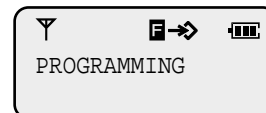

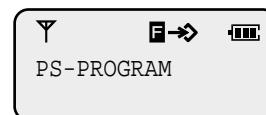

3 Press  (OK).





4 Press  (OK).

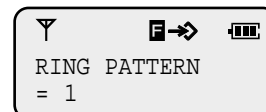

5 Press  (Next) or  (Previous) repeatedly until the desired program item is displayed.

Example



6 Press  (Book) repeatedly until the desired selection is displayed.

Example

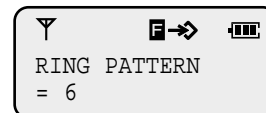

- **This step is not necessary** for clearing settings in memory.

7 Press  (OK).

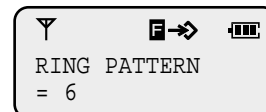

8 Repeat steps 5 through 7 if you want to program other items.

9 To exit the PS Programming mode, press  (Cancel).

PS Programming

Setting the PS Programming Password / DECT System Lock Password

1 Search the PS Password or DECT System Lock display. (Refer to steps 1 through 6 on page 49).

Example



2 Press  (Book) to select ENABLE.



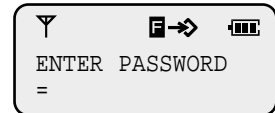

3 Press  (OK).

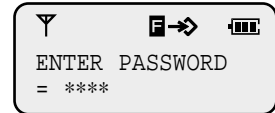

4 Enter the **password** (4 digits).

Example



5 Press  (OK).

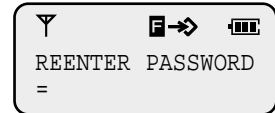

6 Enter the **same password** again.

Example





7 Press  (OK).

8 To exit the PS Programming mode, press  (Cancel).

PS Programming

Canceling the PS Programming Password / DECT System Lock Password

- 1** Search the PS Password or DECT System Lock display. (Refer to steps 1 through 6 on page 49).
- 2** Press  (Book) to select DISABLE.
- 3** Press  (OK).
- 4** To exit the PS Programming mode, press  (Cancel).

Example



PBX Programming

PBX Programming Overview

You can enter into the proprietary wired telephone (PT) programming mode and program several items for your PS. However, some items may not be supported depending on your system. For more details, refer to Station Programming in the KX-TD816 / KX-TD1232 User Manual.

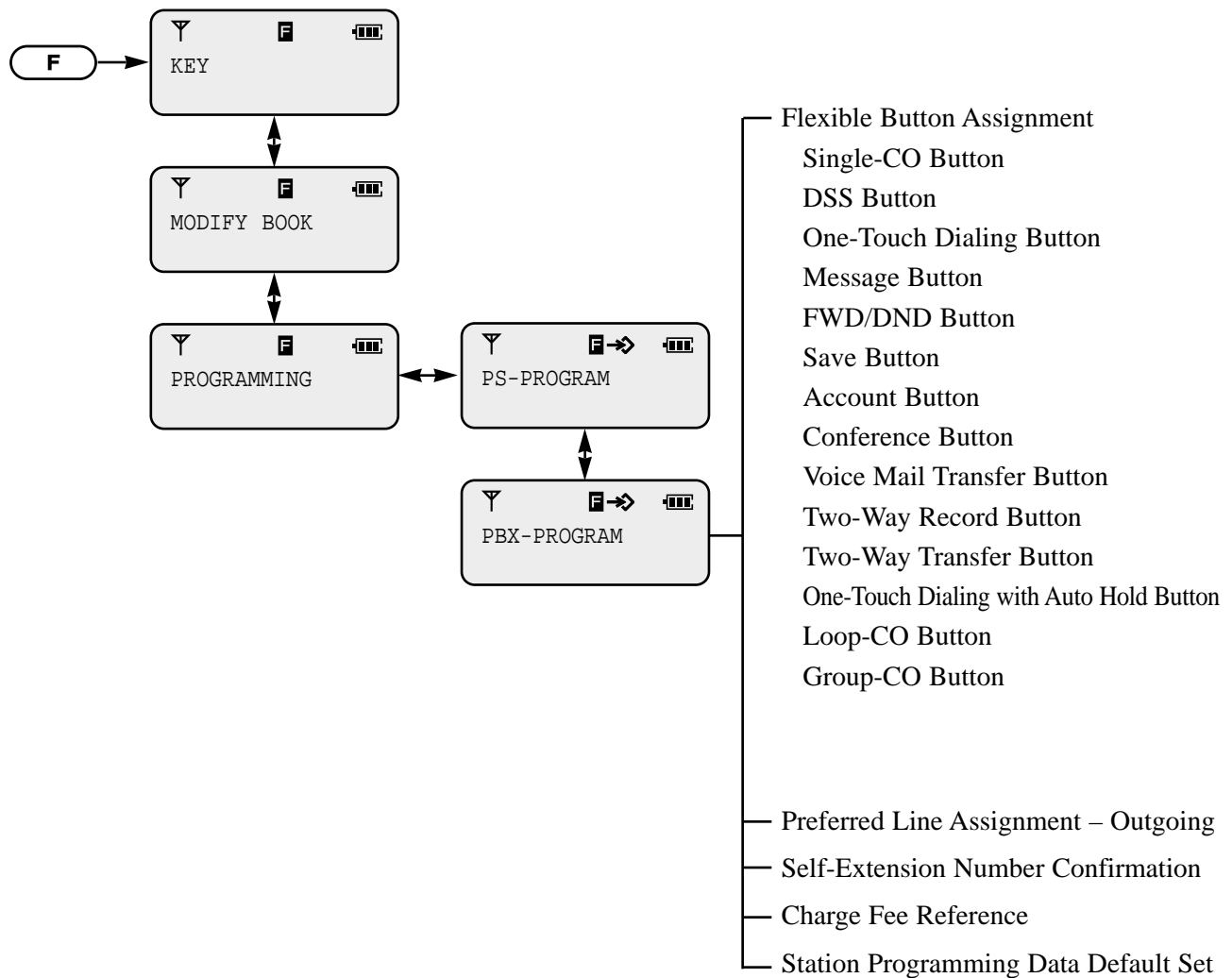



Note: – The LED does not work when a flexible button is assigned other than a Single-CO, DSS, Loop-CO or Group-CO button.





PBX Programming



PBX Programming Operations





Make sure the Power Switch is set to ON (●) and “Y” is displayed.



- 1** Press  (Function).



- 2** Press  (Book) 2 times.





 - You can also search by pressing  (Next) or  (Previous).
- 3** Press  (OK).

- 4** Press  (Book).



 - You can also search by pressing  (Next) or  (Previous).
- 5** Press  (OK).

 - The  (Intercom) flashes green.
- 6** Program the desired PBX Programming items. For more details, refer to Station Programming in the KX-TD816 / KX-TD1232 User Manual.
- 7** To exit the PBX Programming mode, press  (Cancel).





Note: – The following PS buttons replace the buttons of the proprietary telephone (PT) shown in Station Programming in the KX-TD816 / KX-TD1232 User Manual.
Exception: Charge Fee Reference – All Clear;
 Use  (Book) instead of the NEXT (S3) button in step 4.

PT Button	PS Button
CLR (S2)	=  (Clear)
NEXT (S3)	= Not supported.
PREV	=  (Redial)
STORE	=  (OK)
HOLD	=  (Hold)

Before Requesting Help

PROBLEM	REMEDY OR SOURCE OF TROUBLE
The PS does not work.	<ul style="list-style-type: none"> • The battery is empty. Charge the batteries fully (p. 9). • The PS has been canceled or the PS has not been registered. To register the PS, refer to system program [650], “PS Registration”, in the Installation Manual Addendum for the KX-TD144/KX-TD142/KX-TD7500.
The PS does not operate.	<ul style="list-style-type: none"> • The power switch is OFF (○). Turn it ON (●).
The PS does not ring.	<ul style="list-style-type: none"> • Ringer volume is set to OFF or VIBRATION. • The PS is out of range or the Cell Station (CS) is busy. • The radio channel is busy or radio communication error occurs. Try again later.
You cannot dial.	<ul style="list-style-type: none"> • The number which you dialed is restricted by the system. • The key lock mode is set. To cancel the mode, see page 19. • The radio channel is busy or radio communication error occurs. Try again later.
Static, sound cuts in/out, fades. Interference from other electrical units.	<ul style="list-style-type: none"> • Set the PS and CS away from other electrical appliances. • Move closer to the CS.
“CS Busy” is displayed.	<ul style="list-style-type: none"> • The Cell Station is busy. Try again later.
“PS NO CONNECTED” is displayed.	<ul style="list-style-type: none"> • The power switch is set to OFF. • The PS is out of range. • The radio channel is busy or radio communication error occurs. Try again later.
You cannot store a phone number and name in the directory.	<ul style="list-style-type: none"> • Your entry exceeds the maximum digits or characters. • Do not pause for over 30 seconds while programming.
The alarm sounds after pressing  (Redial).	<ul style="list-style-type: none"> • No number is saved in the Call Log.
“  ” flashes or beeps tones sound every 5 seconds during a conversation.	<ul style="list-style-type: none"> • The battery is low. Charge the batteries fully (p. 9).

Before Requesting Help

PROBLEM	REMEDY OR SOURCE OF TROUBLE
You charged the batteries fully, but “  ” flashes.	<ul style="list-style-type: none"> • Clean the charge contacts and charge again. • It is time to change the batteries. Please purchase new batteries.
The PS stops working during operation.	<ul style="list-style-type: none"> • Turn the power switch OFF (○) and ON (●). Then try again. • Re-insert the battery and try again.
Handover does not work.	<ul style="list-style-type: none"> • You moved to a busy CS or are out of range. • You moved while not having a conversation (e.g., while hearing a busy tone). • The radio channel is busy or radio communication error occurs.
The display does not show a strong radio signal “  ” even though you are near the CS.	<ul style="list-style-type: none"> • The PS user can make a call normally even in the “” status. In this case, the current linked CS is still connected even though the other CS is closer.
The alarm sounds during a conversation while receiving a weak radio signal “  ”.	<ul style="list-style-type: none"> • The radio signal is weak. Move closer to the CS.

Safety Instructions

Take special care to follow the safety suggestions listed below.

Safety

- 1) Power Source: The Charger should be connected to a power supply only of the type described in the operating instructions or as marked on the Charger.
- 2) Non use Periods: When the portable station (PS) is not being used, turn the power off. When left unused for a long period of time, the Charger should be unplugged from the household AC outlet.

Installation

Environment

- 1) Water and Moisture: Do not use this PS and the Charger near water – for example, near a bath tub, washbowl, sink, etc. Damp basements should also be avoided.
- 2) Heat: The PS and the Charger should be kept away from heat sources such as radiators, kitchen ranges, etc. It also should not be placed in rooms where the temperature is less than 5°C (41°F) or greater than 40°C (104°F).

Placement

- 1) Stacking: Do not place heavy objects on top of the PS and Charger.
- 2) Foreign Material: Care should be taken so that objects do not fall onto and liquids are not spilled into the PS and Charger. Do not subject the PS and Charger to excessive smoke, dust, mechanical vibration, or shock.
- 3) Surface: Place the Charger on a flat surface.

Battery

To reduce the risk of fire or injury to persons, read and follow these instructions.

- 1) Use only the battery specified.
- 2) Do not dispose of the battery in a fire. It may explode. Check with local waste management codes for special disposal instructions.
- 3) Do not open or mutilate the battery. Released electrolyte is corrosive and may cause burns or injury to the eyes or skin. The electrolyte may be toxic if swallowed.
- 4) Exercise care in handling the battery in order not to short the battery to conductive materials such as rings, bracelets, and keys. The battery and/or conductor may overheat and cause burns.
- 5) Do not recharge batteries, which are provided or specified as replacement part for use with other products. The battery may leak corrosive electrolyte or explode.
- 6) Do not attempt to rejuvenate the battery provided with or identified for use with this product by heating. Sudden release of battery electrolyte may occur causing burns or irritation to eyes or skin.
- 7) Remove the battery from this product if the product will not be used for a long period of time (several months or more). During this time the battery could leak in the product.
- 8) Discard the “dead” battery as soon as possible. The “dead” battery may leak in the product.
- 9) Do not store this product, or the battery provided with or identified for use with this product, in high temperature areas. Batteries that are stored in a freezer or refrigerator for the purpose of extending shelf life should be protected from condensation during storage and defrosting. Batteries should be stabilized at room temperature prior to use after cold storage.

Safety Instructions

For Best Performance

Operating Range

- 1) The range of operation depends on the topography of your office, weather or usage conditions, because signals are transmitted between the Cell Station (CS) and the portable station (PS) by radio waves.
- 2) Normally, you get greater range outdoors than indoors. If there are obstacles such as walls, noise may interfere with your telephone calls. In particular, high metal shelves or reinforced concrete walls will shorten your operating range.
- 3) A PS may not work if used in places that are too far from the CS depending on the structure of the building.

Noise

Occasional noise or interference may occur due to other sources of electromagnetic radiation, such as refrigerators, microwave ovens, faxes, TVs, radios, or personal computer.

If noise affects your telephone calls, keep the PS away from other electrical appliances.

WARNING:

TO PREVENT FIRE OR SHOCK HAZARD, DO NOT EXPOSE THIS PRODUCT TO RAIN OR ANY TYPE OF MOISTURE.

This PBX fulfills the requirements of following European Regulations:



73/23/EEC "Low Voltage Directive"
89/336/EEC "Electromagnetic compability" (Basic EMC Publication)
92/31/EEC "Electromagnetic compability" (Supplement)
93/68/EEC "CE mark"

For above mentioned standards, the unit is signed with the CE-mark.

Any technical details given in these instructions are subject to change without notice.

Free Manuals Download Website

<http://myh66.com>

<http://usermanuals.us>

<http://www.somanuals.com>

<http://www.4manuals.cc>

<http://www.manual-lib.com>

<http://www.404manual.com>

<http://www.luxmanual.com>

<http://aubethermostatmanual.com>

Golf course search by state

<http://golfingnear.com>

Email search by domain

<http://emailbydomain.com>

Auto manuals search

<http://auto.somanuals.com>

TV manuals search

<http://tv.somanuals.com>