

Service Manual

Cordless Impact Driver

Model No. EY7542

North America

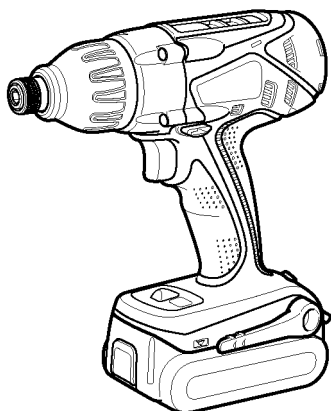

⚠ WARNING

This service information is designed for experienced repair technicians only and is not designed for use by the general public. It does not contain warnings or cautions to advise non-technical individuals of potential dangers in attempting to service a product. Products powered by electricity should be serviced or repaired only by experienced professional technicians. Any attempt to service or repair the product or products dealt with in this service information by anyone else could result in serious injury or death.

IMPORTANT SAFETY NOTICE

There are special components used in this equipment which are important for safety. These parts are marked by **⚠** in the Schematic Diagrams, Circuit Board Diagrams, Exploded Views and Replacement Parts List. It is essential that these critical parts should be replaced with manufacturer's specified parts to prevent shock, fire or other hazards. Do not modify the original design without permission of manufacturer.

TABLE OF CONTENTS

	PAGE	PAGE
1 Warning -----	2	
2 Specifications -----	2	
3 Troubleshooting Guide -----	3	
4 Disassembly and Assembly Instructions -----	5	
5 Wiring Connection Diagram -----	13	
6 Schematic Diagram -----	13	
7 Exploded View and Replacement Parts List -----	14	

Panasonic[®]

© 2007 Matsushita Electric Works, Ltd. All rights reserved. Unauthorized copying and distribution is a violation of law.

1 Warning

Caution:

- Pb free solder has a higher melting point than standard solder; Typically the melting point is 50 - 70°F (30 - 40°C) higher. Please use a soldering iron with temperature control and adjust it to 750 ± 20°F (400 ± 10°C). In case of using high temperature soldering iron, please be careful not to heat too long.
- Pb free solder will tend to splash when heated too high (about 1100°F / 600°C).

2 Specifications

MAIN UNIT

Motor		14.4V DC
No load speed	Impact mode	0-2350 min ⁻¹ (rpm)
	Drill driver mode	0-700 min ⁻¹ (rpm)
Maximum torque	Impact mode	140Nm (1430kgf-cm, 1239in-lbs.)
	Drill driver mode	14Nm (143kgf-cm, 124in-lbs.)
Clutch torque		Approx. 0.7Nm (7kgf-cm, 6.2in-lbs.) - 4.4Nm (45kgf-cm, 39in-lbs.)
Overall length		193mm (7-1/2")
Weight (with battery pack EY9L40)		1.65kg (3.61lbs.)

3 Troubleshooting Guide

(Refer to WIRING CONNECTION DIAGRAM)

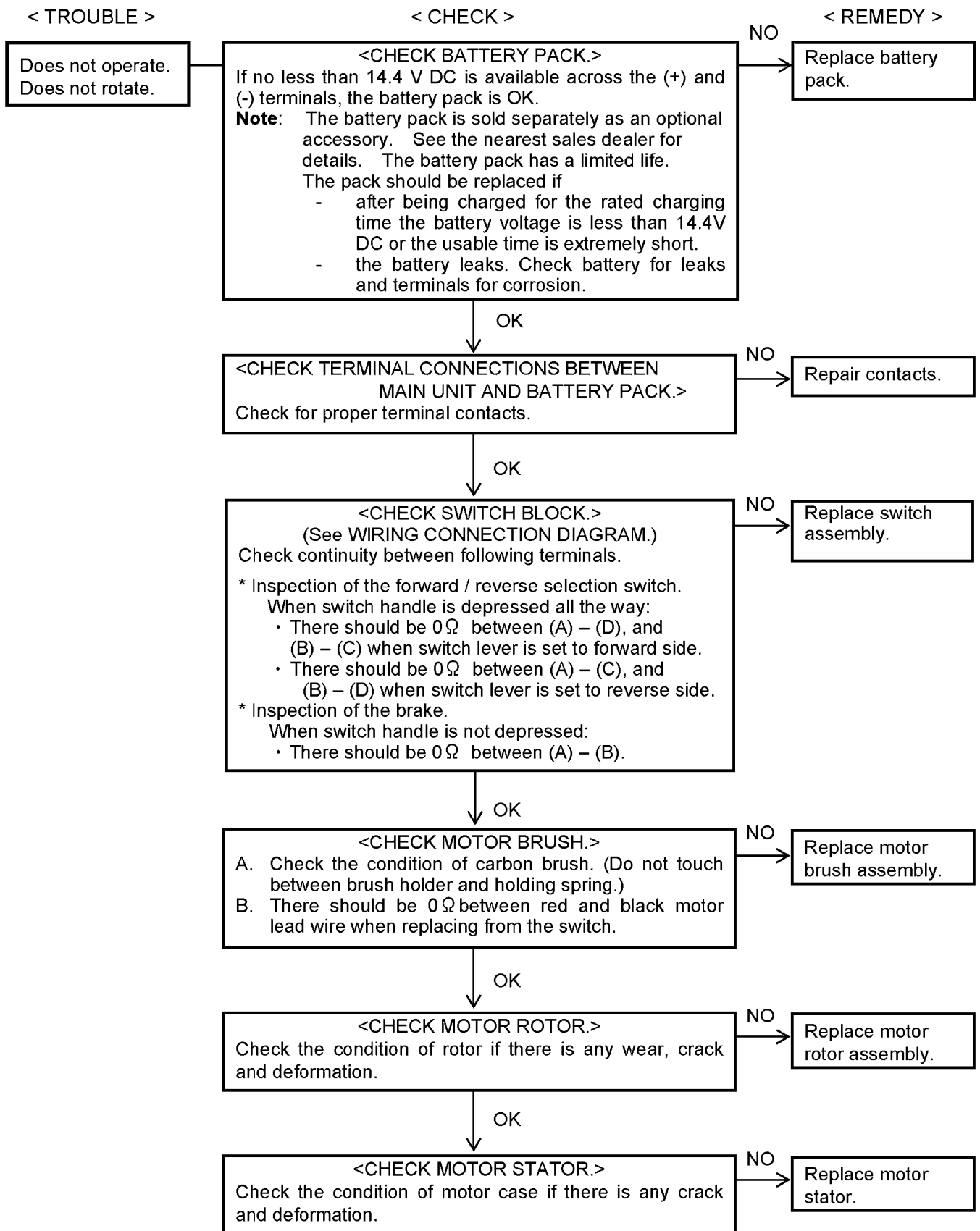

< TROUBLE >

< CHECK >

< REMEDY >

NOTE: Check battery pack and rotation speed before starting the following procedure.
Make sure if it is 0 ~2300rpm with the impact drive mode depressing the switch handle connecting DC14.4V by contact-current source. If it is not, check motor brush, rotor or stator.

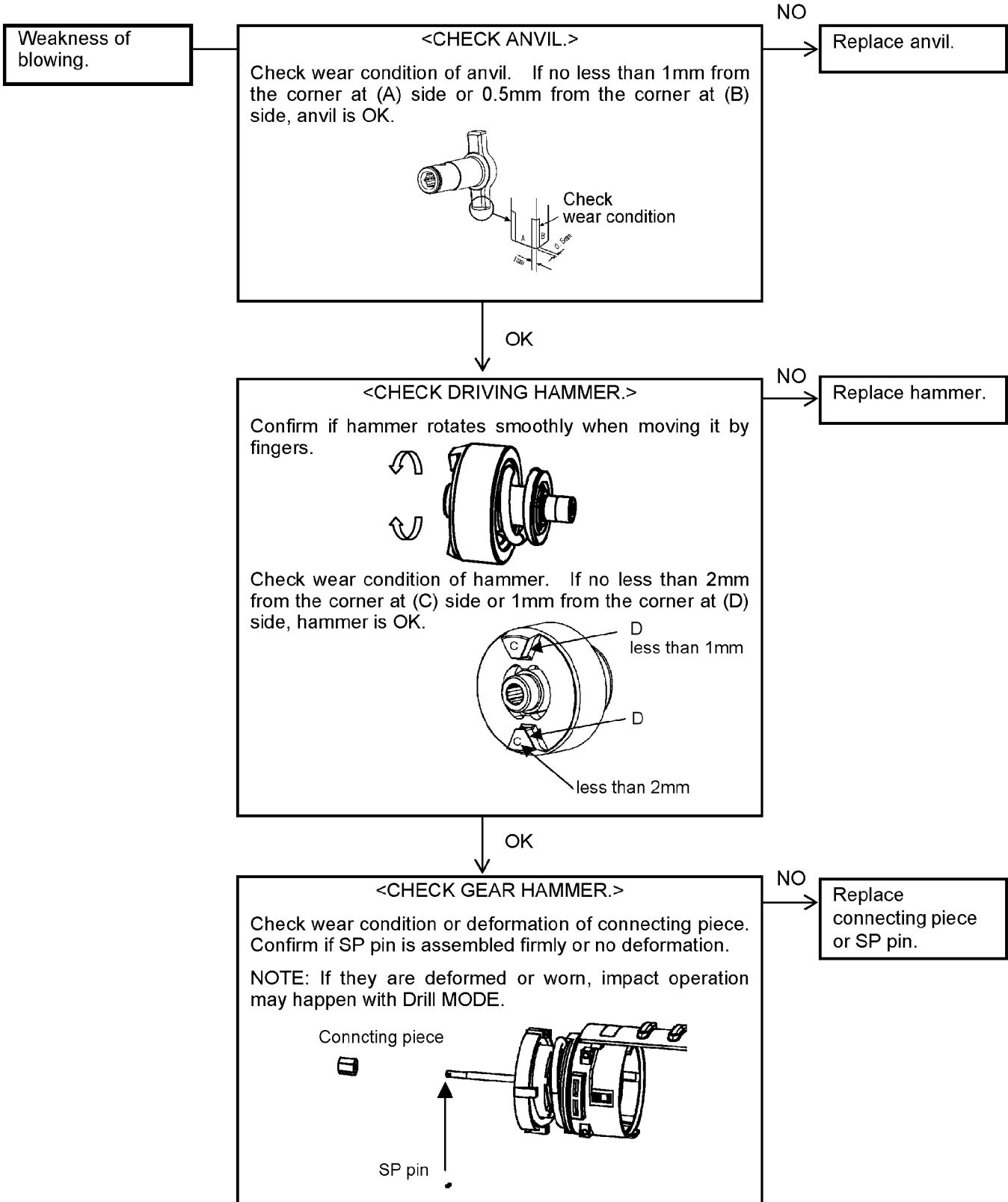

4 Disassembly and Assembly Instructions

4.1. Disassembly Instructions

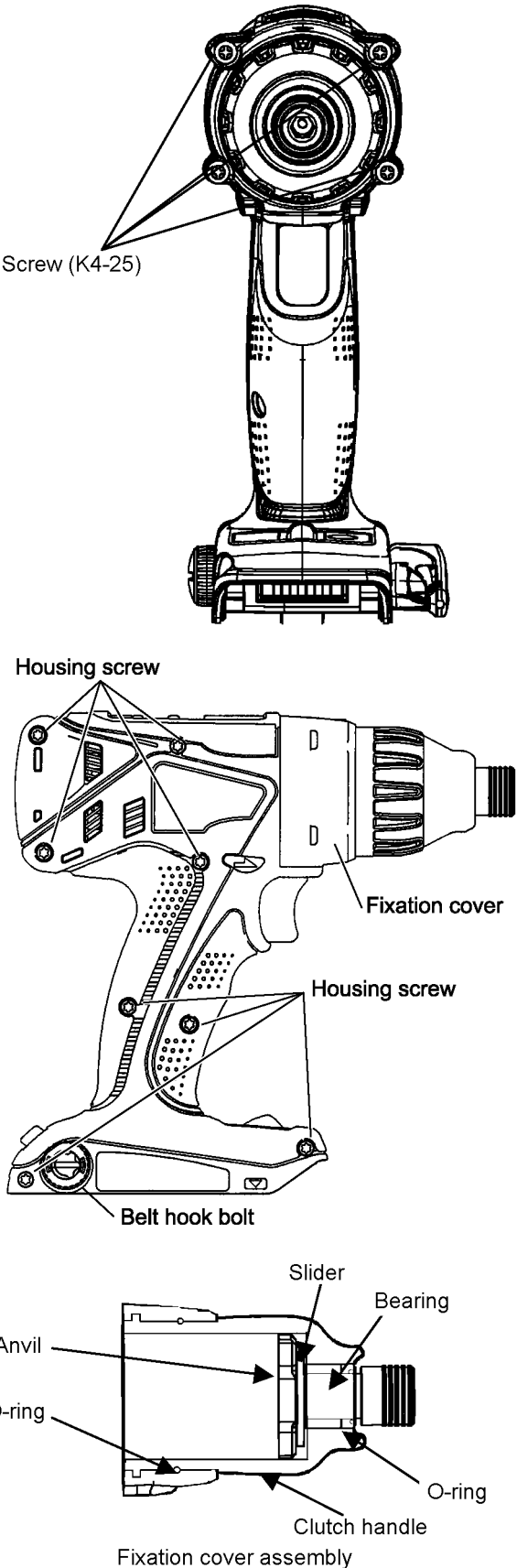
Ref. No. 1A	Procedure 1A	Removal of the Housings.
		<ol style="list-style-type: none">1. Loosen the belt hook bolt turning it counterclockwise, using a coin or a flat blade screwdriver.2. Take out the belt hook.3. Remove four screws where tightening fixing cover.4. Remove eight housing screws.5. Pull off the fixing cover assembly.6. Once removing the clutch handle, the out-put shaft may come out.7. Remove torque click spring and click spring.8. Then open the housing A and B.

Ref. No. 1B	Procedure 1A → 1B	Removal of Motor assembly and Gear hammer block.
		<ol style="list-style-type: none"> 1. Unscrew to disconnect the lead wires between switch and motor. 2. Take out the motor assembly with the gear box block from the housing. 3. Separate the motor assembly from the gear box block. 4. Take out the ring gear from the revolving stand.

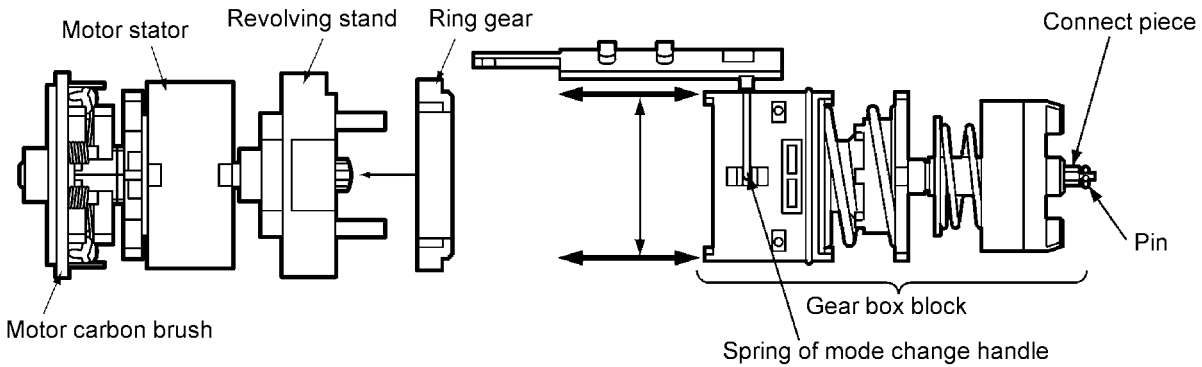

Ref. No. 1C

Procedure 1A → 1B → 1C

Removal of Gear box assembly.

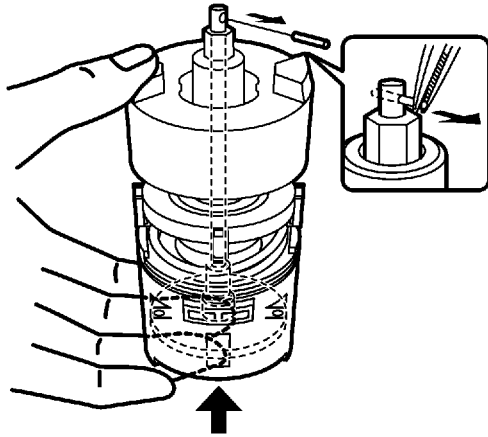

1. Hold the driving carrier as illustrated.
2. Compress the assembly and take out the pin.
3. Take out the driving shaft assembly and the gear case assembly from the shaft of the driving carrier.

NOTE:

Make sure not to lose the pin and the connect piece.

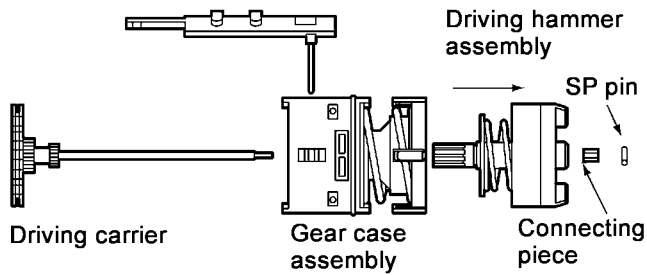

Ref. No. 1D

Procedure 1A → 1B → 1C → 1D

Removal of Gear case assembly.

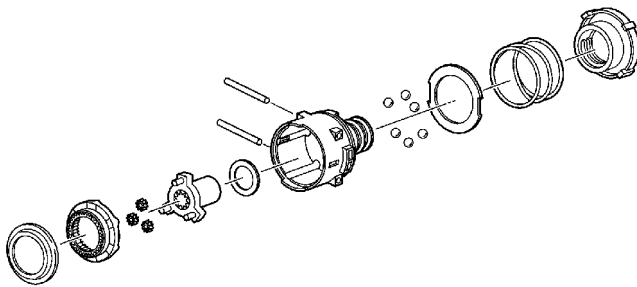

1. Take out the mode change handle.
2. Pull out 2 pins (ϕ 2.5x33.6).
3. After removing pins, the internal parts of the gear case assembly can be removed one after another.

Thrust plate → clutch gear → planet gear (3pcs) → carrier → thrust plate

4. Remove the adjusting screw, clutch spring and clutch plate.
5. After removing the clutch plate, 6 pieces of steel balls come off.

4.2. Reassembly instructions

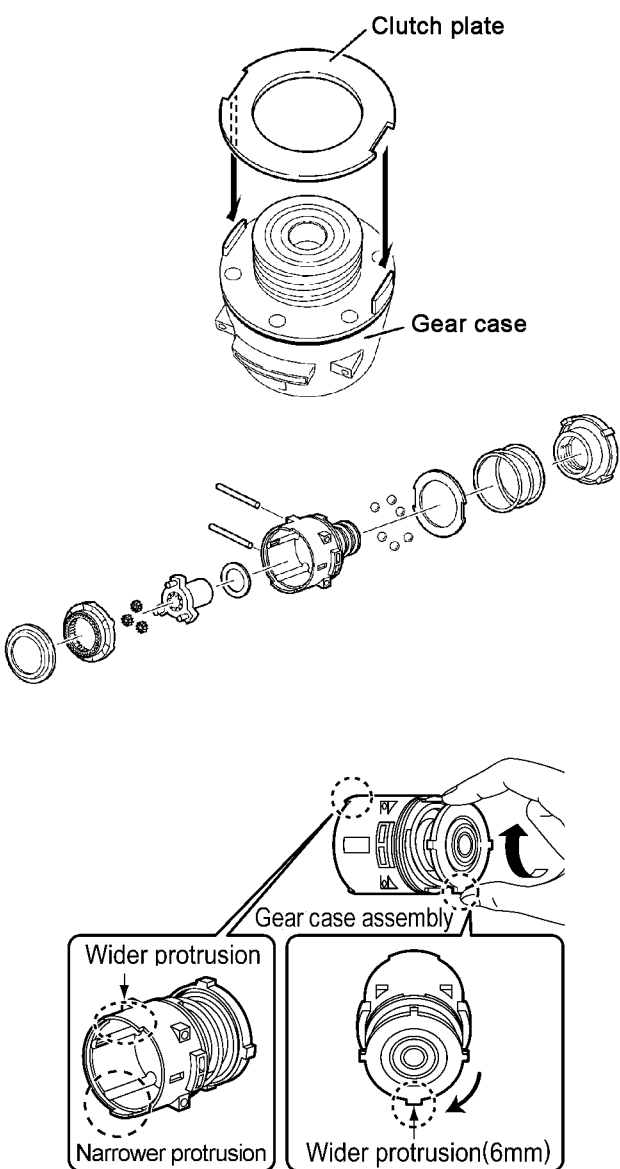
Ref. No. 2A	Procedure 2A	Assembly of Gear case block.
	 <p>Clutch plate</p> <p>Gear case</p> <p>Gear case assembly</p> <p>Wider protrusion</p> <p>Narrower protrusion</p> <p>Wider protrusion(6mm)</p> <p>Mode change handle</p>	<ol style="list-style-type: none">1. Assemble thrust plate, clutch gear, planet gear (3pcs), carrier, thrust plate and insert pins (2pcs).2. Reinstall one piece of steel ball into each of 6 holes.3. Assemble clutch plate and clutch spring.4. Align the widest protrusion of adjusting screw with the narrower protrusion of gear case.5. Turn the adjusting screw into the gear case assembly one rotation for clockwise direction.6. Set the mode change handle on the wider protrusion of gear case.7. Confirm proper position of the mode change handle that both ends of spring must be put into the grooves of the driving carrier.

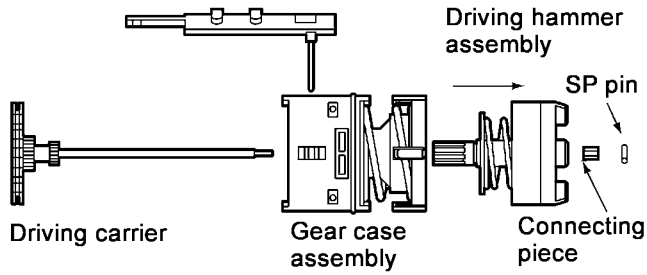

1. Insert the driving carrier into the hole of gear case assembly and the driving hammer assembly.
2. Hold the driving carrier as illustrated and confirm if the connect piece is inside of the driving shaft block.
3. Insert the pin into the shaft of driving carrier holding the bottom of the gear box assembly by hand.
4. Align the wider groove of revolving stand with the wider protrusion of gear case.
5. Assemble the ring gear into the revolving stand and set it on the motor assembly.
6. Place fit the hole of driving carrier and the pins of revolving stand.

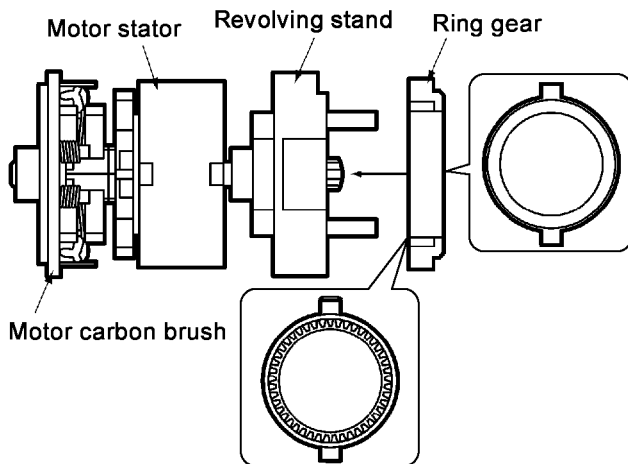
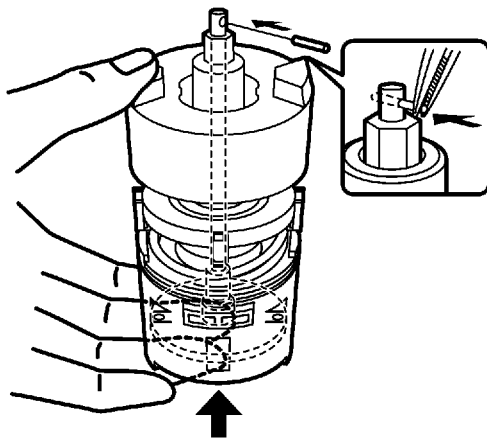
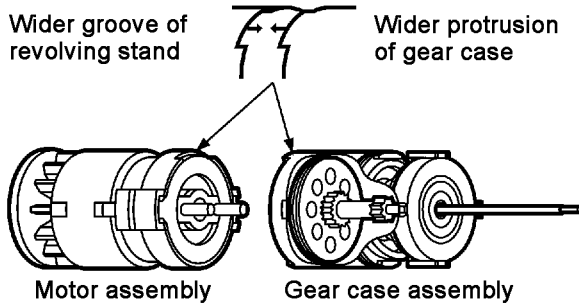

1. Insert the motor and gear & hammer assembly into the housing.
2. Connect the switch assembly with motor lead wires.
3. Set the motor lead wire (black) is on the upper side of switch assembly.
4. Confirm to set the motor lead wire (red) under the black lead wire and confirm if there is no pinching with switch.
5. Place the battery terminal lead wire (black) is over the wire (red) properly.

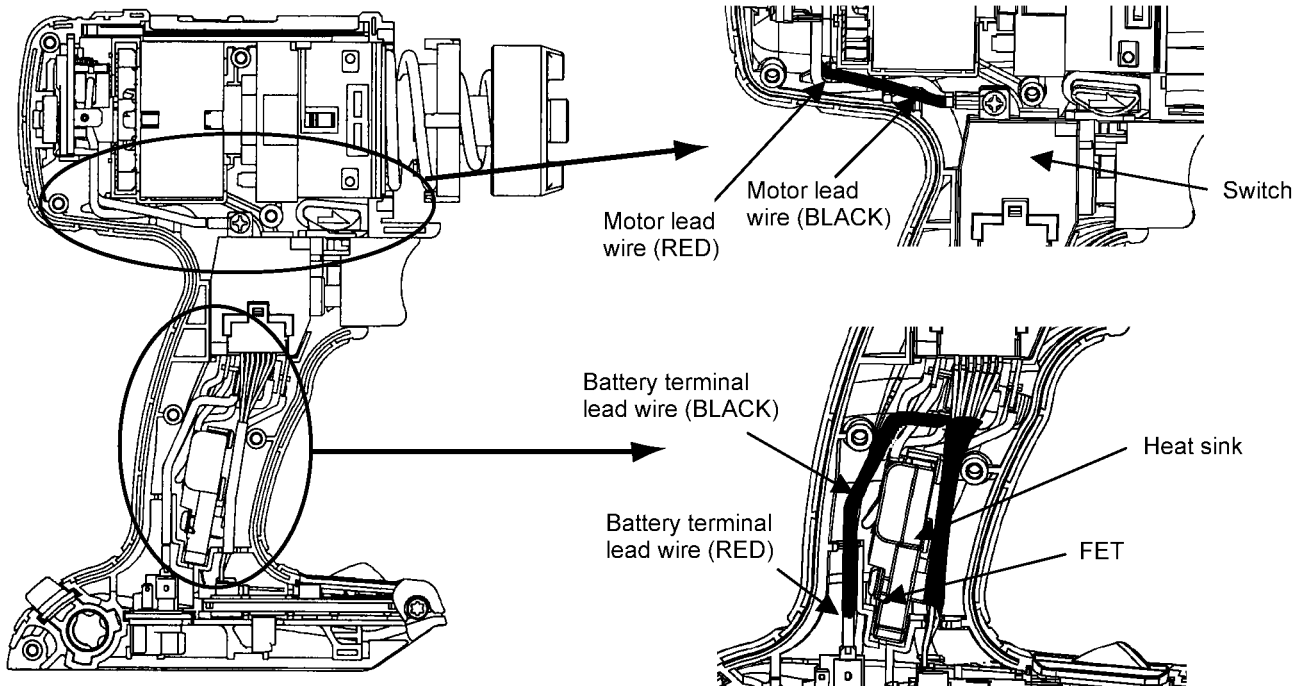

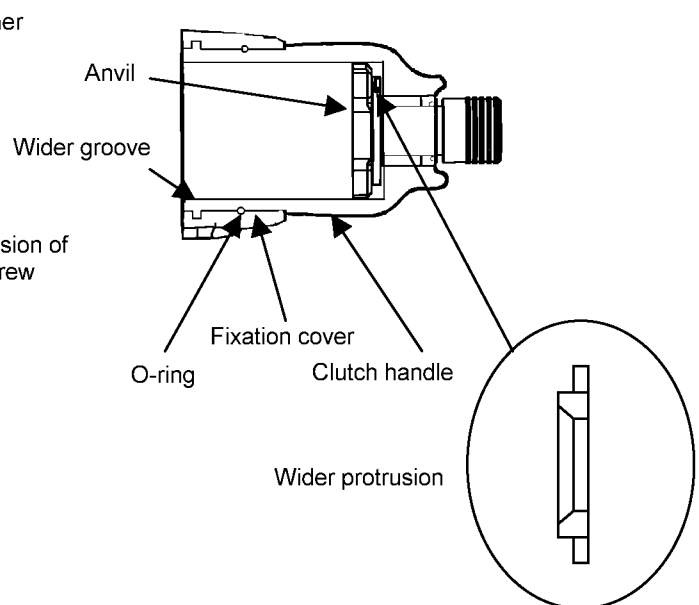
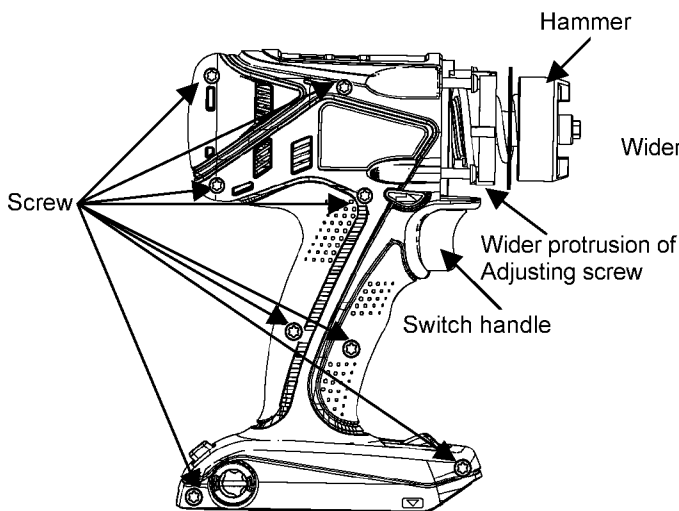
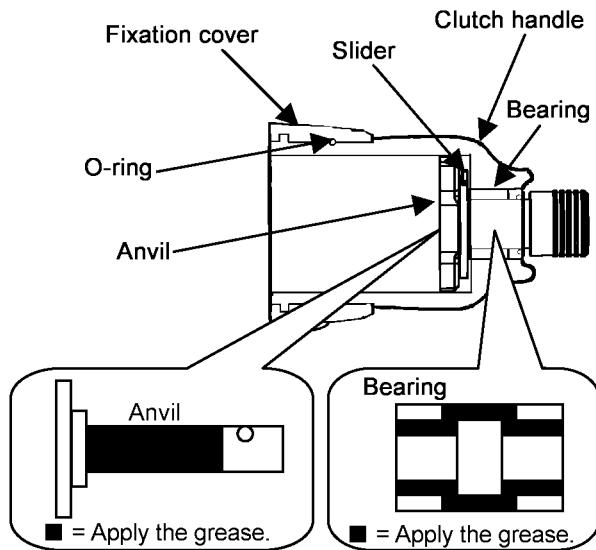
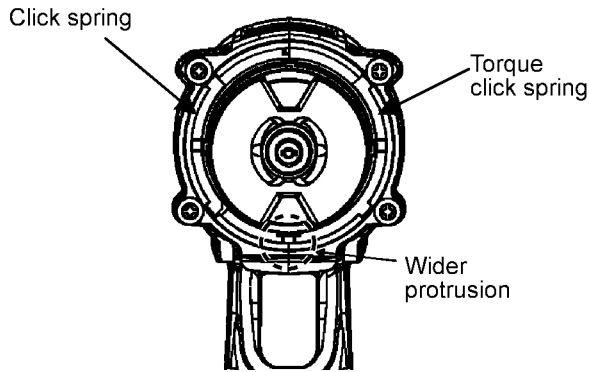

1. Set the hook release lever on the housing.
2. Close the housing A and B.
3. Confirm if the wider protrusion of adjusting screws is placed on bottom (switch side).

NOTE:

- If the adjusting screw does not set correctly, it will make the wrong clutch force.
4. Set the mode change handle to IMPACT drive mode.
 5. Tighten eight housing screws.
 6. Place the torque click spring and click spring properly.
 7. Apply the grease (WEY6507X5537) all around the anvil and the bearing part of clutch handle.
 8. Confirm if O-ring is attached with the clutch handle.
 9. Assemble the slider to the clutch handle. Confirm it has its own direction.
 10. Place the anvil into the clutch handle.
 11. Align the wider protrusion of adjusting screw with the wider groove of the clutch handle.

Assembly of Fixing cover.

1. Place the clutch handle with position 1 on top.
2. Set the fixing cover with  mark on top.
3. Tighten four screws.

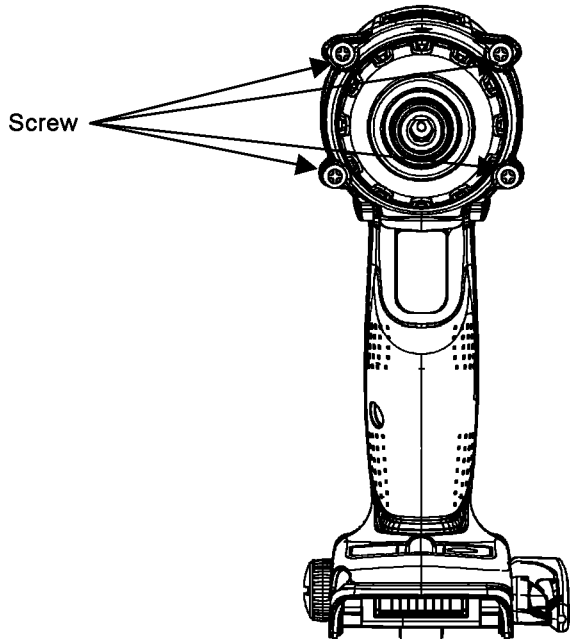
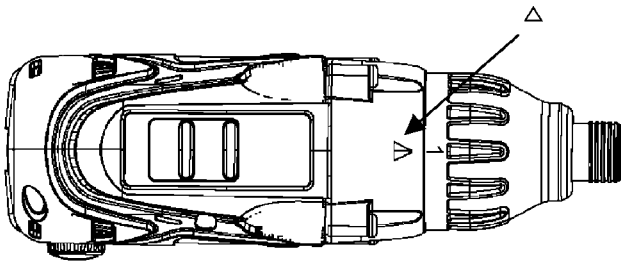

5 Wiring Connection Diagram

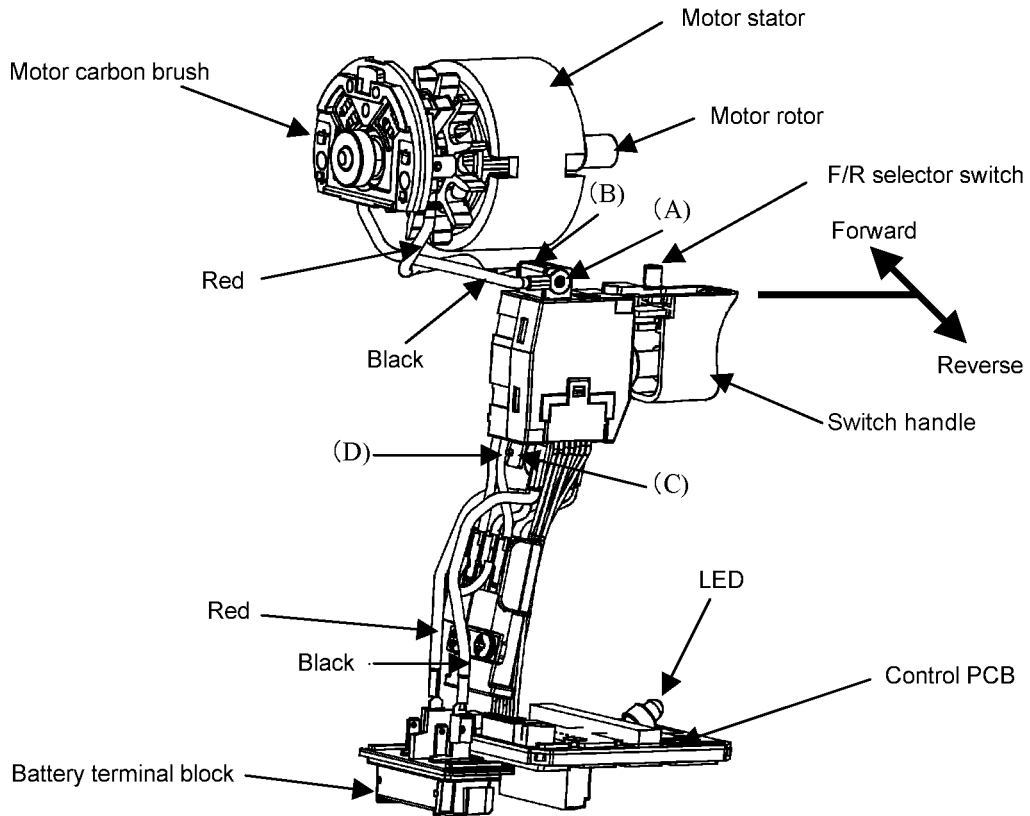

6 Schematic Diagram

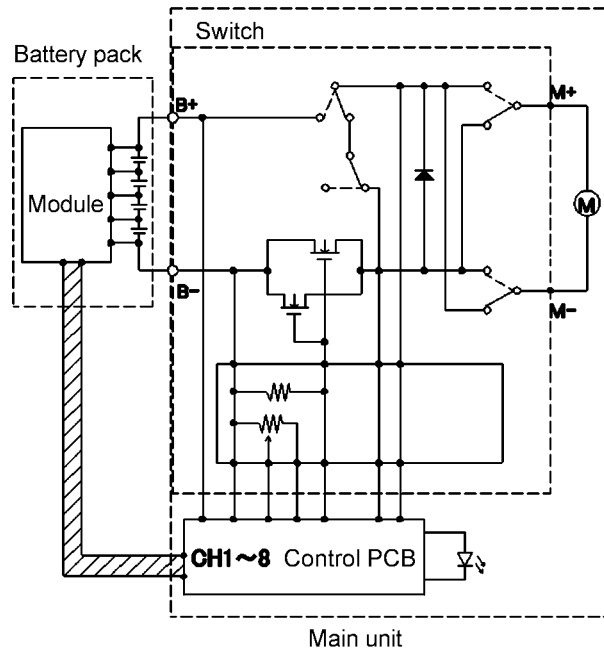

7 Exploded View and Replacement Parts List

Model No. : EY7542 Exploded View

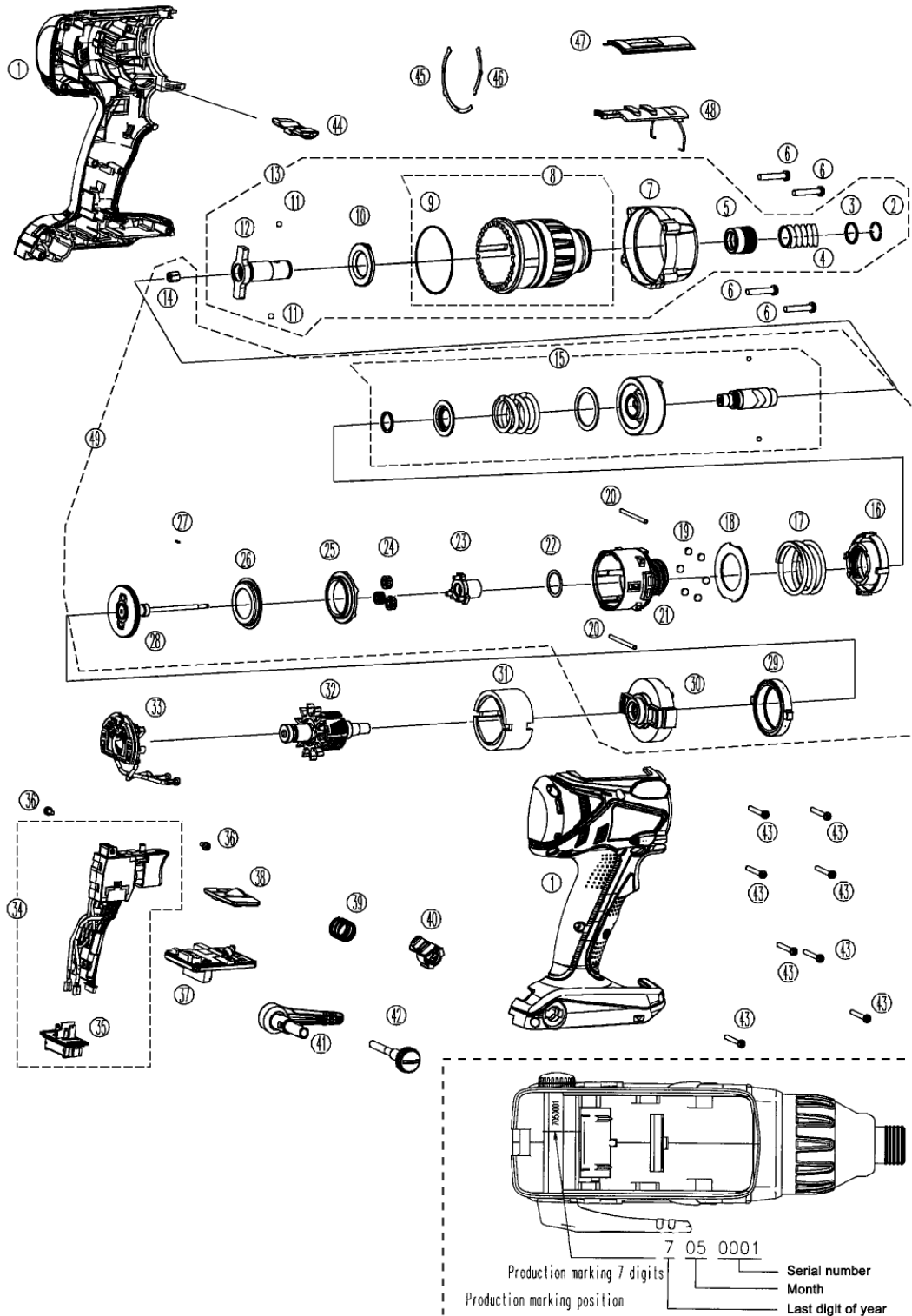

** Battery Pack is available as an optional accessory. See the nearest sales dealer for details.

*** For replacement parts of charger, see the charger service manual.

Charger complete set is available as an optional accessory. See the nearest sales dealer for details.

Model No. : EY7542 Parts List

Safety	Ref. No.	Part No.	Part Name & Description	Q'ty	Remarks
	1	WEY7542K3078	HOUSING AB SET	1	
	2	WEY6507K1167	C-TYPE RING	1	
	3	WEY6507L0857	THRUST PLATE	1	
	4	WEY6507L0197	BIT HOLDER SPRING	1	
	5	WEY6507K3717	BIT HOLDER	1	
	6	WEY6504S9067	TIGHT SCREW	4	(4*25)
	7	WEY6507S0647	FIXING COVER	1	
	8	WEY7542K3747	CLUTCH HANDLE	1	
	9	WEY7542L0968	O-RING	1	
	10	WEY6505L0867	SLIDER	1	
	11	WEY6507L6977	STEEL BALL	2	(φ3.5)
	12	WEY7542L1128	ANVIL	1	
	13	WEY7542K1128	FIXATION COVER ASSEMBLY	1	
	14	WEY6631L0887	CONNECT PIECE	1	
	15	WEY6507L1417	DRIVING SHAFT ASSEMBLY	1	
	16	WEY6507L0637	ADJUSTING SCREW	1	
	17	WEY6507L0167	CLUTCH SCREW	1	
	18	WEY6505L0577	CLUTCH PLATE	1	
	19	WEY6631L6977	STEEL BALL	6	(φ5), (6PCS/PK)
	20	WEY6481L0356	THRUST PIN SET	2	(φ2.5*33.6), (2PCS/PK)
	21	WEY6631L1067	GEAR CASE	1	
	22	WEY6505L0927	THRUST PLATE	1	
	23	WEY6631L1397	CARRIER	1	
	24	WEY6505L1346	PLANET GEAR	3	(3PCS/PK)
	25	WEY6631L1357	CLUTCH GEAR	1	
	26	WEY6631L0907	THRUST PLATE	1	
	27	WEY6505L0917	SP PIN	1	
	28	WEY6507L1367	CARRIER	1	
	29	WEY6507L1457	RING GEAR	1	
	30	WEY7542L0027	MOTOR MOUNTING PLATE	1	
	31	WEY7440L1187	STATOR	1	
	32	WEY7542L1467	MOTOR ROTOR ASSEMBLY	1	
	33	WEY7542L2307	MOTOR BRUSH ASSEMBLY	1	
	34	WEY7542K2007	SWITCH ASSEMBLY	1	
	35	WEY7540L2157	BATTERY TERMINAL BLOCK	1	
	36	WEY6230L6026	SCREW	2	(K3-6)
	37	WEY7542L2117	CONTROL PCB	1	
	38	WEY7440K3958	OPERATION PANEL	1	
	39	WEY7540L0167	SPRING FOR RELEASE LEVER	1	
	40	WEY7540H0407	HOOK RELEASE LEVER	1	
	41	WEY7542K3187	BELT HOOK SET	1	
	42	WEY7205K0257	BELT HOOK BOLT	1	
	43	WEY6230K9216	TORX TAPPING SCREW	9	(K3-20)

Model No. : EY7542 Parts List

Safety	Ref. No.	Part No.	Part Name & Description	Q'ty	Remarks
	44	WEY7542H3247	F/R SELECTOR HANDLE	1	
	45	WEY6631L0977	CLICK SPRING	1	
	46	WEY6505L0187	CLICK SPRING	1	
	47	WEY7542S3238	SELECT SWITCH COVER	1	
	48	WEY7542K3257	I/D CHANGE HANDLE	1	
	49	WEY7542L1458	GEAR BOX BLOCK	1	
	-	WEY7440K7018	TOOL CASE	1	[SH]
	-	WEY7542K8108	OPERATING INSTRUCTIONS	1	[SH]

Free Manuals Download Website

<http://myh66.com>

<http://usermanuals.us>

<http://www.somanuals.com>

<http://www.4manuals.cc>

<http://www.manual-lib.com>

<http://www.404manual.com>

<http://www.luxmanual.com>

<http://aubethermostatmanual.com>

Golf course search by state

<http://golfingnear.com>

Email search by domain

<http://emailbydomain.com>

Auto manuals search

<http://auto.somanuals.com>

TV manuals search

<http://tv.somanuals.com>