

Equipment Manual

**Monarch®
9416® XL®
Thermal
Transfer
Printer**

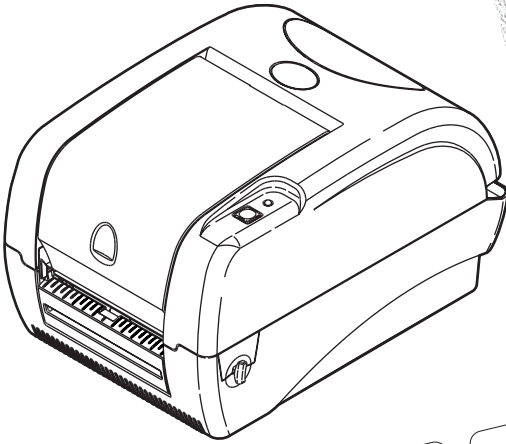

Each product and program carries a respective written warranty, the only warranty on which the customer can rely. Paxar reserves the right to make changes in the product, the programs, and their availability at any time and without notice. Although Paxar has made every effort to provide complete and accurate information in this manual, Paxar shall not be liable for any omissions or inaccuracies. Any update will be incorporated in a later edition of this manual.

©2004 Paxar Americas, Inc. All rights reserved. No part of this publication may be reproduced, transmitted, stored in a retrieval system, or translated into any language in any form by any means, without the prior written permission of Paxar Americas, Inc.

WARNING

This equipment has been tested and found to comply with the limits for a Class A digital device, pursuant to Part 15 of the FCC Rules. These limits are designed to provide reasonable protection against harmful interference when the equipment is operated in a commercial environment. This equipment generates, uses, and can radiate radio frequency energy and, if not installed and used in accordance with the instruction manual, may cause harmful interference to radio communications. Operation of this equipment in a residential area is likely to cause harmful interference in which case the user will be required to correct the interference at his own expense.

CANADIAN D.O.C. WARNING

This digital apparatus does not exceed the Class A limits for radio noise emissions from digital apparatus set out in the Radio Interference Regulations of the Canadian Department of Communications.

Le présent appareil numérique n'émet pas de bruits radioélectriques dépassant les limites applicables aux appareils numériques de la classe A prescrites dans le Règlement sur le brouillage radioélectrique édicte par le ministère des Communications du Canada.

Trademarks

MONARCH®, 9416®, and XL® are registered trademarks of Paxar Americas, Inc. Paxar® is a trademark of Paxar Corporation.

Avery Dennison® is a trademark of Avery Dennison Corporation.

Microsoft and MS-DOS are registered trademarks of Microsoft Corporation.

Windows is a registered trademark of Microsoft in the U.S. and other countries.

Centronics is a registered trademark of Centronics Data Computer Corporation.

Avery Dennison Printer Systems Division
170 Monarch Lane
Miamisburg, Ohio 45342



TABLE OF CONTENTS

Getting Started	1-1
Introduction.....	1-1
Audience	1-1
Ordering the Packet Reference Manual	1-1
Disclaimer.....	1-1
Unpacking the Printer.....	1-2
Connecting the Power Supply.....	1-2
Connecting the Communication Cable	1-4
USB Port	1-5
Reading the Indicator Light	1-6
Loading A Ribbon	2-1
Replacing a Ribbon.....	2-6
Loading Supplies.....	3-1
Loading Supply for Non-Peel Mode.....	3-1
Loading Labels for Peel Mode	3-7
Loading Fan-Fold Supplies	3-13
Calibrating the Supply	3-15
Adjusting the Black Mark/Die Cut Sensor	3-16
Printing	4-1
Care and Maintenance.....	5-1
Clearing Supply Jams.....	5-1
Cleaning the Printhead.....	5-2
Cleaning the Platen Roller and Printer	5-4

Troubleshooting..... 6-1
 Printing Problems and Solutions 6-1
 Printing Test Labels 6-4
 Calibrating the Supply 6-5

Specifications and Accessories..... A-1
 Printer Specifications A-1
 Supply Specifications A-2
 Ribbon Specifications A-2
 Printer Accessories A-2

GETTING STARTED

1

The Monarch® 9416® XL® Thermal Transfer printer is a desktop thermal transfer and thermal direct printer. It can print labels, tags or receipts (with or without bar codes) in peel mode (one label at a time) or non-peel mode (labels in strips).

Introduction

This chapter includes information about

- ◆ unpacking the printer
- ◆ connecting the power supply
- ◆ connecting the communication cable
- ◆ reading the indicator light.

Audience

This *Equipment Manual* is for the person who prints and applies labels.

Ordering the Packet Reference Manual

The printer uses Monarch® Printer Control Language II (MPCL II) to create labels for printing. The *Packet Reference Manual*, available on our Web site (www.monarch.com), describes how to create format and batch packets for printing labels, how to configure the printer, and perform other advanced techniques.

Disclaimer

Information in this document supersedes information in previous versions. Check our Web site for the latest documentation and release information.

Unpacking the Printer

After you unpack the printer, you should have

- ◆ 9416 printer
- ◆ power supply/power cord
- ◆ ribbon reel
- ◆ take-up core (already on the take-up reel)
- ◆ *Quick Reference*
- ◆ CD-ROM that contains software and manuals (included with applicable models).

If any items are missing, contact Monarch for replacement parts.

Keep all packaging material in case you need to move or return the printer.

Connecting the Power Supply

CAUTION

Do Not touch the electrical connectors while setting up the printer. Electrostatic discharge can damage or destroy the printhead or electronic components.

To connect the power supply:

1. Place the printer in a location that allows easy access to the front of the printer.
-

The printer should never be operated while resting on its side or upside down.

2. Place the power supply in a suitable location, preferably on the floor, near an electrical outlet.

1-2 Getting Started

3. Turn off the printer. Press the switch on the back of the printer to the OFF position (O).
4. Plug the three-hole end of the AC adapter cable into the three-pronged outlet in the power supply.
5. Plug the round end of the power supply cable (labeled “printer”) into the socket at the back of the printer.

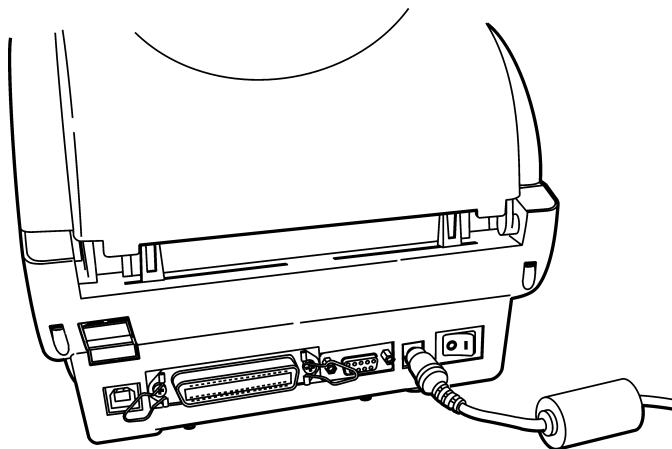

6. Plug the three-pronged end of the AC adapter cable into a grounded electrical outlet.

WARNING

The printer and power supply should never be operated in a location where either one can get wet. Personal injury could result.

Connecting the Communication Cable

Before the printer can accept print jobs from the host, you must

- ◆ connect the communication cable to the printer and the host
- ◆ set the communication values on the printer to match those at the host (only required if you are using the serial port).

For parallel communication:

1. Turn off the printer before connecting the cable.
2. Connect a parallel printer cable from the host to the parallel port at the back of the printer.

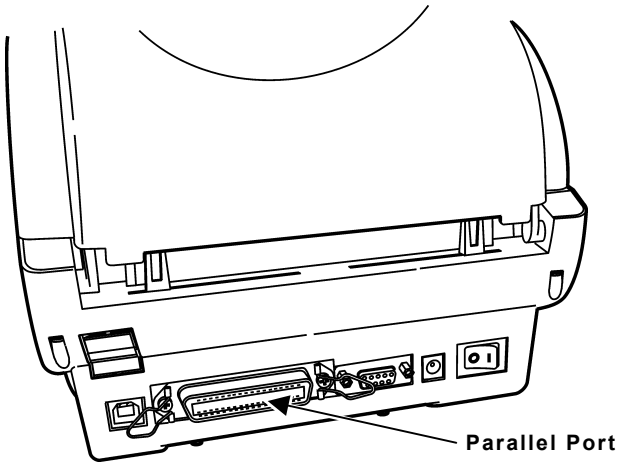

3. Secure the cable with the spring clips.

For serial communication:

1. Turn off the printer before connecting the cable.
2. Connect a serial printer cable from the host to the serial port at the back of the printer.

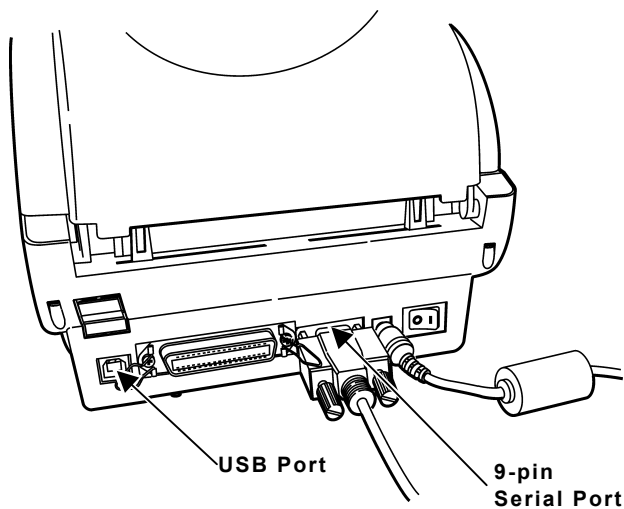

3. Secure the cable with the connecting screws.
The factory defaults are 9600 Baud, no parity, 8-bit data frame, 1 stop bit, and DTR flow control (96, N, 8, 1, DTR).
To set communication values, refer to the *Packet Reference Manual*.

USB Port

The printer has a USB (Universal Serial Bus) Version 1.1 communication port. Drivers are available on our Web site for a variety of operating systems.

Reading the Indicator Light

The indicator light monitors the printer's status.

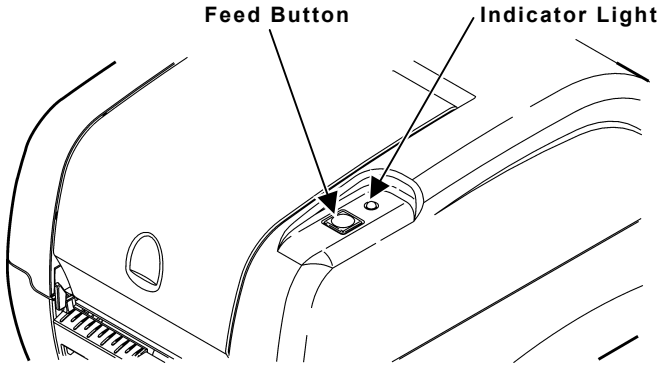

Indicator Light	Description
GREEN	Printer is on and ready to use.
FLASHING GREEN	Printer is paused. Press the FEED button to resume printing.
FLASHING RED	Printer error condition. See Chapter 6, "Troubleshooting" for error conditions and solutions.
ORANGE	The system is detecting the supply and ribbon status.
No light	Printer is off. Make sure the power supply is connected properly. See "Connecting the Power Supply" earlier in this chapter.

LOADING A RIBBON

2

This chapter describes how to load a ribbon.

Use a ribbon when printing on thermal transfer supplies.

There are two types of supplies:

Thermal Direct Supplies do not use a ribbon for printing.

Thermal Transfer Supplies require a ribbon for printing.

If you are using thermal direct supplies, do not load a ribbon. See Chapter 3, “Loading Supplies” for more information.

The printer automatically detects if a ribbon is installed when you turn on the printer and switches to thermal transfer printing mode.

Make sure the ribbon window and the supply door are closed when you turn on the printer.

To load the ribbon:

1. Push down on the ribbon window to unlock it and raise the window.
2. The ribbon take-up core should already be on the take-up reel. Attach the take-up core to the front hub, as shown.

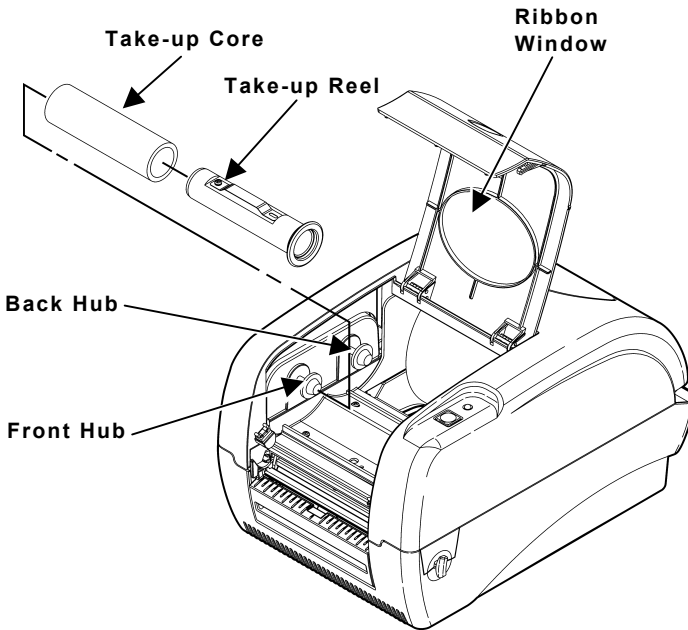

2-2 Loading A Ribbon

3. Open a package of new ribbon, taking care not to wrinkle or crush the ribbon.

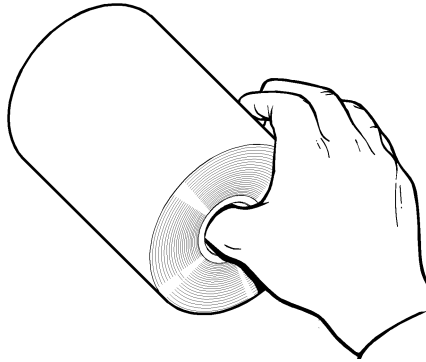

4. Slide the ribbon onto the ribbon reel as far as it will go.

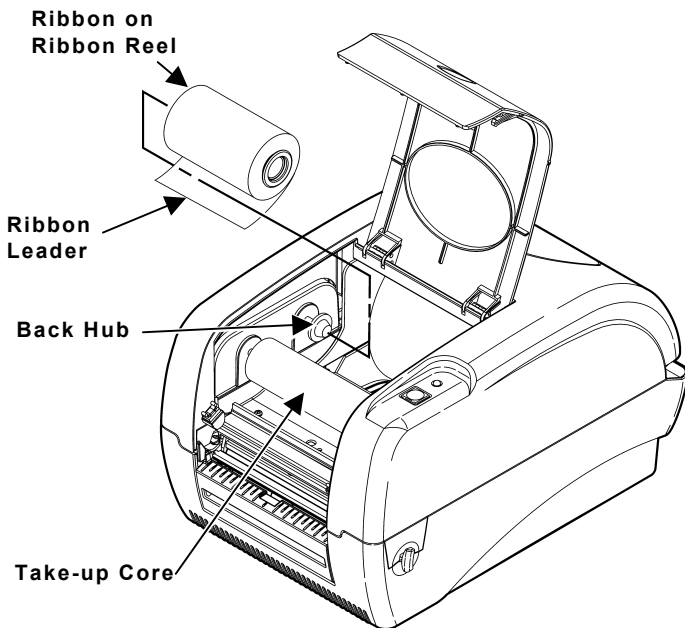

- 5.** Attach the ribbon reel to the back hub.
- 6.** Peel and carefully unwind a few inches of ribbon from the bottom of the roll.
- 7.** Press the release levers towards the front of the printer to release the supply door.
- 8.** Lift open the supply door. The supply door support at the right-hand rear of the printer holds the supply door open.
- 9.** Feed the end of the ribbon under the printhead and around the take-up core.
- 10.** Stick the leading edge of the ribbon onto the take-up core.
- 11.** Rotate the take-up core until the ribbon leader is firmly wrapped around the take-up core and the black portion of the ribbon is exposed.

2-4 Loading A Ribbon

- 12.** Close the supply door by lifting the supply door slightly and pulling the bottom of the supply door support forward towards the front of the printer. Close the supply door slowly and make sure it latches securely.

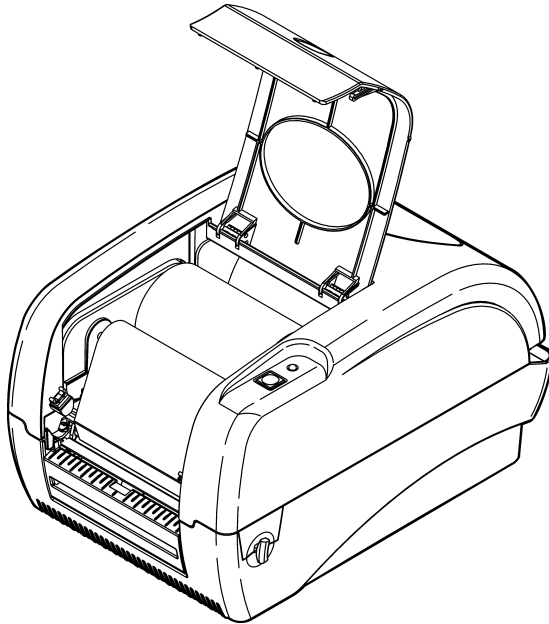

If you do not latch the supply door completely, poor print quality may result.

- 13.** Press the ribbon window down firmly until it locks into place.

Replacing a Ribbon

To replace a ribbon:

1. Push down on the ribbon window to unlock it and raise the window.
2. Remove and discard the used ribbon and take-up core. **Save the ribbon reel located inside the take-up core before discarding.**
3. Remove the ribbon reel (with core) from the back hub and place it on the front hub.

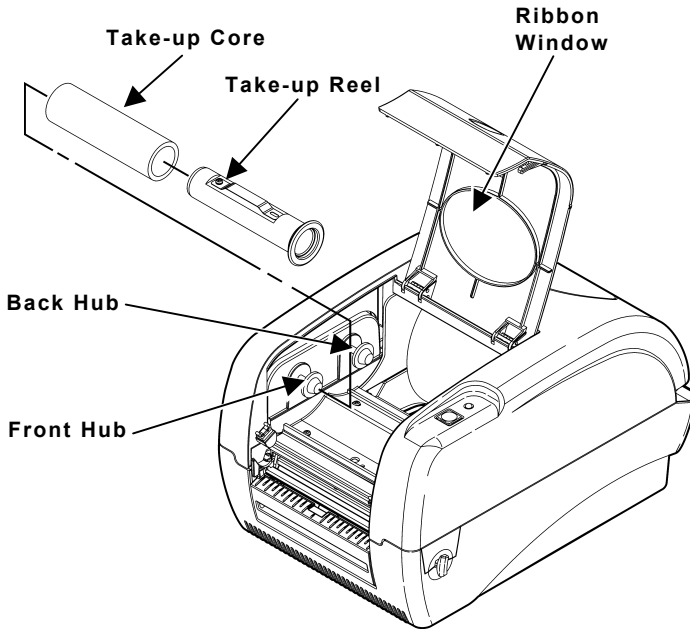

4. Follow the steps from the previous section to finishing loading the ribbon.

2-6 Loading A Ribbon

LOADING SUPPLIES

3

This chapter describes how to

- ◆ load a roll of labels or tags for non-peel mode
- ◆ load a roll of labels for peel mode
- ◆ load fan-fold supplies.

Loading Supply for Non-Peel Mode

This section describes how to load supplies in the printer to print in non-peel (continuous) mode. Make sure the black mark/die cut sensor is set correctly for your supply type. See “Adjusting the Black Mark/Die Cut Sensor,” for more information.

If you run out of supply while printing, do not turn off the printer when reloading the supply. You may lose your data. The printer resumes printing when reloaded.

- 1.** Remove and discard the tape from a new roll of supply. Unwrap and discard supply with any glue residue.

2. Press the release levers (located on both sides of the printer) towards the front of the printer to release the supply door.

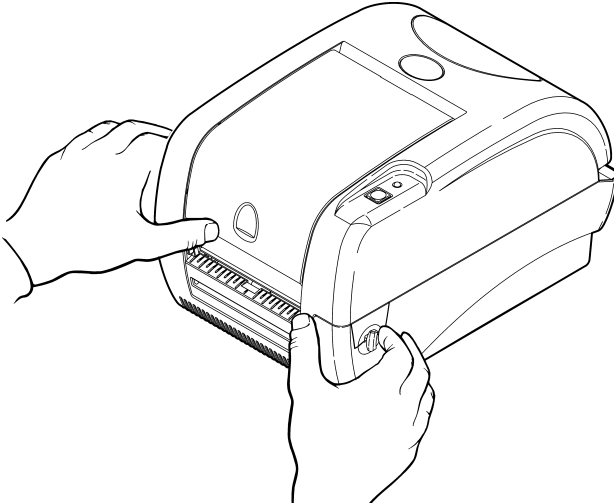

3. Lift open the supply door. The supply door support at the right-hand rear of the printer holds the supply door open.

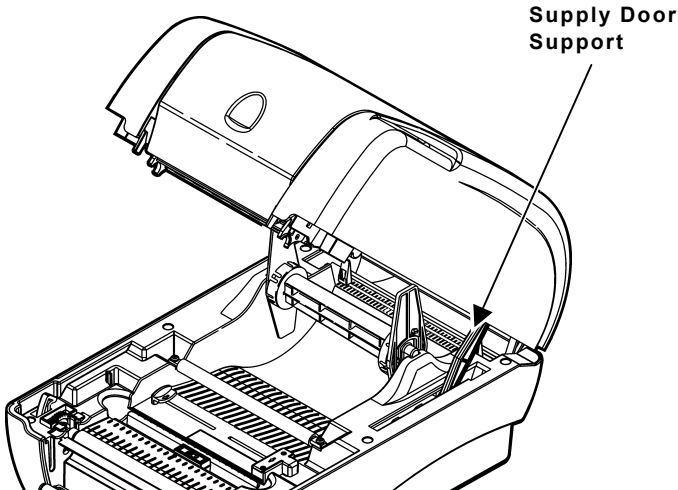

3-2 Loading Supplies

4. Remove the supply holder guide from one end of the supply holder. (The supply holder is normally attached with a line to the inside of the printer, not free-standing as shown below. Do not cut the line.)

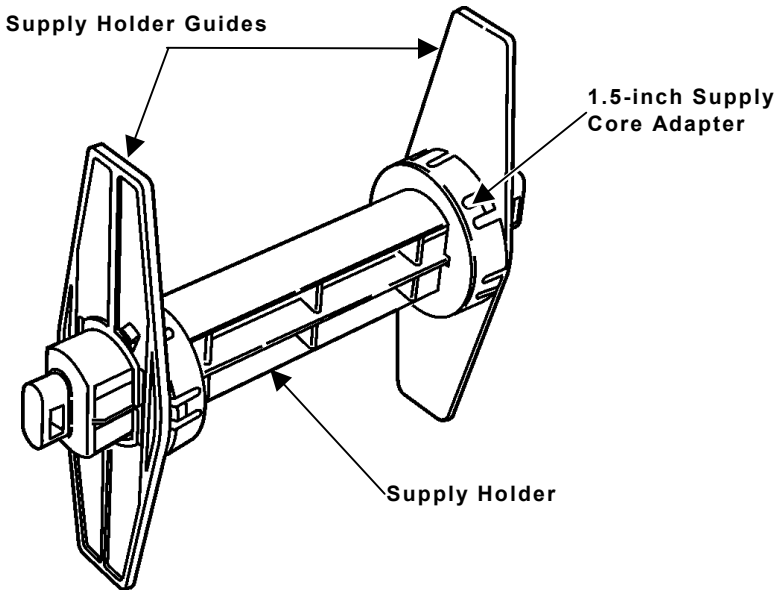

5. Slide a roll of supply onto the supply holder.

If the core diameter on your roll of supply is 1 inch in diameter, remove the 1.5-inch supply core adapters from the supply guide holders.

6. Slide the supply holder guide back onto the end of the supply holder. If you are using the supply core adapters for 1.5-inch core supply, make sure to push the supply core adapters into the ends of the supply.

7. Insert the ends of the supply holder into the slots in the supply roll mount.

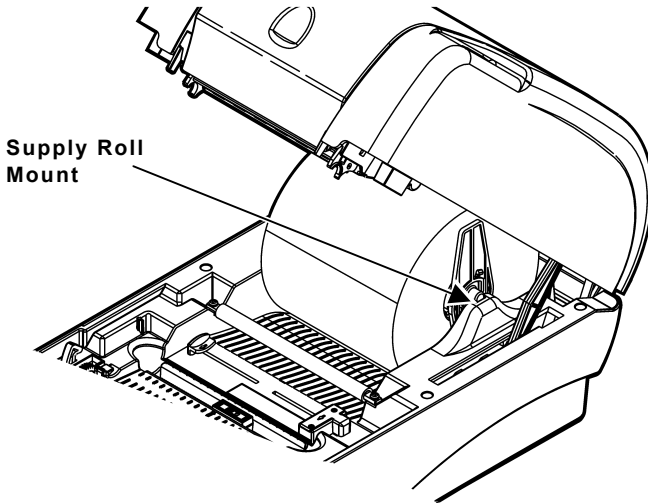

IMPORTANT INFORMATION

Make sure the plastic line attaching the supply holder to the printer is tucked down out of the way of the supply holder and supply holder guides. Otherwise, the plastic line may wrap around the supply holder or get caught on the supply holder guides.

8. Slide the supply guides to their widest position.

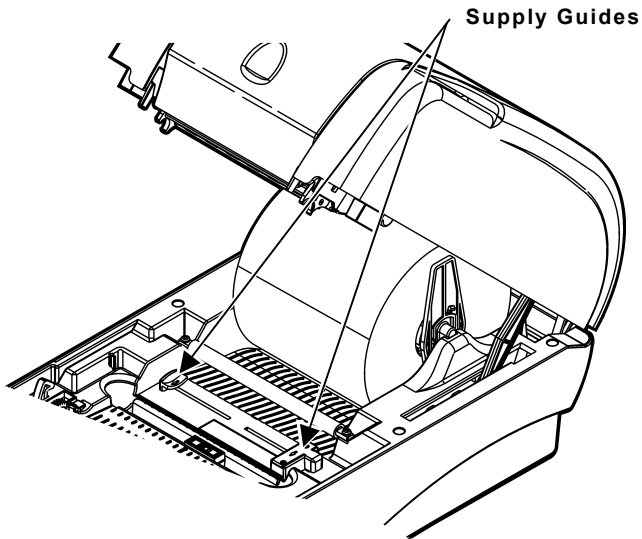

9. Feed the supply, printing side up, under the white roller, under the supply guides, and over the platen roller.

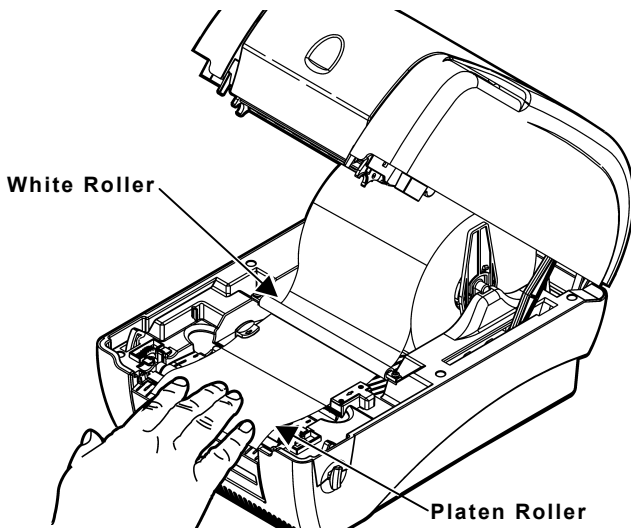

Loading Supplies 3-5

10. Press the supply under the supply guides.
11. Slide the supply guides so that they barely touch the edges of the backing paper.
12. Close the supply door by lifting the supply door slightly and pulling the bottom of the supply door support forward towards the front of the printer. Close the supply door slowly and make sure it latches securely.

If you do not latch the supply door completely, poor print quality may result.

13. Press the **FEED** button. The indicator light should be GREEN.



14. Calibrate the supply if necessary. See "Calibrating the Supply," for more information.

Loading Labels for Peel Mode

Peel mode separates the label from the backing paper while printing.

NOTE

The minimum label length for peeling is 0.75 inches (19 mm). Hold the leading edge of peeled labels when printing on supply longer than six inches.

1. Remove and discard the tape from a new roll of supply. Unwrap and discard supply with any glue residue.
2. Press the release levers (located on both sides of the printer) towards the front of the printer to release the supply door.
3. Lift open the supply door. The supply door support at the right-hand rear of the printer holds the supply door open.

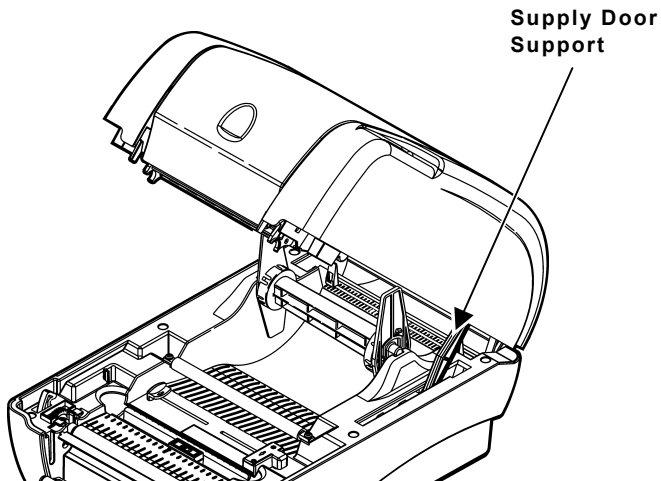

4. Pull out the peel door located on the front of the printer to display the peel roller and the peel bar.

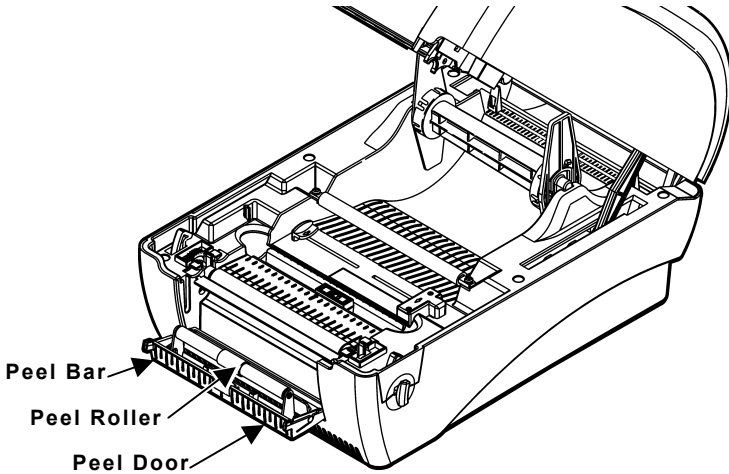

5. Remove the supply holder guide from one end of the supply holder. (The supply holder is normally attached with a line to the inside of the printer, not free-standing as shown below. Do not cut the line.)

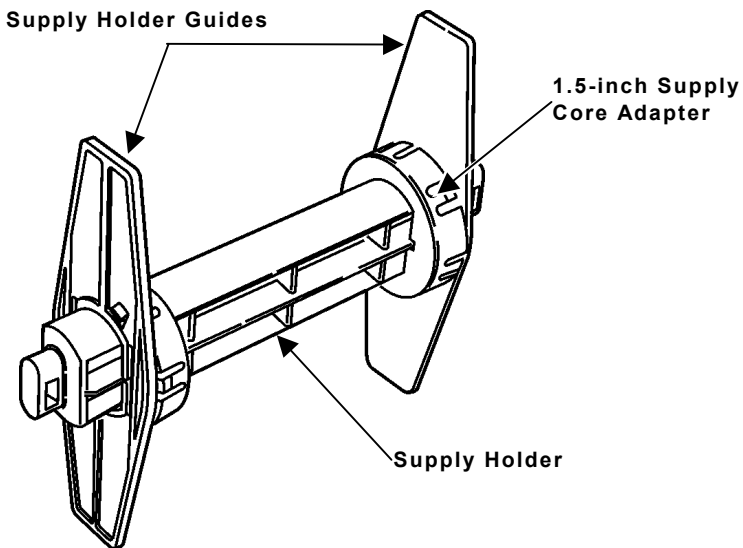

3-8 Loading Supplies

6. Slide a roll of labels onto the supply holder.

If the core diameter on your roll of labels is 1 inch in diameter, remove the 1.5-inch supply core adapters from the supply holder guides.

7. Slide the supply holder guide back onto the end of the supply holder. If you are using the supply core adapters for 1.5-inch core supply, make sure to push the supply core adapters into the ends of the supply.
8. Insert the ends of the supply holder into the slots in the supply roll mount.

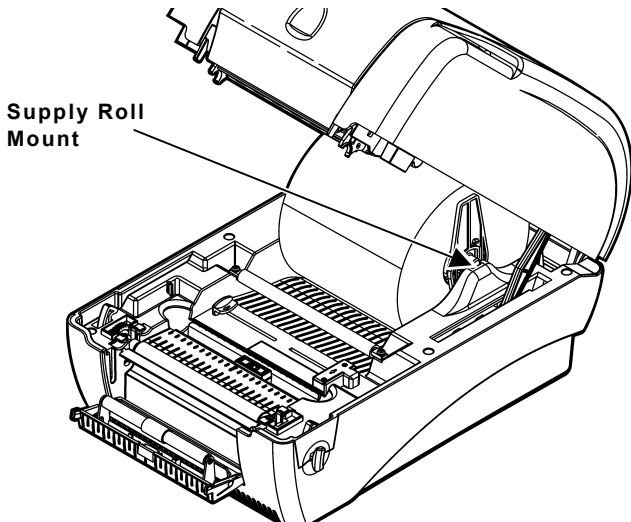

IMPORTANT INFORMATION

Make sure the plastic line attaching the supply holder to the printer is tucked down out of the way of the supply holder and supply holder guides. Otherwise, the plastic line may wrap around the supply holder or get caught on the supply holder guides.

- 9.** Slide the supply guides to their widest position.
- 10.** Remove the first two labels from the backing paper.
- 11.** Feed the labels, printing side up, under the white roller, under the supply guides, and over the platen roller.

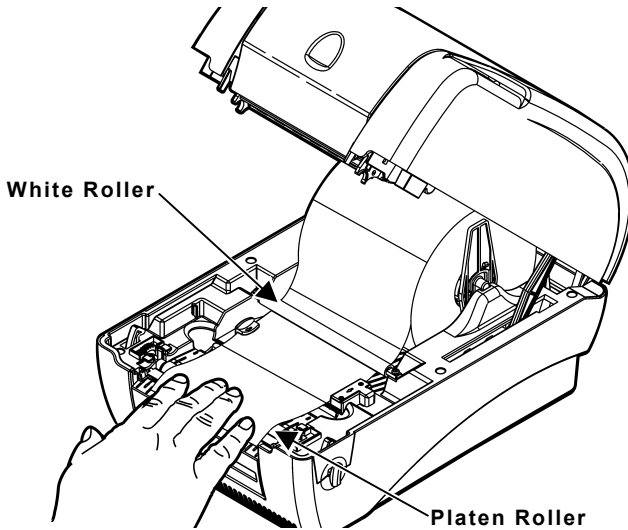

- 12.** Press the labels under the supply guides.
- 13.** Slide the supply guides so that they barely touch the edges of the backing paper.

3-10 Loading Supplies

14. Feed the backing paper under the peel roller and through the peel door opening.

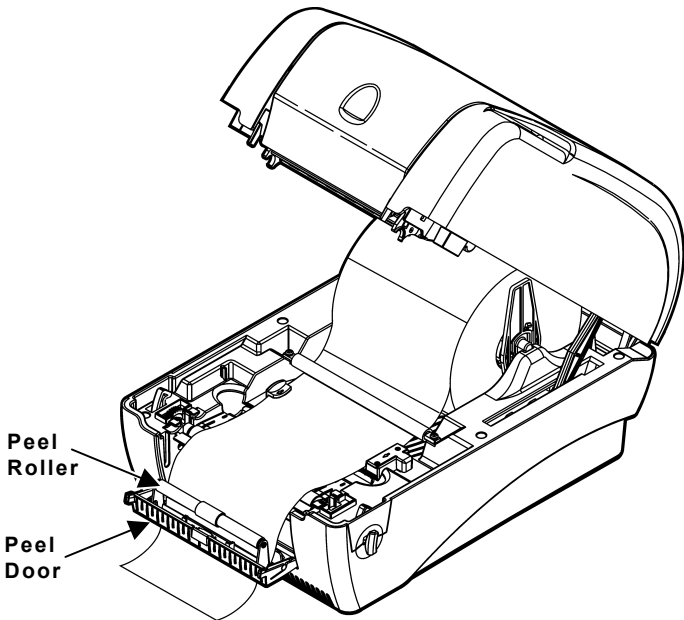

15. Push the peel door closed until it locks. If the peel door is not completely closed, the supply door does not close properly.
16. Close the supply door by lifting the supply door slightly and pulling the bottom of the supply door support forward towards the front of the printer. Close the supply door slowly and make sure it latches securely.

If you do not latch the supply door completely, poor print quality may result.

17. Press the **FEED** button. A label separates from the backing paper. Remove the peeled label and another one prints.

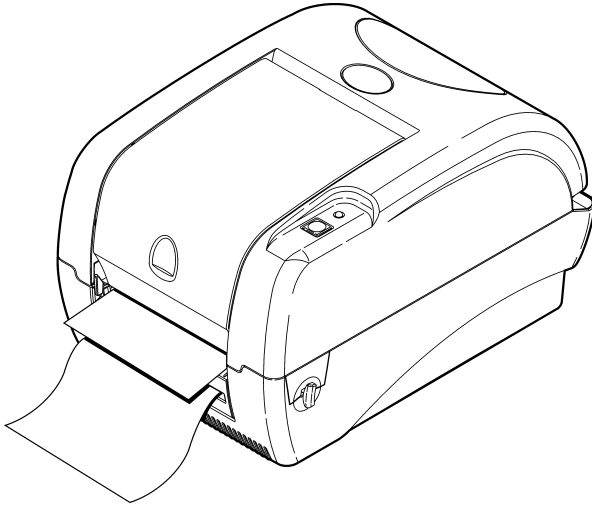

NOTE

Hold the leading edge of peeled labels when printing on supply longer than six inches.

18. Calibrate the supply if necessary. See “Calibrating the Supply,” for more information.

Loading Fan-Fold Supplies

1. Place a stack of fan-fold supplies behind the printer, printing side up.

You may have to move the printer
to allow room for the supply.

2. Push the external supply guides (located on the back of the printer) out to their widest position.

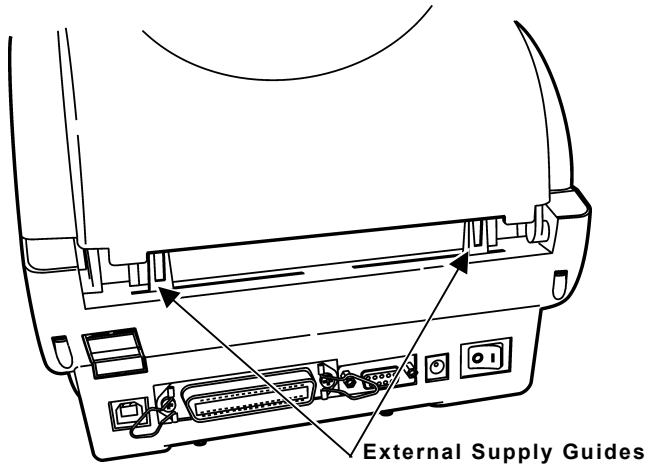

3. Adjust the external supply guides so that they barely touch the edges of the supply.
4. Feed the fan-fold supplies, printing side up, into the external supply slot on the back of the printer and through the external supply guides.
5. Press the release levers (located on each side of the printer) towards the front of the printer to release the supply door.
6. Lift open the supply door. The supply door support at the right-hand rear of the printer holds the supply door open.
7. Leave the supply holder in the printer.

- 8.** Slide the internal supply guides to their widest position.
- 9.** Feed the fan-fold labels through the supply guides, under the supply holder, under the white roller, and over the platen roller.

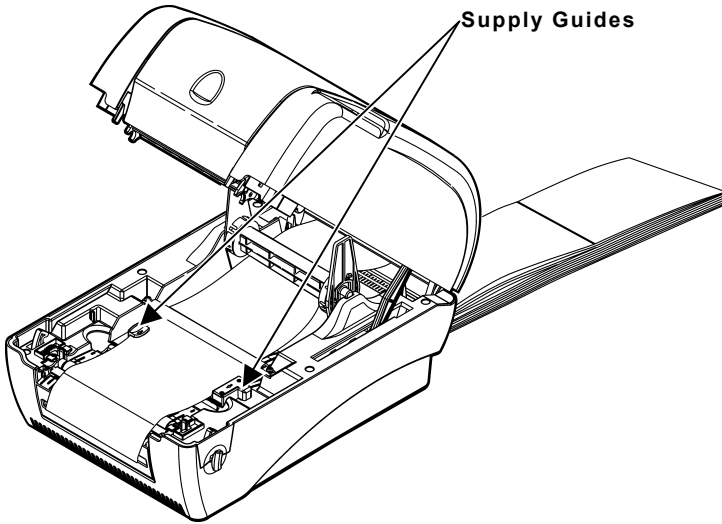

- 10.** Press the fan-fold labels under the supply guides.
- 11.** Slide the internal supply guides so that they barely touch the edges of the supply.
- 12.** Close the supply door by lifting the supply door slightly and pulling the bottom of the supply door support forward towards the front of the printer. Close the supply door slowly and make sure it latches securely.

If you do not latch the supply door completely, poor print quality may result.

3-14 Loading Supplies

13. Press the **FEED** button. The indicator light should be GREEN.

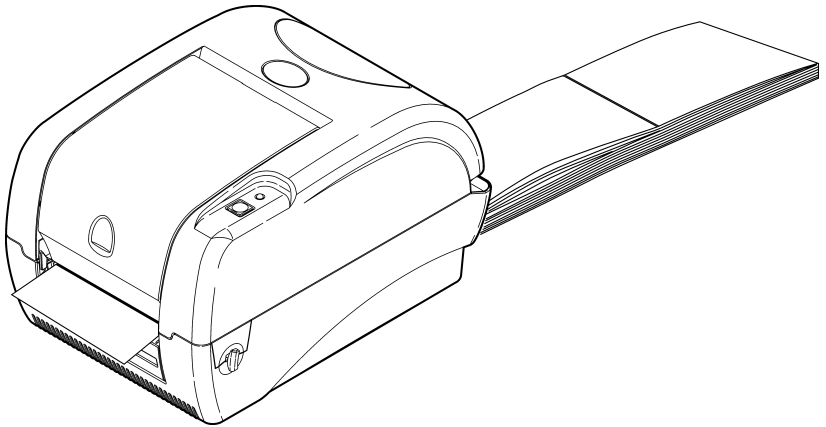

14. Calibrate the supply if necessary. See “Calibrating the Supply,” for more information.

Calibrating the Supply

1. Turn off the printer.
2. Press and hold the **FEED** button while turning on the printer.
3. *To calibrate the supply*, release the **FEED** button after the indicator light starts flashing ORANGE. The printer calibrates the black mark or die cut sensor, measures the label length, and prints the test labels.
To calibrate the ribbon, release the **FEED** button after the printer starts flashing RED. The printer calibrates the ribbon sensor.
4. To resume normal printing, turn off the printer, wait two seconds, then turn it back on again.

Adjusting the Black Mark/Die Cut Sensor

The printer has a black mark/die cut sensor, which it uses to sense and properly calibrate supplies. Black mark supply has sense marks (black marks) on the back of them. Die cut supply does not have any black marks.

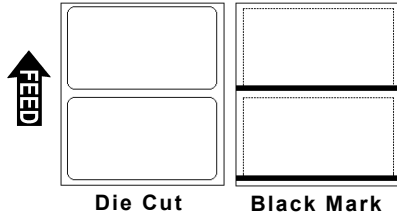

For die cut supplies, make sure the sensor is in the detented position and the middle of the square lens lines up with the arrow inside the printer.

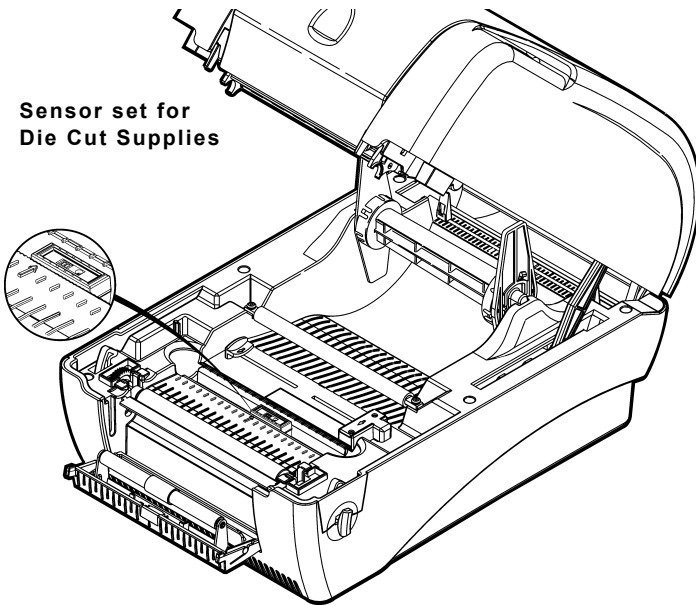

For black mark supplies, if necessary, move the sensor to the left or right, depending on where the black marks are on the supplies. The black marks on the supply should cover the square lens inside the sensor.

3-16 Loading Supplies

PRINTING

4

This chapter describes how to print.

Before you print, make sure the printer is connected to the host with a communication cable. The communication values at the printer must match those at the host.

The printer's default communication values are 9600 Baud, no parity, 8-bit data frame, 1 stop bit, and DTR flow control (96, N, 8, 1, DTR).

1. Turn on the printer.
2. Download a format and a batch. Refer to the *Packet Reference Manual* for information on downloading print jobs.
3. The printer prints the labels, either in peel mode or non-peel mode.
4. Remove the printed labels.

4-2 Printing

CARE AND MAINTENANCE

5

This chapter tells you how to

- ◆ clear supply jams
- ◆ clean the printhead
- ◆ clean the platen roller and printer.

Clearing Supply Jams

When you are printing and a jam occurs, the indicator light turns RED. To clear the jam:

1. Turn off the printer. Press the switch on the back of the printer to the OFF position (O).

You should turn off the printer's power before you clear a supply jam. If you need to clear a supply jam during a print job, you may lose your data when you turn off the printer.

2. Press the release levers towards the front of the printer to release the supply door.
3. Lift open the supply door. The supply door support at the right-hand rear of the printer holds the supply door open.
4. If necessary, remove any previously loaded supply. Lift up the supply holder and remove one of the supply holder guides.
5. Slide the supply off the holder.

6. Remove the jammed supply.

CAUTION

Do Not use sharp or pointed objects to remove supply, or damage to the printhead may occur.

7. Reload the supply. See Chapter 3, "Loading Supplies."
8. Close the supply door by lifting the supply door slightly and pulling the bottom of the supply door support forward towards the front of the printer. Close the supply door slowly and make sure it latches securely.

If you do not latch the supply door completely, poor print quality may result.

9. Press the **FEED** button to clear the error. The indicator light should be GREEN.

Cleaning the Printhead

Clean the printhead whenever you notice a decline in print quality, or after using three rolls of supply.

You must turn off the printer's power before you clean the printhead. If you need to clean the printhead during a print job, you may lose your data when you turn off the printer.

1. Turn off the printer. Press the switch on the back of the printer to the OFF position (O).
2. Press the release levers towards the front of the printer to release the supply door.

5-2 Care and Maintenance

- 3.** Lift open the supply door. A supply door support at the right-hand rear of the printer holds the supply door open.
- 4.** Moisten a cotton swab with isopropyl alcohol.
- 5.** Rub the cotton swab across the printhead to remove any build-up.

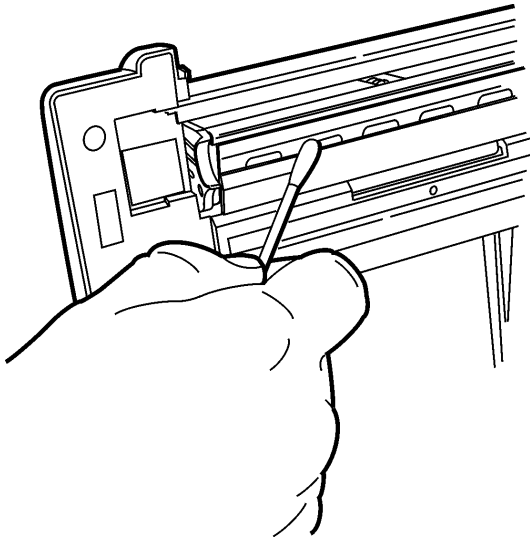

- 6.** Allow the printhead to dry for one minute before you close the supply door and resume printing.

Cleaning the Platen Roller and Printer

Moisten a cotton swab with isopropyl alcohol and run the cotton swab across the platen roller. Turn the platen roller with your finger and make sure it is clean all the way around.

NOTE: Do Not remove the platen roller.

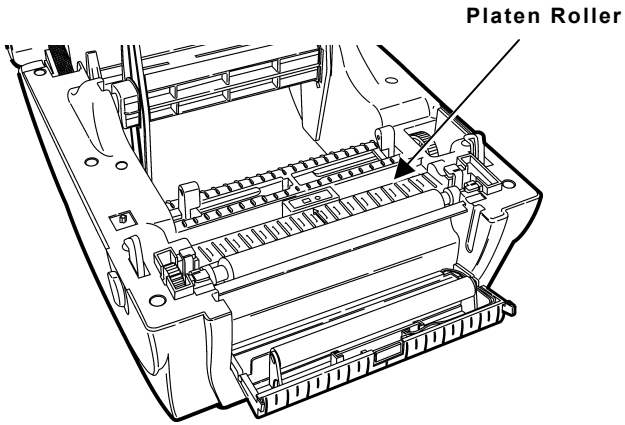

- ◆ Slightly dampen a cloth with water and wipe the exterior surfaces clean.
- ◆ Use a dry, soft-bristled brush to clean paper dust out of the interior.

TROUBLESHOOTING

6

This chapter includes information on

- ◆ possible printing problems and solutions
- ◆ printing test labels
- ◆ calibrating the supply and the ribbon.

Printing Problems and Solutions

Problem	Action
Indicator light is off when the printer is turned on.	Check the power connections from the power supply to the printer and the AC outlet. See "Connecting the Power Supply" in Chapter 1 for more information.
Indicator light is GREEN, but the printer does not print.	Check the cable connections from the host to the printer. "Connecting the Communication Cable" in Chapter 1 for more information.
	Make sure the ribbon and supply are loaded correctly. See Chapter 2, "Loading A Ribbon," and Chapter 3, "Loading Supplies," for more information.
	Clean the printhead. See "Cleaning the Printhead" in Chapter 5 for more information.
	Make sure the supply door is closed completely.

Problem	Action
<p>Printing stops and indicator light turns RED.</p> <p>Or,</p> <p>Printing is not lined up correctly on supply.</p>	<p>Calibrate the supply.</p> <ol style="list-style-type: none"> 1. Turn off the printer. 2. Load supply for non-peel mode. See Chapter 3, "Loading Supplies," for more information. 3. Press and hold the FEED button while turning on the printer. 4. Release the FEED button after the indicator light starts flashing ORANGE. The printer calibrates the black mark or die cut sensor, measures the label length, prints the test labels, and calibrates the ribbon sensor. 5. To resume normal printing, turn off the printer, wait two seconds, then turn it back on.
	<p>Problem with the supply. Load different supply. See Chapter 3, "Loading Supplies" for more information.</p>
	<p>Make sure the ribbon is not empty.</p>
	<p>Make sure the black mark/die cut sensor is set correctly for your supply type. See "Adjusting the Black Mark/Die Sensor," for more information.</p>
	<p>Clear a label jam. See "Clearing Supply Jams," in Chapter 5 for more information.</p>

6-2 Troubleshooting

Problem	Action
Printing is faded or poor quality.	Make sure the supplies and ribbon are loaded correctly. See Chapter 2, "Loading Ribbon," and Chapter 3, "Loading Supplies" for more information.
	Clean the printhead. See "Cleaning the Printhead" in Chapter 5 for more information.
	Check the supplies and ribbon for damage or defects. Reload supplies or ribbon if necessary.
	Ribbon and supply are not compatible. For thermal direct supplies, do not load a ribbon.
	Adjust the print speed/darkness (contrast). Refer to the <i>Packet Reference Manual</i> , for more information.
Supply exits partially out of the printer or skips.	Supply might be caught in the printer. See "Clearing Supply Jams" in Chapter 5 for more information.
	Make sure the supplies and ribbon are loaded correctly. See Chapter 2, "Loading Ribbon," and Chapter 3, "Loading Supplies" for more information.
	For thermal transfer printing, make sure thermal transfer (requires a ribbon) supply is loaded. For thermal direct printing, make sure thermal direct (does not require a ribbon) supply is loaded.
Ribbon is installed but is not advancing when printing.	See "Calibrating the Supply" to calibrate the ribbon sensor.

Printing Test Labels

To print the test labels:

1. Turn off the printer.
2. Press and hold the **FEED** button while turning on the printer.
3. Release the **FEED** button after the indicator light starts flashing **ORANGE**. The test labels print.

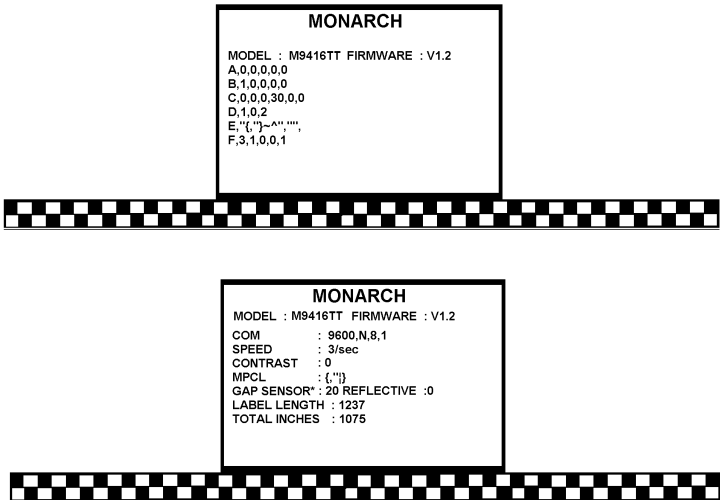

The first label shows the printer's configuration by packet (A-F). Refer to the *Packet Reference Manual* available on our Web site for more information.

The second label shows the model number, software version, communication settings, speed, contrast, gap sensor setting, label length, and total number of inches printed.

4. To resume normal printing, turn off the printer, wait two seconds, then turn it back on again.

6-4 Troubleshooting

Calibrating the Supply

1. Turn off the printer.
2. Press and hold the **FEED** button while turning on the printer.
3. *To calibrate the supply*, release the **FEED** button after the indicator light starts flashing **ORANGE**. The printer calibrates the black mark or die cut sensor, measures the label length, and prints the test labels.
To calibrate the ribbon, release the **FEED** button after the printer starts flashing **RED**. The printer calibrates the ribbon sensor.
4. To resume normal printing, turn off the printer, wait two seconds, then turn it back on again.

6-6 Troubleshooting

SPECIFICATIONS AND ACCESSORIES



This chapter includes printer, supply, and ribbon specifications. It also lists the printer's accessories.

Printer Specifications

Height:	7.4" (188 mm)
Width:	8.4" (213 mm)
Depth:	12.4" (315 mm)
Weight:	6.3 lbs. (2.9 kg) without power supply
Shipping Weight:	12 lbs. (5.4 kg)
Power:	AC Input: 100-240 V 50-60Hz DC Output: 18-24 V
Operating Limits:	Operation: 40° to 105° F (4° to 40° C) Storage: 40° to 140° F (4° to 60° C) Relative Humidity: 5% - 90% (non-condensing)
Printhead:	4.09" (104 mm) 203 dpi (8.0 dots per mm) 300 dpi (11.82 dots per mm)
Printing Method:	Thermal Direct and Thermal Transfer

Supply Specifications

Supply Types: Labels, tags or receipt paper

Supply Widths: 0.75" (19 mm) minimum
4.25" (108 mm) maximum

Supply Lengths: 0.25" (6.3 mm) minimum
10.0" (254 mm) maximum

(for peel): 0.75" (19 mm) minimum
10.0" (254 mm) maximum

NOTE: Hold the leading edge of peeled labels when printing on supply longer than six inches.

Ribbon Specifications

Types: Standard

Core Diameter: Inside: 1.0" (25.4 mm)
Outside: 1.5" (38 mm)

Width: 1.6" (41 mm) minimum
4.3" (109 mm) maximum

Length: 300 meters

Printer Accessories

Use these part numbers when ordering parts.

Description	Part Number
Centronics® Cable (IEEE 1284-B to 25-pin male)	118363
Serial Cable 6' (DB 9-pin male to DB 9-pin female)	300017-006
Parallel Cable 6' (DB 25-pin female to DB 9-pin male)	300018-006
USB V2.0 Cable (male)	125323

Visit **www.monarch.com** for sales, service, supplies, information, and telephone numbers for our locations throughout the world.

TOLL FREE:

1-800-543-6650 (In the U.S.A.)

1-800-363-7525 (In Canada)

Free Manuals Download Website

<http://myh66.com>

<http://usermanuals.us>

<http://www.somanuals.com>

<http://www.4manuals.cc>

<http://www.manual-lib.com>

<http://www.404manual.com>

<http://www.luxmanual.com>

<http://aubethermostatmanual.com>

Golf course search by state

<http://golfingnear.com>

Email search by domain

<http://emailbydomain.com>

Auto manuals search

<http://auto.somanuals.com>

TV manuals search

<http://tv.somanuals.com>