

# Quick Reference

## Monarch<sup>®</sup> 9855<sup>®</sup> RFID Printer

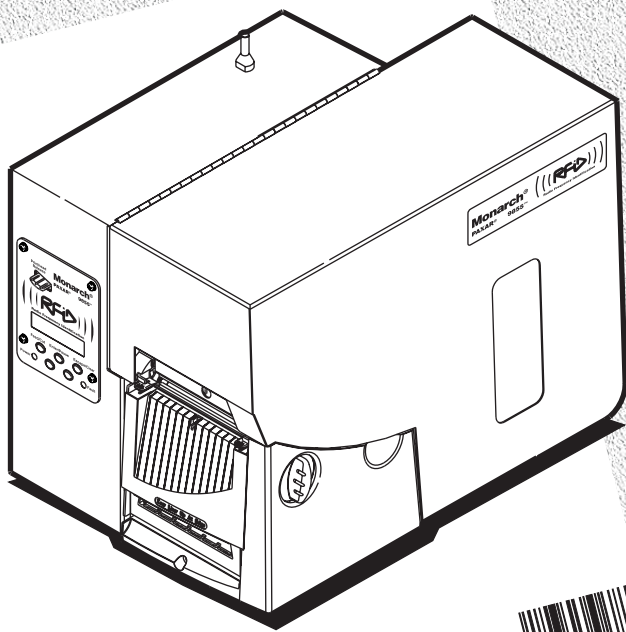

Each product and program carries a respective written warranty, the only warranty on which the customer can rely. Paxar reserves the right to make changes in the product, the programs, and their availability at any time and without notice. Although Paxar has made every effort to provide complete and accurate information in this manual, Paxar shall not be liable for any omissions or inaccuracies. Any update will be incorporated in a later edition of this manual.

©2007 Paxar Americas, Inc. a subsidiary of Avery Dennison Corp. All rights reserved. No part of this publication may be reproduced, transmitted, stored in a retrieval system, or translated into any language in any form by any means, without the prior written permission of Paxar Americas, Inc.

#### **WARNING**

This equipment has been tested and found to comply with the limits for a Class A digital device, pursuant to Part 15 of the FCC Rules. These limits are designed to provide reasonable protection against harmful interference when the equipment is operated in a commercial environment. This equipment generates, uses, and can radiate radio frequency energy and, if not installed and used in accordance with the instruction manual, may cause harmful interference to radio communications. Operation of this equipment in a residential area is likely to cause harmful interference in which case the user will be required to correct the interference at his own expense.

#### **CANADIAN D.O.C. WARNING**

This digital apparatus does not exceed the Class A limits for radio noise emissions from digital apparatus set out in the Radio Interference Regulations of the Canadian Department of Communications.

Le présent appareil numérique n'émet pas de bruits radioélectriques dépassant les limites applicables aux appareils numériques de la classe A prescrites dans le Règlement sur le brouillage radioélectrique édicté par le ministère des Communications du Canada.

#### **Radio Frequency Interference Requirements**

This device complies with part 15 of the FCC Rules. Operation is subject to the following two conditions: (1) This device may not cause harmful interference, and (2) this device must accept any interference received, including interference that may cause undesired operation.

#### **Trademarks**

Monarch® and 9855 are trademarks of Paxar Americas, Inc.

Avery Dennison® is a trademark of Avery Dennison Corp.

EPCglobal, Inc.™ and Electronic Product Code™ (EPC) are trademarks of Uniform Code Council, Inc. Uniform Code Council, Inc.® is a trademark of Uniform Code Council, Inc.

Avery Dennison Printer Systems Division  
170 Monarch Lane  
Miamisburg, OH 45342

Visit **[www.monarch.com](http://www.monarch.com)** for sales, service, supplies, information, and telephone numbers for our International locations.

TOLL FREE:

**1-800-543-6650 (U.S.A.)**

**1-800-363-7525 (Canada)**



## Introduction

---

This *Quick Reference* contains supply loading and general maintenance procedures. Additional RFID documents are available on the enclosed CD-ROM and on our Web site ([www.monarch.com](http://www.monarch.com)).

**Note:** Information in this document supercedes information in previous versions. Check our Web site for the latest documentation and release information.

## RFID Overview

---

Your printer has been engineered to program (encode) an RFID (Radio Frequency Identification) label (commonly called “RFID tags”) before the label's format is printed. RFID tags contain an embedded RFID inlay (chip and antenna).

RFID is only available on the Monarch® 9855™ printer using die cut or black mark supplies. Linerless supplies are not currently supported. The RFID printer is also capable of printing standard (non-RFID) supplies. For more information about supplies, see “RFID Supply Specifications.”

The UHF printer supports multi-protocol encoding, including Class 1 Generation 1 (C1Gen1), Class 1 Generation 2 (C1Gen2), and EM4122 supplies.

The HF printer supports multi-protocol encoding, including ISO15693 and I•CODE® UID protocols.

## About Professional Services

---

Our Professional Services group can develop custom RFID scripts (applications) or other types of data manipulation scripts. Our experts can ensure your RFID requirements are met. Custom programming can be factory-loaded at the time of shipment. Call Customer Service for more information.

# Web Sites with RFID Information

---

## **AIM Global**

The association for Automatic Identification and Mobility.

[www.aimglobal.org](http://www.aimglobal.org)

## **EPCglobal, Inc.™**

A joint venture between EAN International and the Uniform Code Council, Inc., creating RFID standards for the Electronic Product Code™ (EPC).

[www.epcglobalinc.org](http://www.epcglobalinc.org)

## **RFID Journal**

An independent media company specializing in RFID.

[www.rfidjournal.com](http://www.rfidjournal.com)

## **Uniform Code Council, Inc.®**

A global standards organization in supply chain management.

[www.uc-council.org](http://www.uc-council.org)

## **Avicon**

Provides software to translate legacy codes to electronic product codes (EPC) for Class 1 96-bit (and more) representations.

[www.epctranslator.com](http://www.epctranslator.com)

# Connecting the Cables

---

The power supply automatically switches between 115V or 230V. There are no operator settings required.

1. Plug the power cable into the socket. Plug the other end of the cable into a grounded electrical outlet.
2. Connect the communication cable into the appropriate port. Secure the cable with the connecting screws (serial) or spring clips (parallel).

If you are communicating with the host through the serial port, make sure the printer's communication values match those at the host. The factory default values are 9600 Baud, 8 bit data frame, 1 stop bit, no parity, and DTR flow control (9600, N, 8, 1, DTR). Set the communication values on the printer to match those at the host.

The printer also has a USB (Universal Serial Bus) version 2.0 communications port, which is compatible with version 1.1.

Drivers are available on our Web site for a variety of operating systems.

3. Turn on the printer. Press ( I ) to turn on and ( O ) to turn off the printer.

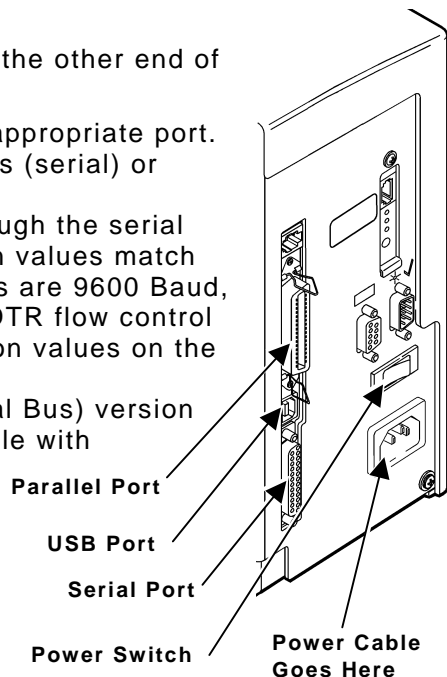

## Using the Control Panel

The control panel has a two-line LCD display, two status lights, and five buttons. The control panel displays error codes/messages, and allows you to setup/configure the printer.

- Power:** The printer shows a steady green light when it is on.
- Fault:** The printer shows a steady amber light when it is out of labels or ribbon, or when you have a supply jam.
- Feed/Cut:** Prints a label in the on-demand mode, feeds a blank label if there is no print job, and prints a label with error information that is useful to your System Administrator if an error is displayed. When the printer is offline, changes the displayed value by one or ten.
- Enter/Pause:** Pauses the current print job or resumes a paused print job. Selects the displayed menu item.
- Escape/Clear:** When an error is present, clears the error. When a job (batch) is printing, cancels the print job (batch). Enters the offline menu mode or returns the display to the next higher menu.
- ← Displays the previous menu item.
- Displays the next menu item.
- ← and → Prints a test label when you press the buttons at the same time. Hold for one second and release.

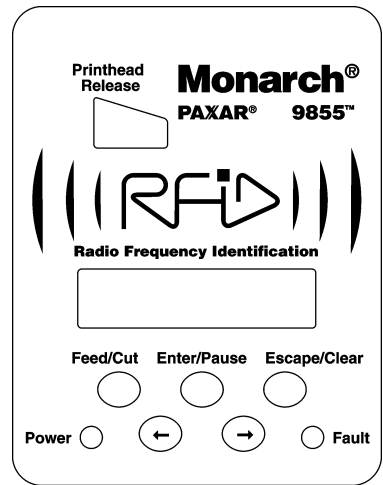

## Loading RFID Labels



The RFID supplies are sensitive to static electricity and can be damaged by static electricity. Ground yourself by touching some metal, such as the printer's metal base, before handling the supplies.

Refer to the *9855 Operator's Handbook* for additional supply loading instructions if using non-RFID supplies in your RFID printer.

1. Open the cover.
2. Unlock the printhead by turning the retaining latch.
3. Lift the printhead assembly using the printhead tab until the assembly locks into place.

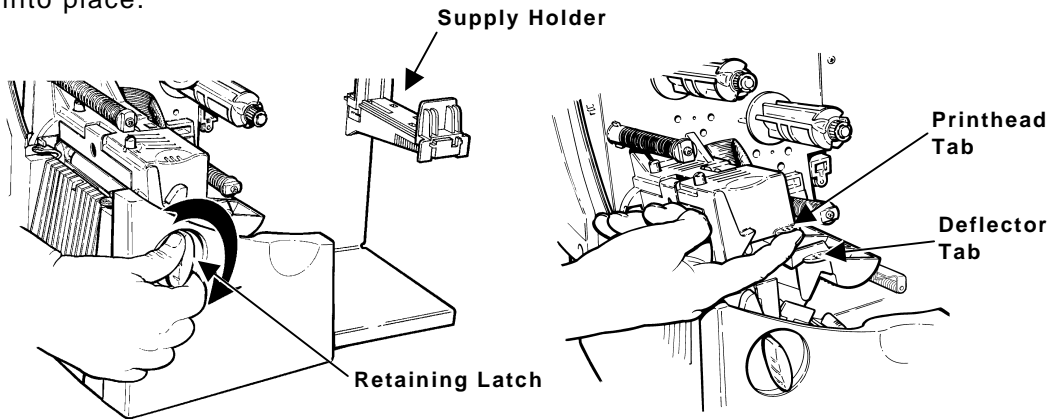

4. Place the roll of supply on the supply holder. For labels, the supply unrolls from the top or the bottom. **Do not pick up the printer by the supply holder.**

5. Adjust the supply holder guides so the sides barely touch the roll. Make sure the supply roll turns freely.  
**If you are using fan-fold supplies**, place the supply stack behind the printer, label side facing up.

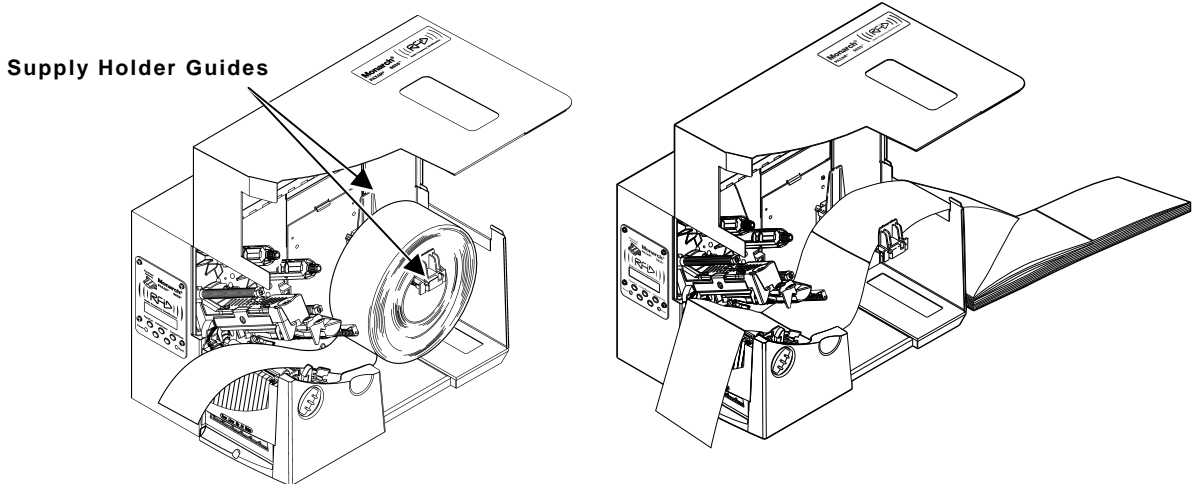

6. Push down on the supply lever to unlock the supply guides.
7. Lay the label strip across the supply guide so that a few inches extend past the front of the printer. Tuck the supply under the nibs and in between the die cut sensor. *Do not feed supply between the supply roller and deflector.*  
**For fan-fold supplies**, lay the label strip over the supply holder and across the supply guide so that a few inches extend past the front of the printer. Tuck the supply under the nibs and in between the die cut sensor.
8. **For tag supplies using the optional knife**, feed the supply through the knife. Make sure at least 0.5 inches of supply is past the knife.

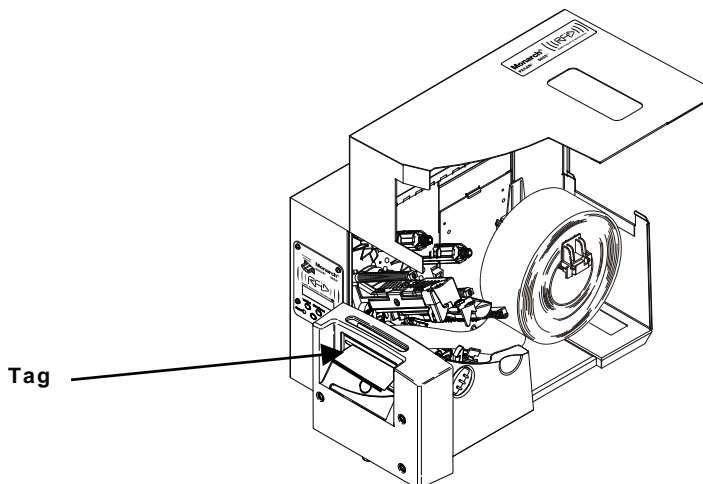

9. Adjust the supply guides so they touch the supply. Push up on the supply lever to lock the supply guides into place.

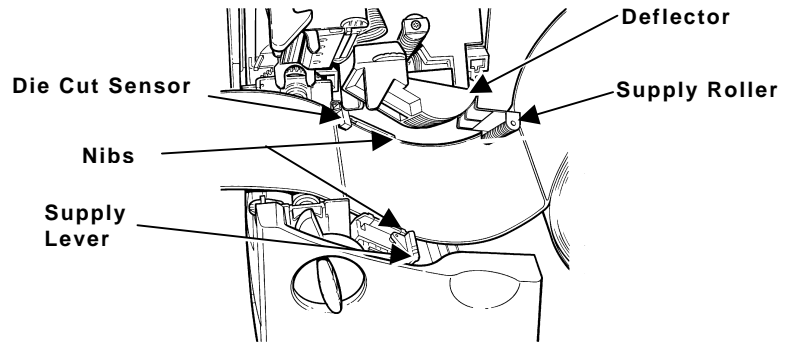

10. Hold the printhead assembly by the printhead tab while pressing down on the printhead release.

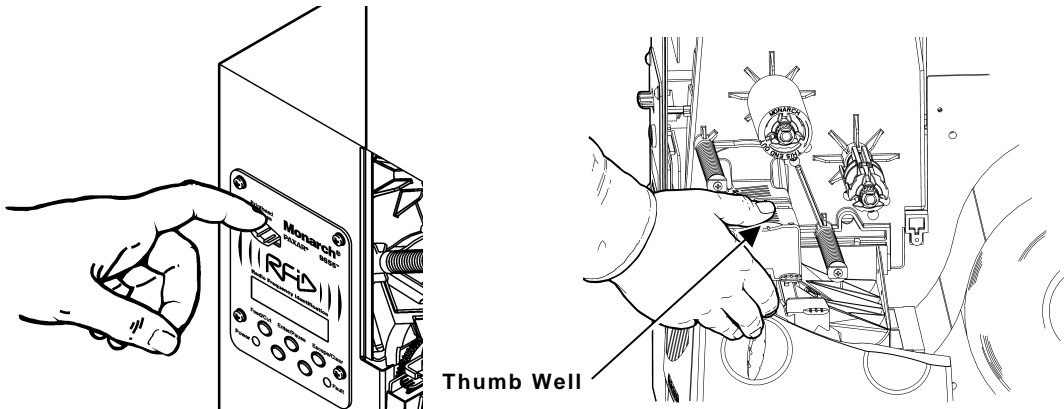

11. Close the printhead by pressing down on the thumb well until you hear it click into place.
12. Press **Feed/Cut** several times to feed at least three labels/tags to properly position the supply and the ribbon.



## Loading Labels for the Optional Peel Mode

Peel mode (on-demand) must be purchased separately. In peel mode, the printer separates the backing paper from the label. The next label is not printed until the completed one is removed from the printer. Make sure the printer is configured for on-demand mode and the correct supply type is installed. The minimum feed length is 1.5 inches for peel mode. Hold the leading edge of peeled labels when printing labels longer than six inches. You must use non-perforated supplies for peel mode. Follow the steps for loading supplies from the previous section. Then, follow these steps after you close the printhead.

1. Remove the labels from the first 10 inches of the backing paper.
2. Press down on the exit cover tabs to open the exit cover on the front of the printer.

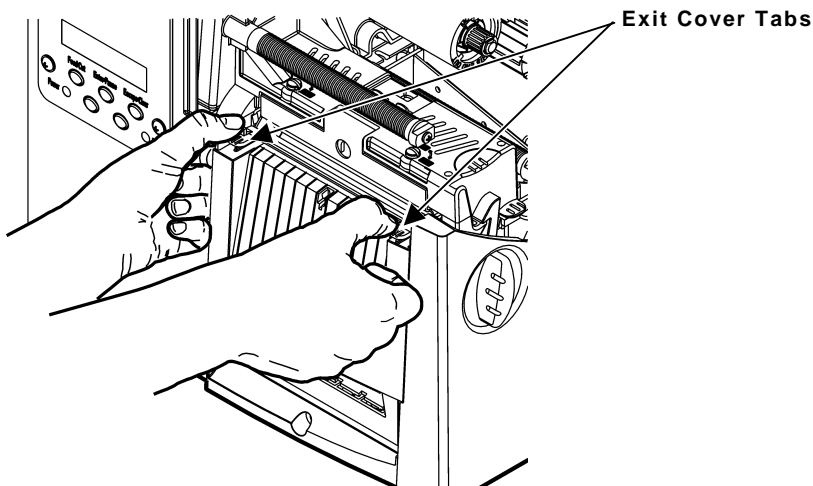

3. Feed the backing paper over the peel bar.

4. Feed the backing paper through the lower opening of the exit cover. Close the exit cover. Pull down on the backing paper to remove any slack.

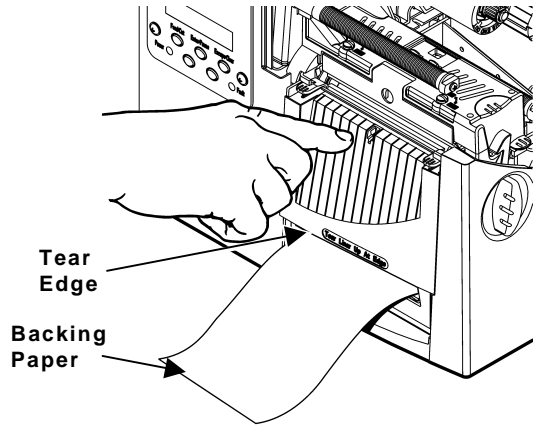
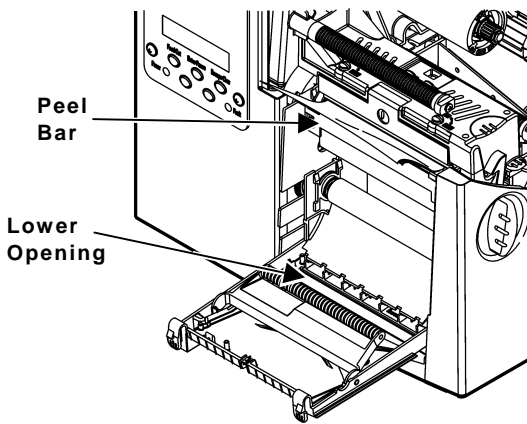

**When removing the backing paper, pull up across the saw-toothed tear edge.** Make sure the backing paper tears at the edge.

5. Close the printer's cover.
6. Press **Feed/Cut** several times to feed at least three labels/tags to properly position the supply and the ribbon.

## Adjusting the Wide/Narrow Knobs

---

You may need to adjust the two wide/narrow knobs according to the width of your supply. For supply that is more than two inches, adjust the knobs to the wide setting. For supply that is two inches or less, adjust the knobs to the narrow setting.

You must adjust both of the knobs to the same position.

If you experience ribbon smudging in cold, dry environments, adjust the wide/narrow knobs to the wide setting.

For wide supplies, push down and turn the wide/narrow knobs clockwise with a screwdriver.

For narrow supplies, turn the wide/narrow knobs counter-clockwise with a screwdriver until it pops back up.

The adjustment is shown in the wide position.

**Wide/Narrow Knobs**

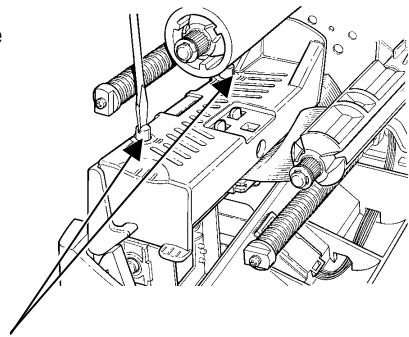

# Loading Ribbon

1. Open the cover.
2. Unlock the printhead by turning the retaining latch.
3. Lift printhead assembly using the printhead tab until the assembly locks into place.
4. Push the deflector tab down.
5. Slide the extra ribbon core on the take-up reel as far as it will go with the "This End Out" writing facing out. Use your empty ribbon core as the take-up core. The take-up core only fits on the take-up reel one way.
6. Remove the new ribbon from the package. Do not wrinkle or crush the new ribbon.
7. Slide the ribbon onto the back reel as far as it will go. The ribbon roll only fits on the reel one way. Carefully unwind a few inches of ribbon from the bottom of the roll.

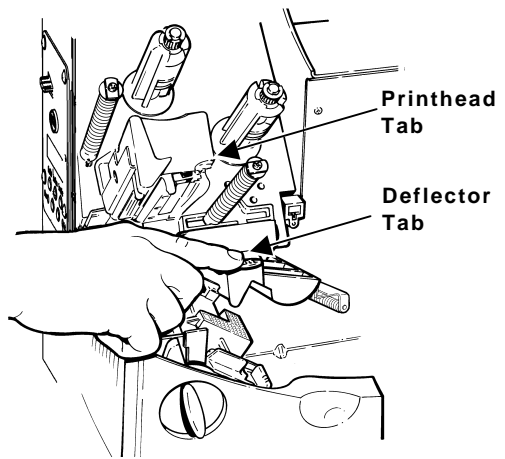

**Note:** Make sure the "Monarch This End Out" writing is facing out. The ribbon roll only fits on the reel one way.

8. Carefully feed the ribbon under both ribbon rollers and printhead.
9. Align the ribbon and make sure it is straight and centered throughout the path.
10. Tape the ribbon to the take-up core. Do not tape the ribbon to the take-up reel.
11. Rotate the take-up core until the leader is past the printhead.
12. Remove any slack in the ribbon by turning the take-up reel clockwise.
13. Hold the printhead assembly by the printhead tab while pressing down on the printhead release.
13. Close the printhead by pressing down on the thumb well until you hear it click into place. Close the cover. Press **Feed/Cut** several times to feed at least three labels/tags to properly position the supply and the ribbon.

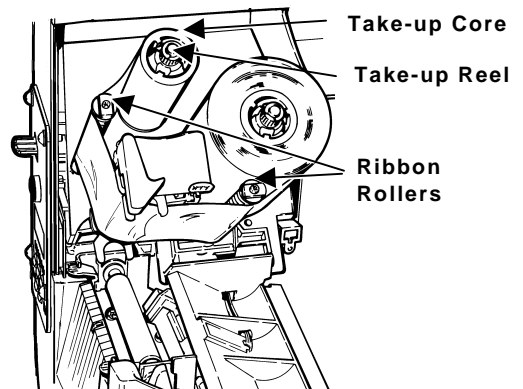

# Adjusting the Print Contrast

---

The print contrast controls the darkness of the printing on your supply.

1. From the **Main Menu**, select **Setup**, then **Contrast**.

You see the current setting, for example:

Enter contrast  
[-699/699]: +0

2. Press **←** or **→** to change the contrast. Pressing **→** darkens the print; **←** lightens the print. **Feed/Cut** acts as a toggle switch to change the value by 10 or 1. For example, to make the contrast 50 (from the default 0), press **Feed/Cut**, then press **→** five times (50). Press **Enter/Pause** to select the displayed value.

Test Label?  
No →

3. Press **←** or **→** to select either “Yes” or “No” to print a test label and check the print contrast. Press **Enter/Pause**.
4. Press **Escape/Clear** until you see the Main Menu.

## Printing

---

Before you print, make sure the printer is connected and ready to receive data.

When you turn on the RFID printer, “Monarch Initializing” flashes briefly and then you see “Print Mode Ready.” If an error occurs while the printer is initializing, the error message flashes briefly on the display and then you see “Print Mode Ready.” The printer displays “Not available” when you try to select the RFID menus if the module is inoperative.

The printer accepts RFID and non-RFID batches once you see “Print Mode Ready.”

1. Download a format and a batch. Refer to the optional Packet Reference Manual for information on downloading print jobs.
2. The printer prints a strip of labels or labels in on-demand mode. If printing RFID supplies, you see

RFID Printing...  
1 of 10

If the RFID tag is not programmable for any reason, the label may print with an overstrike pattern, indicating that it should not be used. Your System Administrator should set the desired Error Action accordingly.

When printing on non-RFID supplies, you may also see a label with an overstrike pattern. Do not use that label. When using “overstrike” as the Error Action, the data prints on the non-RFID label, but there is no data printed on the RFID label.

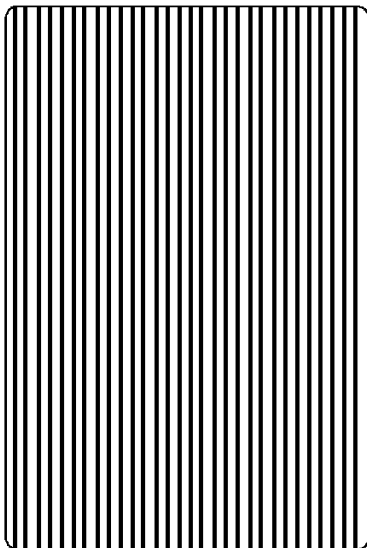

RFID Overstrike

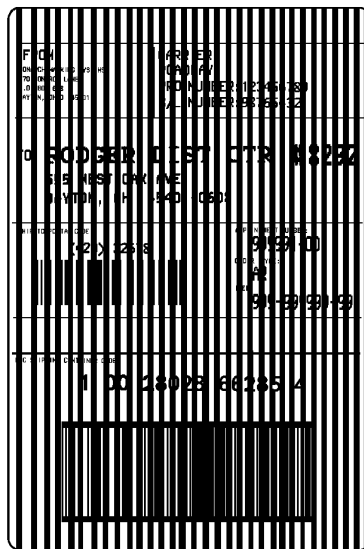

Non- RFID Overstrike

**Note:** The RFID printer pauses while programming the RFID tag.

3. Remove the printed labels. If the printer will be unused for extended periods of time, we recommend leaving the printhead unlatched.

## Menu Changes

---

Some changes were made to the menu structure for RFID. These menus should only be accessed by your System Administrator. Refer to the *RFIDMP (Multi-Protocol) Application Notes* or the *HF (High Frequency) Application Notes* available on our Web site for more information.

## Clearing Jams

---

When you are printing and a jam occurs, the **Fault** light on the printer's front panel blinks.

1. Turn off the printer and open the cover and printhead assembly.
2. If necessary, remove the label roll and ribbon.
3. Remove the jammed labels and reload the label roll.
4. Close the printhead assembly and turn on the printer.
5. Press **Feed/Cut** several times to feed at least three labels/tags to properly position the supply and the ribbon.

## Cleaning

---

**CAUTION:** Do not use sharp objects to clean the printhead or touch the printhead. This may damage the printhead and require a service charge.

**Note:** You **must** clean the printhead as described below to maintain printhead life.

The rate and frequency at which you print determines how often you must clean the printer. You may need to clean the printhead, sensor, and platen roller:

- ◆ if there is any adhesive build-up in the supply path.
- ◆ after printing approximately three rolls of thermal transfer/thermal direct supplies or after each ribbon.
- ◆ daily if your printer is in an excessively dirty, hot, or humid environment.
- ◆ if you frequently receive supply error codes or when you see voids or streaking in the print as shown.

1. Turn off the printer and open the cover and printhead assembly.
2. Remove the label roll and ribbon (when cleaning the printhead).
3. Press down on the exit cover tabs to open the exit cover on the front of the printer.



4. Clean the platen roller when you see significant adhesive build-up or a label is wrapped around the platen roller. Use a dry, soft-bristle brush, such as a toothbrush, to clean the platen roller.

If the brush does not remove all the adhesive, use isopropyl alcohol on the platen roller. Moisten a cotton swab with isopropyl alcohol and run the cotton swab across the platen roller. Turn the platen roller with your finger to make sure the platen roller is clean all the way around. After cleaning, feed several inches of supply through without printing to remove any remaining isopropyl alcohol.

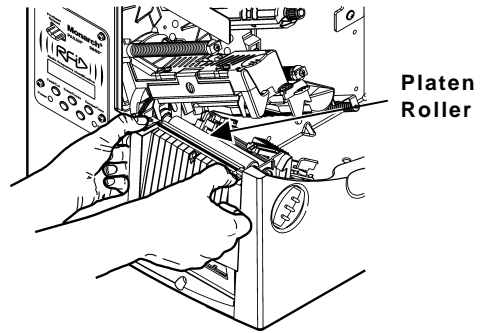

5. Rub the cotton swab moistened with isopropyl alcohol across the peel bar and remove any build-up.
6. Moisten another cotton swab with isopropyl alcohol. Rub the cotton swab across the printhead and remove any build-up. You may need to use a printhead CLEAN-STRIP if the printhead is extremely dirty or you see streaks on the supply.

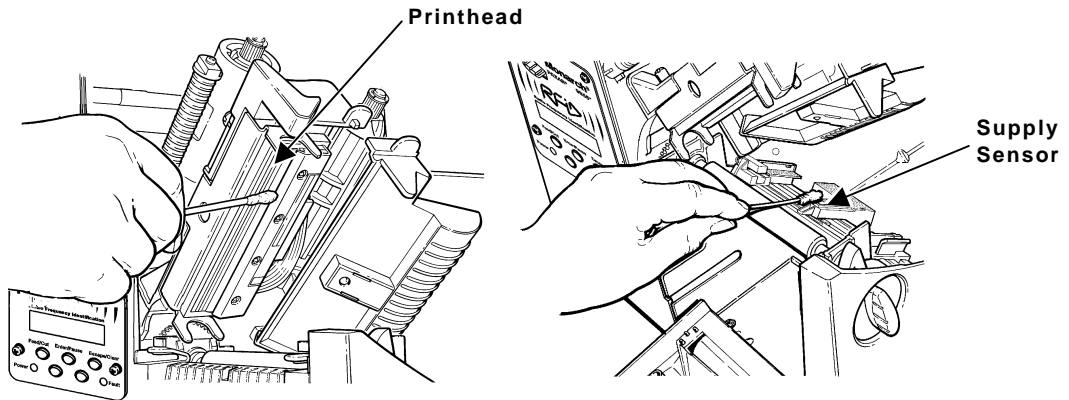

7. Rub the cotton swab across the supply sensor and die cut sensor and remove any build-up.
8. Clean the build-up in the supply path.
9. Let the printer dry before you reload supplies.

10. Push on the exit cover firmly to close it. Both latches will click into place.
11. Close the cover and printhead assembly.
12. Turn on the printer and press **Feed/Cut** several times to feed at least three labels/tags to properly position the supply and the ribbon. Resend your format, batch, and check digit packets.

## Troubleshooting

---

This section provides solutions to minor printing problems.

<b>Problem</b>	<b>Action</b>
Error message appears during startup	Turn OFF the printer, wait fifteen seconds and then turn ON the printer. Call Service if the error message reappears.
Does not print.	Check supply. Check ribbon. Send a corrected format and batch packet.
Does not feed.	Set wide/narrow knobs correctly.
Partially printed data.	Clean the printhead. Send a corrected format packet.
Printing shadows or smears.	Clean the printhead. Change supply. Check ribbon.
Light Printing.	Change supply. Adjust the print contrast. Check wide/narrow knobs. Check ribbon.
Heavy Printing.	Clean the printhead. Change supply. Adjust the print contrast. Check wide/narrow knobs. Check ribbon.
Voids in printing.	Clean the printhead. Change supply type. Check ribbon.
Serial bar codes do not scan.	Leave printhead unlatched when not in use. Use a print speed of 2.5 IPS. Adjust the print contrast.
Backing paper is wrapped around platen or peel roller.	Carefully remove the backing paper. Make sure the backing paper tears at the saw-toothed tear edge when using backfeed and peel mode.



<b>Problem</b>	<b>Action</b>
Blank labels print or 750 series errors.	Clean supply sensors.
Printer does not read or program the RFID tag.	See your System Administrator. Make sure the following are set correctly for your inlay (RFID tag) type: Protocol (C1Gen1, EM4122), Read Power, and Write Power. Refer to your <i>RFID Setup Guide &amp; Supply Chart</i> or <i>HF Setup Guide &amp; Supply Chart</i> for more information.

## Common Errors

If the action does not resolve the problem, call Service at the number listed on the inside front cover of this manual.

### **Error Description/Action**

- 002** Name must be 1 to 8 characters inside quotes.
- 005** Supply width is invalid.
- 018** Code page selection defined in the field is invalid.
- 025** Data length is too long.
- 052** Data type in the RFID Data Field must be 0, 1, 2, or 3. See your System Administrator for more information.
- 053** The starting block in the RFID Data Field is invalid.
- 101** Format referenced by batch not in memory.
- 226** Rule Record Line xx. Upload device must be H (Host) for Option 6.
- 228** Memory class identifier is invalid. The identifier must be A (AFI), D (DSFID), or E (EAS) for Option 64. For more information, refer to the *HF Application Notes*.
- 229** Byte code is invalid. Byte code must be an 8-bit (1 byte) character for Option 64. For more information, refer to the *HF Application Notes*.
- 230** Lock code is invalid. Lock code must be 0 (Unlock) or 1 (Lock) for Option 64. For more information, refer to the *HF Application Notes*.
- 400** Invalid character following {.
- 403** Field separator was not found.
- 409** Printer memory is full. Delete unnecessary formats or graphics from memory.
- 410** Parity mismatch.
- 411** Framing error (baud rate mismatch).

- 412** Flow control mismatch.
- 413** Online receive buffer is full. Check for a flow control problem.
- 611** Font, bar code, or density in the batch does not fit the format.
- 612** The data in this line of the batch is either missing or does not match the format.
- 613** Reference point off supply.
- 614** Portion of field off supply or there may be an invalid character in the packet.
- 703** The printer sensed a calibration of different-sized black marks. Make sure the correct supply type is loaded.
- 704** Printer has not sensed a supply mark when expected or is out of supplies. Press Escape/Clear and try to continue printing. Change supply.
- 715** Invalid data length/data mismatch. The data in the RFID Data Field has an incorrect data length or there is a data type mismatch between selected data type and actual data entered. For more information about the data length and data type, refer to the *RFIDMP Application Notes* or the *HF Application Notes*. This error also occurs when there is an error in the Expanded C1Gen2 fields. Check with your System Administrator about your format.
- 740** Command, hardware, inventory, or memory allocation error. There may be an RFID hardware or memory allocation error.
- 741** RFID tag missing. Tag not found in RF Field. The RFID tag was not found in the RF Field (area inside the printer where RFID tag is programmed.) Check supply loading. If you made supply or print position settings, make sure the RFID tag was not moved out of the programmable range.
- 742** Tag erase failed. The RFID tag was found in the RF Field, but could not be erased. Increase the number of retries. For more information, refer to the RFIDMP Application Notes or the HF Application Notes.
- 743** Program tag failed. The RFID tag was found in the RF Field, but could not be programmed. Increase the number of retries. For more information, refer to the RFIDMP Application Notes or the HF Application Notes.
- 744** Tag locked fail. The RFID tag is unable to be programmed because it is already locked. This is considered a bad RFID tag. For more information, refer to the RFIDMP Application Notes or the HF Application Notes.

- 746** Lock tag fail. The RFID tag has not been locked to prevent reprogramming. This is considered a bad RFID tag. For more information, refer to the *RFIDMP Application Notes* or the *HF Application Notes*.
- 747** Time out failure. An RFID command (read, program, etc.) has failed to complete in the maximum amount of allowed time.
- 748** Invalid data length/data mismatch from RFID interrogator module. The RFID interrogator module found a problem with the data received from the printer. For more information, refer to the *RFIDMP Application Notes* or the *HF Application Notes*.
- 749** RFID Verify Fail. The RFID verification process failed after writing (programming) tag. This is considered a bad RFID tag. For more information, refer to the *RFIDMP Application Notes* or the *HF Application Notes*.
- 751** Printer did not sense a black mark when expected. Press Escape/Clear and try to continue printing. Change supply.
- 752** Printer sensed a mark in the wrong place.
- 753** Printer sensed a mark that is too long.
- 754** Check for a ribbon jam or remove any slack in the ribbon by turning the take-up reel clockwise. Load a new ribbon.
- 755** Printhead is open. Close the printhead.
- 756** Load supplies.
- 757** Load supplies (supply length mismatch). Press Feed/Cut.
- 758** Either the supply is not seen, the on-demand sensor is broken, or a label was removed too quickly. Check for a label jam or reload supplies.
- 763** Waiting to dispense label. Press Feed/Cut.
- 765** The printhead has less than 8 bad dots and can shift bar code fields to avoid bad dots. Press Escape/Clear to continue printing.
- 768** Printhead has more than 8 bad dots within the format area or is not connected. Replace or connect printhead as necessary.

The printer does **not** recalibrate (feed a blank label) after any RFID error. Refer to the *RFIDMP Application Notes* or the *HF Application Notes* (on our Web site) for more information.

## RFID Printer Specifications

---

<b>Height:</b>	13 inches (330 mm)
<b>Width:</b>	12.5 inches (318 mm)
<b>Depth:</b>	17.3 inches (439 mm)
<b>Weight:</b>	29 lb. (13.2 kg)
<b>Shipping Weight:</b>	34 lb. (15.5 kg)
<b>Power Source:</b>	90-132V <sub>AC</sub> with autoselect 50/60Hz 180-264V <sub>AC</sub> with autoselect 50/60Hz
<b>Printhead:</b>	Thermal at 4 inches (1012 mm) wide 203 dpi (8.0 dots per mm) Optional 300 dpi (11.8 dots per mm)
<b>Speed:</b>	2.5, 4.0, 6.0, 8.0, and 10.0 ips (inches per second). 12.0 ips (305 mm) printing is an option that must be purchased separately. 2.5 is the default for serial bar codes.
<b>Note:</b>	The RFID printer pauses while programming the RFID tag.

### Operating Temperatures

<b>Direct:</b>	40°F to 104°F (4°C to 40°C)
<b>Transfer:</b>	40°F to 95°F (4°C to 35°C)
<b>Storage:</b>	15°F to 120°F (-9°C to 49°C)
<b>Humidity:</b>	5% to 90% non-condensing

## RFID Supply Specifications

---

RFID supplies are available in a variety of sizes. Printing over the RFID inlay causes printing irregularity. Refer to the *RFID Setup Guide & Supply Chart* or the *HF Setup Guide & Supply Chart* for illustrations to determine which type of RFID supplies you are using and basic printer configuration information.

<b>Supply Types:</b>	Thermal Transfer or Thermal Direct Die Cut or Black Mark
<b>Supply Widths:</b>	0.75 inch (19 mm) minimum 4.0 inches (102 mm) maximum
<b>Supply Lengths:</b>	1.0 inch (25.4 mm) minimum 13.0 inches (330 mm) maximum <b>Note:</b> The supply length depends on the inlay selected.
<b>Roll Inside Diameter:</b>	4.0 inches (102 mm)
<b>Roll Outside Diameter:</b>	8.0 inches (203 mm) maximum
<b>Ribbon Width:</b>	4.3 inches (110 mm) for 4.0 inch (102 mm) supply
<b>Ribbon Length:</b>	23,600 inches (600 meters)

Additional RFID supplies may be available by request. Contact your RFID Representative for more information.

## Tag Cut Dimensions

---

Use these specifications for the 926™ Knife with the RFMP printer. Use only Monarch®/Paxar® approved RFID tag supplies.

<b>Widths:</b>	1.5 inches to 4.0 inches (38 mm to 102 mm)
<b>Lengths:</b>	1.5 inches to 16.0 inches (38 mm to 406 mm)
<b>Thickness:</b>	7 mils to 14 mils
<b>Batch Separator:</b>	3.66 inches (93 mm)
<b>Note:</b>	The limited warranty on knives used in or with RFID printers is one (1) year from the date of shipment, or 500,000 cuts, whichever occurs first.

## RF Specifications

---

The UHF radio operates in the 902 – 928 MHz frequency range in accordance with FCC Rules and Regulations.

The HF radio operates at 13.56 MHz in accordance with FCC Rules and Regulations.

Additional frequencies may be available for international locations by request. Contact your RFID Representative for more information.







## Free Manuals Download Website

<http://myh66.com>

<http://usermanuals.us>

<http://www.somanuals.com>

<http://www.4manuals.cc>

<http://www.manual-lib.com>

<http://www.404manual.com>

<http://www.luxmanual.com>

<http://aubethermostatmanual.com>

Golf course search by state

<http://golfingnear.com>

Email search by domain

<http://emailbydomain.com>

Auto manuals search

<http://auto.somanuals.com>

TV manuals search

<http://tv.somanuals.com>