

Operating Instructions

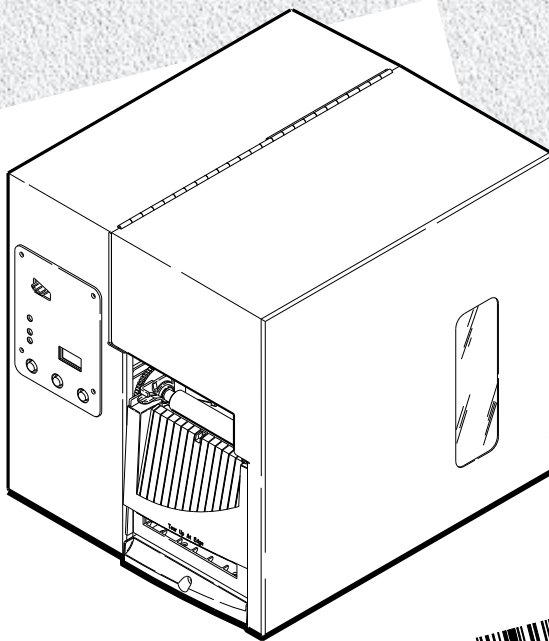

Monarch®
9805™ Printer

ONLINE TABLETOP PRINTER
THERMAL DIRECT OR
TRANSFER
ON-DEMAND OR
CONTINUOUS
PEELS LABELS
PRODUCES 4" X 6" IMAGES



Ship From:
Dayton, Ohio



Ship From:
Dayton, Ohio



Ship From:
Dayton, Ohio

Monarch®
PAXAR

Each product and program carries a respective written warranty, the only warranty on which the customer can rely. Monarch reserves the right to make changes in the product, the programs, and their availability at any time and without notice. Although Monarch has made every effort to provide complete and accurate information in this manual, Monarch shall not be liable for any omissions or inaccuracies. Any update will be incorporated in a later edition of this manual.

©1998 Monarch Marking Systems, Inc. All rights reserved. No part of this publication may be reproduced, transmitted, stored in a retrieval system, or translated into any language in any form by any means, without the prior written permission of Monarch Marking Systems, Inc.

WARNING

This equipment has been tested and found to comply with the limits for a Class A digital device, pursuant to Part 15 of the FCC Rules. These limits are designed to provide reasonable protection against harmful interference when the equipment is operated in a commercial environment. This equipment generates, uses, and can radiate radio frequency energy and, if not installed and used in accordance with the instruction manual, may cause harmful interference to radio communications. Operation of this equipment in a residential area is likely to cause harmful interference in which case the user will be required to correct the interference at his own expense.

CANADIAN D.O.C. WARNING

This digital apparatus does not exceed the Class A limits for radio noise emissions from digital apparatus set out in the Radio Interference Regulations of the Canadian Department of Communications.

Le présent appareil numérique n'émet pas de bruits radioélectriques dépassant les limites applicables aux appareils numériques de la classe A prescrites dans le Règlement sur le brouillage radioélectrique édicté par le ministère des Communications du Canada.

Trademarks

MONARCH is a registered trademark of Monarch Marking Systems, Inc.
9805 is a trademark of Monarch Marking Systems, Inc.
Paxar is a trademark of Paxar Corporation.

Monarch Marking Systems
P.O. Box 608
Dayton, Ohio 45401

Connecting the Power Cable

1. Plug the power cable into the socket. Plug the other end of the cable into a grounded electrical outlet.
2. Turn on the printer. Press (I) to turn on and (O) to turn off the printer.

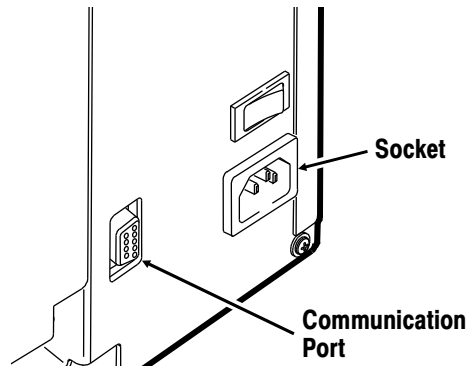

Connecting the Communication Cable

Make sure the printer is off before connecting the cable to the communication port. The printer uses a 9 pin cable. Connect the communication cable.

Establishing Communications

Before the printer can accept print jobs from the host, you must:

- ◆ Connect the communication cable to the printer and to the host.
- ◆ Set the communication values on the printer to match those at the host.

Make sure the printer's communication values match those at the host. The factory default values are: **Baud:** 9600 **Word Length:** 8 bit **Stop Bits:** 1 stop bit **Parity:** none **Flow Control:** DTR

Print a test label to check current communication settings. To change these settings, refer to the optional *Packet Reference Manual* available from our Web site or in a printed version by ordering part number TC9800PM.

Using the Control Panel

The status code box displays a three-digit error code to identify any printer problem. See "Common Errors" for more information.

Printer Status Lights

- Power:** The printer shows a steady green light when it is on.
- Supplies:** The printer shows a blinking amber light when it is out of labels or ribbon, or when you have a supply jam.
- Paused:** The printer shows a steady amber light when paused.
- The printer shows a blinking amber light when there is a data, communication, or data formatting error. See the display for the error code.

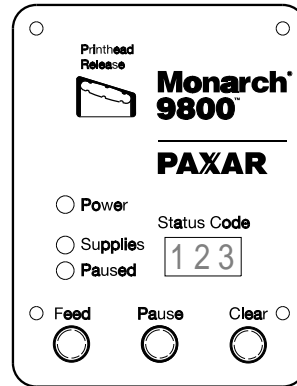

The printer also shows a blinking amber light when there is a printed label ready to be removed in on-demand mode.

Button Functions

Some functions require buttons to be pressed in sequence. Do not press buttons at the same time.

- Feed:**
- ◆ Feeds a blank label if there is no print job.
 - ◆ By passes a supply error.
- Pause:** Pauses the current print job or resumes a paused print job.
- Pause and Feed:** Allows you to print a test label or adjust print contrast from paused mode.
- Clear:**
- ◆ Clears an error.
 - ◆ Press **Clear** once to cancel the current print job.
 - ◆ Press **Clear** twice to cancel all queued print jobs.

To cancel a single or all queued print jobs, the printer must be in paused mode before **Clear** is pressed. To cancel all formats, batches, graphics, or check digits, turn off the printer.

Loading Labels

Thermal Direct Supplies that do not require a ribbon for printing.

Thermal Transfer Supplies require a ribbon for printing. Some models may not support thermal transfer printing.

If you are using thermal direct supplies, do not load a ribbon. Make sure the printer is configured for the correct supply type. If you experience supply feeding problems with 2.0-inch wide or less supplies, adjust the wide/narrow knobs to the wide setting. You may also need to use the wide setting in cold, dry environments.

1. Open the cover.
2. Unlock the printhead by turning the retaining latch.
3. Lift printhead assembly using the printhead tab until the assembly locks into place.
4. Center the roll of supply on the supply holder. Make sure the supply unrolls from the top as shown.

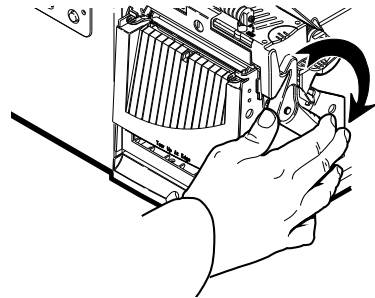

If you are using fan-fold supplies, place the supply stack behind the printer, label side facing up.

5. Push down on the supply lever to unlock the supply guides.
6. Lay the label strip across the supply guide so that a few inches extend past the front of the printer. Tuck the supply under the nibs.

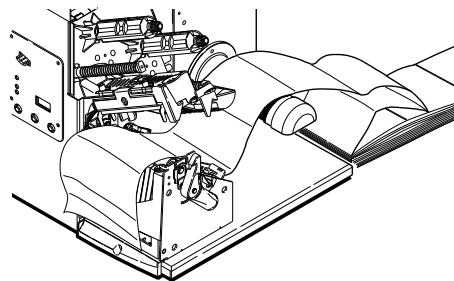
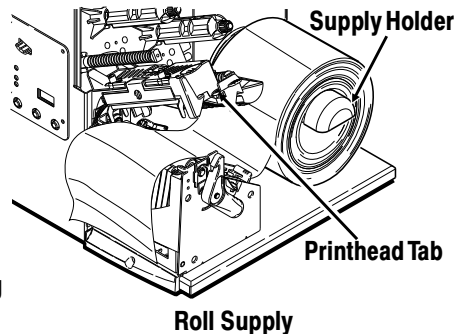

Fan-Fold Supply

For fan-fold supplies, Lay the label strip over the supply holder and across the supply guide so that a few inches extend past the front of the printer. Tuck the supply under the nibs on the supply guide.

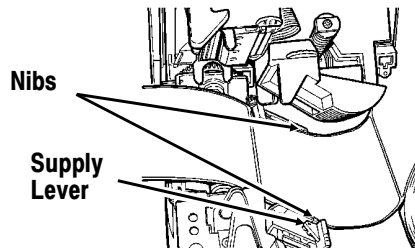

7. Adjust the supply guides so they touch the supply. Push up on the supply lever to lock the supply guides into place.

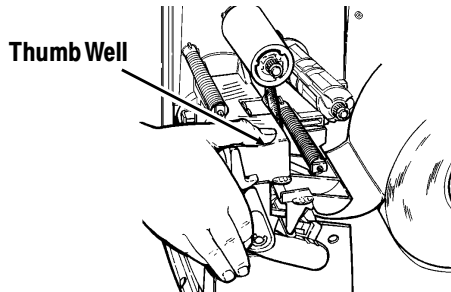

8. Hold the printhead assembly by the printhead tab while pressing down on the printhead release.
9. Close the printhead by pressing down on the thumb well until you hear it click into place.
10. Close the cover.
11. Press **Feed** to position the supply under the printhead.

You may need to adjust the wide/narrow knobs depending on the width of your supply. See "Adjusting the Wide/Narrow Knobs" for more information.

If the printer will be unused for extended periods of time, we recommend leaving the printhead unlatched.

For Peel Mode:

The minimum feed length is 1.5 inches for peel mode. You must use non-perforated supplies for peel mode. Load supplies as shown above. Follow these steps after you close the printhead.

1. Remove the labels from the first 10 inches of the backing paper.
2. Press down on the exit cover tabs to open the exit cover on the front of the printer.

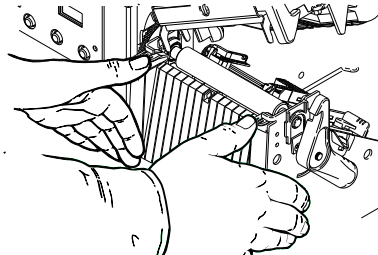

3. Feed the backing paper over the peel bar.
4. Feed the backing paper through the lower opening of the exit cover. Close the exit cover. Pull down on the backing paper to remove any slack.

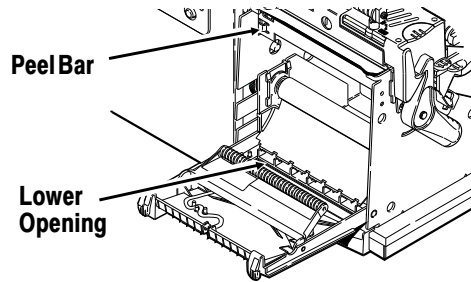

When removing the backing paper, pull up across the saw-toothed tear edge. Make sure the backing paper tears at the edge.

5. Close the printer's cover.
6. Press **Feed** to position the supply under the printhead.

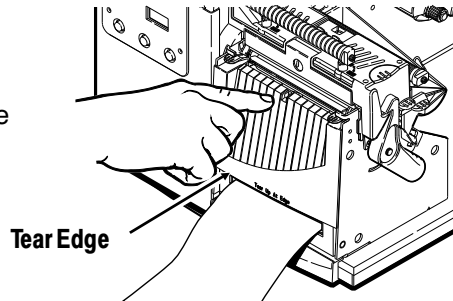

Adjusting the Wide/Narrow Knobs

You may need to adjust the two wide/narrow knobs according to the width of your supply. For supply that is more than two inches wide, adjust the knobs to the wide setting. For supply that is two inches wide or less, adjust the knobs to the narrow setting. Adjust both of the knobs to the same position.

For wide supplies, push down and turn the wide/narrow knobs clockwise with a screwdriver. For narrow supplies, turn the wide/narrow knobs counter-clockwise with a screwdriver until it pops back up. The adjustment is shown in the wide position.

If you experience supply feeding problems with 2.0-inch wide or less supplies, adjust the wide/narrow knobs to the wide setting. You may also need to use the wide setting in cold, dry environments.

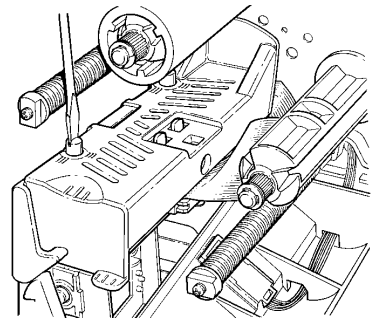

Loading Ribbon

If the ribbon reels continue to turn when you change a ribbon, press **Pause** to stop the reels from turning. You can also change the ribbon when the printer is turned off.

1. Open the cover.
2. Unlock the printhead by turning the retaining latch.
3. Lift printhead assembly using the printhead tab until the assembly locks into place.
4. Push the deflector tab down.

5. Slide the extra ribbon core on the take-up reel as far as it will go with the "Monarch This End Out" writing facing out. Use your empty ribbon core as the take-up core. The take-up core only fits on the take-up reel one way. (An extra take-up core is available by ordering part number 117961.)

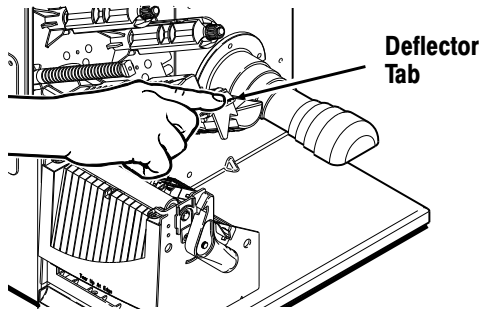

6. Remove the new ribbon from the package. Do not wrinkle or crush the new ribbon.
7. Slide the ribbon onto the back reel as far as it will go. The ribbon roll only fits on the reel one way. Carefully unwind a few inches of ribbon from the bottom of the roll.
8. Carefully feed the ribbon under both ribbon rollers and printhead.
9. Align the ribbon and make sure it is straight and centered throughout the path.

10. Tape the ribbon to the take-up core. **Do not tape the ribbon to the take-up reel.**
11. Rotate the take-up core until the leader is past the printhead and remove any slack in the ribbon by turning the take-up reel clockwise.
12. Hold the printhead assembly by the printhead tab while pressing down on the printhead release.
13. Close the printhead by pressing down on the thumb well until you hear it click into place. Close the cover.

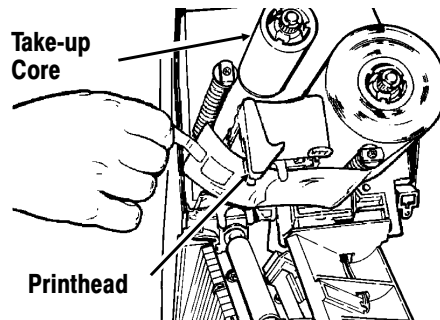

Printing

1. Turn on the printer.
2. Download a format and a batch. The printer prints a strip of labels.
3. Remove the printed labels.

If you turn off the printer, you must wait 10-15 seconds (until the power light is completely dim) before turning it back on; otherwise an error occurs.

On-Demand Mode Printing

In on-demand mode printing, the first label is printed and dispensed. The next label prints when the previous label is removed. If a label does not print, make sure the supply sensor is clean and not blocked. You must use on-demand printing with peel mode. The printer backfeeds only in on-demand mode.

Printing the Euro-Dollar Symbol

You can print the Euro-Dollar symbol (€) online by using ~192 (ASCII code) in the data stream. Your System Administrator can also select the Euro-Dollar symbol by sending the Monetary Formatting Packet (packet D). For more information, refer to the optional *Packet Reference Manual* available from our Web site or in a printed version by ordering part number TC9800PM.

Adjusting Print Contrast

You may need to adjust the print contrast if your printing is too dark or too light. Having the correct contrast is important because it affects how well your bar codes scan and how long your printhead lasts.

1. Press **Pause**.
2. Press **Feed** once. A test label prints. **After** the test label prints, press **Feed** again. You will see 000 on the display.
3. Press **Clear** to increase the print contrast or press **Feed** to decrease the print contrast.

If the contrast has a negative value, the Supplies
light is on. After you adjust the contrast, the
setting is displayed.

4. Press **Pause** to save the print contrast changes. Press **Pause** again to exit Paused mode.

Your System Administrator can adjust the print contrast by sending the print control packet. Refer to the optional *Packet Reference Manual* available from our Web site or in a printed version by ordering part number TC9800PM. We recommend you check the bar code print quality with a bar code verifier. If you do not have a bar code verifier or scanner, check the bar code visually. A bar code that is in spec has complete bars, clear spaces, and small alphanumeric characters look complete. An in spec bar code may not look as good as one that is too dark, but it has the highest scan rate.



Dark



IN SPEC



Light

Clearing Label Jams

If a jam occurs, the **Supplies** light on the printer's front panel blinks.

1. Turn off the printer. Open the cover and printhead assembly.
2. If necessary, remove the label roll and ribbon.
3. Remove the jammed labels and reload the label roll.
4. Close the printhead assembly and turn on the printer. Press **Feed** to position the supply under the printhead.

Cleaning

You may need to clean the printhead and platen roller:

- ◆ when there is any adhesive build-up in the supply path
- ◆ after printing approximately 8 rolls of supply, after using two ribbons, or whenever you load new supplies
- ◆ when you see voids in the print.

CAUTION

Do not use sharp objects to clean the printhead. This may damage the printer and void your warranty.

1. Turn off the printer.
2. Open the cover and printhead assembly.
3. Remove the label roll and ribbon (when cleaning the printhead).
4. Press down on the exit cover tabs to open the exit cover on the front of the printer.
5. Clean the platen roller with a dry cloth or small brush. However, if there is adhesive gum build-up on the platen roller, moisten a cotton swab with isopropyl alcohol. Turn the platen roller with your finger and run the

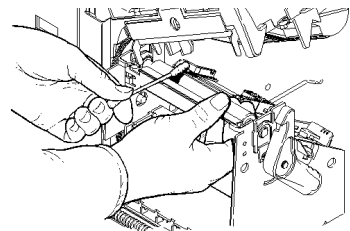

Platen Roller

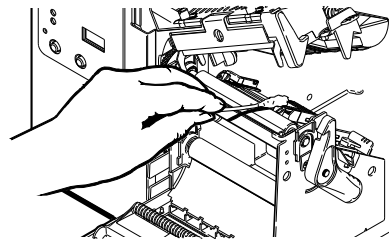

Supply Sensor

cotton swab or dry cloth across it. Make sure the platen roller is clean all the way around.

6. Rub the cotton swab across the peel bar, printhead, and supply sensor to remove any build-up.
7. Clean the build-up in the supply path.

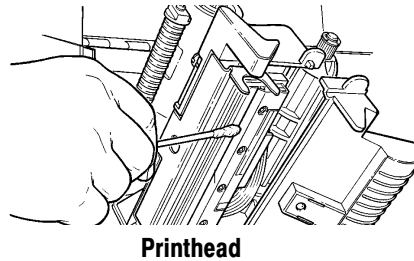

Let the printer dry before you reload supplies, close the exit cover, turn on the printer, press **Feed** to position the supply under the printhead, and resend your format/batch/graphic/check digit packets.

Replacing the Printhead

You may have to replace the printhead if it is damaged or worn-out. For example, you may see 616 (bad dot or dots) or 768 (printhead failure) error codes.

CAUTION

The printhead is sensitive to static electricity, which can damage the printhead or reduce its life. Ground yourself by touching some metal, such as the printer's metal base, before touching the printhead. Clean the printhead to remove any salt or oil left from handling prior to operation.

1. Turn off the printer.
2. Open the cover.
3. Unlock the printhead by turning the retaining latch.
4. Press forward and down on the two latches on top of the printhead assembly as shown. The printhead will drop down.

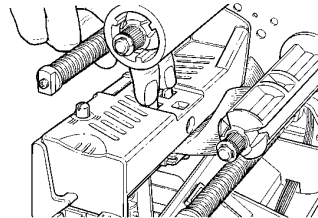

5. Lift the printhead assembly using the printhead tab and push back until the printhead assembly clicks into place.
6. Carefully unplug the cable from the printhead as shown.
7. Carefully plug the cable into the new printhead.
8. Align the new printhead with the tabs.

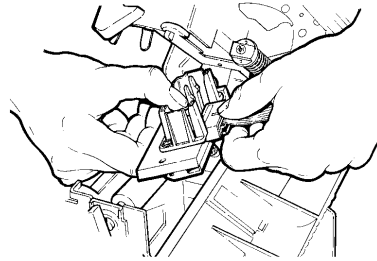

9. Snap the printhead into place. Make sure the printhead cable does not touch the ribbon roll.
10. Clean the new printhead with a cotton swab dipped in isopropyl alcohol to remove any salt or oil left from handling.

Do not touch here

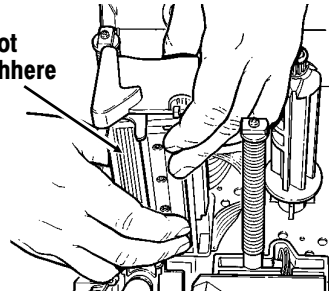

Printing a Test Label

Press **Pause** and then press **Feed**. The label shows the model number, software version, stock count, voltage, print contrast, printhead resistance, communication settings, ENQ characters, and code page selection.

If using on-demand mode, a test label prints only after all labels in the batch are printed and removed.

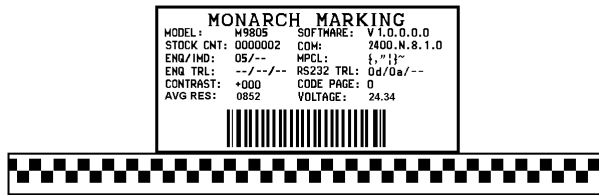

If you turn off the printer, you must wait 10-15 seconds (until the power light is completely dim) before turning it back on; otherwise, an error occurs.

Troubleshooting

Problem	Action
Error message appears during startup.	Turn off the printer, wait fifteen seconds and then turn on the printer. Call Technical Support if the error message reappears.
Does not print.	Check supply. Check ribbon. Send a corrected format and batch packet. The printer's buffers are full. Turn off the printer to clear the buffers.
Does not feed.	Set wide/narrow knobs correctly.
Partially printed data.	Clean the printhead. Send a corrected format packet.
Printing shadows or smears.	Clean the printhead. Change supply. Check ribbon.
Light printing.	Change supply. Adjust the print contrast. Check wide/narrow knobs. Check ribbon.
Dark printing.	Clean the printhead. Change supply. Adjust the print contrast. Check wide/narrow knobs. Check ribbon.
Voids in printing.	Clean the printhead. Change supply type. Check ribbon. Leave printhead unlatched when not in use.
Serial bar codes do not scan.	Check ribbon. Use a print speed of 2.5 IPS. Adjust the print contrast.
Backing paper is wrapped around platen or peel roller.	Carefully remove the backing paper. Make sure the backing paper tears at the saw-toothed tear edge when using peel mode.
Blank labels print or 750 series errors.	Clean supply sensors.

Common Errors

Error	Description
025	String length is outside the range 0 to 2710 .
101	The format referenced by batch is not in memory.
409	The printer memory is full. Delete unnecessary formats or graphics from memory.
410	Parity mismatch.
411	Framing error (baud rate mismatch).
412	Flow control mismatch.
413	Online receive queue is full. Check for a flow control problem.
611	Font, bar code, or density in the batch does not fit the format.
612	The data in this line of the batch is either missing or does not match the format.
613	Reference point off supply.
614	Portion of field off supply or there may be an invalid character in the packet.
703	The printer sensed a calibration of different-sized black marks. Make sure the correct supply is loaded. The 9805 printer does not support black mark supply.
704	Printer has not sensed a supply mark within the specified number of inches or is out of supplies. Check the supply tracking, supply marks, black mark sensor position, and supply roll for binding. Change supply. Press Clear .
750	Printhead is overheated. Turn off the printer.
751	Printer did not sense a black mark when expected. For errors 751-753, Check the supply tracking, supply marks, black mark sensor position, and supply roll for binding. Press Clear and try to continue printing. Change supply. The 9805 printer does not support black mark supply.
752	Printer sensed a mark in the wrong place. The 9805 printer does not support black mark supply.
753	Printer sensed a mark that is too long. The 9805 printer does not support black mark supply.
754	Check for a ribbon jam or remove any slack by turning the take-up reel clockwise.
755	Printhead is open. Close the printhead before continuing.
756	Load supplies.
757	Load supplies (supply length mismatch), because the calibrated supply length differs by plus or minus .25 inches from the format. Press Feed .

Error	Description
758	Either the supply is not seen or the on-demand sensor is broken. Check for a label jam, clear the supply path, or reload supplies. This error may occur if you remove a label too quickly in on-demand mode. The printer does not recalibrate after this error.
763	Waiting to dispense label. Press Feed .
765	The printhead has less than four bad dots. The printer can shift bar code fields to avoid bad dots. Press Clear to continue printing. Print a test label to confirm the number of bad dots.
768	Printhead has more than 10 bad dots or is not connected. Connect the printhead.
791	The printer has an error pending. Turn off the printer. Wait 15 seconds (until the power light is completely dim) and turn it back on. Resend the packets.

Check with your System Administrator for any message not listed.

Printer Specifications

Height:	13 inches (330 mm)
Width:	12 inches (305 mm)
Depth:	13 inches (330 mm)
Weight:	26 lb. (12 kg)
Shipping Weight:	30 lb. (13.6 kg)
Printhead:	Thermal at 4 inches (102 mm) wide 203 dpi (8.0 dots per mm)
Printing Method:	Thermal Transfer (ribbon) or Thermal Direct
Maximum Image Size:	4.0 inches (102 mm) by 6.0 inches (152 mm)
Power:	115 VAC, 60Hz, 100 VAC, 50/60 Hz, 230 VAC, 50 Hz (Switching power supply)
Operating Limits:	For Thermal Transfer (ribbon) 40° to 95° F (4° to 35° C)

For Thermal Direct 40° to 104° F
(4° to 40° C)

Print Speed: 2.5 ips (64 mm) for all serial bar codes and 4.0 ips (102 mm). 6.0 ips (152 mm) is available only for thermal transfer printing.

Supply Specifications

For high temperature or high humidity environments, contact Monarch for supply recommendations. Continuous supply does not have perforations or black marks and must be used in continuous mode.

Supply Types: Thermal Transfer, Direct Die Cut, or Continuous without black marks

Supply Widths: 1.2 inches (31 mm) minimum
4.25 inches (108 mm) maximum

Supply Lengths: 1.0 inch (31 mm) minimum
6.5 inches (165 mm) maximum

Supply Roll Length: 2,952 inches (75 meters)

Ribbon Specifications

Do not leave ribbon in sunlight, high temperatures or humidity.

Ribbon Type: Standard

Ribbon Widths: 1.3 inches (33 mm)
1.6 inches (41 mm)
2.16 inches (55 mm)
3.15 inches (80 mm)
4.13 inches (105 mm)

Ribbon Length: 23,600 inches (600 meters)

About Ribbons

The width of the ribbon must be greater than the supply width. Since some supplies are more abrasive to printheads than others, using a ribbon wider than your supply helps protect the printhead. Replacement printheads are expensive.

DECLARATION OF CONFORMITY

according to ISO/IEC Guide 22 and EN 45014

Manufacturer's Name : Monarch Marking Systems, Inc.

Manufacturer's Address : 170 Monarch Lane, at 175 and SR725
Miamisburg, Ohio 45342
U.S.A.

Declares that the product :

Product Name : Table Top Thermal Printer

Model Number : 9805, M09805

Conforms to the following Product Specifications :

Safety : EN60950 AM1, AM2

EMC : C.I.S.P.R. 22, EN 55022 Class A and Class B
FCC Part 15, Subpart B, Class A and Class B

EMI : EN 50082-1 Generic Immunity Standard
IEC 801-2 ESD
IEC 801-3 Radiated Electromagnetic
IEC 801-4 Electrical Fast Transient / Burst
EN 60555-2 Line Harmonics

Ergonomics : NA

According to :

- EMC directive - 89/336/EEC
- Low Voltage directive - 73/23/EEC

Miamisburg, Ohio

January 25, 1999

Download from www.Somanuals.com All Manuals Search And Download.

Location

Date

Signature

For supplies, service, or assistance call toll free:

1-800-543-6650 (In the U.S.A.)

1-800-263-4650 (In Canada)

www.monarch.com

Free Manuals Download Website

<http://myh66.com>

<http://usermanuals.us>

<http://www.somanuals.com>

<http://www.4manuals.cc>

<http://www.manual-lib.com>

<http://www.404manual.com>

<http://www.luxmanual.com>

<http://aubethermostatmanual.com>

Golf course search by state

<http://golfingnear.com>

Email search by domain

<http://emailbydomain.com>

Auto manuals search

<http://auto.somanuals.com>

TV manuals search

<http://tv.somanuals.com>