



Quick Reference

Switching Between Print Modes—Peel Mode or Non-peel Mode

1. Press the Pizza Hut® button on your keypad/terminal.
2. Press the Cheese button to display “NON-PEEL MODE” or “PEEL MODE” until the print mode you want is displayed.
3. Press the Pizza Hut® button to save your choice.
4. The printer LED will blink red. Press the printer FEED button. The printer LED will turn green, indicating the printer is ready. Default mode is non-peel.

Loading Labels for Hot-Hold (Peel) Labeling

Follow these instructions to print and peel labels from the backing paper one at a time.

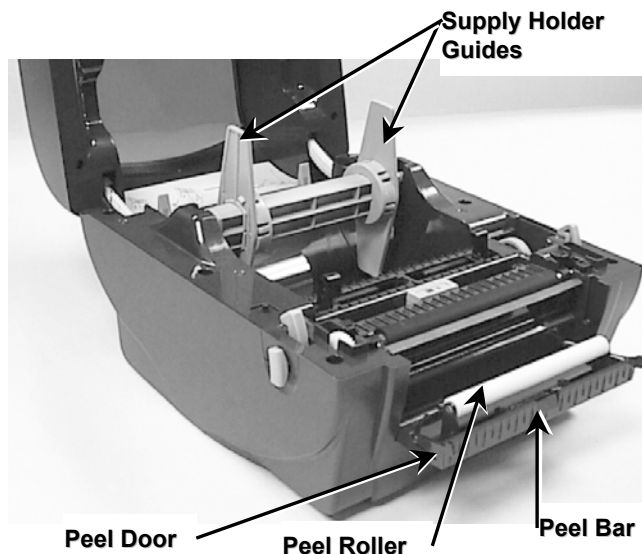

1. Press the cover release levers towards you to release the cover and then lift it open.
2. Pull out the peel door located on the front of the printer to display the peel roller and the peel bar.
3. Remove a supply holder guide from one end of the supply holder.
4. Slide a roll of labels onto the supply holder.
5. Place the supply holder guide back onto the end of the supply holder.

Push the label core adapters into the ends of the supply and center the labels on the supply holder. The number 4 (on the supply holder) should be visible on either side of the supply holder guides.

6. Place the loaded supply holder in the slots in the label roll mount. **Push the plastic line attached to the end of the supply holder out of the way.**
7. Remove the first two labels from the backing paper.
8. Feed the labels, printing side up, under the supply guides and over the platen roller.
9. Feed the backing paper under the peel roller and through the peel door opening.

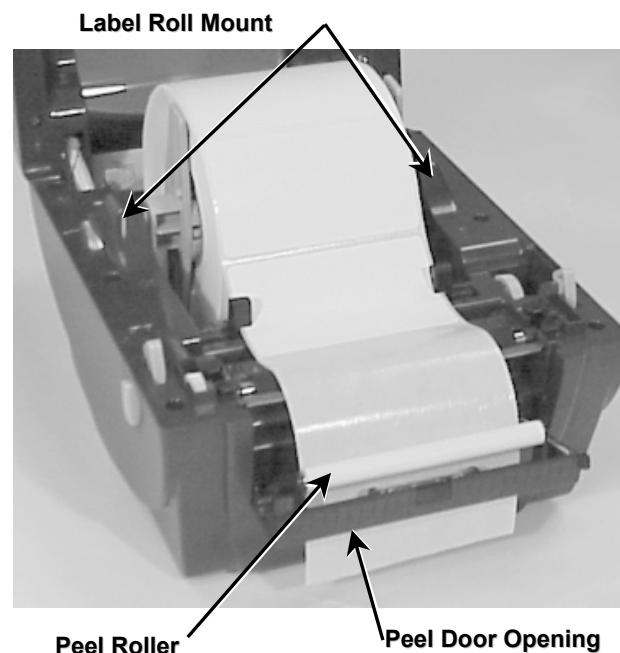

10. Push the peel door closed and close the cover until it locks in place.
11. Press the FEED button. A label will peel off of the backing paper.
12. Remove the peeled label and another one prints.

Loading Labels for Dough and MRD (Non-Peel) Labels

Follow these instructions to print multiple labels on a continuous strip.

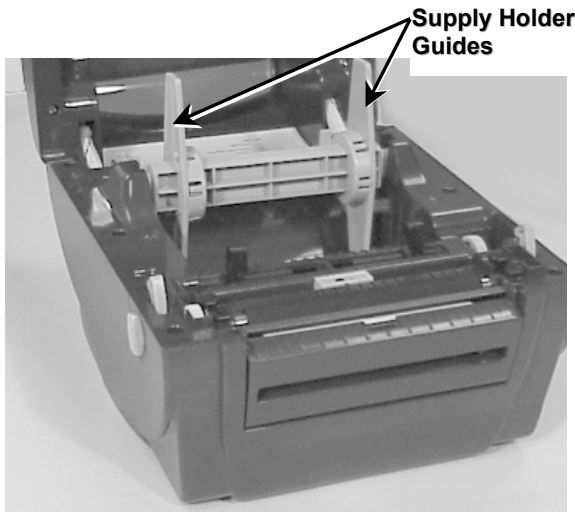

1. Press the cover release levers towards the front of the printer to release the cover, then lift it open.
2. Remove the supply holder guide from one end of the supply holder.
3. Slide a roll of labels onto the supply holder.
4. Place the supply holder guide back onto the end of the supply holder. **Push the label core adapters into the ends of the supply and center the labels on the supply holder. The number 4 (on the supply holder) should be visible on either side of the supply holder guides.**

5. Insert the ends of the supply holder into the slots in the label roll mount. **Push the plastic line attached to the end of the supply holder out of the way.**
6. Feed the labels, printing side up, under the supply guides and over the platen roller.
7. Turn the dial to move the supply guides so they barely touch the edges of the backing paper.
8. Close the cover until it locks in place.

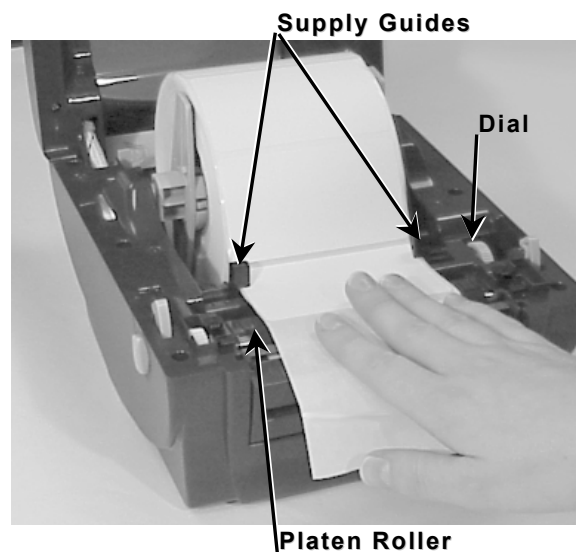

9. Press the FEED button. The indicator light should be GREEN.

IF YOU NEED HELP, CALL 1-888-666-9414. IF YOU NEED MORE PAPER LABELS, CALL ONE OF THE FOLLOWING:

PrimeSource: 800-397-4737 (order item #85221)

Wasserstrom: 800-999-9277 (order item #374014)

Unified Food Co-Op: 800-444-4144 (order item #374014)

Free Manuals Download Website

<http://myh66.com>

<http://usermanuals.us>

<http://www.somanuals.com>

<http://www.4manuals.cc>

<http://www.manual-lib.com>

<http://www.404manual.com>

<http://www.luxmanual.com>

<http://aubethermostatmanual.com>

Golf course search by state

<http://golfingnear.com>

Email search by domain

<http://emailbydomain.com>

Auto manuals search

<http://auto.somanuals.com>

TV manuals search

<http://tv.somanuals.com>