

KB/A™ 100

KEYBOARD / ACOUSTIC
AMPLIFIER

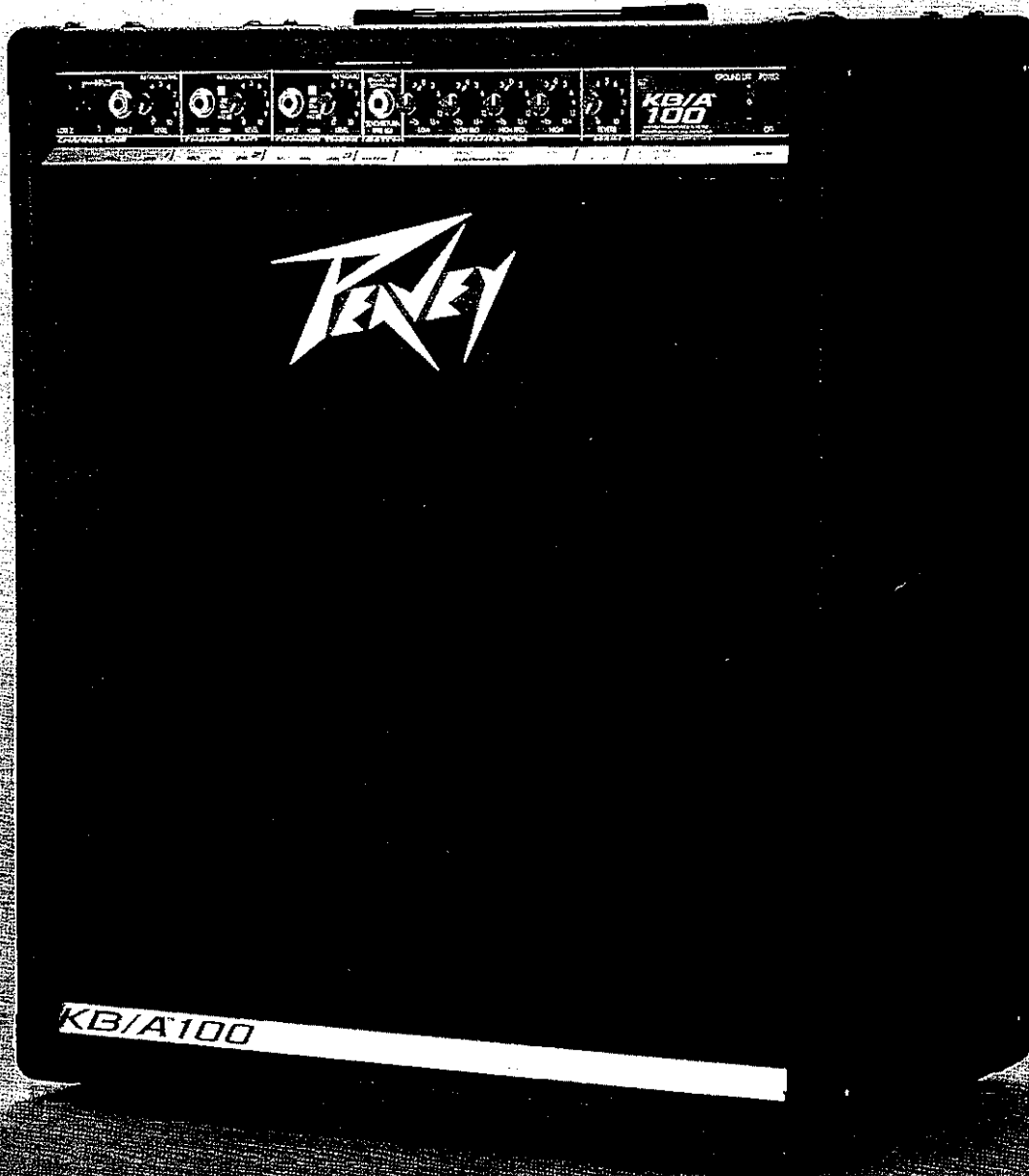

OPERATING GUIDE



ENGLISH

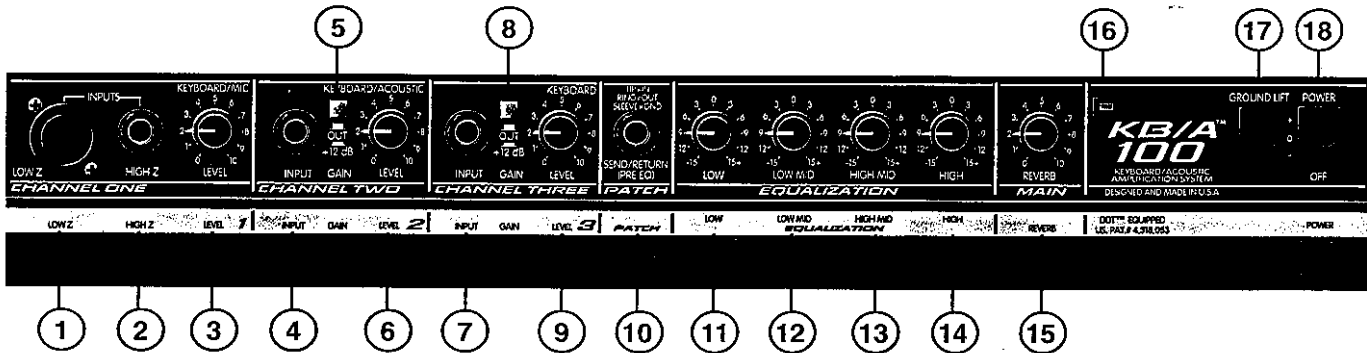

Thank you for selecting the KB/A™ 100 keyboard/acoustic amplification system! Once again, Peavey engineers have listened to input from keyboard players and put together a system that combines excellent features and sound in a portable, stylish package. The new KB/A™ series amplifiers also deliver awesome sound for drum machines and acoustic instruments. From thundering bass to crystal highs, it's all there. For the full scoop, check out the features below.

FRONT PANEL FEATURES

CHANNEL ONE:

LOW-Z INPUT (1)

For use with low-impedance microphones or low-level sources equipped with a male XLR connector.

HIGH-Z INPUT (2)

For use with high-impedance microphones or high-level sources equipped with a 1/4" phone plug.

MIC LEVEL (3)

Controls the microphone's input level.

CHANNEL TWO:

HIGH-Z INPUT (4)

A 1/4" phone jack input is provided with extremely "wide" dynamic range. This input will accept very high-level signals generated by synthesized keyboard systems or very low signals generated by practice or home keyboard units. This input is also for acoustic guitars and can be muted with a footswitch (optional).

GAIN SWITCH (5)

Boosts the gain of its channel by 12 dB. Depress to the "in" position to activate.

LEVEL (6)

Controls the Channel Two 1/4" phone jack input level.

CHANNEL THREE:

HIGH-Z INPUT (7)

A 1/4" phone jack input is provided with extremely "wide" dynamic range. This input will accept very high-level signals generated by synthesized keyboard systems or very low signals generated by practice or home keyboard units.

GAIN SWITCH (8)

Boosts the gain of its channel by 12 dB. Depress to the "in" position to activate.

LEVEL (9)

Controls the Channel Three 1/4" phone jack input level.

PRE EQ PATCH:

SEND/RETURN JACK (10)

A stereo out/in jack allows the uses of various auxiliary units (chorus, flanging, tape/digital/analog delays, equalizers, etc.) in line before the Equalization section. To utilize this system, a stereo plug (tip/ring/sleeve) to a "Y" cord must be used. The tip portion of the 1/4" stereo jack serves as the signal send (output), while the ring portion will return the processed signal to the system. The sleeve portion serves as the ground. The Pre EQ patch affects all three channels.

Since this is a stereo jack configuration, the first click on the jack may be used as a Pre EQ output with a mono 1/4" plug if desired. This first click will not disturb the signal flow to the remainder of the system as it is fed into the EQ section.

Note: IF THE SECOND CLICK OF THE OUT/IN JACK IS UTILIZED WITHOUT RETURNING ANY SIGNAL TO THE SYSTEM FROM AN EFFECTS DEVICE, THE REMAINING PREAMP FUNCTIONS WILL BE DISABLED.

EQUALIZATION:

LOW EQ (11)

An active tone control (Shelving type, ± 15 dB) that varies the low frequency range.

Caution: Excessive low frequency boost causes greater power consumption and increases possibility of speaker damage.

LOW/MID EQ (12)

An active tone control (Peak/notch, ± 12 dB) that varies the low/mid frequency range.

HIGH/MID EQ (13)

An active tone control (Peak/notch, ± 12 dB) that varies the high/mid frequency range.

HIGH EQ (14)

An active tone control (Shelving type, ± 15 dB) that varies the high frequency range.

MASTER:

MAIN REVERB (15)

The Main Reverb control determines the desired amount of reverberation from the internal reverb system. Clockwise rotation increases the reverb effect and counterclockwise decreases the effect.

POWER LED (16)

Illuminates red when AC power is being supplied to the amp.

GROUND SWITCH (17)

Three-position, rocker-type switch which, in most applications, should be operated in its center or zero position. There may be some situations when audible hum and/or noise will come from the loudspeaker. If this situation arises, position the ground switch to either positive or negative (+ or -), or until the noise is minimized.

Note: Should the noise problem continue, consult your Authorized Peavey Dealer, the Peavey factory, or a qualified service technician. THE GROUND SWITCH IS NOT FUNCTIONAL ON 220/240 VOLT MODELS.

POWER SWITCH (18)

Depress the switch to the "on" position. The red LED will illuminate indicating power is being supplied to the unit.

Back Panel:



BACK PANEL FEATURES

LINE CORD — 120 V products only (19)



For your safety, we have incorporated a 3-wire line (mains) cable with proper grounding facilities. It is not advisable to remove the ground pin under any circumstances. If it is necessary to use the equipment without proper grounding facilities, suitable grounding adapters should be used. Less noise and greatly reduced shock hazard exists when the unit is operated with the proper grounded receptacles.

HEADPHONE JACK (20)

A stereo jack is provided in order to allow the signal to flow to each side of any stereo headset. When a stereo headset is plugged in, the internal speaker is automatically turned off so that a totally private rehearsal situation can be accomplished.

Note: The headphone system will not work with headsets that have a mono phone plug.

PREAMP OUT/POWER AMP IN JACKS (21)

These jacks are provided for in-line patching of effects devices. To patch an effects unit, connect the Preamp Output to the input of the device. Next, connect the output of the device to the Power Amp Input (high-quality shielded cables must be used for these connections). The Preamp Output can also be used to route the amplified signal to a mixing console, tape recorder, etc. Connect the Preamp Output, using a shielded cable, to an input of the tape recorder, mixer, etc. This patch does not affect the operation of the amplifier.

Note: The preamp output level is approximately 1 volt RMS and is of relatively low impedance (600 ohms). Any effects device used in this effects loop must be capable of receiving 1 volt input and providing 1 volt output in order to properly drive the power amp. The Power Amp Input has an internal switch which disconnects the internal preamp.

REVERB SWITCH JACK (22)

For connection of a footswitch (optional) and is used to activate/defeat reverb.

CHANNEL TWO MUTE (23)

For connection of a footswitch (optional) and is used to activate/defeat the mute on Channel Two.

SPECIFICATIONS

PREAMP SECTION

The following preamp specs are measured at 1 kHz with the master EQ set flat at 0 dB, all gain switches in the out position, the main reverb at 0, nominal signal levels are with channel level controls set at 5, minimum level are with channel level controls set at 10.

Channel One Inputs:

Low-Z Input Impedance: 3.3 K ohms
Nominal Input Level: -30 dBV, 32 mV RMS
Minimum Input Level: -40 dBV, 10 mV RMS
High-Z Input impedance: 100 K ohms
Nominal Input Level: -10 dBV, 316 mV RMS
Minimum Input Level: -20 dBV, 100 mV RMS

Channel Two & Channel Three Input:

Input Impedance: 220 K ohms
Nominal Input Level: -14 dBV, 200 mV RMS
Minimum Input Level: -36 dBV, 16 mV RMS

Channel Two Mute:

Greater Than -50 dB

Pre EQ Patch: (stereo jack tip)

Function: Low-level effects send
Load Impedance: 10 K ohms or greater
Nominal Output: -10 dBV, 316 mV RMS

Pre EQ Patch: (stereo jack ring)

Function: Low-level effects return
Impedance: High-Z, 100 K ohms
Input Level: -10 dBV, 316 mV RMS

(Switching stereo jack providing patch output to patch input connection when not used)

Preamp Output:

Function: High-level post EQ signal send
Load Impedance: 1 K ohm or greater
Nominal Output: 3 dBV, 1.4 V RMS
Maximum Output: 18 dBV, 8 V RMS

Power Amp Input:

Function: High-level post EQ signal return
Impedance: High-Z, 22 K ohms
Nominal Input: 0 dBV, 1V RMS

(Switching jack providing preamp output to power amp input connection when not used)

Headphone Output: (stereo jack)

Load Impedance: 4 ohms or greater
Nominal Output: 100 mW

(Switching jack which will disconnect internal speaker when headphone plug is inserted)

Reverb Switch: (1/4" phone jack)

Function: Reverb defeat foot switch

Channel Two Mute:

Function: Channel two mute foot switch
Greater than -50 dB

The following specs are measured at nominal setting, all phone jack inputs terminated with 47 k ohms.

Frequency Response:

(Channel input/preamp output at 1V RMS level)
+0, -3 dB, 60 Hz to 20 kHz

System Distortion:

(Channel in/preamp out, 60 Hz to 20 kHz at 1V RMS)
Less than 0.05% THD, typically below 0.01%

Preamp Hum and Noise:

-85 dBV

Channel Equalization:

± 15 dB at 80 Hz and 10 kHz, shelving
± 12 dB at 400 Hz and 2 kHz, peak/notch

POWER AMPLIFIER SECTION

Rated Power and Load:

64 W RMS into 8 ohms with DDT compression

Power at Clipping: (typically)

(1 kHz, 120 V AC line)
65 W RMS into 8 ohms at 1% THD
70 W RMS into 8 ohms at 5% THD

Frequency Response:

+0,-1 dB, 20 Hz to 20 kHz, at 50 W RMS into 8 ohms

Total Harmonic Distortion:

Less than 0.2 %, 50 mW to 50 W RMS, 20 Hz to 10 kHz,
8 ohms, typically below 0.1%

DDT Dynamic Range:

Greater than 20 dB

DDT Maximum THD:

Below 0.5% THD for 6 dB overload
Below 1% THD for 20 dB overload

Hum & Noise:

Greater than 90 dB below rated power

Power Consumption:

200 W at 120 V AC, 50/60 Hz, Domestic
200 W at 220-230/240 V AC, 60 Hz, Export

Dimensions & Weight:

25.25" H x 21" W x 12.125" D
57.10 lbs.



*Due to our efforts for constant improvements,
features and specifications listed herein are subject to change without notice.*

Flowchart

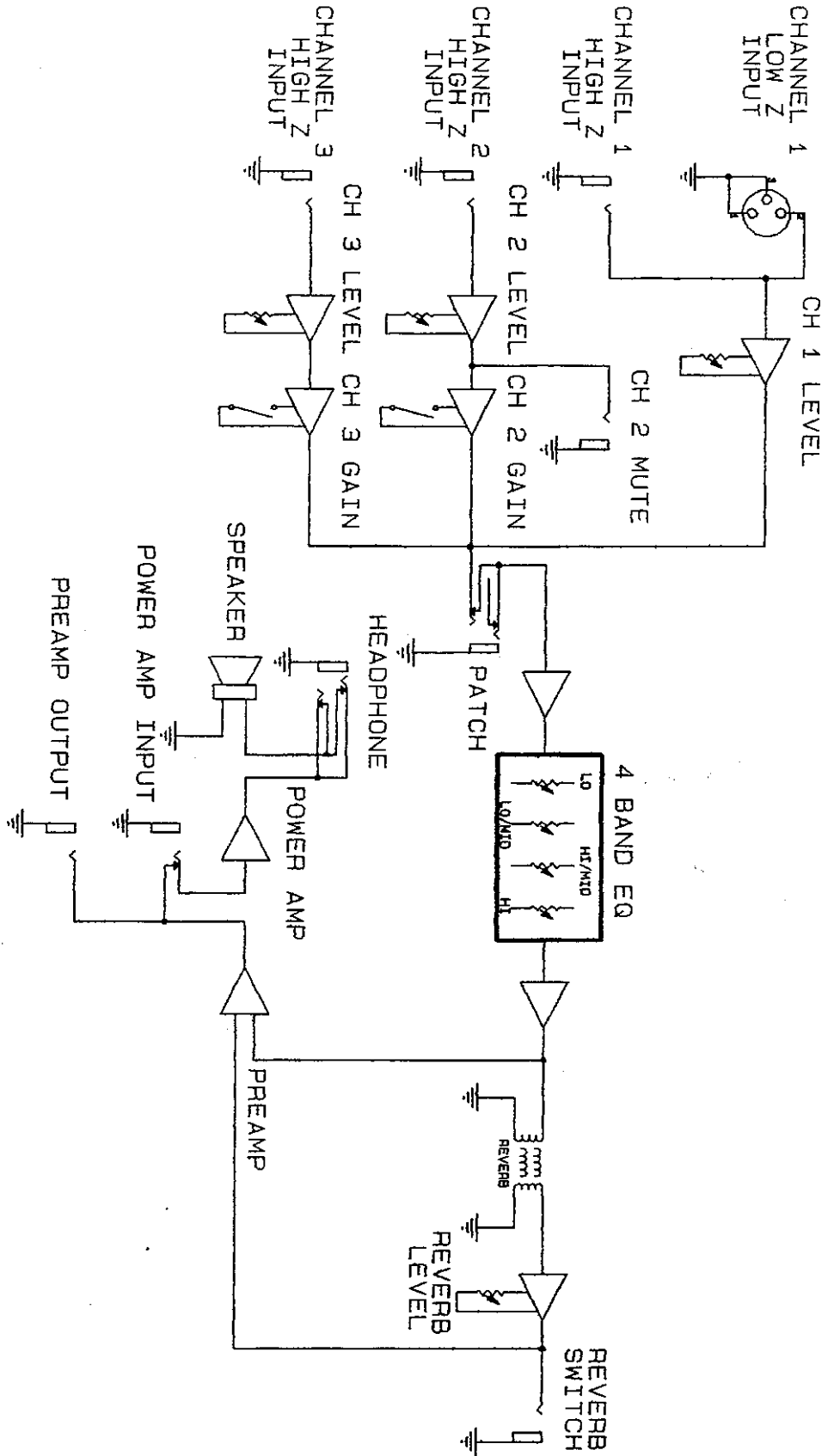

This flowchart illustrates signal flow within the unit. In order to thoroughly understand the unit's functions, please study this diagram carefully.

Free Manuals Download Website

<http://myh66.com>

<http://usermanuals.us>

<http://www.somanuals.com>

<http://www.4manuals.cc>

<http://www.manual-lib.com>

<http://www.404manual.com>

<http://www.luxmanual.com>

<http://aubethermostatmanual.com>

Golf course search by state

<http://golfingnear.com>

Email search by domain

<http://emailbydomain.com>

Auto manuals search

<http://auto.somanuals.com>

TV manuals search

<http://tv.somanuals.com>