

CS[®] 800X

PROFESSIONAL STEREO POWER AMPLIFIER

OPERATING GUIDE





Intended to alert the user to the presence of uninsulated "dangerous voltage" within the product's enclosure that may be of sufficient magnitude to constitute a risk of electric shock to persons.



Intended to alert the user of the presence of important operating and maintenance (servicing) instructions in the literature accompanying the product.

CAUTION: Risk of electrical shock – DO NOT OPEN!

CAUTION: To reduce the risk of electric shock, do not remove cover. No user serviceable parts inside. Refer servicing to qualified service personnel.

WARNING: To prevent electrical shock or fire hazard, do not expose this appliance to rain or moisture. Before using this appliance, read the operating guide for further warnings.



Este símbolo tiene el propósito de alertar al usuario de la presencia de "(voltaje) peligroso" que no tiene aislamiento dentro de la caja del producto que puede tener una magnitud suficiente como para constituir riesgo de corrientazo.



Este símbolo tiene el propósito de alertar al usuario de la presencia de instrucciones importantes sobre la operación y mantenimiento en la literatura que viene con el producto.

PRECAUCION: Riesgo de corrientazo – No abra.

PRECAUCION: Para disminuir el riesgo de corrientazo, no abra la cubierta. No hay piezas adentro que el usuario pueda reparar. Deje todo mantenimiento a los técnicos calificados.

ADVERTENCIA: Para evitar corrientazos o peligro de incendio, no deje expuesto a la lluvia o humedad este aparato. Antes de usar este aparato, lea más advertencias en la guía de operación.



Ce symbole est utilisé pour indiquer à l'utilisateur la présence à l'intérieur de ce produit de tension non-isolée dangereuse pouvant être d'intensité suffisante pour constituer un risque de choc électrique.



Ce symbole est utilisé pour indiquer à l'utilisateur qu'il ou qu'elle trouvera d'importantes instructions sur l'utilisation et l'entretien (service) de l'appareil dans la littérature accompagnant le produit.

ATTENTION: Risques de choc électrique – NE PAS OUVRIR!

ATTENTION: Afin de réduire le risque de choc électrique, ne pas enlever le couvercle. Il ne se trouve à l'intérieur aucune pièce pouvant être réparée par l'utilisateur. Confier l'entretien à un personnel qualifié.

AVERTISSEMENT: Afin de prévenir les risques de décharge électrique ou de feu, n'exposez pas cet appareil à la pluie ou à l'humidité. Avant d'utiliser cet appareil, lisez les avertissements supplémentaires situés dans le guide.



Dieses Symbol soll den Anwender vor unisolierten gefährlichen Spannungen innerhalb des Gehäuses warnen, die von Ausreichender Stärke sind, um einen elektrischen Schlag verursachen zu können.



Dieses Symbol soll den Benutzer auf wichtige Instruktionen in der Bedienungsanleitung aufmerksam machen, die Handhabung und Wartung des Produkts betreffen.

VORSICHT: Risiko – Elektrischer Schlag! Nicht öffnen!

VORSICHT: Um das Risiko eines elektrischen Schlages zu vermeiden, nicht die Abdeckung entfernen. Es befinden sich keine Teile darin, die vom Anwender repariert werden könnten. Reparaturen nur von qualifiziertem Fachpersonal durchführen lassen.

ACHTUNG: Um einen elektrischen Schlag oder Feuergefahr zu vermeiden, sollte dieses Gerät nicht dem Regen oder Feuchtigkeit ausgesetzt werden. Vor Inbetriebnahme unbedingt die Bedienungsanleitung lesen.

The world famous CS® 800 power amplifier has now been changed to the new CS® 800X with new eXtended performance, providing impressive new two ohm output power capability while still maintaining the current 4 and 8 ohm ratings and awesome industry standards for power bandwidth, slew rate, and distortion specifications.

Following is the new eXtended specs:

420 W RMS into 4 ohms...600 W RMS into 2 ohms (per channel)
840 W RMS into 8 ohms...1200 W RMS into 4 ohms (bridged)
DDT™ compression with LED indicators and defeat switch
Slew Rate: 40 V/microsecond, stereo mode, each channel
Power Bandwidth: 10 Hz to 50 KHz @ 4 ohms, rated power
Total Harmonic Distortion: Less than 0.03%, rated power
Hum and Noise: 100 dB below rated power, unweighted

All the current features of the old units have been retained, including Peavey's patented DDT™ (Distortion Detection Technique) Compression Circuitry, and the very flexible back panel patching capabilities. The two speed fan cooling system has been improved to provide additional cooling, when needed, for the two ohm load conditions.

FEATURES

- **Automatic two-speed fan cooling system/tunnel**
- **Independent channel thermal/fault protection**
- **Transient free turn-on/off operation (relay)**
- **One recessed crossover “island” socket for plug-in modules**
- **Two recessed balanced input transformer sockets for PL-2's**
- **Single XLR & dual phone plug inputs each channel**
- **Phone plug inputs are QUASI-ELECTRONIC BALANCED**
- **XLR input can be QUASI-ELECTRONIC BALANCED (push switch out)**
- **XLR input can be transformer balanced (push switch in)**
- **Dual phone plug and 5 way binding post outputs each channel**
- **DDT activation LED & power LED each channel**
- **Calibrated/detented input attenuator control each channel**
- **Rear panel DDT defeat & bridge mode select slide switches**



WARNING!

For optimum performance and reliability DO NOT PRESENT THE AMPLIFIER WITH A SPEAKER LOAD OF LESS THAN 2 OHMS, OR A COMBINATION OF SPEAKERS THAT TOGETHER ARE LESS THAN 2 OHMS!

Using one speaker, it must be rated at 2 ohms minimum.

Using two speaker, they must be rated each at 4 ohms minimum.

Using three speaker, they must be rated each at 8 ohms minimum.

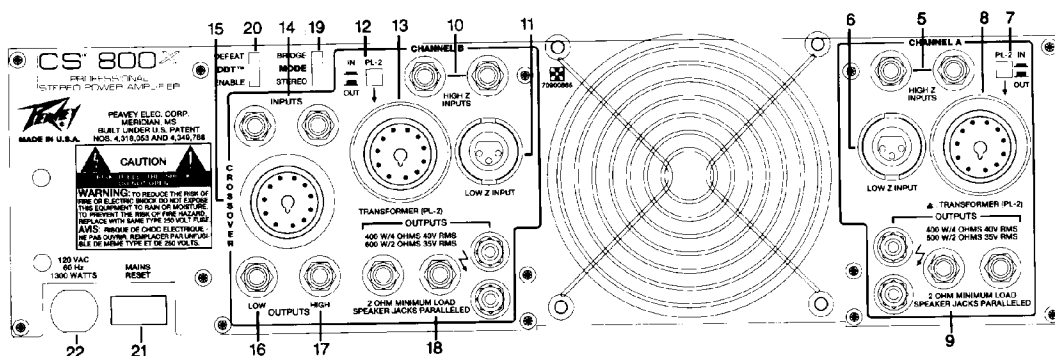
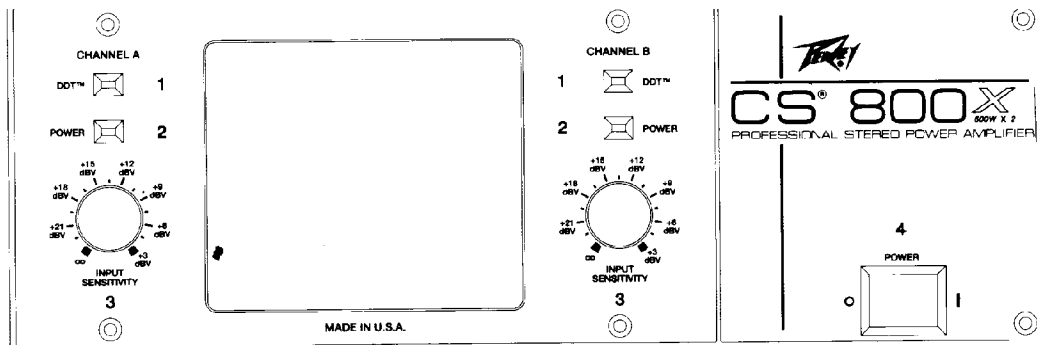

DDT™ ACTIVE LED (1)

Illuminates when DDT Compression is taking place. With the ENABLE/DEFEAT switch in the DEFEAT position, the LED indicates when clipping distortion is occurring.

POWER LED (2)

Illuminates when AC power is being supplied to the amp, and the associated channel is operational. Illumination is delayed slightly during the power-up cycle due to the transient suppression/thermal fault circuitry. If either channel were to experience fault conditions or to exceed the safe operating temperature limits, then that channel will shut down, and the associated power LED will go out, indicating such conditions exist. Also, whenever the BRIDGE mode is selected, the power LED on channel B is defeated (OFF), just as if there were a fault condition on channel B. This provides a positive indication that the CS-800X is in bridge mode.

INPUT SENSITIVITY (3)

Maximum input gain (minimum sensitivity rating) is achieved at the full clockwise setting. This setting yields maximum mixer/system headroom. A setting of less than one full clockwise turn will yield lower system noise at the expense of mixer/system headroom. Calibration indicates sensitivity in dBV necessary to attain the full available output power rating.

POWER SWITCH (4)

Depress to "On" position to turn on.

CHANNEL A

HIGH Z INPUT JACKS (5)

Two parallel (bridged) input jacks are provided. This allows for one to be used as a conventional input, and the other to be used simultaneously as a "line out" to connect to another input jack on this amplifier or other amps/equipment. These 1/4" jacks are not "chassis grounded" and when used will provide a QUASI-BALANCED input capability due to a unique "ground loop" elimination circuitry associated with the input. This feature will normally allow "hum free" operation when relatively short 1/4" cable patches are made between the various jacks on this amp and other jacks on equipment that share the same rack with this amp. This QUASI-BALANCED capability is automatic, and it can not be removed from the system's circuitry.

LOW Z INPUT (6)

A conventional three-pin female XLR input jack is provided and may be used as the channel A input. When the (PL-2) line balancing transformer is not used, this XLR input becomes QUASI-BALANCED with pin #3 as the positive input (connecting to the tip of the 1/4" input jacks above), pin #2 as the negative input (connecting to the floating sleeve of the 1/4" input jacks above), and pin #1 going to chassis ground. When the (PL-2) line-balancing transformer is used, this XLR input becomes fully TRANSFORMER-BALANCED (Pin #3 positive, pin #2 negative, pin #1 ground). (See the PL-2 SELECTOR SWITCH section for details on related settings)

PL-2 SELECTOR SWITCH (7)

This switch is to be used in conjunction with the PL-2 transformer to allow the LOW Z INPUT to function with or without a PL-2 module being inserted in the receptacle. A similar function was performed by using a PL-1 module inserted in the PL-2 receptacle on older amplifier models. The "OUT" position of this switch selects the QUASI-BALANCED mode of operation for the LOW Z INPUT (XLR jack), and routes the input signal directly to the HI Z INPUT JACKS. In this position the HI Z INPUT JACKS may be used as outputs after the LOW Z INPUT to allow patching this signal to another input on this amp. Normally, in this switch position, a (PL-2) transformer is not present ("OUT") in the transformer receptacle; however, if one were "IN" the receptacle, the LOW Z INPUT would still be QUASI-BALANCED. It becomes TRANSFORMER BALANCED only when the IN switch position is selected. Notice this is a very effective means to "test" for the necessity of a line-balancing transformer. The "IN" position of the switch routes the input signals from the XLR jack, through the (PL-2) line-balancing transformer, thus selecting the TRANSFORMER BALANCED mode of operation for the LOW Z INPUT. In this position the HI Z INPUT JACKS may be used as outputs after the line balancing transformer to patch the signal to another input jack on this amplifier or other amps/equipment. If the "IN" position is selected without a (PL-2) line-balancing transformer "IN" the receptacle, the LOW Z INPUT will be rendered inoperable.

TRANSFORMER RECEPTACLE (8)

This receptacle only receives the optional (PL-2) line-balancing transformer. When conditions exist that demand the usage of a TRANSFORMER-BALANCED XLR CONNECTOR at the

tions exist that demand the usage of a TRANSFORMER-BALANCED XLR CONNECTOR at the input of channel "A", the (PL-2) transformer must be put here, the selector switch must be in the "IN" position.



SPEAKER OUTPUTS (9)

Two 1/4" jacks and 5 way binding post speaker output terminals are provided. All these outputs are in parallel, hence the speaker connection cables can be terminated with 1/4" phone plugs, banana plugs, or stripped wires for use in the binding post terminals. For sustained high power applications, the use of the binding post terminals are recommended; however, care must be exercised to assure correct speaker phasing. Regardless of what connections are used, the typical parallel speaker load should always be limited to 2 ohms per channel or 4 ohms BRIDGE mode for any application. Operation at loads of 4 ohms per channel or 8 ohms BRIDGE mode is more desirable for sustained operation applications due to the fact that the amplifier will run much cooler at this load. Operation above 4 ohms per channel, and even open circuit conditions, can always be considered safe; however, sustained operation at loads below 2 ohms could result in temporary amplifier shut down due to the thermal limits and/or the internal fault circuitry. When used in BRIDGE mode the positive speaker lead should be connected to Channel A RED BINDING POST and the negative speaker lead to Channel B RED BINDING POST.

CHANNEL B

NOTE: On this channel a crossover module "ISLAND" has been provided to allow a PL-MODULE ELECTRONIC CROSSOVER to be used to perform a "BIAMP" function. Associated with this island are dual crossover input jacks, high and low output jacks, and a crossover receptacle. These will be discussed further in following sections, but please note that the channel B patches are somewhat different from those of channel A.

HIGH Z INPUT JACKS (10)

Two parallel input jacks are also provided in this channel, allowing the flexibility of the Y-cord capability here as well. These jacks are also not chassis grounded and will provide a QUASI-BALANCED input capability. Both of these input jacks are "switching" type, where usage of either of these jacks disables the signal feed from the LOW Z INPUT circuitry associated with this channel. This is necessary to allow this input to be patched from the appropriate electronic crossover output jack and then use the LOW Z INPUT circuitry as the input for the electronic crossover. This feature prevents these jacks from being used as outputs from the LOW Z INPUT circuitry, as was possible with the Channel A input jacks.

LOW Z INPUT(11)

A conventional three-pin, female XLR input jack is also provided here, and it can be used as the channel B input, provided the HI Z INPUT jacks are not being used. When the (PL-2) line-balancing transformer is not used, this XLR input becomes QUASI-BALANCED with the exact same pinout arrangements as discussed for channel A. When the (PL-2) line balancing transformer is used, this XLR input becomes fully TRANSFORMER-BALANCED, again with the same pin polarities as those presented for channel A. (See the PL-2 SELECTOR SWITCH manual section for details on related settings). The output of this low Z

circuitry is always connected to the CROSSOVER INPUTS and thus this low Z feature can be used as the input for the crossover module if the application demands the use of an XLR connector.

PL-2 SELECTOR SWITCH(12)

The function of this switch is identical to that of channel A function. The "OUT" position of this switch selects the QUASI-BALANCED mode of operation for the LOW Z INPUT (XLR jack) and routes this input signal directly to the HI Z INPUT jacks if these jacks are not in use. Since this signal is also routed to the CROSSOVER INPUT jacks, now these jacks may be used as outputs after the LOW Z INPUT to allow patching this signal to another input on this amplifier.

Similarly, the "IN" position of the switch routes the input signals from the XLR jack through the (PL-2) line-balancing transformer thus selecting the TRANSFORMER-BALANCED mode of operation for the LOW Z INPUT. In this position the CROSSOVER INPUTS may be used as outputs after the line-balancing transformer to patch the signal to another input jack on this amplifier or other amps/equipment. Again selecting the "IN" position without a (PL-2) line-balancing transformer IN the receptacle will render the LOW Z INPUT inoperable, and this switch can be used to test the "effectiveness" of TRANSFORMER BALANCING.

TRANSFORMER RECEPTACLE(13)

This receptacle only receives the optional (PL-2) line-balancing transformer. When conditions exist that demand the usage of a TRANSFORMER-BALANCED XLR INPUT at the input of channel "B", or at the input of the PL-MODULE ELECTRONIC CROSSOVER when BIAMPING then the (PL-2) transformer must be put here, and the selector switch must be in the "IN" position.

CROSSOVER INPUTS (14)

These are the HI Z INPUTS for the ELECTRONIC CROSSOVER when installed. Two parallel input jacks are again provided at this point, allowing the flexibility of line out capability here as well. These jacks are also not chassis grounded and will provide a QUASI-BALANCED input capability to minimize potential groundloops. Again, this feature is automatic. As mentioned, the output of the low Z input circuitry of channel B is always connected to these inputs, which allow the LOW Z INPUT to be used as the ELECTRONIC CROSSOVER input if desired. These inputs then can be used as the FULL RANGE outputs allowing additional patching capability.



CAUTION: When a full range signal is patched into either the XLR input or the crossover inputs on channel B to feed the crossover module itself this full range signal is also routed to the channel B input. The final patching from the crossover output to the channel B input disconnects this full range signal feed to the channel B input and instead is patched to the appropriate crossed-over signal. This occurs because the channel B input jacks are switching type. If you were to inadvertently disconnect the cable which is routing the crossed-over signal to the channel B input, the switching arrangement will feed a full range signal to that

channel and could possibly destroy the transducer that is connected to this channel output. ALWAYS REDUCE LEVELS BEFORE ATTEMPTING TO MAKE ANY PATCHING CHANGES.

CROSSOVER MODULE RECEPTACLE (15)

This receptacle only receives a PL-MODULE ELECTRONIC CROSSOVER. The PL-MODULES are optional accessories and are available in many different crossover frequencies. Some modules contain special equalization and special padding for a particular Peavey speaker enclosure. Always be sure to select the correct module for your speaker system. Other special purpose modules are also available for usage in this receptacle. As such this receptacle supplies both the input and output patch facilities and the power supply "feeds" for these active electronic devices.

CROSSOVER LOW OUTPUT (16)

This jack supplies the crossed-over low frequency output from the installed PL-MODULE ELECTRONIC CROSSOVER. This output must be patched to the appropriate power amp input jack to "create" an operational biamp system. On some special purpose modules, this output jack is not used.

CROSSOVER HIGH OUTPUT (17)

This jack supplies the crossed-over high frequency output from the installed PL-MODULE ELECTRONIC CROSSOVER. This output must also be patched to the appropriate power amp input jack to create an operational biamp system.

SPEAKER OUTPUTS (18)

Same function and comments as channel A.

MODE SWITCH (19)

This switch is used to select either STEREO or BRIDGE mode of operation.

DDT SWITCH (20)

This switch is used to either ENABLE or DEFEAT the DDT compressor.

CIRCUIT BREAKER (21)

The CS-800X now uses a circuit breaker in place of the main fuse. This breaker is provided to limit the current to the associated power transformer and thereby protect it from overheating and possible destruction due to fault conditions in the amplifier. The trip current value has been carefully chosen to allow continuous power output performance while still providing adequate protection for the power transformer. Normally this breaker should not trip unless there is a fault in the amplifier circuitry that draws excessive mains current. However, abnormal conditions such as a short circuit on either or both channels or continuous operation at overload or clipping, especially into 2 ohm, load will cause the breaker to trip. If this occurs simply reset the breaker and correct the cause of the overload. When tripped, the button on the breaker will be outward nearly 1/2", and can be reset by pushing inward. A normal reset button length is about 1/4". If this "thermal" type breaker does trip, then simply pushing the button back in will reset it after waiting a brief period of time to allow it to cool down. If the breaker trips instantly each time you attempt to reset it, then the unit should be taken to a qualified service center for repair.



MAINS POWER SOURCE (120 V Products Only) (22)

The CS-800X is fitted with a single heavy duty #14 AWG 3 conductor line cord and a conventional AC plug with a ground pin. It should be connected to an independent mains circuit capable of supporting at least 15 AMPS continuously or greater. This is particularly critical for sustained high power applications. If the socket used does not have a ground pin, a suitable ground lift adaptor should be used and the third wire grounded properly. Never break off the ground pin on the CS-800X. The use of extension cords should be avoided, but if necessary, always use a three-wire type with at least a #14 AWG wire size. The use of lighter wire will severely limit the power capability of this amplifier. Always use a qualified electrician to install any necessary electrical equipment. To prevent the risk of shock or fire hazard, always be sure that the amplifier is properly grounded.

INSTALLATION AND CONNECTION:

The Peavey CS-800X commercial series power amplifier is designed for durability in commercial installations and the quality of performance required in studio and home applications. The unit is a standard rack-mount configuration, 5 1/4" high, and is cooled by an automatic two-speed internal fan. All the input and output connections are on the back panel. The front panel contains LED indicators for power and DDT activation, detented/calibrated sensitivity controls, and a mains power switch.

INDUSTRIAL AND COMMERCIAL INSTALLATIONS

For commercial and other installations, where sustained high power operation is required, the CS-800X should be mounted in a standard 19" rack. It is not necessary to leave rack space between each amplifier in the stack, since the fan pulls air in from the rear and exhausts the hot air out the front. An adequate "COOL" air supply must be provided for the amplifier when rack-mounted. The internal fan must have a source of air that is not preheated by other equipment. The amplifier will start up in "LOW SPEED" fan operation and will normally stay at low speed operation unless sustained high power operating levels occur. Then, as the amplifier "HEAT SINKS" heat up, the automatic thermal sensing circuitry will cause high speed operation to occur. Depending upon signal conditions and amp loading, high speed fan operation may continue, or it may cycle continuously between high and low. This situation is quite normal. If cooling is inadequate due to preheated air, or a reduction of air flow occurs due to blockage of the amplifier inlet/outlet ports, or if the amplifier is severely overloaded or short circuited, then the amplifier thermal sensing system may cause temporary shutdown of that particular channel. This is indicated by the channel power LED (on the front panel) ceasing to illuminate. Depending upon available cooling air, operation should be restored in that channel relatively quickly, and the power LED will be illuminated. In any event, corrective action should be taken to determine the cause of the thermal shutdown. If the amplifier is not severely overloaded or shorted and air flow is normal in and out of the unit, steps should be taken to provide a cooler environment for all the amplifiers. As a general rule, the cooler electronic equipment is operated, the longer its useful service life.

STUDIO AND HOME INSTALLATION:

In most low to medium power applications, the CS-800X can be mounted in any configuration. It is desirable, if at all possible, that the unit be located at the top of an equipment stack.

This will prevent possible overheating of any sensitive equipment by the hot air rising from the power amplifier. As a general rule, most home and studio requirements will never cause high speed fan operation. If it does however, this may indicate that you have not taken the necessary steps to provide adequate cooling. Remember, closed up in a cabinet, the CS-800X will have severe cooling problems, even at low power levels. Again, inadvertent short circuit or sustained overloaded usage could also cause temporary thermal shutdown. Also, most home wiring and electrical circuits are only 15 AMPS. Two CS-800X's could cause a power panel 15 AMP circuit breaker to trip if a severe overload occurs.

BRIDGE MODE:

The bridge mode on stereo amplifiers is often misunderstood as to the actual operation and usage. In basic terms, when a two channel amplifier is operated in the BRIDGE mode, it is converted into a single channel unit with a POWER RATING equal to the sum of both channels' power ratings, at a LOAD RATING of twice that of the single channel rating. In this case, the CS-800X is rated at 600 watts RMS per channel into 2 ohms. The BRIDGE RATINGS is 1200 watts RMS into 4 Ohms (minimum load). Bridge mode operation is accomplished by placing the mode switch in the "BRIDGE" position, connecting the positive speaker lead to Channel A RED binding post, negative speaker lead to Channel B RED binding post, and using channel A as the input channel. All channel B input functions are defeated.

Another application for BRIDGE mode operation is to drive sound distribution systems in very large public address applications. In this mode, the CS-800X power amplifier can actually drive 70 volt systems directly without using expensive matching transformers. The real advantage of such an approach is primarily cost. 70 volt distribution systems are very common in domestic applications where large numbers of relatively small loudspeakers are used for BACKGROUND MUSIC AND PAGING. Such systems require the use of 70 volt TRANSFORMERS at each loudspeaker. Another common use for the BRIDGE mode is in SUBERWOOFER applications where very high power levels are required to reproduce extreme low frequencies. Such enclosures usually contain 2 or 4 loudspeakers to handle the power levels involved. For bridge mode usage, the enclosure impedance must be 4 or 8 ohms; never below 4 ohms! Also make sure the enclosure can handle 1200 watts reliably.

DDT:

Peavey's patented DDT compression circuitry enables the sound man to maximize the performance of the amplifier/speaker combination by preventing the power amp from running out of headroom. This compression system is activated by a very unique circuit that senses signal conditions that might overload the amplifier and activates compression (reduces the amp gain) when clipping is imminent. Threshold of compression is then clipping itself, and no specific threshold control is used. This technique effectively utilizes every precious watt available for the power amplifier to reproduce the signal, while at the same time minimizes clipping and distortion, and thus significantly reduces the potential of loudspeaker degradation and damage. The DDT system is an automatic, hands-off approach to the problem of power amplifier clipping. Since the CS-800X power amplifier now uses a circuit breaker for over-current protection, the DDT compression system plays an even more important roll in continuous performance by preventing each channel from clipping and overload. Continuous operation at clipping can cause the circuit breaker to trip, but with the DDT activated, this problem is minimized. For this reason, you should always have the DDT

BRIDGE MODE

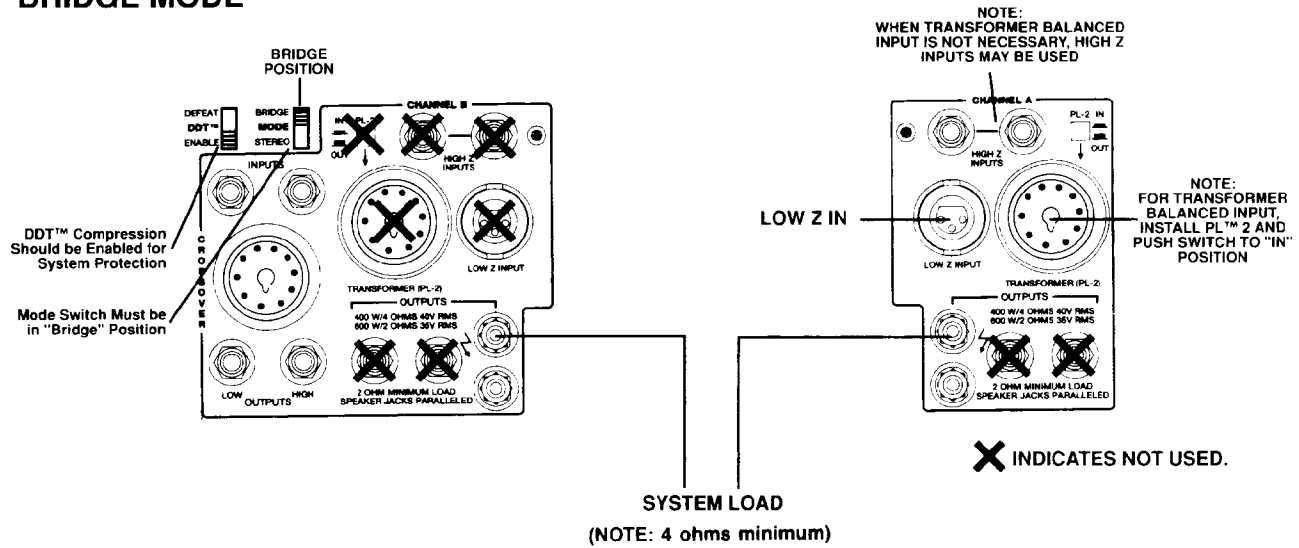

FULL RANGE MONO

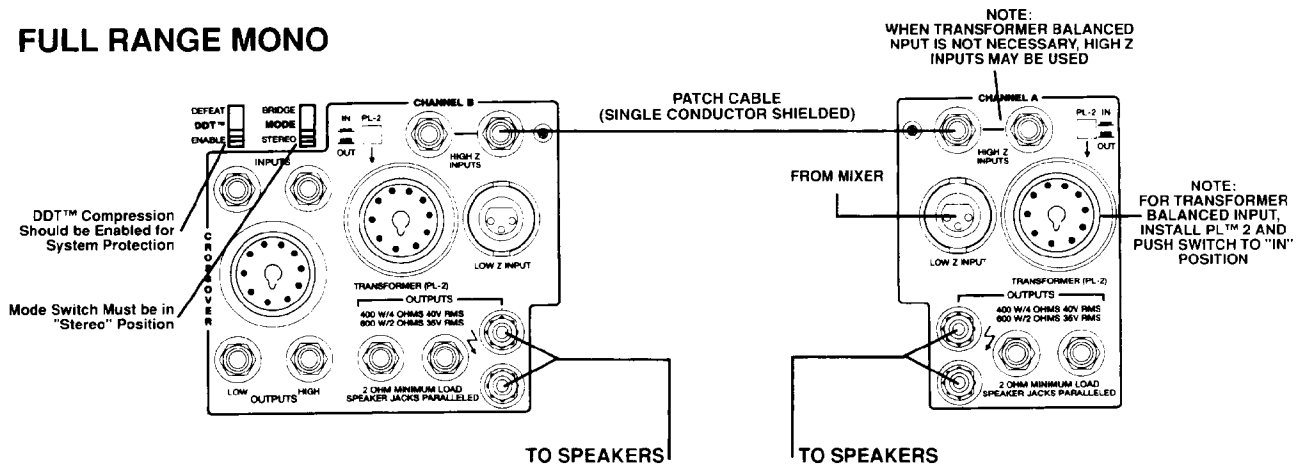

FULL RANGE STEREO

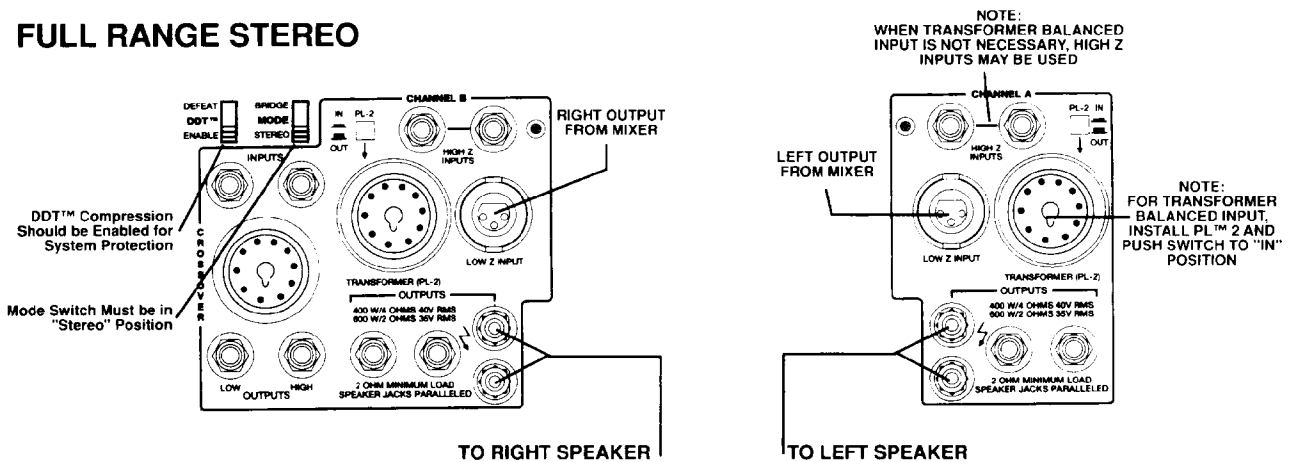

BIAMPED MONO

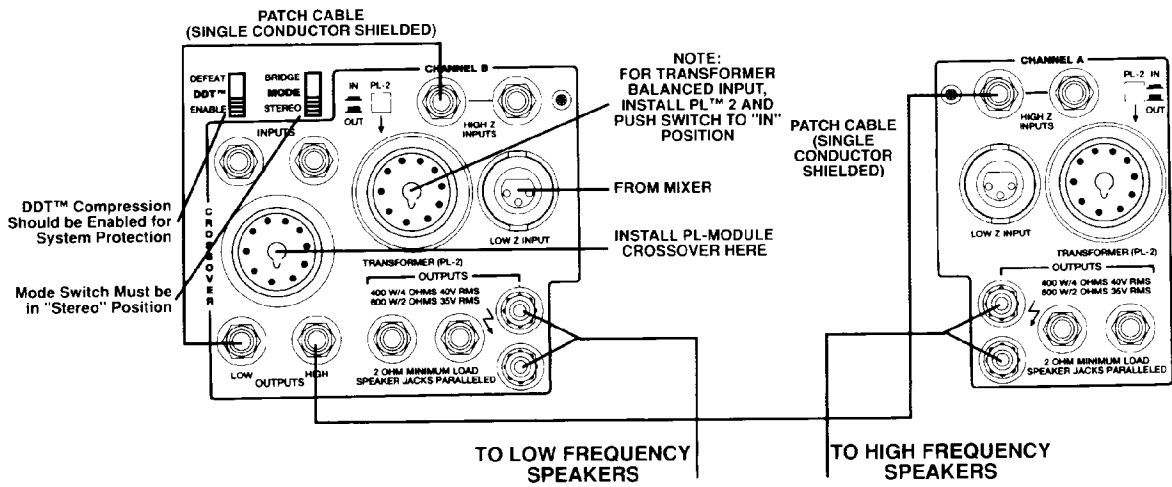

BIAMPED STEREO

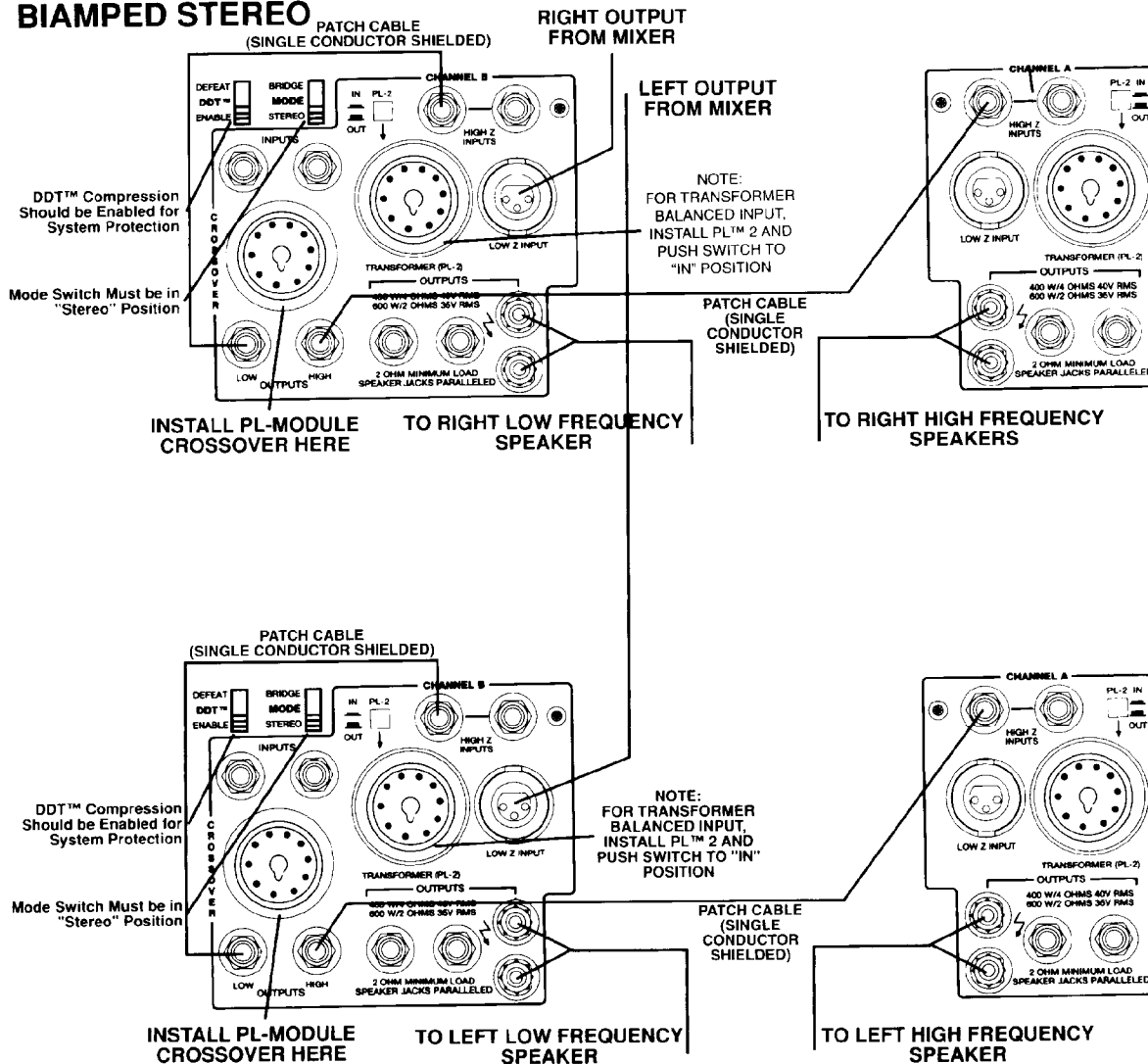

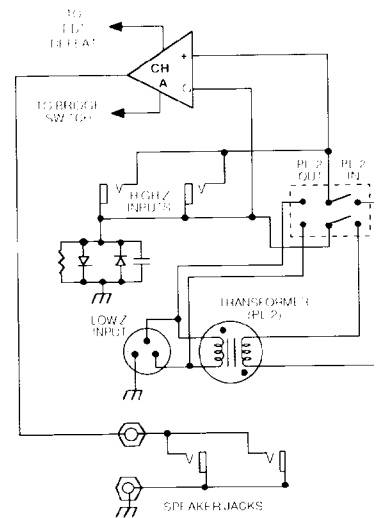
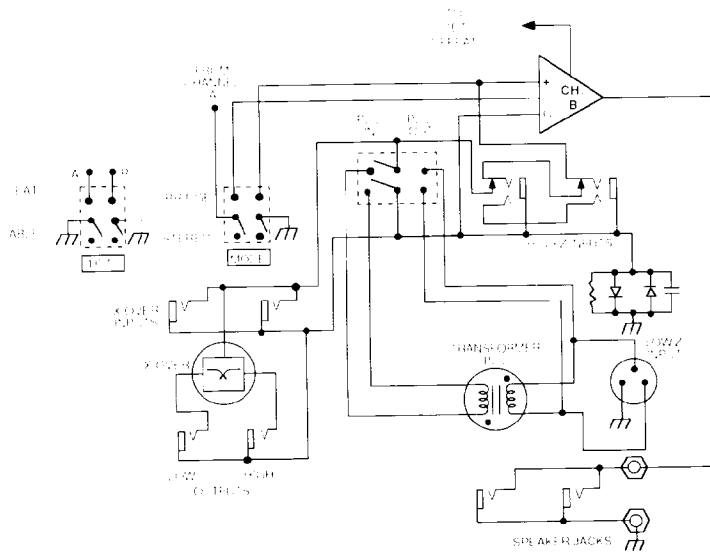

SPECIFICATIONS

CHARACTERISTICS: (@ 120 V AC, 60 Hz)

Output Power: (Typical Value)

Stereo mode, both channels driven

2 ohms, 1 kHz, 1% THD

4 ohms, 1 kHz, 1% THD

8 ohms, 1 kHz, 1% THD

Bridge mode, mono

4 ohms, 1 kHz, 1% THD

8 ohms, 1 kHz, 1% THD

- 600 W RMS per chan
- 420 W RMS per chan
- 260 W RMS per chan

Rated Output Power:

Stereo mode, both channels driven

4 ohms, 20 Hz to 20 kHz, 0.03% THD

8 ohms, 20 Hz to 20 kHz, 0.02% THD

- 400 W RMS per chan
- 240 W RMS per chan

Power Bandwidth: (Typical Value)

Stereo mode, both channels driven

@ rated power, 4 ohms, (0.1% THD)

- 10 Hz to 50 kHz

Slew Rate: (Typical Value)

Stereo mode, each channel

Bridge mode, mono

- 40 Volts per uSec
- 80 Volts per uSec

Total Harmonic Distortion: (Typical)

Stereo mode, both channels driven

20 Hz to 20 kHz, 4 ohm rated output

- Less than 0.03%

Input Sensitivity & Impedance:

Input attenuator set @ FCW

@ rated output power, 4 ohms

- 1.4 V RMS (+3 dBV)
- 20 K Ohms (+29 dB)

Dimensions & Weight:

Height:	-	5.25" (13.3 cm)
Width:	-	19" (48.3 cm)
Depth:	-	17" (43.2 cm)
Weight:	-	47 lbs. (21.4 kg)

Frequency Response: (Typical value)

Stereo mode, both channels driven		
+0, -1 dB, 1 W RMS, 4 ohms	-	5 Hz to 50 kHz
+0, -0.2 dB @ rated output, 4 ohms	-	20 Hz to 20 kHz

Damping Factor: (Typical value)

Stereo mode, both channels driven		
4 ohms, 1 kHz	-	Greater than 200

Hum & Noise:

Stereo mode, both channels driven		
@ rated output power, 4 ohms	-	100 dB, unweighted

Power Consumption:

Stereo mode, both channels driven		
@ rated output power, 4 ohms	-	10 A @ 120 V AC

Cooling System:

- 2 speed fan

DDT™ Compression System:

- Switchable w/LED

THIS LIMITED WARRANTY VALID ONLY WHEN PURCHASED AND REGISTERED IN THE UNITED STATES OR CANADA. ALL EXPORTED PRODUCTS ARE SUBJECT TO WARRANTY AND SERVICES TO BE SPECIFIED AND PROVIDED BY THE AUTHORIZED DISTRIBUTOR FOR EACH COUNTRY. Ces clauses de garantie ne sont valables qu'aux Etats-Unis et au Canada. Dans tous les autres pays, les clauses de garantie et de maintenance sont fixées par le distributeur national et assurées par lui selon la législation en vigueur.

Diese Garantie ist nur in den USA und Kanada gültig. Alle Export-Produkte sind der Garantie und dem Service des Importeurs des jeweiligen Landes unterworfen. Esta garantía es válida solamente cuando el producto es comprado en E.U. continentales o en Canada. Todos los productos que sean comprados en el extranjero, están sujetos a las garantías y servicio que cada distribuidor autorizado determine y ofrezca en los diferentes países.

PEAVEY ONE-YEAR LIMITED WARRANTY/REMEDY

PEAVEY ELECTRONICS CORPORATION ("PEAVEY") warrants this product, EXCEPT for covers, footswitches, patchcords, tubes and meters, to be free from defects in material and workmanship for a period of one (1) year from date of purchase, PROVIDED, however, that this limited warranty is extended only to the original retail purchaser and is subject to the conditions, exclusions, and limitations hereinafter set forth:

PEAVEY 90-DAY LIMITED WARRANTY ON TUBES AND METERS

If this product contains tubes or meters, Peavey warrants the tubes or meters contained in the product to be free from defects in material and workmanship for a period of ninety (90) days from date of purchase; PROVIDED, however, that this limited warranty is extended only to the original retail purchaser and is also subject to the conditions, exclusions, and limitations hereinafter set forth.

CONDITIONS, EXCLUSIONS, AND LIMITATIONS OF LIMITED WARRANTIES

These limited warranties shall be void and of no effect, if:

- a. The first purchase of the product is for the purpose of resale; or
- b. The original retail purchase is not made from an AUTHORIZED PEAVEY DEALER; or
- c. The product has been damaged by accident or unreasonable use, neglect, improper service or maintenance, or other causes not arising out of defects in material or workmanship; or
- d. The serial number affixed to the product is altered, defaced, or removed.

In the event of a defect in material and/or workmanship covered by this limited warranty, Peavey will:

- a. In the case of tubes or meters, replace the defective component without charge.
- b. In other covered cases (i.e., cases involving anything other than covers, footswitches, patchcords, tubes or meters), repair the defect in material or workmanship or replace the product, at Peavey's option; and provided, however, that, in any case, all costs of shipping, if necessary, are paid by you, the purchaser.

THE WARRANTY REGISTRATION CARD SHOULD BE ACCURATELY COMPLETED AND MAILED TO AND RECEIVED BY PEAVEY WITHIN FOURTEEN (14) DAYS FROM THE DATE OF YOUR PURCHASE.

In order to obtain service under these warranties, you must:

- a. Bring the defective item to any PEAVEY AUTHORIZED DEALER or AUTHORIZED PEAVEY SERVICE CENTER and present therewith the ORIGINAL PROOF OF PURCHASE supplied to you by the AUTHORIZED PEAVEY DEALER in connection with your purchase from him of this product.

If the DEALER or SERVICE CENTER is unable to provide the necessary warranty service you will be directed to the nearest other PEAVEY AUTHORIZED DEALER or AUTHORIZED PEAVEY SERVICE CENTER which can provide such service.

OR

- b. Ship the defective item, prepaid, to:

PEAVEY ELECTRONICS CORPORATION
International Service Center
326 Hwy. 11 & 80 East
MERIDIAN, MS 39301

including therewith a complete, detailed description of the problem, together with a legible copy of the original PROOF OF PURCHASE and a complete return address. Upon Peavey's receipt of these items:

If the defect is remedial under these limited warranties and the other terms and conditions expressed herein have been complied with, Peavey will provide the necessary warranty service to repair or replace the product and will return it, FREIGHT COLLECT, to you, the purchaser.

Peavey's liability to the purchaser for damages from any cause whatsoever and regardless of the form of action, including negligence, is limited to the actual damages up to the greater of \$500.00 or an amount equal to the purchase price of the product that caused the damage or that is the subject of or is directly related to the cause of action. Such purchase price will be that in effect for the specific product when the cause of action arose. This limitation of liability will not apply to claims for personal injury or damage to real property or tangible personal property allegedly caused by Peavey's negligence. Peavey does not assume liability for personal injury or property damage arising out of or caused by a non-Peavey alteration or attachment, nor does Peavey assume any responsibility for damage to interconnected non-Peavey equipment that may result from the normal functioning and maintenance of the Peavey equipment.

UNDER NO CIRCUMSTANCES WILL PEAVEY BE LIABLE FOR ANY LOST PROFITS, LOST SAVINGS, ANY INCIDENTAL DAMAGES, OR ANY CONSEQUENTIAL DAMAGES ARISING OUT OF THE USE OR INABILITY TO USE THE PRODUCT, EVEN IF PEAVEY HAS BEEN ADVISED OF THE POSSIBILITY OF SUCH DAMAGES.

THESE LIMITED WARRANTIES ARE IN LIEU OF ANY AND ALL WARRANTIES, EXPRESSED OR IMPLIED, INCLUDING, BUT NOT LIMITED TO, THE IMPLIED WARRANTIES OF MERCHANTABILITY AND FITNESS FOR A PARTICULAR USE; PROVIDED, HOWEVER, THAT IF THE OTHER TERMS AND CONDITIONS NECESSARY TO THE EXISTENCE OF THE EXPRESSED, LIMITED WARRANTIES, AS HEREINABOVE STATED, HAVE BEEN COMPLIED WITH, IMPLIED WARRANTIES ARE NOT DISCLAIMED DURING THE APPLICABLE ONE-YEAR OR NINETY-DAY PERIOD FROM DATE OF PURCHASE OF THIS PRODUCT.

SOME STATES DO NOT ALLOW LIMITATION ON HOW LONG AN IMPLIED WARRANTY LASTS, OR THE EXCLUSION OR LIMITATION OF INCIDENTAL OR CONSEQUENTIAL DAMAGES, SO THE ABOVE LIMITATIONS OR EXCLUSIONS MAY NOT APPLY TO YOU. THESE LIMITED WARRANTIES GIVE YOU SPECIFIC LEGAL RIGHTS, AND YOU MAY ALSO HAVE OTHER RIGHTS WHICH MAY VARY FROM STATE TO STATE.

THESE LIMITED WARRANTIES ARE THE ONLY EXPRESSED WARRANTIES ON THIS PRODUCT, AND NO OTHER STATEMENT, REPRESENTATION, WARRANTY, OR AGREEMENT BY ANY PERSON SHALL BE VALID OR BINDING UPON PEAVEY.

In the event of any modification or disclaimer of expressed or implied warranties, or any limitation of remedies, contained herein conflicts with applicable law, then such modification, disclaimer or limitation, as the case may be, shall be deemed to be modified to the extent necessary to comply with such law.

Your remedies for breach of these warranties are limited to those remedies provided herein and Peavey Electronics Corporation gives this limited warranty only with respect to equipment purchased in the United States of America.

INSTRUCTIONS — WARRANTY REGISTRATION CARD

1. Mail the completed WARRANTY REGISTRATION CARD to:

PEAVEY ELECTRONICS CORPORATION
POST OFFICE BOX 2898
MERIDIAN, MISSISSIPPI 39302-2898

- a. Keep the PROOF OF PURCHASE. In the event warranty service is required during the warranty period, you will need this document. There will be no identification card issued by Peavey Electronics Corporation.
2. IMPORTANCE OF WARRANTY REGISTRATION CARDS AND NOTIFICATION OF CHANGES OF ADDRESSES:
 - a. Completion and mailing of WARRANTY REGISTRATION CARDS — Should notification become necessary for any condition that may require correction, the REGISTRATION CARD will help ensure that you are contacted and properly notified.
 - b. Notice of address changes — If you move from the address shown on the WARRANTY REGISTRATION CARD, you should notify Peavey of the change of address so as to facilitate your receipt of any bulletins or other forms of notification which may become necessary in connection with any condition that require dissemination of information or correction.
3. You may contact Peavey directly by telephoning (601) 483-5365.

IMPORTANT SAFETY INSTRUCTIONS

WARNING: When using electric products, basic cautions should always be followed, including the following.

1. Read all safety and operating instructions before using this product.
2. All safety and operating instructions should be retained for future reference.
3. Obey all cautions in the operating instructions and on the back of the unit.
4. All operating instructions should be followed.
5. This product should not be used near water, i.e., a bathtub, sink, swimming pool, wet basement, etc.
6. This product should be located so that its position does not interfere with its proper ventilation. It should not be placed flat against a wall or placed in a built-in enclosure that will impede the flow of cooling air.
7. This product should not be placed near a source of heat such as a stove, radiator, or another heat producing amplifier.
8. Connect only to a power supply of the type marked on the unit adjacent to the power supply cord.
9. Never break off the ground pin on the power supply cord. For more information on grounding, write for our free booklet "Shock Hazard and Grounding."
10. Power supply cords should always be handled carefully. Never walk or place equipment on power supply cords. Periodically check cords for cuts or signs of stress, especially at the plug and the point where the cord exits the unit.
11. The power supply cord should be unplugged when the unit is to be unused for long periods of time.
12. If this product is to be mounted in an equipment rack, rear support should be provided.
13. Metal parts can be cleaned with a damp rag. The vinyl covering used on some units can be cleaned with a damp rag or an ammonia-based household cleaner if necessary. Disconnect unit from power supply before cleaning.
14. Care should be taken so that objects do not fall and liquids are not spilled into the unit through the ventilation holes or any other openings.
15. This unit should be checked by a qualified service technician if:
 - a. The power supply cord or plug has been damaged.
 - b. Anything has fallen or been spilled into the unit.
 - c. The unit does not operate correctly.
 - d. The unit has been dropped or the enclosure damaged.
16. The user should not attempt to service this equipment. All service work should be done by a qualified service technician.
17. This product should be used only with a cart or stand that is recommended by Peavey Electronics.
18. Exposure to extremely high noise levels may cause a permanent hearing loss. Individuals vary considerably in susceptibility to noise induced hearing loss, but nearly everyone will lose some hearing if exposed to sufficiently intense noise for a sufficient time. The U.S. Government's Occupational Safety and Health Administration (OSHA) has specified the following permissible noise level exposures.

Duration Per Day In Hours	Sound Level dBA, Slow Response
8	90
6	92
4	95
3	97
2	100
1 1/2	102
1	105
1/2	110
1/4 or less	115

According to OSHA, any exposure in excess of the above permissible limits could result in some hearing loss.

Ear plugs or protectors in the ear canals or over the ears must be worn when operating this amplification system in order to prevent a permanent hearing loss if exposure is in excess of the limits as set forth above. To ensure against potentially dangerous exposure to high sound pressure levels, it is recommended that all persons exposed to equipment capable of producing high sound pressure levels such as this amplification system be protected by hearing protectors while this unit is in operation.

SAVE THESE INSTRUCTIONS!



Features and specifications subject to change without notice.

Peavey Electronics Corporation 711 A Street / Meridian, MS 39301 / U.S.A. / (601) 483-5365 / Telex 504115 / Fax 486-1278
©1994 #80301956 Printed in U.S.A. 4/94

Free Manuals Download Website

<http://myh66.com>

<http://usermanuals.us>

<http://www.somanuals.com>

<http://www.4manuals.cc>

<http://www.manual-lib.com>

<http://www.404manual.com>

<http://www.luxmanual.com>

<http://aubethermostatmanual.com>

Golf course search by state

<http://golfingnear.com>

Email search by domain

<http://emailbydomain.com>

Auto manuals search

<http://auto.somanuals.com>

TV manuals search

<http://tv.somanuals.com>