

IP™ SERIES OPERATING GUIDE

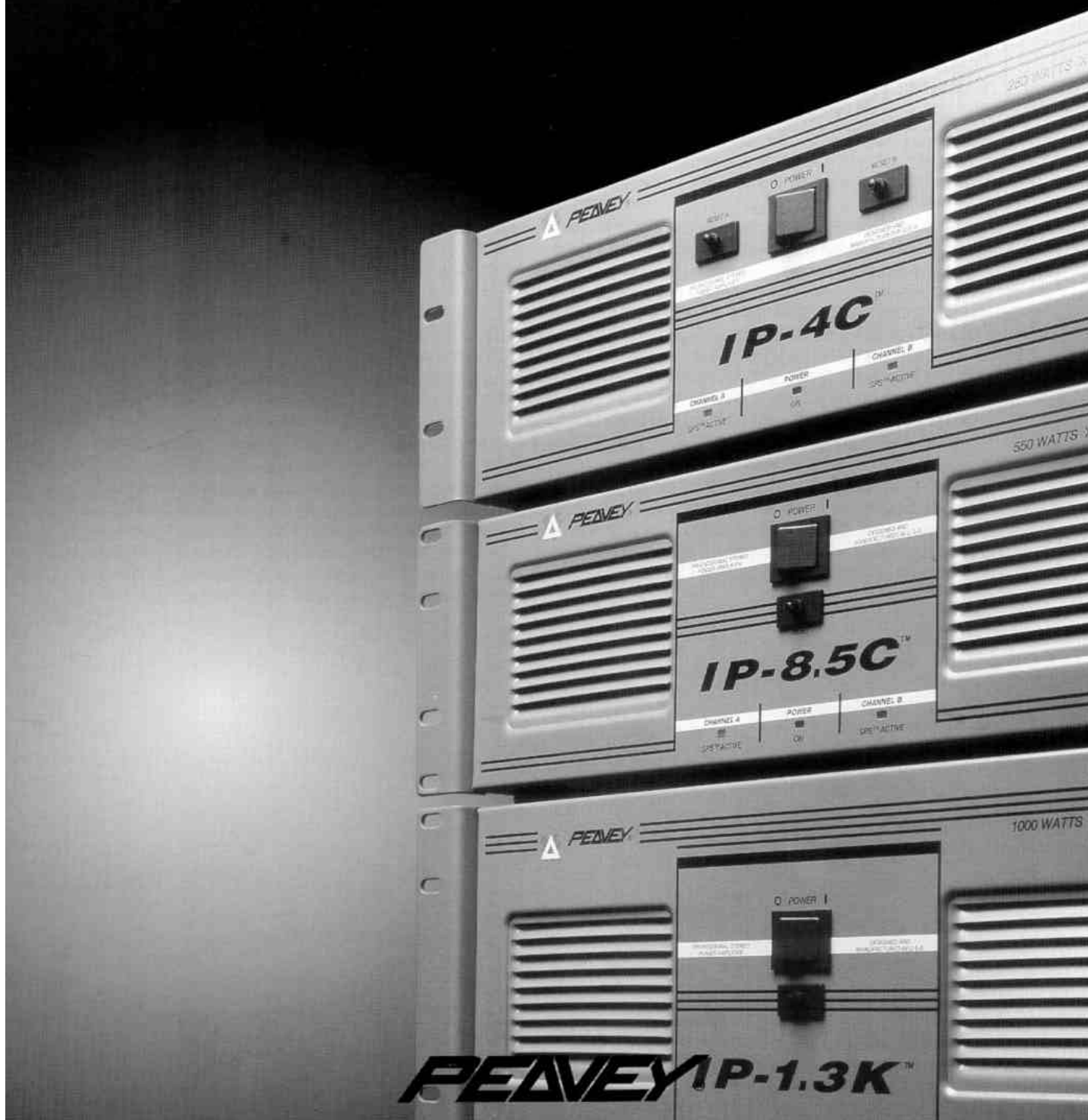



Intended to alert the user to the presence of uninsulated "dangerous voltage" within the product's enclosure that may be of sufficient magnitude to constitute a risk of electric shock to persons.



Intended to alert the user of the presence of important operating and maintenance (servicing) instructions in the literature accompanying the product.

CAUTION: Risk of electrical shock – DO NOT OPEN!

CAUTION: To reduce the risk of electric shock, do not remove cover. No user serviceable parts inside. Refer servicing to qualified service personnel.

WARNING: To prevent electrical shock or fire hazard, do not expose this appliance to rain or moisture. Before using this appliance, read the operating guide for further warnings.

Congratulations! You have just purchased the world's finest, low-cost power amplifier designed especially for the install market -place. Peavey is proud to introduce you to their new IP™ Series. This series combines the latest in semi-conductor technology with the newest approach to power transformer design and a unique, fan-cooled heat sink arrangement to produce a very low cost power amplifier that doesn't sacrifice performance or reliability and will meet the needs of the most demanding sound installation application. The IP Series employs massive power transformers, very effective two speed fan cooling, and offers impressive specifications and features not found on any other competitive unit in this price range. Although designed to drive 4 ohm loads per channel typically, the IP Series amplifiers can also supply impressive high power ratings at 2 ohms per channel and at 4 ohm bridge (mono) mode under music power conditions. Typical public address and paging applications, where signal conditions are less than continuous, can use this new 2 ohms per channel capability most effectively to offer awesome performance levels at a very economical installation cost. The following is a brief summary of the IP specifications:

- IP-4C:** 210 W RMS into 4 ohms; 250 W RMS into 2 ohms (per channel)
420 W RMS into 8 ohms; 500 W RMS into 4 ohms (bridged)
5-1/4" (3 rack space) unit with two speed fan cooling
- IP-8.5C:** 425 W RMS into 4 ohms; 550 W RMS into 2 ohms (per channel)
850 W RMS into 8 ohms; 1100 W RMS into 4 ohms (bridged)
5-1/4" (3 rack space) unit with two speed fan cooling
- IP-1.3K:** 650 W RMS into 4 ohms; 1000 W RMS into 2 ohms (per channel)
1300 W RMS into 8 ohms; 2000 W RMS into 4 ohms (bridged)
7" (4 rack space) unit with two speed fan cooling
- COMMON:** SPS™ compression with LED indicators and defeat switch
Slew Rate: 20 V/microsecond, stereo mode, each channel
Frequency Response: 20 Hz - 20 KHz, ±0.2 dB, rated power
Total Harmonic Distortion: Less than 0.1%, rated power
Hum and Noise: 100 dB below rated power, unweighted

Each amplifier is attractively packaged with rugged rack-mountable construction and more than adequate patching capability. The front panel of each amplifier contains a rocker mains switch, a resettable circuit breaker, an LED power indicator, and dual LED SPS activation indicators. The back panel of each amplifier has a detented input level control, a single 1/4" phone input jack, 5-way binding post outputs, and a single 1/4" phone output jack, and barrier strips for both input and output for each channel. Additionally, the back panel contains switches for stereo/bridge select and SPS defeat.

This operating guide is intended to serve all three of the IP Series power amplifiers. Although each has different power ratings, serves all of the PV Series power amplifiers. Although each has different power ratings, the overall packaging and features are similar. Wherever differences occur, those will be pointed out.

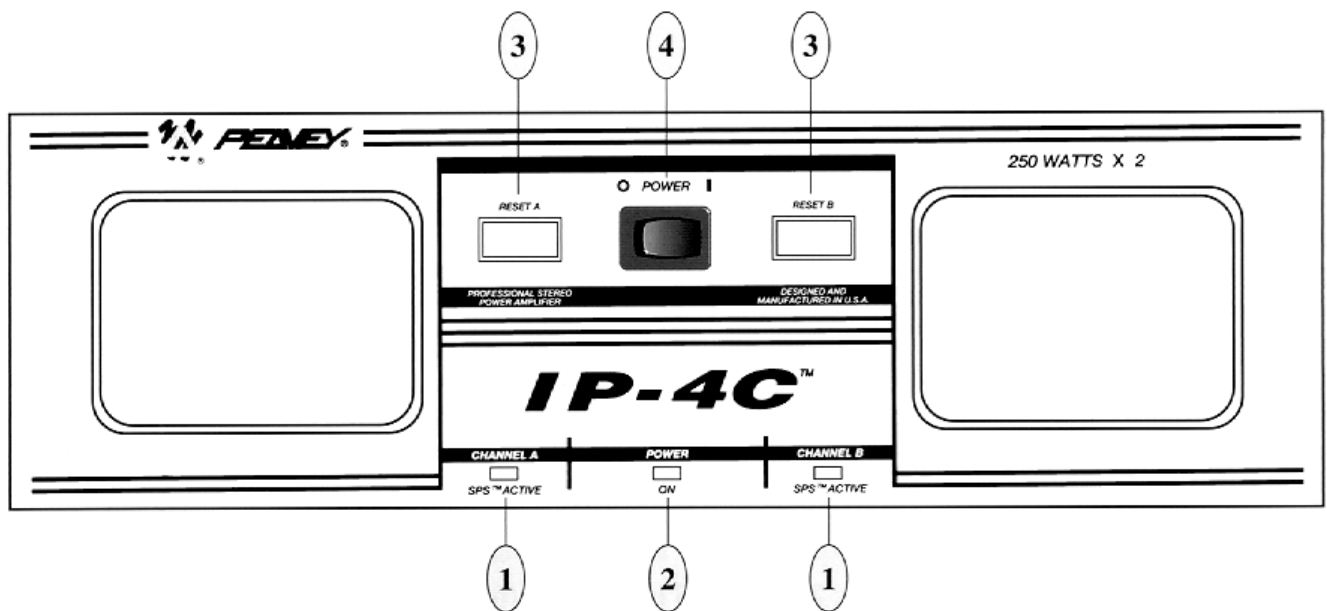

SPS™ ACTIVE LED (1)

Illuminates when SPS compression is taking place in the channel. With the ENABLE/DEFEAT switch on the back panel in the DEFEAT position, this LED indicates when channel clipping is occurring.

POWER LED (2)

Illuminates when AC mains power is being supplied to the amp and both channels are operational. If either channel were to experience fault conditions, exceed the safe operating temperature limits, or have the associated circuit breaker trip, then the power LED will go out indicating such conditions exist.



CIRCUIT BREAKER (3)

On the IP™-4C there are two, one for each channel. On the IP™-8.5C and the IP™-1.3K there is only one. These breakers are provided to limit the current to the associated power transformer and, thereby, protect it from overheating and possible destruction due to fault conditions in the amplifier. The trip current values have been carefully chosen to allow continuous power output performance while still protecting the power transformer. Normally, these breakers should not trip unless there is a fault in the amplifier circuitry that draws excessive mains current. However, abnormal conditions such as a short circuit on either or both channels or continuous operation at overload or clipping (especially into 2 ohm load) will cause the breaker(s) to trip. If this occurs, simply reset the breaker and correct the cause of the overload. When tripped, the button on the breaker will be outward nearly 1/2", and can be reset by pushing inward. A normal reset button length is about 1/4". If this "thermal" type breaker does trip, then simply pushing the button back in will reset it, after waiting a brief period of time to allow it to cool down. If the breaker trips instantly each time you attempt to reset it, the unit should be taken to a qualified service center for repair.

MAINS POWER SWITCH (4)

A heavy duty, rocker-type switch (selecting the O position) turns off the power amplifier.

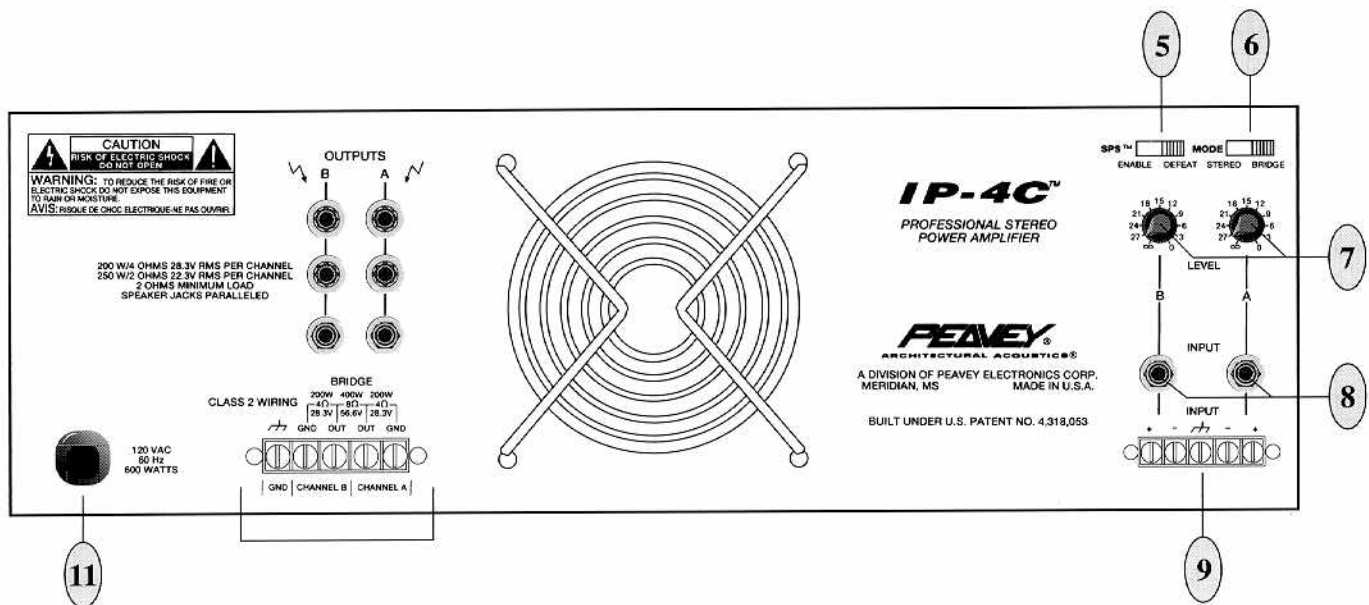

SPS™ SWITCH (5)

This switch is used to either ENABLE or DEFEAT the DDT™ compressor. Normally the DDT function should be enabled to minimize the possibility of either or both channels going into clipping or overload. With SPS defeated, a severe overload could cause the mains circuit breakers to trip as a matter of course. *(The Peavey SPS compression system will be covered in greater detail later in this manual.)*

MODE SWITCH (6)

This switch is used to select either STEREO or BRIDGE mode of operation. Care should be exercised whenever the BRIDGE mode is selected. Accidental selection of this mode could damage loudspeakers, particularly in BIAMPED systems. The BRIDGE mode will be covered in greater detail later in this manual.

INPUT LEVEL (7)

Controls used to adjust the input sensitivity of each channel. These controls are detented, allowing about a 1 dB adjustment of input sensitivity rating per detent. Maximum input gain (minimum sensitivity rating) is achieved at the full clockwise setting, and this setting yields maximum mixer/system headroom. A setting of less than full clockwise will yield lower system noise at the expense of mixer/system headroom. Although not very accurate near the extremes of the control range, each numbered detent from 3 to 21 is within a small fraction of a dB of the actual input gain reduction value in dB (pad). This of course is also the reduction in system sound pressure levels below the full power out value.

HIGH Z INPUT JACK (8)

A single input jack is provided for each channel for convenience if needed. This jack is in parallel with the associated barrier strip terminals, thus permitting either patch to be used as a conventional input, and simultaneously the other patch to be used as a "line-out" (Y-cord) to connect to another input jack on this amplifier or other amps or equipment. This 1/4" input jack is not "chassis grounded" and when used will provide a QUASI-BALANCED input capability due to the unique "ground loop" elimination circuitry associated with each input. This features will normally allow "hum free" operation when relatively short 1/4" cable patches are made between the jack on this amp and other jacks on various other equipment that share the same rack with this amp. This QUASI-BALANCED capability is automatic and fool-proof, but it can be defeated with jumpers on the associate barrier strip. *(See next section.)*

BARRIER STRIP INPUTS (9)

A second way "in", again in parallel with the 1/4" input jack for each channel, this feature allows direct connection of input cables without using a phone plug. The center screw of this five terminal strip is chassis ground. Each channel HIGH Z input is on the end screws marked "+," and each channel "QUASI" ground is on the next screws marked "-." Always connect single conductor shielded cables to each channel with the center conductor on the "+" and the shield on the "-." For balanced feeds using two conductor shielded cables, connect the positive "feed" to the respective "-" screws, and both shields to the ground center screw. (A diagram is provided later in this manual showing this wiring.) To defeat the QUASI-BALANCED input capability of either or both channels, connect a jumper between the ground screw and the associated "-" screw for each channel. (Again, a diagram is included on this.)



SPEAKER OUTPUTS (10)

5-way binding post terminals, one 1/4" phone jack, and a barrier strip is provided for speaker outputs each channel. Again, for each channel, these outputs are all in parallel, thus the speaker connection cables can be terminated with banana plugs, 1/4" phone plugs, or stripped wires for use in the binding post terminals or the barrier strip. For sustained high power applications, the use of the binding post terminals or the barrier strip. For sustained high power applications the use of either the binding post or the barrier strip terminals are recommended, however care must be exercised to assure correct speaker phasing. Regardless of what connections are used, the typical parallel speaker load should always be limited to 2 ohms per channel or 4 ohms BRIDGE mode for any application. Operation at loads of 4 ohms per channel or 8 ohms BRIDGE mode is more desirable for sustained operation applications due to the fact that these amplifier will run much cooler at this load, and at these load conditions, the IP Series has a much longer continuous operating capability. Operation above 4 ohms per channel and even sustained operation at loads below 2 ohms could result in temporary amplifier shutdown due to the thermal limits and/or the amplifier internal fault circuitry.



MAINS POWER SOURCE (120V products only) (11)

All the IP Series power amplifiers are fitted with a single, heavy duty 3-conductor line cord and a conventional AC plug with a ground pin. It should be connected to an independent circuit capable of supporting at least 15 AMPS or greater continuously. This is particularly critical for sustained high power applications. If the socket used does not have a ground pin, a suitable ground lift adaptor should be used and the third wire grounded properly. **Never break off the ground pin on any equipment. It is provided for your safety.** The use of extension cords should be avoided but, if necessary, always use a three-wire type with at least a #14 AWG wire size. The use of lighter wire will severely limit the power capability of this power amplifier. Always use a qualified electrician to install any new electrical equipment. To prevent the risk of shock or fire hazard, always be sure that the amplifier is properly grounded.

INSTALLATION AND CONNECTION:

The PV professional series of power amplifiers is designed for durability in commercial installations and has the quality of performance required in studio and home applications. These units are a standard rack-mount configuration height, and each is cooled by an automatic two-speed internal fan. All input and output connections are on the back panel. Additionally, the level controls and selector switches are on the back panel. The front panel contains LED indicators for power & DDT activation, the mains power switch, and the resettable circuit breaker(s).

INDUSTRIAL AND COMMERCIAL INSTALLATIONS:

For commercial and other installations where sustained high power operation is required, the amplifiers should be mounted in a standard 19" rack. It is not necessary to leave a rack space between each amplifier in the stack since each fan pulls air in from the rear and exhausts the hot air out the front. However, an adequate "COOL" air supply must be provided for the amplifier when rack-mounted. The internal fan must

have a source of air that is not preheated by other equipment. The amplifier will start up in "low speed" fan operation and will normally stay at low speed operation unless sustained high power operating levels occur. Then, as the amplifier "heat sinks" heat up, the automatic thermal sensing circuitry will cause high speed operation to occur. Depending upon signal conditions and amp loading, high speed fan operation may continue or it may cycle continuously between high and low. This situation is quite normal. If cooling is inadequate due to preheated air or a reduction of air flow occurs due to blockage of the amplifier inlet/outlet ports or if the amplifier is severely overloaded or short circuited, the amplifier thermal sensing system may cause temporary shutdown of the unit. This is indicated by the power LED on the front panel ceasing to illuminate. Depending upon the available cooling air, operation should be restored relatively quickly, and the power LED will be illuminated. In any event, corrective action should be taken to determine the cause of the thermal shutdown. If the amplifier is not severely overloaded or shorted and air flow is normal in and out of the amplifier, then steps should be taken to provide a cooler environment for all the amplifiers. As a general rule, the cooler electronic equipment is operated, the longer its useful service life.

BRIDGE MODE:

The bridge mode on stereo amplifiers is often misunderstood as to the actual operation and usage. In basic terms, when a two channel amplifier is operated in the BRIDGE mode, it is converted into a single channel unit with a POWER RATING equal to the sum of both channels' power ratings at a LOAD RATING of twice that of the single channel rating. For example, the IP-4C is rated at 250 watts RMS per channel into 2 ohms. The BRIDGE RATINGS are 500 watts RMS into 4 ohms (minimum load). Bridge mode operation is accomplished by placing the mode switch in the "BRIDGE" position, connecting the load between the RED binding posts of each channel, and using channel A as the input channel. All channel B input functions as an input are defeated, and they serve no purpose now.

A popular application for BRIDGE mode operation is to drive sound distribution systems in large public address applications. In this mode any of the IP Series power amplifier can actually drive 70 volt systems directly without using matching transformers. The real advantage of such an approach is primarily cost. 70 volt distribution systems are very common in domestic applications where large numbers of relatively small loudspeakers are used for BACKGROUND MUSIC AND PAGING. Such systems require the use of 70 volt TRANSFORMERS at each loudspeaker. Another common use for the BRIDGE mode is in SUBWOOFER applications where very high power levels are required to reproduce extreme low frequencies. Such enclosures usually contain 2 or 4 loudspeakers to handle the power levels involved. For bridge mode usage, the enclosure impedance must be 4 or 8 ohms - never below 4 ohms!

SPS™ :

Peavey's patented SPS™ compression system maximize the performance of the amplifier/speaker combination by preventing the power amp from running out of headroom (clipping). This compression

system is activated by a very unique circuit that senses signal conditions which might overload the amplifier and activates compression (reduces the amp gain) when clipping is imminent. Threshold of compression, then, is clipping itself, and no specific threshold control is used. This technique effectively utilizes every precious watt available for the power amplifier to reproduce the signal while at the same time minimizes clipping and distortion and thus significantly reduces the potential of loudspeaker degradation and damage. The SPS system is an automatic hands-off approach to the problem of power amplifier clipping. Since the PV Series power amplifiers use circuit breakers for "over current" protection, the DDT compression system plays even a more important role in continuous performance by preventing each channel from clipping and overload. Continuous operation at clipping can cause the circuit breakers to trip, but with the DDT activated, this problem is minimized. For this reason, you should always have the DDT compression system enabled.

STEREO MODE

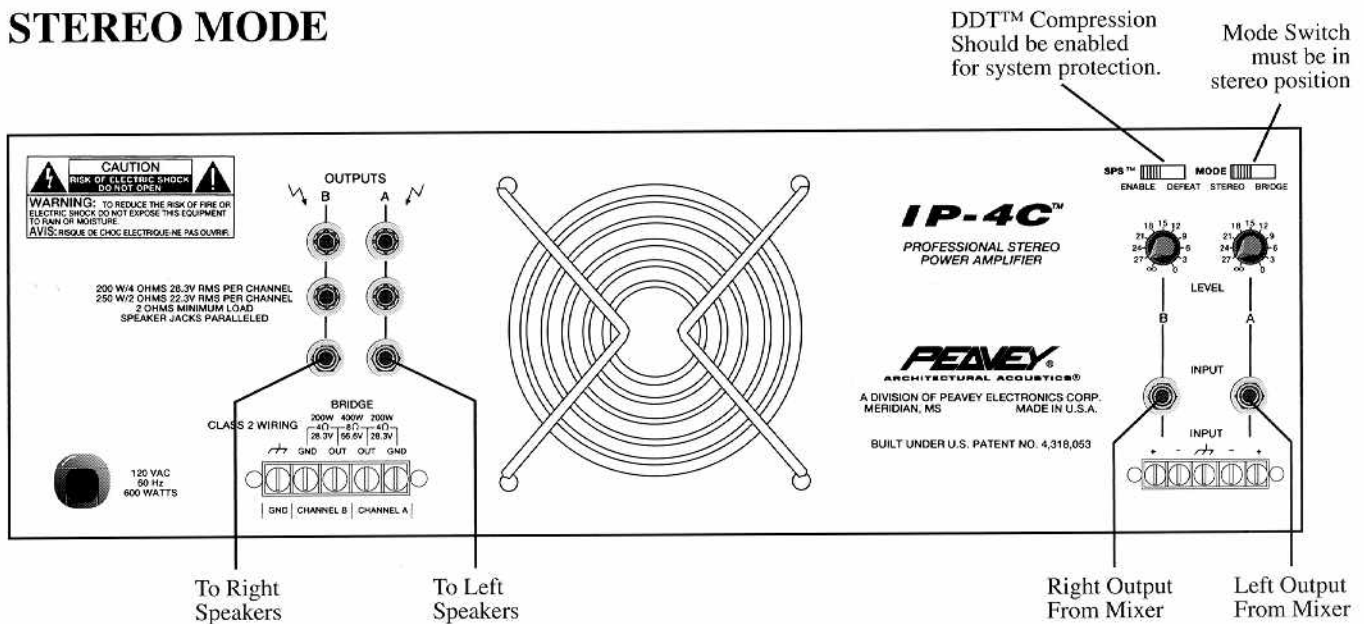

TWO CHANNEL MONO MODE

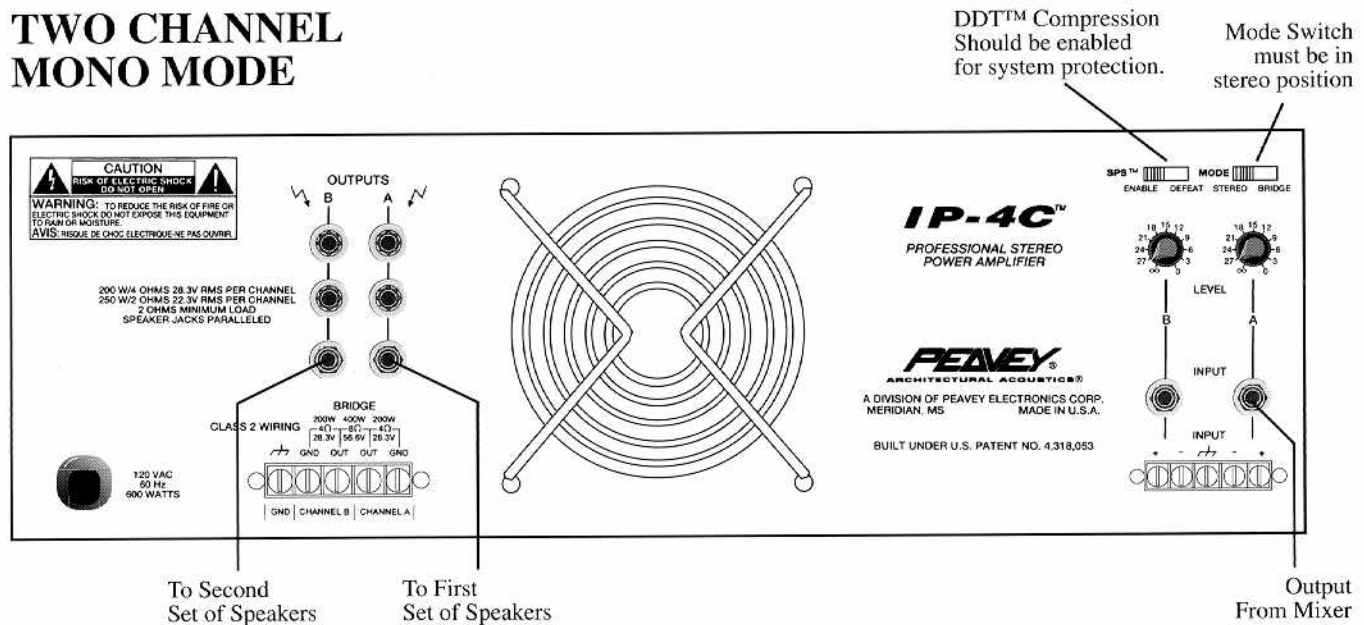

BRIDGE MODE

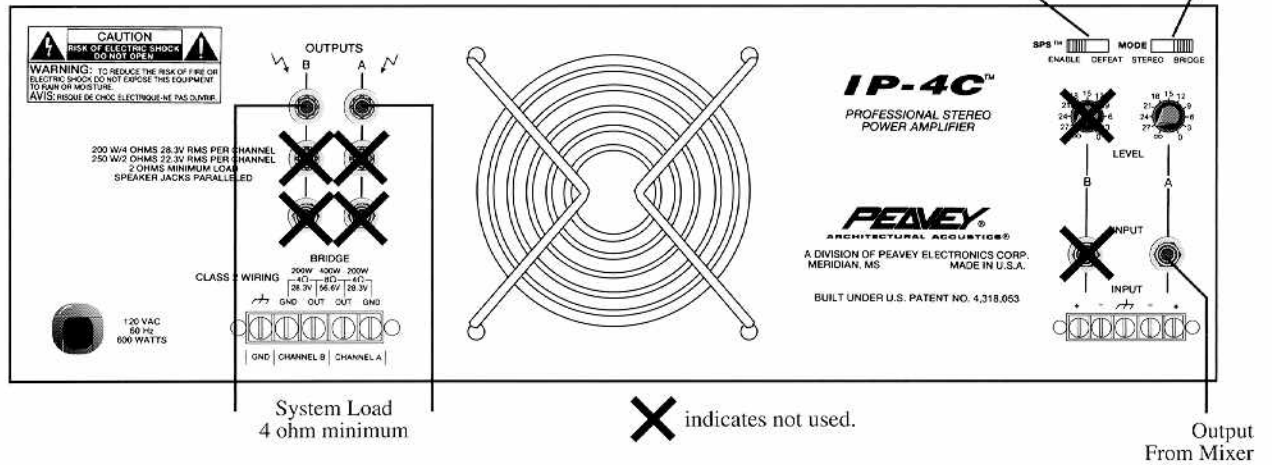

STEREO MODE ALTERNATE INPUT/OUTPUT

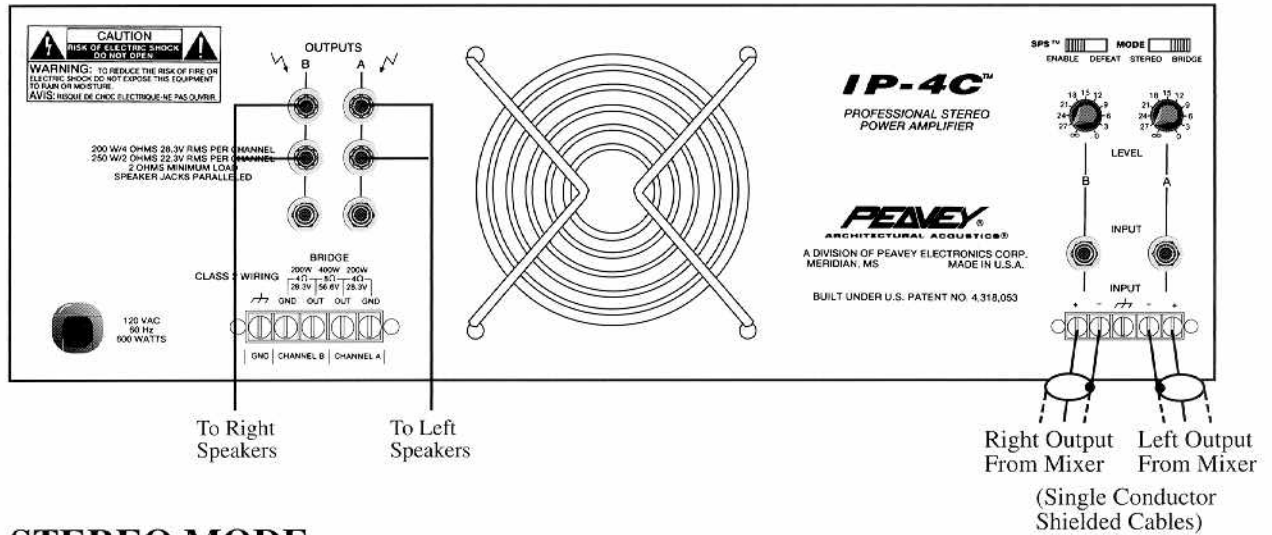

STEREO MODE ALTERNATE INPUT/OUTPUT

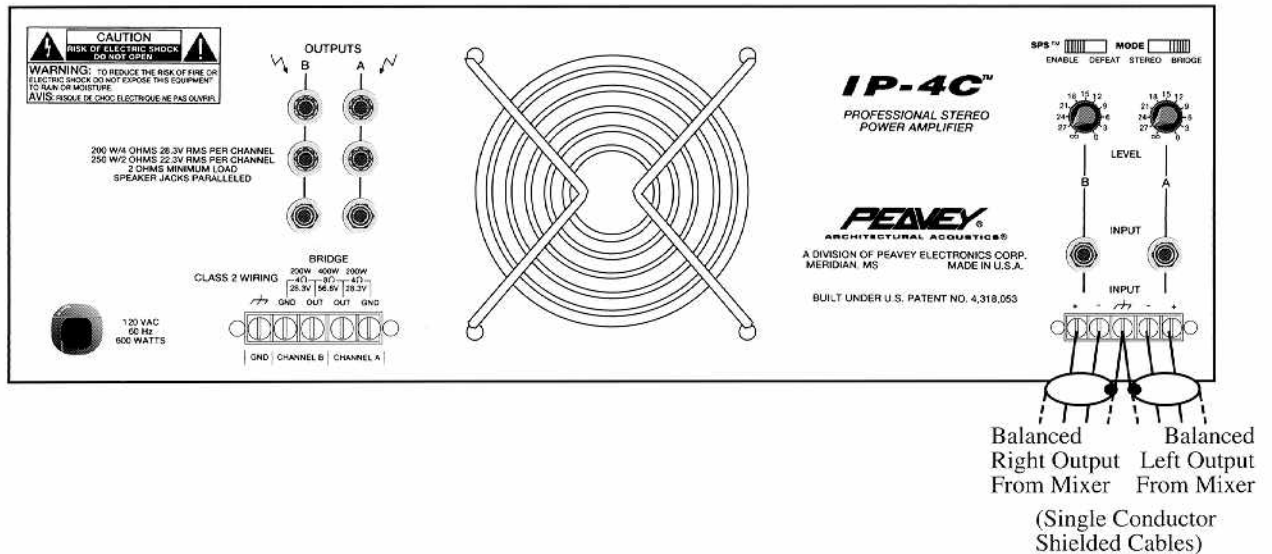

SPECIFICATIONS

CHARACTERISTICS ¹	IP-4C	IP-8.5C	IP-1.3K
Output Power^{2,3}:			
2 ohms, 1 kHz, 1% THD	250 W RMS per channel	550 W RMS per channel	1000 W RMS per channel
4 ohms, 1 kHz, 1% THD	210 W RMS per channel	425 W RMS per channel	650 W RMS per channel
8 ohms, 1 kHz, 1% THD	130 W RMS per channel	270 W RMS per channel	400 W RMS per channel
(Bridge mode, mono)			
4 ohms, 1 kHz, 1% THD	500 W RMS	1100 W RMS	2000 W RMS
8 ohms, 1 kHz, 1% THD	420 W RMS	850 W RMS	1300 W RMS
Rated Output Power²:			
4 ohms, 20 Hz - 20 kHz, 0.15% THD	200 W RMS per channel	400 W RMS per channel	600 W RMS per channel
8 ohms, 20 Hz - 20 kHz, 0.1% THD	120 W RMS per channel	240 W RMS per channel	360 W RMS per channel
Slew Rate³:			
Stereo mode, each channel	20 Volts per uSec	20 Volts per uSec	20 Volts per uSec
Bridge mode, mono	40 Volts per uSec	40 Volts per uSec	40 Volts per uSec
Total Harmonic Distortion^{2,3}:			
20 Hz - 20 kHz, @ rated output power, 8 ohms	Less than 0.1%	Less than 0.1%	Less than 0.1%
Input Sensitivity & Impedance⁴:			
@ rated output power, 8 ohms	1.0 V RMS (0 dBV) 20 K ohms (29 dB gain)	1.0 V RMS (0 dBV) 20 K ohms (32 dB gain)	1.0 V RMS (0 dBV) 20 K ohms (34 dB gain)
Dimensions & Weight:			
Height	5.25" (13.3 cm)	5.25" (13.3 cm)	7" (17.8 cm)
Width	19" (48.3 cm)	19" (48.3 cm)	19" (48.3 cm)
Depth	9" (22.9 cm)	13" (33.0 cm)	14" (35.6 cm)
Weight	30 lbs. (13.6 kg)	45 lbs. (20.5 kg)	55 lbs. (25.0 kg)
Frequency Response^{2,3}:			
±1 dB, 1 W RMS, 8 ohms	10 Hz - 40 kHz	10 Hz - 40 kHz	10 Hz - 40 kHz
±0.2 dB, @ rated output, 8 ohms	20 Hz - 20 kHz	20 Hz - 20 kHz	20 Hz - 20 kHz
Damping Factor^{2,3}:			
8 ohms, 1 kHz	Greater than 300	Greater than 300	Greater than 300
Hum & Noise²:			
Below rated output power, 8 ohms	100 dB, unweighted	100 dB, unweighted	100 dB, unweighted
Power Consumption²:			
@ rated output power, 8 ohms	4.4 A @ 120 V AC	8.6 A @ 120 V AC	12.7 A @ 120 V AC
Cooling System:	2 speed fan	2 speed fan	2 speed fan
SPS™ Compression System:	Switchable with LED	Switchable with LED	Switchable with LED

¹ (@ 120 V AC, 60 Hz) ² (Stereo mode, both channels driven) ³ (Typical Value) ⁴ (Input attenuator set FCW)

LIMITED WARRANTY

Peavey Electronics Corporation warrants to the original purchaser of this new Architectural Acoustics product that it is free from defects in material and workmanship. If within one (1) year from date of purchase a properly installed product proves to be defective and Peavey is notified, Peavey will repair or replace it at no charge. (Note: Batteries and patch cords not covered.) "Original purchaser" means the customer for whom the product is originally installed.

Damage resulting from improper installation, interconnection of a unit or system of another manufacturer, accident or unreasonable use, neglect or any other cause not arising from defects in material, and workmanship is not covered by this warranty. The warranty is valid only as to products purchased and installed in the United States.

THIS LIMITED WARRANTY IS IN LIEU OF ANY AND ALL WARRANTIES, EXPRESSED OR IMPLIED, INCLUDING THE IMPLIED WARRANTIES OF MERCHANTABILITY AND FITNESS FOR A PARTICULAR USE. UNDER NO CIRCUMSTANCES WILL PEAVEY BE LIABLE FOR ANY LOST PROFITS, LOST SAVINGS, INCIDENTAL DAMAGES OR CONSEQUENTIAL DAMAGES ARISING OUT OF THE USE OR INABILITY TO USE THE PRODUCT, EVEN IF PEAVEY HAS BEEN ADVISED OF THE POSSIBILITY OF SUCH DAMAGE. THIS LIMITED WARRANTY IS THE ONLY EXPRESSED WARRANTY ON THIS PRODUCT, AND NO OTHER STATEMENT, REPRESENTATION, WARRANTY, OR AGREEMENT BY ANY PERSON SHALL BE VALID OR BINDING UPON PEAVEY.

Peavey's liability to the original purchaser for damages for any cause whatsoever and regardless of the form of action, is limited to the actual damages up to the greater of Five Hundred Dollars (\$500) or an amount equal to the purchase price of the product that caused the damage or that is the subject of or is directly related to the cause of action. This limitation of liability will not apply to claims for personal injury or damage to real property or tangible personal property allegedly caused by Peavey's negligence. For information on service under this warranty, call a Peavey customer service representative at (601) 483-5376.

IMPORTANT SAFETY INSTRUCTIONS

WARNING: When using electric products, basic cautions should always be followed, including the following:

1. Read all safety and operating instructions before using this product.
2. All safety and operating instructions should be retained for future reference.
3. Obey all cautions in the operating instructions and on the back of the unit.
4. All operating instructions should be followed.
5. This product should not be used near water, i.e., a bathtub, sink, swimming pool, wet basement, etc.
6. This product should be located so that its position does not interfere with its proper ventilation. It should not be placed flat against a wall or placed in a built-in enclosure that will impede the flow of cooling air.
7. This product should not be placed near a source of heat such as a stove, radiator, or another heat producing amplifier.
8. Connect only to a power supply of the type marked on the unit adjacent to the power supply cord.
9. Never break off the ground pin on the power supply cord. For more information on grounding, write for our free booklet "Shock Hazard and Grounding."
10. Power supply cords should always be handled carefully. Never walk or place equipment on power supply cords. Periodically check cords for cuts or signs of stress, especially at the plug and the point where the cord exits the unit.
11. The power supply cord should be unplugged when the unit is to be unused for long periods of time.
12. If this product is to be mounted in an equipment rack, rear support should be provided.
13. Metal parts can be cleaned with a damp rag. The vinyl covering used on some units can be cleaned with a damp rag or an ammonia-based household cleaner if necessary. Disconnect unit from power supply before cleaning.
14. Care should be taken so that objects do not fall and liquids are not spilled into the unit through the ventilation holes or any other openings.
15. This unit should be checked by a qualified service technician if:
 - a. The power supply cord or plug has been damaged.
 - b. Anything has fallen or been spilled into the unit.
 - c. The unit does not operate correctly.
 - d. The unit has been dropped or the enclosure damaged.
16. The user should not attempt to service this equipment. All service work should be done by a qualified service technician.
17. This product should be used only with a cart or stand that is recommended by Peavey Electronics.
18. Exposure to extremely high noise levels may cause a permanent hearing loss. Individuals vary considerably in susceptibility to noise induced hearing loss, but nearly everyone will lose some hearing if exposed to sufficiently intense noise for a sufficient time. The U.S. Government's Occupational Safety and Health Administration (OSHA) has specified the following permissible noise level exposures.

Duration Per Day In Hours	Sound Level dBA, Slow Response
8	90
6	92
4	95
3	97
2	100
1 1/2	102
1	105
1/2	110
1/4 or less	115

According to OSHA, any exposure in excess of the above permissible limits could result in some hearing loss.

Ear plugs or protectors in the ear canals or over the ears must be worn when operating this amplification system in order to prevent a permanent hearing loss if exposure is in excess of the limits as set forth above. To ensure against potentially dangerous exposure to high sound pressure levels, it is recommended that all persons exposed to equipment capable of producing high sound pressure levels such as this amplification system be protected by hearing protectors while this unit is in operation.

SAVE THESE INSTRUCTIONS!



Features and specifications subject to change without notice.

A Division of Peavey Electronics Corporation

711 A Street / Meridian, MS 39302-2898 / U.S.A. / (601) 483-5376 / Telex 504115 / Fax 486-1278

©1993

#80301958

Printed in U.S.A. 10/93

Free Manuals Download Website

<http://myh66.com>

<http://usermanuals.us>

<http://www.somanuals.com>

<http://www.4manuals.cc>

<http://www.manual-lib.com>

<http://www.404manual.com>

<http://www.luxmanual.com>

<http://aubethermostatmanual.com>

Golf course search by state

<http://golfingnear.com>

Email search by domain

<http://emailbydomain.com>

Auto manuals search

<http://auto.somanuals.com>

TV manuals search

<http://tv.somanuals.com>