

OPERATING INSTRUCTIONS



Intended to alert the user to the presence of uninsulated "dangerous voltage" within the product's enclosure that may be of sufficient magnitude to constitute a risk of electric shock to persons.



Intended to alert the user to the presence of important operating and maintenance (servicing) instructions in the literature accompanying the product.

CAUTION: Risks of electrical shock—DO NOT OPEN
CAUTION: To reduce the risk of electric shock, do not remove cover. No user serviceable parts inside. Refer Servicing to qualified service personnel.

UA™ 35T II

Utility Amplifier





WARNING!

DO NOT ATTEMPT TO INSTALL THIS UNIT WHILE IT OR ANY CONNECTING UNITS ARE POWERED ON. RISK OF ELECTRICAL SHOCK EXISTS IF ALL UNITS ARE NOT POWERED OFF DURING INSTALLATION. TO PREVENT ELECTRICAL SHOCK OR FIRE HAZARD, DO NOT EXPOSE THIS APPLIANCE TO RAIN OR MOISTURE.

FEATURES

- 35 watts into 4 ohms
- Mic/page inputs (screw terminals)
- Mic/page select switch
- Dedicated program input (screw terminals and RCA jacks)
- Bass and treble controls
- Mic/page level control
- AUX level control
- Direct 4 ohms output (screw terminals)
- Completely isolated 8 ohms, 25 volt, and 70 volt outputs (screw terminals)
- Shelf-top or wall-mountable chassis

DESCRIPTION

The UA™ 35T II is a high quality utility amplifier ideally suited for varying installation requirements. It produces 35 watts into 4 ohms and 8 ohms direct connections plus a broad range of line amplification. Level controls are provided for mic/page and AUX. The mic/page input is accessed via screw terminals or RCA jacks. Bass and treble controls are functional on the total system (mic/page/AUX). When a signal is present at the mic/page input, the AUX input is muted. This feature is internally defeatable when required.

Twenty-five and seventy volt line output capability is standard equipment, and the unit is packaged for shelf or wall mounting convenience. The user-friendly control layout, coupled with state-of-the-art circuit design, ensure reliable long-term operation and smooth trouble-free installation.

WALL OR SHELF MOUNTING

The UA 35T II can be mounted on a vertical or horizontal surface using the brackets formed on the bottom panel. For mounting on a wooden or paneled surface, use No. 6 x 1/2" or larger wood screws. For mounting onto a masonry or drywall type surface, use fasteners that are designed for this purpose.

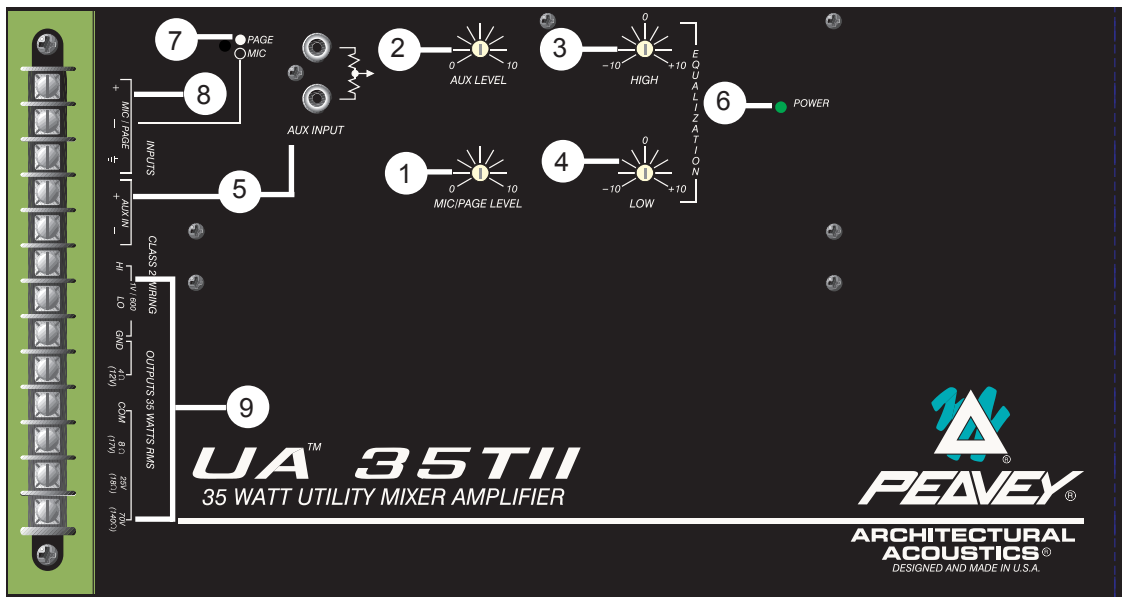

MIC/PAGE LEVEL CONTROL (1)

Controls the signal level at the mic/page inputs. (See mic/page switch (7).)

AUX LEVEL CONTROL (2)

Controls the signal level at the AUX inputs.

HIGH EQ CONTROL (TREBLE) (3)

Active equalization control that adjusts the high frequency response. Clockwise rotation boosts highs while counterclockwise rotation provides a cut (reduction) of the high frequencies (± 10 dB).

LOW EQ CONTROL (BASS) (4)

Active equalization control that adjusts the low frequency response. Clockwise rotation boosts lows while counterclockwise rotation provides a cut (reduction) of the low frequencies (± 10 dB).

AUX IN (5)

Accepts signals from other sources, such as another mixer or background music source. Signal level at this input is controlled by the AUX level control and is fed to the Master output.

POWER LED (6)

Green LED illuminates when power is being supplied to the unit.

MIC/PAGE SWITCH (7)

Selects between mic and page input. The page selection provides internal pad, converting this input to line level for page applications.

INPUTS (8)

Low Z mic/page inputs are provided via screw terminals. Screw terminal AUX inputs are paralleled with AUX RCA jacks. (See AUX IN (5).)

OUTPUTS (9)

A direct output, as well as several transformer outputs, are provided to allow the proper interface between the amplifier and the speaker system. The direct output allows direct connection to a 4 ohms speaker system. Connect the speaker (or speakers) from the GND terminal to the 4 ohms terminal. For 8 ohms speaker systems, connect between the COM terminal and the 8 ohms terminal.

25 V and 70 V outputs are also provided for "constant voltage" speaker distribution systems. The 25 V and 70 V output

connection is between the COM terminal and the 25 V or 70 V terminal.

FUSE (10)

The fuse is located within the cap of the fuseholder. If the fuse should fail, **IT MUST BE REPLACED WITH THE SAME TYPE AND VALUE IN ORDER TO AVOID DAMAGE TO THE EQUIPMENT AND TO PREVENT VOIDING THE WARRANTY.** If the amp repeatedly blows fuses, it should be taken to a qualified service center for repair.

WARNING: THE FUSE SHOULD ONLY BE REPLACED WHEN THE POWER CORD HAS BEEN DISCONNECTED FROM ITS POWER SOURCE.

AC LINE CORD SOCKET (11)

Provided to accept the removable AC line cord. Connect only to proper source--see back panel markings.

POWER SWITCH (12)

Used to turn AC mains power on or off.

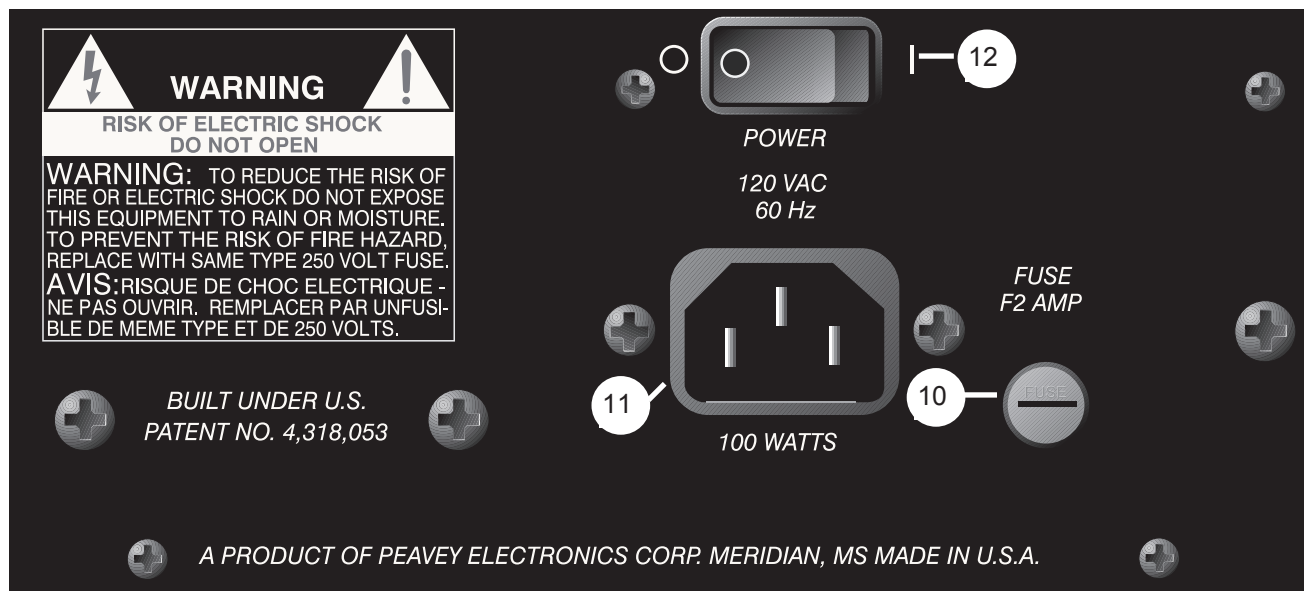

BLOCK DIAGRAM

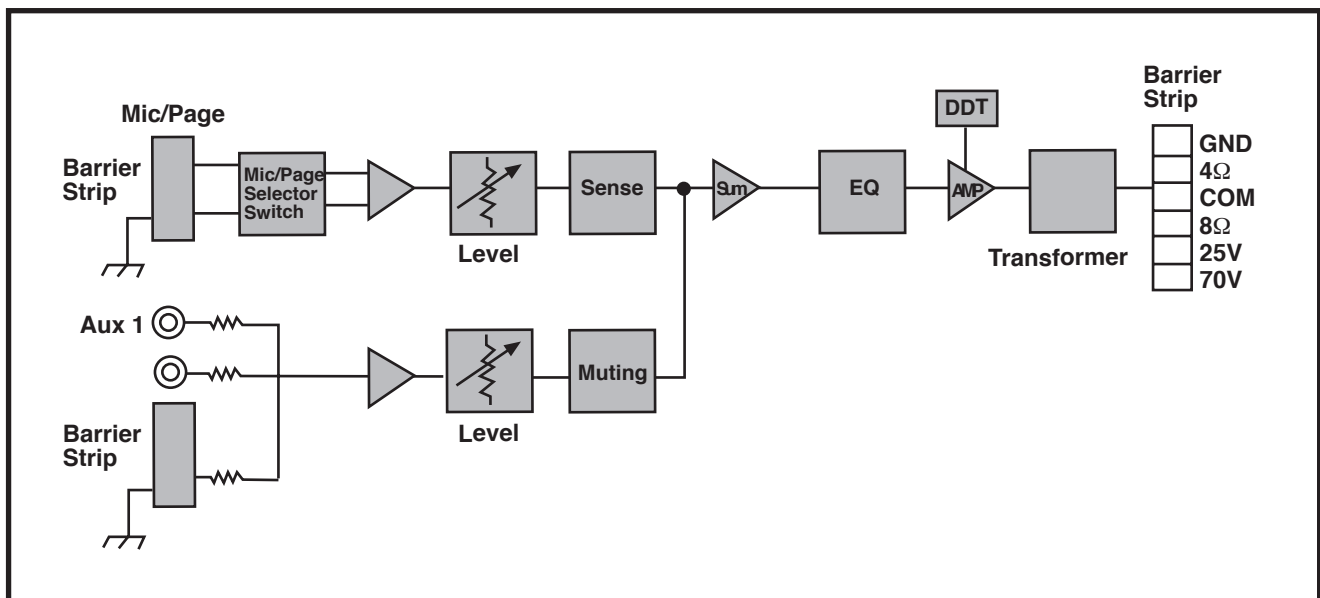

WIRING DIAGRAM

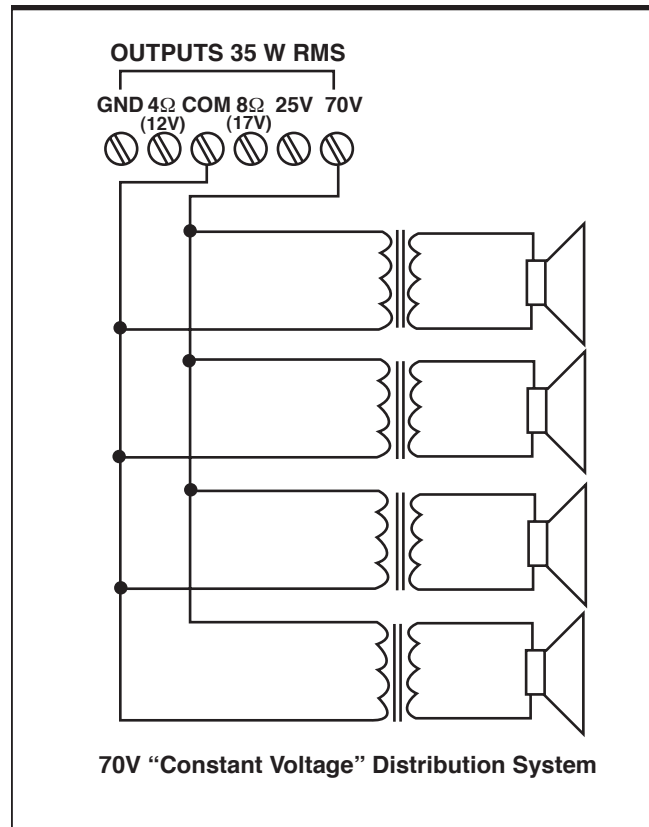

UA 35T Specifications

OUTPUT POWER:

35 watts RMS

POWER BANDWIDTH:

Aux 50 Hz - 20 kHz .6% THD

Mic 50 Hz - 20 kHz .8% THD

Page 50 Hz - 20 kHz .6% THD

FREQUENCY RESPONSE:

Aux 50 Hz - 20 kHz +0, -2 dB

Mic 50 Hz - 20 kHz +0, -2 dB

Page 50 Hz - 20 kHz +0, -2 dB

THD (1 kHz):

Aux <.05%

Mic <.2%

Page <.2%

S/N RATIO (22 kHz BW):

Tone controls flat/input control max

Aux 85 dB (50 ohm input)

Mic 58 dB (150 ohm input)

Page 58 dB (680 ohm input)

tone controls:

Bass +/- 10 dB @ 100 Hz

Treble +/- 10 dB @ 10 kHz

INPUTS:

Aux Input: Dual RCA phono jacks, summed

Mic/Page Input: Screw terminal input switchable between mic/page

INPUT SENSITIVITY:

Aux Input: 100mV @ 10K ohms

Mic Input: 1mV @ 1K ohms

Page Input: 120mV @ 5K ohms

OUTPUTS:

4 ohms, 8 ohms, 25 V, 70 V

OUTPUT REGULATION:

Less than 0.5 dB, no load to full load

CONTROLS:

1 Aux input gain control, 1 mic/page gain control, 1 bass control, 1 treble control, 1 mic/page select switch

INDICATORS:

Power LED

PROTECTION:

Built-in, with AC line fuse

POWER CONSUMPTION:

120 volts AC, 60 Hz, 100 watts

DIMENSIONS:

4.25" H x 8.25" W x 13.625" D

WEIGHT:

11.5 pounds

COLOR:

Gray

OTHER FEATURES:

Mic/page input has precedence over the Aux input (defeatable)

IMPORTANT SAFETY INSTRUCTIONS

WARNING: When using electric products, basic cautions should always be followed, including the following.

1. Read all safety and operating instructions before using this product.
2. All safety and operating instructions should be retained for future reference.
3. Obey all cautions in the operating instructions and on the back of the unit.
4. All operating instructions should be followed.
5. This product should not be used near water, i.e., a bathtub, sink, swimming pool, wet basement, etc.
6. This product should be located so that its position does not interfere with its proper ventilation. It should not be placed flat against a wall or placed in a built-in enclosure that will impede the flow of cooling air.
7. This product should not be placed near a source of heat such as a stove, radiator, or another heat producing amplifier.
8. Connect only to a power supply of the type marked on the unit adjacent to the power supply cord.
9. Never break off the ground pin on the power supply cord. For more information on grounding, write for our free booklet "Shock Hazard and Grounding."
10. Power supply cords should always be handled carefully. Never walk or place equipment on power supply cords. Periodically check cords for cuts or signs of stress, especially at the plug and the point where the cord exits the unit.
11. The power supply cord should be unplugged when the unit is to be unused for long periods of time.
12. If this product is to be mounted in an equipment rack, rear support should be provided.
13. Metal parts can be cleaned with a damp rag. The vinyl covering used on some units can be cleaned with a damp rag or an ammonia-based household cleaner if necessary. Disconnect unit from power supply before cleaning.
14. Care should be taken so that objects do not fall and liquids are not spilled into the unit through the ventilation holes or any other openings.
15. This unit should be checked by a qualified service technician if:
 - a. The power supply cord or plug has been damaged.
 - b. Anything has fallen or been spilled into the unit.
 - c. The unit does not operate correctly.
 - d. The unit has been dropped or the enclosure damaged.
16. The user should not attempt to service this equipment. All service work should be done by a qualified service technician.
17. This product should be used only with a cart or stand that is recommended by Peavey Electronics.
18. Exposure to extremely high noise levels may cause a permanent hearing loss. Individuals vary considerably in susceptibility to noise induced hearing loss, but nearly everyone will lose some hearing if exposed to sufficiently intense noise for a sufficient time. The U.S. Government's Occupational Safety and Health Administration (OSHA) has specified the following permissible noise level exposures.

Duration Per Day In Hours	Sound Level dBA, Slow Response
8	90
6	92
4	95
3	97
2	100
1 1/2	102
1	105
1/2	110
1/4 or less	115

According to OSHA, any exposure in excess of the above permissible limits could result in some hearing loss. Ear plugs or protectors in the ear canals or over the ears must be worn when operating this amplification system in order to prevent a permanent hearing loss if exposure is in excess of the limits as set forth above. To ensure against potentially dangerous exposure to high sound pressure levels, it is recommended that all persons exposed to equipment capable of producing high sound pressure levels such as this amplification system be protected by hearing protectors while this unit is in operation.

SAVE THESE INSTRUCTIONS!



Features and specifications subject to change without notice.

Peavey Electronics Corporation / 711 A Street, MS 39301 / U.S.A. / (601) 483-5376 / Fax 486-1154

© 1997



80304366

Printed in U.S.A. 10/97

Free Manuals Download Website

<http://myh66.com>

<http://usermanuals.us>

<http://www.somanuals.com>

<http://www.4manuals.cc>

<http://www.manual-lib.com>

<http://www.404manual.com>

<http://www.luxmanual.com>

<http://aubethermostatmanual.com>

Golf course search by state

<http://golfingnear.com>

Email search by domain

<http://emailbydomain.com>

Auto manuals search

<http://auto.somanuals.com>

TV manuals search

<http://tv.somanuals.com>