

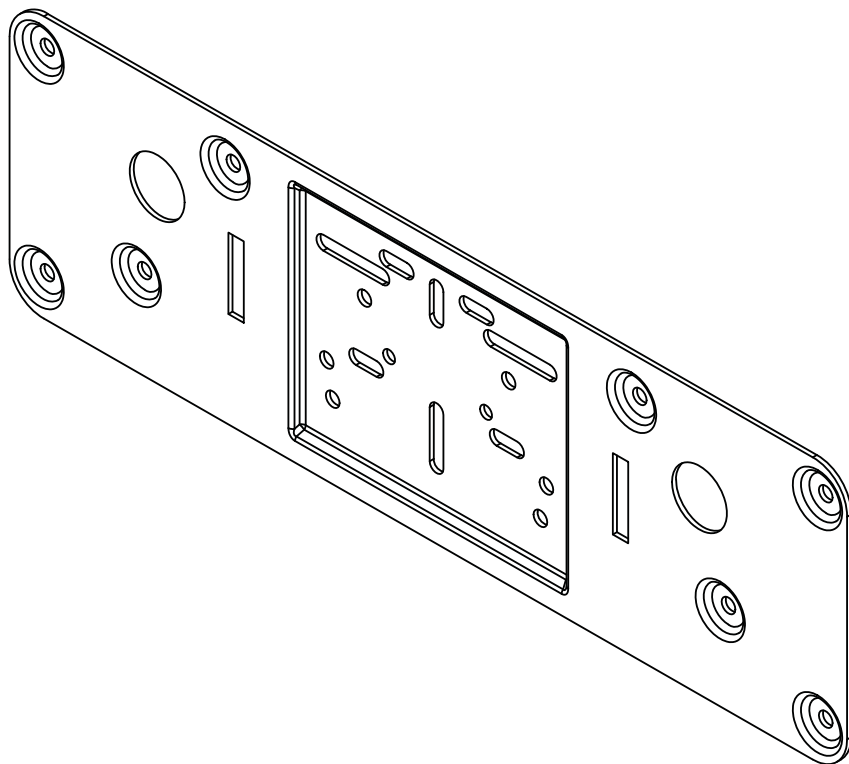

Installation and Assembly

Flat-Panel Base Lock-Down Kit For Philips Display Models

Models: HLG452-002, HLG452-002-Q10



Maximum Display Weight: 100 lb (45.35 kg)

NOTE: Read instruction sheet before you start installation and assembly.

Parts may appear slightly different than illustrated.

Before you begin, make sure all parts shown are included with your product.

Description	HLG452-002		HLG452-002-Q10	
	Qty.	Part #	Qty.	Part #
A lock-down plate	1	090-1757	10	090-1757
B 1/4-20 x 1 3/4" carriage bolt	2	520-1017	20	520-1017
C plastic cap	2	590-1294	20	590-1294
D 1/4-20 slope nut	3	530-0035	30	530-0035
E adhesive strip	4	570-0017	40	570-0017

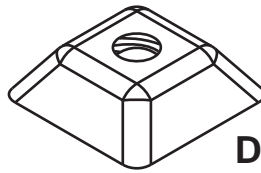
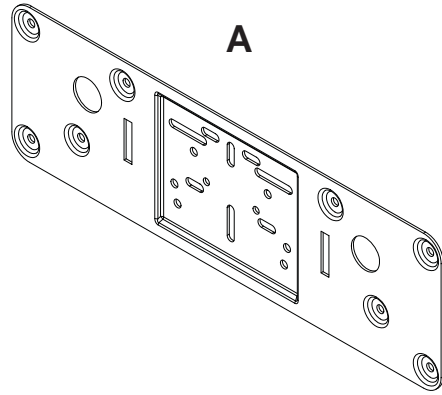

Tools Needed for Assembly

- drill
- 1/4" drill bit
- 5/8" open box wrench
- phillips screwdriver
- 5/32 allen wench
- 3M™ Rubber & Vinyl 80 Spray Adhesive (generic name: Contact 80 Neoprene Vinyl Spray Adhesive)

This product can be found at hardware and craft stores, as well as on the 3M website: <http://solutions.3m.com/>.

Accessory

- **ACC939** - 1/4-20 x 2.25" carriage screws for thicker desktop surfaces
- **MIS660** - Neck Security Screws for 26HFL5830D/27, 32HFL5460D/27, 32HFL5860D/27, 32HF7965D/27, 37HFL5560D/27, 42HFL5860D/27, 42HFL7580A/27, 52HFL5580D/27
- **ACC943**: Installation Template (plate only)

Installation Option 1 (Fasteners) Pages 3 and 4

Installation Option 2 (Adhesive Strips) Pages 5 and 6

Installation Option 1 (Fasteners) DISPLAY MODEL HOLE PATTERNS

A. SBP240M/27

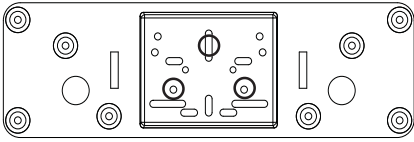

SCREWS SUPPLIED BY DISPLAY
MANUFACTURER

- B.** 42HF7945D/27
37HFL5560D/27
42HFL55860D/27
42HFL7945D/27
42HFL7580A/27
52HFL5580D/27

- C.** 26HFL5830D/27
32HFL5460D/27
32HFL5860D/27
32HFL7560D/27
32HF7965D/27
32HFL7965D/27

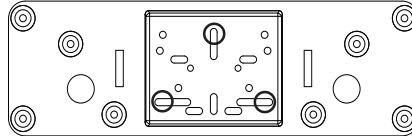

SCREWS SUPPLIED BY DISPLAY
MANUFACTURER

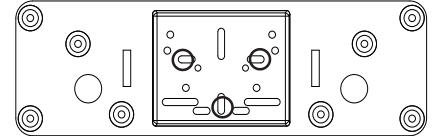

SCREWS SUPPLIED BY DISPLAY
MANUFACTURER

- 1** Use lock-down plate (A) as a template to mark location of holes, point 1 and point 2, approximately 7" apart on table. Drill two holes using a 1/4" drill bit.

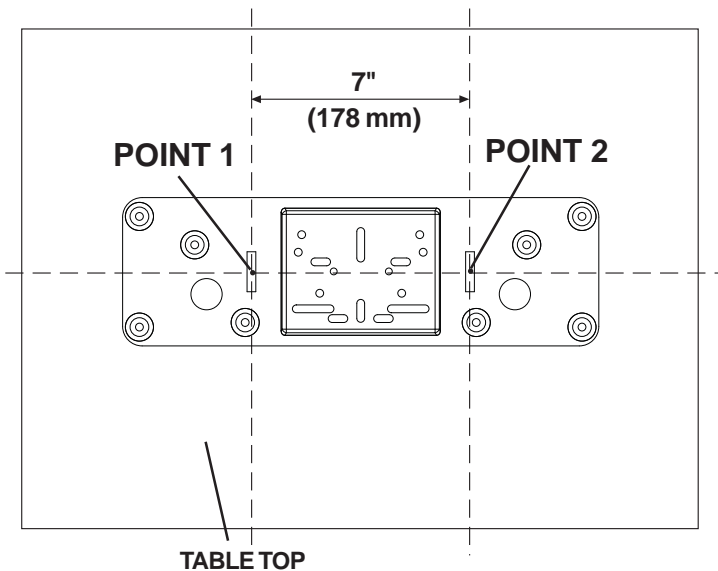

- 2** Slide two 1/4-20 x 1 3/4" bolts (B) through slots as shown below.

NOTE: 2 1/4" carriage bolts (ACC939) are available for use with thicker mounting surfaces.

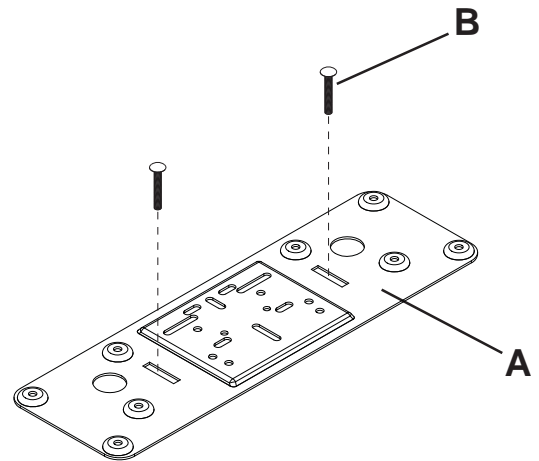

- 3** Attach lock-down plate to display base bottom using screws provided by manufacturer. Refer to page three for lock-down plate/ display base stand hole pattern.
NOTE: Remove existing rubber feet from display base that interfere with the lock-down plate.

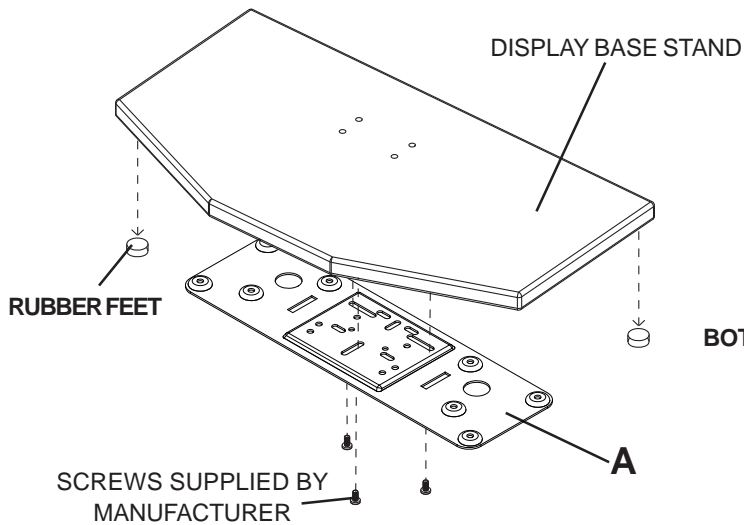

NOTE: Display base stand and mounting hole locations may appear different than illustrated.

- 4** Hand tighten slope nut (D) through 1/4-20 x 1 3/4" screw bolt (B) until snug against bottom of desktop surface. Thread another slope nut (D) upside-down, about two turns from first slope nut (D). Insert an open box wrench between both slope nuts (D) and tighten.
NOTE: Avoid jamming both slope nuts (D) together, doing so may make it difficult to remove slope nut used for tightening first slope nut (D). After slope nut is secure remove bottom slope nut and add plastic cap (C) as shown in figure 4.2. Repeat with remaining 1/4-20 x 1 3/4" screw bolt (B).

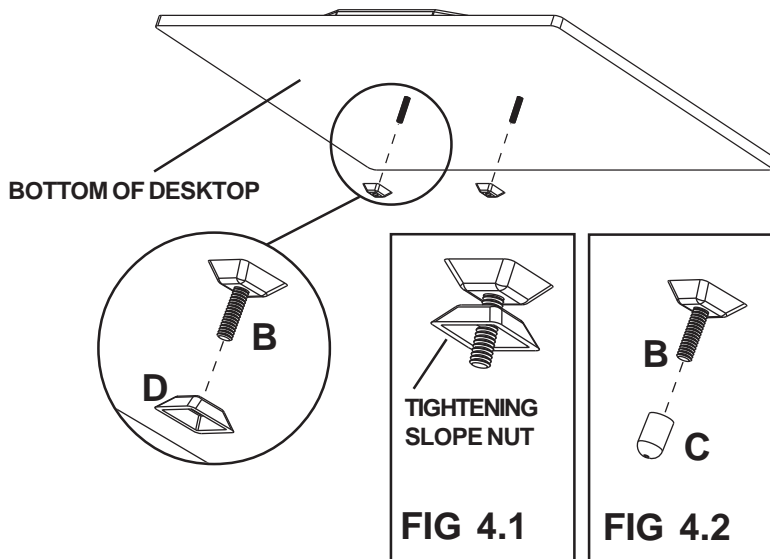
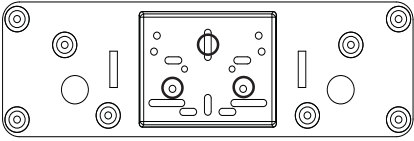

FIG 4.1

FIG 4.2

Installation Option 2 (Adhesive Strips) DISPLAY MODEL HOLE PATTERNS

A. SBP240M/27



SCREWS SUPPLIED BY DISPLAY
MANUFACTURER

B. 42HF7945D/27 37HFL5560D/27 42HFL55860D/27 42HFL7945D/27 42HFL7580A/27 52HFL5580D/27

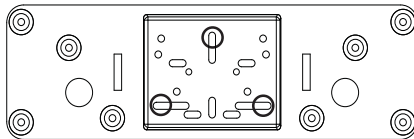

SCREWS SUPPLIED BY DISPLAY
MANUFACTURER

C. 26HFL5830D/27 32HFL5460D/27 32HFL5860D/27 32HFL7560D/27 32HF7965D/27 32HFL7965D/27

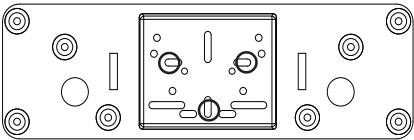

SCREWS SUPPLIED BY DISPLAY
MANUFACTURER

Attach lock-down plate to display base bottom using screws provided by manufacturer. Refer to lock-down plate/ display base stand hole pattern.

NOTE: Remove existing rubber feet from display base that interfere with the lock-down plate.

42HF7945D/27 HOLE PATTERN SHOWN

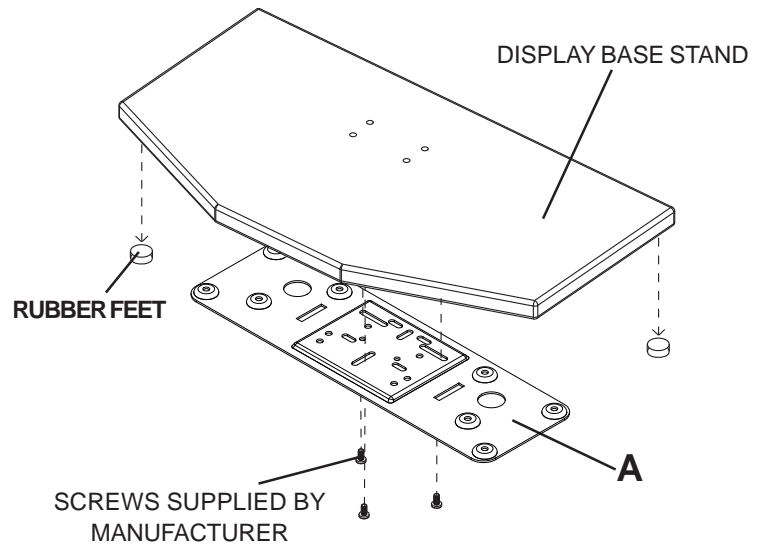

NOTE: Display base stand and mounting hole locations may appear different than illustrated.

- 4 Clean bottom of lock-down plate (A) with rubbing alcohol. Spray bottom of lock-down plate (A) only where tape will be applied, with 3M rubber and vinyl #80 spray adhesive. Pull apart the four adhesive strips (E) and remove red backing film on both sides. Wait at least 4 minutes to dry before applying adhesive strip (E). Attach adhesive strips (E) firmly to bottom of lock-down plate (A) as shown below.

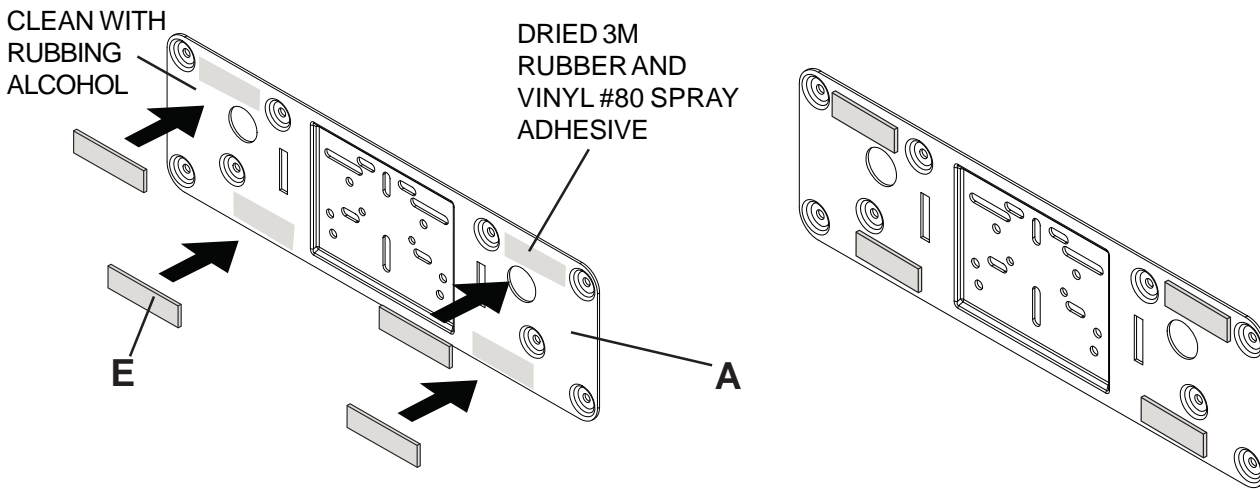

Clean desk surface with rubbing alcohol. Use 3M rubber and vinyl #80 spray adhesive (not supplied) on the **mounting surface area only**. **NOTE:** Spray adhesive **will not** remove easily. Wait at least 4 minutes to dry before removing tape backing from lock-down plate (A) and placing firmly on surface. **NOTE:** There is a recommended **72 hour cure time** for tape on lock-down plate (A).

NOTE: Once tape backing is removed be careful not to touch the sticky surface of the tape with fingers, as this can cause the tape to lose some of its holding power.

NOTE: After application of tape on lock-down plate (A), the bond strength will increase as the adhesive flows onto the surface.

At room temperature, approximately 50% of the ultimate strength will be achieved after 20 minutes, 90% after 24 hours, and 100% after 72 hours. In some cases, bond strength can be achieved more quickly by exposure to elevated temperatures (e.g. 150°F [66°C] for 1 hour).

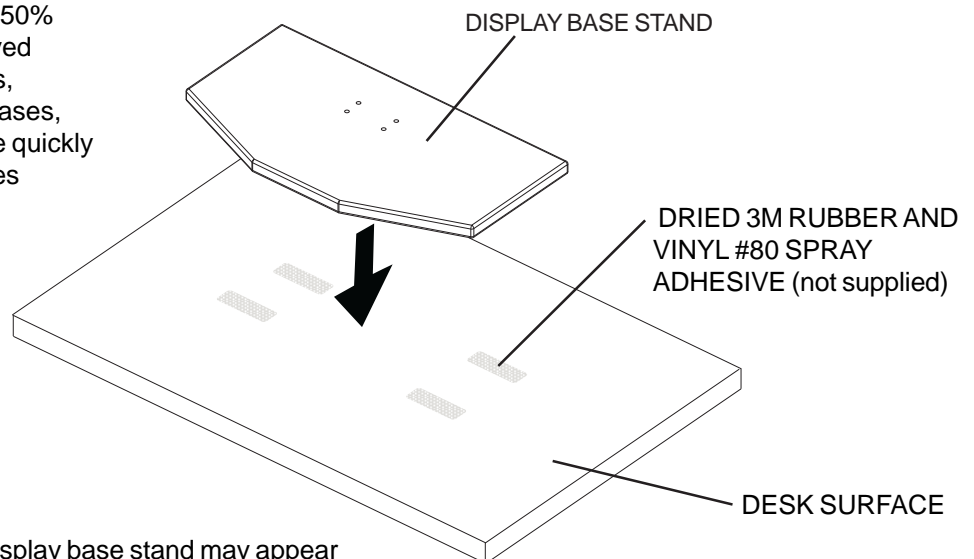

NOTE: Display base stand may appear different than illustrated.

Free Manuals Download Website

<http://myh66.com>

<http://usermanuals.us>

<http://www.somanuals.com>

<http://www.4manuals.cc>

<http://www.manual-lib.com>

<http://www.404manual.com>

<http://www.luxmanual.com>

<http://aubethermostatmanual.com>

Golf course search by state

<http://golfingnear.com>

Email search by domain

<http://emailbydomain.com>

Auto manuals search

<http://auto.somanuals.com>

TV manuals search

<http://tv.somanuals.com>