



DX8000-MUX16

Installation Manual

DX8000 Digital Video Recorder

C1601M (6/04)



Protecting people and property in a million locations worldwide.

Introduction

The following instructions serve as a guide for the installation of the DX8000-MUX16 analog output adapter.

PARTS LIST

Qty	Description
1	DX8000-MUX16 multiplexing analog output card
1	Adhesive-backed part label

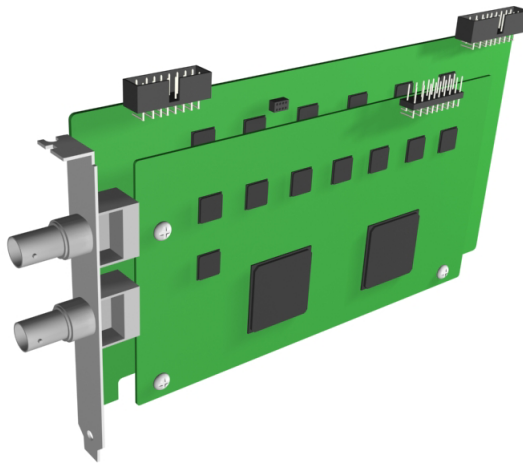

Figure 1. DX8000-MUX16 Analog Output Card

TOOLS NEEDED

- 1 Phillips-head screwdriver #1 (nonmagnetic)
- 1 Properly grounded ESD wrist strap and mat
- 4 Small containers for storing screws (optional)

Getting Ready

1. Familiarize yourself with the instructions throughout this manual.
2. Check that you have all the necessary parts and tools. Refer to the *Parts List* and *Tools Needed* sections.
3. Shut down the DX8000 Series DVR unit. Refer to DX8000 Installation Manual or Operations and Programming Manual for instructions on shutting down your unit.
4. Unplug the power cord from the wall socket and then from the rear of the DVR.



WARNING: For safety reasons, you must remove the power cord because current continues to flow through the DX8000 even when the unit is off. Remove the power cord from the wall socket first and then from the rear of the DVR. It is critical that the unit be unplugged for your safety.

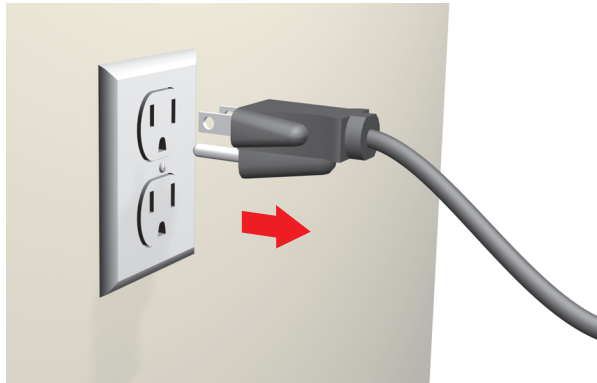

Figure 2. Removing Power Cord from Wall

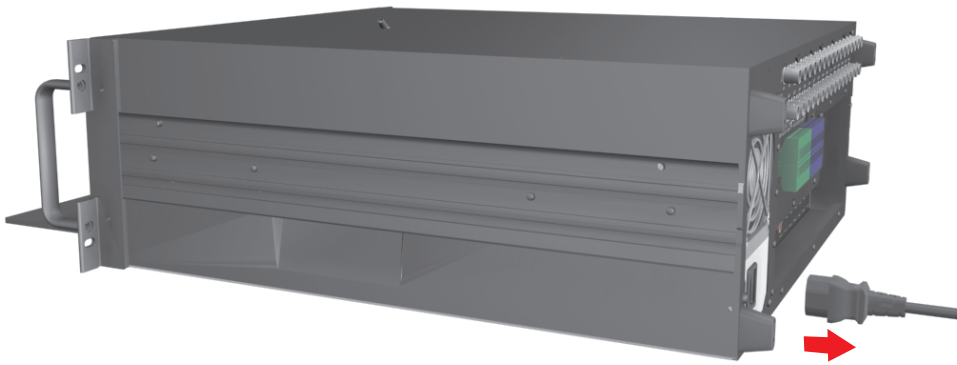

Figure 3. Removing Power Cord from Unit

5. Ensure that the DX8000 Series DVR and all of its components are protected against electro static discharge (ESD). Before handling any electronic components, you should take steps to properly ground yourself so that any built-up static electric charges are dissipated away from the unit. The most effective method for combating ESD is to use a properly grounded wrist strap.



NOTE: If you do not have access to a grounded wrist strap, you can discharge built-up static by periodically touching an unpainted section of the chassis.

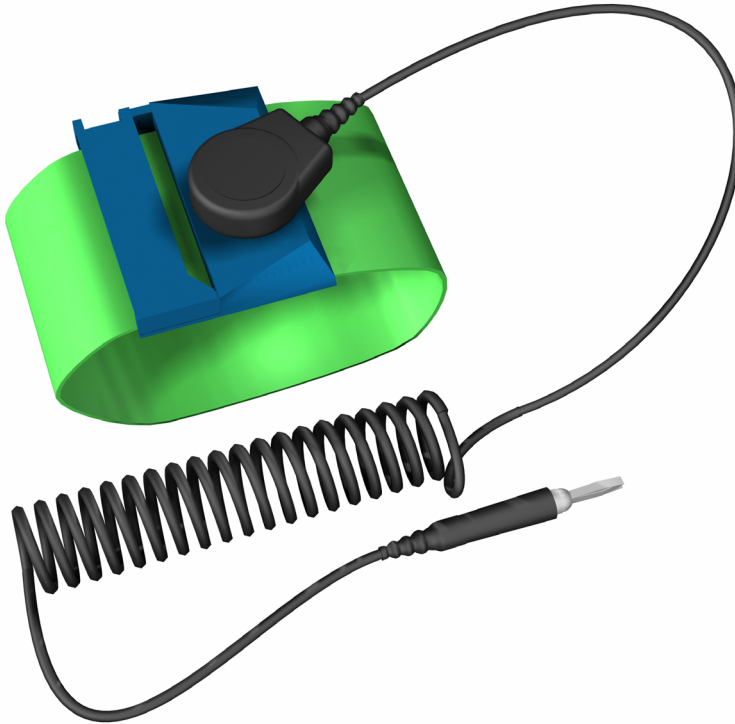

Figure 4. ESD Protection

Prepare the Unit

OPEN THE UNIT CHASSIS



WARNING: The chassis assembly includes parts with sharp edges. To avoid injury, use caution when working in and around the DX8000's chassis and components.

1. If the DX8000 is mounted in a rack, remove it and transport it to an area that will provide full access to the unit chassis:
 - a. Disconnect any cables or connections that might restrict access to or the removal of the unit.
 - b. Unscrew the fasteners that are securing the unit in the rack.
 - c. Carefully lift the unit out of the rack.



NOTE: Removing the DX8000 from a rack may require more than one person. Refer to the DX8000 Installation Manual for rack mounting information.

2. Place the DX8000 on a flat surface with ample workspace.

- Using a Phillips-head screwdriver, remove the chassis cover:



WARNING: Make sure unit is turned off and you are wearing a properly grounded ESD wrist strap before attempting to open the DX8000 chassis cover. Refer to the *Getting Ready* section.

- Remove the two top-most screws on the left and right side panels of the DX8000. Refer to Figure 5.
- Remove the four silver screws fastening the cover to the rear of the unit. These screws are the ones closest to the top of the unit. Refer to Figure 5.
- Carefully remove the chassis cover by sliding it back and up. Set aside the cover. Figure 6 illustrates the interior of the DX8000.

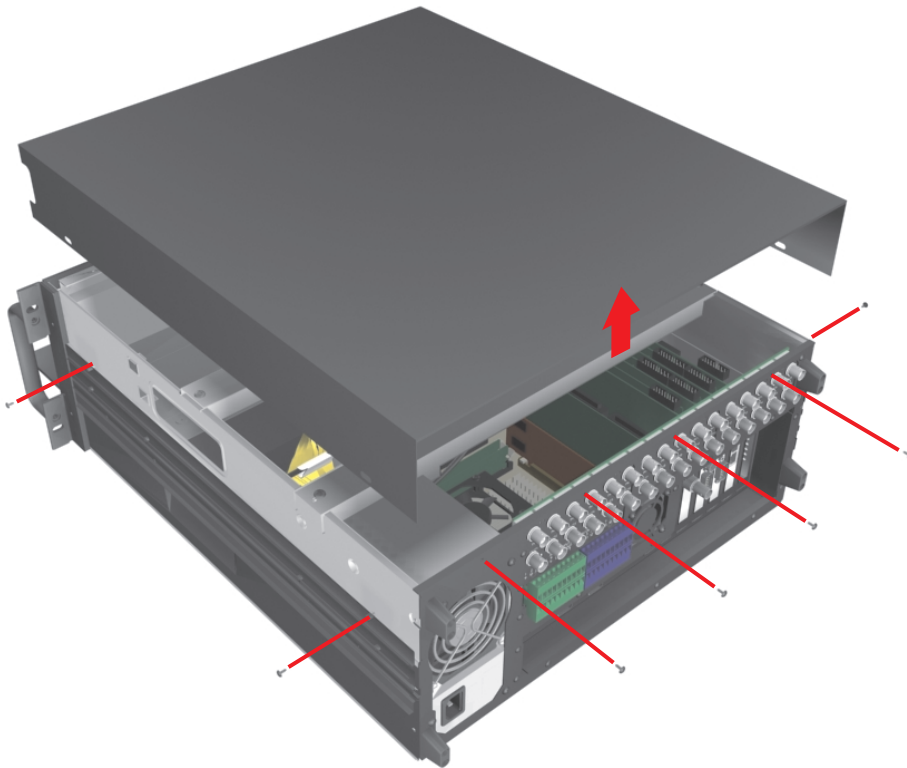

Figure 5. Removing Chassis Cover

COMPONENT LAYOUT

Figure 6 shows the location of your DX8000 Series DVR's major components. Certain cables and components have been omitted from the illustrations in this manual for the purpose of clarity.

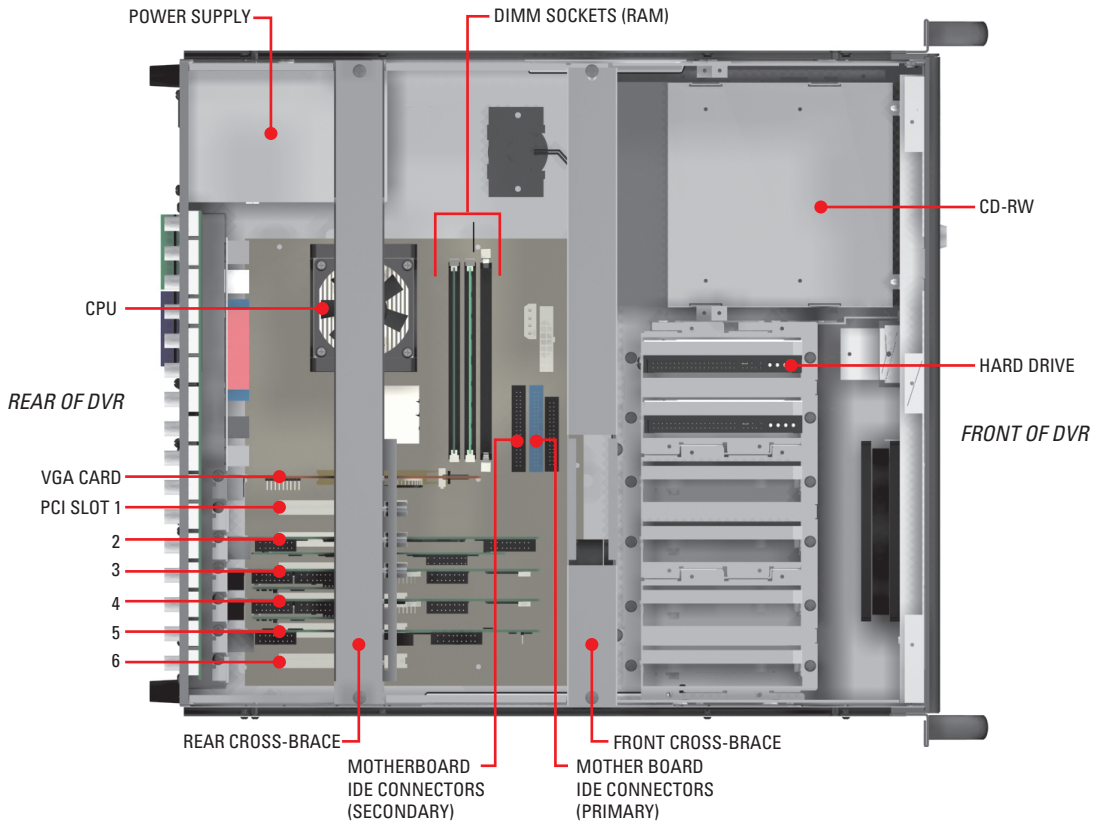

Figure 6. DX8000 Interior

REMOVE THE REAR CROSS-BRACE

1. Using a Phillips-head screwdriver, remove the two flat-head screws that secure the rear cross-brace. Refer to Figure 7.

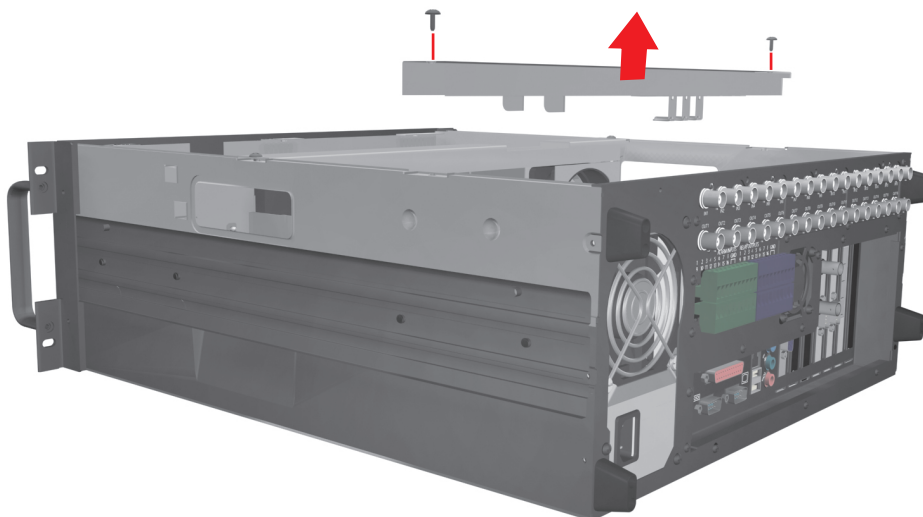

Figure 7. Removing Rear Cross-Brace

2. Move the rear cross-brace aside and keep the screws for later use.

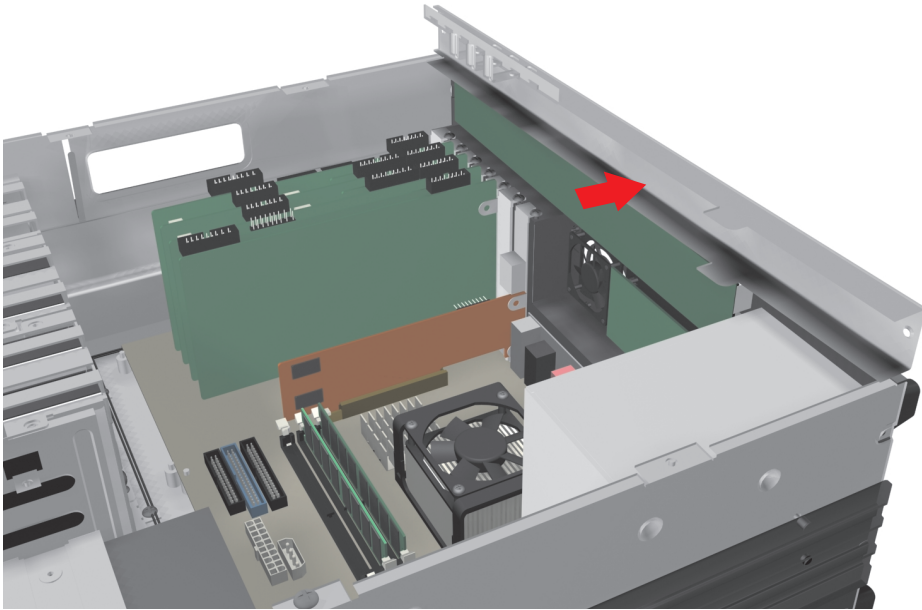
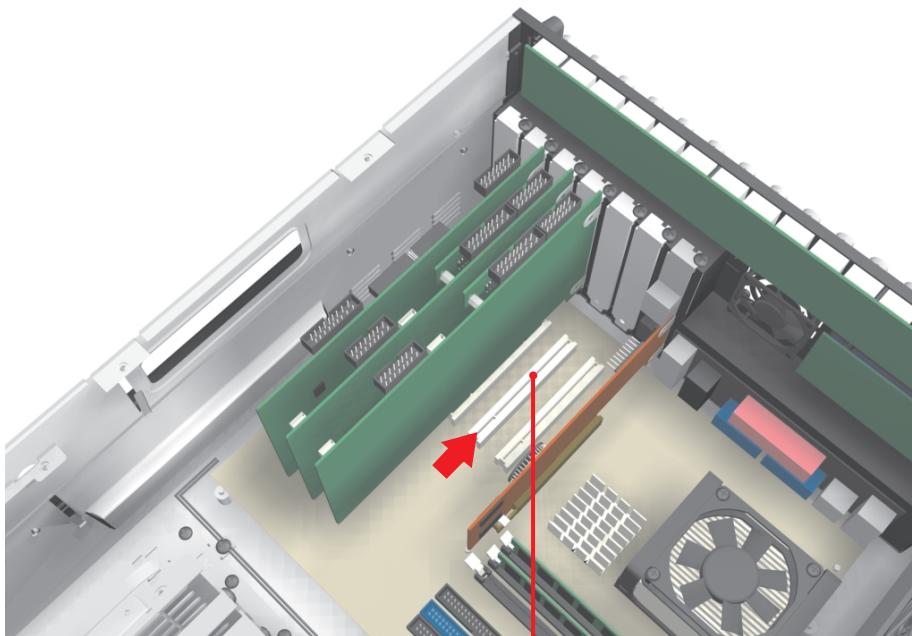

Figure 8. Moving Rear Cross-Brace to Rear of Unit

Install the DX8000-MUX16 Card

1. Locate PCI Slot 2 on the system motherboard. Refer to Figure 9.



PCI SLOT2

Figure 9. Location of PCI Slot 2

2. Remove the slot cover covering PCI Slot 2:
 - a. Using a Phillips-head screwdriver, remove the screw that fastens the slot cover to the chassis. Refer to Figure 10. Retain this screw for use in step 4d.
 - b. Remove the slot cover from PCI Slot 2.

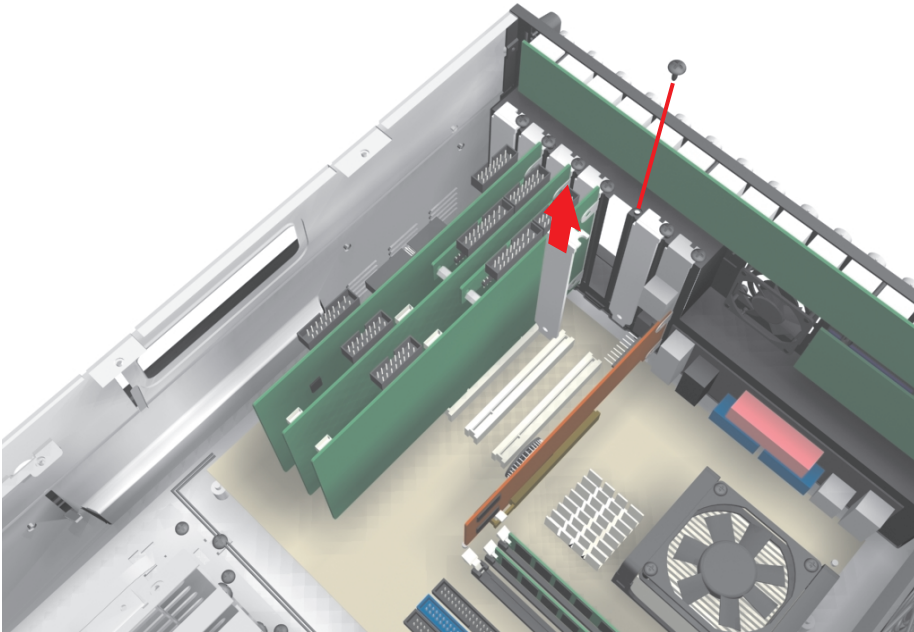

Figure 10. Slot Cover for PCI Slot 2

3. Carefully remove the DX8000-MUX16 card from its static-safe packaging. Handle the adapter card by its edges and slot cover, and avoid contact with the card's components, connectors, and conductive leads.
4. Insert the DX8000-MUX16 card in PCI Slot 2:
 - a. Carefully move aside any cables blocking access to PCI Slot 2.
 - b. Insert the DX8000-MUX16 card in the PCI slot. Refer to Figure 11.
 - c. Press down firmly to ensure that the card is fully seated into the PCI slot.



NOTE: Avoid using excessive force when inserting the card into the PCI slot. Attempting to force the card into the slot may damage the card, motherboard, and/or other components within the DX8000.

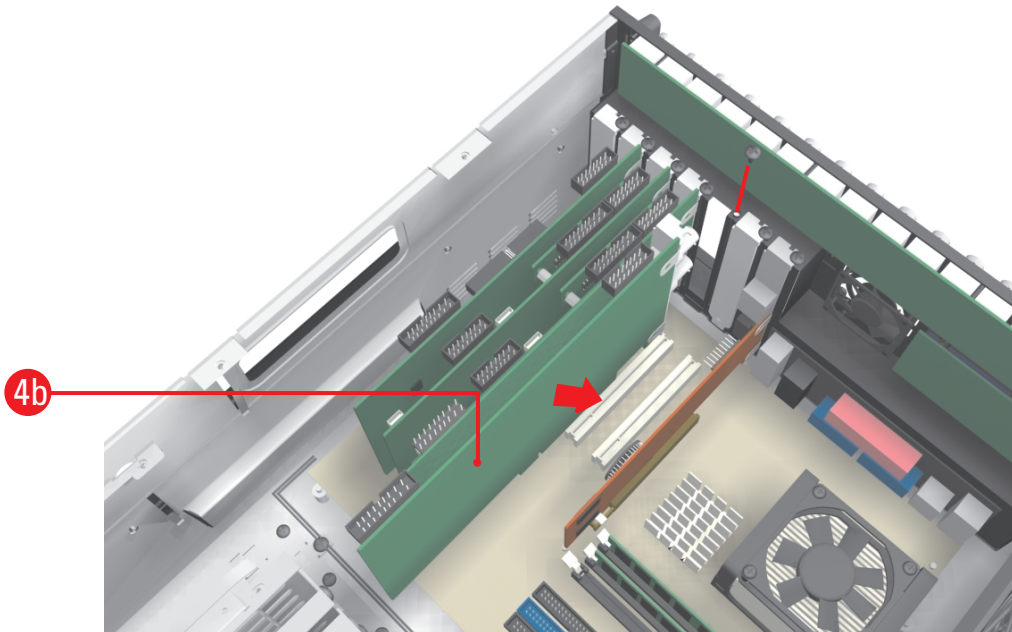

Figure 11. Inserting the DX8000-MUX16 Card into PCI Slot 2

- d. Using the screw you removed in step 2a, secure the DX8000-MUX16 card to the chassis. Refer to Figure 12.

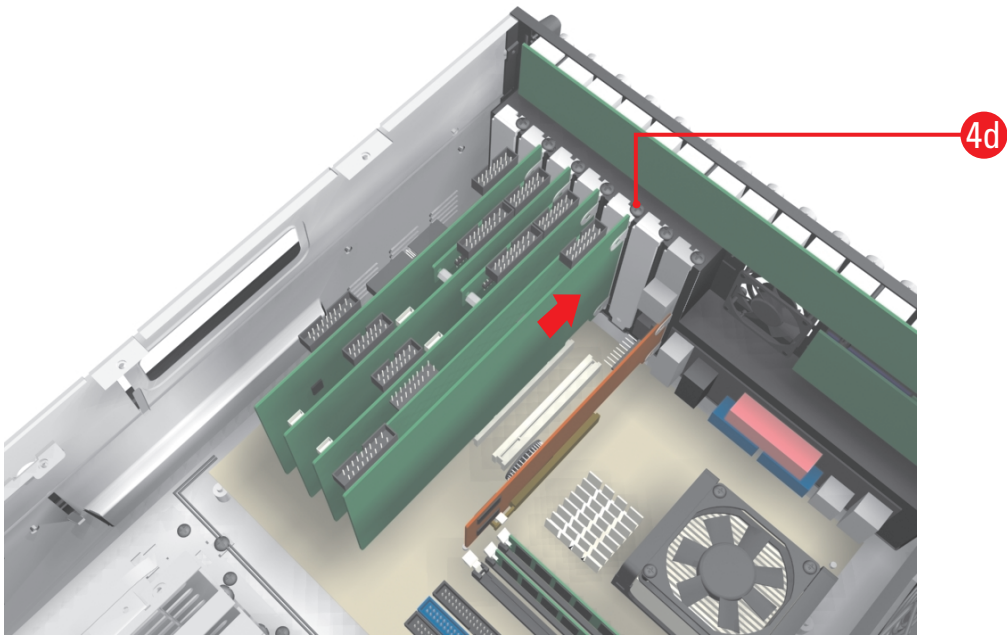

Figure 12. Securing the DX8000-MUX16 Card

5. Connect video data cables:
 - a. Connect the rear video input ribbon cable from the primary capture card to the DX8000-MUX16 card. Refer to Figure 13.

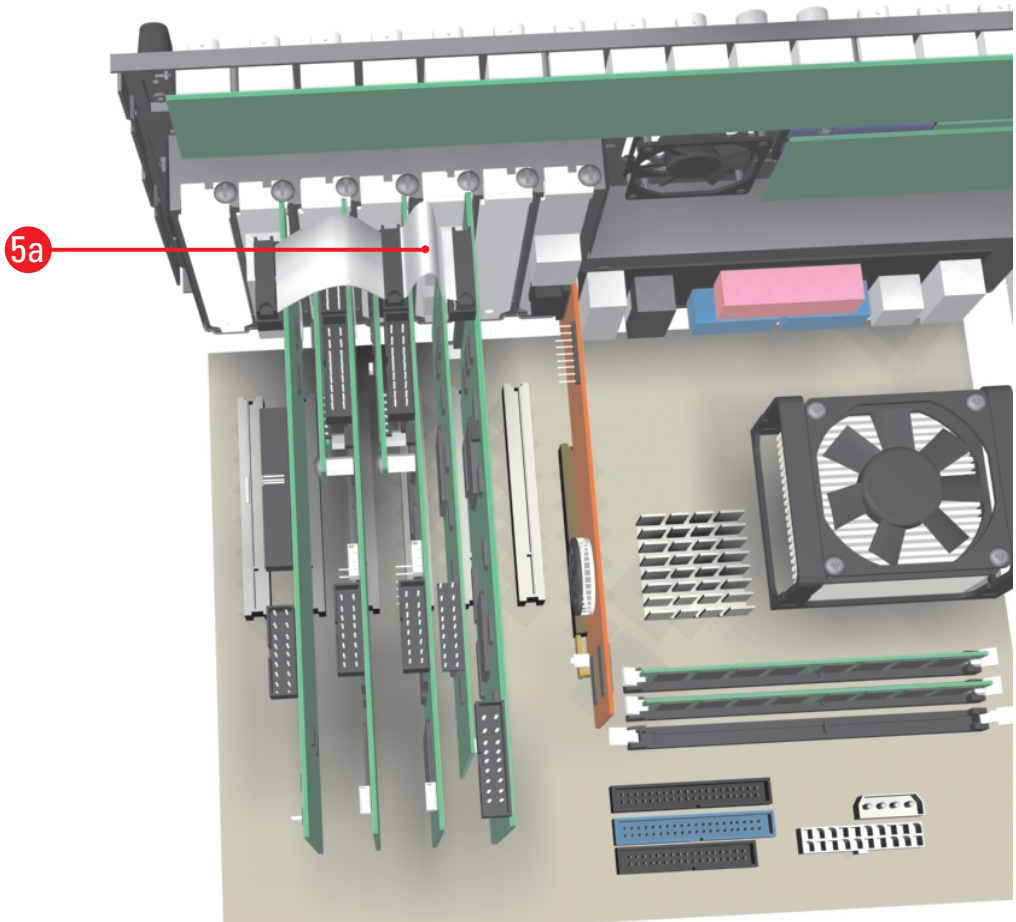

Figure 13. Primary Capture Card Video Input Cable

- b. Connect the front video input ribbon cable from the secondary capture card to the connector on the daughter board of the DX8000-MUX16. Refer to Figure 14.

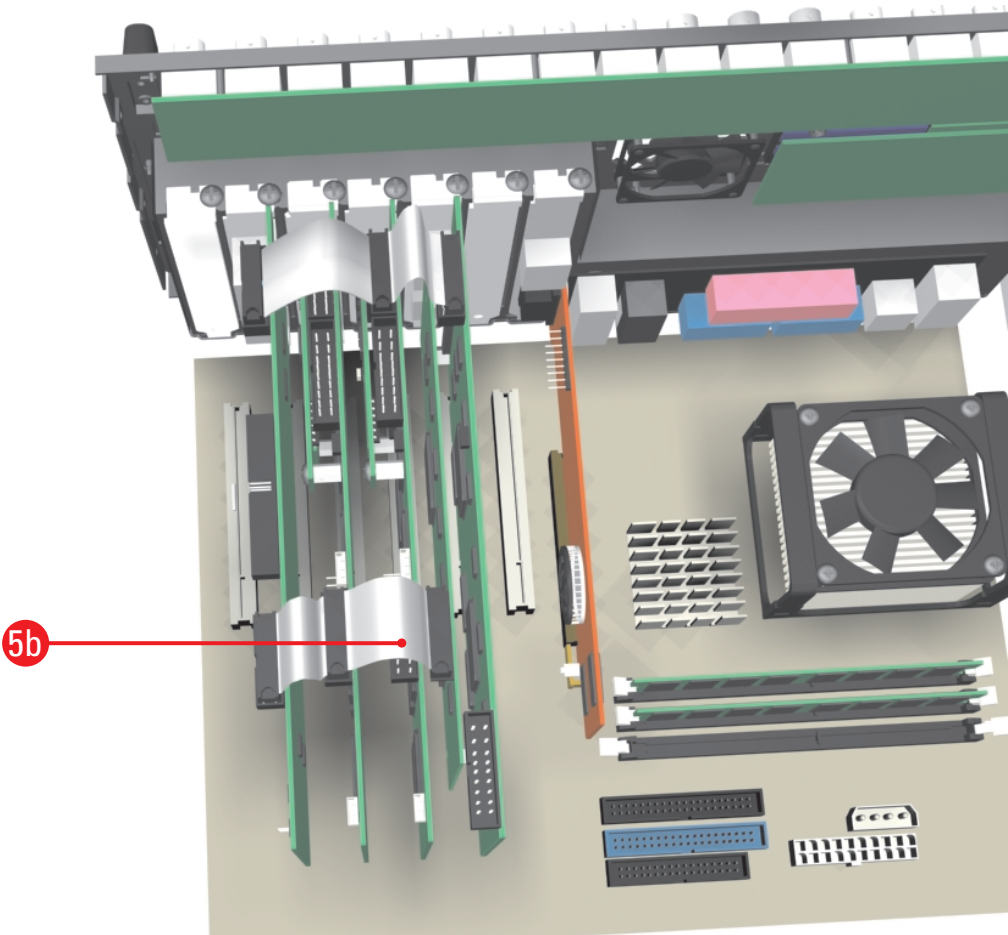

Figure 14. Secondary Capture Card Video Input Cable

- c. Connect the video output ribbon cable from the DX8000-MUX16 card to the VGA card. Refer to Figure 15.

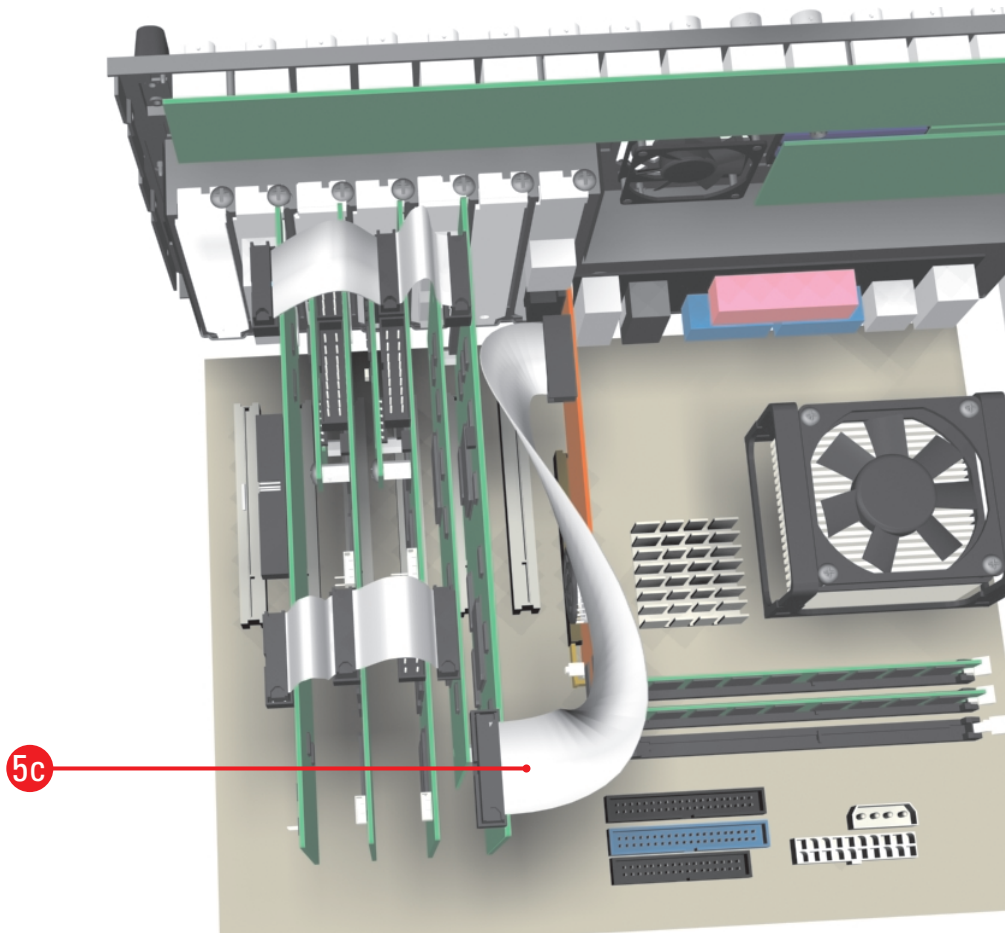

Figure 15. Video Data Cable Connections

Reassemble the Unit

1. Replace the rear cross-brace and secure it with the flat-head screws you set aside earlier. Refer to Figure 16.

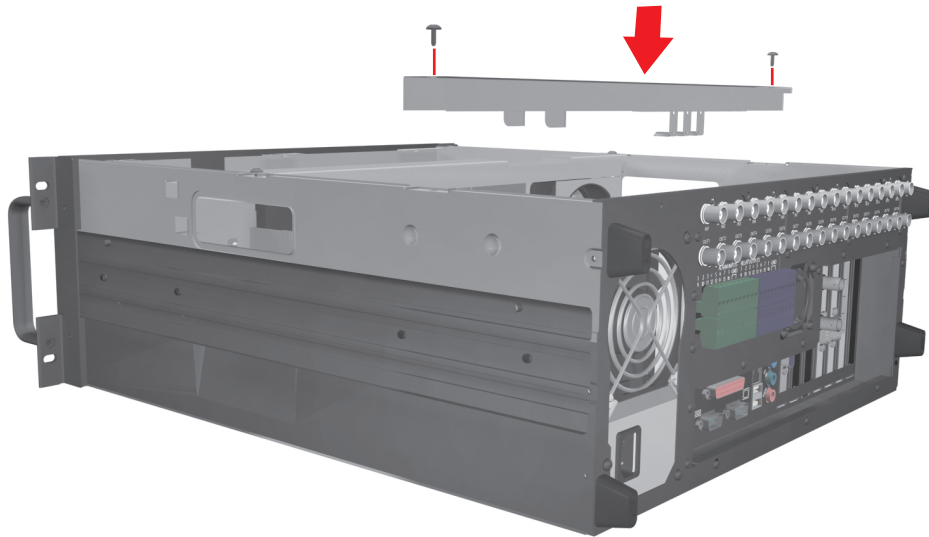

Figure 16. Replacing Front Cross-Brace

2. Replace the chassis cover using the same screws you removed from the side and rear of the unit. Refer to Figure 17.

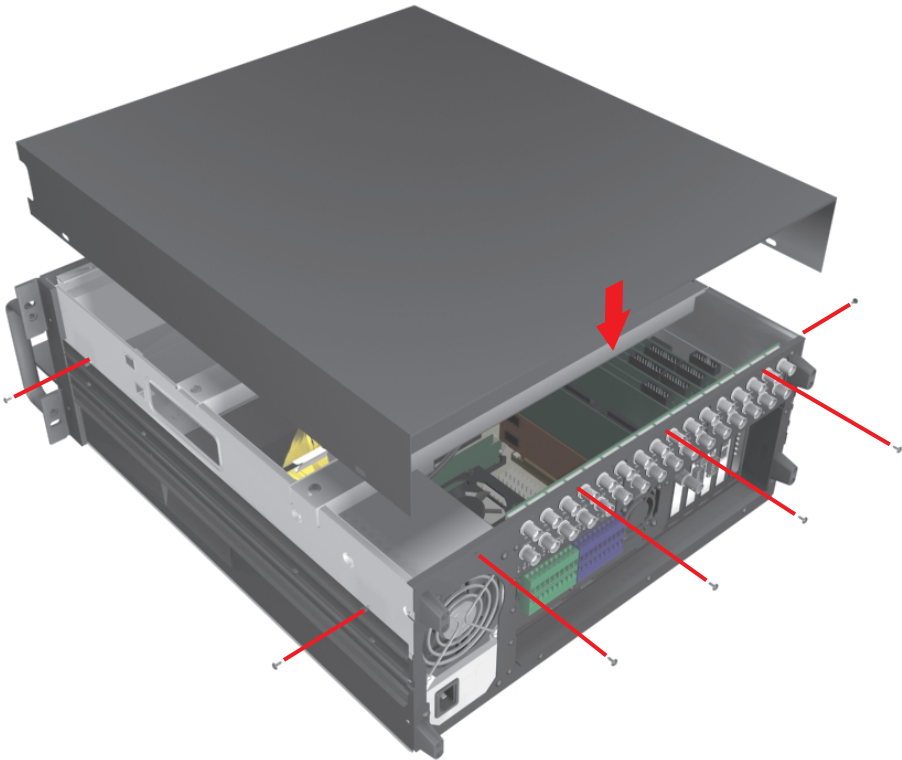

Figure 17. Replacing Chassis Cover

3. Attach the silver part label that came in your upgrade kit to the inside of your DVR's front door.
 - a. Remove the paper backing from the part label.
 - b. Carefully place the label, adhesive-side down, on a free section of the inside of the door.
 - c. Press down firmly to ensure that the label properly adheres to the inside of the door.



NOTE: In the event that your unit or its components require service, part labels must be present and appropriately affixed to the unit's door. Pelco product support personnel use these labels to identify the exact components installed in your system. A separate part label is required for each upgrade component installed on the DX8000.



Figure 18. Product Label

4. Reinstall the unit in a rack enclosure if necessary, and reconnect all cables and peripheral equipment that you removed earlier.
5. Plug the power cord back into the power supply and then into the wall.
6. Turn on the power switch and allow the unit to start up and find the new hardware. This may take several minutes.

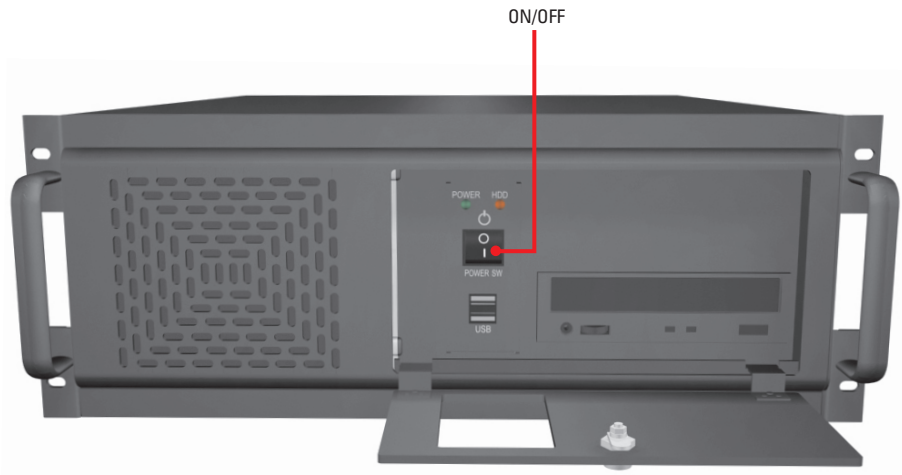

Figure 19. Restarting the Unit

PRODUCT WARRANTY AND RETURN INFORMATION

WARRANTY

Pelco will repair or replace, without charge, any merchandise proved defective in material or workmanship for a period of one year after the date of shipment.

Exceptions to this warranty are as noted below:

- Five years on the following fixed camera models: CC3701H-2, CC3701H-2X, CC3751H-2, CC3651H-2X, MC3651H-2, and MC3651H-2X.
- Three years on all other fixed camera models (including Camclosure® Integrated Camera Systems) and Genex® Series (multiplexers, server, and keyboard).
- Two years on all standard motorized or fixed focal length lenses.
- Two years on Legacy®, CM6700/CM6800/CM8500/CM9500/CM9700 Series Matrix, DF5 and DF8 Series Fixed Dome products.
- Two years on Spectra®, Esprit®, and PS20 Scanners, including when used in continuous motion applications.
- Two years on Esprit® and WW5700 series window wiper (excluding wiper blades).
- Eighteen months on DX Series digital video recorders and NVR300 network video recorders.
- One year (except video heads) on video cassette recorders (VCRs). Video heads will be covered for a period of six months.
- Six months on all pan and tilts, scanners or preset lenses used in continuous motion applications (that is, preset scan, tour and auto scan modes).

Pelco will warrant all replacement parts and repairs for 90 days from the date of Pelco shipment. All goods requiring warranty repair shall be sent freight prepaid to Pelco, Clovis, California. Repairs made necessary by reason of misuse, alteration, normal wear, or accident are not covered under this warranty.

Pelco assumes no risk and shall be subject to no liability for damages or loss resulting from the specific use or application made of the Products. Pelco's liability for any claim, whether based on breach of contract, negligence, infringement of any rights of any party or product liability, relating to the Products shall not exceed the price paid by the Dealer to Pelco for such Products. In no event will Pelco be liable for any special, incidental or consequential damages (including loss of use, loss of profit and claims of third parties) however caused, whether by the negligence of Pelco or otherwise.

The above warranty provides the Dealer with specific legal rights. The Dealer may also have additional rights, which are subject to variation from state to state.

If a warranty repair is required, the Dealer must contact Pelco at (800) 289-9100 or (559) 292-1981 to obtain a Repair Authorization number (RA), and provide the following information:

1. Model and serial number
2. Date of shipment, P.O. number, Sales Order number, or Pelco invoice number
3. Details of the defect or problem

If there is a dispute regarding the warranty of a product which does not fall under the warranty conditions stated above, please include a written explanation with the product when returned.

Method of return shipment shall be the same or equal to the method by which the item was received by Pelco.

RETURNS

In order to expedite parts returned to the factory for repair or credit, please call the factory at (800) 289-9100 or (559) 292-1981 to obtain an authorization number (CA number if returned for credit, and RA number if returned for repair).

All merchandise returned for credit may be subject to a 20% restocking and refurbishing charge.

Goods returned for repair or credit should be clearly identified with the assigned CA or RA number and freight should be prepaid. Ship to the appropriate address below.

If you are located within the continental U.S., Alaska, Hawaii or Puerto Rico, send goods to:

Service Department
Pelco
3500 Pelco Way
Clovis, CA 93612-5699

If you are located outside the continental U.S., Alaska, Hawaii or Puerto Rico and are instructed to return goods to the USA, you may do one of the following:

If the goods are to be sent by a COURIER SERVICE, send the goods to:

Pelco
3500 Pelco Way
Clovis, CA 93612-5699 USA

If the goods are to be sent by a FREIGHT FORWARDER, send the goods to:

Pelco c/o Expeditors
473 Eccles Avenue
South San Francisco, CA 94080 USA
Phone: 650-737-1700
Fax: 650-737-0933

© Pelco, the Pelco logo, Spectra, Genex, Legacy, Coaxitron, Esprit and Camclosure are registered trademarks of Pelco.
™ Spectra II and Spectra III are trademarks of Pelco.
© Copyright 2004, Pelco. All rights reserved.



Worldwide Headquarters
3500 Pelco Way
Clovis, California 93612 USA

USA & Canada
Tel: 800/289-9100
Fax: 800/289-9150

International
Tel: 1-559/292-1981
Fax: 1-559/348-1120

www.pelco.com

ISO9001

United States | Canada | United Kingdom | The Netherlands | Singapore | Spain | Scandinavia | France | Middle East

Free Manuals Download Website

<http://myh66.com>

<http://usermanuals.us>

<http://www.somanuals.com>

<http://www.4manuals.cc>

<http://www.manual-lib.com>

<http://www.404manual.com>

<http://www.luxmanual.com>

<http://aubethermostatmanual.com>

Golf course search by state

<http://golfingnear.com>

Email search by domain

<http://emailbydomain.com>

Auto manuals search

<http://auto.somanuals.com>

TV manuals search

<http://tv.somanuals.com>