



by **Schneider** Electric

INSTALLATION

IS150 Series Camclosure®



Integrated Camera System

C3427M-D (2/09)

Contents

Regulatory Notices	5
Description	6
Models	6
Parts List	7
Cover and Back Box Installation	9
Unshielded Twisted Pair (UTP) Video	9
Fixed Ceiling/Wall	9
Suspended Ceiling	10
4S Deep Electrical Box	11
Camera Module	12
Module Removal	12
Camera Orientation	14
Module Installation	14
Camera Adjustments	15
Varifocal Lens Zoom and Focus Adjustments	15
DN/CH Series Adjustments	17
Switch Settings	17
Auto Iris Level Adjustment	18
Vertical Phase Adjustment	19
Blemish Detection	19
Day/Night Operation	20
DW/CW Series (Wide Dynamic Range) Adjustments	21
Switch Settings	21
Auto Iris Level Adjustment	24
Vertical Phase Adjustment	24
Blemish Detection	24
Camera Positioning	25
Install Liner and Trim Ring	26
Service Connector	27
Specifications	29

List of Illustrations

1	Package Components	8
2	Ceiling/Wall Installation	9
3	Ceiling Tile Installation	10
4	4S Deep Electrical Box Installation	11
5	Camera Module Bracket	12
6	Back Box Connectors	13
7	Camera Orientation	14
8	Location of Zoom and Focus Locking Screws	15
9	Adjusting the Focus	16
10	Adjusting the IS150-DN/CH Series Camclosure	17
11	DN Models Threshold Switching Levels	20
12	Adjusting the IS150-DW/CW Series Camclosure	21
13	DW Models Threshold Switching Levels	23
14	Positioning the Camera	25
15	Adjusting the Liner	26
16	Service Connector	27
17	Attaching the 2.5 mm Monaural Headphone Plug	28

List of Tables

A	IS150, Smoked Bubble Without Liner	6
B	IS151, Clear Bubble with Liner	7
C	Power Input: Fixed Ceiling/Wall Installation	9
D	Power Input: Suspended Installation	10
E	Power Input: 4S Deep Electrical Box Installation	11
F	DN Models Switching Thresholds	20
G	DW Models Switching Thresholds	23

Regulatory Notices

This device complies with Part 15 of the FCC Rules. Operation is subject to the following two conditions: (1) this device may not cause harmful interference, and (2) this device must accept any interference received, including interference that may cause undesired operation.

RADIO AND TELEVISION INTERFERENCE

This equipment has been tested and found to comply with the limits of a Class B digital device, pursuant to part 15 of the FCC rules. These limits are designed to provide reasonable protection against harmful interference in a residential installation. This equipment generates, uses, and can radiate radio frequency energy and, if not installed and used in accordance with the instructions, may cause harmful interference to radio communications. However there is no guarantee that the interference will not occur in a particular installation. If this equipment does cause harmful interference to radio or television reception, which can be determined by turning the equipment off and on, the user is encouraged to try to correct the interference by one or more of the following measures:

- Reorient or relocate the receiving antenna.
- Increase the separation between the equipment and the receiver.
- Connect the equipment into an outlet on a circuit different from that to which the receiver is connected.
- Consult the dealer or an experienced radio/TV technician for help.

You may also find helpful the following booklet, prepared by the FCC: "How to Identify and Resolve Radio-TV Interference Problems." This booklet is available from the U.S. Government Printing Office, Washington D.C. 20402.

Changes and Modifications not expressly approved by the manufacturer or registrant of this equipment can void your authority to operate this equipment under Federal Communications Commission's rules.

This Class B digital apparatus complies with Canadian ICES-003.

Cet appareil numérique de la classe B est conforme à la norme NMB-003 du Canada.



WARNING: This product is sensitive to Electrostatic Discharge (ESD). To avoid ESD damage to this product, use ESD safe practices during installation. Before touching, adjusting or handling this product, correctly attach an ESD wrist strap to your wrist and appropriately discharge your body and tools. For more information about ESD control and safe handling practices of electronics, please refer to ANSI/ESD S20.20-1999 or contact the Electrostatic Discharge Association (www.esda.org).



The materials used in the manufacture of this document and its components are compliant to the requirements of Directive 2002/95/EC.



This equipment contains electrical or electronic components that must be recycled properly to comply with Directive 2002/96/EC of the European Union regarding the disposal of waste electrical and electronic equipment (WEEE). Contact your local dealer for procedures for recycling this equipment.

Description

The IS150 Series Camclosure® integrated camera system combines an environmental cover, back box, camera, lens, and lower dome into a small, high-security system that is quick and easy to install. The system is perfect for a variety of indoor and outdoor applications and its versatile design allows for multiple mounting options. The unit supports both BNC and unshielded twisted pair (UTP) video wiring. The IS150 Series Camclosure integrated camera system can be installed directly into a ceiling, wall, or 4S deep electrical box.

Before installing your new system, thoroughly familiarize yourself with the information in this manual.

MODELS

The IS150 models include the following specifications: Indoor/outdoor dome, vandal resistant, in-ceiling mount, smoked bubble, gray finish.

Table A. IS150, Smoked Bubble Without Liner

Camera Type	Lens/Iris	NTSC	PAL
Color, Wide Dynamic Range, Day/Night	3.0 to 9.5 mm, Day/Night Varifocal, Auto Iris	IS150-DWV9	—
	9.0 to 22.0 mm, Day/Night Varifocal, Auto Iris	IS150-DWV22	—
Color, High Resolution, Day/Night	3.0 to 9.5 mm, Day/Night Varifocal, Auto Iris	IS150-DNV9	IS150-DNV9X
	9.0 to 22.0 mm, Day/Night Varifocal, Auto Iris	IS150-DNV22	IS150-DNV22X
Color, Wide Dynamic Range	3.0 to 9.5 mm, Varifocal, Auto Iris	IS150-CWV9	—
	9.0 to 22.0 mm, Day/Night Varifocal, Auto Iris	IS150-CWV22	—
Color, High Resolution	3.0 to 9.5 mm, Varifocal, Auto Iris	IS150-CHV9	IS150-CHV9X
	9.0 to 22.0 mm, Varifocal, Auto Iris	IS150-CHV22	IS150-CHV22X
	3.0 mm, Fixed, Manual Iris	IS150-CH3	IS150-CH3X
	3.6 mm, Fixed, Manual Iris	IS150-CH3.6	IS150-CH3.6X
	6.0 mm, Fixed, Manual Iris	IS150-CH6	IS150-CH6X
	8.0 mm, Fixed, Manual Iris	IS150-CH8	IS150-CH8X
	12.0 mm, Fixed, Manual Iris	IS150-CH12	IS150-CH12X

Indoor/outdoor dome, vandal resistant, in-ceiling mount, clear bubble, liner, gray finish

Table B. IS151, Clear Bubble with Liner

Camera Type	Lens/Iris	NTSC	PAL
Color, Wide Dynamic Range, Day/Night	3.0 to 9.5 mm, Day/Night Varifocal, Auto Iris	IS151-DWV9	—
	9.0 to 22 mm, Day/Night Varifocal, Auto Iris	IS151-DWV22	—
Color, High Resolution, Day/Night	3.0 to 9.5 mm, Day/Night Varifocal, Auto Iris	IS151-DNV9	IS151-DNV9X
	9.0 to 22.0 mm, Day/Night Varifocal, Auto Iris	IS151-DNV22	IS151-DNV22X
Color, Wide Dynamic Range	3.0 to 9.5 mm, Varifocal, Auto Iris	IS151-CWV9	—
	9.0 to 22.0 mm, Day/Night Varifocal, Auto Iris	IS151-CWV22	—
Color, High Resolution	3.0 to 9.5 mm, Varifocal, Auto Iris	IS151-CHV9	IS151-CHV9X
	9.0 to 22.0 mm, Varifocal, Auto Iris	IS151-CHV22	IS151-CHV22X
	3.0 mm, Fixed, Manual Iris	IS151-CH3	IS151-CH3X
	3.6 mm, Fixed, Manual Iris	IS151-CH3.6	IS151-CH3.6X
	6.0 mm, Fixed, Manual Iris	IS151-CH6	IS151-CH6X
	8.0 mm, Fixed, Manual Iris	IS151-CH8	IS151-CH8X
	12.0 mm, Fixed, Manual Iris	IS151-CH12	IS151-CH12X

PARTS LIST

Qty Description

- 1 IS150 Series Camclosure integrated camera system
 - Back box
 - Trim ring with bubble; clear bubble models include a liner
 - Camera module
- 1 Adapter plate
- 1 1/8-inch hollow screwdriver bit
- 4 Screws, 8-32 x 0.375-inch, Phillips flat head
- 2 Screws, 8-32 x 0.75-inch, Phillips flat head
- 4 Screws, 8-32 x 1.25-inch, Phillips flat head

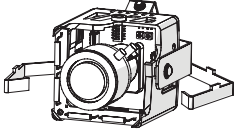

CAMERA MODULE
1 EA.

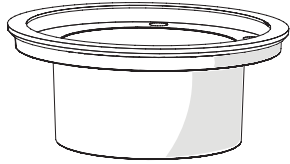

BACK BOX
1 EA.

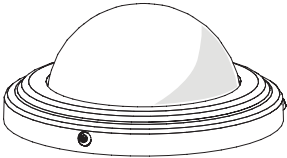

TRIM RING AND
SMOKED BUBBLE
1 EA.

< OR >

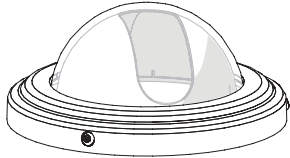

TRIM RING, LINER,
AND CLEAR BUBBLE
1 EA.



ADAPTER PLATE
1 EA.

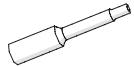

1/8-INCH HOLLOW
SCREWDRIVER BIT
1 EA.

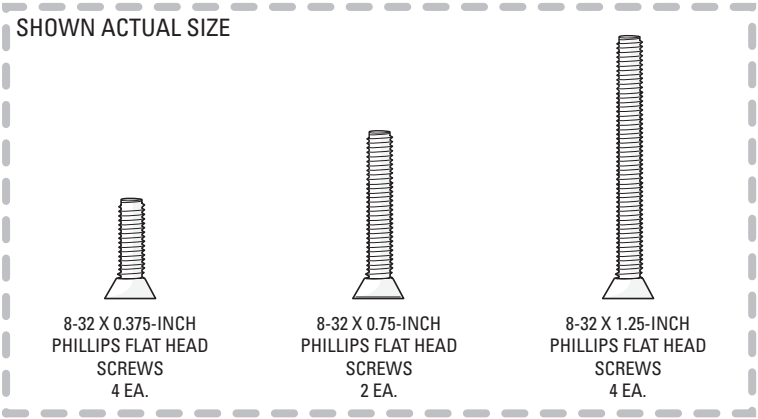

8-32 X 0.375-INCH
PHILLIPS FLAT HEAD
SCREWS
4 EA.

8-32 X 0.75-INCH
PHILLIPS FLAT HEAD
SCREWS
2 EA.

8-32 X 1.25-INCH
PHILLIPS FLAT HEAD
SCREWS
4 EA.

Figure 1. Package Components

Cover and Back Box Installation

The IS150 Series Camclosure integrated camera system mounts only into a wall or ceiling.

UNSHIELDED TWISTED PAIR (UTP) VIDEO

The IS150 Series offers support for unshielded twisted pair (UTP). The UTP video output signal is 1 Vp-p differential into a 100-ohm load. At a minimum, UTP requires Cat5, 100-ohm twisted pair cable.

FIXED CEILING/WALL

NOTE: You should install the camera module into the back box before installing the back box into the surface. When installing the back box into the surface, rotate the camera module to access the mounting holes (refer to *Camera Module* on page 12 for more information).

1. Cut a hole 3.5 inches (9 cm) in diameter in the ceiling or wall. Use the adapter plate (supplied) as a template.
2. Pull the video and power wires through the ceiling or wall.
3. Connect the video cable and wires:
 - **BNC:** Connect the BNC connector from the unit to a mating BNC connector.
 - **UTP:** Connect the blue wire to Video +; connect the gray wire to Video -.
4. Connect the power wires (refer to Table C).

Table C. Power Input: Fixed Ceiling/Wall Installation

Voltage	Red Wire	Black Wire
12 VDC	+	Ground
24 VAC	~	~

AC operation only: If you are wiring more than one Camclosure to the same transformer, connect one side of the transformer to the red wire on all units; connect the other side of the transformer to the black wire on all units.

NOTE: Failure to connect all AC powered units the same way will cause the cameras to be out of phase with each other, which may produce a vertical roll when switching between cameras.

5. For a nonconcrete ceiling/wall, use 6-32 toggle bolts to attach the surface mount ring and back box to the mounting surface. For a concrete ceiling/wall, use 8-32 mounting hardware. Mounting hardware is not supplied.

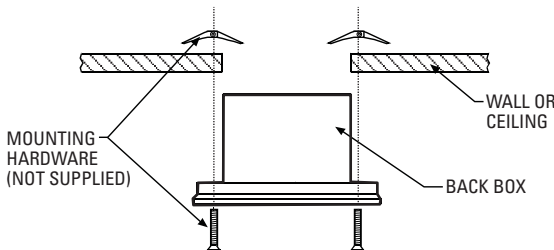

Figure 2. Ceiling/Wall Installation

SUSPENDED CEILING

NOTE: You should install the camera module into the back box before installing the back box into the surface. When installing the back box into the surface, rotate the camera module to access the mounting holes (refer to *Camera Module* on page 12 for more information).

1. Pull the video and power wires to the ceiling tile.
2. Mount the unit to the ceiling tile (refer to Figure 3):
 - a. Remove the ceiling tile from the ceiling.
 - b. Cut a hole 3.5 inches (9 cm) in diameter in the ceiling tile. Use the adapter plate (supplied) as a template. Punch four screw holes in the ceiling tile.
 - c. Attach the back box to the ceiling tile and adapter plate with four 8-32 x 1.25-inch Phillips flat head screws (supplied).
 - d. Reinstall the ceiling tile with the unit.

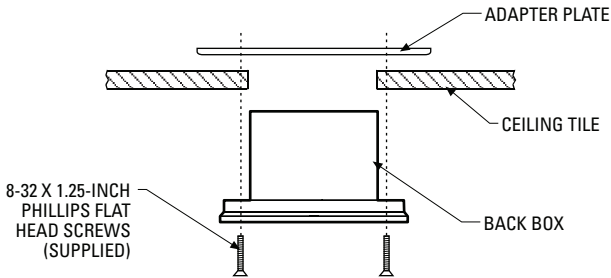

Figure 3. Ceiling Tile Installation

3. Remove an adjacent ceiling tile.
4. Connect the video cable and wires:
 - **BNC:** Connect the BNC connector from the unit to a mating BNC connector.
 - **UTP:** Connect the blue wire to Video +; connect the gray wire to Video -.
5. Connect the power wires (refer to Table D).

Table D. Power Input: Suspended Installation

Voltage	Red Wire	Black Wire
12 VDC	+	Ground
24 VAC	~	~

AC operation only: If you are wiring more than one Camclosure to the same transformer, connect one side of the transformer to the red wire on all units; connect the other side of the transformer to the black wire on all units.

NOTE: Failure to connect all AC powered units the same way will cause the cameras to be out of phase with each other, which may produce a vertical roll when switching between cameras.

4S DEEP ELECTRICAL BOX

NOTE: You should install the camera module into the back box before installing the back box into the surface. When installing the back box into the surface, rotate the camera module to access the mounting holes (refer to *Camera Module* on page 12 for more information).

1. Attach the supplied adapter plate to the 4S box with two 8-32 x 0.75-inch Phillips flat head screws (supplied).
2. Pull the video and power wires to the ceiling tile.
3. Connect the video cable and wires:
 - **BNC:** Connect the BNC connector from the unit to a mating BNC connector.
 - **UTP:** Connect the blue wire to Video +; connect the gray wire to Video -.
4. Connect the power wires (refer to Table E).

Table E. Power Input: 4S Deep Electrical Box Installation

Voltage	Red Wire	Black Wire
12 VDC	+	Ground
24 VAC	~	~

AC operation only: If you are wiring more than one Camclosure to the same transformer, connect one side of the transformer to the red wire on all units; connect the other side of the transformer to the black wire on all units.

NOTE: Failure to connect all AC powered units the same way will cause the cameras to be out of phase with each other, which may produce a vertical roll when switching between cameras.

5. Attach the back box to the adapter plate with four 8-32 x 0.375-inch Phillips flat head screws (supplied).

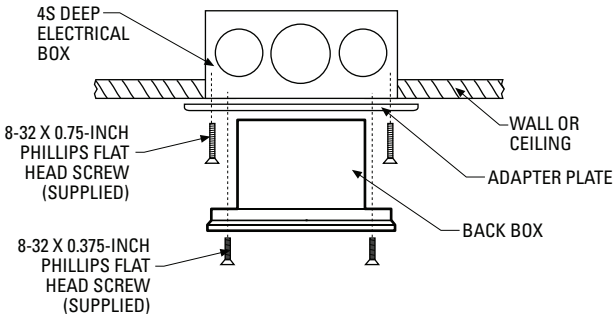

Figure 4. 4S Deep Electrical Box Installation

Camera Module

The IS150 Series Camclosure camera module includes the camera, camera bracket, and heater board. To perform most camera adjustments, you must remove the module from the back box.

Use the following instructions to remove and reinstall the camera module.

! **WARNING:** Heater elements could be hot! When camera power is on, use caution when adjusting the camera. This applies to all models.

MODULE REMOVAL

To remove the camera module from the back box:

1. Gently squeeze the bracket and pull the module out of the back box (refer to Figure 5).

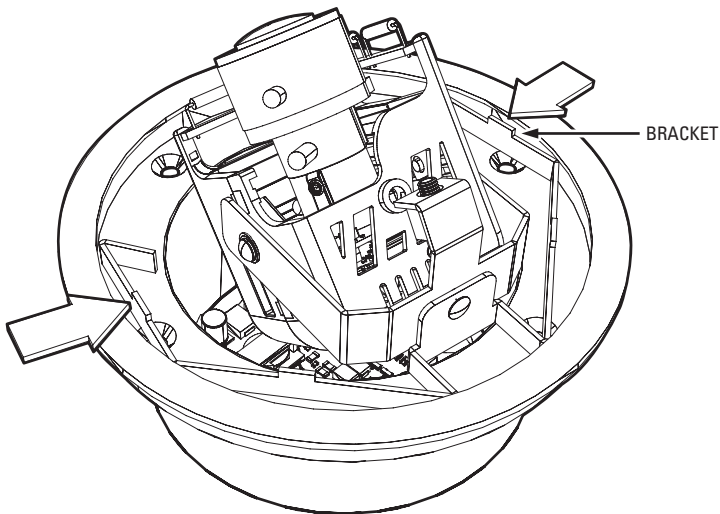

Figure 5. Camera Module Bracket

2. Unplug the camera (10-pin), service (3-pin), and heater board (4-pin) connectors from the back box (refer to Figure 6).

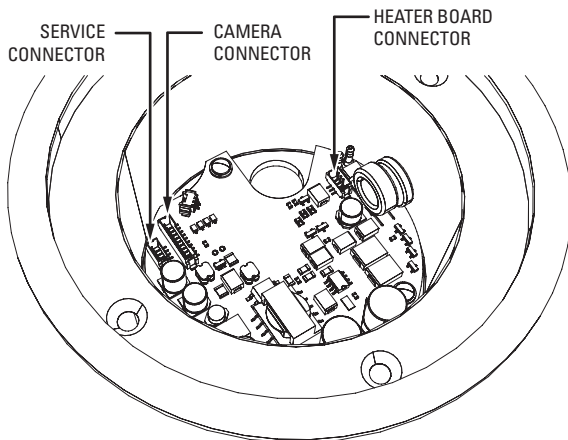

Figure 6. Back Box Connectors

CAMERA ORIENTATION

At the factory, the camera module is configured for ceiling mounting. For wall mounting, you must change the camera orientation or the video image could be upside down or sideways.

To change the camera orientation (refer to Figure 7):

1. Remove the camera module from the back box, if necessary.
2. Remove the tilt adjustment screw and lock washer from each side of the camera.
3. Carefully rotate the camera one quarter or one half turn, depending on the desired camera angle.

NOTES:

- Make sure to orient the top of the camera to the top of the field of view.
 - Make sure the wiring harness does not bind.
 - Make sure to orient the service connector away from the back box.
4. Reinstall the tilt adjustment screw and lock washer on each side of the camera.
 5. Verify the camera orientation.

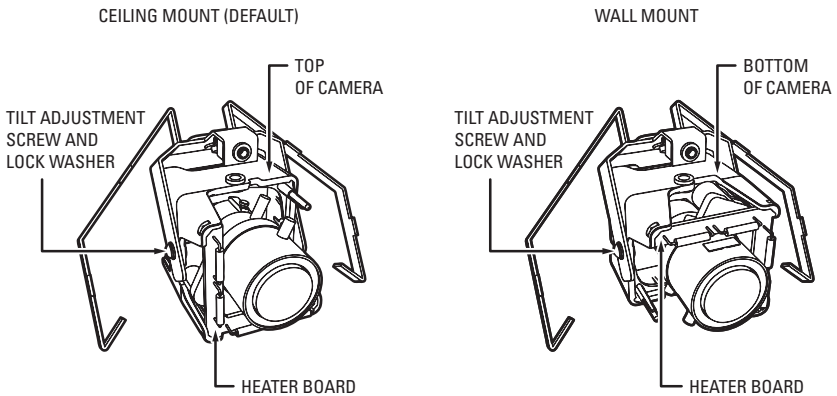

Figure 7. Camera Orientation

MODULE INSTALLATION

To install the camera module into the back box:

1. Plug the connectors into the back box in the following order (refer to Figure 6 on page 13):
 - a. Service (3-pin) connector
 - b. Camera (10-pin) connector
 - c. Heater board (4-pin) connector
2. Make sure the tabs on the camera bracket and the service connector are pointing out of the enclosure, away from the ceiling or wall.
3. Gently squeeze the bracket, place it against the groove inside the back box, and gently release (refer to Figure 5 on page 12).

Camera Adjustments

To perform the following camera adjustments, make sure to connect the camera and service connectors. You may have to remove the camera module from the back box.

Connect a monitor. Then turn on power to the camera and monitor. To use the service connector, refer to *Service Connector* on page 27.

To set the DIP switches, or to adjust the auto iris level (DN or CH) or the vertical phase (DW or CW), you will need a miniature trimpot adjustment tool with a 0.05-inch (1.27 mm) blade. Suggested tools include a miniature flat-tip screwdriver, a Philmore trimpot tool (#63-8608), and the Philmore 10-piece tool set (#63-910). To adjust the lens, you may also need a miniature Phillips screwdriver.

After you have adjusted the unit, reinstall the camera module into the back box, and then install the trim ring, bubble, and liner (if necessary).

VARIFOCAL LENS ZOOM AND FOCUS ADJUSTMENTS

NOTE: You will need a miniature Phillips or flat-tip screwdriver to loosen and tighten the locking screws.

To adjust the field of view:

1. Loosen the zoom locking screw (refer to Figure 8).
2. Turn the zoom adjustment ring clockwise or counterclockwise to select the field of view.
3. Tighten the zoom locking screw.

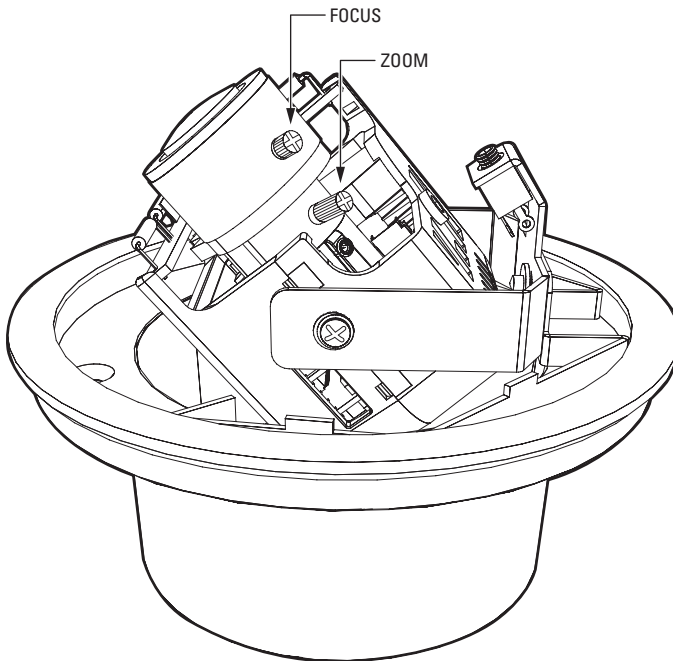

Figure 8. Location of Zoom and Focus Locking Screws

To adjust the focus:

1. Loosen the focus locking screw.
2. Position the inverted dome approximately 0.125 inch (3.175 mm) from the front of the lens. Make sure that the lens and the dome are centered (refer to Figure 9).
3. Turn the focus locking screw clockwise or counterclockwise to adjust the focus.
4. When the optimal focus is reached, tighten the focus locking screw

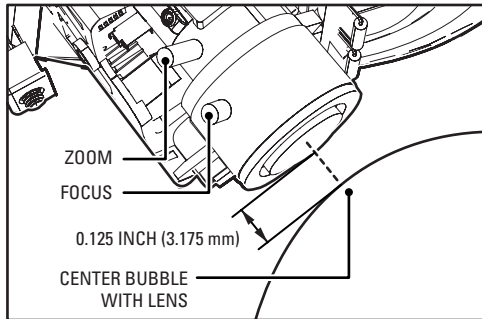

Figure 9. Adjusting the Focus

DN/CH SERIES ADJUSTMENTS

Refer to Figure 10 to adjust the IS150-DN or IS150-CH model.

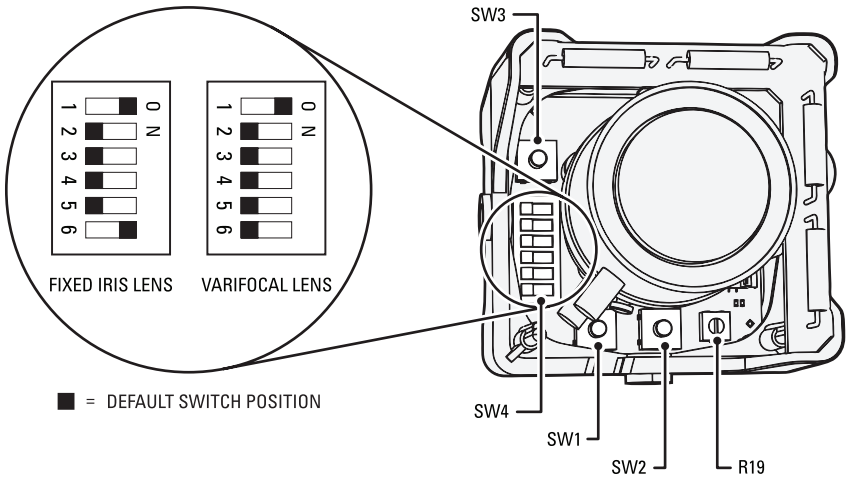

Figure 10. Adjusting the IS150-DN/CH Series Camcorder

SWITCH SETTINGS

Locate the DIP switch. Then set the switches for your installation.

SW4-1: Auto Gain Control

The automatic gain control (AGC) adjusts the image automatically to compensate for changes in light levels.

Set SW4-1 to ON to enable AGC. Set it to OFF to disable AGC. The default setting is ON.

SW4-2: Backlight Compensation

The backlight compensation (BLC) feature compensates for backlit scenes by enhancing objects in the center of the scene.

Set SW4-2 to ON to enable BLC. Use this setting if a bright backlight is present and the subject in the center of the picture appears dark or as a silhouette.

Set it to OFF to disable backlight compensation. This is the default setting.

SW4-3: Line Sync

When multiple cameras are connected to the same switching device, vertical roll may occur on the monitor. AC line lock eliminates vertical roll by locking the frame rate to the power supply frequency. Each camera output is synchronized to the power supply frequency (refer to *Vertical Phase Adjustment* on page 19 for more information).

Internal line sync disables line lock and synchronizes cameras internally.

Set SW4-3 to OFF to use AC line lock.

Set it to ON to use internal line sync. The default setting is OFF.

SW4-4: Flickerless

In certain lighting conditions, a flicker in the light source may affect camera operation. Flickering can be caused by a number of conditions, including the quality of the source power and the age and type of fluorescent bulbs and ballasts.

Set SW4-4 to ON to enable flickerless operation. The camera will remove the effects of flickering when present. The shutter speed will be set to 1/120 (NTSC) or 1/100 (PAL).

Set it to OFF to disable flickerless operation. This is the default setting.

NOTE: If you enable flickerless operation, you should use AC line lock for best results.

SW4-5: Auto White Balance/Manual White Balance

Auto white balance (AWB) is enabled by default (OFF).

To manually set and lock the white balance:

1. Set SW4-5 to OFF.
2. Hold a white background in front of the lens until the video shows all white.
3. While holding the background in place, set SW4-5 to ON. A blue blinking block appears on the video image for a few seconds. When the block changes to solid green, the manual white balance (MWB) process is complete.

SW4-6: Reserved

Do not change SW4-6 from its factory setting. SW4-6 must be set to OFF for Varifocal models; it must be set to ON for fixed-iris lenses.

AUTO IRIS LEVEL ADJUSTMENT

To adjust the auto iris DC-drive level (refer to Figure 10 on page 17):

1. Tilt or rotate the camera module until you can access the auto iris level control (R19).
2. Turn the screw clockwise to increase the brightness level or counterclockwise to decrease the brightness level.

VERTICAL PHASE ADJUSTMENT

Use this procedure for 24 VAC operation only.

When using more than one camera power supply, a brief vertical roll may occur on the monitor when switching from one camera to another.

To eliminate vertical roll, reverse the 24 VAC connections on one camera. If both cameras are connected to the same transformer, this should solve the problem. If the problem persists, adjust the phase control by synchronizing, or line-locking, the cameras to one another.

NOTE: When adjusting vertical phase, line sync (SW4-3) must be set to OFF for AC line lock.

Adjusting Vertical Phase

You may need two people when synchronizing the cameras: one at the camera, the other at the monitor to observe the vertical roll and the effect of any camera adjustments.

To synchronize the cameras:

1. Choose a reference camera to which all other cameras will be phased.
2. Select the camera to synchronize. Use buttons SW1 and SW2 to synchronize the camera to the reference camera (refer to Figure 10 on page 17). SW1 increases vertical phase; SW2 decreases vertical phase.
3. Each time an adjustment is made, switch back and forth between the camera you are adjusting and the reference camera. Repeat this process as many times as necessary until the roll between the cameras is no longer noticeable.
4. Adjust the phase of all other cameras by repeating steps 2 through 3. Always adjust to the reference camera selected in step 1.

NOTE: The preferred method for camera phase adjustment is to use a dual trace oscilloscope to align the vertical sync pulses of the reference camera to the selected camera(s).

BLEMISH DETECTION

If small white or color spots appear in the video image, one or more pixels on the camera imager may be defective. (This condition is common for both CCD and CMOS imagers.)

DN and CH Series cameras with auto iris lenses automatically detect and correct defective pixels during startup. Video turns on, then off, and then on again. If white or color spots still appear, you can correct the defective pixels manually.

CH Series cameras with fixed iris lenses do not automatically detect and correct defective pixels. You can correct the defective pixels manually.

To manually correct defective pixels (refer to Figure 10 on page 17):

1. Cover the lens completely. Make sure no light can enter the lens.
NOTE: The mechanical iris lens aperture does not completely block the light.
2. Press and hold button SW3 for one second. The camera will find and correct defective pixels; however, any defective pixels that cannot be completely corrected may still appear.
3. Release button SW3.
4. Uncover the lens for normal camera operation.

DAY/NIGHT OPERATION

NOTE: This section only applies to DN model cameras.

DN model cameras regularly check the brightness level of the field of view to determine when to switch between day (color) and night (black-white) operation.

Actual brightness threshold levels are affected by camera angle, amount of zoom, field of view, lens, and type of lighting. The switching process lasts from seven to 10 seconds.

Figure 11 and Table F show how the camera switches between color and black-white operation.

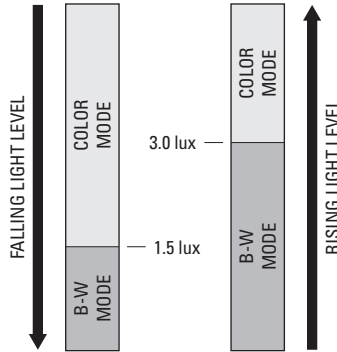

Figure 11. DN Models Threshold Switching Levels

Table F. DN Models Switching Thresholds

Color to B-W	1.5 lux ±1.0 lux
B-W to Color	3.0 lux ±1.0 lux

NOTE: These switching thresholds are approximate. Use the thresholds in Table F as a guide when installing the unit.

DW/CW SERIES (WIDE DYNAMIC RANGE) ADJUSTMENTS

Refer to Figure 12 to adjust the IS150-DW or IS150-CW model.

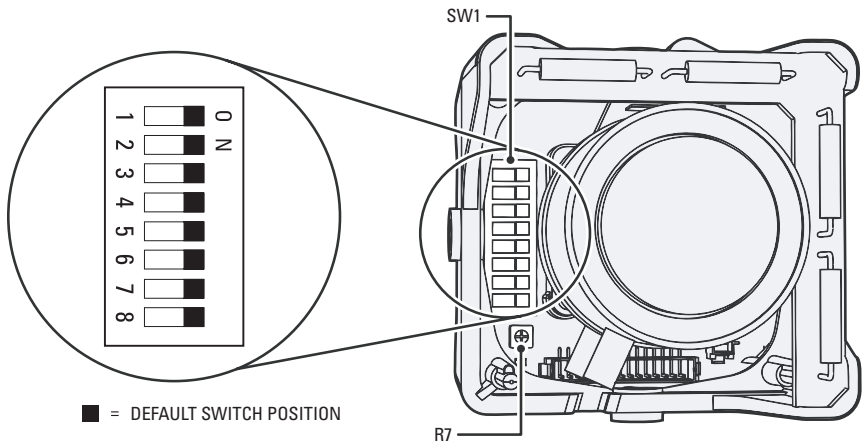

Figure 12. Adjusting the IS150-DW/CW Series Camclosure

SWITCH SETTINGS

Locate the DIP switch. Then set the switches for your installation.

SW1-1: Video Format

Set SW1-1 to ON for NTSC. Set it to OFF for PAL. The default setting is ON.

SW1-2: Line Sync

When multiple cameras are connected to the same switching device, vertical roll may occur on the monitor. AC line lock eliminates vertical roll by locking the frame rate to the power supply frequency. Each camera output is synchronized to the power supply frequency (refer to *Vertical Phase Adjustment* on page 24 for more information).

Internal line sync disables line lock and synchronizes cameras internally.

Set SW1-2 to ON to use AC line lock. Set it to OFF for internal line sync. The default setting is ON.

SW1-3: Interlaced Scanning/Progressive Scanning

Interlaced scanning is the standard for analog recording installations. Each frame contains one odd and one even field, each processed separately.

Progressive scanning is better for digital recording installations. Each frame is processed as a whole, which results in less blurring and cleaner digital conversion. It also saves storage space on digital video recorders.

Set SW1-3 to ON to select interlaced scanning. Set it to OFF to select progressive scanning. The default setting is ON.

SW1-4: Auto White Balance/Manual White Balance

Auto white balance (AWB) is enabled by default (ON).

To manually set and lock the white balance:

1. Set SW1-4 to ON.
2. Hold a white background in front of the lens until the video shows all white.
3. While holding the background in place, set SW1-4 to OFF. A green block and a white block alternate briefly on the video image until the manual white balance (MWB) process is complete.

SW1-5: Fluorescent/General

Enable this option to adjust the camera for best operation under fluorescent lighting.

Set SW1-5 to OFF for fluorescent lighting. Set it to ON for general lighting. The default setting is ON.

NOTE: If you use fluorescent operation, you should use AC line lock for best results.

SW1-6: General/Maximum Wide Dynamic Range

Maximum wide dynamic range (WDR) supports about 36 dB of additional dynamic range over a standard camera. Use it for installations that require the maximum WDR.

General WDR supports about 20 dB of additional dynamic range over a standard camera. Use it for installations that do not require the maximum WDR.

Set SW1-6 to ON to select maximum WDR. Set it to OFF to select general WDR. The default setting is ON.

SW1-7: DSS (Digital Slow Shutter)

The default shutter speed for NTSC is 30 frames per second (fps). It is 25 fps for PAL. This is also known as SENS 2X.

You can decrease the shutter speed to 7.5 fps (NTSC) or 6.25 fps (PAL). This is known as SENS 8X, which improves low light sensitivity.

Set SW1-7 to ON to select SENS 2X. Set it to OFF to select SENS 8X. The default setting is ON.

SW1-8: Day/Night Operation (DW models only)

NOTE: On CW models, SW1-8 is unused and does not affect camera operation.

DW model cameras regularly check the brightness level of the field of view to determine when to switch between day (color) and night (black-white) operation. Use SW1-8 to set the general light levels at which the camera will automatically switch.

Set SW1-8 to ON (dark) to use standard thresholds to switch between color and black-white operation. This is the default.

Set it to OFF (dusk) to use higher light thresholds to switch between color and black-white operation.

Actual brightness threshold levels are affected by camera angle, amount of zoom, field of view, lens, and type of lighting. The switching process lasts from seven to 10 seconds.

NOTE: If the camera switches between day/night mode at least three consecutive times within a short time period, the camera will remain in the last mode for 10 minutes. To override this 10-minute pause, cycle the power or expose the camera to an extreme light level change (for example, from very dim light to very bright light).

Figure 13 and Table G show how the camera switches between color and black-white operation for each setting.

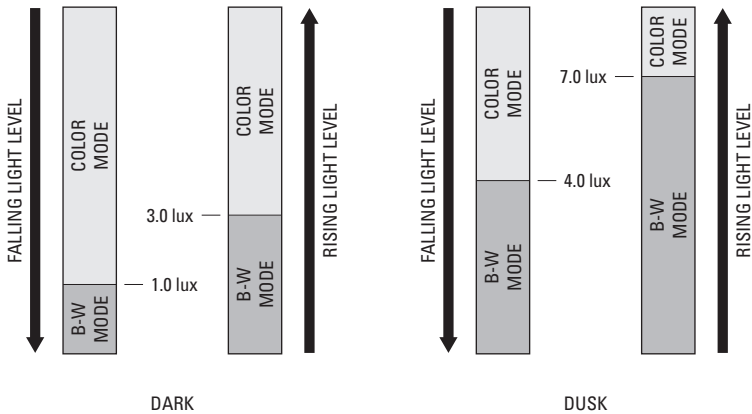

Figure 13. DW Models Threshold Switching Levels

Table G. DW Models Switching Thresholds

	Dark (ON)	Dusk (OFF)
Color to B-W	1.0 lux	4.0 lux
B-W to Color	3.0 lux	7.0 lux

NOTE: These switching thresholds are approximate and were measured using a 3.0 to 9.5 mm lens at f/1.0. Use the thresholds in Table G as a guide when installing the unit.

AUTO IRIS LEVEL ADJUSTMENT

The electronics of the IS150-DW and IS150-CW Series Camclosures automatically adjust the camera to the auto iris. Auto iris level adjustments are not necessary.

VERTICAL PHASE ADJUSTMENT

Use this procedure for 24 VAC operation only.

When using more than one camera power supply, a brief vertical roll may occur on the monitor when switching from one camera to another.

To eliminate vertical roll, reverse the 24 VAC connections on one camera. If both cameras are connected to the same transformer, this should solve the problem. If the problem persists, adjust the phase control by synchronizing, or line-locking, the cameras to one another.

NOTE: When adjusting vertical phase, line sync (SW1-2) must be set to ON for AC line lock.

Adjusting Vertical Phase

You may need two people when synchronizing the cameras: one at the camera, the other at the monitor to observe the vertical roll and the effect of any camera adjustments.

To synchronize the cameras:

1. Choose a reference camera to which all other cameras will be phased.
2. Select the camera to synchronize. Use the phase adjustment control (R7) to synchronize the camera to the reference camera (refer to Figure 12 on page 21). Turn R7 clockwise to increase vertical phase; turn R7 counterclockwise to decrease vertical phase.
3. Each time an adjustment is made, switch back and forth between the camera you are adjusting and the reference camera. Repeat this process as many times as necessary until the roll between the cameras is no longer noticeable.
4. Adjust the phase of all other cameras by repeating steps 2 through 3. Always adjust to the reference camera selected in step 1.

NOTE: The preferred method for camera phase adjustment is to use a dual trace oscilloscope to align the vertical sync pulses of the reference camera to the selected camera(s).

BLEMISH DETECTION

If small white or color spots appear in the video image, one or more pixels on the camera imager may be defective. (This condition is common for both CCD and CMOS imagers.)

DW and CW Series cameras have auto iris lenses and automatically detect and correct defective pixels during startup. Manual pixel correction is not available.

Camera Positioning

Rotate and tilt the camera module to position the camera. Then tighten the tilt screws (axis **1** in Figure 14).

NOTE: Do not over-rotate the module. Excessively turning the module in one direction could result in damage to the wiring.

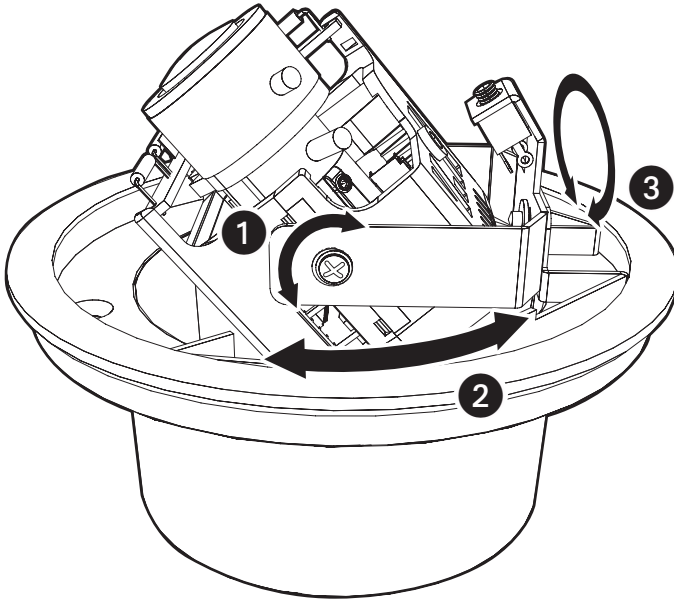

- 1** Tilt 80° (20° to 100°) **2** Pan 360° **3** Rotation 360°

Figure 14. Positioning the Camera

Install Liner and Trim Ring

1. Adjust the liner (if installed), refer to Figure 15:
 - a. Align the screw holes in the trim ring with those in the back box to identify the proper liner position.
 - b. Loosen the three Phillips screws located in the trim ring.
 - c. Insert the blade of a standard screwdriver in one of the adjustment grooves. Rotate the liner to position the viewing window over the camera lens.
 - d. Tighten the three Phillips screws to lock the liner in place.

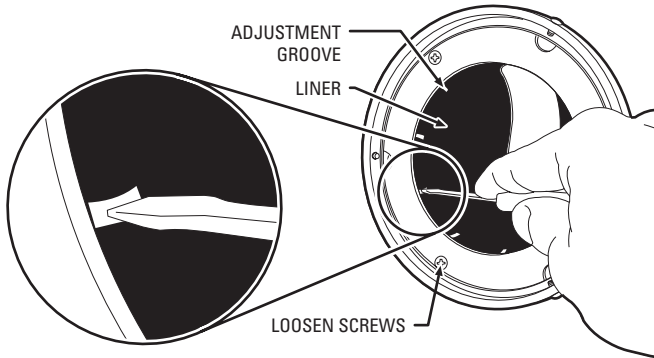

Figure 15. Adjusting the Liner

2. Place the trim ring onto the back box.
3. Tighten the tamper-resistant screws through the trim ring into the back box. Use the 1/8-inch hollow screwdriver bit (supplied).

NOTE: The screws are installed at an angle.

Service Connector

The IS150 Series Camclosure integrated camera system includes a service connector that outputs camera video. Use it at the installation site to set up the field of view and to focus the camera.

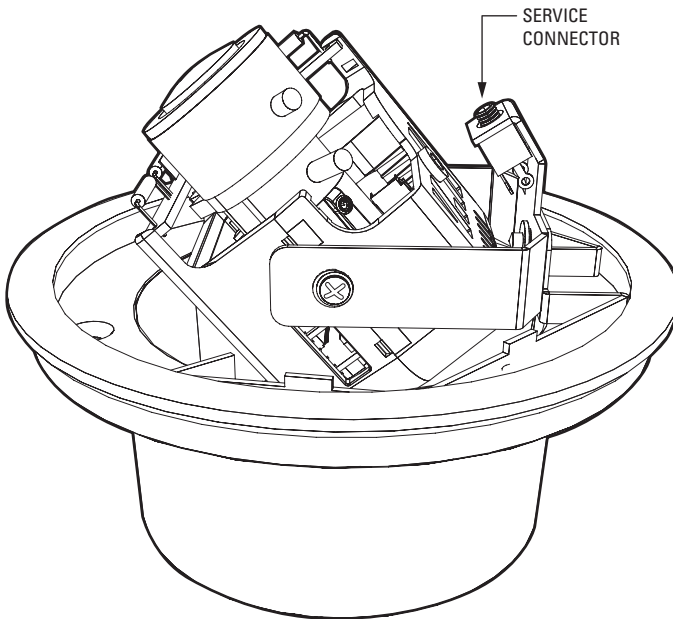

Figure 16. Service Connector

Pelco offers two optional items that plug directly into the service connector. Before using either option, you must loosen the tamper-resistant screws to remove the trim ring from the back box. Use the 1/8-inch hollow screwdriver bit (supplied).

The optional CST150 has a 3-foot (0.9 m) cable and microdisplay for viewing camera video. Plug it into the service connector and view the video.

NOTE: The three buttons on the CST150 are not used with the IS150 Series Camclosure.

The optional IS-SC is a 4-foot (1.2 m) cable with a service connector and a BNC connector. Plug the service connector into the unit. Then connect the other end to any standard BNC (VIDEO IN) connector on a monitor.

To assemble a longer service cable for the Camclosure integrated camera system, purchase the following items from a local electronics supply store:

Qty Description

- 1 2.5 mm monaural headphone plug
- 1 CPM 88 miniature coaxial connector
- 1 RG174/U coaxial cable

To assemble the cable:

1. Attach the CPM 88 miniature coaxial connector to one end of the cable. Follow the directions supplied with the miniature coaxial connector.
2. Attach the 2.5 mm monaural plug to the other end of the coaxial cable (refer to Figure 17):
 - a. Remove the support sleeve from the plug.
 - b. Slip the support sleeve over the end of the cable.
 - c. Prepare the cable.
 - d. Solder the center connector of the cable to the center pin of the plug.
 - e. Thread the braid of the cable through the hole in the crimp pin.
 - f. Solder the braid to the top of the crimp pin.
 - g. Crimp the end of the crimp pin around the cable.
 - h. Reassemble the support sleeve and the plug.

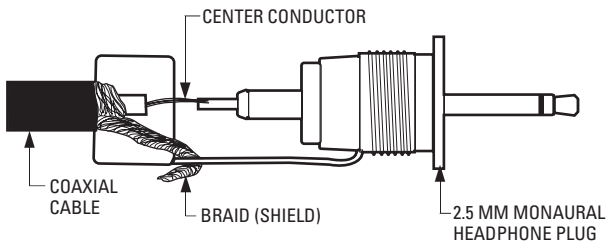

Figure 17. Attaching the 2.5 mm Monaural Headphone Plug

Specifications

GENERAL

Pan/Tilt Adjustment	Manual
Pan	360°
Tilt	80° (20° to 100° range)
Rotation	360°
Construction	Aluminum with steel camera mounting bracket and polycarbonate dome
Finish	White polyester powder coat trim ring with gray polyester powder coat back box
Light Attenuation	
Smoked	f/1.5 light loss
Clear	Zero light loss
Unit Weight	1.70 lb (0.77 kg)

ELECTRICAL

Input Voltage*	12 VDC or 24 VAC ($\pm 10\%$), autosensing
Synchronization	Internal or AC line lock
Power Consumption	
Camera	<3 W (DW/CW models) <4 W (DN/CH models)
Heaters	10 W when active, thermostatically controlled

*24 VAC power is recommended when installing any Camclosure Integrated Camera System under fluorescent lighting conditions.

VIDEO

Signal System	NTSC or PAL
Video Output	
Composite	1 Vp-p (75 ohms)
UTP	1 Vp-p (100 ohms)
Video Connectors	1 composite BNC and 1 UTP
Service Connector	3-conductor, 2.5 mm connector for video output to optional IS-SC cable

ENVIRONMENTAL

Environment	Low temperature, indoor/outdoor
Operating Temperature	-50° to 122°F (-46° to 50°C); de-ices to 25°F (-4°C)
Thermostat Operation	Heater is thermostatically controlled to activate ON at 50°F (10°C) and OFF at 80°F (27°C)

CAMERA/LENS

If you need technical specifications for the camera itself, refer to the IS150 specification online at www.pelco.com.

(Design and product specifications subject to change without notice.)

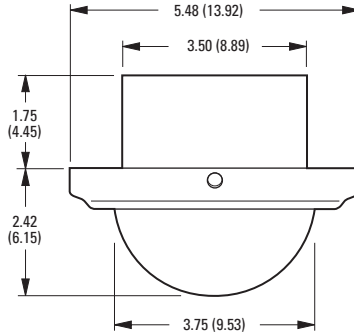

NOTE: VALUES IN PARENTHESES ARE CENTIMETERS;
ALL OTHERS ARE INCHES.

REVISION HISTORY

Manual #	Date	Comments
C3427M	2/07	Original version.
C3427M-A	5/07	Updated switch setting and day/night operation descriptions.
C3427M-B	7/07	Changed part name of service connector from ICS-SC to IS-SC per CN20476.
C3427M-C	10/07	Revised illustrations for the threshold switching levels.
C3427M-D	2/09	Added a lens focus procedure to <i>Camera Adjustments</i> .

PRODUCT WARRANTY AND RETURN INFORMATION

WARRANTY

Pelco will repair or replace, without charge, any merchandise proved defective in material or workmanship **for a period of one year** after the date of shipment.

Exceptions to this warranty are as noted below:

- Five years:
 - Fiber optic products
 - TW3000 Series unshielded twisted pair (UTP) transmission products
 - CC3701H-2, CC3701H-2X, CC3751H-2, CC3651H-2X, MC3651H-2, and MC3651H-2X camera models
- Three years:
 - Pelco-branded fixed camera models (CCC1390H Series, C10DN Series, C10CH Series, IP3701H Series, and IX Series)
 - EH1500 Series enclosures
 - Spectra[®] IV products (including Spectra IV IP)
 - Camclosure[®] Series (IS, ICS, IP) integrated camera systems
 - DX Series digital video recorders, DVR5100 Series digital video recorders, Digital Sentry[®] Series hardware products, DVX Series digital video recorders, and NVR300 Series network video recorders
 - Endura[®] Series distributed network-based video products
 - Genex[®] Series products (multiplexers, server, and keyboard)
 - PMCL200/300/400 Series LCD monitors
- Two years:
 - Standard varifocal, fixed focal, and motorized zoom lenses.
 - DF5/DF8 Series fixed dome products
 - Legacy[®] Series integrated positioning systems
 - Spectra III[™], Spectra Mini, Spectra Mini IP, Esprit[®], ExSite[®], and PS20 scanners, including when used in continuous motion applications.
 - Esprit Ti and TI2500 Series thermal imaging products
 - Esprit and VVV5700 Series window wiper (excluding wiper blades).
 - CM6700/CM6800/CM9700 Series matrix
 - Digital Light Processing (DLP[®]) displays (except lamp and color wheel). The lamp and color wheel will be covered for a period of 90 days. The air filter is not covered under warranty.
 - Intelli-M[®] eIDC controllers
- One year:
 - Video cassette recorders (VCRs), except video heads. Video heads will be covered for a period of six months.
- Six months:
 - All pan and tilts, scanners, or preset lenses used in continuous motion applications (preset scan, tour, and auto scan modes).

Pelco will warrant all replacement parts and repairs for 90 days from the date of Pelco shipment. All goods requiring warranty repair shall be sent freight prepaid to a Pelco designated location. Repairs made necessary by reason of misuse, alteration, normal wear, or accident are not covered under this warranty.

Pelco assumes no risk and shall be subject to no liability for damages or loss resulting from the specific use or application made of the Products. Pelco's liability for any claim, whether based on breach of contract, negligence, infringement of any rights of any party or product liability, relating to the Products shall not exceed the price paid by the Dealer to Pelco for such Products. In no event will Pelco be liable for any special, incidental, or consequential damages (including loss of use, loss of profit, and claims of third parties) however caused, whether by the negligence of Pelco or otherwise.

The above warranty provides the Dealer with specific legal rights. The Dealer may also have additional rights, which are subject to variation from state to state.

If a warranty repair is required, the Dealer must contact Pelco at (800) 289-9100 or (559) 292-1981 to obtain a Repair Authorization number (RA), and provide the following information:

1. Model and serial number
2. Date of shipment, P.O. number, sales order number, or Pelco invoice number
3. Details of the defect or problem

If there is a dispute regarding the warranty of a product that does not fall under the warranty conditions stated above, please include a written explanation with the product when returned.

Method of return shipment shall be the same or equal to the method by which the item was received by Pelco.

RETURNS

To expedite parts returned for repair or credit, please call Pelco at (800) 289-9100 or (559) 292-1981 to obtain an authorization number (CA number if returned for credit, and RA number if returned for repair) and designated return location.

All merchandise returned for credit may be subject to a 20 percent restocking and refurbishing charge.

Goods returned for repair or credit should be clearly identified with the assigned CA or RA number and freight should be prepaid

12-23-08

Pelco, the Pelco logo, Camclosure, Digital Sentry, Endura, Esprit, ExSite, Genex, Intelli-M, Legacy, and Spectra are registered trademarks of Pelco, Inc. Spectra III is a trademark of Pelco, Inc.

DLP is a registered trademark of Texas Instruments Incorporated.

All product names and services identified throughout this document are trademarks or registered trademarks of their respective companies.

The absence of a trademark or registered trademark from this document does not constitute a waiver of intellectual property rights.

© Copyright 2009, Pelco, Inc. All rights reserved.

PELCO

by **Schneider** Electric

www.pelco.com

Pelco, Inc. Worldwide Headquarters 3500 Pelco Way Clovis, California 93612 USA
USA & Canada Tel (800) 289-9100 Fax (800) 289-9150
International Tel +1 (559) 292-1981 Fax +1 (559) 348-1120

Free Manuals Download Website

<http://myh66.com>

<http://usermanuals.us>

<http://www.somanuals.com>

<http://www.4manuals.cc>

<http://www.manual-lib.com>

<http://www.404manual.com>

<http://www.luxmanual.com>

<http://aubethermostatmanual.com>

Golf course search by state

<http://golfingnear.com>

Email search by domain

<http://emailbydomain.com>

Auto manuals search

<http://auto.somanuals.com>

TV manuals search

<http://tv.somanuals.com>