

**PT550P Series  
Medium Duty  
Pan/Tilt**

**Installation/  
Operation Manual**

**C325M-C (6/99)**

Pelco • 3500 Pelco Way, Clovis • CA 93612-5699 USA • [www.pelco.com](http://www.pelco.com)  
In North America and Canada: Tel (800) 289-9100 or FAX (800) 289-9150  
International Customers: Tel (1-559) 292-1981 or FAX (1-559) 348-1120

---



---

# CONTENTS

---



---

<b>Section</b>	<b>Page</b>
1.0 GENERAL .....	3
1.1 IMPORTANT SAFEGUARDS AND WARNINGS .....	3
2.0 DESCRIPTION .....	4
2.1 MODELS .....	4
2.2 OPTIONS .....	4
2.3 RATINGS .....	4
3.0 INSTALLATION .....	5
3.1 MOUNTING .....	5
3.2 CAMERA/ENCLOSURE MOUNTING .....	5
3.3 WIRING .....	5
3.3.1 Mating Connector Assembly .....	7
3.4 LIMIT STOP ADJUSTMENTS .....	10
4.0 OPERATION .....	11
5.0 TROUBLESHOOTING .....	12
5.1 SERVICE MANUAL .....	12
6.0 MAINTENANCE .....	13
6.1 Tightening Drive Chains .....	13
6.2 Chain Drive Lubrication .....	13
7.0 SPECIFICATIONS .....	14
8.0 WARRANTY AND RETURN INFORMATION .....	16

## LIST OF ILLUSTRATIONS

<b>Figure</b>	<b>Page</b>
1 Sealant Locations .....	5
2 Connector Assembly .....	7
3 PT550P Wiring Diagram .....	8
4 PT550P/PP Wiring Diagram .....	9
5 Limit Stops .....	10
6 Servicing the Pan/Tilt .....	13
7 PT550P Series Dimension Drawing .....	15

## LIST OF TABLES

<b>Table</b>	<b>Page</b>
A Maximum Cable Distances .....	6

## REVISION HISTORY

<b>Manual #</b>	<b>Date</b>	<b>Comments</b>
C325M-C	10/98	Changed manual to new format. Added ratings. Revised installation instructions. Moved exploded assembly diagram, parts lists, and potentiometer adjustment to maintenance/service manual. Reversed wire colors for pins 5 and 8 in wiring schematics.
	6/99	Revised Figures 3 & 4 to include wiring for HB option.

---

---

## 1.0 GENERAL

---

---

### 1.1 IMPORTANT SAFEGUARDS AND WARNINGS

Prior to installation and use of this product, the following WARNINGS should be observed.

1. Installation and servicing should only be done by qualified service personnel and conform to all local codes.
2. Unless the unit is specifically marked as a NEMA Type 3, 3R, 3S, 4, 4X, 6, or 6P enclosure, it is designed for indoor use only and it must not be installed where exposed to rain and moisture.
3. The weight of the camera, lens, and enclosure shall not exceed 40 lb (18.16 kg), subject to specific pan/tilt unit.
4. Only use replacement parts recommended by Pelco.
5. After replacement/repair of this unit's electrical components, conduct a resistance measurement between line and exposed parts to verify the exposed parts have not been connected to line circuitry.
6. The installation method and materials should be capable of supporting four times the weight of the enclosure, pan/tilt, camera and lens combination.

#### The product and/or manual may bear the following marks:



This symbol indicates that dangerous voltage constituting a risk of electric shock is present within this unit.



This symbol indicates that there are important operating and maintenance instructions in the literature accompanying this unit.

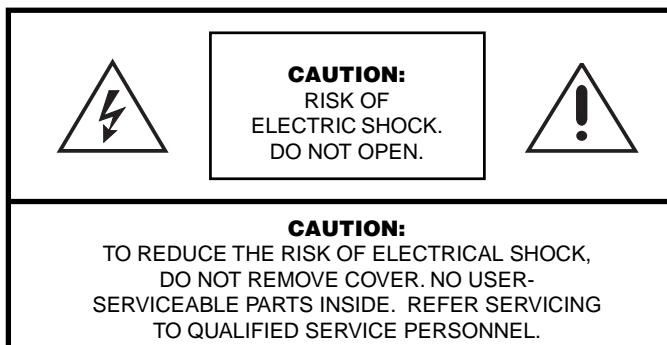

**Please thoroughly familiarize yourself with the information  
in this manual prior to installation and operation.**

---

---

## 2.0 DESCRIPTION

---

---

Pan/tilts in the PT550P Series are designed to remotely position a TV camera in both the horizontal and vertical attitudes. Pan (horizontal) and tilt (vertical) movements are caused by activating small DC motors in the pan/tilt unit. All Pelco units are equipped with adjustable limits for both pan and tilt, and all motors are equipped with electrical filtering circuits to suppress RF interference.

The drive motors employ a permanent magnet type of field. The voltages applied to the armature can be varied in magnitude to change motor speed and are reversed in polarity to change the direction of movement.

Braking is accomplished by electrically short-circuiting the motor armature. During normal operation, dynamic braking is accomplished in the control unit by short-circuiting both sides of the armature to the supply common. When a pre-adjusted limit is encountered during operation, limit switches remove the driving voltage and apply a short circuit to the motor armature.

### 2.1 MODELS

PT550P	Medium duty pan/tilt, 115 VDC
PT550P/FGP	Medium duty pan/tilt, 115 VDC, with special speed gearing for pan (9°/sec pan speed)
PT550P/HB	Medium duty pan/tilt, 115 VDC, with blanket heater in cover. 75 watts total. 120 VAC.
PT550P/PP	Medium duty pan/tilt, 115VDC, with position feedback modification. Requires preset control or control having AZL option (position indication meter).
PT550P/RAD	Medium duty pan/tilt, 115 VDC, with radiation resistant wiring and white epoxy paint. Low level radiation resistant up to 10 <sup>6</sup> rads

### 2.2 OPTIONS

FG/570	Special high speed gears — 9°/4.5° per sec pan/tilt speed. (Reduces load to 20 lb or 9.08 kg)
FGT/570	Special high-speed gearing for tilt — 4.5°/sec tilt speed. (Reduces load to 20 lb or 9.08 kg)

### 2.3 RATINGS

- NEMA Type 3R
- IP 32

---

---

## 3.0 INSTALLATION

---

---



**CAUTION:** Pan/tilts in the PT550P Series are designed for upright or inverted operation and should never be mounted horizontally.

Pan/tilts in the PT550P Series are designed to mount onto a horizontal surface in the upright or inverted position.

In order to ensure proper wiring and system operation of all components, it is recommended that you test the pan/tilt and the associated control equipment in your facility before field installation. Refer to Sections 3.3 through 3.4.

### 3.1 MOUNTING

**NOTE:** When mounting the pan/tilt outdoors in the inverted position (base up), RTV silicone sealant, such as Dow Corning Type 732 or equivalent, should be applied to the areas indicated in Figure 1.

Attach the pan/tilt unit to a mount, following the instructions that accompany the mount. To ensure maximum pan travel, mount the pan/tilt so that the fixed limit stop is directly opposite the center of the intended viewing area.

Make sure the mounting surface and the mounting method is strong enough to support four times the combined weight of the pan/tilt, enclosure, camera and lens.

### 3.2 CAMERA/ENCLOSURE MOUNTING

Attach the enclosure, camera and lens to the pan/tilt unit with 1/4-20 hardware (not supplied). The enclosure, camera and lens must be correctly mounted and balanced on the tilt table for proper operation.

### 3.3 WIRING

Cable distances for pan and tilt motors should not exceed the distances specified in Table A. Cable fabrication must be in accordance with Section 3.3.1, Mating Connector Assembly. The following are some recommended common installation practices.

1. Always use jacketed stranded multi-conductor interconnecting cable between the control and the pan/tilt unit, with additional conductors than needed for future servicing and or additions.
2. Always use color-coded conductors for ease of wiring and to identify functions at a later date.
3. Keep a wiring diagram with the system for later use and reference.

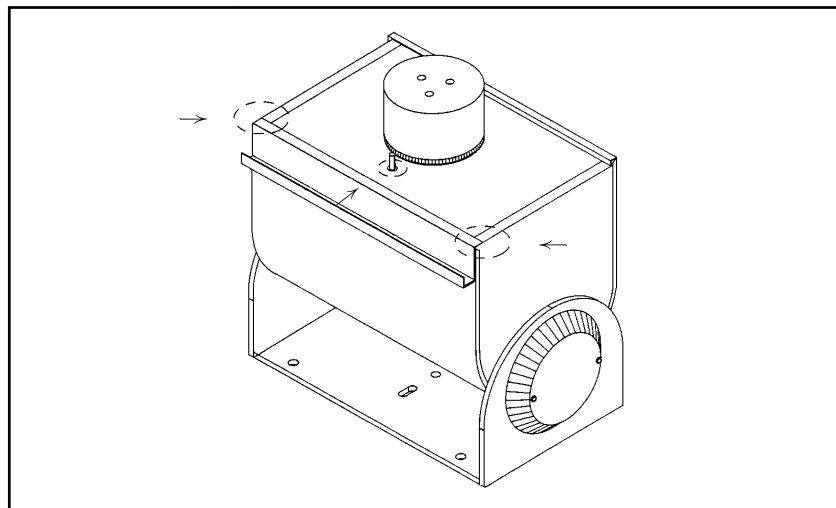

Figure 1 . Sealant Locations

**Table A . Maximum Cable Distances**

Wire Size	Maximum Distance
20 AWG	635 feet (193.55 m)
18 AWG	1,015 feet (309.37 m)
16 AWG	1,610 feet (490.73 m)

Distances are calculated with both motors (pan/tilt) running and assuming a 10% voltage drop in cable.

### 3.3.1 Mating Connector Assembly

**NOTE:** Contacts cannot be removed from the connector without the use of the appropriate AMP extraction tool (ZT305183), which is available from Pelco.

**NOTE:** When a pan/tilt is mounted in the inverted position, the LEFT/RIGHT and UP/DOWN functions are reversed during operation. To correct this problem, reverse the LEFT/RIGHT functions in the control cable (pins 3 and 7) at the pan/tilt or control and the UP/DOWN functions (pins 5 and 6) at the pan/tilt or control.

To assemble the mating connectors, refer to Figure 2 and perform the following steps.

The instructions that follow apply to all AMP style connectors regardless of pin size or pin number.

1. Slide the connector clamp assembly over the conductor cable. If the diameter of the conductor cable is such that the rubber boot will slide over it easily, slide the rubber boot onto the conductor cable at this time. If not, discard the rubber boot.
2. Refer to Detail A in Figure 2. Prepare the wires from the conductor cable as follows:
  - a. Strip at least 1-inch (2.54 cm) from the cable jacket to expose the wires. You may need to strip more from the cable jacket if you have more wires.
  - b. Strip 1/8-inch (0.125 cm) from each wire.
  - c. Using an AMP style crimper, crimp the wires and their insulation to the connector pins.
3. Slide the connector pins into the appropriate holes in the connector body until they snap into place. Refer to detail B in Figure 2 and to Figure 3 or 4 for correct pin arrangement, depending on model and options.
4. Push the connector clamp assembly (with boot, if used) toward the connector body. Screw the clamp assembly onto the connector body, being careful not to disturb the wires.
5. To complete the assembly, attach the appropriate clamp with the screws provided and tighten.

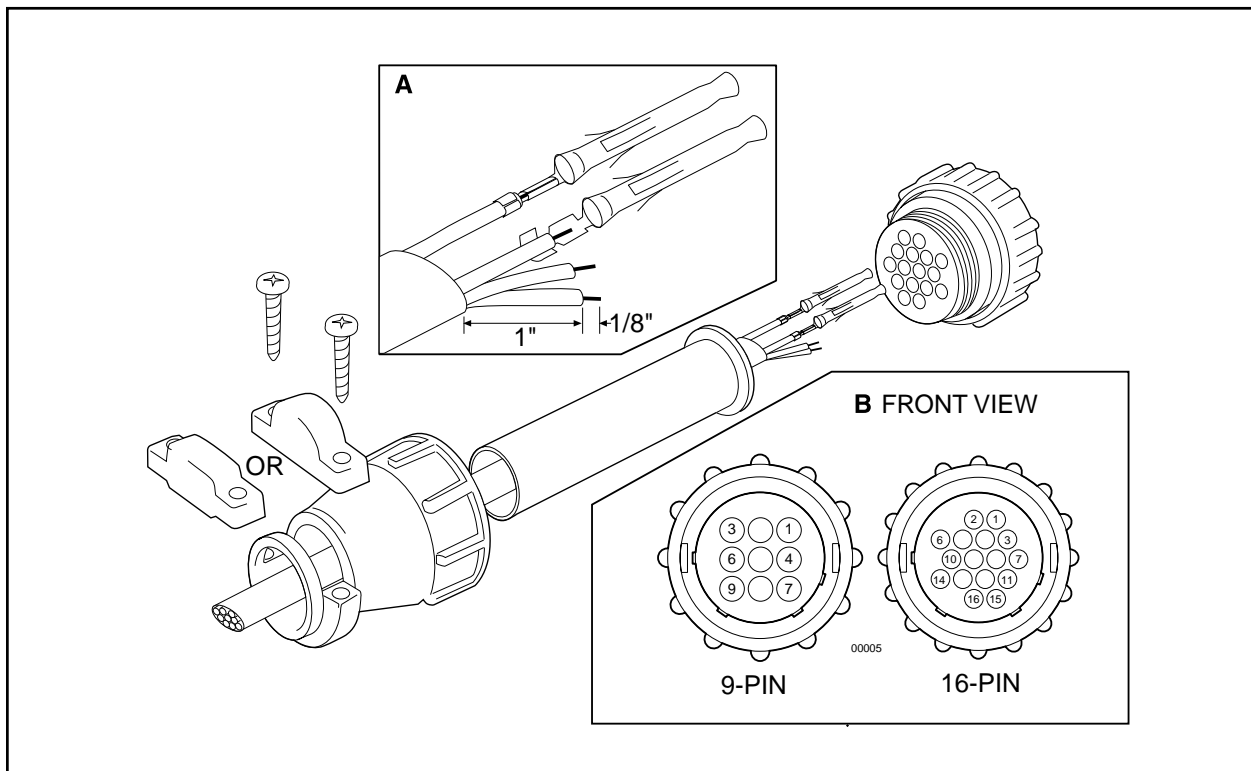

Figure 2. Connector Assembly

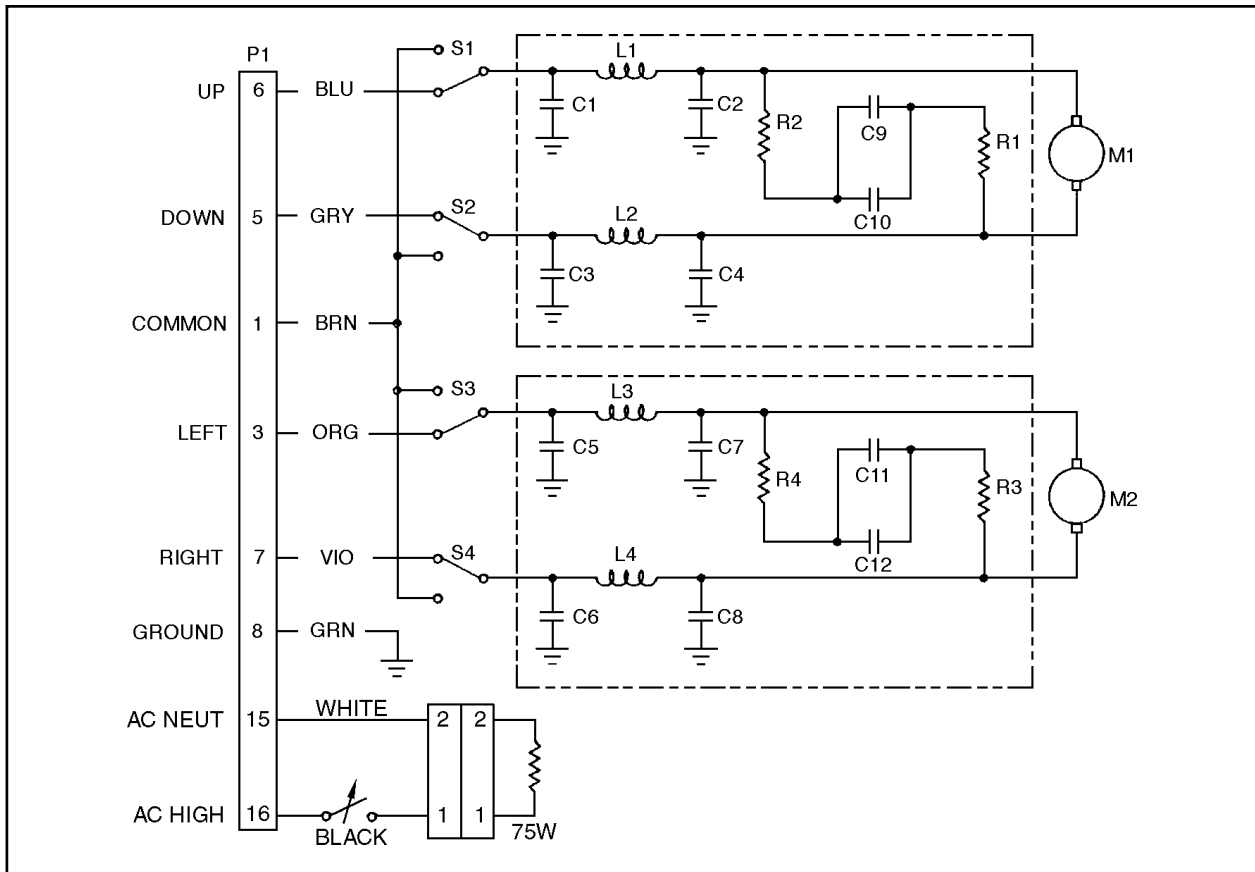

Figure 3. PT550P Wiring Diagram (including HB Option)



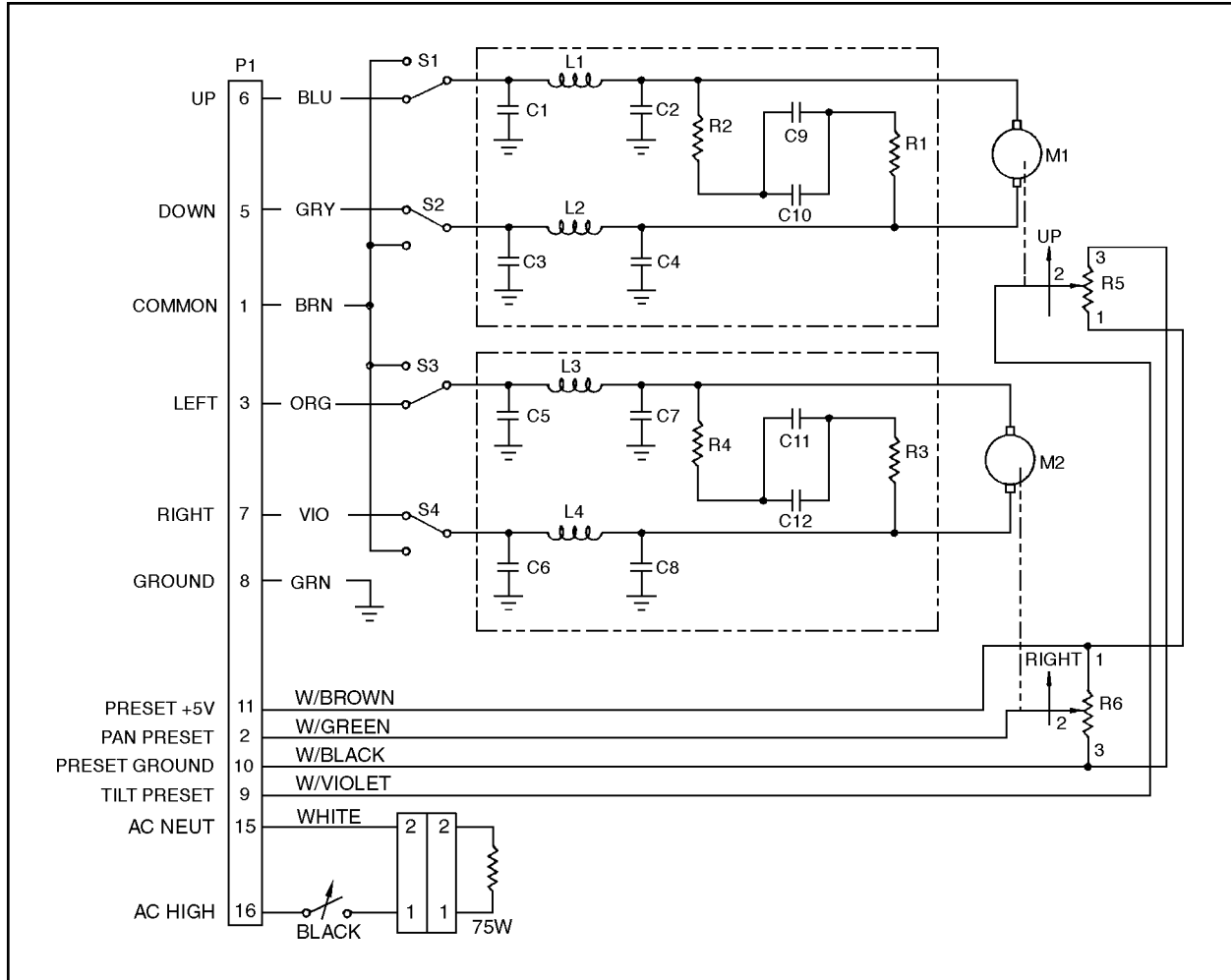

Figure 4. PT550P/PP Wiring Diagram (including HB Option)

### 3.4 LIMIT STOP ADJUSTMENTS



**WARNING: Do not operate the pan/tilt without limit stops.**

*Do not attempt to adjust the limit stops while the unit is operating. Personal injury or damage to the unit may result.*

**Do not** remove or reposition the fixed limit stop on the pan/tilt. **DAMAGE WILL OCCUR.**

To set pan/tilt limit stops, perform the following steps. Refer to Figure 5.

1. Loosen the pan limit stops.
2. Turn the control unit on. Pan the unit to the right until the desired right pan limit is reached.
3. Move the right pan limit stop until it touches the pan limit switch actuator. Move the stop a slight distance further against the actuator until it clicks to indicate the opening of the limit switch. Lock the stop in place.
4. Pan the unit to the desired left position. Adjust the left pan limit stop as described in step 3.
5. Pan left and right to both limit stops and check for exact positioning. Tighten both stops securely.
6. Remove the cover plate from the left side of the tilt table. Loosen the limit stop screws and tilt the table, using the joystick, to the desired up position.
7. Move the up limit stop until it touches the tilt limit switch actuator and clicks. Lock the stop in place.
8. Tilt the table to the desired down position and set the stop in the same manner.
9. Tilt the table up and down and check for exact positioning. Tighten both stops securely. Replace the cover plate.

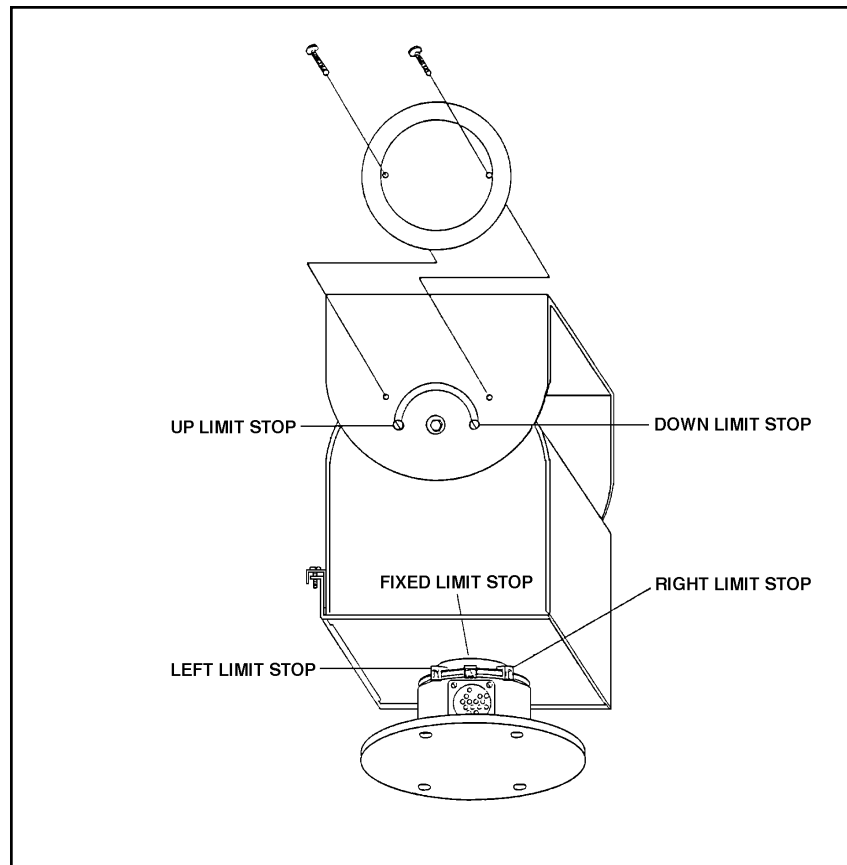

Figure 5. Limit Stops

---

---

## **4.0 OPERATION**

---

---

| Refer to the manual for your control equipment for operating the pan/tilt.

---

---

## 5.0 TROUBLESHOOTING

---

---

Some common problems encountered with pan/tilt systems include miswiring, overloading, and not using the units for the correct application. If the pan/tilt unit fails to operate, do the following:

1. Check the fuse in the control unit. If the fuse is bad, replace it.
2. If the fuse blows after replacing it, check the control cable between the control unit and the pan/tilt for shorts, high resistance, or opens.
3. If the control cable is good, reconnect it to the control unit but not to the pan/tilt. Replace the fuse and operate the control unit. If the fuse blows again, the fault is in the control.

Refer to Figure 3 or 4 for the following steps.

4. If the control unit is good, check the wiring harness in the pan/tilt for shorts.
5. If the wiring harness is good, the problem is internal to the unit; consult the factory.

### 5.1 SERVICE MANUAL

If you need to service your unit, obtain a service manual in one of the following ways:

- Go to Pelco's web site at <http://www.pelco.com> and find service manual C325SM.
- Contact Pelco's Literature Department and request service manual C325SM.

---

---

## 6.0 MAINTENANCE

---

---

Inspect the pan/tilt unit every six months to ensure trouble-free operation and an extended product life. Harsh environments and/or continuous motion applications may require more frequent maintenance.

Please read all of the instructions that follow before servicing the pan/tilt.

To begin, remove the three screws on the front of the pan/tilt housing and lift the cover to gain access to the pan and tilt motor assemblies.

### 6.1 TIGHTENING DRIVE CHAINS

Check the pan and tilt drive chains for tension. A movement of 1/32 of an inch to 3/32 of an inch in the chains is acceptable. If the movement of a chain exceeds 3/32 of an inch, adjust the chain as follows:

1. Loosen the screws securing the motor to the mounting frame.
2. Pry on the motor to apply tension to the chain. Do not over-tension the drive chain.
3. Keep tension on the chain while tightening the screws.

### 6.2 CHAIN DRIVE LUBRICATION

Sprockets, chains, and gears should be well greased. If necessary, lubricate the pan and tilt gears, sprockets, and chains as follows with a high-quality grease capable of withstanding temperatures from -50° to 170°F (-46° to 77°C). Do the following:

1. Liberally apply grease to the pan and tilt gears, chains, and sprockets (refer to Figure 6).
2. Operate the pan and tilt motors to spread the grease across the parts.
3. Apply additional grease if necessary.
4. Reinstall the cover. If the pan/tilt is installed outdoors in an inverted position, apply RTV silicone sealant as shown in Figure 1.

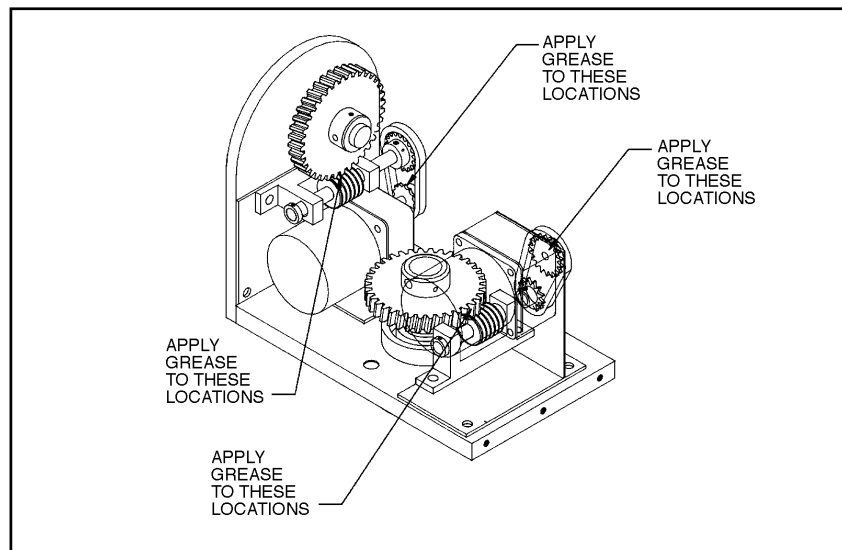

**Figure 6.** Servicing the Pan/Tilt

---

---

## 7.0 SPECIFICATIONS

---

---

### **MECHANICAL**

Pan:	0-355° movement in horizontal plane Speed 6°/sec ±1° (No load condition)
Tilt:	±90° movement in vertical plane Speed 3°/sec ± .5° (No load condition) Torque 20 ft/lb with specified voltage
Maximum Load:	40 lb (18.16 kg) at 5 inches (12.7 cm) from tilt table surface to center of gravity
Gearing:	Adjustable worm-gear final drive to prevent drift and minimize backlash
Bearings	
Pan:	Heavy-duty ball bearings
Tilt:	Oilite bronze bushing
Braking:	Dynamic for instantaneous stopping

### **ELECTRICAL**

Input Voltage:	115 VDC required for pan/tilt
Power Requirements	
Pan:	Running: .30 amp (34 vA)
Tilt:	.30 amp (34 vA)
Pan:	Starting: .44 amp (51 vA)
Tilt:	.44 amp (51 vA)
Connectors:	AMP CPC type (mate supplied)
Motors:	115 VDC permanent magnet
Limit Switches	
Pan:	5 amp
Tilt:	5 amp External adjustment
Interference:	Electrical filtering to minimize starting and stopping glitches
Conductor Requirements:	6, unshielded (Functions: left, right, up, down, motor common, safety ground) (Variable speed, no additional conductors. For models with PP option, an additional 4 conductors are required.)

**GENERAL**

Construction: Aluminum plate; all internal parts corrosion protected  
Environment: Indoor/outdoor; completely weatherproofed  
Temperature: -10°F to 120°F (-23°C to 49°C)  
Dimensions: See Figure 7  
Weight: 22 lb (9.9 kg)  
Shipping Weight: PT550P/PP 25 lb (11.5 kg)  
All others 24 lb (10.87 kg)

*(Design and product specifications subject to change without notice.)*

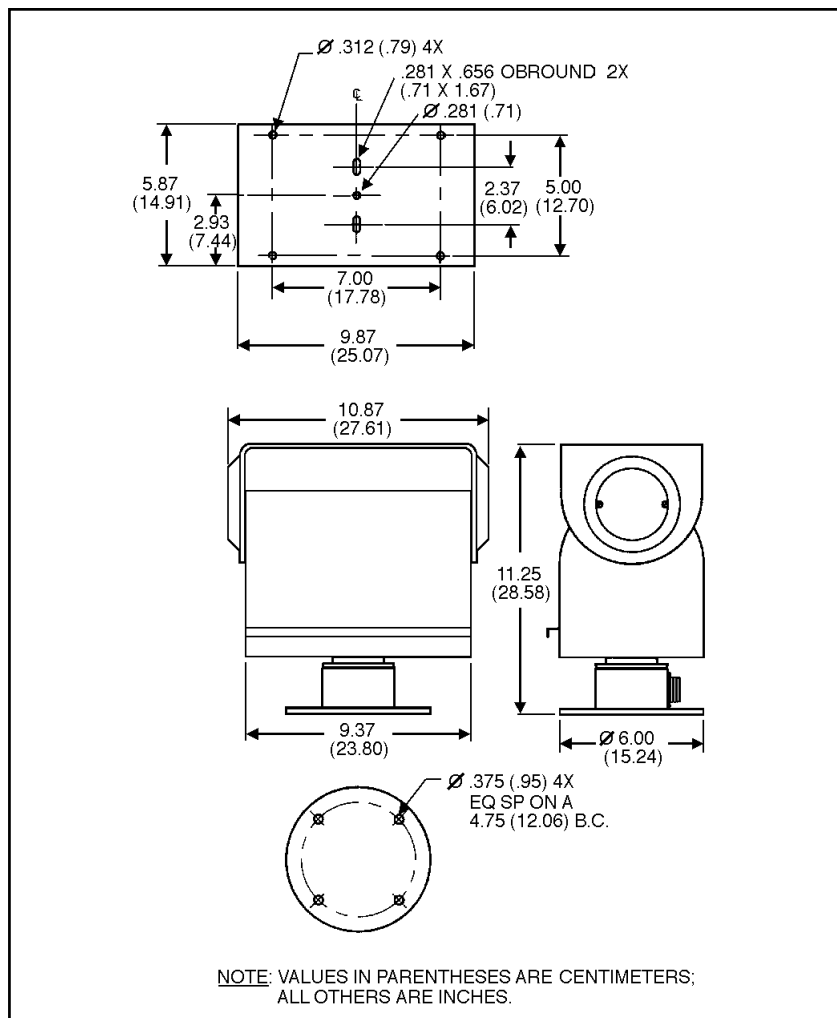

**Figure 7. PT550P Series Dimension Drawing**

---

---

## 8.0 WARRANTY AND RETURN INFORMATION

---

---

### WARRANTY

Pelco will repair or replace, without charge, any merchandise proved defective in material or workmanship for a period of one year after the date of shipment.

Exceptions to this warranty are as noted below:

- Five years on FT/FR8000 Series fiber optic products.
- Three years on Genex® Series products (multiplexers, server, and keyboard).
- Three years on Camclosure® and fixed camera models, except the CC3701H-2, CC3701H-2X, CC3751H-2, CC3651H-2X, MC3651H-2, and CC3651H-2X camera models, which have a five-year warranty.
- Two years on standard motorized or fixed focal length lenses.
- Two years on Legacy®, CM6700/CM6800/CM9700 Series matrix, and DF5/DF8 Series fixed dome products.
- Two years on Spectra®, Esprit®, ExSite™, and PS20 Scanners, including when used in continuous motion applications.
- Two years on Esprit® and WW5700 Series window wiper (excluding wiper blades).
- Eighteen months on DX Series digital video recorders, NVR300 Series network video recorders, and Endura™ Series distributed network-based video products. months on DX Series digital video recorders, NVR300 Series network video recorders, Endura™ Series distributed network-based video products, and TW3000 Series twisted pair transmission products.
- One year (except video heads) on video cassette recorders (VCRs). Video heads will be covered for a period of six months.
- Six months on all pan and tilts, scanners or preset lenses used in continuous motion applications (that is, preset scan, tour and auto scan modes).

Pelco will warrant all replacement parts and repairs for 90 days from the date of Pelco shipment. All goods requiring warranty repair shall be sent freight prepaid to Pelco, Clovis, California. Repairs made necessary by reason of misuse, alteration, normal wear, or accident are not covered under this warranty.

Pelco assumes no risk and shall be subject to no liability for damages or loss resulting from the specific use or application made of the Products. Pelco's liability for any claim, whether based on breach of contract, negligence, infringement of any rights of any party or product liability, relating to the Products shall not exceed the price paid by the Dealer to Pelco for such Products. In no event will Pelco be liable for any special, incidental or consequential damages (including loss of use, loss of profit and claims of third parties) however caused, whether by the negligence of Pelco or otherwise.

The above warranty provides the Dealer with specific legal rights. The Dealer may also have additional rights, which are subject to variation from state to state.

If a warranty repair is required, the Dealer must contact Pelco at (800) 289-9100 or (559) 292-1981 to obtain a Repair Authorization number (RA), and provide the following information:

1. Model and serial number
2. Date of shipment, P.O. number, Sales Order number, or Pelco invoice number
3. Details of the defect or problem

If there is a dispute regarding the warranty of a product which does not fall under the warranty conditions stated above, please include a written explanation with the product when returned.

Method of return shipment shall be the same or equal to the method by which the item was received by Pelco.

### RETURNS

In order to expedite parts returned to the factory for repair or credit, please call the factory at (800) 289-9100 or (559) 292-1981 to obtain an authorization number (CA number if returned for credit, and RA number if returned for repair).

All merchandise returned for credit may be subject to a 20% restocking and refurbishing charge.

Goods returned for repair or credit should be clearly identified with the assigned CA or RA number and freight should be prepaid. Ship to the appropriate address below.

If you are located within the continental U.S., Alaska, Hawaii or Puerto Rico, send goods to:

Service Department  
Pelco  
3500 Pelco Way  
Clovis, CA 93612-5699

If you are located outside the continental U.S., Alaska, Hawaii or Puerto Rico and are instructed to return goods to the USA, you may do one of the following:

If the goods are to be sent by a COURIER SERVICE, send the goods to:

Pelco  
3500 Pelco Way  
Clovis, CA 93612-5699 USA

If the goods are to be sent by a FREIGHT FORWARDER, send the goods to:

Pelco c/o Expeditors  
473 Eccles Avenue  
South San Francisco, CA 94080 USA  
Phone: 650-737-1700  
Fax: 650-737-0933

© Pelco, the Pelco logo, Spectra, Esprit, Genex, Legacy, and Camclosure are registered trademarks of Pelco.

™ Endura and ExSite are trademarks of Pelco.

© Copyright 1997, Pelco. All rights reserved.



## Free Manuals Download Website

<http://myh66.com>

<http://usermanuals.us>

<http://www.somanuals.com>

<http://www.4manuals.cc>

<http://www.manual-lib.com>

<http://www.404manual.com>

<http://www.luxmanual.com>

<http://aubethermostatmanual.com>

Golf course search by state

<http://golfingnear.com>

Email search by domain

<http://emailbydomain.com>

Auto manuals search

<http://auto.somanuals.com>

TV manuals search

<http://tv.somanuals.com>