

# PYLE<sup>®</sup> PRO<sup>®</sup> PDCD6000MP

**PROFESSIONAL DUAL CD MP3 PLAYER  
WITH SEAMLESS LOOP  
& SOUND EFFECT**

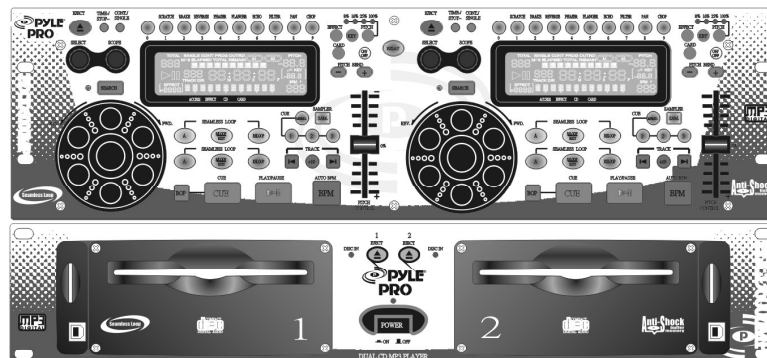

## INSTRUCTION MANUAL

# TABLE OF CONTENTS

<b>NOTE ON USE</b> .....	<b>2</b>
<b>FOR SAFE AND EFFICIENT OPERATION</b> .....	<b>2</b>
<b>DESCRIPTION OF THE FUNCTIONS</b> .....	<b>3</b>
FUNCTION OF THE MAIN UNIT.....	<b>3</b>
FUNCTION OF THE CONTROL UNIT.....	<b>4</b>
LCD INSTRUCTION .....	<b>6</b>
PARAMETER SETTING INSTRUCTION .....	<b>7</b>
CONNETIONS .....	<b>9</b>
<b>BASIC OPERATION</b> .....	<b>10</b>
LOADING AND EJECTING THE DISC.....	<b>10</b>
TRACK SKIP .....	<b>10</b>
ANTI SHOCK MEMORY .....	<b>11</b>
MATCHING THE BEATS PER MINUTE .....	<b>12</b>
BEAT MATCHING USING PITCH BEND.....	<b>12</b>
<b>OPERATION OF CUE AND LOOP</b> .....	<b>13</b>
<b>BEFORE SWITCHING OFF THE POWER</b> .....	<b>14</b>
<b>TROUBLESHOOTING GUIDE</b> .....	<b>14</b>

## NOTE ON USE

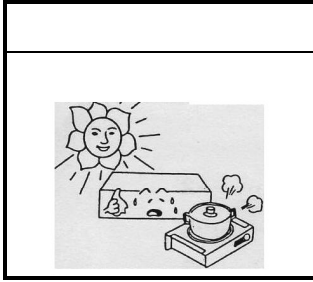

BE CAREFUL OF HIGH TEMPERATURE

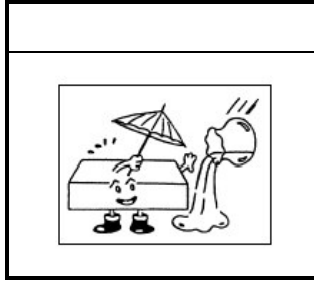

TO AVOID DUST & MOISTURE

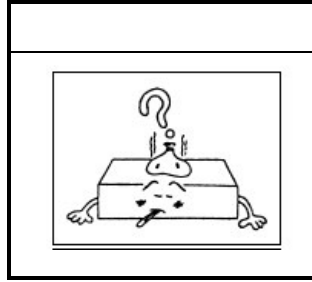

TO AVOID PLACING ON UNSTABLE LOCATION

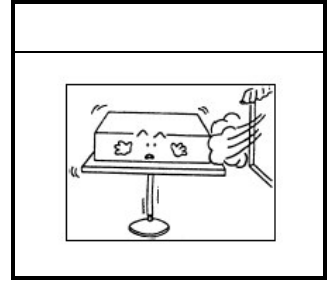

DO NOT USE CHEMICALS

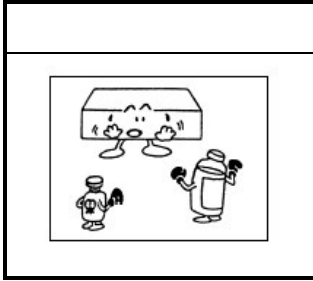

IF OUT OF WORK, CONTACT SALES AGENCY IMMEDIATELY

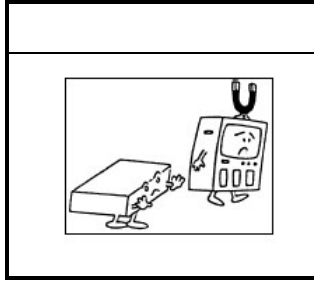

KEEP AWAY FROM TV & MAGNETISM

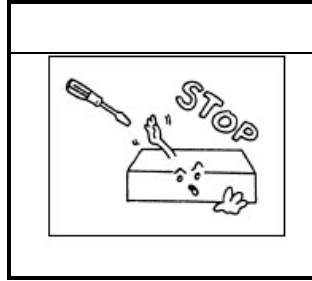

DO NOT OPEN THE CASE

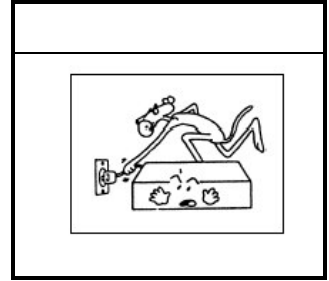

CARE WITH THE POWER CORD

### For Safe and Efficient Operation

- Select the installation location of your unit carefully. Avoid placing it in direct sunlight. Also avoid locations subject to vibration and excessive dust, heat, cold or moisture. Keep away from sources of hum such as transformers or motors.
- Do not use this compact disc player where there are extremes in temperature ( below 41 ° F/5 ° C or exceeding 95 ° F/35 ° C ).
- Do not open the cabinet as this might result in damage to the set or electrical shock.
- Be sure your hands are clean when handing discs. Never insert a disc which has a crack on its surface.
- When disconnecting the power cord from the AC outlet, always grasp it by the plug. Never pull the cord.
- Do not use force when operating the switches and buttons.
- Before moving the set, be sure to disconnect the power cord and all connecting cables.
- To keep the laser pickup clean, do not forget to close the disc tray.
- Do not attempt to clean the unit with chemical solvents as this might damage the finish. Use a clean, dry cloth.
- Keep this manual in a safe place for future reference.

### SAFETY CERTIFICATION

Laser Diode Properties  
 Material: Ga.-Al-As  
 Wavelength: 755-815 nm (25°C)  
 Laser Output: Continuous Wave max. 0.5mW

#### CAUTION:

*USE OF CONTROLS OR ADJUSTMENTS OR PERFORMANCE OF PROCEDURES OTHER THAN THOSE SPECIFIED HEREIN MAY RESULT IN HAZARDOUS RADIATION EXPOSURE.*

CAUTION

To prevent electric shock do not remove cover (or bottom screws). No user serviceable parts inside refer servicing to qualified servicing personnel.

## IMPORTANT SAFETY INSTRUCTION

1. Read these instructions.
2. Keep these instructions.
3. Heed all warnings.
4. Follow all instructions.
5. Do not use this apparatus near water.
6. Clean only with a damp cloth.
7. Do not block any of the ventilation openings. Install in accordance with the manufacturer's instructions.
8. Do not install near any heat sources such as radiators, heat registers, stoves, or other apparatus (including amplifiers) that produce heat.
9. Do not defeat the safety purpose of the grounding-type plug. A grounding type plug has two blades and a third grounding prong. The third prong is provided for your safety. When the provided plug does not fit into your outlet, consult an electrician for replacement of the obsolete outlet.
10. Protect the power cord from being walked on or pinched particularly at plugs, convenience receptacles, and the point where they exit from the apparatus.
11. Only use attachments/accessories specified by the manufacturer.
12. Use only with a cart, stand, tripod, bracket, or table specified by the manufacturer, or sold with the apparatus. When a cart is used, use caution when moving the cart/apparatus combination to avoid injury from tip-over.
13. Unplug this apparatus during lightning storms or when unused for long periods of time.
14. Refer all servicing to qualified service personnel. Servicing is required when the apparatus has been damaged in any way, such as power-supply cord or plug is damaged, liquid has been spilled or objects have fallen into the apparatus, the apparatus has been exposed to rain or moisture, does not operate normally, or has been dropped.



## DESCRIPTION OF THE FUNCTIONS

### Function of the Main Unit :

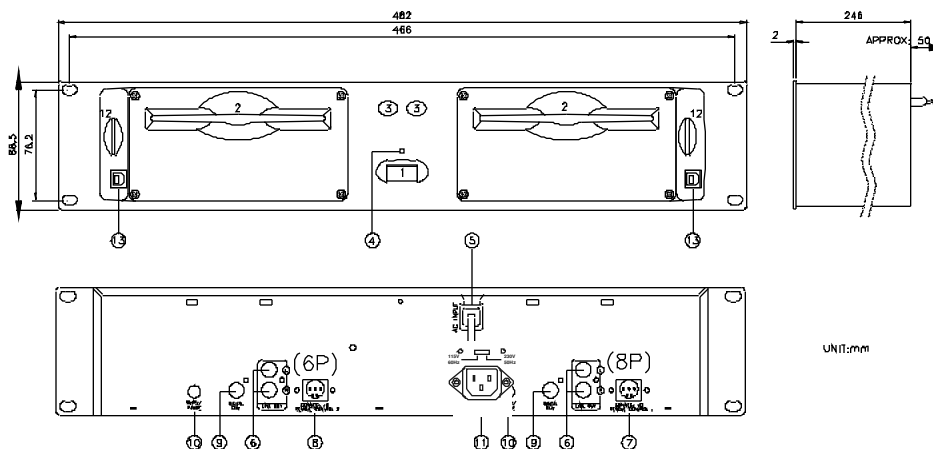

#### 1. POWER (Power Switch)

Press the power switch to turn the unit on, and the LED indicator will be light. To switch the POWER off by pressing the POWER switch again.

#### 2. DISC SLOT

Insert and remove the disc.

#### 3. EJECT BUTTON

Press to eject the disc.

**NOTE:** Disc won't be ejected unless stop or pause button has been push first.

#### 4. DISC INDICATOR

It lights up after loading the disc.

#### 5. AC INPUT

Connecting this power cord into an AC wall outlet with the proper AC voltage.

#### 6. LINE OUT (Output Jacks)

The audio from each CD player is output from these jacks. Connect to the line input of the mixer.

#### 7. CONNECTOR PORTS

The 8-pin termination permits the connection of the main unit to the control unit 1.

#### 8. CONNECTOR PORTS

The 6-pin termination permits the connection of the main unit to the control unit 2.

#### 9. DIGITAL OUT

The digital from each CD player is output from these jacks. Connect to the line input of the D/A Amplifier.

#### 10. START/PAUSE

This connector is used for fader start; connect it to a mixer, and remote control the "START/PAUSE" by moving the fader of mixer.

#### 11. TACT-LOCK option

Select the type of switch in the mixer for FADERSSTART wire remote control.

#### 12. MEMORY CARD SLOT (OPTION)

Load SD card for playback or copy MP3 audio file from computer through USB cable.

- Insert Card: Press the card to the slot gently. On the display, the mark ▼ above CARD lights up.
- Remove Card: Draw out the card, the mark ▼ above CARD is off.
- Loading MP3 file: During writing data to the card, the display will show "PC LINK", and all function keys are locked, only the EJECT key is workable.

#### 13. USB PORT (OPTION)

Connect to a computer's USB connector with USB cable. USB Driver disc is attached for installing the driver program, it's designed to work with Microsoft Windows 98/Me/2000/XP.

## Function of the Control Unit

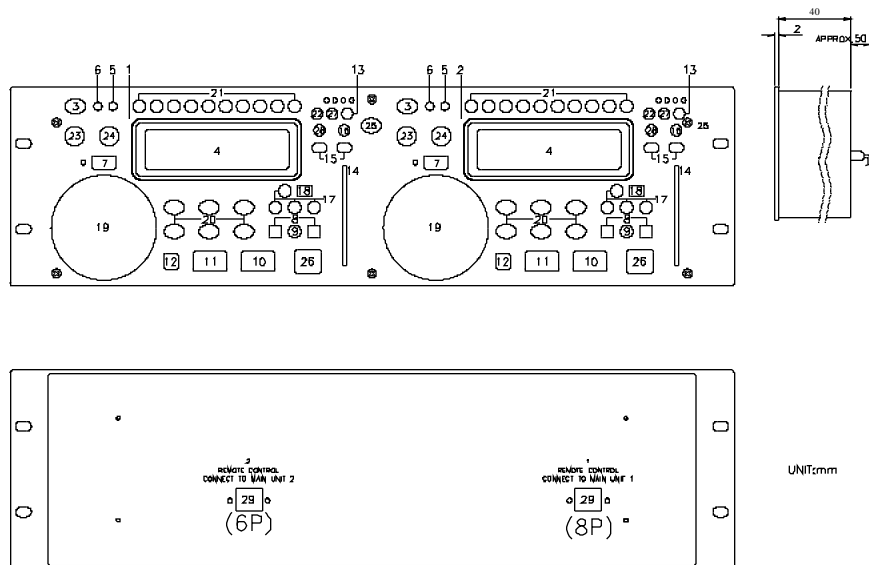

### 1. UNIT 1-CONTROL OPERATION PANEL

This operation panel remotely controls the main unit 1.

### 2. UNIT 2- CONTROL OPERATION PANEL

This operation panel remotely controls the main unit 2.

### 3. EJECT BUTTON

Press to eject the disc.

**Note:** Disc can't be ejected unless the stop or pause button has been pushed first.

### 4. MATRIX L.C.D

Display the details of music data, please refer to the LCD instruction (page 6)

### 5. CONT /SINGLE BUTTON ( OUTRO)

To press this button it can switch between auto cue single and continue. The selected mode is indicated on the display.

\*AUTO CUE SINGLE - After each track, the unit pauses at the beginning of next track. The playback starts from audible point.

\*CONTINUE -To play all tracks continually.

\*OUTRO - The unit will play the last 30 seconds of each track. Press the button for 3 seconds to switch OUTRO function.

**Note:** OUTRO is not available for MP3 music.

### 6. TIME / STOP BUTTON

This button switches the time display between total remaining time, each remaining time and elapsed playing time. The unit will be in the "stop" mode if you continue pressing the button for 3 seconds.

### 7. SEARCH BUTTON

Pressed the button to switch the function of Jog Dial between SEARCH and PITCH BEND.

- When the indicator LED is light, dial the jog for quick search forward and backward.
- When the indicator LED is off, dial the jog for pitch bend function.
- If the jog is unmoved for 8 seconds, the indicator is off, and the jog is for pitch bend function.

### 8. TRACK BUTTON

These buttons select the track to be played.

### 9. +10 BUTTON

Pressed the button to forward 10 tracks. If you forward 10 tracks, and the tracks over total tracks, the unit will jump to track 1...

### 10. PLAY/ PAUSE BUTTON

Each press of this button causes the operation to change between PLAY and PAUSE modes.

### 11. CUE BUTTON

The cue function allows the CD returning to the memorized point. In PAUSE mode, pressing the CUE button to set the cue point, and the CUE button blinks; in PLAY mode, press this button to pause the unit at the memorized point.

### 12. BOP BUTTON

The playback will automatically play from the CUE point upon the button is pressed.

### 13. PITCH BUTTON

Select the pitch change range from  $\pm 8\%$ ,  $\pm 16\%$ ,  $\pm 32\%$ ,  $\pm 100\%$ . The playback speed will change when you move the pitch control slider.

### 14. PITCH CONTROL SLIDER

To match the choices of playback speed (8%, 16%, 32%, 100%), you can choose what range you want between minimum (up side) and maximum (bottom side) by moving the pitch control slider.

### 15. PITCH BEND + / - BUTTON

When each of the two CD players is playing, the pitch bend function allows the position of the bass beat to be matched after the pitch has been adjusted. The pitch will automatically rise up to + 16% from the current setting while pressing the "+ "button. While pressing the "- " button, the pitch will automatically drop to - 16 % from current setting. By the way of changing the pitch the position of the beats can be matched.

## 16. ON/OFF BUTTON (PITCH)

Press the button to be PITCH ON mode, press it again on the PITCH ON mode, and blinks with unit on the PITCH OFF mode.

## 17. 3 HOT-CUE

This unit will allow you to play from 3 cue points instantly.

a. Set CUE memory: Press the MEMO button first, and then press the CUE button to complete the CUE setting, then this CUE button will light up.

b. Play "CUE" memory: Upon pressing specific CUE button, it will flash about 5 seconds.

**Note: This function is not available during perform REVERSE sound effect.**

## 18. SAM. BUTTON

Sampler is a kind of sound effect that you record the music from the track. While playing the music, you can use the sampler to mix with music. The maximum length is 32 seconds.

a. Set start point: Press the MEMO key, and then press SAM button, after memorizing the SAM button flashes quickly (2 times in 1 sec)

b. Set End point: Press the SAM button again, when the end point is memorized, the SAM button lights up (not flash).

c. Play Sampler: During PLAY mode, press the SAM button, then the button will flash slowly. (1 time in 1 sec)

**NOTE: Refer to parameter setting instruction for sampler adjustment**

## 19. JOG WHEEL

### \*Speed Control (SEARCH indicator off)

Rotating the wheel, in play mode, will change the playback speed accordingly. While rotating clockwise, the player speed increase; rotating counterclockwise, the speed decrease.

### \*Search (SEARCH indicator lights)

Rotating the wheel, the player will forward or backward quickly. The searching speed changed according to the dialing speed. It can be carried out by one frame increment.

## 20. Seamless Loop (2 set)

There is A, B/LOOP/EXIT, RELOOP buttons.

1. A BUTTON--"start point" (A point. Also, Cue 1 could be A point) After setting up the A point, the red Led light up
2. B/LOOP/EXIT BUTTON: --" End point"(B point). Press the B /LOOP button to set up the B point and start the loop playback automatically. Loop lights on the display and the 3 LEDs flash. Press this button again to exit the LOOP playback
3. Return to the loop playback by pressing the RELOOP while in performance. However, if your want to return to loop playback, you can press RELOOP BUTTON
4. Change " START POINT" and" END POINT" by pressing the A& B/LOOP/EXIT button again
5. The interval between A and B point must be more than 20 frames; otherwise, the B point will be canceled, then LOOP function disappear and LOOP fades on the display

## 21. SOUND EFFECT/ DIRECT ACCESS BUTTONS

### \* SOUND EFFECT OFF

The buttons are direct access keys (0~9). To select the number of the track you would like to play.

### \* SOUND EFFECT ON

The buttons is for sound effect control and it lights up when the sound effect be chosen and off when the button is pressed again.

**NOTE:** How to set up the parameter; please refer to parameter setting instruction. (Page 7)

**SCRATCH:** Move the JOG Wheel backward or forward like scratching a turntable record. This sound effect can be performed independently, or in parallel with other effect.

**BRAKE:** To change the speed of PAUSE and START. This sound effect can be performed independently, or in parallel with other effect.

**REVERSE:** The music is playing backward. This sound effect can be performed independently, or in parallel with other effect.

**PHASER:** It sounds like the airplane takes off

**FLANGER:** It sounds like another kind of airplane takes off. .

**FILTER:** There are bass & treble. To increase the parameter value, it will cut bass off but keep treble. To decrease the parameter value, it will cut treble off but keep bass.

**CHOP:** The music is chopped with break.

**PAN:** Alternaty playing right and left signal

**ECHO:** Have the effect as ECHO.

## 22.SOUND EFFECT ON/OFF SWITCH

Press the EFFECT button to activate or deactivate the sound effect. While the effect is activated, on the display the mark ▼ above the effect is light. .

## 23.EFFECT SELECT KNOB

The parameter of sound effect can be pre-set. Turn the knob until the LCD shows the effect name that you want, push the button to select it, and turn this button again to select from the menu for setting parameter.

## 24.EFFECT SCOPE KNOB

After the menu of effect is selected, turn this knob to choose the parameter, the relative value can be shown in the LCD.

(Please refer to page 7 with the Parameter Setting Instruction for details)

When the unit is not under parameter adjustment, the display does not show the effect name, this knob can be used to adjust the KEY scale, and press it to lock the key (the display will show )

## 25.RELAY

Press the "RELAY" button to activate. When one unit is in play mode, and the other unit is in "pause" mode; pause the playing unit, the other unit will automatically start to play (the button will blink).

## 26.BPM BUTTON

You can get the BPM number automatically or manually. Pressing the BPM BUTTON for 3 seconds to switch between auto and manual control. The BEAT will be shown on the display! Under the manual mode, tapping this button to get the beat value.

## 27.KEY ON/OFF SWITCH

Press the button to switch KEY mode on or off.

●KEY OFF: The display shows the "KEY" in blinking, and the key changed according to the pitch change. The key parameter adjustment is not in effect

●KEY ON: The "KEY" lights on the display, turning the SCOPE knob to adjust the key. Slide the pitch slider will also change the key.

●KEY LOCK: Press the SCOPE knob to lock the key as set, sliding the pitch slider does not change the key. Please refer to parameter setting instruction. (Page 8)

**28.CARD:** Switch the playback source to memory card.

## 29.CONNECTOR PORT

The 8-pin(6-pin) termination permits the connection of the control unit to the main unit.

## 30.SLEEP:

Leave the unit unused for 30 minutes; the machine will shut off automatically.

# LCD INSTRUCTION

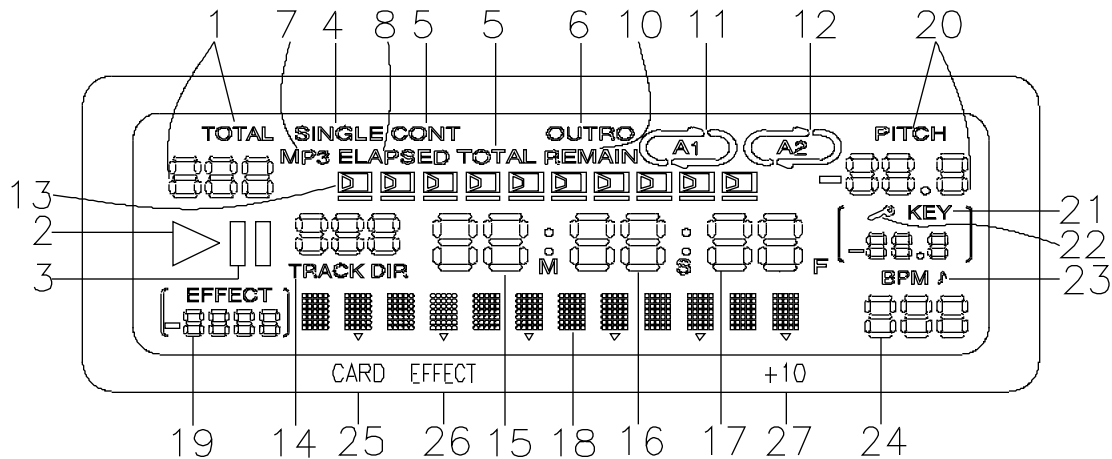

1. **TOTAL TRACK** – the track number of the CD or CARD.
2. – The unit is in playing.
3. – The unit is paused
4. **SINGLE** – Shows when the unit is set to play only one track.
5. **CONT** – Shows when the unit is set to play the all tracks continually.
6. **OUTRO** – Shows when the unit is set to play the last 30 seconds of each track.
7. **MP3** – Lights up when the unit is playing MP3 file.
8. **TIME MODE (ELAPSED)** – Shows the time as it is taking place.
9. **TIME MODE(TOTAL)** – Shows how much time is left on full CD, but not for MP3 CD.
10. **TIME MODE (REMAIN)** – Shows how much time is left on a particular track.
11. – A1 lights up after setting up start point(A point). A1 and flash after setting end point (B point) and start the loop playback automatically. A1 and light up after exiting the LOOP playback and in performance.
12. – Refer to SEAMLESS LOOP A1.
13. **TIME BAR** – Show the time length depending on the setting of the "TIME" mode.
14. **TRACK** – Shows the track number that is playing.
15. **MINUTES** – Shows the minutes elapsed or remaining depending on mode setting.
16. **SECONDS** – Shows the seconds elapsed or remaining depending on mode setting.
17. **FRAMES** – The CD Player breaks down a second into 75 frames for accurate cueing. This shows the frames elapsed or remaining depending on mode setting.
18. **EFFECT MODE DISPLAY** – Shows the effect name selected in effect parameter setting mode and shows the song name in performance.
19. **THE PARAMETER OF SOUND EFFECT**
20. **PITCH** – The pitch change range
21. **KEY** – Lights up when key effects are active and indicates key position, otherwise it flash.
22. – Lights up when key has been locked.
23. **BPM**: Manual ; : Auto
24. **Number of Beat per minute**
25. **CARD** – Lights up when the unit is reading SD card. (OPTION FUNCTION)
26. **EFFECT** – Lights up when the EFFECT function is on.
27. **+10** – Lights up and indicate the scope value of effect parameter to be adjusted 10 units each time.
28. **LOADING MP3**: During writing data to the card, It will show "PC LINK". (OPTION FUNCTION)

## PARAMETER SETTING INSTRUCTION

Effect	Menu	Note	Default	Scope
BRAKE	BK/START_T	1	20 (1 unit = 0.1 sec)	0 ~ 100 (0.1 ~ 10 sec)
	BK/STOP_T	2	20 (1 unit = 0.1 sec)	0 ~ 100 (0.1 ~ 10 sec)
PHASER	PS/BPM_SYNC	3	ON	ON / OFF
	PS/GAIN	4	50 (%)	0 ~ 100 (%)
	PS/TIME	5	SYNC OFF: 50 (1 unit = 0.01 sec)	25~800 (0.25 ~ 8 sec)
SYNC ON: 4/1 beat			1/4 ~ 64/1 beat	
FLANGER	FG/BPM_SYNC	6	ON	ON / OFF
	FG/GAIN	7	40 (%)	1 ~ 90 (%)
	FG/TIME	8	SYNC OFF: 50 (1 unit=0.01sec)	25 ~ 800 (0.25 ~ 8 sec)
SYNC ON: 4/1 beat			1/4 ~ 64/1 beat	
ECHO	EC/BPM_SYNC	9	ON	ON / OFF
	EC/GAIN	10	50 (%)	0 ~ 100 (%)
	EC/DELAY_LG	11	SYNC OFF: 50	1 ~ 400
SYNC ON: 4/1 BEAT			1 ~ 4/1 beat	
FILTER	FL/BPM-SYNC	12	ON	ON/OFF
	FL/SCAN_TIME (FL/BPM-SYNC:ON)	13	8/1 BEAT	1/4 ~ 64/1 BEAT
	FL/FREQUENCY (FL/BPM-SYNC:OFF)	14	50	0 ~ 100
	FL/GAIN	15	40	0 ~ 100
PAN	PAN/BPM_SYNC	16	ON	ON/OFF
	PAN/MIX	17	100 (%)	1 ~ 100 (%)
	PAN/PERIOD	18	SYNC OFF: 50 (1unit = 0.01sec)	6 ~ 400 (0.06 ~ 4 sec)
SYNC ON: 1/1 beat			1/64 ~ 4/1 beat	
CHOP	CP/BPM_SYNC	19	ON	ON / OFF
	CP/WIDTH	20	50 (%)	0 ~ 100 (%)
	CP/PERIOD	21	SYNC OFF: 50 (1unit = 0.01sec)	6 ~ 400 (0.06 ~ 4 sec)
SYNC ON: 1/1 beat			1/64 ~ 4/1 beat	
SAMPLE	SPL/MIX_VOL	22	50 (%)	0 ~ 100 (%)
	SPL/PITCH	23	0 (%)	±100 (%)
	SPL/LOOP_SW	24	OFF	ON/OFF
	SPL/RESERVE	25	OFF	ON/OFF
	SPL/INSERT	26	OFF	ON/OFF
KEY	KEY_SEMITONE	27	ON	ON: +12 ~ -24 key
				OFF: -100% ~ + 100%



# PARAMETER SETTING INSTRUCTION

## NOTE :

1. **BK/START\_T** : The period time before starting music
2. **BK/STOP\_T** : The period time before stopping music
3. **PS/BPM\_SYNC**: Add the PHASER effect to the music in a cycle based upon the selected beat
4. **PS/GAIN**: Determine the volume of PHASER effect signal. The higher ratio with stronger effect.
5. **PS/TIME**: Determine the length of PHASER effect. SYNC-OFF, 0.25 sec is the shortest, and 8 sec is longest; SYNC\_ON, 1/4 beat is the shortest and 64 beats is the longest.
6. **FG/BPM\_SYNC**: Add the FLANGER effect to the music in a cycle based upon the selected beat
7. **FG/GAIN**: Determine the volume of FLANGER effect signal. The higher ratio with stronger effect.
8. **FG/TIME** : Determine the length of FLANGER effect. SYNC-OFF, 0.25 sec is the shortest, and 8 sec is longest; SYNC\_ON, 1/4 beat is the shortest and 64/1 beats is the longest.
9. **EC/BPM\_SYNC**: Add the ECHO effect to the music in a cycle based upon the selected beat
10. **EC/GAIN**: Determine the volume of ECHO effect signal. The higher ratio with stronger effect.
11. **EC/DELAY\_LG**: The delay time of ECHO effect. SYNC OFF, 0.01 sec is the shortest, and 4 sec is longest; SYNC\_ON, 1 beat is the shortest and 4/1 beats is the longest.
12. **FL/BPM-SYNC**: Add the FILTER effect to the music in a cycle based upon the selected beat
13. **FL/SCAN\_TIME (FL/BPM-SYNC:ON)**: Determine the scanning time of FILTER effect. 1/4 beat is the shortest and 64/1 beats is the longest
14. **FL/FREQUENCY(FL/BPM-SYNC:OFF)** : Select the band of frequency. The number increased, The frequency is close to the treble. The number decrease, The frequency is close to bass.
15. **FL/GAIN**: Determine the volume of FILTER effect signal. The higher ratio with stronger effect.
16. **PAN/BPM\_SYNC**: Add the PAN effect to the music in a cycle based upon the selected beat
17. **PAN/MIX** : Determine the volume of signal taken for mixing to the other side.
18. **PAN/PERIOD**: Determine the period of PAN effect. SYNC-OFF, 0.06 sec is the shortest, and 4 sec is longest; SYNC\_ON, 1/64 beat is the shortest and 4/1 beats is the longest.
19. **CP/BPM\_SYNC**: Add the CHOP effect to the music in a cycle based upon the selected beat
20. **CP/WIDTH** : Determine the ratio of audible music, the higher ratio with more audible signal.
21. **CP/PERIOD** : Determine the period of CHOP effect. SYNC-OFF, 0.06 sec is the shortest, and 4 sec is longest; SYNC\_ON, 1/64 beat is the shortest and 4/1 beats is the longest.
22. **SPL/MIX\_VOL**: The ratio of SAMPLE single mixing into the music.
23. **SPL/PITCH**: To select the sample pitch range from -100% to +100%, 0% means sample playback speed is unchanged.
24. **SPL/LOOP\_SW**: To play the sample music repeatedly
25. **SPL/REVERSE**: To play the sample music backward to mix with music.
26. **SPL/INSERT** : To cut off the music and insert the sample music.
27. **KEY\_SEMITONE** : SEMITONE\_ON, to change the key by half step, from +12 to -24 key; SEMITONE\_OFF, change the key by percentage from -100% to +100%.

# Connections

Typical connections with a mixer is illustrated below. Please use it for reference.

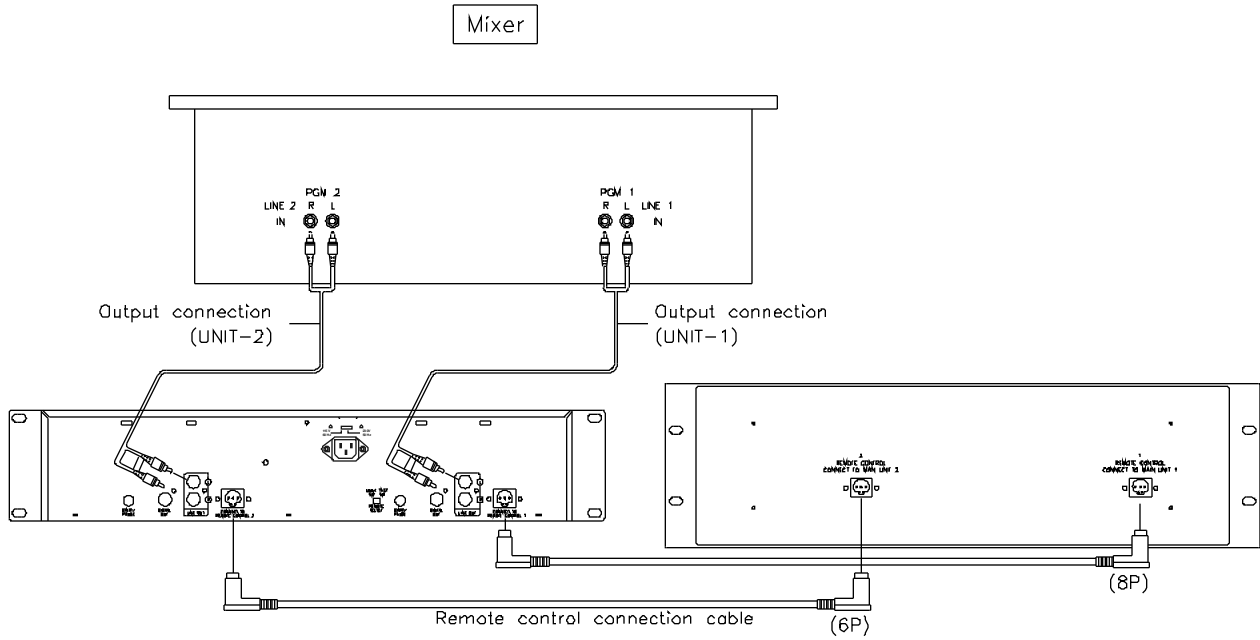

- \* Connect the connection cords to the line inputs of your mixer.
- \* The connection cords and the remote control connection cable are supplied with the main unit.
- \* Be sure to use the remote control connection cable which has been supplied. Use of another cable type might cause damage.

# BASIC OPERATION

## Loading and Ejecting the Disc

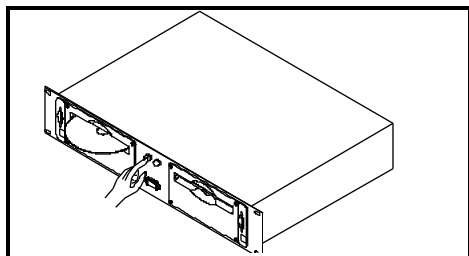

When the disc is loaded, press the EJECT button to eject the disc (This may be done on either the player or the remote control side.)

Place a disc in the disc loader

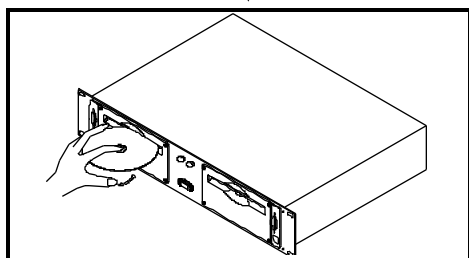
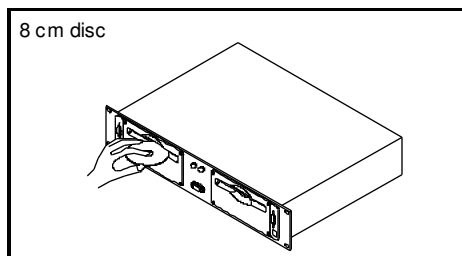
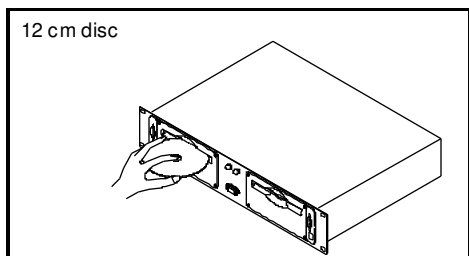

Push the disc to the loader.

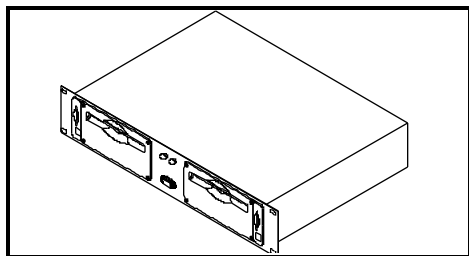

While the disc is loaded, the preparation for disc play will begin.

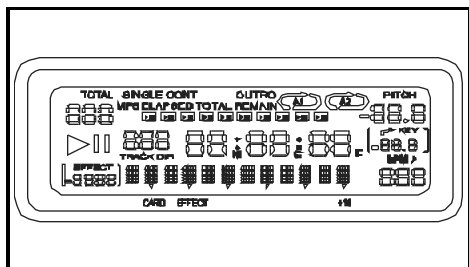

When preparation is completed, the total tracks number & total playing time will display.

To the desired track

## TRACK SKIP

To go back through the tracks

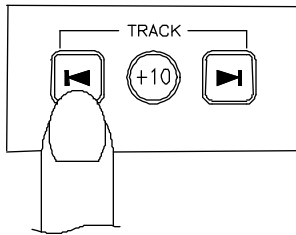

Tracks change as follows  
(This is for a disc containing 4 tracks)

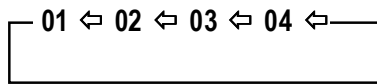

When this button is pressed once, the CD player will skip backward to the beginning of the track, press twice will skip backward to the previous track.

To advance through the tracks

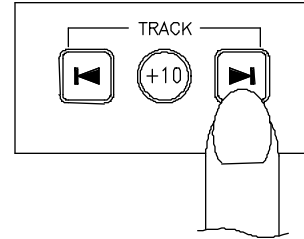

Tracks change as follows

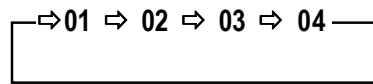

When this button is pressed once, the CD player will advance to the beginning of the next track.

## ANTI SHOCK MEMORY

This CD Player is equipped with an anti-shock memory, which memorizes 10 seconds of music before reading, to be not in case of shock.

**Warning:** This system can't work in case of repetitive shocks or vibrations and if the memory is not completely charged.

# MATCHING THE BEATS PER MINUTE

Match the pitch by monitoring the music of both UNIT 1 and UNIT 2 by ear. When the tempo of the music of the selected CD player is slow compared to the tempo of the other player, move the slider to the + side and match the tempo. When fast, move to the - side.

The following description is for the case of matching the pitch of UNIT 2 to the pitch of the music being played on UNIT 1.

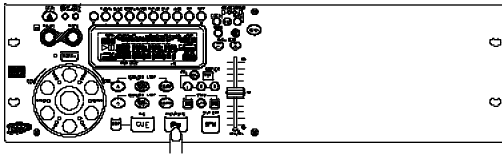

UNIT 1 is playing.

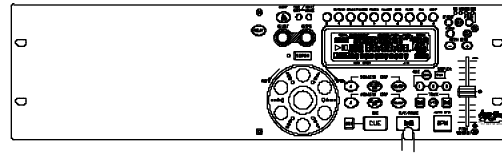

Press PLAY/PAUSE to start UNIT 2.

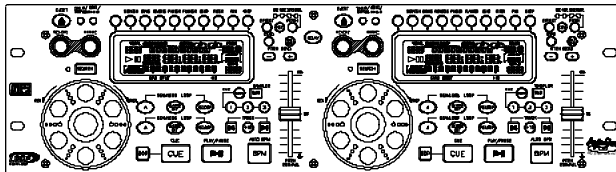

Both CD players are playing discs.  
Listen to UNIT 2 in your headphones.

When UNIT 2 is slow compared to UNIT 1

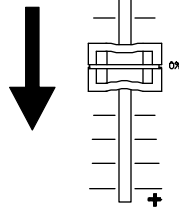

When UNIT 2 is fast compared to UNIT 1

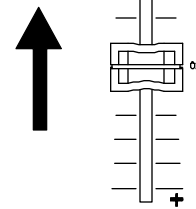

# Beat Matching Using Pitch Bend

A description of the procedure for matching the beat of UNIT 1 and UNIT 2 using the PITCH BEND stick is given below.

This description is for the case of matching the beat of UNIT 2 to the beat of the music being played on UNIT 1. (This procedure can be done on either Unit).

After Matching the BPM's

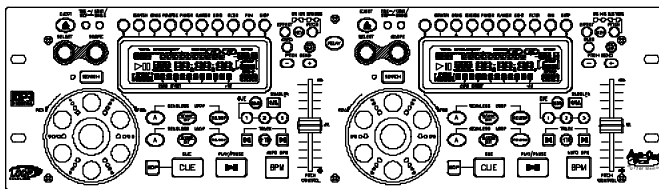

BPM's (Beat Per Minute) are the same, however the bass beats are not matched.



When UNIT 2 is ahead.

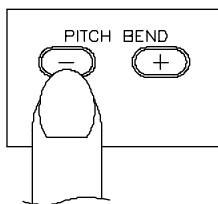

When UNIT 2 is behind.

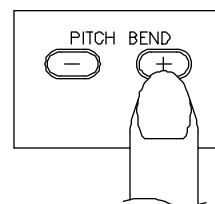

## OPERATION OF CUE (WITH PLAY/PAUSE)

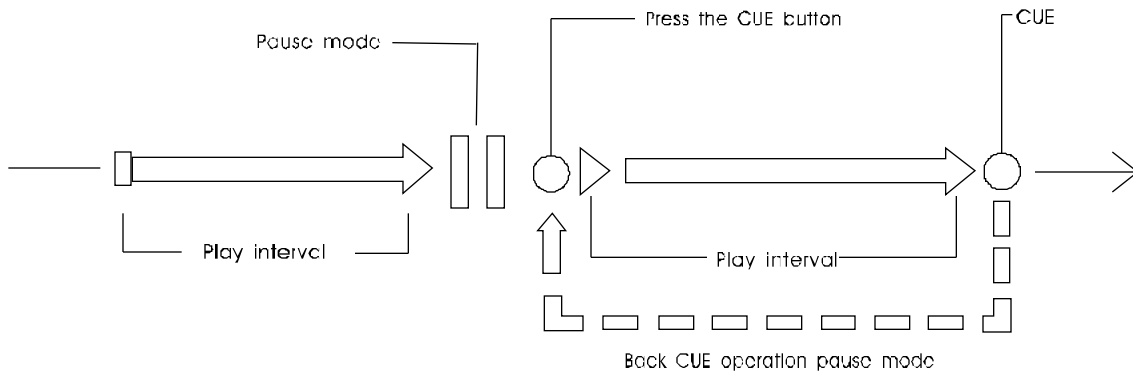

1. In pause mode, press CUE button to memorize a point for playing back. We mean it "cue point".
2. After "cue point" is memorized, in play mode, pressing CUE button will return the music back to the cue point and keep it in pause mode.
3. Press PLAY button again to perform from "cue point".

## OPERATION OF A AND B/LOOP

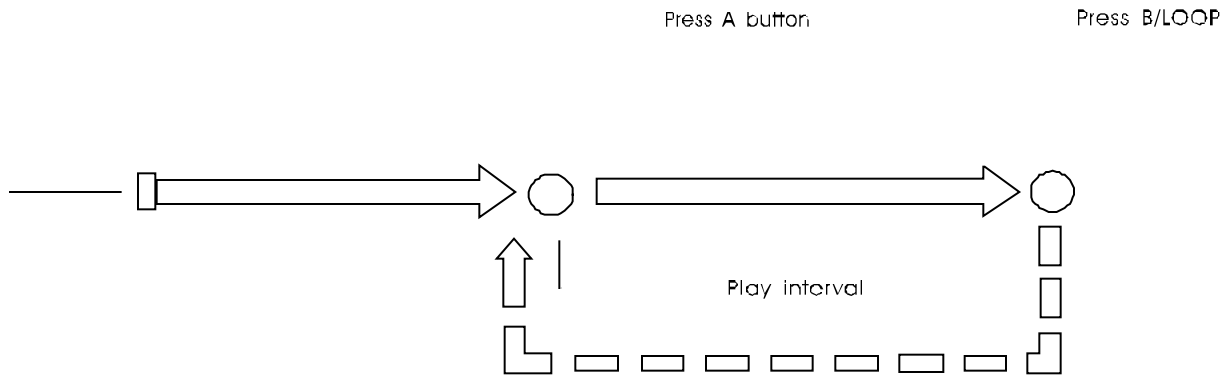

1. Set "A POINT" under play mode by pressing A button (without interruption during playback).
2. Press B/LOOP to memorize the ending point of loop, we mean it "B POINT". At the meantime, it blinks **LOOP** on the LCD, and the music automatically comes back to "A POINT" and loops between A & B points.
3. While the music loops between A & B, press **B/LOOP EXIT** to leave the loop. At the meantime, it lights **LOOP** on the LCD.
4. Press RELOOP again during playback, it returns the loop function.
5. Within play interval, you can change "A POINT" & "B POINT" by pressing A & B/LOOP button under play mode.
6. Also available to change "start point" by pressing A button in pause mode during loop function.

## BEFORE SWITCHING OFF THE POWER

When you have finished using the CD player, before switching off the power, ensure that the disc is ejected

**X**

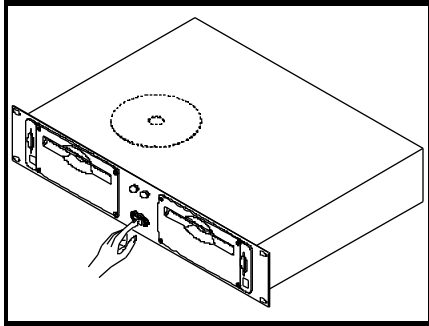

Do not switch off the power when the disc is in the loader.

**POWER OFF**

**O**

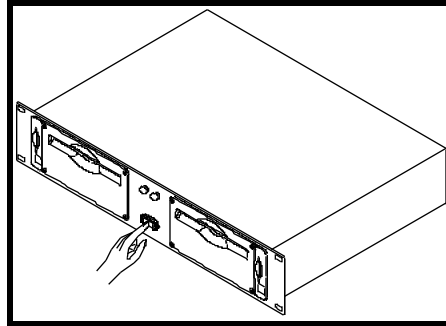

Switch off the power after the disc is ejected.

**POWER OFF**

## TROUBLESHOOTING GUIDE

If difficulties arise with your compact disc player, locate the apparent problem in the left-hand column of the table and follow the corrective action suggested in the right-hand column.

1. Is the compact disc player properly connected to the amplifier?
2. Is the amplifier set for the proper operation?
3. Have the operating instructions for the compact disc player been followed?

Symptom	Possible Cause	Corrective Action
The power fails to switch on when the POWER switch is set to ON	Poor power plug connection at the AC outlet.	Insert the power plug firmly into the AC outlet.
Disc play does not start	The disc is loaded upside down. The disc is too dirty.	Reload the disc with the label side up. Clean the disc.
No sound	Improper output cable connections. Improper amplifier operation.	Connect the output cable properly. Make sure that the amplifier controls are set properly.
Sound skips	The CD player is subject to vibrations or physical shock.	Change the installation location.
Hum	Loose cable connections.	Firmly connect all audio plugs.

# USB Driver Installation and Operating Instructions

For running program properly, please install the Driver before installing the Application program

## I. The driver Setup

1. There are three directories on installation CD, please select the Driver directory.
2. Run setup.exe and finish installation of the driver.
3. Please press YES to reboot the computer, if operating system is Win98 or Win ME. Please press No to neglect this step, if operating system is Win 2000 and Win XP.

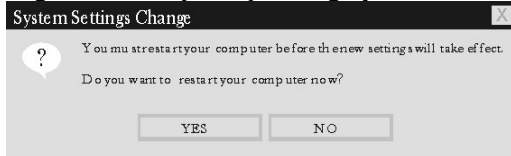

4. Connect the CD player and computer with USB cable before switching on CD player.
5. Switch on the CD player.
6. When Windows detects your CD player, the New Device Found dialog box appears.



7. Please select Driver directory on installation CD



8. Follow the on screen instructions to complete the setup (The warning box will appear, if operating system is Win XP. Don't worry and continue setup.)
9. Continue setup the application program after installation of the driver finishes.



## II. Application Setup

1. There are three directories on installation CD. Please select the DJMP3 directory.
2. Follow the onscreen instructions to complete the setup.
3. Run DJMP3 program on START menu after finishing application installation.

## III. Application instructions

- ◇ The files in SD card will automatically be listed in SD card box after running application program.
- ◇ Drag selected files to file list box and release, the selected files will be added to file list box.
- ◇ Select the files in SD card box first and press DELETE button, if you would like to delete the files in SD card.
- ◇ Select the files in file list box first and press DELETE button, if you would like to delete the files in file list box.
- ◇ The selected file in file list box will be downloaded to SD card after pressing download button, programming percentage will be showed in the programming bar.
- ◇ The description of DJMP3 functions
  - ◆ Before copying, please follow the steps described below:
    - i. Connect the USB cable
    - ii. Open the DJ-MP3 program
    - iii. When the dialogue box shows “please insert SD card”, insert the SD card into the memory card slot and press the “OK” on the screen.
  - ◆ DJ-MP3 instruction

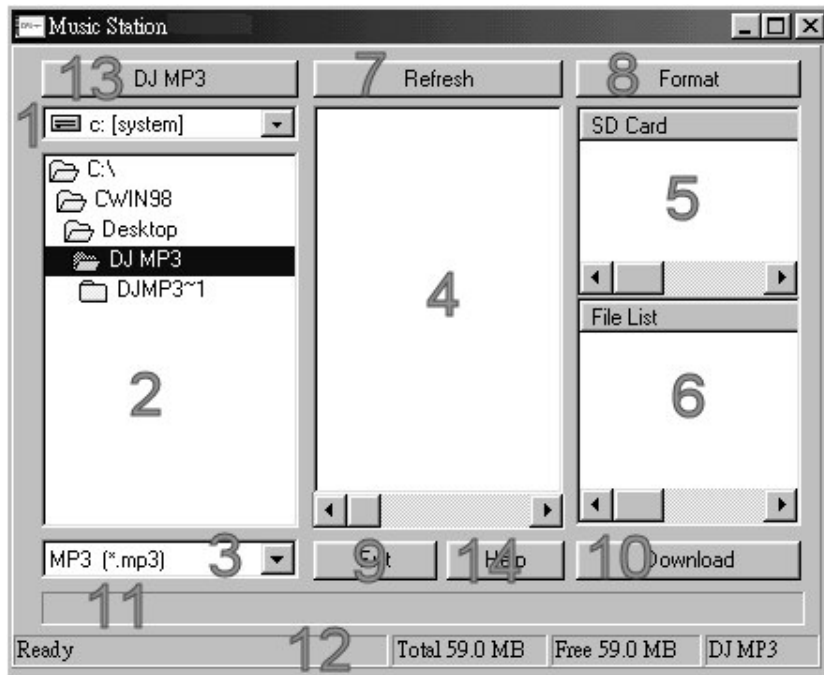

1. The drive box: Show the selected drive.
2. The directory box: Show the selected directory.
3. The file type box: Select the type of file you would like to show.
4. The file box: Show the files in selected directory.
5. The SD card box: Show the files in SD card.
6. The file list box: Show the files to be downloaded to SD card.
7. The refresh button: Refresh ID information of SD card. To avoiding program crash, Please press the refresh

button after you changed SD card.

8. The format button: Format SD card, and all the file will be deleted. If the SD card is fresh, format it before the first use.
9. The exit button: Exit the application program.
10. The download button: Press this button to download files to SD card.
11. The progress bar: Show the downloading progress.
12. The status bar: Displays the total and remaining space of SD card showed in status bar.
13. DJ MP3: Press the button to get the information about the DJMP3 program.
14. Help: Provide help and instruction for the DJMP3 program.

## **IV. Operation Environment for running DJ/MP3 program**

- PC: IBM PC/AT or compatible, with 933 MHz or faster Intel® Pentium® III processor
- Memory: At least 128MB must be mounted
- Hard disc: At least 25MB of memory must be available during installation
- Disc drive: Must support CD-ROM and CD-DA playback
- Display: Resolution of at least 800 \* 600 pixels (SVGA)/high color (16 bits)
- Operating system: Microsoft® Windows® 98SE/ME/2000/XP
- External port: USB 1.1 or later version USB ports

### **NOTE**

1. MPEG Layer-3 audio decoding technology licensed from Fraunhofer IIS-A and Thomson multimedia.
2. The SD logo is trademark. Portions of this product are protected under copyright law and are provided under license.
3. Microsoft & Windows are trademarks of Microsoft Corporation in the United States and other countries
4. Pentium is a registered trademark of Intel Corporation.
5. This unit is not to be used for illegal purpose.

## Free Manuals Download Website

<http://myh66.com>

<http://usermanuals.us>

<http://www.somanuals.com>

<http://www.4manuals.cc>

<http://www.manual-lib.com>

<http://www.404manual.com>

<http://www.luxmanual.com>

<http://aubethermostatmanual.com>

Golf course search by state

<http://golfingnear.com>

Email search by domain

<http://emailbydomain.com>

Auto manuals search

<http://auto.somanuals.com>

TV manuals search

<http://tv.somanuals.com>