

USER GUIDE

DT Chassis Industrial Printers/Plotters

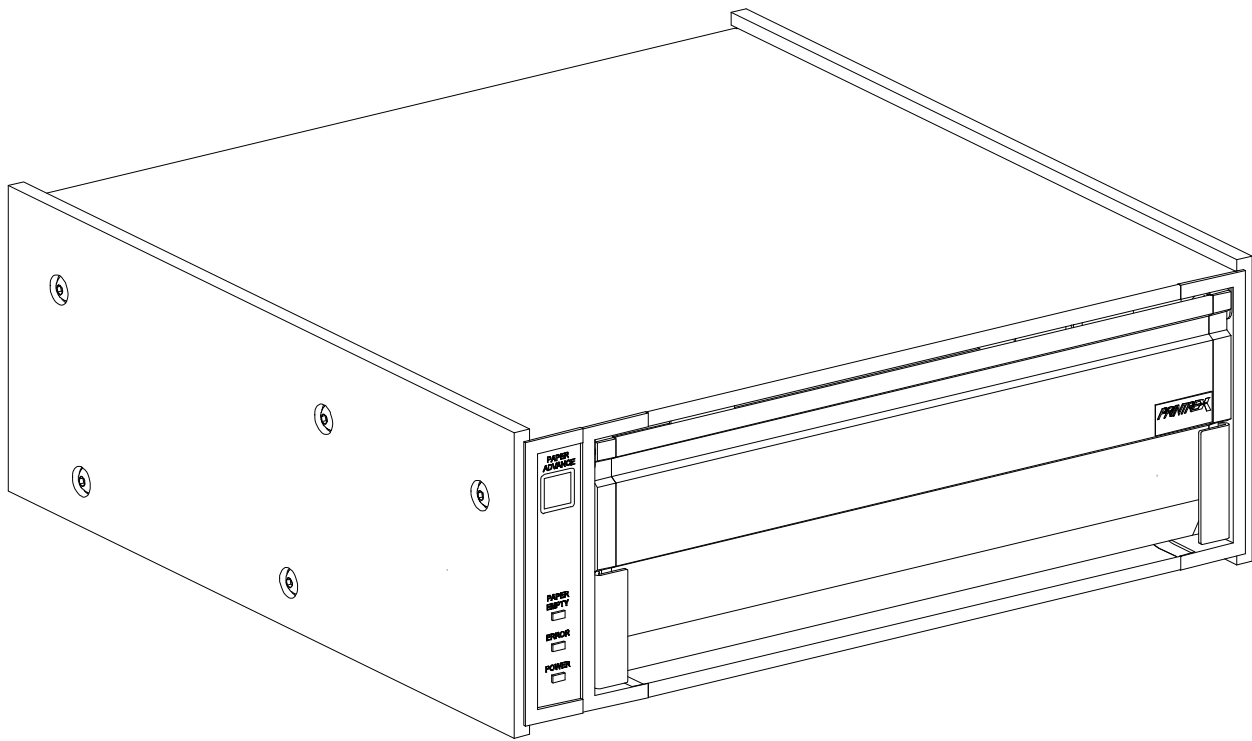

Model 840DL/G • 820DL/G • 820G • 810

Desk Top (DT) Chassis

Table of Contents

1	Introduction	Overview	1-1
		Package Contents	1-2
		Getting Familiar	1-3
2	System Setup	OEM Configurations	2-1
		Connecting the Parallel Interface Cable	2-1
		Connecting the Power Cord	2-1
		Operating System Setup	2-2
		Network Setup	2-3
3	Operation	Loading paper	3-1
		Tearing Paper	3-3
		Forms Marks	3-3
		Running Self Test	3-3
		Advancing Paper	3-4
		Printing	3-4
		Clearing a Paper Jam	3-4
		Additional Controls (via Windows™)	3-4
		Errors and Error handling	3-5
		Troubleshooting	3-5
4	Care / Cleaning	General Cleaning	4-1
		Protecting the Thermal Head	4-1
		Cleaning the Thermal Head	4-1
		Cleaning the Form Sensor	4-1
		Long Term Storage	4-1
5	Service / Support	Warranty	5-1
		Service Policy	5-1
		Obtaining Service	5-1
		Self Service	5-1
		Service Centers	5-2
		Spare Parts	5-2
		Supplies	5-2
		Accessories	5-2
		Additional Documentation	5-2
		Windows™ Drivers	5-2
		Contact Information	5-2
6	Safety	Restriction On Use	6-1
		Grounding	6-1
		Power Cord	6-1
		Serviceability	6-1
		Regulatory Compliance	6-1
7	Technical Specifications	General Specifications	7-1
		Performance	7-1
		Forms Compatibility	7-1
		Environmental	7-1
		Regulatory	7-1

Overview

This User Guide describes the general operation and care of the DT (Desk Top) Chassis series of industrial printers/plotters. The specific DT Chassis models covered by this guide are the **840 DL/G**, **820 DL/G**, **820G** and **810**.

These products are designed for use in a variety of environments, including rugged mobile data logging and exploration systems. While highly durable and reliable in service, best performance and product life will be assured if some degree of care is taken when installing the printers and when providing routine maintenance.

Reading the following sections describing the setup, operation and basic care of the printer will very likely answer questions you might have regarding these aspects of using Printrex products. Should you have further questions, more information is available as described in the *Additional Documentation* section of this guide. If the documentation fails to address your concerns, please contact Printrex support (see *Contact Information*) and we will make every effort to provide a solution.

Refer to the following table for the discriminating DT Chassis features.

Model	840DL/G	820DL/G	820G	810
Print Speed (ips)	4	2	2	1
Integrated Internal Roll	✓	✓	✓	✓
Bottom Feed Fan-fold	✓	✓	-	-
Film/Mylar Media Support	✓	✓	✓	✓
Win95/98/ME and Win2000/XP Support	✓	✓	✓	✓
Vertical Line Adjustment	✓	✓	✓	✓
Extended Media Controls	✓	✓	✓	-
32 Level Gray Scale Printing	✓	✓	✓	-
Autorange 115/220VAC Power	✓	✓	✓	✓
Fan Cooled	✓	-	-	-
CE Certification (ITE, Safety and EMC)	✓	✓	✓	✓
FCC Class A	✓	✓	✓	✓

Firmware (Software) Information

The Firmware (Software) resident in the Printer is owned by Printrex or its suppliers and is licensed for use only on a single printer in the user's Trade or Business. **The User agrees not to, and not to authorize or permit any other person or party to duplicate or copy the Firmware or the information contained in the nonvolatile or programmable memory.** The firmware (Software) is protected by applicable copyright laws and Printrex retains all rights not expressly granted. In no event will Printrex or its suppliers be liable for any damages or loss, including direct, incidental, economic, special, or consequential damages arising out of the use or inability to use the Firmware (Software).

Copyright Information

Windows and Windows NT are trademarks and Microsoft is a registered trademark of Microsoft Corporation.

Ethernet is a registered trademark of Xerox Corporation.

All other brand and product names are trademarks, service marks, registered trademarks or registered service marks of their respective companies.

Package Contents

You should find the following items when unpacking your printer. If any of these items are not found with the printer, please contact Printrex Customer Service.

- DT Chassis Printer

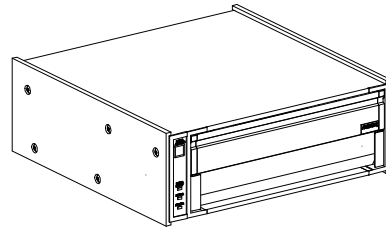

- 8 3/4 Inch Paper Carrier

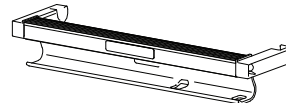

- Paper Rod



- Power Cord (one of the three US, UK or Central Europe plug type, according to the order number suffix)

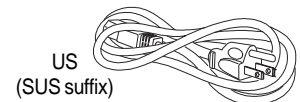

US
(SUS suffix)

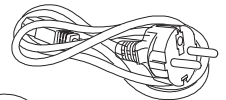

Central Europe
(SCE suffix)



United Kingdom
(SUK suffix)

- Thermal Paper Roll

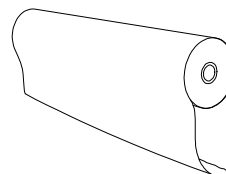

- This Manual



There is also a styrene spacer that keeps the print head pressure off the platen during shipment and storage. This spacer is not required for operation and can be discarded.

Getting Familiar

Refer to the Feature Description Table Figures 1 through 4 to familiarize yourself with the features of the printer. The names of these features will be used throughout this guide.

Feature Description Table

FEATURE	DESCRIPTION	FIGURE
Bottom Feed Slot	Paper entrance slot for bottom paper feed applications	3
Chassis Label	Indicates Part Number, Revision, Full Model and Serial Number	2
Door Latches	For opening and latching closed	1
Error Indicator	Indicates error conditions (see <i>Errors and Error Handling</i>)	4
Form Sensor Window	Form detector window to view form mark	5
Front Panel	Operator controls and indicators	1
Model Label	Indicates the installed print engine model	1
Paper Advance Button	Advance paper and used to enter self-test	4
Paper Empty Indicator	Indicates a paper empty condition	4
Paper Empty Switch	Paper empty detection switch	5
Paper Rod	Center spindle for internal roll paper supply	1
Paper Carrier	Internal roll paper holder	1
Paper Tear Edge	Paper tearing bar	1
Parallel Interface Connector	High speed parallel interface connector to host computer	2
Platen	Printer platen roller	5
Power Entry Module	IEC power entry module for power entry	2
Power Indicator	Indicates power is applied to the printer	4
Power Switch	Controls power to the printer	2

Figure 1

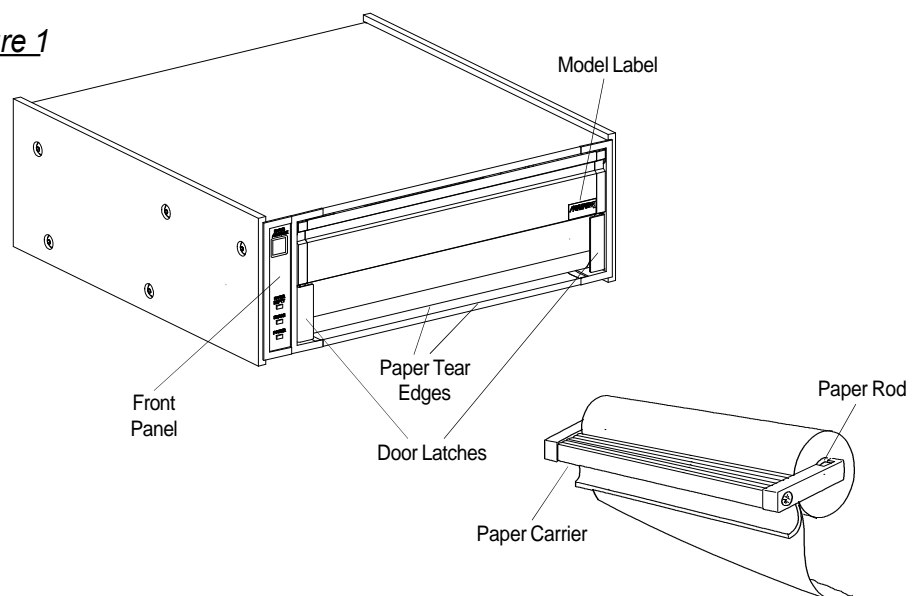

Getting Familiar (Continued)

Figure 2

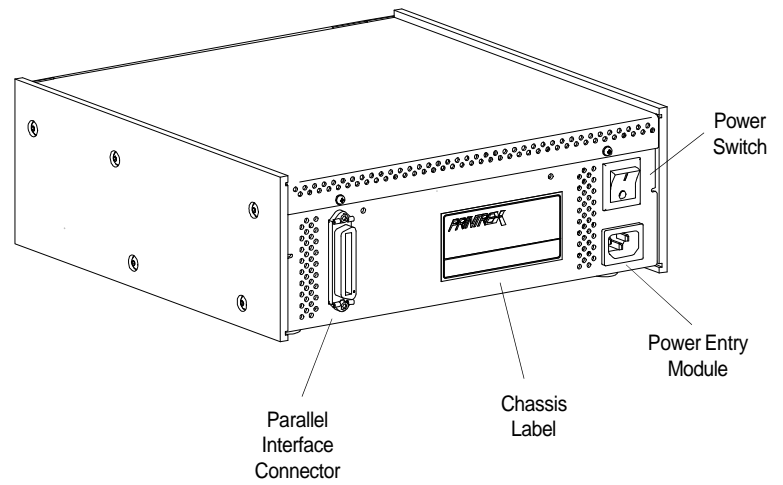

Figure 3

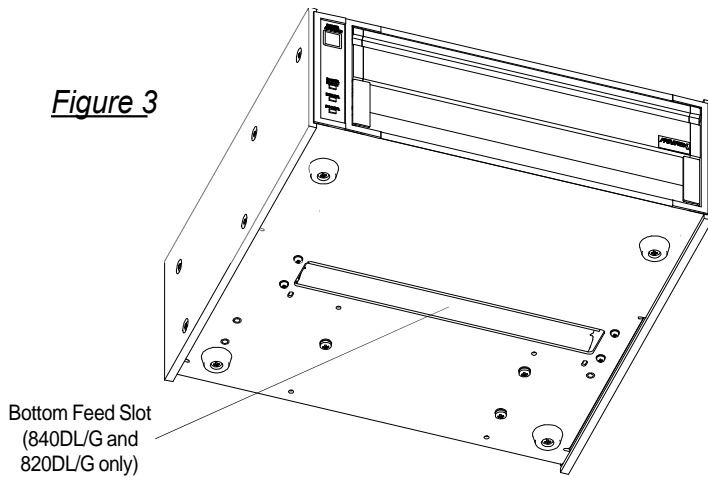

Figure 4

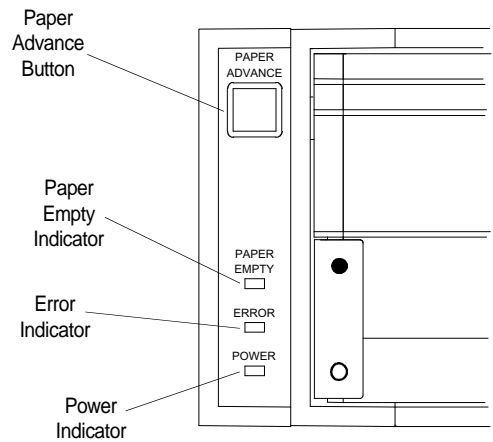
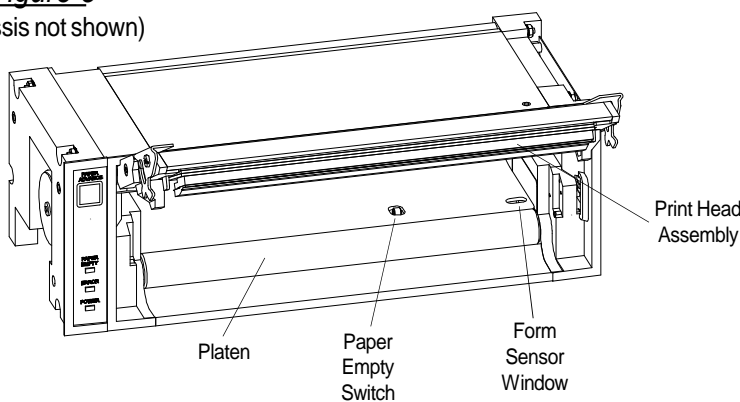

Figure 5
(Chassis not shown)



OEM Configurations

Many different OEM organizations have been integrating Printrex products into combined hardware and software systems; some for nearly 20 years. These complete-solution products may be assembled in closed physical packaging or racks, or may consist of pre-configured computer hardware that is deployed like any other office equipment. Software may be command-line or graphically operated, and might be installed with a Unix-type or Microsoft operating system. Interconnection interfaces include various types of parallel or serial ports, USB and/or Ethernet.

While Printrex has experience in supporting the development of a variety of these OEM systems, it is impossible for us to maintain the information and knowledge necessary to provide detailed support in the operation of these systems. Persons having questions regarding use of a specific product are best advised to consult the documentation or support services provided by the OEM.

For clients directly receiving Printrex products to install as end users into existing or new systems, we wish to make the installation process as trouble-free as possible. Several documents are available for reference which are intended to describe the most common installation scenarios (see the *Additional Documentation* section of this guide).

Connecting the Parallel Interface

First, be sure to use a high-quality cable. The cable should be marked "IEEE-1284" to indicate compliance with this communications standard. Inexpensive cables are electrically inferior and can result in unnecessary communications errors.

Connect the 25-pin connector end of the cable to the parallel port of the computer. Use the screw locks to secure the cable, but do not tighten excessively.

Make sure the printer power is off, then, plug the Centronics 36-pin connector end of the cable into the printer and engage the spring clips to lock the connector.

Avoid making any other connections between computer and printer, whether to add extension cables or to install daisy-chain disk drives or scanners. Integrity of communications is greatly degraded when these items are in the signal path.

For other installation and connection options, please refer to the Printrex System Administrator's Guide.

Connecting the Power Cord

First turn Power Switch to the off position (the off position is shown by the international symbol "O"). Connect the IEC female end of the cord to the power connector on the rear of the printer chassis. Plug the male connector into a properly grounded three-pin AC main power outlet.

Do not use a "cheater" connector in order to use an inexpensive two-wire outlet or extension cord. This defeats the grounding protection of the product and may introduce a serious electrocution hazard in wet environments.

Operating System Setup

The majority of Printrex customers use our printers with computing equipment that functions with the support of an operating system. Microsoft Windows XP and Windows 2000 are the most prevalent systems in current use. In order to provide the best quality of printed output and most convenient user interface, Printrex continually reviews and updates drivers for these platforms.

The 'consumer' operating systems (Windows 95, 98, and ME) are in the twilight of support by Microsoft and are therefore supported at a lower priority by Printrex as well. Specific issues regarding current drivers for these platforms may be referred to Printrex technical support for correction; custom feature additions will be addressed on a per request basis.

The paragraphs below apply to users installing printers by connecting directly to the computer in use. For connecting to a network, see the following section on Network Setup.

Windows™ 2000/XP

Because drivers for these platforms are subject to periodic updates, visit the Printrex website (www.printrex.com/drivers.htm) and download the most recent drivers. Expand the compressed file onto a floppy disk and open the Printers folder (*Start – Settings – Printers*). Start the **Add Printer** wizard and follow the instructions, selecting **Have Disk** when prompted for 'Manufacturers' and 'Printers'.

After completing the wizard, right-click on the new printer icon in the Printers folder, and select 'Printing Preferences'. Click the **Advanced...** button to display the *Advanced Options* dialog. This determines the "default" settings of the printer. Most users will wish to change the *Paper Size* from 'Letter' to the actual form loaded in the printer, as well as the *Media Selection* and *Form Marker Type*. Other settings may need adjustment as well, depending on application.

For further information on installation, see publication 1028-0061, [Printrex Driver Installation Guide](#).

After installation, publication 1028-0062, [Printrex Windows Driver User Guide](#) may be used as a reference in applying the driver settings needed for a particular printing task. Many different types of applications can be accommodated by the drivers, using a variety of media. While the default control values are a good starting point for most print jobs, many users will wish to fine-tune driver settings to obtain the best quality possible.

Windows™ 95/98/ME

First, check the Printrex website for updated driver versions (www.printrex.com/drivers.htm).

After extracting the compressed driver files to a floppy disk, go to the *Start – Settings – Printers* folder, and double-click **Add Printer**. Proceed with installation, and click the **Have Disk** button when the 'Manufacturer' - 'Model' dialog is displayed. When the wizard finishes, right-click on the printer icon and select 'Properties'. Make adjustments as needed, for paper size, media type, and other features. For further information on installation, see publication 1028-0063, [Printrex System Administrator's Guide](#).

UNIX and Other Operating Systems

At this time, Printrex does not distribute filter files for UNIX (and UNIX-type) platforms. Users of applications designed for use on these systems are advised to contact the application vendor for assistance with setup.

Network Setup

Many permutations of network connections and configurations exist. It is well worth taking some time to design the installation with consideration to future expansion and updates.

When connecting the printer within a mixed environment, there are additional choices available and decisions to be made. Hardware print server boxes provide multi-protocol support for numerous platform configurations and communications standards.

Refer to publication 1028-0063, [Printrex System Administrators Guide](#) for further information.

Loading Paper

Loading An Internal Roll

Unlock the door of the printer by pressing on the open circles printed on the two latches at the lower corners of the door. Pull up on the latches to open the door.

① Unlock Door

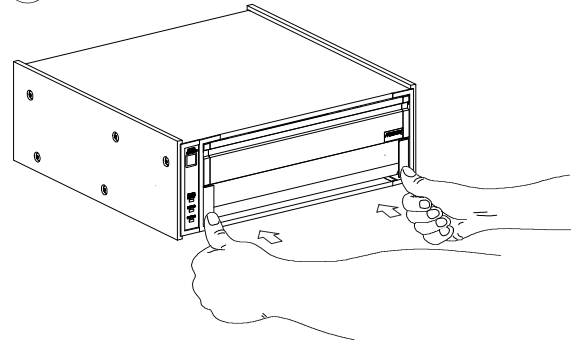

② Remove Paper Holder

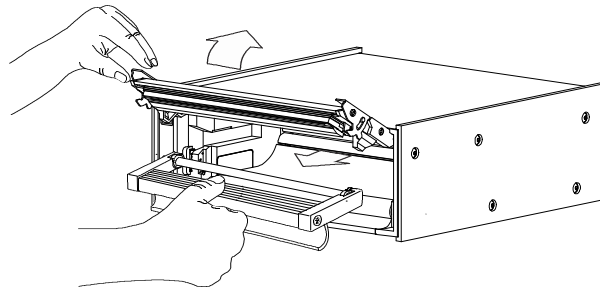

Remove the paper carrier from the printer and remove the paper rod from the carrier. Slip the empty core off the paper rod.

Slip the paper rod through the core of the new paper roll and install the paper roll on the carrier so the paper feeds from the top of the roll toward the front of the carrier. Feed a few inches of paper from the roll so it will extend over the platen after insertion.

③ Insert Roll In Printer

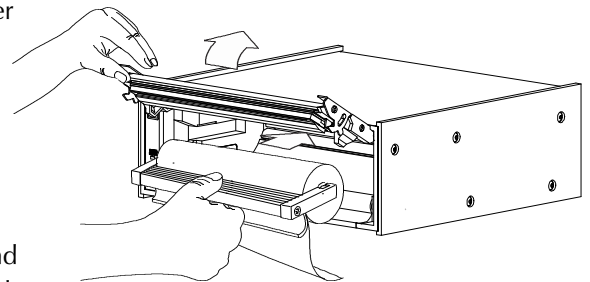

Insert the paper carrier in the printer and close the door with the latches unlocked.

④ Lock Door

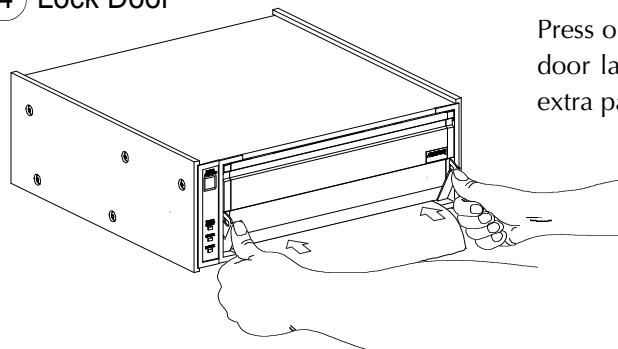

Press on the solid circles printed on the door latches to lock them. Tear off the extra paper.

Loading Paper Continued

*Loading External Media
(Models 840DL/G and
820DL/G only)*

Loading external media is similar to loading an internal roll. The difference being the paper is threaded through the bottom feed slot. Note: The printer is shown with an optional Paper Tray. See Accessories Section 5-2 for ordering information.

1 Place Printer On Stand

Place the printer on the paper tray.
The printer position is set by the feet
and side plates of the paper tray.

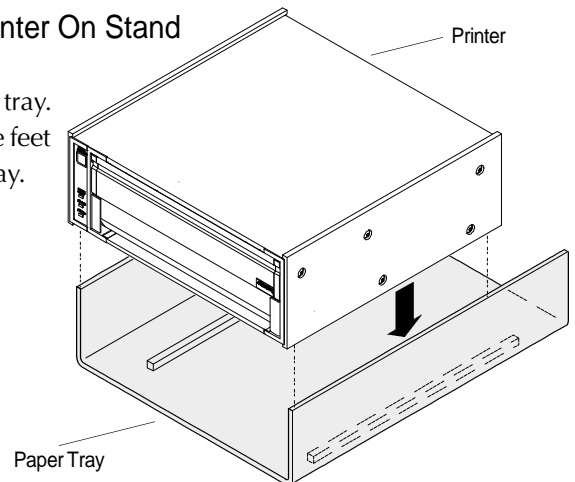

2 Rotate Printer to Upright Position

Rotate the printer to the
upright position, open
the door and remove
the paper carrier.

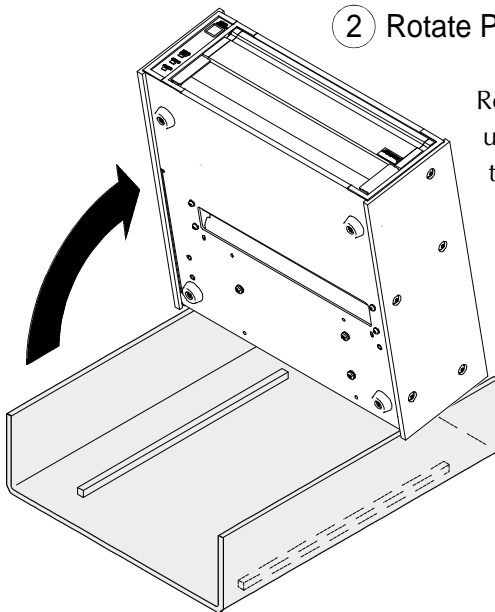

3 Thread Paper

Insert paper through the Bottom Feed
Slot and out through the door as
shown. Observe the orientation of the
Forms Mark for correct top-of-form
operation.

Position 11 inch forms even with the
ends of the paper guides for
correct position. Center API
forms between the ends of
the paper guides for
correct position.

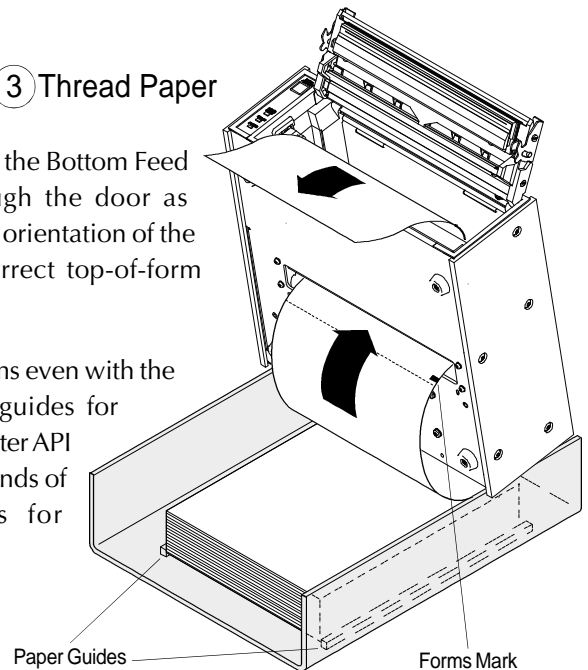

4 Return Printer to Operating Position

Return the printer to the
horizontal position, **insert
paper carrier** and close
the door.

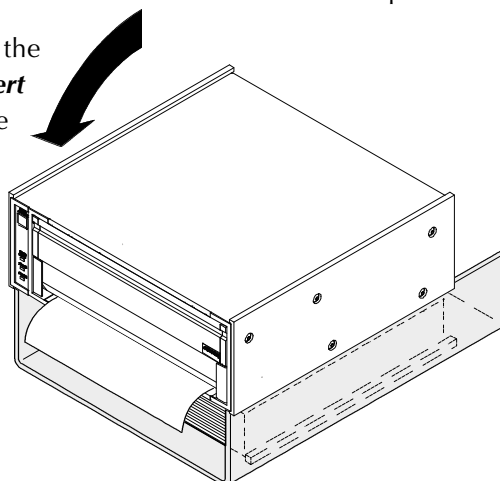

Note: The paper carrier must be
installed to position the paper over
the paper empty sensor and the
form mark sensor.

Tearing Paper

There are two tear bars; one on the bottom of the front door for tearing up and one on the printer housing for tearing down. Pull up or down at approximately a 45° angle and slightly to the right or left to tear the paper.

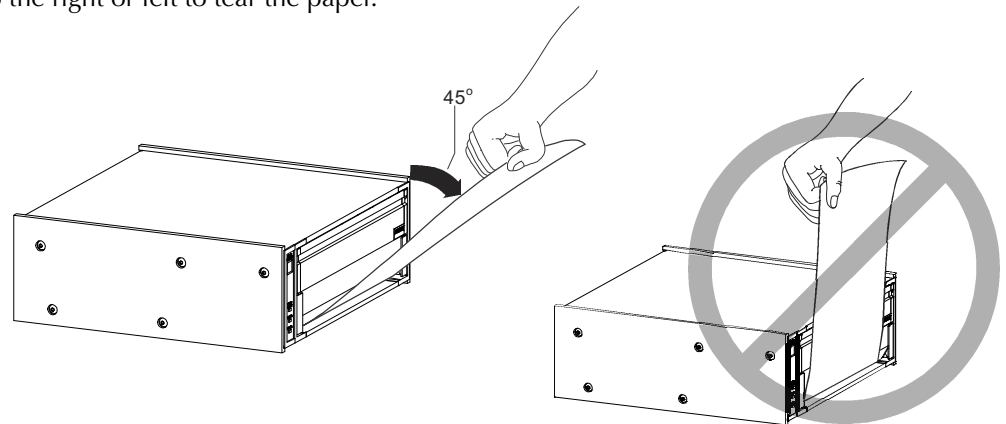

Forms Marks

The forms mark sensor is located in the front right side of the printer. Be sure the paper is loaded as shown below for correct top of form (TOF) detection. Also, be sure the paper size is correctly selected in the Windows™ driver.

A listing of media providers that supply paper with the specified form marker location can be found on the Printrex web site (www.printrex.com). Most other media suppliers can supply compatibly marked forms provided they receive the marker specifications shown to the right.

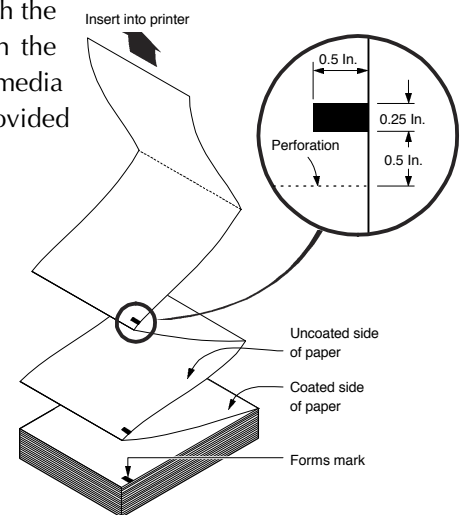
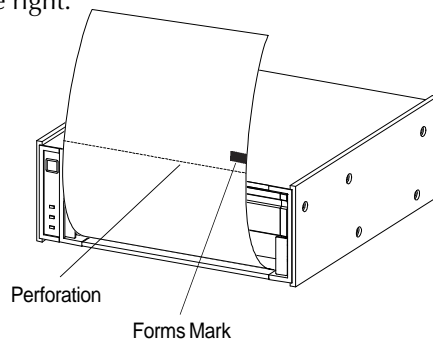

Running Self Test

To perform self test, press and hold the PAPER ADVANCE button while turning on power. The PAPER ADVANCE button may be released after self test has started. In self test, the ERROR indicator lights and a printout of model, interface type, firmware version and other various test patterns is started. The test printout will stop after the last test pattern is printed and the printer will exit self test and return to normal operating mode.

There are times when it is useful to have the test pattern repeated. If the PAPER ADVANCE button is held while the first self test pattern is finishing, the printer will enter a repeating self test mode where the entire self test pattern is repeated until the unit is powered off.

Advancing Paper

After loading paper, or any time you wish to advance paper, press the Paper Advance button on the front panel. The printer will feed paper as long as the button is pressed, but will stop when either of two conditions is met:

- If the paper has form markers printed on the back surface, the printer will stop when a marker is detected.
- The logical page length has passed *without* a form marker being seen. The power-up default page length is 16.7 inches. This length may be changed by sending the printer control codes in software.

Releasing the button and pressing again repeats the cycle of feeding and stopping.

Printing

When print jobs are sent to the printer continuously, there is no mechanical duty cycle limitation; some users report 10 hours a day of nonstop printing as normal usage. However, if the print data contains an unusually high proportion of black areas, the printer may go into an over-temperature condition. This may also occur when printing less dense print jobs if the ambient temperature is very high. Refer to the following section on Errors and Error Handling for information on the front-panel indication of temperature errors. Recovery from temperature errors is automatic, and needs no user action to resume printing.

Clearing a Paper Jam

If paper has been loaded askew, or has been torn off forcefully, or is damp, the paper may feed abnormally and wrap around the platen roller. These occurrences are extremely rare, but it is important to know the following method of clearing the jam:

- Turn off power to the printer.
- Open the printer door, and remove the paper holder and roller.
- Tear off the incoming paper (either from the roll, or fanfold supply).
- Pull on the free end of paper with one hand, while turning the platen roller with the other hand, to unroll paper from the platen.
- Do not use a razor, knife or sharp object of any kind to cut the paper off of the platen roller. Nicking or cutting the roller surface will result in worsening damage to the platen with continued use of the printer.
- Be very careful not to damage the print head that is exposed on the underside of the door. This should not be an issue if only bare hands are used to free the paper.

Additional Controls

The Front Panel controls are intentionally minimal. This ensures that one user's print jobs in a network environment are not ruined by other users manually making unannounced changes to printer settings. The Printrex Windows drivers send control codes to the printer for *each* print job, so it is important to check driver settings before printing. Note that some geotechnical applications bypass the Windows drivers, and provide a limited subset of printer controls. Check with your application's documentation to determine if this is the case. If so, settings made in the Windows driver will not affect printing from these applications.

Errors and Error Handling

The Error Indicator on the Front Panel indicates an error condition of the printer. This indication is in the form of a two digit error code expressed as a series of long flashes (for the tens digit) then short flashes (for the ones digit). The tens digit flash is twice as long as the ones digit flash. Example: One long flash followed by two short flashes indicates an error code of 12 (Door Open).

The Error Indicator will continue to flash the error code while the error condition exists. Refer to the following table for a list of error codes and their meaning.

ERROR CODE	NAME	DESCRIPTION
11	Paper Empty	A paper empty condition exists. Cleared by loading paper.
12	Door Open	One or both of the Door Latches are unlatched. Cleared by latching both door latches.
21 ⁽¹⁾	Under Voltage	The internal DC supply voltage is too low to print properly. Service is generally required to clear this condition.
22	Over Voltage	The internal DC supply voltage is too high to print properly. Service is generally required to clear this condition.
23 ⁽¹⁾	Under Temperature	The thermal head is too cold to print properly. Cleared when the ambient temperature sufficiently increases.
24	Over Temperature	The thermal head is overheated. Cleared when the thermal head cools off.

NOTE 1: Model 810 does not indicate an *Under Voltage* or an *Under Temperature* condition. The model 810 printer will print as best as possible given the voltage or temperature is lower than nominally expected.

Troubleshooting

This section lists a few common questions that are received by Printrex support staff and the answers most likely to fix the problem. For further information, see the Printrex System Administrator's Guide.

1. *The printer seems to be working but nothing is printed.*

The thermal paper has one side that has a thermal sensitive coating while the other side is not coated. Be sure the thermally coated side is facing upward (as the paper is exiting the printer).

2. *My printer is too slow! What's wrong?*

(Windows XP/2000/NT4)

These operating systems do not support high speed data transfer using the default (Microsoft) parallel port driver. Printrex recommends using a USB to Parallel converter cable when connecting the printer directly to PCs using these operating systems.

(Windows 95/98/ME)

Check the parallel port settings in the BIOS and be sure it's set to ECP mode.

3. *I'm using fanfold paper with form markers, but the printer stops in the wrong place. What driver settings should I use?*

Be sure to set the Paper Size to the actual size of the paper (8.75 x 6.25), and enable End-of-Job Form Feed. Also, see that the Form Marker setting (in Windows XP/2000 driver) matches the actual printed location of the marker. Check that the paper is loaded correctly: looking at the front of the printer, the marker should be on the right side, on the bottom of the paper.

Troubleshooting
(Continued)**4. I'm trying to print TIFF files, but the printed output is clipped off. How do I print the whole log?**

This question has come from the geotechnical community frequently over the last several years. Commonly, users view TIFF logs in Windows Imaging, the free viewer provided in the Programs- Accessories folder. Unfortunately, this is a *single-page* application: it is designed for simple photograph- size viewing *and printing*. Further, the Windows printing subsystem (prior to Windows 2000) limited printer pages to 32,766 raster lines (approximately 163 inches long for the Printrex printers), so the longest log that could be printed from Imaging was just 13 feet long. In Windows XP, the Imaging applet was replaced by a new Paint applet that *does* print using multiple printer pages. In this case, set the printer page size to the paper's page size (8.75 x 6.25 half page), and Paint will generate as many printer pages as needed to print the log.

In most of the larger geotechnical organizations, proprietary viewers have been written for internal use by authorized staff and customers. Remarkably, there are very few options for other users of TIFF log files who are not using Windows XP, or who find the XP Paint application too primitive.

Printrex welcomes comments regarding requirements and features for log viewing tools, for possible development of a viewer application for our customers.

5. Every time I start my program, I have to change printer settings. How do I change the default driver settings?

In Windows 95/98/ME, go to the Start – Settings – Printers folder. Right-click on the printer icon, and select 'Properties'. In Windows NT4, right-click on the printer, and select 'Document Defaults'... *not* 'Properties'. In Windows XP/2000, right-click on the printer, and select 'Printing Preferences'. (If you select 'Properties', go to the 'General' tab, and click the 'Printing Preferences' button.

In Windows NT4/2000/XP, changes to the printer settings done from within an application are generally not saved unless some unusual program coding is done.

6. Self test prints out OK but when I print from the computer I get garbage.

Common problems for this symptom are the parallel cable or the printer driver that is being used. Be sure the parallel cable is appropriately connected (see section Connecting the Parallel Cable). Also, be sure the printer driver is for the specific model printer that is being used.

7. Some times the fan-fold paper skews to one side or the other. How do I correct this?

The Printrex printers are designed to work with a wide variety of media. A paper skewing problem is normally corrected by realigning the paper. This is done by opening the door, straightening the paper and closing the door. We have found however, that under some conditions (generally with very thin paper) the problem may persist. If this is the case, we suggest threading the paper over a full internal roll of paper (as shown) to remedy the situation.

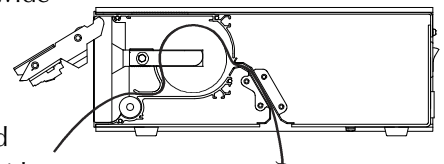

General Cleaning

There is no regular cleaning required for proper operation of the printer, however the printer surfaces are designed and manufactured to permit cleaning with the following cleaning agents:

- Isopropyl alcohol
- Ammonia
- Chlorine bleach (1:10 concentration with water)
- Hexachlorophene (PhisoHex)
- Glutaraldehyde (Cidex)

It is recommended that a soft cloth dampened with the cleaning agent be used to clean the surfaces of the printer. Do NOT submerge or allow spills onto or in the product.

Protecting the Thermal Head

The thermal head incorporates a protective glaze coating and is generally resistant to harsh environments, however the following precautions should be taken regarding the thermal head surface:

- Do not allow the thermal head to come in contact with sharp or hard objects.
- Do not allow thermal paper debris to accumulate on the thermal head.
- Do not allow condensation to accumulate on the thermal head.
- Use only Printrex approved thermal paper
- Do not expose the thermal head to abrasive cleansers.

Cleaning The Thermal Head

Paper dust or other foreign material may occasionally accumulate on the thermal print head. This will be indicated by light print or no print in a narrow band down the length of the paper. In order to eliminate the thermal paper debris buildup, it is recommended to use a soft cloth moistened with one of the following cleaning agents:

- Isopropyl alcohol
- Ethanol

A light wiping along the length of the print head is adequate. Allow the print head to dry before resuming printing. It can be wiped dry with a soft, clean cloth. Do NOT submerge or allow spills onto the thermal head.

Cleaning The Form Sensor

Paper dust or other foreign material may occasionally accumulate on the form sensor. This will be indicated by missing the top of form position (some time after it has been correctly stopping at the top of form). The form sensor can be cleaned with an aerosol air spray or soft bristled brush. It is located just under the form sensor window.

Long Term Storage

With the paper door closed, the thermal head applies a considerable pressure on the platen (approximately 8 kg). If the printer is stored for long periods of time with the paper door closed (especially in cold temperatures), it is possible that a slight flat area is induced in the platen. It is recommended the paper door be kept in an unlatched condition for extended periods of storage. Note: The condition of a flat spot on the platen is not permanent and the platen will return to its normal roundness after 10 or so minutes of resumed operation.

Warranty

Printrex products are warranted to be free from failures due to defects in material and workmanship for twelve (12) months from the date of purchase. During this 12 month period Printrex will, at its sole discretion, replace or repair at no charge the product which, in its opinion, is defective.

If the failed product has been modified without Printrex's consent or if the failure is the result of misuse, abuse or misapplication, Printrex has no obligation to repair or replace the failed product.

Consumables Warranty: Printrex warrants that the thermal print head will be free from defects for the Expected Life of the printhead but not more than one (1) year from the date of purchase. The Expected Life of the printhead is considered to be the lesser of, A) fifty (50) kilometers of delivered media or B) one hundred million (10⁸) pulses of an individual print element (approximately 12.7 km of converted printout for any given print element).

Except as expressly provided above, the hardware and accompanying written materials (including the User's Guide) are provided 'as is' without warranty of any kind, including the implied warranties of merchantability and fitness for a particular purpose, even if Printrex has been advised of that purpose. In no event will Printrex be liable for any direct, indirect, consequential, or incidental damages arising out of the use of or inability to use such product even if Printrex has been advised of the possibility of such damages. Some states do not allow the exclusion or limitation of liability for consequential or incidental damages, so the above limitation may not apply.

Service Policy

Following the warranty period Printrex will repair defective products and will charge a fee to cover handling and service costs based on Printrex's then-current price schedule.

Obtaining Service

Before returning a failed unit, the buyer must first obtain a Return Material Authorization (RMA) number by contacting Printrex's Customer Service. The RMA number should be prominently displayed on the outside of the returned package and on the accompanying packing list. Printrex cannot be held responsible for any package returned without an RMA number. The model and serial number of the printer is on the chassis label located on the rear of the printer. Please have this information available when service is required.

The user is responsible for packing the failed product in original or equivalent packaging for shipment, and for the charges to ship the failed product to Printrex. Printrex is responsible for charges to ship the repaired or replaced product if under warranty. If any charge to you is involved, Printrex, at its sole option, will bill you or return the product C.O.D.

Self Service

Printrex recognizes that some customers have service departments that are capable of servicing the Printrex products. For this case, Printrex offers a Self Service Reference. This reference includes assembly drawings with bills of material so that replaceable internal components can be identified and ordered. Please contact Printrex Customer Service to obtain a Self Service Reference for your product(s). For self service, the owner assumes the risk of damage to the unit and may violate the warranty.

Service Centers

A list of service centers are available from the Printrex web site. Please refer to: www.printrex.com

Spare Parts

Description	Part Number
Paper Carrier	2111-0189
Paper Rod	2012-0008
Power Cord (Central Europe plug)	2237-0004
Power Cord (United Kingdom plug)	2237-0061
Power Cord (United States plug)	2237-0007
Print Head Assembly	2111-0175

Supplies

Description	Part Number
Roll Paper, 150' length	2316-0001
Roll-FF Paper, 150' roll (6 1/4" Perf. Intervals)	2316-0013
Fan-Fold Paper, 8.75 x 6.25 inch, 800 sheet box	2316-0011
Roll Matte Film, 117' length	2316-0009

Accessories

Description	Part Number
USB Adapter Kit	2012-0030
Paper Tray (Bottom feed tray, for 840DL/G and 820DL/G)	2320-0014

Additional Documentation

Description	Part Number
Driver Installation Guide, Win2000/XP	1028-0061
Driver User Guide, Win2000/XP	1028-0062
Self Service Guide, 840DL/G DT Chassis	1028-0073
Self Service Guide, 820DL/G DT Chassis	1028-0075
Self Service Guide, 820G DT Chassis	1028-0077
Self Service Guide, 810 DT Chassis	1028-0079
System Administrators' Guide	1028-0063

Windows™ Drivers

Windows drivers are available from the Printrex Web Site. Please refer to: www.printrex.com/drivers.htm

Contact Information

Printrex, Inc.
276 East Gish Road
San Jose, CA 95112-4703 USA
Telephone: +408.573.1200
Fax: +408.573.1600
E-mail: info@printrex.com

Restriction on Use

Use this equipment only for its intended use as described in this guide.

- Do not use power supplied outside the specified voltage/hertz range.
- Do not block any openings on the equipment.
- Do not use corrosive chemicals or vapors on the equipment.
- Do not expose equipment to rain or spills or moisture.

Grounding

This equipment must be grounded to conform with the normative safety standards. Connect only to a properly grounded outlet.

Power Cord

The power cord supplied with the equipment is rated and approved for service to this equipment.

- Do not operate the equipment if it has a damaged power cord or plug.
- Do not immerse the power cord or plug in water.
- Do not use a power cord other than that supplied with the equipment.

Serviceability

There are no user-serviceable parts inside the equipment. Refer all service to a qualified service technician.

Regulatory Compliance

FCC Compliance

This unit has been tested and found to comply with the limits for a Class A digital device, pursuant to Part 15 of the FCC Rules. These limits are designed to provide reasonable protection against harmful interference when the equipment is operated in a commercial environment. This equipment generates, uses, and can radiate radio frequency energy and, if not installed and used in accordance with the instruction manual, may cause harmful interference to radio communications. Operation of this equipment in a residential area is likely to cause harmful interference in which case the user will be required to correct the interference at his own expense.

CE Compliance

The manufacturer declares that this product conforms to the following standards or other normative documents:

- EMC: EN 55022:1994 Limits and Methods of Measurements of Radio Interference Characteristics of Information Technology Equipment, Class A, including amendments A1:1995, A2:1997
EN 50024:1998 Limits and method of measurement of Immunity characteristics of Information technology equipment
- Safety: EN 60950:1992 Safety of information technology equipment including electrical business equipment, including amendments A1:1993, A2:1993, A3:1995, A4:1997, A11:1997

General Specifications

Power Requirements (840DL/G)	100-240 VAC, 500 VA, 50~60Hz
Power Requirements (820DL/G and 820G)	100-240 VAC, 240 VA, 50~60Hz
Power Requirements (810)	100-240 VAC, 150 VA, 50~60Hz
Height	4.5 inch (114 mm)
Width	12.2 inch (310 mm)
Depth	12.4 inch (315 mm)
Unit Weight	14 lbs (6.4 kg)
Shipping Weight	18 lbs (8.2 kg)
Interface	High Speed Parallel

Performance

Print Speed (840DL/G)	0.5 to 4 inch/sec
Print Speed (820DL/G and 820G)	0.5 to 2 inch/sec
Print Speed (810)	0.5 to 1 inch/sec
Horizontal Resolution	203 dpi (8 dots/mm)
Vertical Resolution	203 dpi (8 dots/mm)

Forms Compatibility

Overall Forms Width	8.75 inch (222 mm)
Internal Roll Capacity	2.6 inch (66 mm) diameter roll
For 840DL/G and 820DL/G:	
Bottom Feed Roll Capacity	5 inch (152 mm) diameter roll
Bottom Feed Fan-fold Capacity	18 inch (457 mm) stack height
Forms Mark	See Section 3-3 for forms mark specifications

Environmental

Storage Temperature	-40°C (-40°F) to 60°C (140°F)
Operating Temperature (non-condensing)	5°C (41°F) to 40°C (104°F)
Shock & Vibration (non-operational)	3G, 0 to 50 Hz, 3 axes
Environmental Ingress (IEC 529)	IP54

Regulatory

CE	ITE Directive, Edition 2
FCC	Class A

Information in this document is subject to change without notice and does not represent a commitment on the part of Printrex, Inc. No part of this manual may be reproduced or transmitted in any form or by any means, for any purpose other than the purchaser's personal use, without the expressed written permission of Printrex, Inc.

All rights reserved. Printed in the United States of America.

© Copyright 2003 by Printrex, Inc.

Part Number: 1028-0071 Rev 1

Free Manuals Download Website

<http://myh66.com>

<http://usermanuals.us>

<http://www.somanuals.com>

<http://www.4manuals.cc>

<http://www.manual-lib.com>

<http://www.404manual.com>

<http://www.luxmanual.com>

<http://aubethermostatmanual.com>

Golf course search by state

<http://golfingnear.com>

Email search by domain

<http://emailbydomain.com>

Auto manuals search

<http://auto.somanuals.com>

TV manuals search

<http://tv.somanuals.com>