

PRINTRONIX®

Setup Guide



L1024 Continuous Form Laser Printer

*L1024 Continuous Form Laser Printer
Setup Guide*

PRINTRONIX®

705815-001, Rev A

US and CANADA Radio Interference Note

Note: This device complies with Part 15 of the FCC Rules. Operation is subject to the following two conditions: (1) this device may not cause harmful interference, and (2) this device must accept any interference received, including interference that may cause undesired operation.

Properly shielded and grounded cables and connectors must be used in order to meet FCC emission limits. The manufacturer is not responsible for any radio or television interference caused by using other than recommended cables and connectors or by unauthorized changes or modifications to this equipment. Unauthorized changes or modifications could void the user's authority to operate the equipment.

The input/output (I/O) cable must be shielded for the printer to comply with FCC rules and regulations Part 15 governing the radiation limits for Class "A" equipment.

This Class A digital apparatus meets all requirements of the Canadian Interference-Causing Equipment Regulations.

Cet appareil numérique de la classe A respecte toutes les exigences du Règlement sur le matériel brouilleur du Canada.

WARNING

This is a Class A product. In a domestic environment this product may cause radio interference in which case the user may be required to take adequate measures.

Printronix, Inc. makes no representations or warranties of any kind regarding this material, including, but not limited to, implied warranties of merchantability and fitness for a particular purpose. Printronix, Inc. shall not be held responsible for errors contained herein or any omissions from this material or for any damages, whether direct, indirect, incidental or consequential, in connection with the furnishing, distribution, performance or use of this material. The information in this manual is subject to change without notice.

This document contains proprietary information protected by copyright. No part of this document may be reproduced, copied, translated or incorporated in any other material in any form or by any means, whether manual, graphic, electronic, mechanical or otherwise, without the prior written consent of Printronix, Inc.

All rights reserved.

Trademark Acknowledgments

Compatibility Software Copyright © 1989 Phoenix Technologies Ltd., All Rights Reserved.

Printronix is a registered trademark of Printronix, Incorporated.

IGP is a registered trademark of Printronix, Inc.

LinePrinter Plus is a trademark of Printronix, Inc.

PostScript is a registered trademark of Adobe Systems.

PhoenixPage PCL 5 is a registered trademark of Phoenix Technologies Ltd.

HP is a registered trademark of Hewlett-Packard Company.

PCL is a trademark of Hewlett-Packard Company.

Code V is a trademark of QMS, Inc.

QMS is a registered trademark of Quality Micro Systems, Inc.

PRINTRONIX®

17500 Cartwright Road, P.O. Box 19559

Irvine, California 92713

Telephone (714) 863-1900 FAX (714) 660-8682

Technical Support (714) 221-2686

COPYRIGHT © 1995, 1996, 1997 PRINTRONIX, INC.

Table of Contents

1 Introduction

About This Manual	1-2
How to Locate Information	1-2
Warnings and Special Information	1-3
Conventions	1-3
The Printer	1-4
Printer Features	1-5
Emulations	1-6
Hardware Options	1-6
Fonts and Forms	1-7
General Laser Printer Technology	1-8

2 Setting Up the Printer

Safety Precautions	2-2
Check the Power Requirements	2-3
Select a Site	2-4
Unpack the Printer	2-6
Initial Setup	2-7
Install the Developer Unit	2-10
Add the Starter Toner	2-11
Install the Ozone Filter	2-13
Install the Waste Toner Container	2-14
Install the Fuser Cleaner Felt	2-16
Install the OPC Drum Unit	2-17
Load Paper	2-18
Install the Emulation Boot Diskette	2-20
Cable Connections	2-21
Check for Interference	2-23
Transporting the Printer	2-24
Short Distance Transport	2-24
Long Distance Transport	2-25

3 Configuring the Printer

Overview	3-4
Changing Printer Settings	3-5
Saving a Configuration	3-7
Modifying a Configuration	3-10
Printing a Configuration	3-13
Factory Settings	3-14
Configuration Menus	3-16
Paper Control Menu	3-17
Image Width	3-18
Paper Length	3-18
Horiz. Image Shift	3-18
Vert. Image Shift	3-18
Reprint on Fault	3-18
Printer Control Menu	3-19
Fuser Temperature	3-20
Energy Timeout	3-20
Diagnostics Menu	3-21
Test Print	3-22
Engine Life Data	3-22
Disk Management Menu	3-23
Load Configuration	3-24
Save Configuration	3-24
Print Configuration	3-24
Delete Configuration	3-25
Power-up Configuration	3-25
Protect Configurations	3-25
Mode (Emulation) Menu	3-26
Impact Printer	3-27
PCL5	3-27
IGP/PGL	3-27
IGP/VGL	3-28

CTHI	3-28
IPDS	3-28
Maintenance/Miscellaneous Menu	3-29
Panel Key Sound	3-29
Alarm	3-29
Power-up State	3-29
Hex Dump Mode	3-30
PTX-Setup Option	3-31
Display Language	3-31
Host Interface Menu	3-32
Centronics Interface Parameters	3-33
Dataproducts Interface Parameters	3-36
Serial Interface Parameters	3-39
Font Memory Menu	3-44
Maximum Character Memory	3-45
Maximum Cache Memory	3-45
Maximum Cache Size	3-46
Maximum Cached Characters	3-46
Maximum Fonts Loaded	3-46
Font Weight	3-47
System Information Menu	3-48
System Memory	3-48

4 Diagnostics and Troubleshooting

Printer Diagnostics	4-2
Off-Line Diagnostics	4-2
On-Line Diagnostics	4-3
Running the Printer Test	4-3
Hex Dumps	4-4
Error Messages	4-5
Operator Calls	4-5
Fatal Error Messages	4-6

Appendices

- Appendix A: Specifications
- Appendix B: Host I/O Interfaces
- Appendix C: Media Requirements
- Appendix D: Disk Space Savings

Glossary

Index

1

Introduction

Chapter Contents

About This Manual	1-2
How to Locate Information	1-2
Warnings and Special Information	1-3
Conventions	1-3
The Printer	1-4
Printer Features	1-5
Emulations	1-6
Hardware Options	1-6
Fonts and Forms	1-7
General Laser Printer Technology	1-8

About This Manual

This manual is divided into chapters that contain all the information required to use the printer.

Chapter 1: Introduction. General information about the manual and the printer, safety precautions, and component locations.

Chapter 2: Setting Up the Printer. Procedures for installing the printer and its components.

Chapter 3: Configuring the Printer. Configuration menus, options, and outlines as well as factory default settings.

Chapter 4: Diagnostics and Troubleshooting. Diagnostics and procedures for clearing paper jams, cleaning the printer, and interpreting the displayed error messages.

Appendix A: Specifications

Appendix B: Host I/O Interfaces

Appendix C: Media Requirements

Appendix D: Disk Space Savings

How to Locate Information

You can locate specific procedures and information three ways:

- Use the **Table of Contents** at the front of the manual.
- Use the **Chapter Contents** list on the first page of each chapter.
- Use the **Index** at the back of the manual.

Warnings and Special Information

For your safety and to protect valuable equipment, it is very important that you read and comply with all information highlighted under special headings:

WARNING

Conditions that could harm you as well as damage the equipment.

CAUTION

Conditions that could damage the printer or related equipment.

IMPORTANT

Information vital to proper operation of the printer.

NOTE: Information and helpful tips about printer operation.

Conventions

Throughout this manual, switches and possible switch settings or positions are printed in UPPERCASE type.

In most cases, messages displayed in the LCD are shown in the following format:

OFFLINE PAPER CONTROL

In some cases, display messages may be shown in UPPERCASE type, surrounded by quotation marks.

The Printer

The printer is a programmable, non-impact printer. The printing technique is a plain paper electrophotographic process, which uses a laser diode. Printer emulations and font software load into the printer via diskettes.

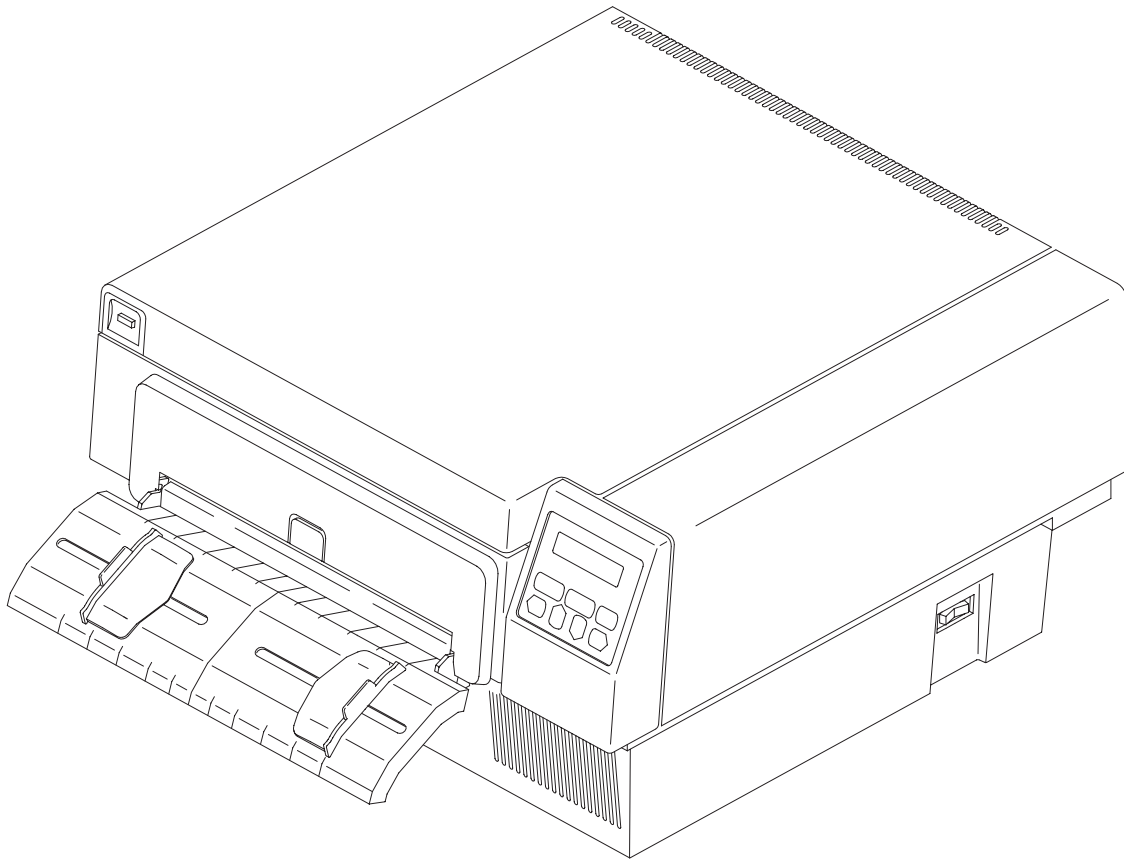

Figure 1-1. The Printer

Printer Features

The printer prints up to 24 pages per minute on an 8.5 x 11 inch page and produces a 300 x 300 dots-per-inch (dpi) resolution on a continuous length printable area. (See Appendix A for printer specifications.)

Features of the printer include:

- Continuous fanfold paper or forms handling
- Supports a wide variety of form lengths
- User-replaceable developer kit, toner kit, and organic photoconductor (OPC) drum kit
- Two-line, 16-character alphanumeric display that provides operating and error messages
- Diskette drive which is used to load and store preset configurations, printer emulations and fonts from a diskette
- Second diskette drive which stores fonts (optional)
- Serial or parallel interface
- Coax or twinax interface (optional)
- Ethernet LAN interface (optional)

Emulations

The printer comes with HP® Laserjet PCL5®, IPDS, or the Printronix LinePrinter Plus™ emulation. The LinePrinter Plus emulation includes the following printer protocols:

- Printronix P-Series
- Printronix P-Series XQ
- Serial Matrix
- Proprinter III XL
- Epson FX-1050

LinePrinter Plus emulation provides portrait and landscape image orientation. Automatic 1-up, 2-up, 4-up, and gray bar overprinting are also provided. The emulation offers proportional (scalable) fonts and multi-up form definition capability as well.

Optional emulations are also available on diskette. Refer to Appendix A for a list of optional emulations. Refer to the *Programmer's Reference Manual* or *Operator's Guide* supplied with each emulation diskette for specific information.

Hardware Options

Ask your printer representative about these options which can enhance your printer's versatility:

- Paper stacker with printer stand

The paper stacker provides for properly stacked paper from the beginning to completion of the print job. The stacker will hold an entire box of media.

- Memory expansion (4 meg and 16 meg increments)

The L1024 has 8 meg of memory factory installed. Memory expansion modules are available in increments of either 4 or 16 meg. Using these modules, printer memory can be expanded to 40 meg.

- Second Floppy Disk Drive

A second floppy disk drive can be installed, as disk drive B.

- LAN connection

A hardware option is available for proper connection of the printer to a LAN.

- Coax/Twinax connection

A hardware option is available for proper connection of the printer for Coax/Twinax operation.

- Optional fonts

Optional printer fonts can be purchased and loaded into the printer using a diskette.

Fonts and Forms

The printer provides a variety of resident fonts. The available fonts are dependent the emulation used. For example, the Printronix LinePrinter Plus emulation provides Letter Gothic, Courier, OCR-A, and OCR-B as standard fonts sets.

Additional fonts can be loaded from the host computer or from optional font diskettes into printer memory. Once loaded, these additional fonts are accessed in the same way as the resident fonts. Printer languages that support downloaded fonts will not retain these fonts in memory when the printer is powered off.

Forms may be stored together with fonts. The storage space for forms and fonts depends on memory availability and diskette space. Different fonts and forms may be used depending on the emulation installed.

General Laser Printer Technology

The operation of a laser printer is somewhat different than that of an impact printer. They produce an entire page at once, compared to line printers, which produce complete character lines.

NOTE: If the software application fails to give a form feed at the end of the data, and the data does not exceed the selected lines per page setting, the page will not print. Rather, it will remain in memory.

The laser printer has two basic functional parts: the engine and the controller. The engine is responsible for the mechanical aspects of producing the page. The controller controls the printer and is responsible for electronic data manipulations.

NOTE: Laser printers can not print to the physical edge of the paper. If the document image runs to the edge of the paper, portions of the image may be lost.

The electrophotographic printing process, shown in Figure 1–2, consists of the following steps:

1. **Charging:** The charge corona is a thin wire electrode that extends across the width of the media. This electrode places a high-voltage electrostatic charge on the organic photoconductor (OPC) drum.
2. **Imaging:** Based on data received from the host computer, a bit-mapped image of the page is generated in random access memory (RAM) on the controller (not shown).
3. **Exposing:** The laser scanning unit (LSU) exposes areas of the OPC which are to be imaged (i.e., black). This forms a latent image of the bit-mapped data. This image is made up of charged and uncharged areas.
4. **Developing:** The latent image areas of the OPC attract toner from the developer unit to form the developed image on the OPC drum. Since the charged areas of the drum have the same charge as the toner, they repel the toner.

5. **Transferring:** Another thin wire electrode, the transfer corona, puts a high electrostatic charge on the paper. This charge attracts the toner, transferring the toner from the OPC drum to the paper.
6. **Fusing:** Heat and pressure rollers fuse the transferred image to the paper.
7. **Cleaning:** As the OPC drum continues to turn, erase lamps remove all residual electrostatic charge from the OPC. The cleaning unit then removes unused toner from the OPC.

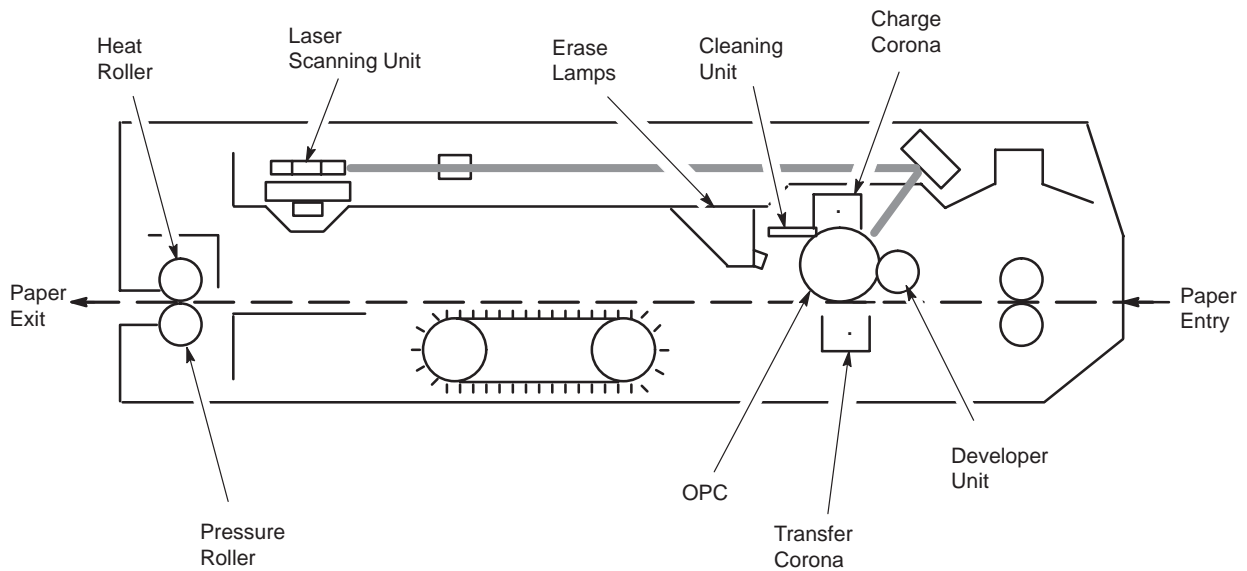

Figure 1-2. The Printing Process

2

Setting Up the Printer

Chapter Contents

Safety Precautions	2-2
Check the Power Requirements	2-3
Select a Site	2-4
Unpack the Printer	2-6
Initial Setup	2-7
Install the Developer Unit	2-10
Add the Starter Toner	2-11
Install the Ozone Filter	2-13
Install the Waste Toner Container	2-14
Install the Fuser Cleaner Felt	2-16
Install the OPC Drum Unit	2-17
Load Paper	2-18
Install the Emulation Boot Diskette	2-20
Cable Connections	2-21
Check for Interference	2-23
Transporting the Printer	2-24
Short Distance Transport	2-24
Long Distance Transport	2-25

Safety Precautions

WARNING

The use of controls or adjustments or the performance of procedures other than those specified in this manual may result in exposure to hazardous radiation.

WARNUNG

Die Nichtbeachtung der in diesem Handbuch dargelegten Punkte sowie die Verwendung anderer Kontroll- oder Steuereinrichtungen kann dazu führen, daß gefährliche Strahlung abgegeben wird.

ATTENTION

L'utilisation de commandes et réglages ou l'exécution de procédures autres que celles spécifiées dans ce manuel peuvent entraîner une exposition à des radiations dangereuses.

Be aware of components in the printer that are potentially hazardous or easily damaged. For example, the fuser unit becomes very hot under normal operating conditions, and several components use high voltage.

Observe the following precautions to ensure personal safety and proper installation and operation of the printer.

- Read all instructions.
- Save these instructions for later reference and use.
- Follow all warnings and instructions printed in this manual and marked on the printer.
- Keep combustible materials away from the printer.
- Provide adequate ventilation.
- Never push objects of any kind through the cabinet slots. They may contact dangerous voltage points or other hazards. Injury to the operator, damage to the printer, or fire could result.
- Never spill liquid of any kind on or in the printer. Use only cleaning agents and methods indicated in this manual.

- Make sure nothing rests on the power cord. Do not locate the power cord where people will walk on it. Do not place the power cord under any carpet.
- Do not lean or place heavy objects on top of the printer.

For additional requirements, refer to Appendix A.

Check the Power Requirements

WARNING

Do not connect the printer to the power source until instructed to do so and until all shipping restraints have been removed.

WARNUNG

Den Drucker nur unter Anleitung an die Stromquelle anschließen, und erst dann, wenn alle Versandmaterialien entfernt worden sind.

ATTENTION

A moins d'en avoir reçu l'ordre, ne pas brancher l'imprimante avant d'en avoir ôté tout le matériel d'emballage.

The printer must be connected to an acceptable AC power source; otherwise, the printer will not operate properly and may be damaged. The rear side panel label identifies the correct power source for the printer: either 100 to 120 VAC, 60 Hz or 220 to 240 VAC, 50 Hz.

The power source must be properly grounded. Since large power fluctuations can cause the printer to malfunction, it should be connected to a “noise-free” power source, not subject to surges or noise generated by motors, lighting, or air conditioning equipment on the same circuit. To allow for an adequate power cable run, the printer should be placed no more than eight feet (2.5 meters) from the power outlet.

Select a Site

When selecting the location for the printer, consider the following power requirements, interface requirements, and environmental factors:

- A proper power source must be available. (Complete power requirements are specified in the “Check Power Requirements” section on page 2–3.)
- The location must be within the maximum cable length specifications for the host computer interface.
- The temperature range should be +50°F to +90°F, with no sudden changes in temperature or humidity. The printer should be positioned away from any air drafts from heating or air conditioning ducts.
- Insure that the room provides adequate ventilation. The minimum room volume is 1000 cubic feet and must provide, at a minimum, one fresh air exchange every two hours.
- The location should provide enough space for maintenance and replacement of consumables (toner, developer, paper, etc.). Refer to Figure 2–1.
- The printer should not be exposed to direct sunlight or hot lighting equipment. This may cause an abnormal temperature rise in the printer and adversely affect its operation. If necessary, shade or screen the printer from such exposure.
- Avoid exposing the printer to any corrosive gases or vapors.
- Avoid installing the printer in an area subject to heavy vibrations.

For additional environmental requirements, refer to the *Introduction* chapter and to Appendix A.

Figure 2–1 illustrates spatial site requirements for the printer. The dimensions are listed in inches and include the requirements with the top and front covers open.

NOTE: The actual printer dimensions are shown in Figure 2–1. When installing the printer at your site, allow an additional 6 inches clearance behind the printer for connection of interface and power cables.

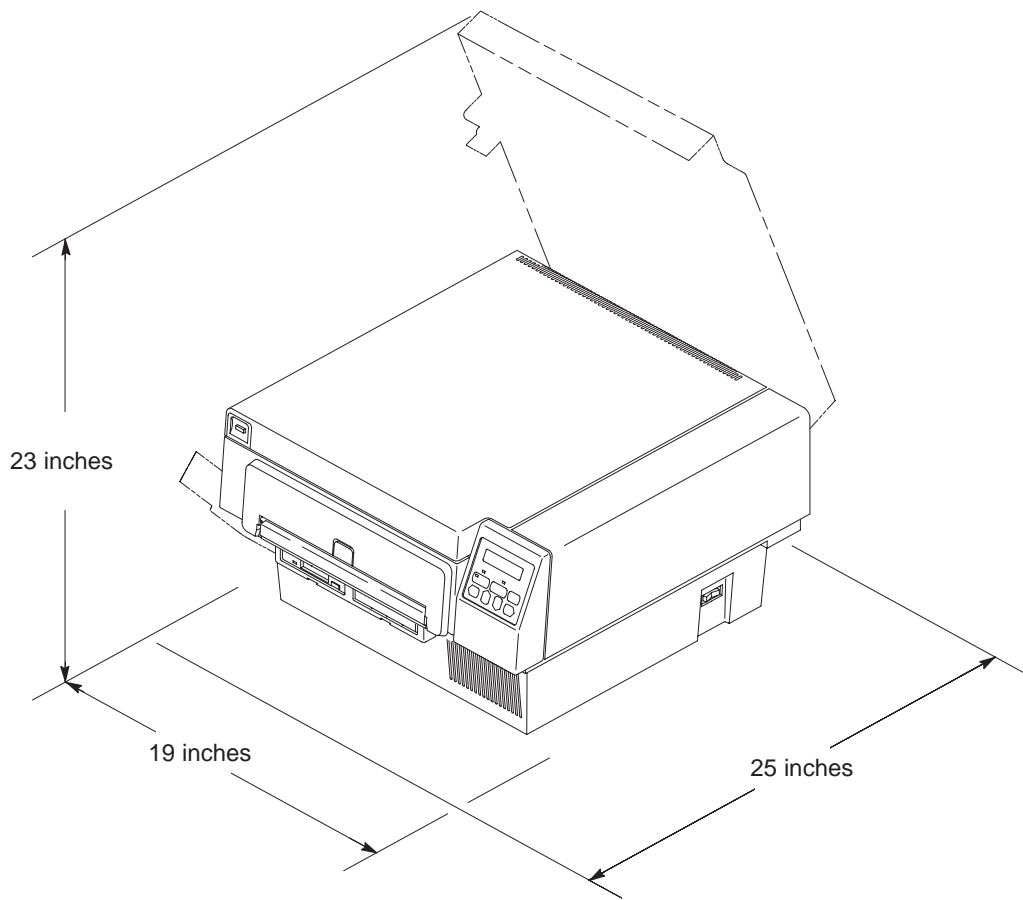

Figure 2-1. Clearance Requirements

Unpack the Printer

The printer is shipped in two cartons. The carton containing the consumables ship set is placed on top of the printer carton. The printer carton is shown in Figure 2–2 with all of the contents. The consumables ship set; which is made up of the toner kit, OPC cartridge, and developer kit, is shipped in its own carton (not shown in Figure 2–2), as shown in the figure below.

NOTE: Save the printer shipping materials in case they are needed to transport the printer to a new location.

NOTE: The material in the toner kit is recyclable. Save the toner box and packaging materials for recycling. A recycling shipping label, with instructions attached, is provided.

CAUTION

The OPC unit must be kept in its protective bag whenever the unit is not housed in the printer.

Carefully open each carton and examine contents for indication of damage during transport. Use care when lifting the printer from the shipping carton.

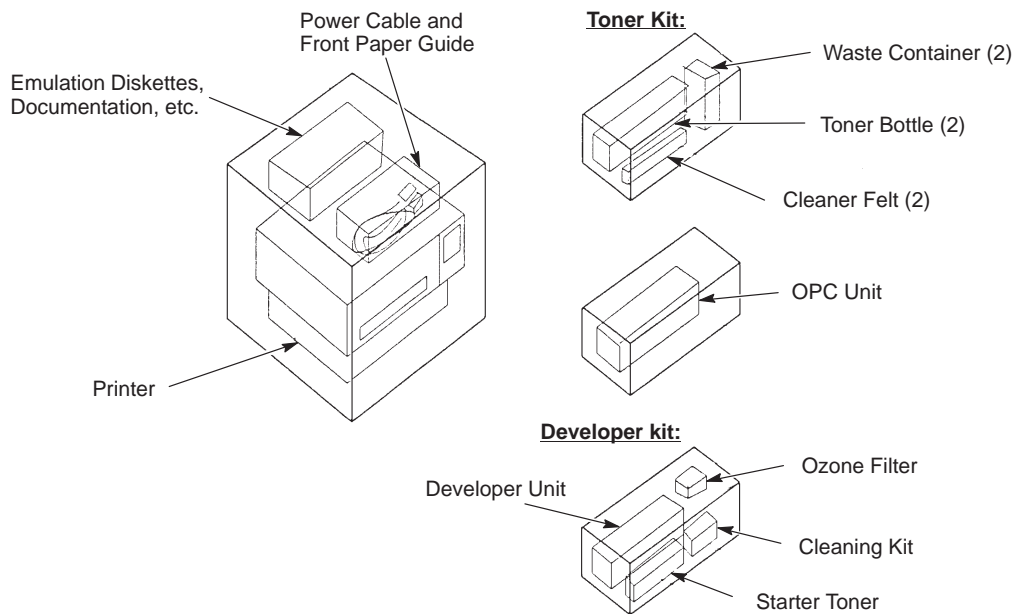

Figure 2–2. Unpacking the Printer

Initial Setup

To prepare the printer for operation, install the consumables that are packaged in consumable kits within the consumable ship set box. They are:

- Developer unit (Developer Kit)
- Starter Toner (Developer Kit)
- Ozone filter (Developer Kit)
- Waste toner container (Toner Kit)
- Fuser cleaner felt (Toner Kit)
- OPC drum unit

NOTE: The material in the toner kit is recyclable. Save the toner box and packaging materials for recycling. A recycling shipping label is provided with instructions attached.

To install the consumables, perform the following procedures in the order presented.

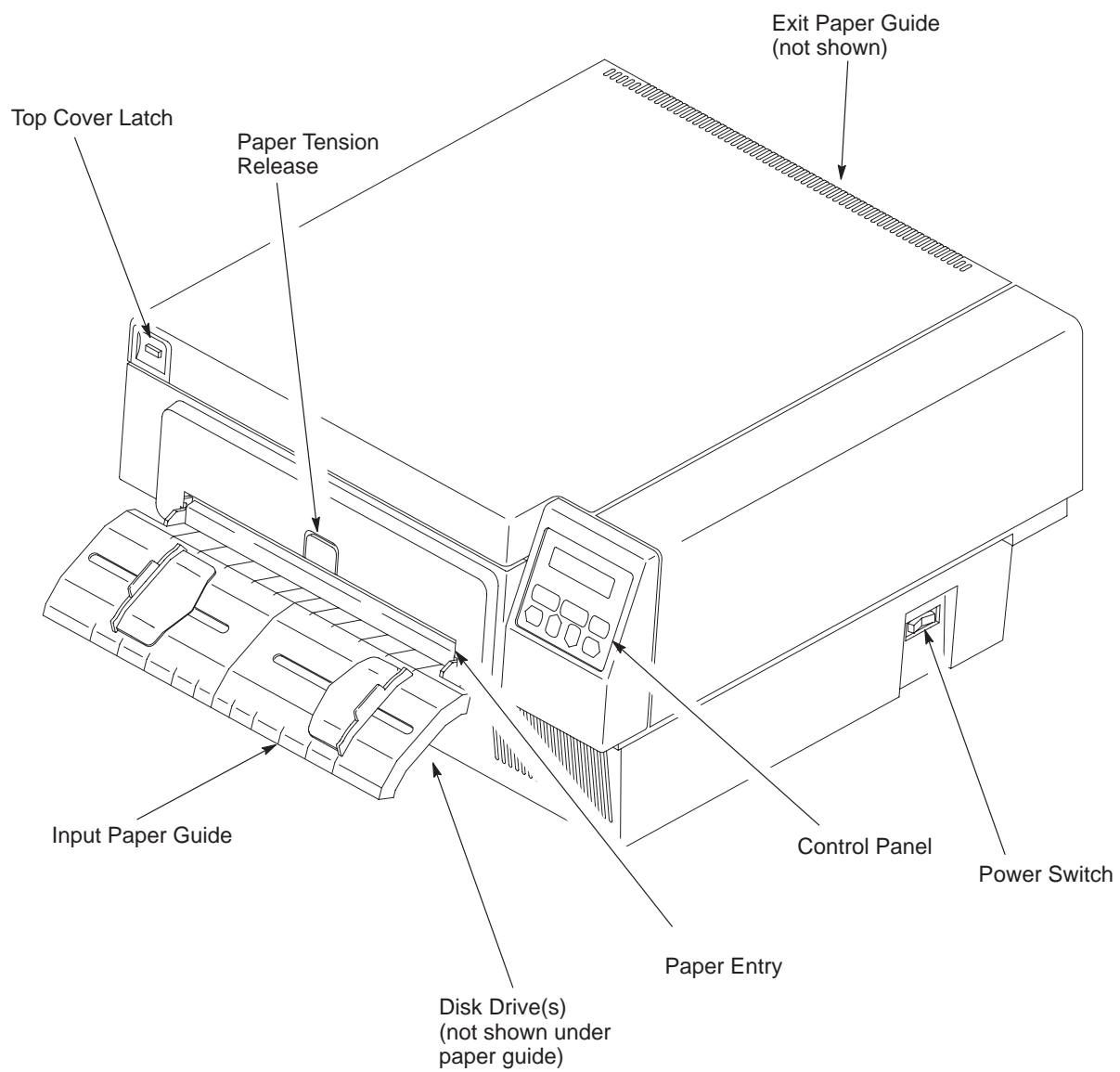

Figure 2-3. Front and Right Side View of Printer

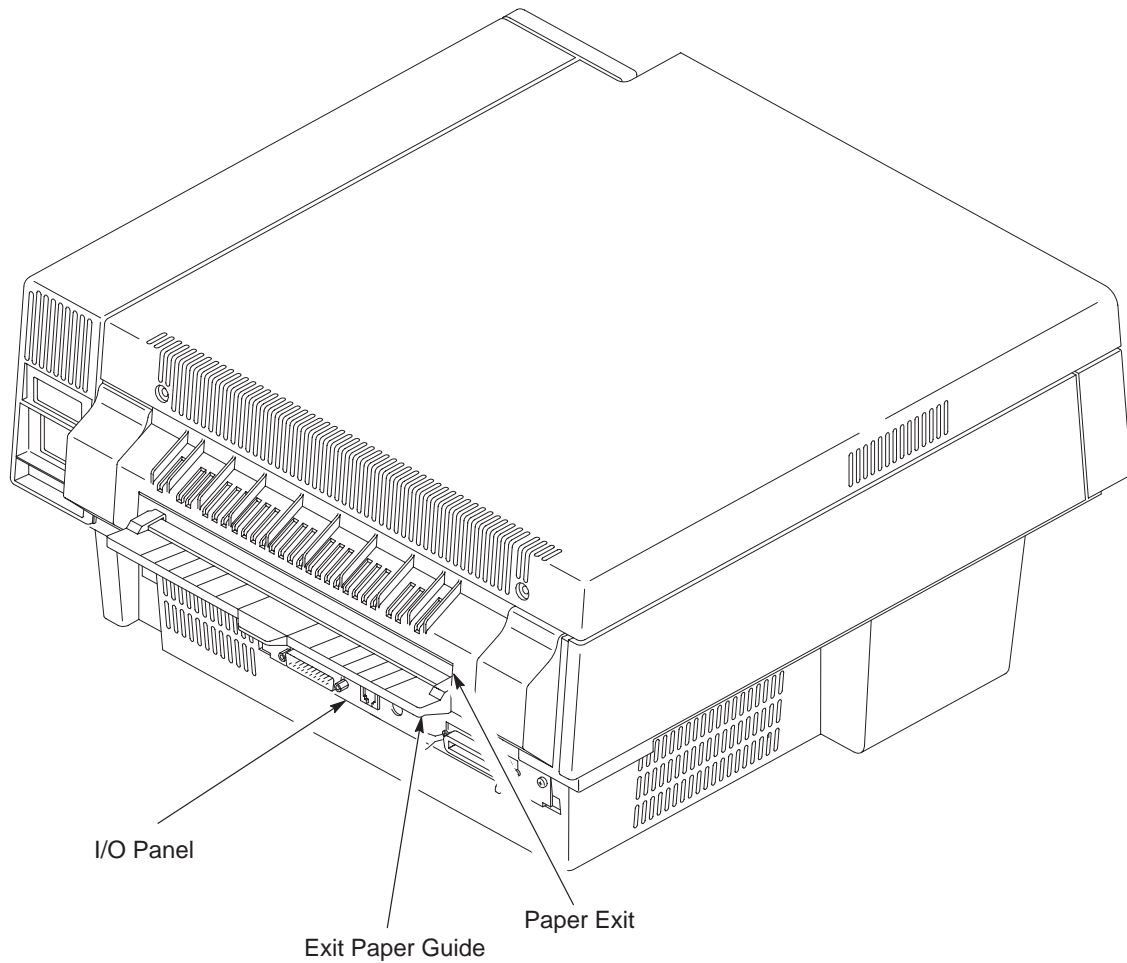

Figure 2-4. Rear and Left Side View of Printer

Install the Developer Unit

CAUTION

Perform this procedure *only* if this is the initial installation and no toner has been added to the developing unit. Otherwise, fill the toner hopper with toner from the toner bottle.

Refer to Figure 2–5 and perform the following steps:

1. Raise the top of the printer by firmly pressing the button on the left of the front panel.
2. Remove the new developer unit from its foil package.
3. Slide the developer unit along the plastic rails on either side of the printer until the developer unit is in position.
4. Lock the developer unit in place by pushing the two green lock-down clamps down until they click.

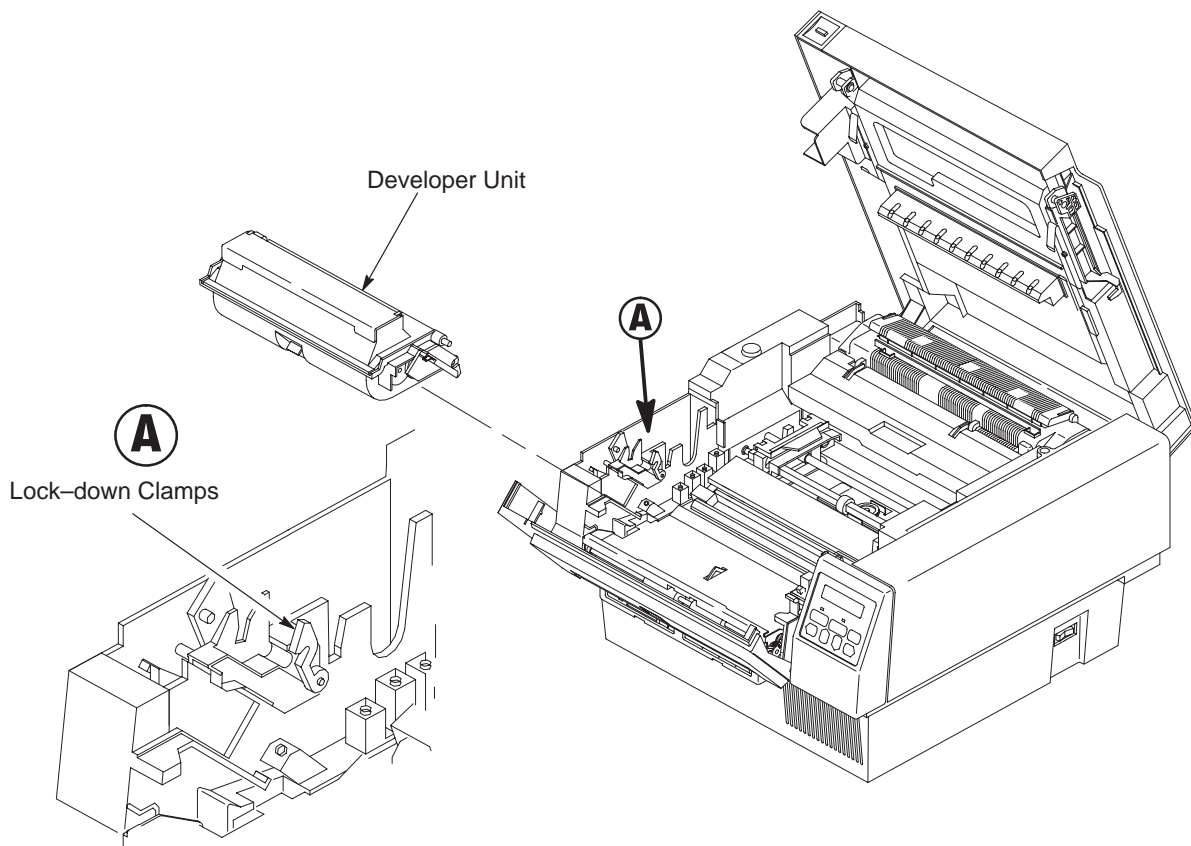

Figure 2–5. Installing the Developer Unit

Add the Starter Toner

IMPORTANT

For the initial installation, use the starter toner bottle from the developer kit. *Do not* use the toner bottles in the toner kit, which consists of two toner bottles, two fuser cleaner felts, and two waste toner containers.

After adding the starter toner, do not add toner from the toner kit until the printer displays a toner low message. Starter toner will provide approximately 200 pages of print at 5%.

Toner is light and easily becomes air-borne and can contaminate the printer. Be careful not to stain your hands, clothes, or the interior of the printer with toner.

NOTE: If toner is spilled, use a toner vacuum to clean up the loose toner. Do not use water to clean the toner from the printer. Any toner remaining on clothes can be removed with a cloth dampened in cold water. Never use hot water to remove toner from clothes or skin. Use care when handling toner.

When the toner is low, the printer will stop and the LCD will show “03 ADD TONER AND CHK WASTE BOTTLE.”

NOTE: Do not turn off the printer during a print job to add toner; otherwise, all unprinted data will be lost. Once the toner is added, press ON LINE to continue printing.

Refer to Figure 2–6 and perform these steps:

1. Open the starter toner bottle from the developer kit, and attach the spout.
2. Carefully open the developer unit cover.
3. Carefully pour the starter toner into the developer unit. Make sure to spread the toner evenly from side to side.

IMPORTANT

Do not squeeze the toner bottle as you pour the toner. Doing so could cause the loose toner to be blown out of the hopper and contaminate the printer and soil hands and clothes.

If the toner bottle does not empty completely, gently tap the end of the bottle while holding it over the hopper.

4. Close the developer unit cover. Press the cover until you hear a “click” which indicates that the developer unit is closed completely.
5. Clean up any toner that may have spilled during this process using one of the moist towels that come with the cleaning kit inside the developer kit.

NOTE: Some software stops communicating with the printer if the printer is off line for more than two minutes. In this case, you may need to restart your print job.

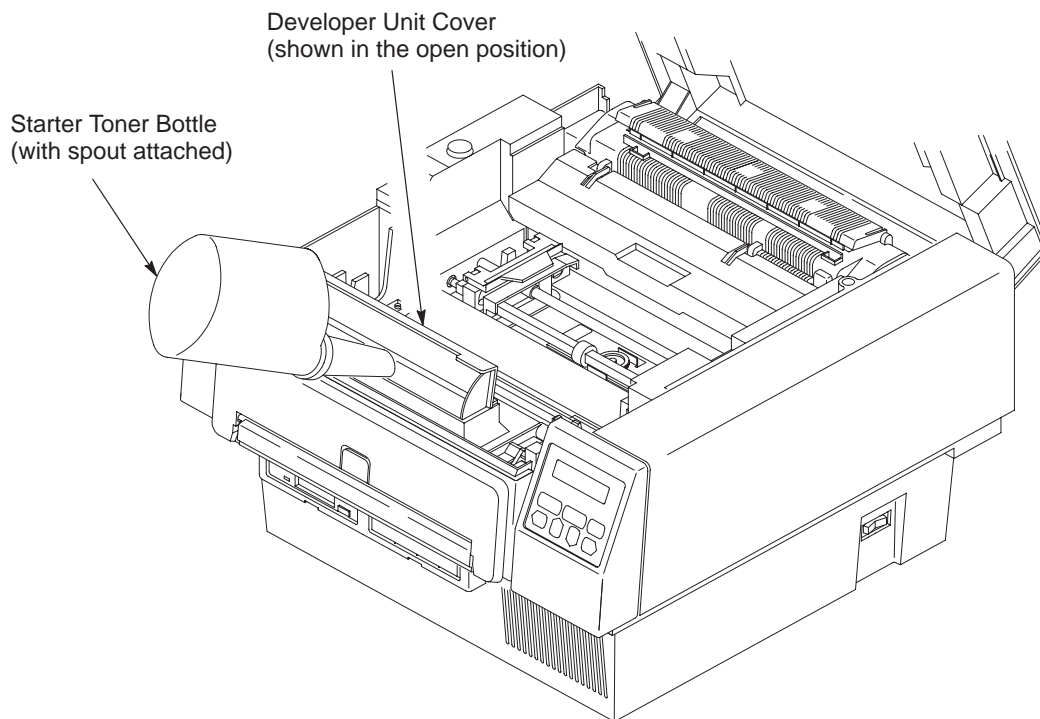

Figure 2-6. Filling the Toner Cartridge

Install the Ozone Filter

Refer to Figure 2-7 and perform the following steps:

1. Remove the ozone filter from the plastic bag.
2. Holding the ozone filter by its tab, place the ozone filter into the slot on the inside of the front of the printer.

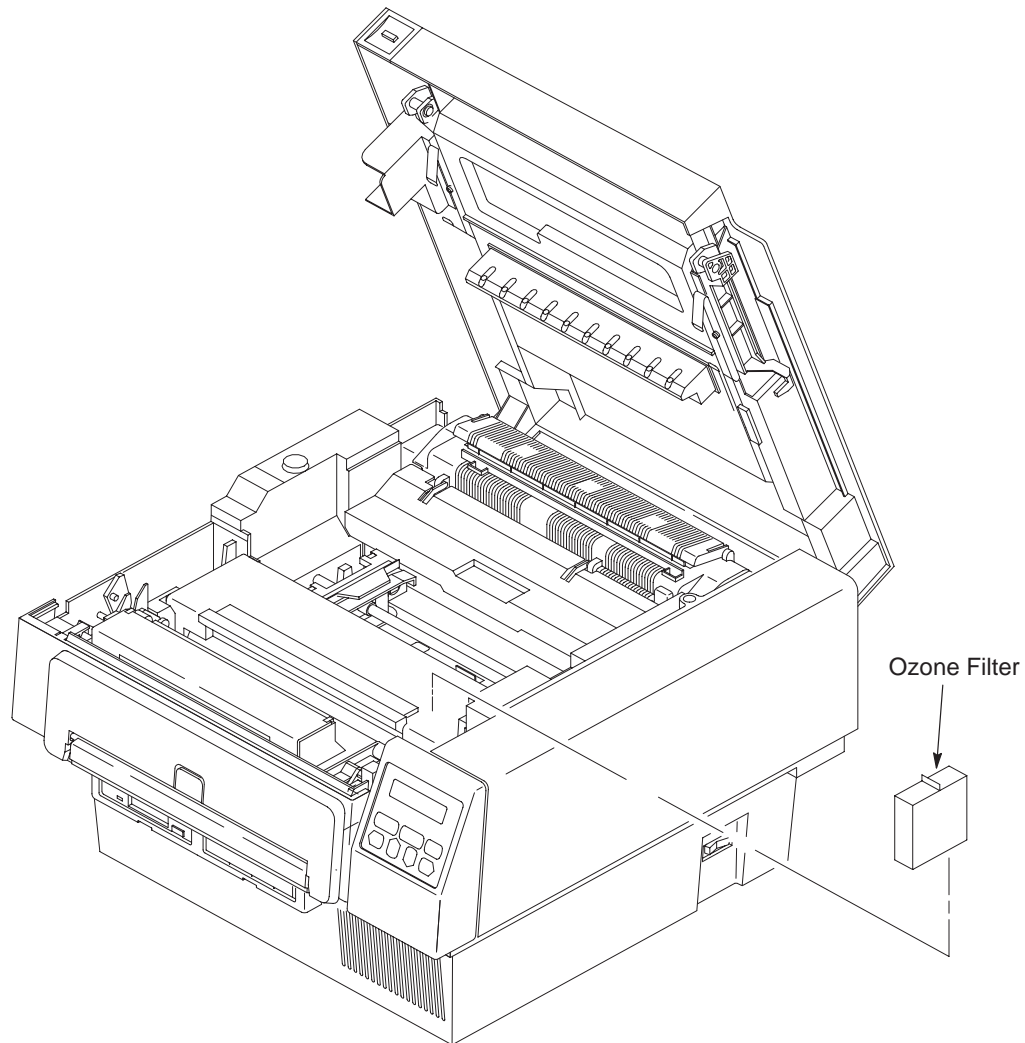

Figure 2-7. Installing the Ozone Filter

Install the Waste Toner Container

NOTE: The OPC drum unit must be removed before placing the waste toner container into its opening.

Refer to Figure 2–8 and perform these steps:

CAUTION

The OPC drum unit is light sensitive. Install it within five minutes. When removing the drum unit from the foil bag, *do not* touch the surface of the drum unit. Fingerprints and scratches can damage the drum surface and cause poor print quality. *Do not* rotate the drum unit manually. Forced rotation will cause an incorrect count for the life of the drum unit and may cause poor print quality.

1. If installed, remove the OPC unit by lifting it carefully out of the printer and place it on a flat surface.
2. Remove one of the waste toner containers from the toner kit box.

NOTE: If the green cap is placed on the filling hole, it cannot be removed, in which case the waste toner container should be discarded.

3. Make sure that the green cap is on the cap holder rather than on the filling hole of the new waste toner container.

NOTE: The waste toner container must be properly seated in the printer or the printer will display an error message when the printer cover is closed.

4. Install the waste toner container in the printer as shown in Figure 2–8.

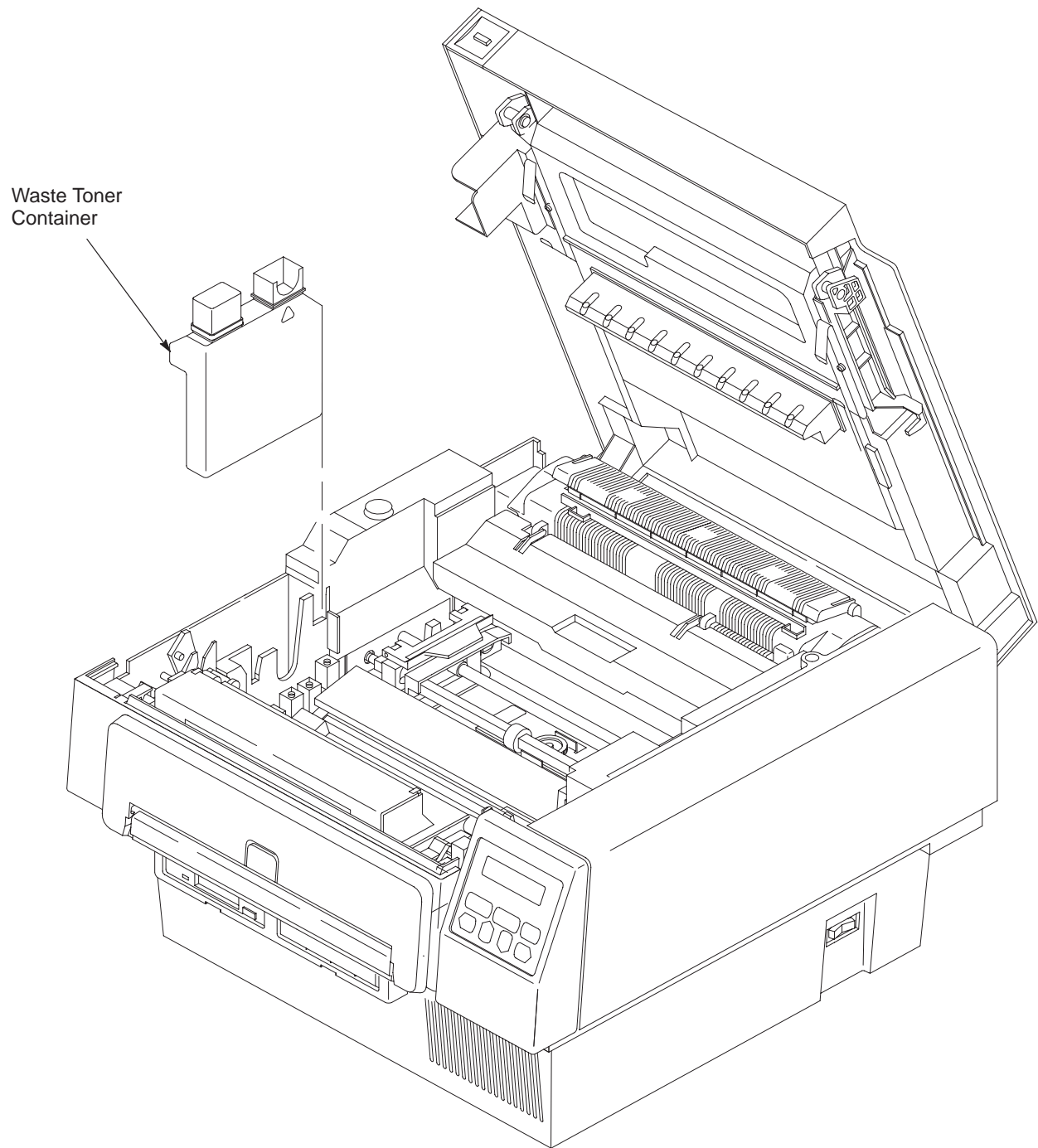

Figure 2-8. Installing the Waste Toner Cartridge

Install the Fuser Cleaner Felt

Refer to Figure 2–9 and perform these steps:

1. Remove one of the fuser cleaner felts from the toner kit box
2. Remove the fuser cleaner felt from its plastic wrapping.
3. Lift the cleaner felt cover on the fuser unit. If the cleaner felt cover comes off, simply slide the shafts into the appropriate openings in the fuser unit.
4. Carefully slide the fuser cleaner felt into the opening on the top of the fuser unit.
5. Close the cleaner felt cover.

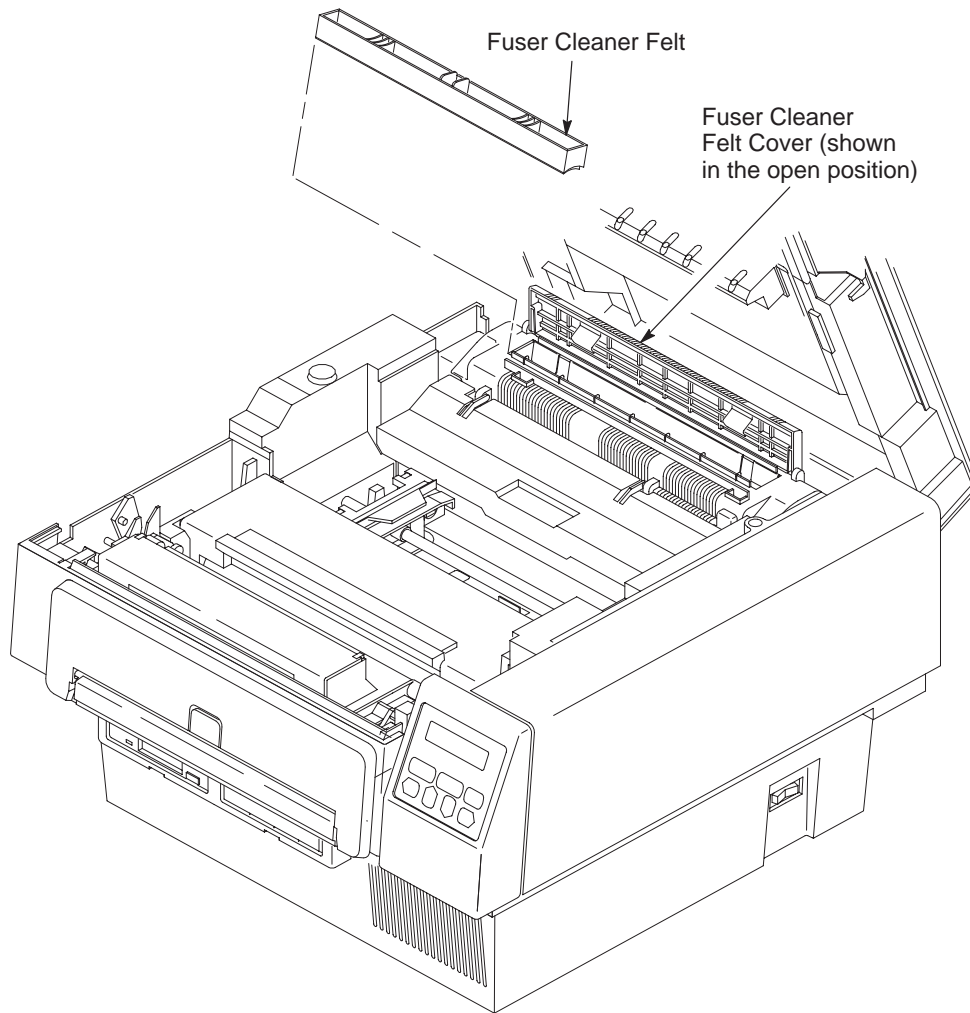

Figure 2–9. Installing the Fuser Cleaner Unit

Install the OPC Drum Unit

CAUTION

The OPC drum unit is light sensitive. Install it within five minutes. When removing the drum unit from the foil bag, *do not* touch the surface of the drum unit. Fingerprints and scratches can damage the drum surface and cause poor print quality. *Do not* rotate the drum unit manually. Forced rotation will cause an incorrect count for the life of the drum unit and may cause poor print quality.

Refer to Figure 2–10 and perform these steps:

1. Remove the OPC drum unit from its foil bag.

NOTE: Save the foil bag and insert the OPC drum unit into the bag whenever the printer cover is open for more than five minutes.

2. Insert the drum unit behind the developer unit. The OPC drum unit will slide into place easily.

NOTE: The drum unit does not lock into place; it rests behind the developer unit.

3. Close the printer cover.

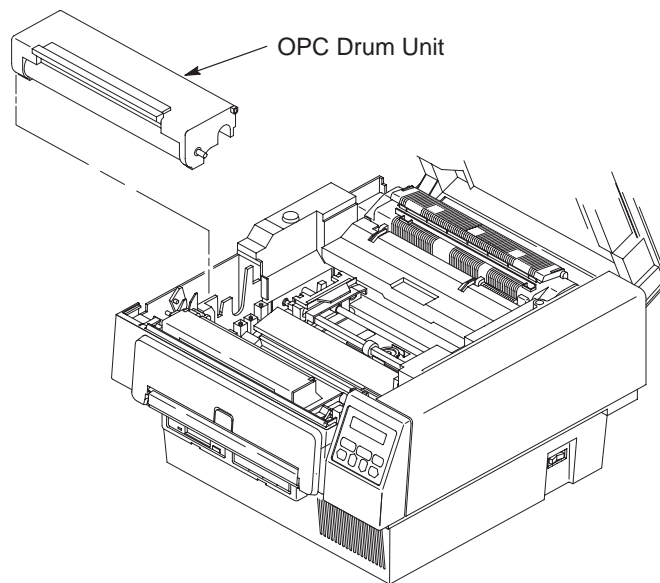

Figure 2–10. Installing the OPC Drum Unit

Load Paper

NOTE: Before loading paper, make sure the Paper Length and Paper Width options are set properly in the Paper Control configuration menu. Refer to the *Configuring the Printer* chapter, page 3–17, for details.

Refer to Figure 2–11 and perform the following steps:

1. Raise the top of the printer by firmly pressing the top cover latch on the left side of the front panel.
2. Insert paper into the front of the printer. Press the tension release as required to insert the paper.
3. Open the tractor gates on the tractor unit, place the paper on the pins, and close the tractor gates.
4. Unlock the tractors by pushing up the tractor locks.
5. Adjust the width of the tractors so that the paper is tight.
6. Lock the tractor unit by pushing down on the tractor locks.
7. To ensure that the printer will start at the top of a page, check the following:

The leading edge of the paper should be straight; not torn, crooked, or curled.

The leading edge of the paper should not extend beyond the tractors. This allows the printer to set the top of form accurately and automatically at the leading edge of the paper.

8. Close the top cover of the printer.

NOTE: Repeat the paper loading procedure whenever top of form must be reset (e.g., after clearing a paper jam, loading new paper, etc.). For details on clearing paper jams, refer to the *Diagnostics and Troubleshooting* chapter.

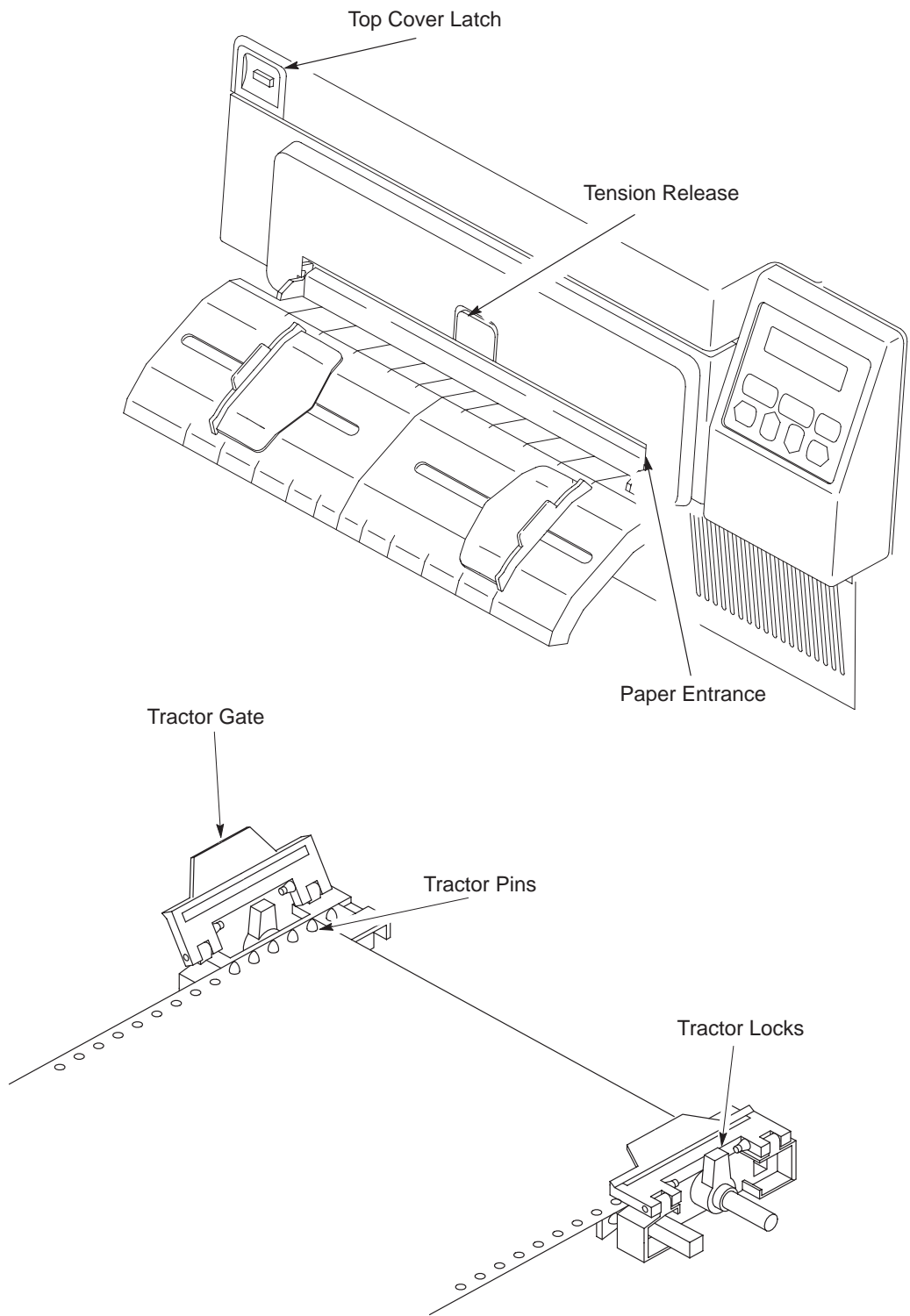

Figure 2-11. Loading Paper

Install the Emulation Boot Diskette

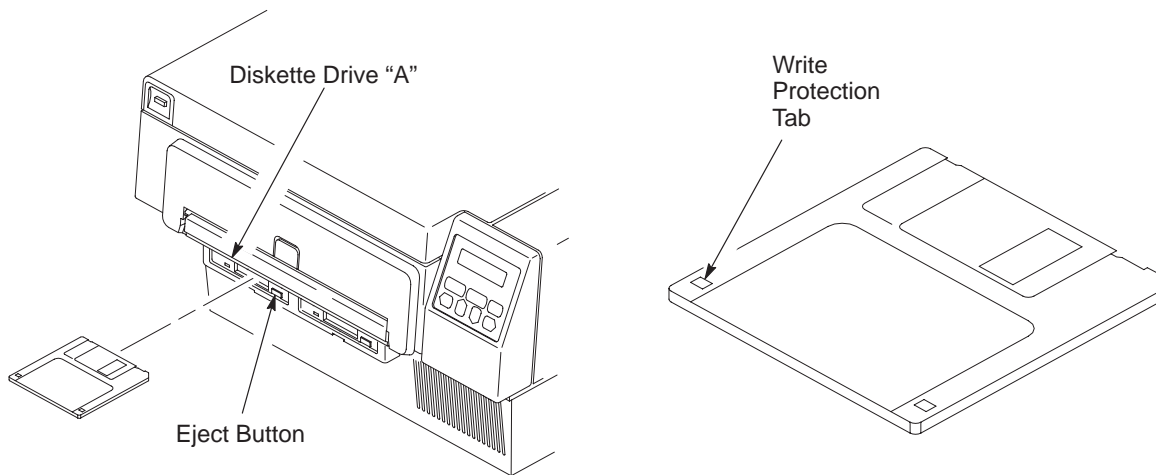

Figure 2–12. Installing the Diskette

1. Make sure the power switch on the printer is turned off.

CAUTION

Do not bend or touch exposed areas of the diskette. Keep the diskette away from magnetic fields. Do not store in especially cold (50° F) or hot (120° F) areas.

2. Remove the emulation boot diskette from its shipping container. Contact your vendor if the diskette is missing.
3. Make sure the diskette is not write-protected. The tab must be closed.
4. Insert the emulation boot diskette into drive A until it snaps into place.
5. If you are installing a font diskette, insert the diskette into drive B. Make sure this diskette is not write-protected. (The tab must be closed as shown in Figure 2–12.)

NOTE: The printer comes standard with one floppy disk drive. Certain optional software emulations, require two floppy disk drives. For software emulations requiring two floppy disks, insert the program disk into the Drive A and the fonts disk into Drive B.

Cable Connections

Now the printer can be connected to power and to your system. To connect the cables, refer to Figure 2–13 and perform the steps listed below.

WARNING

To prevent injury to yourself or damage to the printer, make sure the printer is connected to a proper power source.

WARNUNG

Um Personenschäden oder eine Beschädigung des Druckers zu verhindern, sicherstellen, daß der Drucker an eine geeignete Stromquelle angeschlossen ist.

ATTENTION

S'assurer que l'imprimante est branchée afin d'éviter tout risque de blessures corporelles ou de dommages à l'imprimante.

1. Verify that the site line voltage is the same as the voltage specified in “Check the Power Requirements” section, page 2–3.
2. Make sure the printer power switch is set to 0 (OFF).
3. Connect the power cord (supplied with the printer) to the AC power connector on the printer.

NOTE: To avoid possible electrical interference, separate the AC power cord and the interface cable.

4. Connect the opposite end of the power cord to the AC line receptacle.
5. Connect the interface cable to the appropriate printer interface connector and to the host computer. The printer supports a variety of standard and optional interfaces:
 - Centronics parallel
 - Dataproducts parallel (requires optional cable adapter)
 - RS–232 and RS–422 serial
 - Coax/Twinax (option)
 - Local Area Network (option)

NOTE: RS-422 can be enabled or disabled via a menu option on the control panel under the host interface selection. Make sure this selection is properly made for your application.

NOTE: The printer must be properly configured for the appropriate interface. Refer to the *Configuring the Printer* chapter for more information.

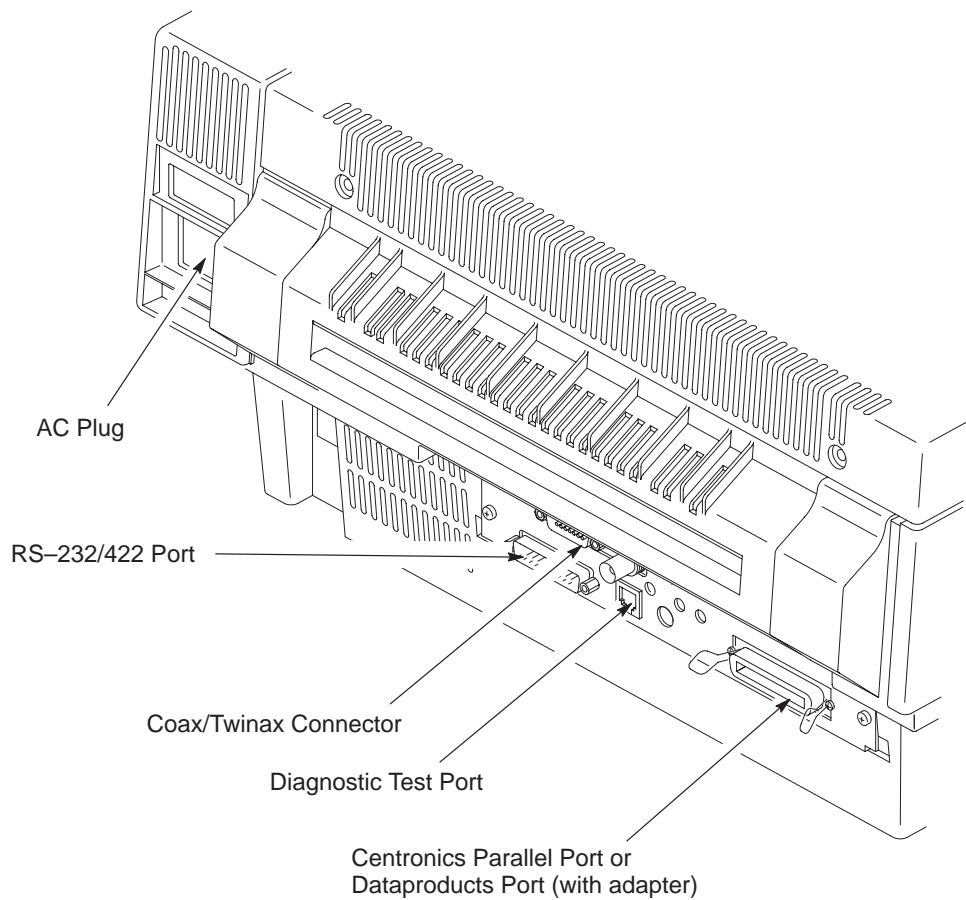

Figure 2-13. Cable Connections

Check for Interference

The printer should be used only with FCC, VDE, or CE certified computing devices. If the printer is installed within 10 feet of audio or video equipment, interference may occur. Determine if there is interference by turning the printer ON and OFF and checking the audio and video equipment for noise spikes. If interference occurs, perform the following:

1. Relocate the printer or the electronic device affected by the interference, including the antenna, if applicable.
2. Ensure that the printer and electronic device are on separate power circuits or install AC line filters.
3. Ensure that the wall outlets are properly grounded.

If these steps do not resolve the problem, refer to the Federal Communications Commission Booklet, “How to Identify and Resolve Radio – TV Interference Problems” (stock number: 004–000–00345–4), available through the U.S. Government Printing Office, Washington, D.C. 20402.

Transporting the Printer

Take precautions to prevent damage to the printer during transport. If a move requires trucking, use the original packaging materials.

Short Distance Transport

1. Turn off the printer and unplug the power cord from the wall outlet.
2. Remove the paper.
3. Remove all external communication and interconnection cables (AC line cord, coax cable, any optional attachment cards, etc.) from the printer.
4. Before you remove the developer unit, place several sheets of paper in front of the printer and on a work surface that you will set the developer on. Do this in case any toner spills.
5. Remove the developer unit. (It is a good idea to have a toner vacuum handy when performing this step.)
6. Place the developer unit in a sealable plastic bag.
7. Temporarily remove the OPC drum in order to remove the waste toner container.

NOTE: The waste toner container is recyclable. A recycling shipping label is provided, with instructions attached, in the toner box.

8. Place the green cap on the filler hole of the waste toner container and remove it from the printer and package it for recycling.
9. Install the OPC Drum in the printer.

CAUTION

Do not touch exposed areas of or bend the diskette. Keep the diskette away from magnetic fields. Do not store in especially cold (50°F) or hot (120°F) areas.

10. Remove the diskette from the disk drive and place it in a protective cover.
11. Always carry the printer and developer unit upright.

Long Distance Transport

1. Pack all connecting cables in a plastic bag.
2. Place the developer unit in appropriate packaging for recycling. It is not practical to move the developer unit over long distances.
3. Using a towel and a toner vacuum, remove residual toner from inside the printer.

CAUTION

Failure to secure the pressure roller for shipment can cause permanent damage to the printer.

The fuser must be cool before proceeding further.

4. Secure the fuser pressure roller (lower roller) to prevent it from bouncing during shipment. Insert the original foam pad between the fuser rollers.

NOTE: If the original foam pad is not available for use, use bubble wrap or other foam packing material to secure the lower fuser roller.

NOTE: Replacement packaging material can be procured from your authorized representative.

5. Use original packing material if available. Otherwise, use sufficient shock-absorbing packaging material.
6. Secure the top and front covers to keep them from opening.
7. At the new site, install a new developer unit and waste toner container.

3

Configuring the Printer

Chapter Contents

Overview	3-4
Changing Printer Settings	3-5
Saving a Configuration	3-7
Modifying a Configuration	3-10
Printing a Configuration	3-13
Factory Settings	3-14
Configuration Menus	3-16
Paper Control Menu	3-17
Image Width	3-18
Paper Length	3-18
Horiz. Image Shift	3-18
Vert. Image Shift	3-18
Reprint on Fault	3-18
Printer Control Menu	3-19
Fuser Temperature	3-20
Energy Timeout	3-20
Diagnostics Menu	3-21

Test Print	3-22
Engine Life Data	3-22
Disk Management Menu	3-23
Load Configuration	3-24
Save Configuration	3-24
Print Configuration	3-24
Delete Configuration	3-25
Power-up Configuration	3-25
Protect Configurations	3-25
Mode (Emulation) Menu	3-26
Impact Printer	3-27
PCL5	3-27
IGP/PGL	3-27
IGP/VGL	3-28
CTHI	3-28
IPDS	3-28
Maintenance/Miscellaneous Menu	3-29
Panel Key Sound	3-29
Alarm	3-29
Power-up State	3-29
Hex Dump Mode	3-30
PTX-Setup Option	3-31
Display Language	3-31
Host Interface Menu	3-32

Centronics Interface Parameters	3-33
Dataproducts Interface Parameters	3-36
Serial Interface Parameters	3-39
Font Memory Menu	3-44
Maximum Character Memory	3-45
Maximum Cache Memory	3-45
Maximum Cache Size	3-46
Maximum Cached Characters	3-46
Maximum Fonts Loaded	3-46
Font Weight	3-47
System Information Menu	3-48
System Memory	3-48

Overview

The configuration process is matching the printer operating characteristics to those of the host computer.

This chapter explains how to use the control panel to change individual settings and save them as a customized configuration.

Figure 3–1 shows an overview of the configuration menu. The next pages describe how to move within the menu, change configuration settings, and save and print configurations. This is the menu structure for the LinePrinter Plus emulation. (Menu options are explained beginning on page 3–16.)

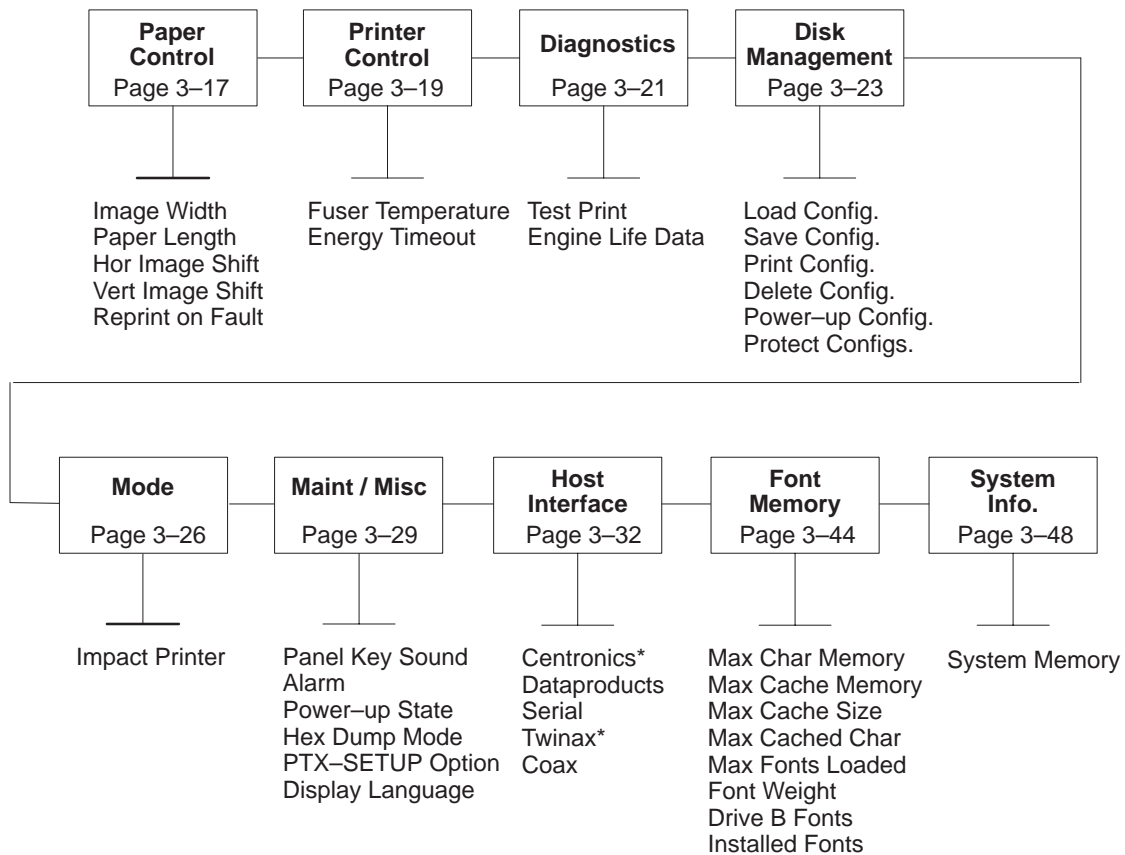

Note: If the Twinax interface is supported Twinax is the factory default. If Twinax is not supported, Centronics is the default.

Figure 3–1. The Configuration Menu

Changing Printer Settings

Changing printer settings, such as paper length, emulation, and host I/O interface, is referred to as configuring. You configure the printer using the control panel.

1. Make sure the printer is offline. If ONLINE is lit, press ON LINE.

OFFLINE
PAPER CONTROL

2. Press NEXT or PREV to cycle through these menus:

Paper Control
Printer Control
Diagnostics
Disk Management
Mode
Maint./Misc.
Host Interface
Font Memory
System Info.

3. When the desired menu is displayed, press DOWN to access the available options or submenus for that menu.
4. Press NEXT or PREV to scroll through the values.
5. Press ENTER to select a value. An asterisk is displayed next to the selected value.

NOTE: The ENTER switch must be *unlocked* to change printer settings. The default at power-up is the “LOCKED” state. If the ENTER switch has been locked, you must unlock it before the printer will accept the new parameter setting. Press UP and DOWN simultaneously to toggle between lock and unlock. When ENTER is unlocked, the display will momentarily flash:

ENTER SWITCH
UNLOCKED

6. If there are more values you want to change, use the UP, DOWN, NEXT and PREV switches to access the value and press ENTER to select it.
7. At any time, you may press UP to return to the options one level higher.
8. At any time, you may also press ON LINE to save your changes temporarily, exit the configuration menu, and place the printer *online*.
9. Once you have finished selecting all of your options, you can save your configuration for later access. Save the configuration as described on page 3-7, if desired.

IMPORTANT

If you do not save your configuration, all of the new values will be lost when you turn off the printer. (Refer to “Disk Management Menu” on page 3-23.)

Saving a Configuration

You can save up to eight different configurations to meet unique print job requirements.

For example:

Config. 0: Factory Default (This cannot be altered. See page 3–14.)

Config. 1: Selects RS–232 Serial Interface
Selects Image Width of 4 inches
Selects Paper Length of 24 inches
Selects Image Shift of 1 inch, etc.

Config. 2: Selects Dataproducts Parallel Interface
Selects Image Width of 8 inches
Selects Paper Length of 11 inches
Selects Image Shift of 3/20 inch, etc.

The configurations are saved and stored on diskette for later use. These configurations, including the factory default, will not be affected when the printer power is turned off. If you do not save your configuration before you turn off the printer, the current configuration will be lost.

NOTE: If the “Protect Configs.” option is enabled, the new configuration will not be saved unless the existing configuration has been deleted. Refer to page 3–25 for details.

Follow these steps to save a new configuration:

1. Press ON LINE to take the printer offline.



OFFLINE
PAPER CONTROL

2. Press NEXT or PREV until the following is displayed:



OFFLINE
DISK MANAGEMENT

3. Press DOWN.

4. Press NEXT or PREV until the following is displayed:

DISK MANAGEMENT
Save Config.

5. Press DOWN.
6. Press NEXT or PREV to cycle through the options (1–8).

NOTE: Configuration “0” does not appear in this list. It is the default configuration and can not be altered.

NOTE: If the “Protect Configs.” option is not enabled, the number configuration selected will be erased in order to write the current configuration. Make sure the number selected is empty or no longer required before making this selection.

7. When the desired number is displayed, press ENTER to select it.

If the configuration number has been previously saved *and* the “Protect Configs.” option is enabled, the following error message is displayed briefly:

CFG FILE EXISTS
DELETE FIRST

If the configuration number has not been previously saved *or* the “Protect Configs.” option is disabled, the JOB IN PROCESS light flashes and the following is displayed briefly:

STANDBY . . .

The following is displayed to indicate the configuration is being saved:

Save Config.
(selected number) *

8. It is recommended you print the configuration and store it in a safe place for future reference. Refer to page 3-13 for details on printing the configuration.

NOTE: If you want to make these new configuration parameters active at printer power-up, make sure you select this configuration as the “power-up config” (page 3-25).

Modifying a Configuration

You can change a saved configuration by “writing” over it. For example, you can modify Config. 1, shown below. Suppose you want to keep all settings except the interface type (e.g., you want to change RS-232 to Centronics). It is necessary to load a configuration, make the desired changes, delete the current “copy” of the configuration, and save the current machine configuration (in this example, configuration 1 with the desired changes) as the newly modified configuration.

Config. 1: Selects RS-232 Serial Interface
 Selects Image Width of 4 inches
 Selects Paper Length of 24 inches
 Selects Image Shift of 1 inch, etc.

1. Load the configuration to be changed (for example, Config. 1).
 - a. Press ON LINE to take the printer offline.

OFFLINE
PAPER CONTROL

- b. Press NEXT or PREV until the following is displayed:

OFFLINE
DISK MANAGEMENT

- c. Press DOWN.
 - d. Press NEXT or PREV until the following is displayed:

DISK MANAGEMENT
Load Config.

- e. Press DOWN.
 - f. Press NEXT or PREV to cycle through the options (0-8).

NOTE: Configuration “0” is the factory default configuration and cannot be altered.

- g. When the desired number is displayed, press ENTER to make the selection. The JOB IN PROCESS light flashes and the following is displayed briefly:

STANDBY . . .

The following is displayed to indicate the configuration is being loaded:

Load Config.
(selected number) *

2. Move through the menu and change all the desired values. (In this example, you would change the interface type value from Serial to Centronics.)
3. Press ENTER to save each new value. An asterisk is displayed next to the selected value.
4. Before saving the modified configuration, you must delete the original.
 - a. Press ON LINE to take the printer offline.

OFFLINE
PAPER CONTROL

- b. Press NEXT or PREV until the following is displayed:

OFFLINE
DISK MANAGEMENT

- c. Press DOWN.
 - d. Press NEXT or PREV until the following is displayed:

DISK MANAGEMENT
Delete Config.

- e. Press DOWN.
- f. Press NEXT or PREV to cycle through the options (1–8).
When the desired number is displayed (e.g., 1), press ENTER to select it. The JOB IN PROCESS light flashes and the following is displayed briefly:

STANDBY . . .

Then, the following is displayed to indicate the configuration is being deleted:

Delete Config.
1 *

- 5. Save the new configuration as described on page 3–7. Make sure you select the same number (e.g., Config. 1) when saving the modified configuration. The new configuration replaces the existing one.
- 6. Print a copy of this newest configuration and store it in a safe place. Refer to page 3–13 for details.

NOTE: If you want to make these new configuration parameters active at printer power-up, make sure you select this configuration as the “power-up config” (page 3–25).

Printing a Configuration

It is recommended that you print and store your configurations for future reference. The printout provides a list of the parameters you set when you created this configuration.

To print a configuration:

1. Press ON LINE to take the printer offline.



OFFLINE
PAPER CONTROL

2. Press NEXT or PREV until the following is displayed:



OFFLINE
DISK MANAGEMENT

3. Press DOWN.
4. Press NEXT or PREV until the following is displayed:



DISK MANAGEMENT
Print Config.

5. Press DOWN.
6. Press NEXT or PREV to cycle through the following printout options:

Current
Factory (this is 0)
Power-up
All
1-8 customized configurations

7. When the desired option is displayed, press ENTER. The JOB IN PROCESS light flashes and the printer prints the specified configuration.

Factory Settings

Table 3–1 lists the the factory default settings (i.e., Config. 0). These values are available for loading at any time, and are maintained in the printer until a new configuration is loaded.

Table 3–1. Factory Settings

Paper Control	
Image Width	8.2 inches
Paper Length	11.0 inches
Hor Image Shift	3/20 inches
Vert Image Shift	0/100 inches
Reprint on Fault	Enabled
Mode	Impact Printer (Refer to the <i>Impact Printer User's Manual</i> for defaults.)
Impact Printer	
PCL5 (optional)	
IGP/PGL (optional)	
IGP/VGL (optional)	
CTHI (optional)	
IPDS (optional)	
Maint / Misc	
Panel Key Sound	On
Alarm	On
Power-up State	Online
Hex Dump Mode	Disable
PTX_SETUP Option	
SETUP PARSE	Enable
SETUP SFCC	21h
Display Language	English
Host Interface	Twinax or Centronics
Centronics	
Data Bit 8	Enable
Paper Inst Line	Disable
Data Polarity	Standard
Strobe Polarity	Standard
Output Polarity	Standard
Paper Instruction Polarity	Standard
Strobe Filter	Enable
Fast Busy	Enable
Trailing Edge	Enable

Dataproducts	
Data Bit 8	Enable
Paper Instruction Line	Disable
Data Polarity	Standard
Strobe Polarity	Standard
Output Polarity	Standard
Paper Instruction Polarity	Standard
Strobe Filter	Enable
Trailing Edge	Enable
Serial	
Host Protocol	None
Baud Rate	9600 baud
Data Bits	8 bits
Stop Bits	1 bit
Parity	None
DTR Function	On/Offline and Buffer
RTS Function	On/Offline and Buffer
DTR Polarity	Normal
RTS Polarity	Normal
Buffer Size	8192 bytes
Number of Buffers	2 buffers
FIFO Trigger	14 bytes
Diagnostic	None
Series 1 Poll	0
Series 1 Delay	0+ Msec
Series 1 Idle	Disable
RS-422 Input	Disable
Font Memory	
Maximum Character Memory	300 KBytes
Maximum Cache Memory	200 KBytes
Maximum Cache Size	900 characters
Maximum Cached Characters	1 KBytes
Maximum Fonts Loaded	5 fonts
Font Weight	
Standard Characters	168
Bold Characters	218
Extra Bold Characters	259

Configuration Menus

The printer provides the following “main level” configuration menus:

- Paper Control
- Printer Control
- Diagnostics
- Disk Management
- Mode (Emulation)
- Maintenance/Miscellaneous
- Host Interface
- Font Memory
- System Information

The following pages show the configuration menus and describe the options.

Paper Control Menu

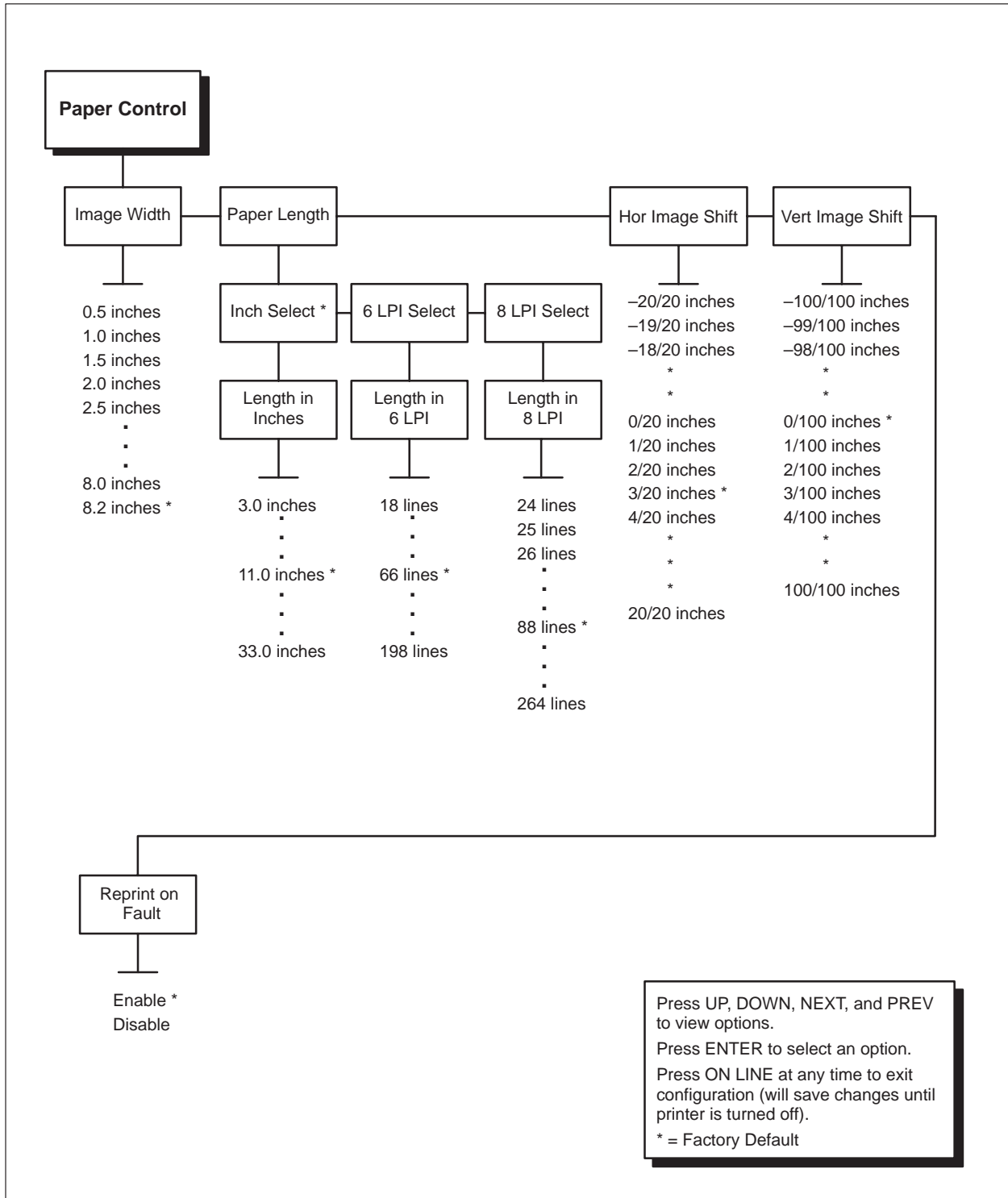

Figure 3–2. Paper Control Menu

Image Width

This option specifies the width of the image to be printed. The allowable range is 0.5 to 8.2 inches. The factory default value is 8.2 inches.

NOTE: If the paper width is less than 8.2 inches, you *must* set this parameter for proper positioning of the image on the paper.

Paper Length

This option specifies the vertical perf-to-perf distance of the continuous-form paper (i.e., the physical form length). The paper length may be specified in three different units:

Inches: 3.0 to 33.0 inches, in 1/2-inch increments (default: 11")

6 LPI: 6 to 198 lines, in 1-line increments (default: 66 lines)

8 LPI: 8 to 264 lines, in 1-line increments (default: 88 lines)

The printer can move paper in 1/6 or 1/8 inch increments. Therefore, the printer will always move paper the exact distance specified from this option.

Horizontal Image Shift

This option specifies the amount to shift an image to the right for precise positioning on the page. The actual width of the image is not affected by this parameter. The allowable range is 0.0 to 1.0 inch, in 1/20-inch increments. The factory default is 3/20 inch.

Vertical Image Shift

This option specifies the amount to shift an image down for precise positioning on the page. The actual length of the image is not affected by this parameter. The allowable range is 0.0 to 1.0 inch, in 1/100-inch increments. The factory default is 0/100 inch.

Reprint on Fault

The printer stops processing of a print image when the printer experiences a fault condition. Enable the reprint on fault option so the printer will process the entire image page that was being printed when the fault occurred. This option verifies that a printer fault will not interfere with the printing of an entire document.

Printer Control Menu

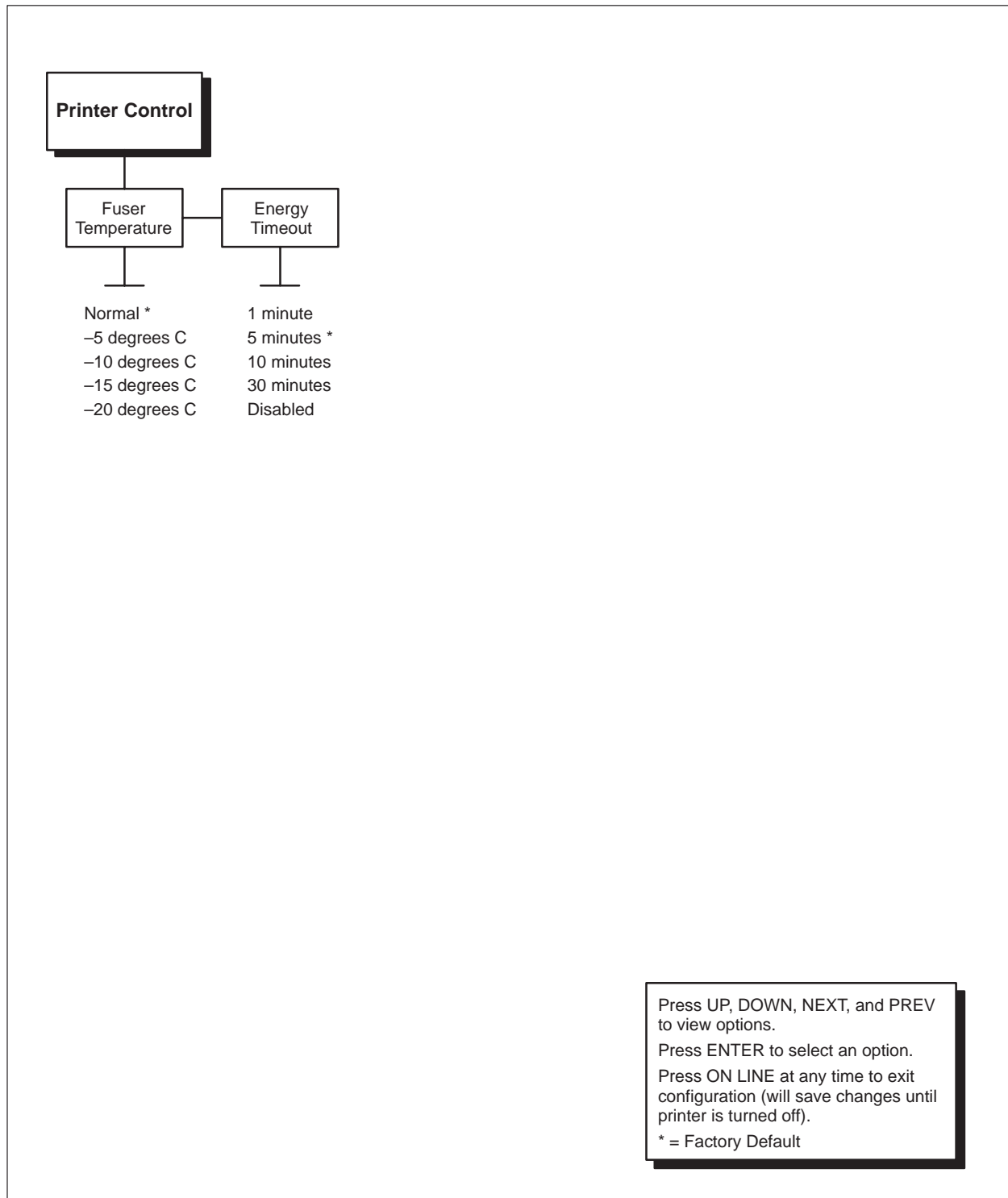

Figure 3–3. Printer Control Menu

Fuser Temperature

The fuser temperature option allows you to reduce the normal temperature of the fuser by up to –20 C in 5 degree increments. This reduction can be required due to the print media. For example, thinner material may curl or waffle at high temperatures and adhesive material on label material may melt. It is necessary to lower fuser temperature in such cases.

The selections on the control panel are:

Normal (this is the default selection)

–5 degrees C

–10 degrees C

–15 degrees C

–20 degrees C

Energy Timeout

The energy timeout option provides the ability to select the length of time before the printer goes into the energy saving mode. From the energy saving mode, the printer will require warm up time to bring the fuser to the configured temperature. Energy is saved by turning off heater power to the fuser.

The timeout selections are:

1 minutes

5 minutes (this is the default selection)

10 minutes

30 minutes

Disabled

Diagnostics Menu

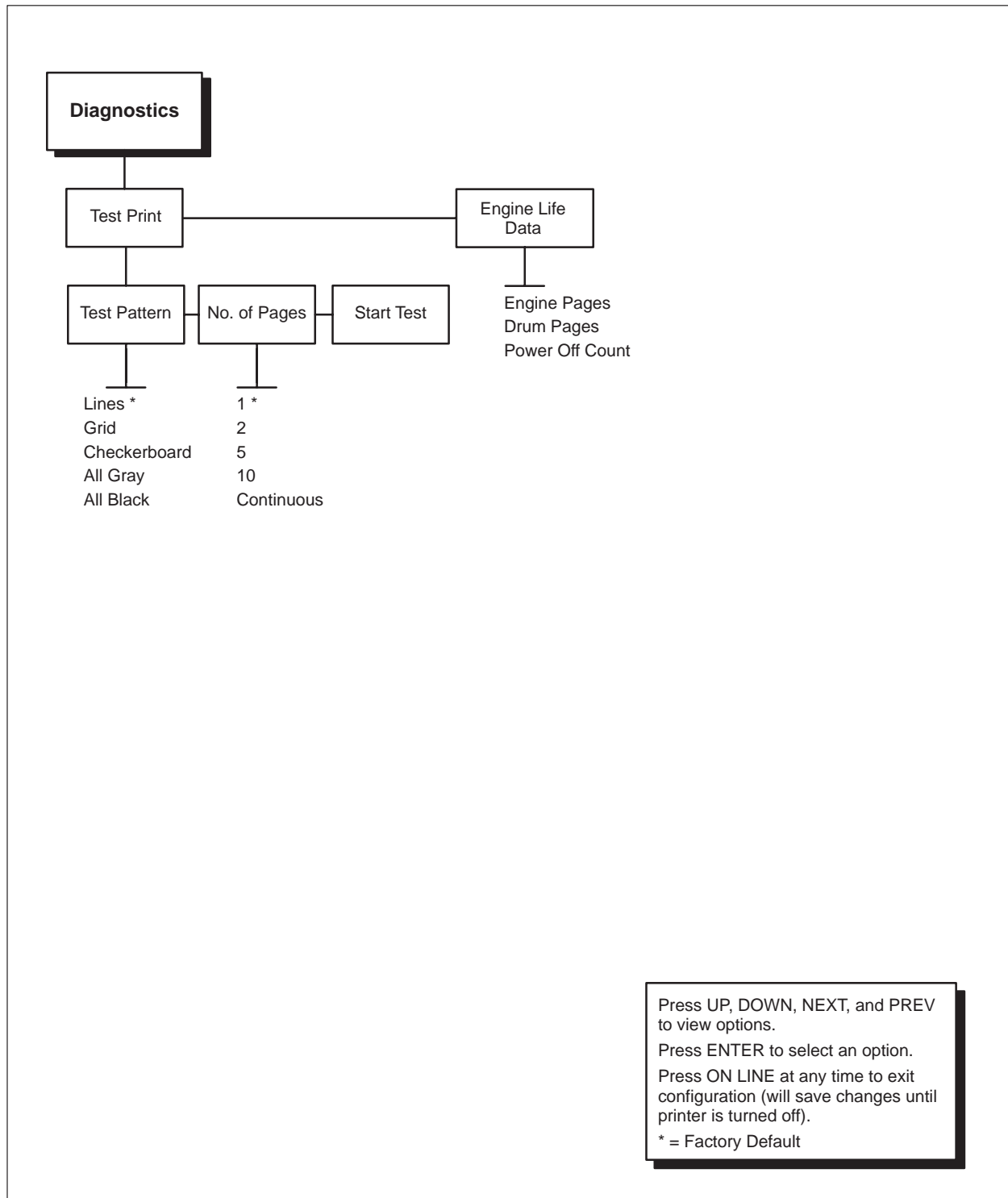

Figure 3-4. Printer Control Menu

Test Print

The test print option allows you to print different user specified test patterns for a user specified number of pages. The test print can be used to identify the source of printer image problems.

The factory default for the test pattern is lines and the default for number of pages is 1. The selections for these options are:

Test Pattern

- Lines *
- Grid
- Checkerboard
- All Gray
- All Black

Number of Pages

- 1*
- 2
- 5
- 10
- Continuous

Press Enter

Engine Life Data

Engine life data provides you with information concerning page count and power off count. This data is used by the controller to determine the proper time to replace consumables. The power off count is used to identify the proper time to replace the EPROM. The specific information provided on the control panel is:

Engine Pages

Drum Pages

Power Off Count

Disk Management Menu

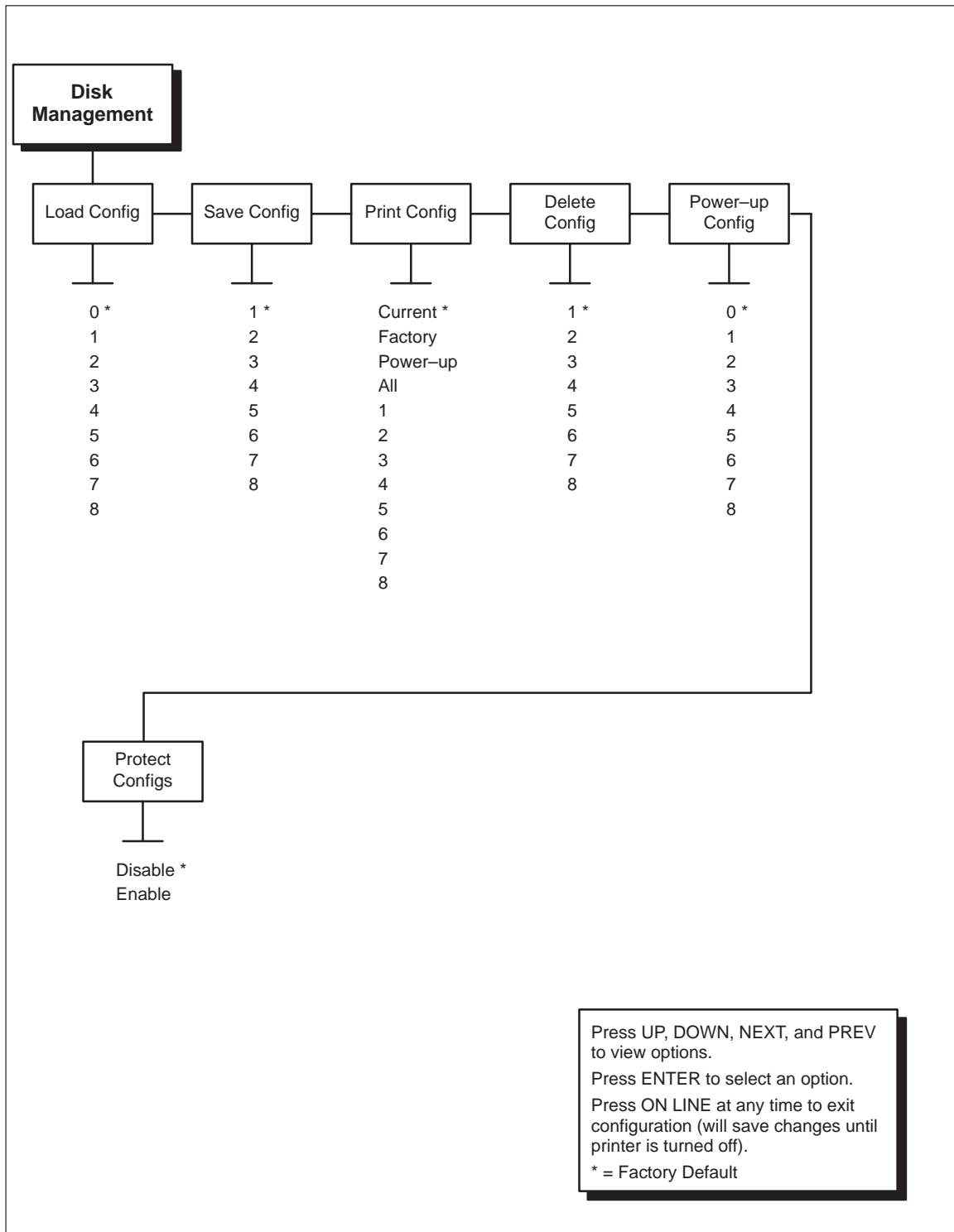

Figure 3-5. Disk Management Menu

Load Configuration

The printer can store numerous configurations. This option allows you to select and load a specific configuration.

The factory default for loading is configuration 0. Note that configuration 0 is a factory–preset configuration that cannot be changed and is always available for loading.

Save Configuration

This option allows you to save up to eight different configurations to meet different print job requirements. See page 3–7.

Configuration 0 is a factory–preset configuration that cannot be changed or saved.

NOTE: If the “Protect Configs.” option is enabled, the new configuration will not be saved unless the existing configuration has been deleted. Refer to page 3–25 for details.

Print Configuration

This option is used to output a listing of various stored printer configuration parameters. You can print the following configurations:

- Current
- Factory
- Power–up
- All
- 1–8 customized configurations

For details, refer to page 3–13.

Delete Configuration

This option allows you to delete a configuration file. You can delete one or all of your eight customized configurations.

Configuration 0 is a factory–preset configuration and cannot be changed or deleted.

Power–up Configuration

This option allows you to specify one of nine (0–8) configurations to be used upon printer power–up. The factory default for power–up is configuration 0.

Protect Configurations

This option allows you to specify whether or not a new configuration should “overwrite” an existing configuration when you activate the “Save Config” option.

When disabled (default), the new configuration will overwrite the existing configuration. When enabled, the new configuration will *not* overwrite the existing configuration, and the following will be displayed:

CFG FILE EXISTS
DELETE FIRST

Therefore, with the option enabled, you must delete an existing configuration before trying to save a new configuration.

Mode Emulation Menu

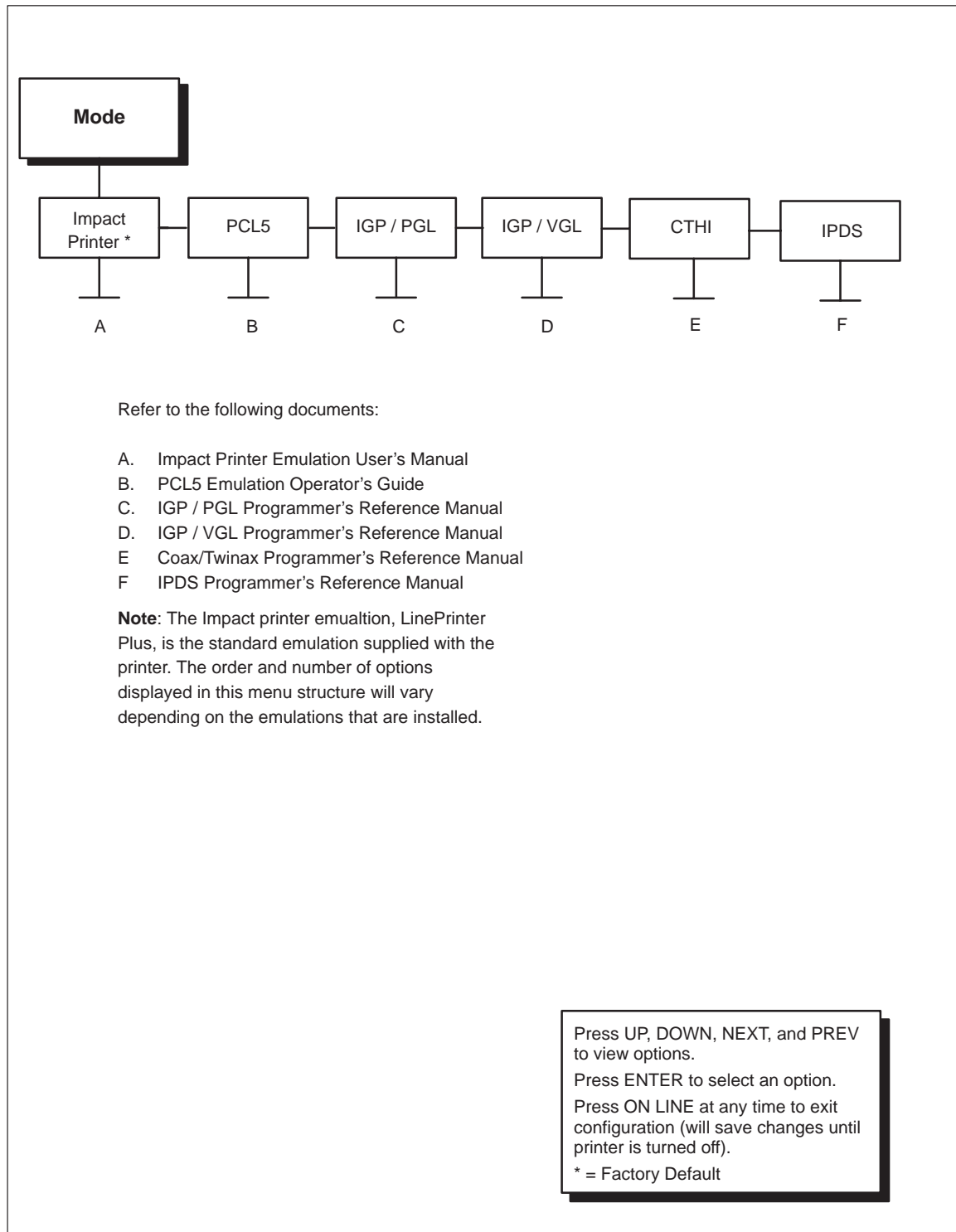

Figure 3–6. Mode Menu

In most cases, Mode refers to the emulation that you will use. The Printronix LinePrinter Plus emulation is the standard emulation mode. IGP/PGL, IGP/VGL, CTHI, IPDS, or PCL5 Language Compatible emulations are available as options.

The contents of the Mode menu structure will be created by the printer at run-time when the printer software reads the diskette to determine what interpreter(s) is available.

When powered-up, the printer will automatically load the default configuration values. The default set of parameters is the factory setting until a new setting is saved to default. Refer to the “Factory Settings” section on page 3–14 to restore the factory settings after you have created a new default setting.

NOTE: Each emulation may have its own set of configuration options in addition to those that are in the printer system list. Refer to the appropriate Programmer’s Reference Manual or Operator’s Guide for these unique configuration settings.

Impact Printer Emulation

The printer comes equipped with the Printronix LinePrinter Plus Emulation software. Refer to the *Impact Printer Emulation User’s Manual* for details, including configuration parameter definitions.

PCL5

The Printronix PCL 5 emulation is a software application that emulates the features and functionality of Hewlett-Packard’s PCL 5 printer language. Refer to the *Phoenix Page PCL5 Emulation Operator’s Guide* for details, including configuration parameter definitions.

IGP/PGL

IGP/PGL is the Intelligent Graphics Printing software for the Printronix Graphics Language, which is designed for the new Printronix PSA line of impact and non-impact printers. The IGP/PGL provides on-line forms, bar codes, and many alphanumeric text-generation capabilities and is compatible with earlier versions of Printronix IGP protocol and programming. Refer to the *IGP/PGL Printronix Graphics Language User’s Manual* for details, including configuration parameter definitions.

IGP/VGL

The IGP/VGL is the QMS[®]-compatible Intelligent Graphics Printing software designed for the new line of Printronix open-architecture impact and non-impact printers. IGP/VGL emulates the QMS Code V[™] Version II programming language to produce on-line forms, bar codes, and many alphanumeric text-generation capabilities. Refer to the *IGP/VGL Code V[™] Graphics Language User's Manual* for details, including configuration parameter definitions.

CTHI

CTHI stands for Coax/Twinax Host Interface. Coax and Twinax are different types of wires used to connect computers to input or output devices. The Coax/Twinax setting is able to mimic various printer models that use coax or twinax wiring. Refer to the *Coax/Twinax Programmer's Reference Manual* for more details.

IPDS

IPDS stands for "Intelligent Printer Data Stream." It is used to control advanced function printers. It is an "architected" printer-hardware data stream and describes how printers (hardware) and printer drivers (software) can work together. Refer to the *IPDS Programmer's Reference Manual* for more details.

Maintenance/Miscellaneous Menu

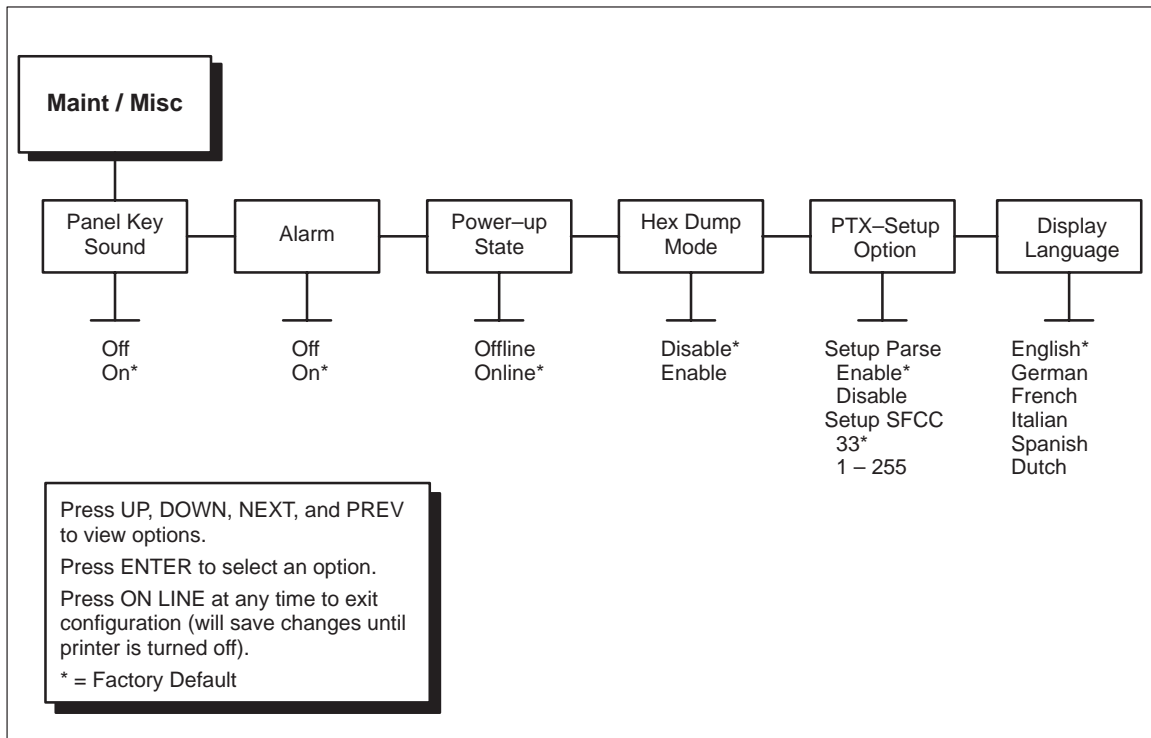

Figure 3-7. Maintenance/Miscellaneous Menu

Panel Key Sound

This option allows you to configure the printer to beep when you press a key (switch).

Alarm

This option allows you to configure the printer to beep when a printer fault condition occurs.

Power-up State

This option allows you to configure the printer to power-up in the offline or online state.

Hex Dump Mode

This option allows you to place the printer into the “hex dump” mode, in which the printer will output a hexadecimal data stream.

When enabled, the hex dump mode translates all host interface data to its hexadecimal equivalent, then prints the hex code and its printable symbol, if one exists. Figure 3–8 shows a partial example of a hex dump.

All characters printed after entering the hex dump mode (including any in the input buffer) are printed in two forms: as a two–symbol hexadecimal code and as its printable symbol, if any. A non–printable code is printed as a period [.] symbol. Up to 16 characters can be printed per line. No control codes will be acted upon by the printer while in hex dump mode.

The 16 characters are formatted so that the 16 printable symbols are printed in columns 1 through 16. The 17th column is blank. Column 18 contains either a p (PI line active) or a blank (PI not active). Columns 19 and 20 contain the hexadecimal code for the first character, followed by a blank. The PI line condition and hexadecimal code for the second character is printed in columns 22, 23, and 24, followed by a blank. The hexadecimal code for the 16th character is printed in columns 78, 79, and 80.

Subsequent printing observes the current setting for skip–over perforation, form length, and top–of–form position parameters.

Cancel the hex dump mode (while off–line), by disabling it from the control panel. The paper then may be advanced to the next top–of–form.

If a fault occurs while printing a hex dump, the printer reverts to the normal fault state. When the fault is cleared, the printer resumes printing the hex dump (either a partial line with a form feed, or nothing at all). Top–of–form remains unaffected.

NOTE: Hex dump mode may not be selected when the Twinax or Coax interface is selected. Refer to the Coax/Twinax or IPDS manual to see how to get a Coax or Twinax buffer dump.

The Impact Print	54	68	65	20	49	6D	70	61	63	74	20	50	72	69	6E	74
er Emulation pri	65	72	20	45	6D	75	6C	61	74	69	6F	6E	20	70	72	69
nts in one-up, t	6E	74	73	20	69	6E	20	6F	6E	65	2D	75	70	2C	20	74
wo-up, and four-	77	6F	2D	75	70	2C	20	61	6E	64	20	66	6F	75	72	2D
up page windows,	75	70	20	70	61	67	65	20	77	69	6E	64	6F	77	73	2C

Figure 3–8. Example of Hex Dump

PTX–Setup Option

The option provides the ability to enable or disable the setup parse and to select the special function control code (SFCC).

Setup Parse controls the use of PTX setup commands from the host computer. With the option enabled, PTX setup commands are used. With the option disabled, PTX setup commands are not used.

Setup SFCC allows you to choose the special function control code to be used with your application. Any single hexadecimal control code between 01 and FF can be selected.

NOTE: This feature is not available with the PCL–V emulation.

Display Language

This option is used to select the language for the control panel display. This selection will change the display of all information on the LCD. The selections are:

- English*
- German
- French
- Italian
- Spanish
- Dutch

NOTE: This feature is not available with the PCL–V emulation.

Host Interface Menu

The printer provides the following host I/O interface selections:

- Centronics parallel
- Dataproducts parallel (requires optional cable adapter, p/n 703316-001)
- Serial (RS-232 or RS-422)
- Twinax (optional)
- Coax (optional)

NOTE: When the Twinax IPDS emulation is installed, the host Interface menu will not be available. Instead, the Twinax interface will be automatically selected, and the interface parameters may be changed in the MODE-CTHI menu. See the *IPDS Programmer's Manual* for details.

NOTE: The RS-422 option can be enabled or disabled via a menu option on the control panel under the host interface selection. Make sure this selection is properly made for your application.

NOTE: The Coax interface is not currently selectable.

The configuration options for each interface type are shown in the illustrations on the following pages. Descriptions of the options follow each illustration. Set these options to meet the specific data communication requirements of the host and the application running on the host.

NOTE: For interface connector pin assignments and additional host interface signal information, refer to Appendix B.

Centronics Interface Parameters

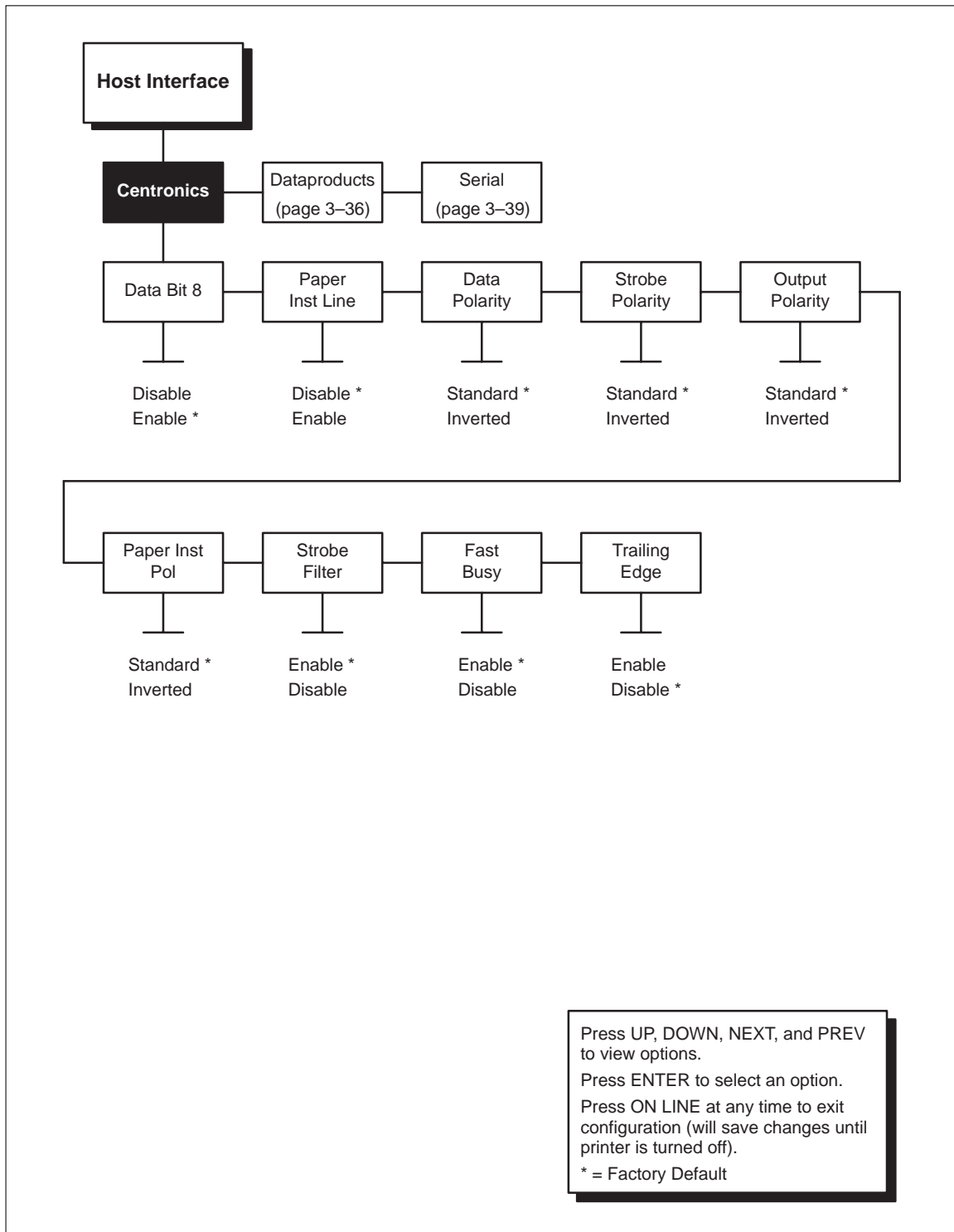

Figure 3-9. Centronics Interface Menu

Data Bit 8

Values: Enable or Disable.

Normally, this parameter is enabled. It allows access to the extended ASCII character set.

Paper Instruction (PI) Line

Values: Enable or Disable.

Paper Instruction Line is used to enable or disable paper motion. It is dependent on your host computer.

Data Polarity

Values: Standard or Inverted.

It must be set to match the Data Polarity of your host computer.

There are normally seven or eight data bits that define each ASCII character sent from the host computer to the printer. The bits are usually high-true.

Strobe Polarity

Values: Standard or Inverted.

It must be set to match the Data Strobe Polarity of your host computer.

When the host computer sends a data strobe signal, it is indicating that it has placed data on the data bus and that the data is valid (i.e., enough time has elapsed for the data lines to stabilize). The data strobe signal forces the printer to read the data lines into its input buffer.

Output Polarity

Values: Standard or Inverted.

It must be set to match the Output Polarity of your host computer.

This option inverts the normal sense of the NACK, BUSY, SELECT, PAPER EMPTY, and NFAULT output control signals

Paper Instruction Pol

Values: Standard or Inverted.
It must be set to match the host computer.

PI Line is used to enable or disable paper motion.

Strobe Filter

Values: Enable or Disable.
It must be set to match the host computer.

When set to the short filtering mode, this filter will reject all NSTROBE pulses of less than 63 ns. When set to the default long filtering mode, all strobes of less than 313 ns will be rejected.

Fast Busy

Values: Enable or Disable.
It must be set to match the host computer.

In fast busy mode (default), busy will be driven high when the data has been successfully clocked into the printer. In slow busy mode, busy will be asserted only if needed to delay the interface for some reason. In this mode, the host must wait for the NACK pulse before sending the next word of data. The use of slow busy mode is not recommended.

Trailing Edge

Values: Enable or Disable.
It must be set to match the host computer.

Normally, data is sampled from the data lines [8–1] on the falling edge of the filtered NSTROBE signal. This option allows the data to be sampled on the rising, or trailing, edge.

Dataproducts Interface Parameters

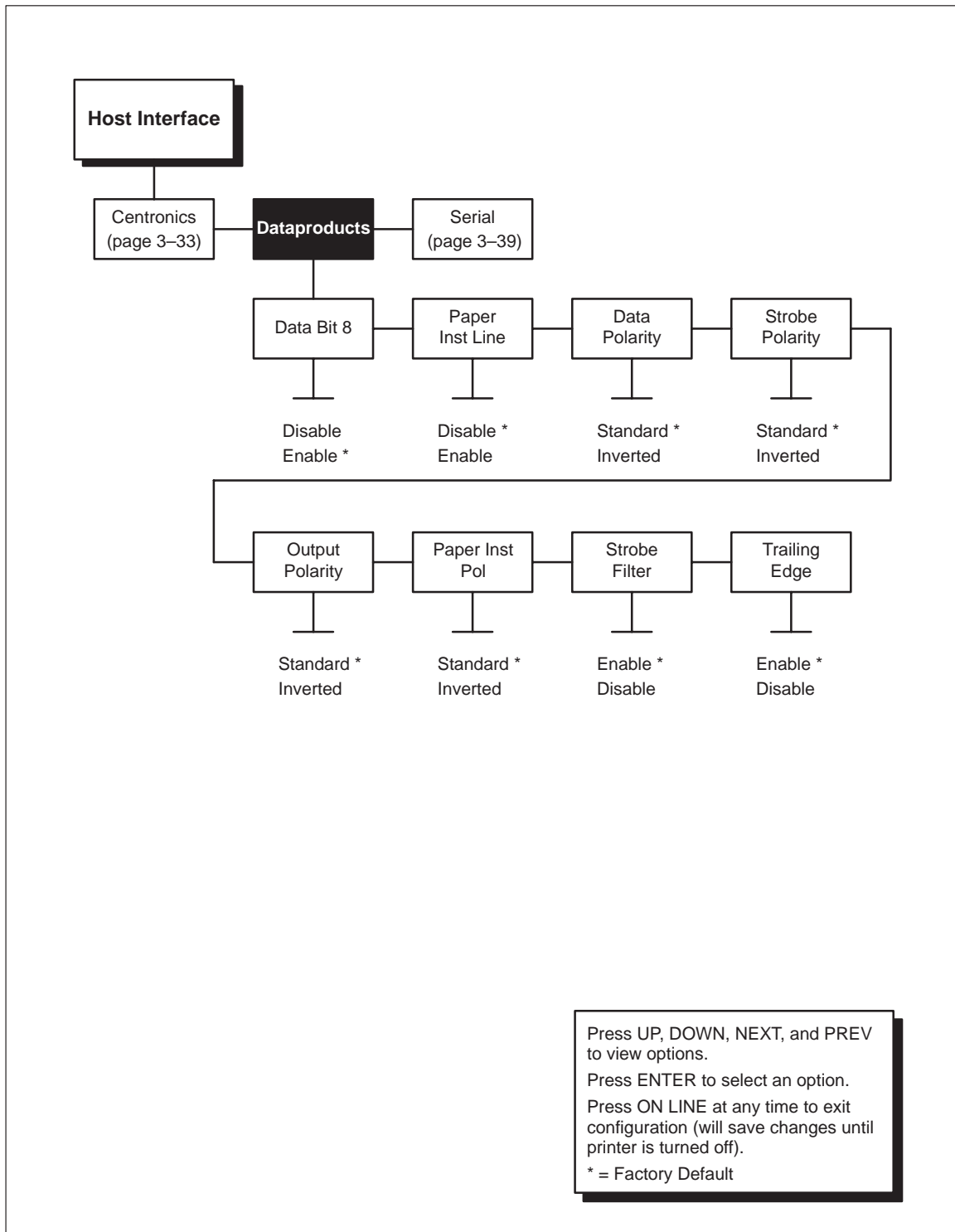

Figure 3-10. Dataproducts Interface Menu

Data Bit 8

Values: Enable or Disable.

Normally, this parameter is enabled. It allows access to the extended ASCII character set.

Paper Instruction (PI) Line

Values: Enable or Disable.

Paper Instruction Line is used to enable or disable paper motion. It is dependent on your host computer.

Data Polarity

Values: Standard or Inverted.

It must be set to match the Data Polarity of your host computer.

There are normally seven or eight data bits that define each ASCII character sent from the host computer to the printer. The bits are usually high-true.

Strobe Polarity

Values: Standard or Inverted.

It must be set to match the Data Strobe Polarity of your host computer.

When the host computer sends a data strobe signal, it is indicating that it has placed data on the data bus and that the data is valid (i.e., enough time has elapsed for the data lines to stabilize). The data strobe signal forces the printer to read the data lines into its input buffer.

Output Polarity

Values: Standard or Inverted.

It must be set to match the Output Polarity of your host computer.

This option inverts the normal sense of the NACK, BUSY, SELECT, PAPER EMPTY, and NFAULT output control signals.

Paper Instruction Pol

Values: Standard or Inverted. Must be set to match the host computer.

PI Line is used to signify that the eight data signals represent a special paper motion command, not printable data.

Strobe Filter

Values: Enable or Disable.
It must be set to match the host computer.

When set to the short filtering mode, this filter will reject all NSTROBE pulses of less than 63 ns. When set to the default long filtering mode, all strobes of less than 313 ns will be rejected.

Trailing Edge

Values: Enable or Disable.
It must be set to match the host computer.

Normally, data is sampled from the data lines [8–1] on the falling edge of the filtered NSTROBE signal. This option allows the data to be sampled on the rising, or trailing, edge.

Serial Interface Parameters (RS-232 and RS-422)

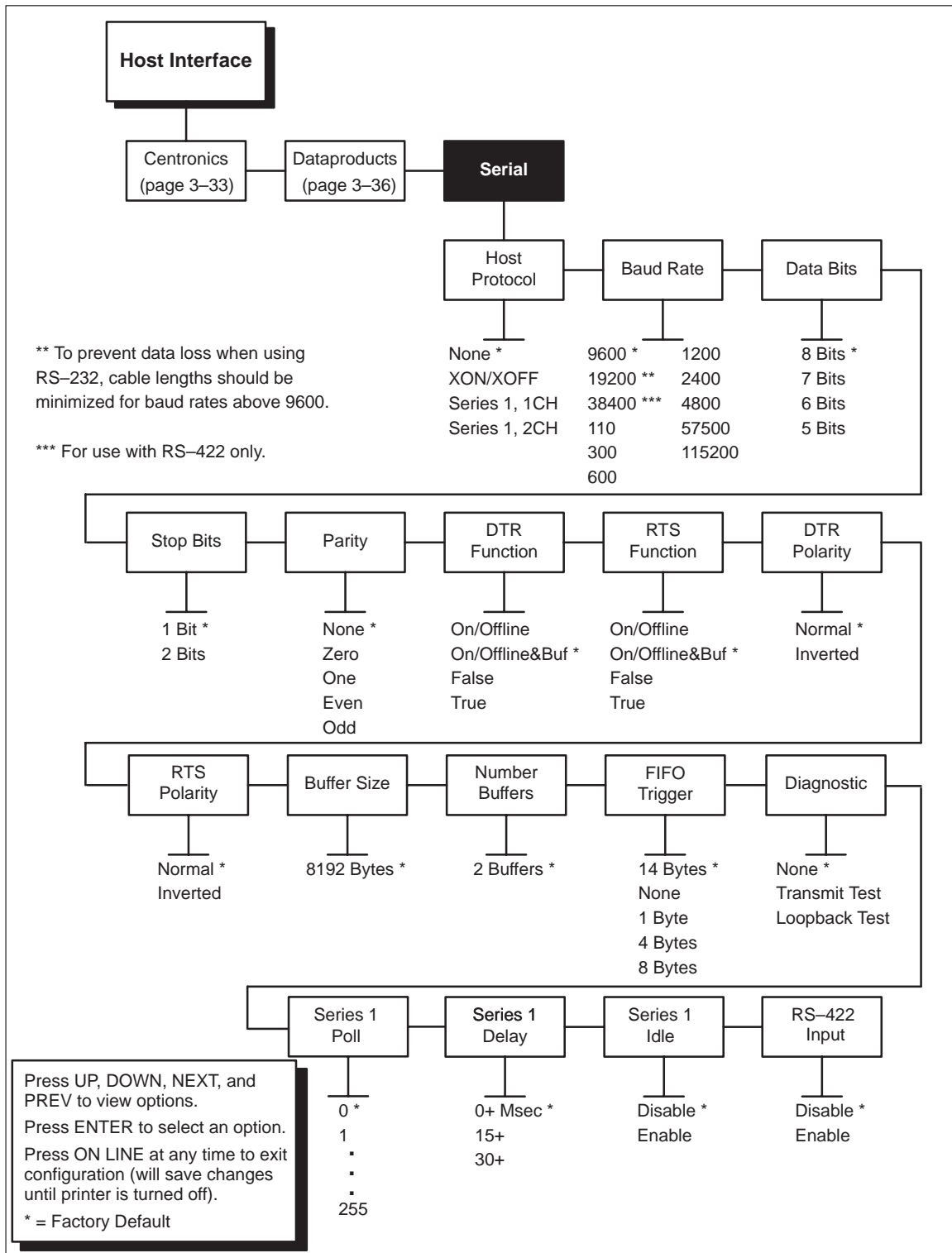

Figure 3-11. Serial Interface Menu

Host Protocol

Values: None; XON/XOFF; Series 1, 1 CH; Series 1, 2 CH.

It must be set to match your host computer.

XON means transmit on and XOFF means transmit off. In XON/XOFF protocol, the printer sends ASCII code DC1 (Device Code 1, hex 11, XON) to the host when it is ready to receive more data (i.e., the printer is online and the data buffer is empty). The printer sends ASCII code DC3 (Device Code 3, hex 13, XOFF) when it is not ready to receive data (i.e., the buffer is full or the printer is offline).

Series 1 protocol is a special protocol that sends a printer status code to the host computer whenever the status changes. The status code is either one or two characters with four status states defined.

The host computer can send a special “poll character” to the printer at anytime to request the current status.

An approximate delay can be selected to determine when the status is sent back to the host computer.

Baud Rate

Values: 110 – 115,200.

9600 is the default.

It must be set to match your host computer.

Baud rate is the number of bits, including control bits (start/stop and parity bits) transferred per second over the interface.

Data Bits

Values: 5 – 8.

It must be set to match your host computer.

Serial interfaces support 5, 6, 7, and 8-bit transfer of data words. Most use 8-bit data transfer, but this must match the host computer.

Stop Bits

Values: 1 or 2.

It must be set to match your host computer.

Stop bits signal the end of a transferred data word.

Parity

Values: None, 0, 1, Even, or Odd.

It must be set to match your host computer.

The host may send a parity bit with every data word. The parity bit is used for error checking.

DTR Function

Values: On/Offline&Buf, True, False or On/Offline.

It must be set to match your host computer.

Data Terminal Ready (DTR) is a status signal that is sent by the printer to the host to indicate whether the printer is ready to receive data. DTR can be set permanently true or false—true only if ready to receive (online and buffer is not full) or true only if not ready to receive (offline or buffer full).

RTS Function

Values: On/Offline&Buf, True, False or On/Offline.

It must be set to match your host computer.

The printer sends a Ready to Send (RTS) status signal to the host to request data transfer.

DTR Polarity

Values: Normal or Inverted.

This parameter allows the DTR signal to be inverted if required for a particular installation.

RTS Polarity

Values: Normal or Inverted.

This parameter allows the RTS signal to be inverted if required for a particular installation.

Buffer Size

Values: 8192 bytes.

This parameter reflects the size in characters of the printer's data buffer.

Number of Buffers

Values: 2.

This parameter reflects the number of data buffers in the printer's memory.

FIFO Trigger

Values: None, 1, 4, 8, or 14.

You can specify how many bytes the input First In, First Out (FIFO) buffer will store before the bytes are sent to the printer's data buffer.

Diagnostic

Values: None, Transmit, or Loop-back.

Used to test the serial interface circuits. Tests include a data transmission test and a serial loop-back test (which requires a loop-back plug).

Series 1 Poll

Values: 0, 1, 2, ... 255.

Specifies the poll character to be used by the host computer to request printer status using series 1 protocol.

Series 1 Delay

Values: 0+ msec, 15+ msec, 30+ msec

Specifies the delay between receiving the poll character and sending back the series 1 status. This delay is only approximate.

Series 1 Idle

Values: Enable or Disable.

When enabled, the printer will send the status approximately every 2 seconds. This status is sent if no data is being received and the buffer is empty.

RS-422 Input

Values: Enable or Disable.

Used to enable or disable the RS-422 serial input.

Font Memory Menu

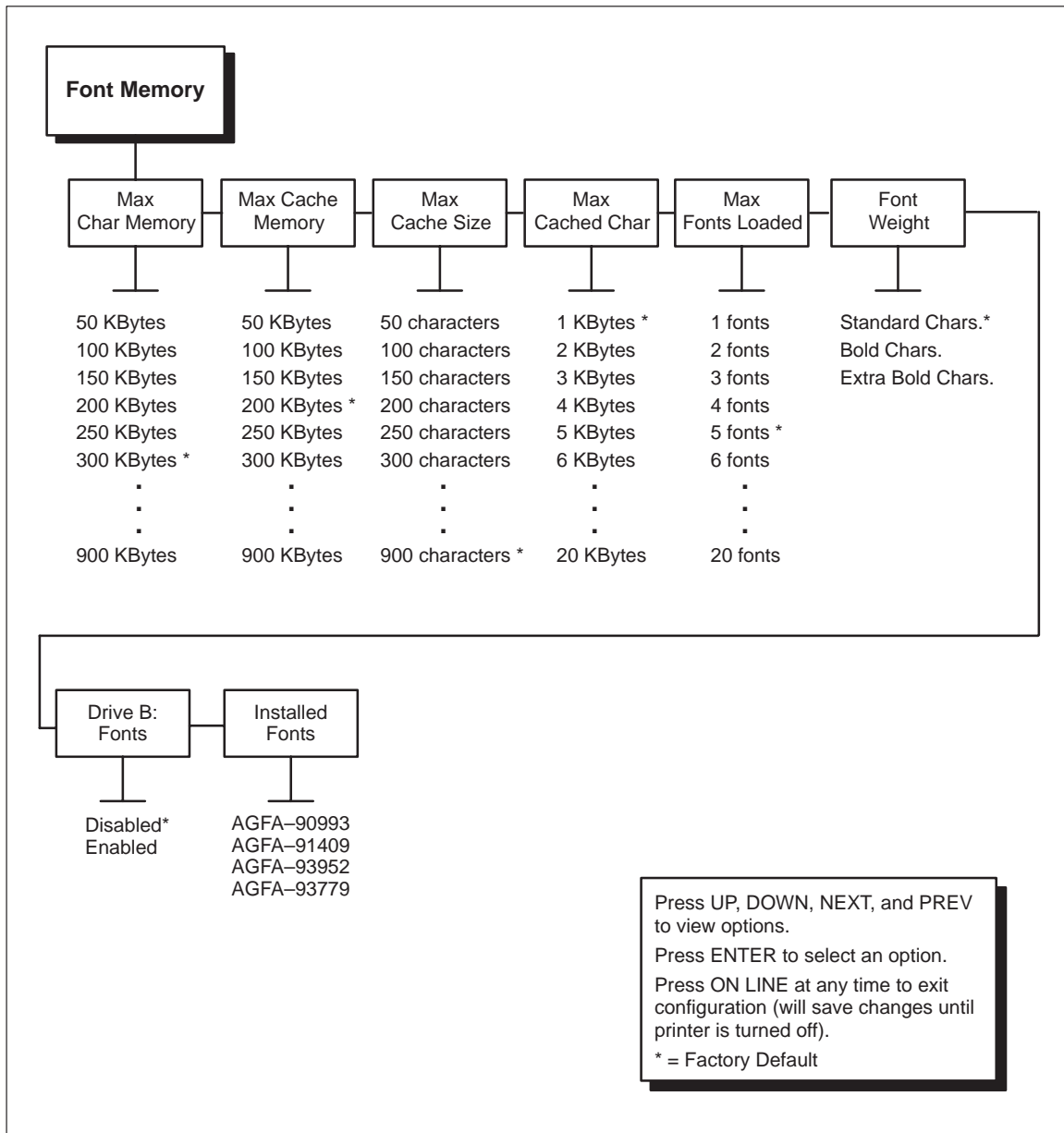

Figure 3-12. Font Memory Menu

NOTE: The configuration selections for the font memory are read at power-up time. To change options, make the changes, save the configuration, select the configuration as your power-up configuration, and reboot the printer.

Maximum Character Memory

This option is used to specify the size of the largest character that can be printed. To calculate the memory requirement, use this equation:

$$\frac{\text{horizontal resolution} \times \text{vertical resolution} \times \text{character height (inches)} \times \text{character width (inches)}}{8}$$

For example, if an application requires a character that is 7 inches high by 4 inches wide, calculate the Maximum Character Memory value as follows:

$$\frac{300 \times 300 \times 7 \times 4}{8} = 315,000$$

Therefore, select a value that is equal to or greater than 315,000. The closest available value is 350 KBytes.

The allowable range is 50 KBytes to 900 KBytes, in 50-KByte increments. The default value for this parameter is 300 KBytes.

Maximum Cache Memory

This option is used to specify the maximum block of memory that can be allocated to the font cache. The font cache stores bitmaps that are created on demand from the font outlines stored on the printer diskette. The cache allows the printer to print scalable fonts at optimum speed.

To calculate the memory requirement, use this equation:

$$\frac{\text{horizontal resolution} \times \text{vertical resolution} \times \text{average character height (inches)} \times \text{average character width (inches)} \times \text{\# of characters to be cached}}{8}$$

The allowable range is 50 KBytes to 900 KBytes, in 50-KByte increments. The default value for this parameter is 200 KBytes.

Maximum Cache Size

This option is used to specify the maximum number of characters that can be stored in the font cache.

The allowable range is 50 to 900 characters, in 50-character increments. The default value for this parameter is 900 characters.

Maximum Cached Characters

This option is used to specify the size of the largest character that can be stored in the font cache. To calculate the memory requirement, use this equation:

$$\frac{\text{horizontal resolution} \times \text{vertical resolution} \times \text{character height (inches)} \times \text{character width (inches)}}{8}$$

For example, if an application requires the use of a character that is 1 inch high by 1 inch wide, calculate the Maximum Cached Characters value as follows:

$$\frac{300 \times 300 \times 1 \times 1}{8} = 11,250$$

Therefore, select a value that is equal to or greater than 11,250. The closest available value is 12 KBytes.

The allowable range is 1 KBytes to 20 KBytes, in 1-KByte increments. The default value for this parameter is 1 KBytes.

Maximum Fonts Loaded

This option is used to specify the number of scalable font outlines that can be concurrently loaded into RAM in the printer.

The allowable range is 1 to 20 fonts, in 1-font increments. The default value for this parameter is 5 fonts.

Font Weight

This option specifies the weight of font to be used for printing.

The selections are standard characters, bold characters, and extra bold characters.
The default value for this parameter is standard characters.

Drive B: Fonts

Values: Disabled or Enabled.

This tells the system if fonts installed in Drive B: should be used. If disabled, your boot time will be shorter, but the printer will not use any fonts installed in disk drive B.

NOTE: For PCL-V and IPDS, the fonts installed in Drive B: will always be read.

Installed Fonts

This displays a list of fonts installed in the system. No selections may be made; this is for information purposes only.

NOTE: The bitmapped fonts in IPDS will not be displayed in this menu.

System Information Menu

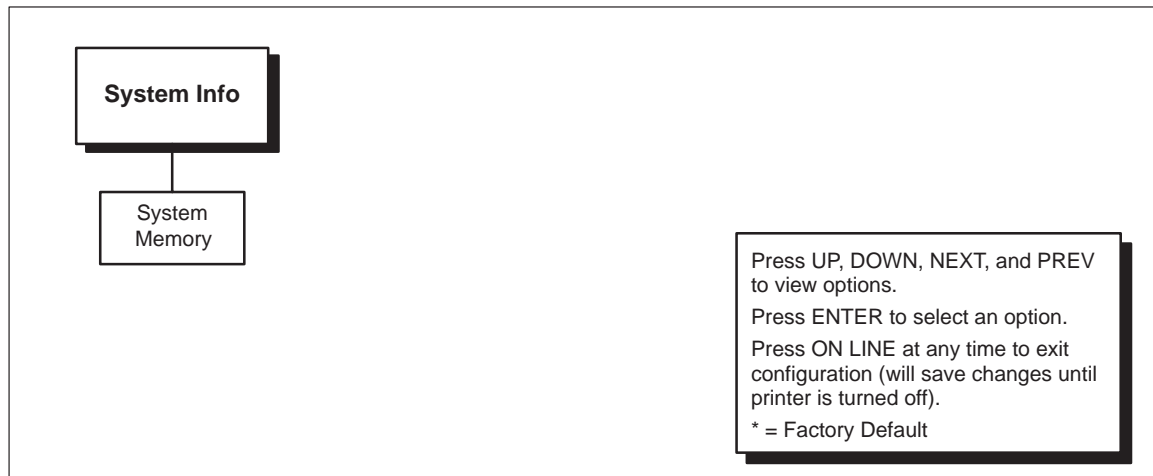

Figure 3–13. Font Memory Menu

System Memory

This menu item displays the amount of RAM that is available on the motherboard. There are 8 megabytes of RAM factory–installed on the motherboard.

Depending on the paper length selection, the following memory requirements must be met to allow the printer to run at optimum speed:

Paper Length	Memory	Fonts/Forms	Pages
3.0 to 14.0 inches (standard)	8 Megabytes	3 Megabytes	4 Megabytes
14.1 to 30.0 inches	12 Megabytes	3 Megabytes	8 Megabytes
30.1 to 33.00 inches	16 Megabytes	4 Megabytes	11 Megabytes

NOTE: Beyond 16 Megabytes of additional memory, all added memory is used for fonts/forms storage.

4 Diagnostics and Troubleshooting

Chapter Contents

Printer Diagnostics	4-2
Off-Line Diagnostics	4-2
On-Line Diagnostics	4-3
Running the Printer Test	4-3
Hex Dumps	4-4
Error Messages	4-5
Operator Calls	4-5
Fatal Error Messages	4-6

Printer Diagnostics

The printer includes self-diagnostic circuits and software to aid in the discovery, prevention, and correction of system problems and failures. Printer diagnostics fall into these categories:

- Off-line Diagnostics
- On-line Diagnostics

Off-Line Diagnostics

Most of the software diagnostics are executed under the following circumstances:

- The printer performs diagnostic routines when you request a configuration/test print via the control panel. The printout lists the current configuration of the printer. The test print also contains graphical content that demonstrates the quality of the image over the entire image area of the page.
- The printer performs a power-on self test each time the printer is powered on. During this test the printer will not produce a configuration/test print.

The power-on self test consists of the following:

- The printer controller self test:
 - ROM Checksum
 - Memory Test/Auto Configuration
 - CPU Interrupts and I/O

NOTE: Test failures for the printer controller are reported by a series of long and short beeps. Should your printer fail to power up, listen for the beep and report the pattern to your service provider; e.g. 3 long, 2 short, and 1 long beep.

- Control Panel Switches – Tests for switches that might be shorted.
- Print Engine FIFO – Checks for read/write errors.
- Engine Sensor Check – Scans engine status sensors including paper out, fuser temperature, toner level, cover/door interlocks, paper jam switches, waste toner container, and fuser cam motor.
- System Life Counts – Checks page count to verify that the OPC drum and the engine life counts have not been exceeded. The printer system counter, part of the OPC assembly, is reset when you replace the OPC.

On-Line Diagnostics

When on line, the printer continues to sense and report problems or conditions as they arise. Two categories of on-line error conditions exist: critical and non-critical.

The following critical errors stop the operation of the printer:

- Engine Sensor Checks – Scans engine status sensors including paper out, fuser temperature, toner level, cover interlocks, paper jam switches, and fuser cam motor
- Video Interface Error – Consists of interface protocol failures
- Optical System Errors – Includes beam detect, laser power, and mirror motor
- Toner Out
- Missing Components – Includes OPC drum unit and waste toner container

Non-critical errors allow the printer to continue to operate, but the LCD displays the conditions that exist. The following are non-critical errors:

- OPC Drum life exceeded
- EEPROM life exceeded
- Engine life exceeded

Running the Printer Test

This test checks both printer operation and the quality of printed output. If an unexpected error code is displayed, refer to “Error Messages” on page 4-5.

Following the procedure for the diagnostics menu test print, starting on page 3-22, will produce a test print of the desired pattern. The test pattern and number of pages can be selected from this menu.

Hex Dumps

The hex dump option, outlined in the *Operator's Guide*, allows you to place the printer in a mode in which the printer will output a hexadecimal data stream.

When enabled, the hex dump mode translates all host interface data to its hexadecimal equivalent, then prints the hex code and its printable symbol, if one exists. Figure 3–8 shows a partial example of a hex dump.

All characters printed after entering the hex dump mode (including any in the input buffer) are printed in two forms: as a two-symbol hexadecimal code and as its printable symbol, if any. A non-printable code is printed as a period [.] symbol. Up to 16 characters can be printed per line. No control codes will be acted upon by the printer while in hex dump mode.

The 16 characters are formatted so that the 16 printable symbols are printed in columns 1 through 16. The 17th column is blank. Column 18 contains either a p (PI line active) or a blank (PI not active). Columns 19 and 20 contain the hexadecimal code for the first character, followed by a blank. The PI line condition and hexadecimal code for the second character is printed in columns 22, 23, and 24, followed by a blank. The hexadecimal code for the 16th character is printed in columns 78, 79, and 80.

Subsequent printing observes the current setting for skip-over perforation, form length, and top-of-form position parameters.

Cancel the hex dump mode (while off-line), by disabling it from the control panel. The paper then may be advanced to the next top-of-form.

If a fault occurs while printing a hex dump, the printer reverts to the normal fault state. When the fault is cleared, the printer resumes printing the hex dump (either a partial line with a form feed, or nothing at all). Top-of-form remains unaffected.

NOTE: This is not available for Coax/Twinax. Use the buffer dump as described in the emulation manual instead.

The Impact Print	54	68	65	20	49	6D	70	61	63	74	20	50	72	69	6E	74
er Emulation pri	65	72	20	45	6D	75	6C	61	74	69	6F	6E	20	70	72	69
nts in one-up, t	6E	74	73	20	69	6E	20	6F	6E	65	2D	75	70	2C	20	74
wo-up, and four-	77	6F	2D	75	70	2C	20	61	6E	64	20	66	6F	75	72	2D
up page windows,	75	70	20	70	61	67	65	20	77	69	6E	64	6F	77	73	2C

Figure 4–1. Example of Hex Dump

Error Messages

Operator Calls

This section provides a description of error messages that indicate possible printer problems. Note that these errors are warnings only and “call the operator” for the identified corrective action. These errors do not cause the print job to be lost. Once the corrective action has been taken, the printing will resume.

Message	Problem	Corrective Action
01 CLOSE THE COVER	The printer cover is open.	Close the cover.
02 LOAD PAPER	Printer is out of paper.	Load paper. Refer to page 2–18.
03 ADD TONER AND CHK WASTE BOTTLE	Printer is out of toner.	Add toner and check waste toner bottle level. Refer to the <i>Operator's Guide</i> .
04 INSTALL TONER CUP	Toner waste bottle is not installed or not detected.	Install or reseal toner waste bottle.
05 INSTALL OPC DRUM	The OPC drum is not installed or not detected.	Install or reseal the OPC drum unit.
06 CLEAR PAPER JAM AT FUSER INPUT	Entry jam sensor is on.	Clear the paper jam. Refer to the <i>Operator's Guide</i> .
07 CLEAR JAM AT FUSER EXIT	Exit jam sensor is on.	Clear the paper jam. Refer to the <i>Operator's Guide</i> .
08 CLEAR JAM NEAR TOF LEVER	Jam occurred in paper path.	Clear the paper jam. Refer to the <i>Operator's Guide</i> .
09 CHECK TOF LEVER	Top of form sensor malfunction.	Inspect top of form sensor lever and call service if necessary.
19 PAPER CTL ERR Reload Paper	A paper motion error has been detected.	Burst paper at tractors and reload paper. Refer to page 2–18.
34 REPLACE OPC DRUM Call Service	The OPC drum unit has exceeded its life of 30,000 printed pages.	Replace the OPC drum unit.

Fatal Error Messages

This section provides a description of error conditions that cause printing to stop. These errors are provided for information only. The corrective action in all cases is to first perform the reset function described in the *Operator's Guide*. If the printer reset does not solve the problem, cycle the printer power. If a reset or power cycle does not solve the problem, call your authorized service representative.

Message	Problem
15 FUSER FAIL Call Service	A rotation error of the pressure roller cam has occurred. There is an unfused image at the fuser.
16 FUSER FAIL Call Service	Pressure roller cam did not stop or is out of position after stop attempt or the sensor is bad.
17 FUSER FAIL Call Service	Pressure roller cam did not start or the sensor is bad.
18 FUSER FAIL Call Service	The sensor that detects the position of the speed control plate is defective.
23 THERMISTR FAIL Call Service	Thermistor wire broken.
24 THERMISTR FAIL Call Service	Thermistor shorted due to extraordinarily high temperature.
25 ENCODER FAIL Call Service	Defective or dirty encoder needs to be replaced.
26 HEATER FAIL Call Service	Fuser did not warm up within specified time.
27 HEATER FAIL Call Service	Fuser temperature not maintained during printing.
28 BEAM DET FAIL Call Service	Beam detect failure. Motor spinning but not generating interrupts.
29 LSU FAIL Call Service	No "ready" returned from LSU phase lock circuit.
30 LSU FAIL Call Service	LSU phase lock lost.
31 LSU FAIL Call Service	"Ready" returned from LSU phase lock circuit but LSU motor not enabled.
32 MISPRINT ERROR Call Service	Failed handshaking between engine and CPU controller board.
33 REPLACE EEPROM Call Service	Engine controller EEPROM has exceeded its life expectancy of 100,000 writes.
35 EC CKSUM FAIL Call Service	A checksum error occurred while reading the EEPROM on the engine controller board.

A Specifications

Original Manufacturer Supplies

Consumables design, specification, and selection are critical and integral to the development of any computer printer imaging system.

For the name of your nearest full service distributor, please call:

United States	(800) 733–1900
Europe	(31) 2464–90111
Singapore	(65) 449–7555

The yield of the supplies is based on a 5% page coverage using 20 lb bond paper. In a typical business letter, for example, text covers about 5% of the page using 20 lb bond paper. However, applications that print more densely, such as graphics and bar codes, will use up the consumables at a faster rate.

In addition, the type of media used will determine the yield of the consumables. Optimum print quality and consumable life is obtained by using bond media rated between 18 and 20 pounds. Label stock and heavier media can also be used, but the print quality and consumable life, as well as the life of the fuser, may be reduced.

Toner Kit (704539–006):

Cleaner Felt (2 per kit)	8,000 pages (see note below)
Toner Bottle (2 per kit)	8,000 pages (at 5% page coverage)
Waste Toner Container	8,000 pages

NOTE: Normally, the fuser cleaner felt should be replaced every 8,000 pages. However, to ensure optimum print quality, you may want to replace it more often (e.g., every 6,000 pages). Call the number shown above to order additional cleaner felts. They are available in 10–packs only. The part number for the 10–pack is 704539–011.

OPC Drum Unit (704539–008) 30,000 pages
Fuser Felt – 10 pack (704539–011)

Developing Kit (704539–007):

Ozone Filter 100,000 pages
Developer Unit 100,000 pages
Starter Toner Bottle 200 pages
Cleaning Kit

Fuser Assembly (see note below):

120V (704539–012): 300,000 pages
230V (704539–013): 300,000 pages

NOTE: If all printer consumables have been replaced and image defects and/or paper creases persist, the fuser may need to be replaced. The fuser is the unit that heats the toner so that it adheres to the paper. Contact your authorized service representative for fuser replacement.

Printer Engine:

120V 3.0 million pages
230V 3.0 million pages

Controller

Built-in Motorola 68030 32-bit microprocessor with 8 MB RAM (expandable up to 40 MB), and 8 KB ROM. Any controller may be upgraded to 40 MB RAM with the addition of memory upgrade kits. Memory upgrade kits are available with any combination of one or two modules of 4 MB and/or 16 MB.

Electrical

Power Source	U.S. Domestic: 90 to 132 VAC/47 to 63 Hz European printers: 198 to 264 VAC/47 to 63 Hz
Type	Single Phase

Power Consumption

Operating Mode	1.5 kw (peak while fusing) 1.0 kw (average while fusing)
Standby Mode	0.3 kw (average for 80° F ambient)
Energy Saving Mode	Less than 45w
Recommended Cooling	4000 BTU/hr @ 100% printing

Dimensions

Height	9.8 in. (25 cm)
Width	18.2 in. (46 cm)
Depth	19.3 in. (49 cm)
Weight	58 lb. (26.3 Kg)

Environment

Temperature	+50° to + 90° F
Humidity	20% to 85% RH, noncondensing
Altitude	Up to 7,500 ft.
Acoustic Noise	Less than 53 dBA (operating)

Printing

Speed	Up to 24 pages per minute
Technology	Laser diode electrophotography
Initialization	3 minutes
Warm-up	30 seconds
Resolution	300 x 300 dpi

Interfaces

Standard	Centronics Parallel RS-232 and RS-422 Serial
Optional	Dataproducts (requires cable adapter) Coax Twinax LAN

Emulations

Standard	Line Printer Plus, HP PCL5 [®] , or Twinax IPDS
Optional	IGP/PGL IGP/VGL Line Printer Plus HP PCL5

Font and Character Sets

Printer emulation fonts and characters sets as well as custom fonts and scalable AGFA typefaces. The available fonts depend upon the emulation(s) installed.

Storage Media

Standard	Diskette drive: 3.5-inch, high density, double sided, 1.44 MB, DOS format
Optional	Diskette drive: 3.5-inch, high density, double sided, 1.44 MB, DOS format. Required for certain emulations. Refer to the emulation manual for details.

Options

Printer Memory	4 MB upgrade kit, p/n 704632-001 16 MB upgrade kit, p/n 704632-003 (Printer will accommodate 40 MB)
----------------	-----------------------------------------------------------------------------------------------------------

Paper Stacker (with printer stand)	Power stacker, p/n 704539-001 (120V) p/n 704539-004 (230V), capable of holding and stacking an entire box of print media
Emulations	IGP/PGL IGP/VGL Line Printer Plus HP PCL5 Twinax IPDS
Disk Drive	Diskette drive, p/n 704627-002, 3.5-inch, high density, double sided, 1.44 MB, DOS format
Interfaces	Dataproducts (requires cable adapter 703316-001) Coax Twinax Ethernet LAN

B

Host I/O Interfaces

The printer provides connections on the rear panel for the following host I/O interfaces:

- Centronics Parallel Interface
- Dataproducts Parallel Interface
- Serial Interface (RS-232 or RS-422)

All three interfaces are active simultaneously. The parameters for each interface are selected through the control panel via the “Host Interface” menu as described in Chapter 3, *Configuring the Printer*.

The location of the interface connectors is shown on 2-22 in Chapter 2, *Setting Up the Printer*.

You must supply the interface cable to connect the printer to your host computer. To facilitate the choice or manufacture of an interface cable for your application, pin assignments for the Centronics, Dataproducts, and serial interfaces are provided in this appendix.

Centronics Parallel Interface

This interface enables the printer to operate with controllers designed for buffered Centronics printers. The interface is capable of transferring up to 200,000 characters per second. The maximum cable length from the controller (host computer) to the printer is 15 feet.

Centronics Interface Connector Pin Assignments

The printer provides a 36-pin D-shell connector on the rear panel for connection of a Centronics parallel interface cable. Table B-1 lists the pin assignments of the Centronics interface connector.

Table B-1. Centronics Parallel Interface Connector Pin Assignments

Input Signals		Output Signals	
Signal	Pin	Signal	Pin
DATA LINE 1	2	ACKNOWLEDGE	10
Return	20	Return	28
DATA LINE 2	3	SELECT	32, 13
Return	21		
DATA LINE 3	4	PAPER EMPTY	12
Return	22		
DATA LINE 4	5	BUSY	11
Return	23	Return	29
DATA LINE 5	6		
Return	24		
DATA LINE 6	7		
Return	25		
DATA LINE 7	8		
Return	26		
DATA LINE 8	9		
Return	27		
PAPER INST	15	Chassis GND	17
Return	14		
DATA STROBE	1	Spares	18, 30, 31
Return	19		34, 35, 36

Centronics Parallel Interface Signals

The Centronics interface signals are defined below.

PAPER EMPTY – A high true level from the printer to indicate the printer is in a fault condition.

SELECT – A high true level from the printer to indicate the printer is ready for data transfer and the ON LINE switch has been activated.

BUSY – A high true level from the printer to indicate the printer cannot receive data.

ACKNOWLEDGE – A low true pulse from the printer indicating the character or function code has been received and the printer is ready for the next data transfer.

DATA STROBE – A low true, 100 ns minimum pulse from the host to clock data into the printer.

DATA LINES – Eight standard or inverted levels from the host that define the data, which may consist of a character or function code. Sensing Data Line 8 is controlled by printer configuration.

PAPER INST – Optional VFU control signal from the host with the same timing and polarity as the data lines. PI line sensing is controlled by printer configuration.

NOTE: The PAPER INST line must be disabled (configuration option selected from the front panel) if the host does not drive or control it. If the line is not controlled by the host and sensing is enabled, rapid paper slewing will occur.

Centronics Parallel Interface Configuration

The printer is configured for the Centronics interface via the “Host Interface” menu as described in Chapter 3, *Configuring the Printer*. The following interface configuration parameters may be modified to meet specific application requirements:

Data Bit 8	Enable* or Disable
Paper Instruction Line	Enable or Disable*
Data Polarity	Standard* or Inverted
Strobe Polarity	Standard* or Inverted
Output Polarity	Standard* or Inverted
Paper Instruction Polarity	Standard* or Inverted
Strobe Filter	Standard* or Inverted
Fast Busy	Standard* or Inverted
Trailing Edge	Standard* or Inverted

* = Factory default setting

Dataproducts Parallel Interface

This interface allows the printer to operate with controllers designed for Dataproducts printers. The interface is capable of transferring up to 500,000 characters per second. The maximum cable length from the controller (host computer) to the printer is 40 feet.

NOTE: Optional adapter cable (p/n 703316-001) and termination resistors RP1 330Ω (p/n 101381-331) and RP2 220Ω (p/n 101381-002) are required.

Dataproducts Interface Connector Pin Assignments

The printer provides a 36-pin D-shell connector on the rear panel for connection of a parallel interface cable. This 36-pin connector requires a cable adapter to convert it to a 50-pin AMP connector for Dataproducts compatibility. Contact the factory for the adapter (p/n 703316-001). Table B-2 lists the pin assignments of the Dataproducts cable adapter.

Table B-2. Dataproducts Parallel Interface Pin Assignments (Cable Adapter)

Input Signals		Output Signals	
Signal	Pin	Signal	Pin
DATA LINE 1	19	READY/FAULT	22
Return	3	Return	6
DATA LINE 2	20	ON LINE/SELECT	21
Return	4	Return	5
DATA LINE 3	1	DATA REQUEST/ACK	23
Return	2	Return	7
DATA LINE 5	34	Interface Verif.	45, 46
Return	18		
DATA LINE 6	43	PAPER INST	30
Return	42	Return	14
DATA LINE 7	36		
Return	35		
DATA LINE 8	28		
Return	44		
DATA STROBE	38		
Return	37		

NOTE: The printer comes standard with 470/1K ohm terminator resistors. Verify host computer port termination resistor requirements. In most cases, Dataproducts requires 220/330 ohm termination resistors. Optional termination resistors are available from your service provider.

Dataproducts Parallel Interface Signals

The Dataproducts interface signals are defined below.

READY – A high true signal from the printer indicating AC power and DC voltages are present, paper is loaded properly, and the printer is not in a fault condition.

ON LINE – A high true signal from the printer indicating the Ready Line is true and the ON LINE switch on the control panel has been activated. The printer is ready to accept data from the host.

DATA REQUEST – A high true signal from the printer to synchronize host data transmission with printer timing. This signal goes true when the printer is ready to receive data. It changes to the false state shortly after the leading edge of the data strobe signal.

DATA STROBE – A high true pulse from the host to indicate that data is ready. The data strobe must remain high at least until the Data Request line goes false.

DATA LINES – Eight standard or inverted levels from the host that specify character data, plot data, or a control code. Sensing Data Line 8 is controlled by printer configuration.

PAPER INST – Optional standard or inverted level VFU signal from the host with the same timing and polarity as the data lines. PI line sensing is controlled by printer configuration.

NOTE: The PAPER INST Line must be disabled (configuration option selected from the front panel) if the host computer does not drive or control the PI Line. If the line is not controlled by the host and sensing is enabled, rapid paper slewing will occur.

Interface Verification – Two pins on the interface connector jumpered together allow you to verify proper installation of the interface connector.

Dataproducts Parallel Interface Configuration

The printer is configured for the Dataproducts interface via the “Host Interface” menu as described in Chapter 3, *Configuring the Printer*. The following interface configuration parameters may be modified to meet specific application requirements:

Data Bit 8	Enable* or Disable
Paper Instruction Line	Enable or Disable*
Data Polarity	Standard* or Inverted
Strobe Polarity	Standard* or Inverted
Output Polarity	Standard* or Inverted
Paper Instruction Polarity	Standard* or Inverted
Strobe Filter	Enable or Disable*
Trailing Edge	Enable or Disable*

* = Factory default setting

Termination Resistors

For parallel interface configurations, the printer is equipped with 470/1K ohm pullup/pulldown terminating resistors located on the printer motherboard.

Generally, these terminating resistors are suitable for most applications. If, however, the standard terminating resistor pack is not compatible with the particular interface driver requirements of your host computer, other values or combinations of pullup/pulldown resistors may be necessary.

If you are experiencing communication problems between the printer and host; such as double characters, incorrect characters, or loss of data, the cause may be the value of the termination resistors on the motherboard. Contact your authorized service representative for instructions on replacing the termination resistors.

Table B-3. Dataproducts Parallel Interface Termination Resistors

Part Number	Description	Main Controller Location
101381-331	330Ω Pull Up Resistor	RP1
101381-002	220Ω Pull Down Resistor	RP2

RS-232 Serial Interface

This interface is used with bit serial devices compatible with EIA RS-232C or CCITT V.24 standards. The interface circuit characteristics are compatible with the Electronic Industry Association Specification.

The printer is configured as Data Terminal Equipment (DTE).

The serial data transfer baud rate is selectable from the control panel. The input format consists of a single start bit, 7 or 8 data bits, and one or two stop bits. The operator can set the number of data bits from the control panel. The data bits are interpreted with the least significant bit first. The operator can also set parity checking via the control panel. The printer interface uses a first-in/first-out buffer with the size selectable from the control panel. The asynchronous interface accepts data as it is provided by the host computer.

The maximum cable length from the host computer to the printer is 50 feet.

RS-232 Interface Connector Pin Assignments

The printer provides a 25-pin DB-25S connector on the rear panel for connection of a serial interface cable. Table B-4 lists the pin assignments of the RS-232 interface connector.

Table B-4. RS-232 Serial Interface Pin Assignments

Pin	Signal	Direction
1	Chassis Ground	Not applicable
2	Transmit Data (TxD)	From printer
3	Receive Data (RxD)	To printer
4	Request To Send (RTS)	From printer
5	Clear To Send (CTS)	To printer
6	Data Set Ready (DSR)	To printer
7	Signal Ground	Not applicable
8	Carrier Detect (CD)	To printer
11, 14	Reverse Channel (RC) (no connects)	From printer
20	Data Terminal Ready (DTR)	From printer

RS–232 Serial Interface Signals

The RS–232 serial interface signals are defined below.

Receive Data (RxD) – Serial data stream to the printer.

Transmit Data (TxD) – Serial data stream from the printer for transmitting status and control information to the host. Subject to protocol selection.

Request To Send (RTS) – Control signal from the printer. Subject to configuration.

Clear To Send (CTS) – Status signal to the printer indicating the host is ready to receive data/status signals from the printer. When CTS is enabled, DSR and CTS must both be asserted for the printer to transmit flow control characters to the host.

Data Set Ready (DSR) – Status signal to the printer indicating the host is in a ready condition. DSR is ignored unless CTS or CD are enabled.

Carrier Detect (CD) – Status signal to the printer. The ON condition is required for the printer to receive data. Available as a configuration setup option. When CD is enabled, the host must assert both DSR and CD for the printer to accept data.

Data Terminal Ready (DTR) – Control signal from the host to the printer. When enabled, the host will activate the data channel. Subject to configuration.

RS–232 Serial Interface Configuration

The printer is configured for the RS–232 serial interface via the “Host Interface” menu as described in Chapter 3, *Configuring the Printer*. The following interface configuration parameters may be modified to meet specific application requirements:

Host Protocol	None
Baud Rate	9600
Data Word Length	8 Data Bits
Stop Bits	1 Bits
Parity	None
Data Terminal Ready Function	On/Offline and Buffer
Request to Send Function	On/Offline and Buffer
Data Terminal Ready Polarity	Normal
Request To Send Polarity	Normal
Buffer Size	8192 Bytes
Number of Buffers	2
FIFO Trigger	14 Bytes
Diagnostics	None

NOTE: Only the factory default setting is shown above. Refer to the *Configuring the Printer* chapter for additional options.

RS-422 Serial Interface

This interface is used with bit serial devices compatible with EIA-RS-422A or CCITT V.27 and V.11 standards. The interface circuit characteristics are compatible with the Electronic Industry Association Specification.

The printer is configured as Data Terminal Equipment (DTE).

The serial data transfer baud rate is selectable from the control panel. The input format consists of a single start bit, 7 or 8 data bits, and one or two stop bits. The operator can set the number of data bits from the control panel. The data bits are interpreted with the least significant bit first. The operator can also set parity checking via the control panel. The printer interface uses a first-in/first-out buffer with the size selectable from the control panel. The asynchronous interface accepts data as it is provided by the host computer.

The maximum cable length from the host computer to the printer is 400 feet.

RS-422 Interface Connector Pin Assignments

The printer provides a 25-pin DB-25S connector on the rear panel for connection of a serial interface cable. Table B-5 lists the pin assignments of the RS-422 interface connector.

Table B-5. RS-422 Serial Interface Pin Assignments

Pin	Signal	Direction
1	Chassis Ground	Not applicable
25	Transmit Data + (TxD+)	From printer
19	Transmit Data - (TxD-)	From printer
17	Receive Data + (RxD+)	To printer
15	Receive Data - (RxD-)	To printer
7	Signal Ground	Not applicable

RS-422 Serial Interface Signals

The RS-422 serial interface signals are defined below.

Received Data (RxD) – Serial data stream from the host to the printer.

Transmitted Data (TxD) – Serial data stream from the printer to the host.
Subject to protocol selection.

RS-422 Serial Interface Configuration

The printer is configured for the RS-422 serial interface via the “Host Interface” menu as described in Chapter 3, *Configuring the Printer*. The following interface configuration parameters may be modified to meet specific application requirements:

Host Protocol	None
Baud Rate	9600
Data Word Length	8 Data Bits
Stop Bits	1 Bit
Parity	None
Data Terminal Ready Function	On/Offline and Buffer
Request to Send Function	On/Offline and Buffer
Data Terminal Ready Polarity	Normal
Request To Send Polarity	Normal
Buffer Size	8192 Bytes
Number of Buffers	2
FIFO Trigger	14 Bytes
Diagnostics	None

NOTE: Only the factory default setting is shown above. Refer to the *Configuring the Printer* chapter for additional options.

NOTE: The L1016 printer has an RS232/RS422 selector switch on the rear I/O panel. When the switch is in the RS232 or RS422 position, the L1016 connector is configured as shown in the appropriate column of the previous table.

Table B-6. RS422 Pin-out Comparison

Pin	L1016 RS232	L1016 RS422	L1024 RS232/RS422
1	Ground	Ground	Ground
2	TX (Output)	TX+ (Output +)	TX (Output)
3	RX (Input)	RX+ (Input+)	RX (Input)
4	RTS (Output)	RTS+ (Output +)	RTS (Output)
5	CTS (Input)	CTS+	CTS (Input)
6	DSR (Input)	DSR+	DSR (Input)
7	Ground	Ground	Ground
8			DCD (Input)
9			
10			
11			
12			
13		CTS- (Input-)	
14		TX- (Output-)	
15			RX- (Input-)
16		RX- (Input-)	
17			RX+ (Input+)
18			
19		RTS- (Output-)	TX- (Output-)
20	DTR (Output)	DTR+ (Output+)	DTR (Output)
21			
22		DSR- (Input-)	
23		DTR- (Output-)	
24			
25			TX+ (output+)

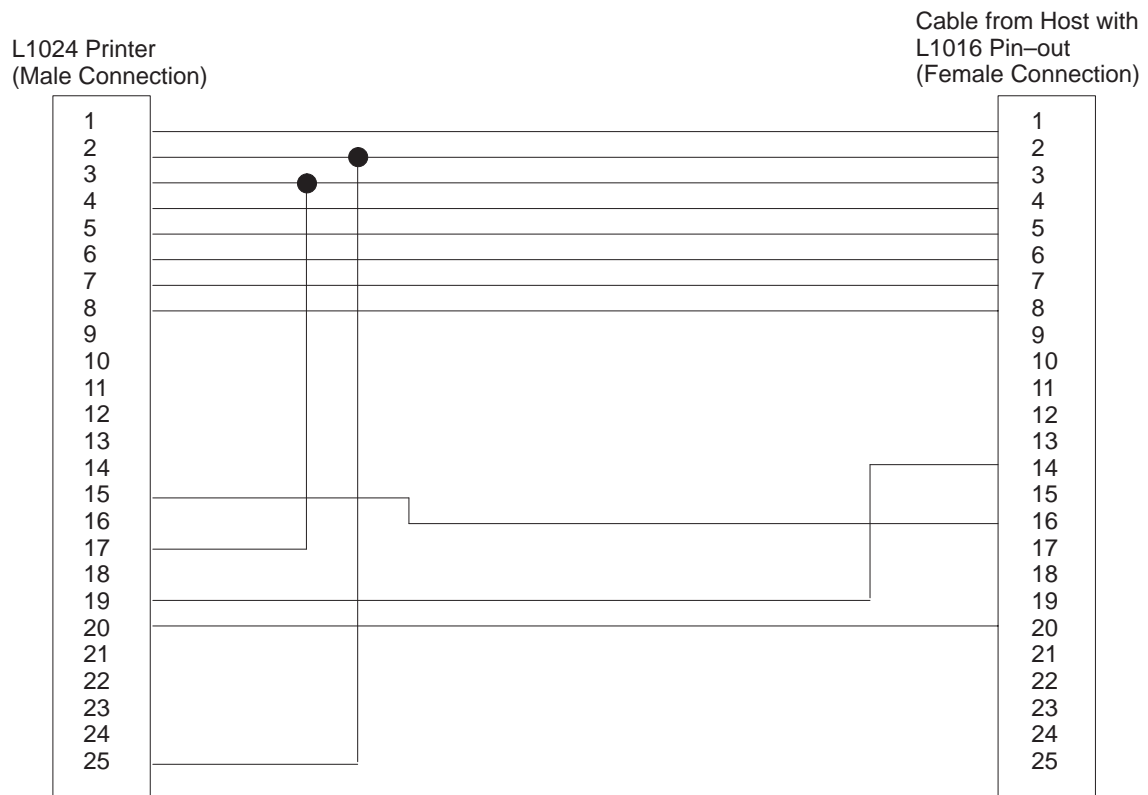

Figure B-1. RS422 Adaptor for Sites Previously Using L1016

Diagnostic Port

This interface is used for connection with a computer port to run diagnostic tests using software driven diagnostics. The connections, with a six pin RJ11 connector, are made as shown in Figure B-2 and Table B-7.

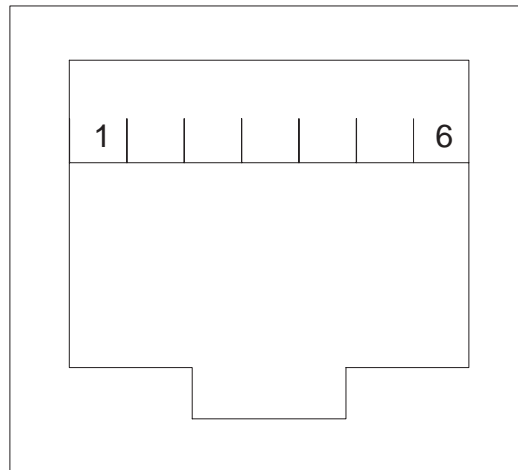

Figure B-2. Diagnostic Port

Table B-7. Diagnostic Port Interface Pin Assignments

Pin	Signal	Direction
1	No Connection	
2	RX	To Printer
3	GND	
4	TX	From Printer
5	Ground	
6	No Connection	

C

Media Requirements

The printer requires continuous form electrographic grade media with 0.5 inch pitch tractor feed pin holes. The media capabilities and requirements are listed below:

Width	4.0 to 10.0 inches edge to edge (3.5 to 9.5 inches pin to pin)
Length	3.0 to 33.0 inches in 1/8 or 1/6 inch increments
Weight	18 to 42 lb. bond (67 to 158 g/m ²) 110 lb. tag stock 99 lb. card stock
Labels:	
Face Stock	40 to 60 lb. book stock (60 to 90 g/m ²)
Carrier	50 lb. book stock (75 g/m ²)
Adhesive	acrylic
Cut to Tie (page perf)	≥ 2.9:1 (8 cuts/inch) bond (and microperf) ≥ 6.5:1 (4 cuts/inch) tag/card stock ≥ 6.5:1 (4 cuts/inch) label stock
Percent Recycled paper	20% maximum
Moisture Content	5% ± 1%
Resistivity	10 ⁸ to 10 ¹² ohms

NOTE: Bond paper weight based on 17 X 22 inch base size. Tag stock based on 24 X 36 in base size. Card stock based on 22 1/2 X 28 1/2 inch base size. Book carrier stock based on 25 X 38 inch base size.

D

Disk Space Savings

This appendix provides instructions for loading and using one, and only one, language for control panel messages. Procedures and examples are given for using a single language and deleting the unused languages from the disk. Deleting unused languages from the distribution disk will increase space for forms/font storage.

NOTE: Before conducting any of these procedures it is necessary to make a backup copy of the distribution disk. Use only the backup copy when performing these procedures.

English as the single language

English is the default language. If the single language to be used is English, it is a simple matter of deleting the language files that will not be used.

Place the backup copy of the distribution disk in the PC disk drive and delete the following language files:

spvr00.dut
spvr00.fre
spvr00.ger
spvr00.ita
spvr00.spa

Place the changed disk in the printer drive and apply power to the printer.

Other languages as the single language

For this example, the German language will be used as the single language. The procedure will be the same for the desired language.

Since German is not the default language on the distribution disk, a save configuration and a power-up configuration must be issued to make the German language the default language at power-up.

The following procedure will make the required configuration changes to make the remaining language the startup language. Refer to the *Configuring the Printer* chapter.

1. Change the language to German.
2. Refer to page 3–7 and save this configuration.
3. Refer to page 3–23 and select the current configuration as the power–up configuration.
4. Place the backup copy of the distribution disk in the PC disk drive and delete the following language files:

spvr00.dut
spvr00.fre
spvr00.ita
spvr00.spa
spvr00.usa

Place the changed disk in the printer drive and apply power to the printer.

Glossary

ACIA	<i>Acronym for Asynchronous Communication Interface Adapter.</i>
baud	A unit of speed that measures the rate at which information is transferred. Technically, baud rate is the reciprocal of the length in seconds of the shortest pulse used to carry data. For example, a system in which the shortest pulse is 1/1200 second operates at 1200 baud. On RS-232 serial lines, the baud rate equals the data flow rate in bits per second (bps). To communicate properly, a printer must be configured to operate at the same baud rate as its host computer.
bit	<i>Contraction of binary digit.</i> A digit in the binary (base 2) number system: 0 or 1. A bit is the smallest unit of storage in a digital computer, where 0 and 1 are represented by different voltages. Groups of bits forms other units of storage called <i>nibbles</i> , <i>bytes</i> , and <i>words</i> .
Boot-up	The start-up procedure which causes a computer operating system to be loaded into main memory.
buffer	A reserved area in memory. Data are written to and read from the buffer during data transfers.
charger	The charge corona applies a high negative charge to the surface of the photoconductor belt.
coax	Coaxial cable. A type of cable with a single wire surrounded by insulation and a braided shield.
configuration	The act of setting a bunch of electrical and data control options on a printer so that a computer and the printer can “talk” to each other. When properly configured, a printer can receive data from the computer, print the data, and send and receive control signals.
controller	An independent functional logic unit in a data processing system that controls data paths between one or more units of peripheral equipment.

data bits	Binary information sent to the printer; a character set grouping containing letters, digits, and punctuation marks to be printed.
default	A value, parameter, attribute, or option that is assigned by a program or system when another has not been specified by the user.
developer	The developer unit uses the toner and carrier particles to produce a developed image onto the surface of the photoconductor belt.
diagnostic	Pertaining to the detection and isolation of a printer malfunction or mistake.
diskette	A thin, flexible magnetic disk containing software such as test and diagnostic programs, initialization files, and all font specifications for the printer.
electrophotographic	A non–impact printing process in which electrical charges and heat are used to transfer and fuse images to paper, as opposed to impact printing, in which hammers or pins drive an inked ribbon onto paper to form characters.
emulation	Refers to the ability of a printer to execute the commands of another printer protocol.
fuser	The fuser unit uses heat and pressure to bond the toner to the surface of the paper.
host computer	The computer that stores, processes, and sends data to be printed, which communicates directly with the printer. The term “host” is used to indicate the controlling computer, since modern printers are themselves microprocessor–controlled computer systems.
interface	The hardware component used to link two devices by common physical interconnection, signal, and functional characteristics.
LSU	<i>Acronym for Laser Scanning Unit.</i> The beam of the laser scanning unit shines on a rotating polygonal mirror which causes the beam to scan across the OPC drum.

logical link	The parameters that specify data transfer, data control, and/or data communication operations.
macro	A macro is a collection of control codes, escape sequences, and data whose execution can be initiated by using a single command. This information is downloaded into the printer.
MPP	<i>Acronym for Maximum Print Position.</i> Also known as line length.
NMI	<i>Acronym for Non–Maskable Interrupt.</i>
non impact	Printing which does not result from any mechanical impact onto the paper. Example: an electrophotographic printer.
OPC	The material of the OPC drum is an insulator when in the dark and is conductive when exposed to light.
operating system	A collection of programs that control the overall operation of a computer system.
parity (check)	Parity checking is the addition of a non–data bit to data, resulting in the number of “1 bit” being either always even or always odd. Parity is used to detect transmission errors. Parity represents value in the check digit of the received or transmitted data.
PCB	<i>Acronym for Printed Circuit Board.</i> A PCB is an insulating board on which circuit paths have been printed or etched.
PCBA	<i>Acronym for Printed Circuit Board Assembly.</i>
port	A data channel used for receiving data from or transmitting data to one or more external devices.
protocol	The rules and conventions that govern communication between a printer and a host computer. A protocol includes codes for printing text and graphics and codes instructing the printer to perform special operations.
RAM	<i>Acronym for Random Access Memory.</i> Can be read from or written to at any time. RAM is volatile: Whatever is in RAM is lost when power is turned off.

read	To retrieve data from memory or mass storage (hard disk, floppy diskette, etc.).
resolution	A measure expressing the number of component units in a given range used to create an image; in printing, expressed as the number of dots per inch (dpi) horizontally and vertically.
ROM	<i>Acronym for Read Only Memory.</i> Programs, instructions, and routines permanently stored in the printer that cannot be written to. Files in ROM are not lost when power is turned off. (ROM–resident fonts are fonts permanently stored in a printer and available at any time via software commands.)
stop bits	The signal which indicates the end of a character or element.
toner	A fine, negatively–charged, black, powdery substance used to develop an image.
toner cartridge	Contains the toner (ink) that will be used to make marks on the paper.
transfer corona	The transfer corona causes the developed image to be attracted away from the photo–conductor belt and placed onto the surface of the paper.
twinax	Twinaxial. A type of cable with two wires surrounded by insulation and a braided shield.
write	To place data in memory (RAM, NVRAM) or in mass storage (hard disk, floppy diskette, etc.).

Index

A

About the Printer, 1–4

Alarm, 3–29

B

Baud Rate, 3–40

Buffer Size, 3–42

C

Cable Connections, 2–21

Centronics Interface, 3–33, B–2

Centronics Menu

data bit 8, 3–34

data polarity, 3–34

fault polarity, 3–35

output polarity, 3–34

paper instruction line, 3–34

paper instruction polarity, 3–35

strobe filter, 3–35

strobe polarity, 3–34

trailing edge, 3–35

Coax/Twinax, 3–28

Coax/Twinax Connection, 1–7

Configuration

changing parameters, 3–5

factory settings, 3–14

menus, 3–4, 3–16

modifying saved parameters, 3–10

printing parameters, 3–13

printout, 3–24

saving parameters, 3–7

Configuration Menus

diagnostics, 3–21

disk management, 3–23

font memory, 3–44

host interface, 3–32

maintenance/miscellaneous, 3–29

mode, 3–26

paper control, 3–17

printer control, 3–19

system information, 3–48

Configuring Parameters, 3–5

Control Panel, 3–4

Corrective Action

error messages, 4–5

fatal error messages, 4–6

operator calls, 4–5

D

Data Bit 8, 3–34, 3–37

Data Bits, 3–40

Data Polarity, 3–34, 3–37

Dataproducts Interface, 3–36, B–5

Dataproducts Menu

data bit 8, 3–37

data polarity, 3–37

data request polarity, 3–37

online polarity, 3–38

paper instruction line, 3–37

paper instruction polarity, 3–38

ready polarity, 3–38

strobe polarity, 3–37

Delete Configuration, 3–25

Developer Unit, 2–10

Diagnostic, 3–42

Diagnostic Port Interface, B-16

Diagnostics, 4-2, 4-3

 menu, 3-21

 off-line, 4-2

 on-line, 4-3

Disk Drive B, 1-7

Disk Management Menu, 3-23

 delete configuration, 3-25

 load configuration, 3-24

 power-up configuration, 3-25

 print configuration, 3-24

 protect configurations, 3-25

 save configuration, 3-24

Disk Space Savings, D-1

Display Language, 3-31

Distribution Disk, D-1

Drive B: Fonts, 3-47

Drum Pages, 3-22

DTR Function, 3-41

DTR Polarity, 3-41

E

Emulations, 1-6, A-4

 packaging, 2-6

Energy Timeout, 3-20

Engine Pages, 3-22

Error Messages

 fatal, 4-6

 operator calls, 4-5

F

Factory Settings, 3-14

Fast Busy, 3-35

Features, 1-5

FIFO Trigger, 3-42

Font Memory Menu, 3-44

 Drive B: Fonts, 3-47

 font weight, 3-47

 Installed Fonts, 3-47

 maximum cache memory, 3-45

 maximum cache size, 3-46

 maximum cached characters, 3-46

 maximum character memory, 3-45

 maximum fonts loaded, 3-46

Font Weight, 3-47

Fonts, 1-7, A-4

Forms, 1-7

Fuser Cleaner Felt, 2-16

Fuser Temperature, 3-20

H

Hardware, packaging, 2-6

Hardware Options, 1-6

Hex Dump, 3-30

Hex Dumps, 4-4

Horizontal Image Shift, 3-18

Host Interface Menu, 3-32

 Centronics, 3-33

 Dataproducts, 3-36

 RS-232 serial, 3-39

 RS-422 serial, 3-39

Host Protocol, 3-40

HP PCL 5, 2-20

I

IGP/PGL Emulation, 3-27

IGP/VGL Emulation, 3-28

Image Width, 3-18

Impact Printer Emulation, 3-27

Index-2

Initial Setup, 2-7

Installation

- add starter toner, 2-11
- developer unit, 2-10
- fuser cleaner felt, 2-16
- OPC drum unit, 2-17
- operating system diskette, 2-20
- ozone filter, 2-13
- paper, 2-18
- waste toner container, 2-14

Installed Fonts, 3-47

Instructions

- add starter toner, 2-11
- developer unit installation, 2-10
- fuser cleaner felt installation, 2-16
- initial setup, 2-7
- OPC drum unit installation, 2-17
- ozone filter installation, 2-13
- paper installation, 2-18

Interfaces, 2-21, A-4

- Centronics, B-2
- Dataproducs, B-5
- diagnostic port, B-16
- RS-232 serial, B-9
- RS-422 serial, B-12
- termination resistors, B-8

Interference, checking, 2-23

IPDS, 3-28

L

LAN Connection, 1-7

Language Selection, 3-31, D-1

Load Configuration, 3-24

M

Maintenance Menu

- alarm, 3-29
- display language, 3-31
- hex dump, 3-30
- panel key sound, 3-29
- power-up state, 3-29
- PTX-setup option, 3-31

Maintenance/Miscellaneous Menu, 3-29

Maximum Cache Memory, 3-45

Maximum Cache Size, 3-46

Maximum Cached Characters, 3-46

Maximum Character Memory, 3-45

Maximum Fonts Loaded, 3-46

Media Requirements, C-1

- length, C-1
- moisture content, C-1
- percent recycled, C-1
- resistivity, C-1
- weight, C-1
- width, C-1

Memory Expansion, 1-6

Memory Modules, 1-6

Memory System, 3-48

Messages

- error warnings, 4-5
- fatal errors, 4-6

Mode Emulation, coax/twinax, 3-28

Mode Emulation Menu, IPDS, 3-28

Mode Menu, 3-26

- IGP/PGL emulation, 3-27
- IGP/VGL emulation, 3-28
- impact printer emulation, 3-27
- PCL5 emulation, 3-27

Modifying Saved Parameters, 3-10

N

Number of Buffers, 3–42

O

OPC Drum Unit, 2–17

Operating System Diskette, installing, 2–20

Operator Calls, 4–5

Optional Fonts, 1–7

Options, 1–6, A–4

Coax/Twinax connection, 1–7

disk drive B, 1–7

LAN connection, 1–7

memory expansion, 1–6

optional fonts, 1–7

paper stacker, 1–6

second disk drive, 1–6

Original Manufacturer Supplies, A–1

Output Polarity, 3–34, 3–37

Ozone Filter, 2–13

P

Panel Key Sound, 3–29

Paper, 2–18

Paper Control Menu, 3–17

horizontal image shift, 3–18

image width, 3–18

paper length, 3–18

reprint on fault, 3–18

vertical image shift, 3–18

Paper Instruction Line, 3–34, 3–37

Paper Instruction Pol, 3–35, 3–38

Paper Length, 3–18

Paper Stacker, 1–6

Parity, 3–41

PCL5 Emulation, 3–27

PostScript, 2–20

Power Off Count, 3–22

Power Requirements, 2–3

Power-up

configuration, 3–25

state, 3–29

Precautions, safety, 2–2

Print Configuration, 3–24

Printer

Diagnostics, 4–2

specifications, A–1

Test, 4–3

Transporting, 2–24

transporting

long distance, 2–25

short distance, 2–24

Printer Control Menu, 3–19

energy timeout, 3–20

fuser temperature, 3–20

Printer Languages, 1–6

Printer Settings, 3–5

Printer Specifications

controller, A–2

dimensions, A–3

electrical, A–3

emulations, A–4

environmental, A–3

fonts, A–4

interfaces, A–4

options, A–4

original manufacturer supplies, A–1

power consumption, A–3

printing, A–3

storage media, A–4

Printing, Hex Dumps, 4–4

Index–4

Printing Configuration Parameters, 3–13
Protect Configurations, 3–25
PTX–Setup Option, 3–31

R

Reprint on Fault, 3–18
Requirements
 power, 2–3
 site, 2–4
Resistors, Termination, B–8
RS–232 Serial, 3–39
RS–422 Input, 3–43
RS–422 Serial, 3–39
RTS Function, 3–41, 3–42

S

Safety Precautions, 2–2
Save Configuration, 3–24
Saving Configuration Parameters, 3–7
Second Disk Drive, 1–6
Serial Interface (RS–232), B–9
Serial Interface (RS–422), B–12
Serial Interface Menu
 baud rate, 3–40
 buffer size, 3–42
 data bits, 3–40
 diagnostic, 3–42
 DTR function, 3–41
 DTR polarity, 3–41
 FIFO trigger, 3–42
 host protocol, 3–40
 number of buffers, 3–42
 parity, 3–41

RS–422 input, 3–43
RTS function, 3–41
RTS polarity, 3–42
series 1 delay, 3–43
series 1 idle, 3–43
series 1 polarity, 3–42
stop bits, 3–41
Series 1 Delay, 3–43
Series 1 Idle, 3–43
Series 1 Poll, 3–42
Setup, initial, 2–7
Site Requirements, 2–4
Space on Disk, D–1
Specifications, printer, A–1
Starter Toner, 2–11
Stop Bits, 3–41
Strobe Filter, 3–35, 3–38
Strobe Polarity, 3–34, 3–37
System Info Menu, system memory, 3–48
System Information Menu, 3–48
System Memory, 3–48

T

Termination Resistors, B–8
Test, running the test print, 4–3
Test Print, 3–22
Trailing Edge, 3–35, 3–38
Transporting
 long distance, 2–25
 short distance, 2–24
Transporting Printer, 2–24
Troubleshooting, 4–5
 interference, 2–23

U

Unpacking the Printer, 2–6

V

Vertical Image Shift, 3–18

W

Warnings and Cautions, 1–3

Waste Toner Container, 2–14

.....
PRINTRONIX
17500 CARTWRIGHT ROAD
P.O. Box 19559
IRVINE, CA. 92623-9559
PHONE: 714/863-1900
FAX: 714/660-8682

PRINTRONIX
NEDERLAND BV
P.O. BOX 163, NIEUWEG 283
NL-6600 AD WIJCHEN
THE NETHERLANDS
PHONE: (31) 24-6490111
FAX: (31) 24-6419768

PRINTRONIX A.G.
42 CHANGI SOUTH
STREET 1
CHANGI SOUTH INDUSTRIAL ESTATE
SINGAPORE 486763
PHONE: (65) 542-0110
FAX: (65) 543-0220

VISIT OUR WEBSITE AT:
<http://www.printronix.com>

Free Manuals Download Website

<http://myh66.com>

<http://usermanuals.us>

<http://www.somanuals.com>

<http://www.4manuals.cc>

<http://www.manual-lib.com>

<http://www.404manual.com>

<http://www.luxmanual.com>

<http://aubethermostatmanual.com>

Golf course search by state

<http://golfingnear.com>

Email search by domain

<http://emailbydomain.com>

Auto manuals search

<http://auto.somanuals.com>

TV manuals search

<http://tv.somanuals.com>