



LineJet™
Printers

IGP®/PGL® Technical Reference Manual

LineJet™ Printers

IGP®/PGL® Technical Reference Manual

Hewlett-Packard makes no representations or warranties of any kind regarding this material, including, but not limited to, implied warranties of merchantability and fitness for a particular purpose. Hewlett-Packard shall not be held responsible for errors contained herein or any omissions from this material or for any damages, whether direct, indirect, incidental or consequential, in connection with the furnishing, distribution, performance or use of this material. The information in this manual is subject to change without notice.

This document contains proprietary information protected by copyright. No part of this document may be reproduced, copied, translated or incorporated in any other material in any form or by any means, whether manual, graphic, electronic, mechanical or otherwise, without the prior written consent of Hewlett-Packard.

COPYRIGHT © 2000, HEWLETT-PACKARD CO.

All rights reserved.

Trademark Acknowledgements

IBM is a registered trademark of the International Business Machines Corp.
IGP, LinePrinter Plus, PGL and Printronix are registered trademarks of Printronix, Inc.

Code V is a trademark of Quality Micro Systems, Inc.

Hewlett-Packard and HP are registered trademarks, and LineJet is a trademark of Hewlett-Packard Company.

This product uses Intellifont Scalable typefaces and Intellifont technology. Intellifont is a registered trademark of Agfa Division, Miles Incorporated (Agfa).

CG, Garth Graphic, Intellifont, and Type Director are registered trademarks, and Shannon and CG Triumvirate are trademarks of Agfa Division, Miles Incorporated (Agfa). CG Bodoni, CG Century Schoolbook, CG Goudy Old Style, CG Melliza, Microstyle, CG Omega, and CG Palacio are products of Agfa Corporation. CG Times, based on Times New Roman under license from The Monotype Corporation Plc is a product of Agfa.

Univers is a registered trademark of Linotype AG and/or its subsidiaries.

Letraset is a registered trademark, and Aachen, Revue and University Roman are trademarks of Esselte Pendaflex Corporation.

Futura is a registered trademark of Fundición Tipográfica Neufville, S.A.

ITC Avant Garde Gothic, ITC Benguiat, ITC Bookman, ITC Century, ITC Cheltenham, ITC Clearface, ITC Galliard, ITC Korinna, ITC Lubalin Graph, ITC Souvenir, ITC Tiepolo, ITC Zapf Chancery, and ITC Zapf Dingbats are registered trademarks of International Typeface Corporation.

Albertus, Gill Sans, and Times New Roman are registered trademarks, and Monotype Baskerville is a trademark of The Monotype Corporation Plc, registered in the U.S. Pat. and TM office and elsewhere.

Hiroshige and Marigold are trademarks of AlphaOmega Typography, Inc.



Table of Contents

1	Introduction.....	13
	About this Manual.....	13
	Warnings and Special Information	13
	The IGP/PGL Emulation	13
	Features	13
	How the IGP Operates	14
	Modes of Operation.....	15
	Alphanumeric Data.....	22
	Incremental Data	22
2	Commands	23
	IGP Command Standards.....	23
	Special Function Control Code (SFCC)	23
	Semicolon (;).....	23
	Uppercase	23
	Inline Commands	23
	Line Terminator	24
	Printable Character	24
	Spaces	24
	Command Parameters	24
	Form Name	24
	Prompt.....	25
	Numeric Values.....	25
	Comments in Command Lines.....	25
	Storing Data	25
	Character Position.Dot Position (CP.DP) Format.....	26
	Command Codes.....	27
	Data Fields for Alphanumeric and Incremental Data.....	27
	Dark Printing	28
	Alphanumerics	29
	Alphanumerics, Incremental Fields	34
	Alphanumerics, Incremental: Fixed Data Fields.....	38
	Alphanumerics, Incremental: Dynamic Data Fields.....	40
	Boxes	43
	Compressed Print (Density)	45
	Configuration.....	46

Corners	49
Create	51
Delete Form	52
Delete Logo.....	53
Directory	53
Duplication, Horizontal	54
Duplication, Vertical	56
Emulation Switching.....	57
End.....	57
Execute Form Mode.....	58
Execute Form: General Format.....	59
Execute Form: Electronic Vertical Format Unit	61
Execute Form: Dynamic Alphanumeric Data	62
Execute Form: Dynamic Bar Code Data	63
Execute Form: Dynamic Logo.....	64
Execute Form: Incremental Dynamic Data	65
Execute Form: Overlay Data.....	67
Expanded Print.....	68
Font	69
Form Length.....	70
Ignore Sequence	71
Line Spacing	71
Lines, Horizontal	72
Lines, Vertical.....	73
Listen.....	74
Logo Call	74
Logo Mode, Create	76
Normal Mode.....	78
Page Number	78
Paper.....	79
Paper Instruction - Data Bit 8	79
Paper Instruction (PI) Enable/Disable	80
Print File	80
Quiet.....	81
Recall	81
Reset.....	82
Reverse Print	82
Scale	83
Select Format.....	84
Setup.....	85
Special Function Control Code Change.....	86

3	Bar Codes.....	87
	Overview.....	87
	User-Defined Variable Bar Code Ratios.....	89
	PDF Character Sizes [PDF [;LOC] [;FONT]]	90
	Bar Codes.....	91
	Codabar	91
	Code 39.....	96
	Code 93.....	102
	Code 128A, 128B and 128C	108
	EAN 8.....	118
	EAN 13.....	123
	FIM	129
	Interleaved 2/5 (I-2/5), German I-2/5 and ITF-14	135
	Matrix	141
	MSI.....	147
	PDF417	153
	POSTNET	158
	PostBar and Royal Mail (KIX).....	163
	Telepen	167
	UCC/EAN-128.....	173
	UPC-A	185
	UPC-E and UPC-E0.....	191
	UPCSHIP	198
	UPS 11	203
	Incremental Bar Code Fields	208
	Incrementing Bar Code Data.....	208
	Incremental Bar Code Fixed Data Fields	211
	Incremental Bar Code Dynamic Data Fields	212
	Duplicating Incremental Bar Code Fields.....	214
4	Form Examples and Exercises.....	215
	Form Examples.....	215
	Example: Basic Create Form	215
	Example: Dynamic Data.....	218
	Form Exercise.....	228
	Creating a Box and Corners.....	228
	Adding Horizontal and Vertical Lines	230
	Adding Fixed Alphanumeric Text	231
	Adding a Bar Code	233
	Logo Exercise	236
	Creating a Logo.....	237
	Form Design	239

Page Layout Considerations	239
Planning the Form Layout	239
Creating a Form and Adding Form Components	243
Directory Command.....	247
Example	247
Delete Command.....	248
Example	248
Solving Program Errors	248
Example	249
5 Multinational Character Sets.....	251
Introduction	251
Supported Character Sets.....	251
Character Addresses	252
Making Character Substitutions	252
Accessing Characters and Character Sets.....	253
OCR Character Sets	253
Data Bit 8	253
Power-Up Character Set Selection	253
User-Defined Set Command (USET)	254
Character Set Selection Command (ISET)	256
Multinational Character Sets	257
6 Error Codes	261
IGP/PGL Emulation Error Codes.....	261
Horizontal Line Errors	262
Vertical Line Errors.....	263
Box Errors	264
Corner Errors	265
Alpha Errors	266
Logo Errors	267
Create Errors.....	268
Execute Errors	269
Miscellaneous Errors.....	270
Bar Code Errors	271
Reverse Print Errors.....	273
Incremental Fields Errors	274
Multinational Character Set Errors	274
A Standard ASCII Character Set	277
B Grid Programs and Samples	279

C Vertical Paper Motion.....	283
Introduction	283
Paper Motion Using Line Feeds and Form Feeds	283
Paper Motion Using the PI Line (Relative Line Slewing)	283
Paper Motion Using the EVFU.....	285
General EVFU Programming	285
EVFU Programming Sequence	285
Using the EVFU	286
Clearing the EVFU Memory	288
EVFU Example.....	289



Table of Contents

1

Introduction

About this Manual

This manual explains how to use the IGP[®]/PGL[®] (Intelligent Graphics Printing/Printronix[®] Graphics Language) on line matrix printers. Use this manual and your printer *User's Guide* for complete printer-IGP compatibility.

Warnings and Special Information

Information requiring special attention is indicated under special headings. Always read and comply with this information. The heading reveals the nature of the information:

Warning



Warning messages call attention to situations that could hurt you or damage the equipment.

Caution



Conditions that could damage the printer or related equipment.

Note



A note gives you helpful hints about printer operation and maintenance.

The IGP/PGL Emulation

The IGP/PGL emulation is the software-based Intelligent Graphics Processor (IGP) for the line matrix printers. It is based on, and is compatible with, the Printronix IGP-100/200/400 board using the Printronix Graphics Language (PGL).

Features

On-Line Form and Label Generation makes it easy to create forms or labels with a "preprinted" look for each application. IGP programs control all graphic functions, dramatically reducing host computer programming and processing time.

Graphic capabilities include boxes, vertical and horizontal lines with user-selectable thickness, logos, and special alphanumeric print features. Forms and graphic designs can be duplicated horizontally and vertically.

Alphanumeric data can appear as prepositioned “fixed” information (entered when the form is created), can be overlaid onto the form (positioned in a specific location after the form is created), or may be dynamically merged with the form.

Selectable Bar Codes provide appropriate bar codes for your application, using standard wide-to-narrow ratios. A wide selection of bar codes are available: Codabar; Code 39; Code 93; Interleaved 2 of 5; German I-2/5; ITF-14; FIM; Matrix; MSI A through D; Code 128 Subset A, B, and C; UCC/EAN-128; EAN 8; EAN 13; PDF417; POSTNET; PostBar; Royal Mail; Telepen; UPC-A; UPC-E and UPC-E0; UPCSHIP and UPS 11. UPC and EAN bar codes can also specify add-on data.

Expanded and Compressed Character Print attract attention where needed. Alphanumeric height and width are controlled independently for a wide range of character sizes up to 113 times the standard character size (up to 11.3 inches wide and tall). Compressed print sizes of 12, 13, 15, and 17 characters per inch (cpi) are available.

Rotated Alphanumerics permit new concepts in form design. Normal, expanded, and compressed character strings can be rotated 90 degrees clockwise or counterclockwise, or they can be printed upside down.

Logos are easily created using alphanumeric commands and add a variety of print and shading features for a “customized” appearance to forms, reports, and labels.

Reversed Print permits highlighting and contrasting by printing a dark background around white characters.

Automatic Increment/Decrement Capability allows batch form processing. You can identify individual numeric and bar code data fields, which include automatic increment or decrement functions.

Scaling Capability permits graphic elements, such as corners or boxes, to retain their physical shapes and sizes when printed in a horizontal and vertical density other than the base density of 60 x 72 dpi.

Multinational Character Sets provide 32 international character sets, each 96 characters in length. This feature also allows you to create your own character sets using characters defined and stored in memory.

Extended Character Sets provide 33 extended character sets, these also having 96 characters. These are also stored in memory.

How the IGP Operates

IGP is an emulation that allows printing of sophisticated graphics and bar codes.

The printer performs commands based on the current mode. These modes are discussed in more detail beginning on page 15.

When the printer is receiving or printing text, it is in Normal Mode. Any time the printer is on and is not processing IGP commands, it is in Normal Mode.

When a Create Form command is issued, the printer moves from the Normal Mode to the Create Form Mode.

When in the Create Form Mode, the user sends text, images, and bar code data to the IGP. All of this data is stored in memory. An End statement terminates the IGP data string. The printer returns to Normal Mode.

You can create as many forms as you wish and store them on your host. These forms can then be downloaded from your host to the printer.

When you execute a form, you can print it as many times as you wish. This saves you time downloading the form each time you want to print it.

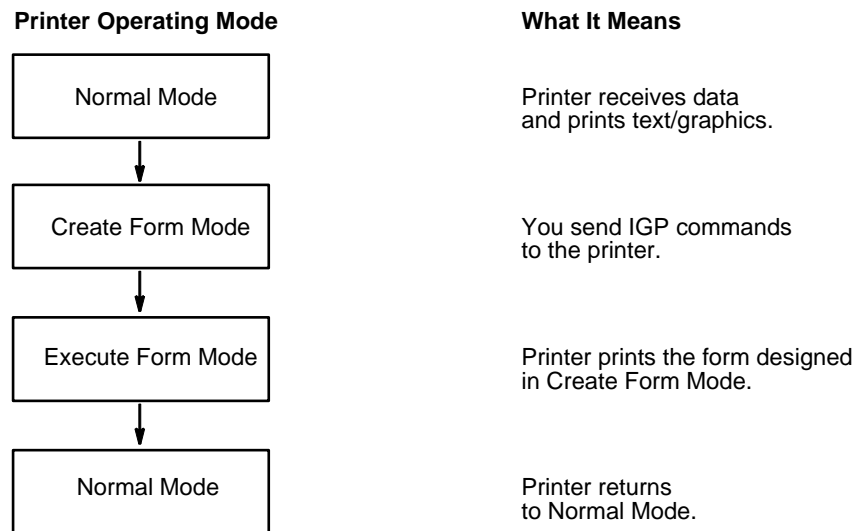

Figure 1. IGP Modes

Modes of Operation

The IGP has five modes of operation that use specific command sequences to control the IGP.

- In the Normal Mode, the printer waits for an SFCC in order to perform IGP functions.
- In Quiet Mode, all IGP commands are ignored except the LISTEN command.
- In the Create Logo Mode the printer produces graphics such as forms, logos, bar codes, and alphanumeric data.
- The Execute Mode is the IGP printing mode, which controls when the actual printing of the bar codes and graphics will occur.
- In Create Form Mode, the printer produces graphics such as forms, logos, bar codes, and alphanumeric data.

Normal Mode

Normal Mode commands print data in a line printer format until a Special Function Control Code (SFCC) is detected.

Commands accessible in the Normal Mode are summarized in Table 1 and fully described on the referenced page. Some Normal Mode commands can also be used in other modes: Compressed Print, Expand, Ignore, Select Format, and Vertical Line Spacing, which are Normal Mode commands, can also be used in the Execute Form Mode; the Multinational Character Set command can be used in the Normal or Create Modes. Carriage Return, Form Feed, Line Feed, EVFU commands, and Paper Slew commands also operate in the Normal Mode.

Note

All IGP commands must be entered in UPPERCASE, and each command line must be followed immediately by a line feed (or carriage return with line feed terminator) or a paper motion command.

Quiet Mode

In this mode, the host processes all data as ASCII characters without any IGP interpretation — the IGP is disabled and all IGP commands are ignored. The IGP looks only for the (cc)LISTEN command.

Table 1. Normal Mode Commands

Command	Mnemonic	Description	Page #
Compressed Print	DENSITY	Defines the horizontal print density in characters per inch (dpi).	45
Configuration	CONFIG	Reconfigures IGP/PGL parameters	46
Create	CREATE	Places the IGP in the Create Form Mode where all the Create Form Mode commands are available to design form elements.	51
Create Logo	LOGO	Places the IGP in the Create Logo Mode, where logos can be defined using the appropriate dot placements.	76
Delete Form	DELETE FORM	Deletes a selected form name from the directory and IGP memory.	52
Directory	DIRECTORY	Provides a list of all defined forms and logos, logo assignments to forms, and memory usage and availability.	53
Emulation Switch	EMULATION	Switch emulation from IGP/PGL to IGP/VGL (if VGL is present)	57
Execute	EXECUTE	Executes a previously created form.	58
Expanded Print	EXPAND	Expands fonts vertically and horizontally.	68
Font	FONT	Selects a specific typeface: bold, slant (italic) factor, and symbol set.	69
Ignore Sequence On/Off	IGON IGOFF	Enables the IGP to ignore all characters after the Ignore Sequence On command is sent until the Ignore Sequence Off command is sent. See note on page 20.	71
Line Spacing, Vertical	LPI	Defines the lines per inch (lpi) printing format.	71
Listen	LISTEN	Removes IGP from the quiet state and enables IGP operation.	74
Multinational Character Set	ISET USET	Use a character set. Create a custom user-defined character set.	Chap. 5
Normal Mode	NORMAL	Places the IGP in the Normal Mode, where it does not change the data stream but awaits the SFCC followed by an IGP command.	78
Paper Instruction Enable/Disable	EN-PI DIS-PI	Enables or disables use of the PI line with a parallel interface.	80
Paper Instruction On/Off for Data Bit 8	PION PIOFF	Enables or disables Data Bit 8 as the paper instruction signal in a serial interface.	79
Print File	PRINT	Prints a file from the flash memory.	80
Quiet	QUIET	IGP operation is disabled until a Listen command is received. Any data sent to the line matrix printer emulation is unaffected by IGP commands.	81
Recall	RECALL	Recalls forms or logos from memory stored in "setup.ptx".	81
Reset	RESET	Deletes all forms and logos from the IGP memory.	82

Table 1. Normal Mode Commands (continued)

Command	Mnemonic	Description	Page #
Special Function Control Code	SFCC	Changes the current Special Function Control Code (SFCC).	86
Select Format On/Off	SFON SFOFF	Ignores all host-generated paper movement commands. See note on page 20.	84
Set Up	SETUP	Automatically executes and loads the IGP/PGL commands into the printer at power-up or after a RESET command is sent.	85

Create Form Mode

Create Form Mode commands design forms, all form components, and bar codes. The forms are not printed in the Create Form Mode; forms are printed in the Execute Form Mode after all form design is completed. To begin form design, access the Create Form Mode using the Create command. The Create command is always used to enter the Create Form Mode to begin form design.

Note

The CREATE command must be entered in UPPERCASE.



Each element has its own specific set of commands and parameters that determine size, location, and content. Listed in alphabetical order, Create Form Mode commands are summarized in Table 2 and fully described on the referenced pages.

Print Boundaries

Print area boundaries exist for the paper size selected. All Create Form Mode commands require you to identify the location for the components in your form. Boundary checking for form elements is performed only when the form length is specified. This ensures that forms can be created regardless of the type of paper you have loaded or margins you have set.

The IGP checks the boundaries before the form is executed to ensure that it will fit on the loaded paper size. If the debug option is used in the create statement, the boundaries are checked against the current paper size. Refer to Appendix C for more information regarding page boundary guidelines.

Create Logo Mode

The Create Logo Mode is used in the Create Form Mode. The Create Logo Mode creates a logo design; this predefined logo is then "called" into a form in the Create Form Mode. (The logo must be defined before it is "called".)

Table 2. Create Form Mode Commands

Command	Mnemonic	Description	Page #
Alphanumerics	ALPHA	Defines size, location, and content of alphanumeric characters and dynamic alphanumeric data fields.	29
Alpha, Incremental	ALPHA	Defines starting data and increment amount for fixed auto-increment fields.	34
Bar Codes	BARCODE	Each bar code type has its own command to define size, location, orientation, and data as described in the "Bar Codes" chapter.	Chap. 3
Boxes	BOX	Defines size, location, and thickness of boxes.	43
Corners	CORNER	Defines vertical and horizontal length, location, and thickness of a set of four corners.	49
Duplication, Horizontal	HDUP	Defines the number of horizontal duplications of an element and the spacing between duplications.	54
End	END	Terminates the Create Form Mode.	57
Form Length	LFORM	Specifies the form length by total number of lines at 6 or 8 lpi.	70
Ignore Sequence On/Off	IGON IGOFF	Enables the IGP to ignore all characters after the Ignore Sequence On command is sent until the Ignore Sequence Off command is sent. See Note on page 20.	71
Lines, Horizontal	HORZ	Defines the location, size, and thickness of horizontal lines.	72
Lines, Vertical	VERT	Defines the location, size, and thickness of vertical lines.	73
Logo Call	LOGO	Specifies the location of a previously defined logo.	74
Multinational Character Set	ISSET	Selects one of the multinational or international character sets.	Chap. 5
Page Number	PAGE	Defines the location for automatically incremented page numbers.	78
Reverse Print	REVERSE	Defines the location for white-on-black printing and selects the background shade.	82
Scale	SCALE	Defines the vertical spacing and horizontal pitch for data positioning in character or dot columns and rows.	83
Select Format On/Off	SFON SFOFF	Ignores all host-generated paper movement commands. See note on page 20.	84

Execute Form Mode

The Execute Form Mode prints forms created in the Create Form Mode. Execute Form Mode commands are summarized in Table 3 and fully described on the referenced pages. Carriage Return, Form Feed, and Line Feed commands also operate in the Execute Form Mode. The EXECUTE Form command *must* be entered in UPPERCASE, and a single line spacing or a line containing overlay data must separate an EXECUTE command from a NORMAL command.

Note

Some systems pad the data stream with characters and spaces. If the IGP file on your system contains padded characters or spaces before the SFCC, this data must be ignored before the IGP can operate. The Ignore Sequence (IGON/IGOFF) command, discussed on page 71, is provided for this purpose. At times you may also need the IGP to ignore host-originated paper movement commands (carriage return, line feed, form feed, etc.) in lengthy data streams. Select Format (SFON/SFOFF) discussed on page 84 is provided for this purpose. In addition, the Quiet command, page 81, can be used to pass data unchanged to the printer.

Table 3. Execute Form Mode Commands

Command	Mnemonic	Description	Page #
Compressed Print	DENSITY	Defines the horizontal print density in characters per inch (cpi).	45
Dynamic Alphanumeric Data	AF <i>n</i>	Executes the dynamic alphanumeric data provided after the (cc) EXECUTE command.	62
Dynamic Bar Code Data	BF <i>n</i>	Executes the dynamic bar code data provided after the (cc) EXECUTE command.	63
Expanded Print	EXPAND	Expands fonts vertically and horizontally.	68
Font	FONT	Selects a specific typeface: bold, slant (italic) factor, and symbol set.	69
Ignore Sequence On/Off	IGON IGOFF	Enables the IGP to ignore all characters after the Ignore Sequence On command is sent until the Ignore Sequence Off command is sent.	71
Incremental Alphanumeric Dynamic Data	IAF <i>n</i>	Executes the incremental dynamic alphanumeric data provided after the (cc) EXECUTE command.	65
Incremental Bar Code Dynamic Data	IBF <i>n</i>	Executes the incremental dynamic bar code data provided after the (cc) EXECUTE command.	65
Line Spacing, Vertical	LPI	Defines the lines per inch (lpi) printing format.	71
Multinational Character Set	ISSET	Selects one of the multinational or international character sets.	Chap. 5
Normal Mode	NORMAL	Places the IGP in the Normal Mode, where it does not change the data stream but awaits the SFCC followed by an IGP command.	78
Reset	RESET	Deletes all forms and logos from the IGP memory.	82
Select Format On/Off	SFON SFOFF	Ignores all host-generated paper movement commands. See note on page 20.	84
SFCC	SFCC	Changes the current Special Function Control Code (SFCC).	86

Alphanumeric Data

Based on the requirements of a specific application, you can use one of three methods to print alphanumeric data on a form: Fixed data, Overlay data, and Dynamic data. These methods are described in more detail in Chapter 2.

- Fixed data prints on each form in the same “prepositioned” location, unless the location changes in the form definition. Company name, address, logo, and phone number are typical examples of alphanumeric data that can be “fixed” onto the form.
- Overlay data is variable alphanumeric data positioned on the page with line feeds and spaces to fit into exact locations. For example, specific data can be “overlayed” onto a blank form as if you were typing data into the appropriate blanks on a preprinted form. Customer names, addresses, and order numbers are examples of data overlayed onto a form.
- Dynamic data is variable data entered into specific locations on each form. Each time the form prints, a command enters new data in those locations. Customer names, addresses, or any type of variable alphanumeric or bar code data can be provided dynamically.

Incremental Data

The incremental data feature allows you to update alphanumeric and bar code data fields in an alphabetical or numeric manner automatically with just one set of data sent from the host computer.

Alphanumeric and bar code incremental fields can be used with fixed (static) data input as part of the Create Form Mode or with dynamic data supplied in the Execute Form Mode.

The incremental fields can be increased or decreased, repeated at specified intervals before updating, and reset to the starting value after a specified number of increments.

2

Commands

IGP Command Standards

IGP commands have many options and a specific format that you must follow to obtain the desired results. Certain elements are standard for all IGP commands. These command standards are described in the following sections. Familiarize yourself with the meaning and use of these standards before operating the IGP.

Special Function Control Code (SFCC)

The SFCC identifies a command directed to the IGP to enable a specific IGP function. Based on the host computer interface requirements, various characters can be selected as the SFCC, such as the caret (^) or a tilde (~). Do not use a nonprintable character as your SFCC.

It is appropriate to place the SFCC command at the beginning of a new line. If the SFCC command is placed anywhere else on the line, at the user's discretion, the data preceding the command will either print or be ignored, depending on how the Skip Command Prefix parameter is set.

The examples in this manual use the tilde as the SFCC; always substitute the actual SFCC required by your system where the tilde is shown. In the general command formats, the SFCC is represented by (cc).

Semicolon (;)

Each parameter (alpha data, options, etc) on the command line is separated by a semicolon. Blank spaces between the semicolon and the next parameter are not allowed. A missing or misplaced semicolon causes an error message.

Uppercase

The IGP/PGL is "case sensitive." ALL commands must be entered in uppercase.

Inline Commands

The SFCC, usually a tilde, is suggested to be the first character on a new line. It may appear anywhere on the command line. There is a configuration option that determines whether any data preceding a command is printed or is ignored.

All IGP commands begin with the Special Function Control Code (SFCC) and must end with a line terminator.

Line Terminator

Each command line must be terminated by a line feed (or a carriage return with a line feed), or a paper motion command. The command line will not be accepted if not properly terminated. Refer to the system controls for your system keyboard and printer configuration codes to determine which key(s) (such as ENTER, LINE FEED, FORM FEED, etc.) perform a line feed, carriage return with line feed, or form feed function.

Printable Character

To print, alphanumeric and bar code data must be enclosed by a printable character (a delimiter). This delimiter is represented by (*D*) in the command format. In this manual, an asterisk (*) is used in most examples as the printable character. (The parentheses are *not* entered.) Any printable character can be used as this delimiter except a slash (/) or the SFCC. The same printable character must be used at both the beginning and end of the text to be printed and can not be used within the text.

Spaces

Spaces are used in the general command formats to visually separate individual command parameters. Supply the appropriate information for the command parameter, but do not enter the spaces in the command sequence; they are shown simply as a visual aid to illustrate where one command parameter ends and another begins.

Command Parameters

Most commands include a number of parameters. Some are optional, and some are required. Each parameter must be separated by a semicolon (;) unless noted otherwise. Throughout this manual, actual commands required for input are shown exactly as they must be entered and all parameters associated with that command are shown in italics. Optional parameters are enclosed in brackets [], but do not enter the brackets.

Parentheses indicate variable data. You have a choice of what to enter, but you must enter something. Do not enter the parentheses by themselves.

Form Name

You must use alphanumeric characters to identify the document (form or logo) you are creating (a maximum of 15 alphanumeric characters). The Form Name is also used to identify the form during the Execute Form Mode. The valid Form Name characters are listed in Table 4 and also apply to Logo Name. The SFCC can also be used in the Form Name. No spaces are allowed between any of the Form Name characters.

Table 4. Valid Form Name Characters

A through Z (upper and lowercase)	Left and right parenthesis ()
0 through 9	Tilde ~
Dollar sign \$	Single quotes ‘ ’
Percent sign %	Exclamation point !
Dash —	Pound sign #
At sign @	Ampersand &
Left and right braces { }	

Prompt

The prompt is the symbol (e.g., a dollar sign, period, or greater than symbol) used to indicate that the host computer is ready for data input. In this manual, the prompt is shown as a period (.).

Numeric Values

In this manual, a lowercase *n* in the command represents a numeric value. If a command parameter includes a lowercase *n*, it must be substituted with an appropriate numeric value. If the lowercase *n* is part of an optional parameter and the option is not selected, a value for *n* is not required.

Comments in Command Lines

To aid in preparation or maintenance of a form or logo, comments can be added to many command lines. Comments must be preceded by a slash (/). However, do not use the /comment feature on lines containing an SFCC (i.e., CREATE, NORMAL, EXECUTE, etc.). Throughout this manual, comments are provided in parentheses beside most command lines for better understanding of IGP operation but should not be included in your IGP files.

Storing Data

To send data to the IGP, use a system command, such as PRINT. (Entering data through the keyboard does not store data in memory.) Once stored in memory, the data remains until deleted, the IGP is reset with RESET command, or until the printer is turned off.

IGP/PGL files can be permanently stored to, deleted from, and retrieved from the printer's flash memory by ending CREATE, CREATE LOGO, DELETE FORM, DELETE LOGO, EXECUTE, and DIRECTORY commands with **;DISK**.

For example, the following command creates a form named ORDER and stores it on the flash memory:

```
(cc)CREATE;ORDER;DISK
```

Executing a form or calling a logo will access the default flash automatically if the object is not found in memory.

Character Position.Dot Position (CP.DP) Format

The CP.DP format is a special parameter available with the IGP commands. CP.DP format allows two elements plotted at nearly the same character location to be offset to eliminate overlapping. Specifying starting and ending rows and columns is its most frequent use.

Each character location is a cell. Each cell is a grid 12 dot rows high by 6 dot columns wide (printing at 6 lpi and 10 cpi). The CP.DP format allows a character cell position (CP) and a specific dot position (DP) within the cell to be identified as shown in Figure 2. The DP portion of the CP.DP format specifies a location down (in reference to rows) and to the right (in reference to columns) within the character cell position.

For example, refer to Figure 2. Suppose a line runs along character position column 13 (CP = 13). At the same time, an alphanumeric string must begin in column 13. With CP.DP format, the alphanumeric string can be offset 2 dot positions (DP = 2) in column 13 to avoid overlap. Specify 13.2 (CP = 13, DP = .2) for the starting column of the alphanumeric string. Similarly, to place a horizontal line 8 dot rows beneath another horizontal line in character row position 11, specify row 11 for one line and row 11.8 for the other line.

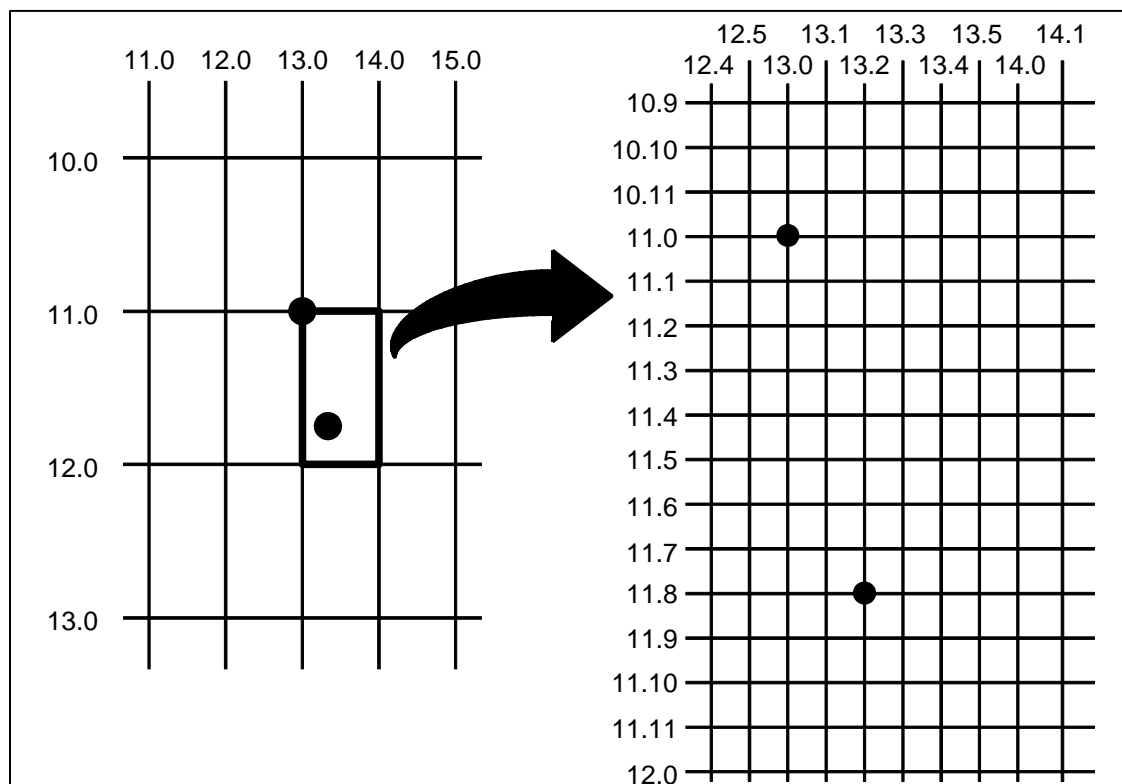

Figure 2. CP.DP Format Example

Command Codes

Data Fields for Alphanumeric and Incremental Data

Based on the requirements of a specific application, three methods are used to print alphanumeric data on the form: fixed (or prepositioned) data, overlay data, and dynamic data.

Fixed Data

Fixed data is entered during the Create Form mode as part of the form definition. It appears as prepositioned information similar to other form elements. The fixed data is printed on each form in the same location and can only be changed by changing the form definition. Your company name, address, logo, or phone number are typical examples of alphanumeric data that can be fixed onto the form.

Overlay Data

Overlay data is variable alphanumeric data entered during the Execute Form mode by positioning the information with line feeds and spaces into an exact location. In general, a page of data is overlaid onto a form similar to typing data in the appropriate blanks of a preprinted form. Each page of overlay data is separated by form feeds to correspond to each form printed. Customer names, addresses, and order numbers are examples of variable data that can be overlaid onto the form.

Dynamic Data

Dynamic data is variable data entered by command during the Execute Form mode. The dynamic data is entered into a location previously defined in the Create Form mode. Any number of locations can be identified during the Create Form mode as part of the form definition. A command during the Execute Form mode enters new data in the identified location(s) each time the form prints. Dynamic data is the most efficient method of supplying variable data to the form. Again, customer names, addresses, or any type of variable alphanumeric or bar code data can be provided dynamically.

Incremental Data Fields

The incremental data fields feature allows alphanumeric (and bar code) data fields to automatically update numerically or alphabetically with just one set of data sent from the host computer. A maximum of 65,535 forms can print with incremental fields automatically updated. Alphanumeric incremental fields can be used with fixed (static) data input as part of the Create Form mode or with dynamic data supplied in the Execute Form mode. Incremental data fields cannot be used with Overlay data.

Dark Printing

A DARK parameter, available in the Alpha, Reverse, and Bar Code commands, is a double-strike feature which produces bolder, darker text, denser black backgrounds for reverse print, and extra-dark, more readable bar codes.

A DARK parameter used with alphanumeric text in the ALPHA command will print using a bold font.

The extra darkness provided by the DARK parameter improves the Print Contrast Ratio (PCR) and effectively extends the life of the ribbon. For bar codes, the PCR describes the difference in light reflection between the bars and spaces as a measurement of light/dark contrast in order to judge when a printed bar code will not be dark enough to be read with accuracy by a scanner. The extra dots used to produce the darker bar code do not change the overall width of the wide bars. Figure 3 illustrates how the DARK parameter adds two extra dot columns to wide bar code bars without increasing bar width.

Due to the second hammer bank stroke required to plot the extra columns of dots, print speed may be reduced up to half when the DARK parameter is used with Bar Code commands. However, this decreased print speed should be weighed against the significant increase in bar code PCR and extended ribbon life.

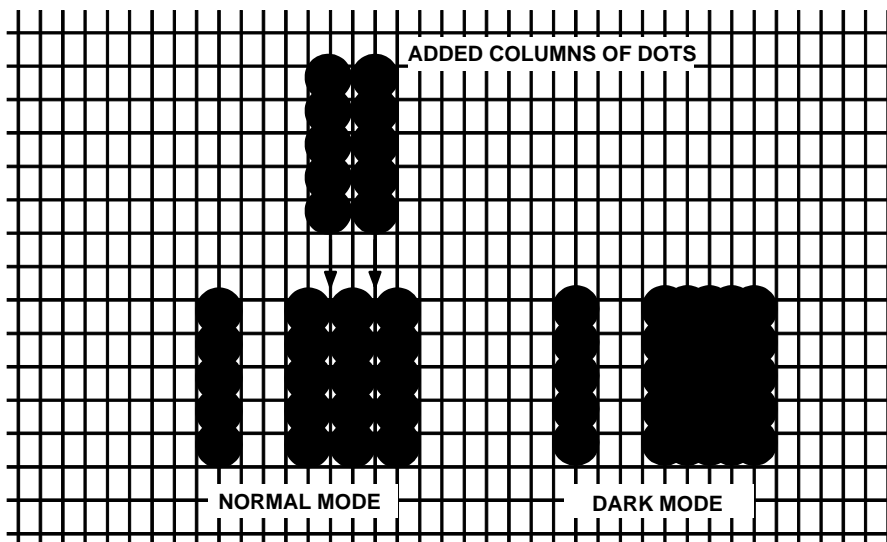

Figure 3. Dark Printing

Alphanumeric

Purpose	Defines and positions alphanumeric data on a form as a “preprinted” static data field or as a dynamic data field.
Mode	CREATE
Format	ALPHA [R;] [E;] [C <i>n</i> ;] [AF <i>n</i> ;L;] [DIR;] [UC;] [DARK;] [POINT;] [HS <i>n</i> ; or HSD <i>n</i> ;] SR; SC; VE; HE; (D)text(D) STOP ALPHA The Alphanumeric command; enter ALPHA. R The optional reverse printing (white on black) parameter. Enter R to specify a black background.

Note

The **D** parameter, used in earlier IGP/PGL versions, is ignored. In addition, the **L** parameter, also used in earlier IGP/PGL versions to specify a long reverse field for descending characters in dynamic alphanumeric data, is provided automatically. The IGP/PGL will ignore these parameters if found in a command line.

E	The optional elongated character parameter. Enter E to specify elongated character printing. Elongated characters are double height and single width. If used, the VE and HE parameters must be set to 0, or an error message will result. Elongated character printing is also available with rotated alphanumerics.
C <i>n</i>	The optional horizontal compression parameter. Enter C and replace <i>n</i> with 10, 12, 13, 15, 17 or 20 to specify the number of horizontal characters per inch (cpi). 10 cpi is the default value. 10A = 10 cpi OCR-A. 10B = 10 cpi OCR-B. If used, the VE and HE parameters must be set to 0, or an error message will result.
AF <i>n</i> ;L	The optional dynamic data field parameters for identifying the alphanumeric string location on a form and for designating the length of the alphanumeric string. If these parameters are used, the actual text can not be entered during the Create Form mode; it must be entered dynamically during the Execute Form mode. Dynamically entering data during the Execute Form mode permits changes to the alphanumeric text without redefining or re-creating the form. To use this field, perform the following steps: <ol style="list-style-type: none"> Enter AF. Replace <i>n</i> with a number ranging from 1 through 512 to identify the alphanumeric string

location on the form. The *SR* and *SC* parameters specify the exact location of the alphanumeric field identified by *n*.

- c. Replace *L* with a number equal to the number of characters in the dynamic alphanumeric string ranging from 1 through 512.
- d. Dynamically enter the alphanumeric string itself in the Execute Form mode. The length of the alphanumeric string must be equal to or less than the value assigned to the length (*L*) parameter. Refer to "Execute Form: Dynamic Alphanumeric Data" on page 62.
- e. If the dynamic data field is used, do *not* enter the ASCII TEXT parameter.

DIR Optional parameter for rotating a character string. Use the following codes to indicate the direction of character rotation:

- a. Enter **CW** for 90 degree clockwise rotation.
- b. Enter **CCW** for 90 degree counterclockwise rotation.
- c. Enter **INV** for inverted characters (180 degree rotation).

The default orientation prints character strings in the standard horizontal format.

UC Enter **UC** to specify uppercase-only characters. When uppercase-only is specified, all lowercase alpha character codes are converted automatically to uppercase. Consequently, do not specify uppercase-only characters if lowercase characters are required.

DARK Optional parameter to produce bolder text. Enter **DARK** or **D**. (**D** is also allowed in the ALPHA command only.) More information about dark printing is provided on page 28.

SR Defines the starting row of the alphanumeric data. Enter a value ranging from row 1 through one less than the length of the form. Character row or dot row is specified based on the Scale command (page 83), or use the CP.DP format (page 26).

SC Defines the starting column of the alphanumeric data. Enter a value ranging from column 1 through one less than the width of the form. Character column or dot column is specified based on the Scale command (page 83), or use the CP.DP format (page 26).

POINT	Optional parameter that changes the units for the vertical and horizontal expansion values. When the point parameter is present the <i>VE</i> value defines the font height in 1/72 of an inch (i.e. points). If the <i>HE</i> value is non-zero, it defines the character width in 1/72 of an inch, otherwise the character width is the standard width for the chosen height. Cannot be used with elongated (E) and compressed (C <i>n</i>) parameters.
H <i>Sn</i> or HSD <i>n</i>	Horizontal Spacing. The value <i>n</i> indicates the number of extra dots to add between each character. HS = the value is in 60 DPI dots HSD = the value is in printer dots.
<i>VE</i>	Defines the vertical expansion factor to enlarge characters vertically. Enter a value between 0 and 113. Zero specifies the standard font (no expansion). A <i>VE</i> value must be entered. Elongated (E) and compressed (C <i>n</i>) characters cannot be used with a vertical expansion other than zero.
<i>HE</i>	Defines the horizontal expansion factor to enlarge characters horizontally. Enter a value between 0 and 113. Zero specifies the standard font (no expansion). An <i>HE</i> value must be entered. Elongated (E) and compressed (C <i>n</i>) characters cannot be used with a horizontal expansion other than zero.
(<i>D</i>)	The printable character (quotation marks for example) identifying the start and finish of the alphanumeric string. Enter any printable character other than a slash (/), the SFCC, or a character used within the alphanumeric string itself. You must use the same character at both ends of the alphanumeric string, but it will not print with the data.
<i>text</i>	The group of ASCII characters (the alphanumeric string) to print. Enter any of the standard ASCII printable characters (except the character used to delimit the string in the D parameter). The data appears as "prepositioned" information on the form beginning at the location specified by <i>SR</i> and <i>SC</i> . This is the "fixed" or static alphanumeric data; once defined on the form, it is changed only by redefining the form using the Alphanumeric command.
STOP	Stop indicates the end of the Alphanumeric command; enter STOP , and the IGP will wait for a new command. If not entered, the IGP will wait for another set of Alphanumeric command parameters.

Comments As dynamic data, the location of the alphanumeric field is established in the Create Form mode and the actual alphanumeric data is continuously redefined before placement on the form in the Execute Form mode. You can also rotate and reverse print the alphanumeric string using this command.

Example The following program and example in Figure 4 illustrates the Alphanumeric command capabilities. To illustrate positioning, starting row and column are indicated on the example but do not necessarily reflect actual location on the page. Notice the same starting row is used for all "EXAMPLE" characters, and they are all aligned on the same baseline (or bottom), regardless of expanded or compressed parameters. The string rotates around the point of intersection of the starting row and columns shown by the "pinwheel" E. A rotated 10 cpi character establishes the baseline for all character sizes.

```

~CREATE;TEST
ALPHA
36;37;4;4;*E*
36;41;2;3;*X*
36;44;2;2;*A*
36;46;1;1;*M*
C13;36;47;0;0;*P*
C15;36;48;0;0;*L*
C17;36;49;0;0;*E*
CW;36;60;2;2;*CLOCK*
CW;42;60;4;4;*WISE*
CCW;58;26;2;3;*COUNTER*
CCW;45;26;2;2;*CLOCK*
CCW;39.2;26;1;1;*WISE*
INV;54.5;58;0;0;*INVERTED*
R;INV;54.5;49;0;0;*REVERSE PRINT*
45;48;0;0;*E*
CW;UC;45;48;0;0;*E*
CCW;45;48;0;0;*E*
INV;45;48;0;0;*E*
STOP
END
~EXECUTE;TEST

~NORMAL

```

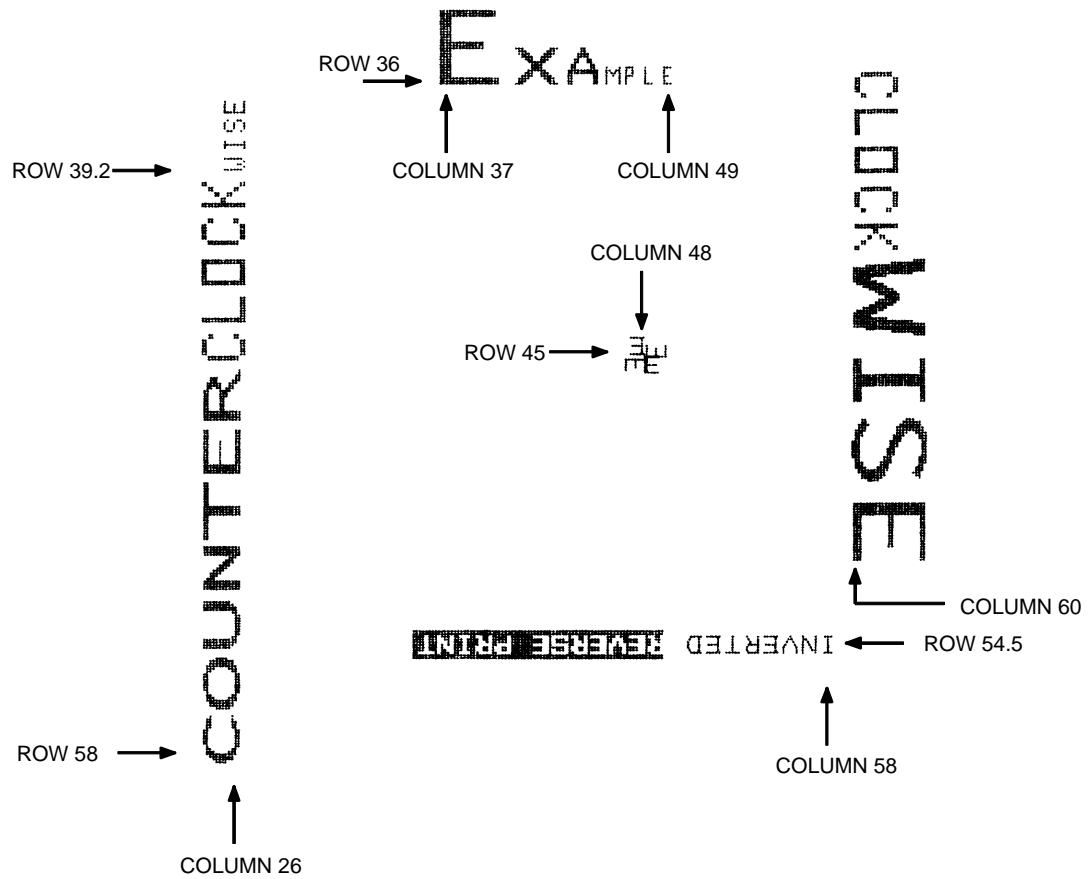



Figure 4. Alphanumeric Example

Alphanumerics, Incremental Fields

Purpose The incremental fields feature updates alphanumeric (and bar code) data fields in a numeric or alphabetical manner automatically using just one set of data sent from the host computer. Incremental alphanumeric data fields can be applied to fixed (static) data (page 38), or dynamic data (page 40).

Mode CREATE (for fixed data) or EXECUTE (for dynamic data)

Note



Throughout the discussion of incremental fields, the term “increment” or “incremental” means the field is automatically updated by a specified amount (or increment). The field can actually be increased/decreased in specified increments/decrements within the command.

Comments Incremental fields can increase or decrease, repeat at specified intervals before updating, and reset to the starting value after a specified number of increments. A maximum of 65,535 fields can print.

Using Incremental Alphanumeric Data

Incrementing is controlled with the STEPMASK and STARTDATA command parameters as described in Table 5. The parameters are part of the Incremental Alphanumeric Fixed Data command or part of the Execute command when using incremental alphanumeric dynamic data.

The STEPMASK parameter performs the following three functions:

1. Defines the increment amount (step);
2. Defines the number of characters allowed in the data field (STARTDATA); and
3. Provides a “mask” to link or unlink subfields of the data to be incremented independently. The data provided in the STEPMASK field combined with the data in the STARTDATA field determine the result of these functions.

The increment amount is defined by the numeric value of the STEPMASK data. For example, a STEPMASK value of 1 increments the STARTDATA by 1; a STEPMASK value of 2 increments the STARTDATA by 2.

The maximum number of characters allowed in the STARTDATA field is defined by the number of characters in the STEPMASK field; the STARTDATA field cannot contain more characters than used in the STEPMASK field.

Linked and unlinked masking of subfields within the STARTDATA is defined by the L value in the STEPMASK field. L indicates linked but non-incremental data in the corresponding position of the STARTDATA field; any alpha character other than L in the STEPMASK field indicates a non-incremental, non-linked STARTDATA subfield.

Table 5. Increment Alphanumeric

STEMASK	START DATA	Character Type and Function
0 - 9	A - Z	Alpha characters incremented by amount in STEPMASK field
0 - 9	0 - 9	Numeric characters incremented by amount in STEPMASK field
0 - 9	Space	Same character type as character in the next right adjacent, linked increment position. Character type will be numeric if in least significant position.
0 - 9	Not A - Z or 0 - 9	Error
Not 0 - 9 or L	Any	Non-incrementing alphanumeric character
L	Any	Linked, non-incrementing alphanumeric character

The examples on the following pages illustrate incremental alphanumeric data fields. All cases in the examples use a repeat count parameter value of 1 and a reset count parameter value of 0. The three vertical dots illustrate the natural progression for each column and unit of data based on the incremental count and its impact on linked and unlinked data fields.

	Value	Description
STARTDATA:	ABC123	<i>Linked subfields: ABC and 123</i>
STEPMASK:	000001	
Printed Results:	ABC123	<i>RPT = 1</i>
	ABC124	<i>RST = 0</i>
	
	
	
	ABC999	
	ABD000	
	
	
	
	ZZZ999	
	AAA000	

	Value	Description
STARTDATA:	1ABC123	<i>Two separate but linked numeric subfields: 1 and 123, while fixed data ABC is nonincrementing</i>
STEPMASK:	0LLL001	
Printed Results:	1ABC123	<i>RPT = 1</i>
	1ABC124	<i>RPT = 0</i>
	. . .	
	. . .	
	. . .	
	1ABC999	
	2ABC000	

	Value	Description
STARTDATA:	ABC123	<i>Two separate unlinked subfields: ABC and 3, while fixed data 1 and 2 is nonincrementing</i>
STEPMASK:	001XX1	
Printed Results:	ABC123	<i>RPT = 1</i>
	ABD124	<i>RPT = 0</i>
	. .	
	. .	
	. .	
	ABI129	
	ABJ120	

	Value	Description
STARTDATA:	__1	<i>Single numeric field with leading spaces ()</i>
STEPMASK:	0001	
Printed Results:	__1	<i>RPT = 1</i>
	__2	<i>RPT = 0</i>
	
	
	
	__10	

	Value	Description
STARTDATA:	__AA98	<i>Two separate but linked numeric subfields: AA and 98, with leading space (); fixed data AA is nonincrementing</i>
STEPMASK:	0LL01	
Printed Results:	__AA98	<i>RPT = 1</i>
	. . .	<i>RST = 0</i>
	. . .	
	. . .	
	1AA00	

	Value	Description
STARTDATA:	__42AR	<i>Two separate but linked alpha subfields: A and R, with leading space (); fixed data 42 is nonincrementing</i>
STEPMASK:	0LL01	
Printed Results:	__42AR	<i>RPT = 1</i>
	__42AS	<i>RST = 0</i>
	. . .	
	. . .	
	. . .	
	__42ZZ	
	A42AA	

	Value	Description
STARTDATA:	9AA02	<i>Single numeric field decremented by 1, while fixed data 9 and AA are nonincrementing.</i>
STEPMASK:	-XXX01	
Printed Results:	9AA02	
	9AA01	
	9AA00	
	9AA99	
	. .	
	. .	
	. .	
	9AA03	

Alphanumerics, Incremental: Fixed Data Fields

Purpose To automatically increment/decrement fixed alphanumeric data fields.

Mode CREATE

Note



In the command format below, incremental alphanumeric command parameters are shown in **boldface** type. Standard alphanumeric command parameters and optional nonincremental parameters are shown in *italics* and are described in the Alphanumerics section (starting on page 29). Due to space constraints, the command parameters are separated into two lines. During actual IGP input, DO NOT separate command parameters.

Format *ALPHA*
[R;] [E;] [Cn;] I; [DIR;] [UC;] [DARK;] [POINT;] [HSn or HSDn;]
*SR; SC; VE; HE; [idir] **STEPMASK**; [RPTn;] [RSTn;]*
(D)STARTDATA(D)
STOP

I Identifies this alphanumeric command as an Incremental Alphanumeric command; enter **I**.

idir The optional increment direction parameter to specify an increment (add) or decrement (subtract) to the data. Enter a plus sign (+) or leave the field blank to increment (the default). Enter a minus sign (-) to decrement.

STEPMASK Defines the increment amount (step), the number of character positions in the data field, and provides a mask to control the increment function on specific parts of the data. Refer to Table 5 on page 35 for complete information on STEPMASK parameter values.

RPTn The optional incremental repeat count parameter to specify the number of times a particular field value is repeated before it is incremented. A repeated field value is useful when printing multiple rows/columns of identical labels before increasing to the next value.

To use the repeat count parameter, enter **RPT** and replace **n** with a numeric value ranging from 1 to 65,535 to specify the repeat count. The default repeat count parameter is 1, which will increment the field value each time it prints.

RST n The optional incremental reset count parameter to specify the number of times an incremented field is printed (on one or more forms) before it is reset to the starting value. A reset count is useful when printing a hierarchy of fields where a low-level field generates a sequence of numbers, is reset, and the next higher field level is incremented (such as in a unit/box/carton application). To use the reset count parameter, enter **RST** and replace n with a number ranging from 1 to 65,535 to specify the reset count. The default reset count value is 0.

STARTDATA Defines the starting value of the incrementing field. Enter the appropriate value. Refer to "Using Incremental Alphanumeric Data" on page 34 for complete information on STARTDATA and STEPMASK parameter values.

The maximum amount of STARTDATA characters must be equal to or less than the number of characters in the STEPMASK field. If the number of data characters is less than the number used in STEPMASK, the data will print right justified with preceding spaces. Characters allowed for incrementing fields (STEMASK values of 0 - 9) are numeric 0 - 9 and alpha A - Z (uppercase only). Any printable character is allowed in nonincrementing fields (STEMASK values not 0 - 9). The STARTDATA must be enclosed within standard printable character delimiters just as a standard alphanumeric data field is enclosed within delimiters.

Comments The Incremental Alphanumeric Fixed Data Fields command is a revised version of the standard IGP alphanumeric command, but it does not replace the standard alphanumeric command.

```
~CREATE;TEST;288
VDUP;3;6
ALPHA
I;6;5;4;4;-00001;*12345*
STOP
VDUP;OFF
END
~EXECUTE;TEST

~NORMAL
```

12345

12344

12343

Alphanumerics, Incremental: Dynamic Data Fields

Purpose Automatically increments/decrements dynamic alphanumeric data fields. Specifies the location and size of the incremental dynamic data field during the Create Form mode. STEPMASK and STARTDATA parameters are supplied in the Execute command during the Execute Form mode.

Mode CREATE

Note



In the command format below, incremental alphanumeric command parameters are shown in **boldface** type; standard alphanumeric command parameters and optional nonincremental parameters are shown in *italics*.

Format *ALPHA*
*[R;] [E;] [Cn;] **IAFn;L**; [DIR;] [UC;] [DARK;] [POINT;]*
[HSn or HSDn;]SR; SC; VE; HE STOP

IAFn;L Identifies this alphanumeric command as an Incremental Alphanumeric Dynamic Data Field command. The command parameter string identifies the incremental dynamic data field location on the form and defines the length of the alphanumeric data. If these parameters are used, the STEPMASK and STARTDATA parameters can not be entered in the Create Form mode; they are entered dynamically during the Execute Forms mode. To use the incremental dynamic data field, perform the following steps:

- a. Enter **IAF** to specify an incremental alphanumeric dynamic data field.
- b. Replace *n* with a number ranging from 1 through 512 to identify the alphanumeric string location on the form. The standard alphanumeric SR and SC command parameters specify the exact location of the field identified by *n*.
- c. Replace **L** with a number equal to the number of characters in the dynamic alphanumeric string (STARTDATA) ranging from 1 through 280.
- d. Dynamically enter the STEPMASK and STARTDATA parameters in the Execute Form mode. The length of the data must be equal to or less than the value assigned to the length (**L**) parameter. Refer to "Execute Form: Incremental Dynamic Data" on page 65 for more information.

Comments The Incremental Alphanumeric Dynamic Data Fields command is a variation of the standard IGP Alphanumeric command, but does not replace the standard alphanumeric command.

As with standard dynamic data fields, incremental dynamic data fields allow the starting data to be changed without changing the form definition program. Increment parameters can also change with each new job without changing the form definition program.

Duplicating Incremental Alphanumeric Fields — Incremental alphanumeric fixed and dynamic data fields are duplicated horizontally using the HDUP command and vertically using the standard VDUP command. Duplicated incremental fields increment in left-to-right, top-to-bottom order. The following examples illustrate the results of duplicated incremental fields.

	Value	Description
STARTDATA:	01	<i>Single numeric field (01)</i>
STEPMASK:	01	<i>RPT = 1</i>
		<i>RST = 0</i>
Printed Results:		<i>HDUP = 3</i>
		<i>VDUP = 2</i>
<i>Page #1:</i>	01 02 03	
	04 05 06	
<i>Page #2:</i>	07 08 09	
	10 11 12	

	Field A	<i>Unlinked subfields, alpha (A), numeric (01)</i>
STARTDATA:	A01	<i>RPT = 3</i>
STEPMASK:	X01	<i>RST = 9</i>
		<i>HDUP = 3</i>
		<i>VDUP = 3</i>
	Field B	<i>Unlinked subfields, alpha (B), numeric (01)</i>
STARTDATA:	B01	<i>RPT = 1</i>
STEPMASK:	X01	<i>RST = 0</i>
Printed Results:		<i>(No HDUP or VDUP)</i>
<i>Page #1:</i>	A01 A01 A01 B01	
	A02 A02 A02	
	A03 A03 A03	
<i>Page #2:</i>	A01 A01 A01 B02	
	A02 A02 A02	
	A03 A03 A03	

Example The following program will produce the Incremental Alphanumeric data example shown above. The program elements are also defined. (Refer to the command format on page 38.)

```

~CREATE;TEST
HDUP;3;6
VDUP;3;1
ALPHA
I;1;1;0;0;001;RPT3;RST9;*A01*
STOP
VDUP;OFF
HDUP;OFF
ALPHA
I;1;18;0;0;001;RPT1;*B01*
STOP
END
~EXECUTE;TEST;2

~NORMAL

```

where:

I;1;1;0;0;001;RPT3;RST9;*A01*

Incremental alphanumeric command;

SR of **1**; SC of **1**;

VE and HE are **0**;

001 stepmask increments by **1**;

RPT3 repeats each field value 3 times;

RST9 prints and increments each field 9 times before resetting;

A01 is the starting value.

I;1;18;0;0;001;RPT1;*B01*

Incremental alphanumeric command;

SR of **1**; SC of **18**; VE and HE are **0**;

001 stepmask increments by **1**;

RPT1 repeats each field value once;

RST0 is not used (default value is 0), prints and increments continuously without resetting;

B01 is the starting value.

```

~CREATE;TEST;288
VDUP;3;6
ALPHA
IAF1;5;6;5;4;4
STOP
VDUP;OFF
END
~EXECUTE;TEST
~IAF1;+00002;*45678*

~NORMAL

```

45678

45680

45682

Boxes

Purpose	Produces any variety of rectangular boxes.
Mode	CREATE
Format	BOX <i>LT; SR; SC; ER; EC</i> STOP
BOX	The Box command; enter BOX . Boxes expand down and to the right from the given row and column.
<i>LT</i>	Defines the line thickness, measured in dots. Line thickness is based on dot dimensions of 1/72 inch both horizontally and vertically, so that line thickness is equal in both directions. Enter a value of 1 or greater.
<i>SR</i>	Defines the starting row of the box. Enter a value ranging from row 1 through one less than the length of the form. Character row or dot row is specified based on the Scale command (page 83), or use the CP.DP format (page 26).
<i>SC</i>	Defines the starting column of the box. Enter a value ranging from column 1 through one less than the width of the form. Character column or dot column is specified based on the Scale command (page 83), or use the CP.DP format (page 26).
<i>ER</i>	Defines the ending row of the box. Enter a value ranging from row 2 through the last row of the form. The ending row must be greater than the starting row. Character row or dot row is specified based on the Scale command (page 83), or use the CP.DP format (page 26).
<i>EC</i>	Defines the ending column of the box. Enter a value ranging from column 2 through the last column of the form. The ending column must be greater than the starting column. Character column or dot column is specified based on the Scale command (page 83), or use the CP.DP format (page 26).
STOP	Stop indicates the end of the Box command; enter STOP , and the IGP will wait for a new command. If not entered, the IGP will wait for another set of Box command parameters.

Example The following program and example in Figure 5 defines two boxes. To illustrate positioning, the starting row and column are indicated on the example but do not necessarily reflect actual location on the page. (Note the position of the ending row and column.)

```
BOX
3;24;16;51;63      (One box three dot rows thick)
2;44;48;46;58      (One box two dot rows thick)
STOP
```

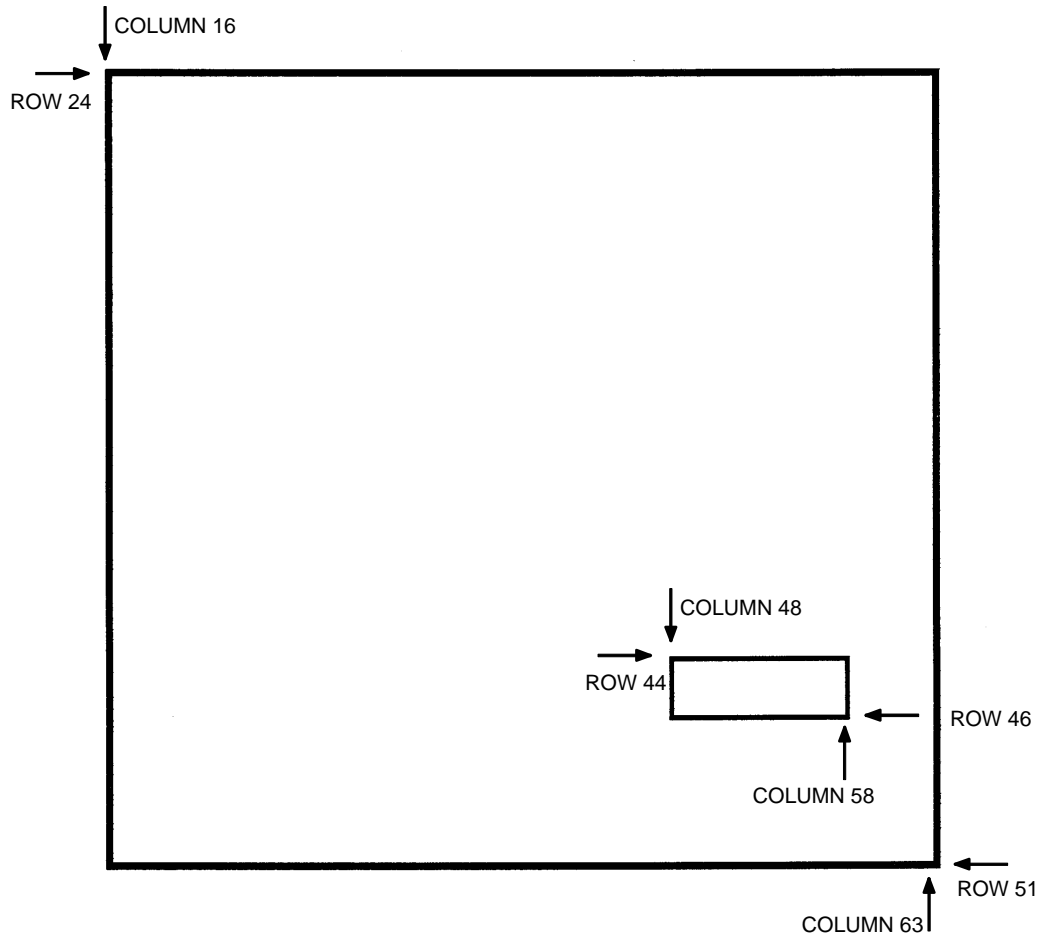

Figure 5. Box Example

Compressed Print (Density)

- Purpose** Defines the horizontal print density in characters per inch (cpi).
- Mode** NORMAL, EXECUTE
- Format** (cc) DENSITY;*n*
- (cc) The Special Function Control Code.
- DENSITY The Density command; enter **DENSITY**.
- n* Selects the density in cpi, OCR-A, or OCR-B; enter a value of **10**, **12**, **13**, **15**, **17**, or **20** to specify the density in characters per inch (the default is 10 cpi), or **10A** to select 10 cpi OCR-A or **10B** to select 10 cpi OCR-B.
- Comments** Print density formats of 10, 12, 13, 15, 17, or 20 cpi are available. Standard print density is 10 cpi. After a Density command is entered, all subsequent alphanumerics print at the specified density until another Density command, a Normal mode command, or a Reset command is entered. The Density command also permits the standard printer editing function (carriage return editing). After the Density command is entered, data in the print buffer can be edited as described in your printer *User's Guide*.
- Example** The following command selects 15 cpi printing format until another Density command, a Normal mode command, or a Reset command is entered.

```
~DENSITY;15
```

Configuration

Purpose Places the IGP/PGL in the Configuration mode, where changes to any or all of the IGP/PGL configuration parameters via software control can be made instead of from the printer control panel.

Mode NORMAL

Note



A separate line is required for the CONFIG command, the parameters and values, and the END command.

Format (cc)CONFIG
parameter;value
END

(cc) The SFCC.

CONFIG The Configuration command; enter **CONFIG**.

parameter;value

The parameter for which a configuration change is desired, and the value associated with that parameter. The available parameters and the values associated with these parameters are listed in Table 6.

END Terminates the CONFIG command; enter **END**.

Note



All CONFIG parameters except RESET must be followed by a semicolon (;). Any CONFIG parameters not entered in UPPERCASE and exactly as listed in Table 6 will result in an Error 156. (Refer to the "Error Codes" chapter.)

Table 6. Configuration Parameters

Configuration Parameter	Value
AI 00 SPACES	0 = Disabled; Non-Zero = Enabled
AUTO WRAP	0 = Disabled; Non-Zero = Enabled
CARRIAGE RETURN DEF	0 = Disabled; Non-Zero = Enabled
CR EDIT	0 = Disabled; Non-Zero = Enabled
ERROR REPORT	0 = Off; 1 = On; 2 = Debug
EXT EXECUTE COPY	0 = Disabled; Non-Zero = Enabled
HOST FORM LENGTH	0 = Disabled; Non-Zero = Enabled
IGNORE CHAR	0-255 = the selected ignore char; any other value = ignore mode off
IGP100 COMPATBL	0 = Disabled; Non-Zero = Enabled
I-2/5 SELECTION	1 = Trailing Spaces 2 = X2DPD 3 = Modulo 7 CD any other value = Leading Zero
LINE FEED DEF	0 = Disabled; Non-Zero = Enabled
LPI	6, 8, 9 or 10
OPTIMIZED RATIO	0 = Disabled; Non-Zero = Enabled
PRINTER PI LINE	0 = Disabled; Non-Zero = Enabled
SFCC	1-255
SKIP PREFIX	0 = Disabled; Non-Zero = Enabled
SLASH ZERO	0 = Disabled; Non-Zero = Enabled
SLEW RANGE	0 = 15; Non-Zero = 16
SO CHAR	0 = Disabled; Non-Zero = Enabled
TRUE FORM SLEW	0 = Disabled; Non-Zero = Enabled
UPPERCASE	0 = Disabled; Non-Zero = Enabled
POWER ON IGP/PGL	0 = Disabled; Non-Zero = Enabled
UPC DESCENDERS	0 = Disabled; Non-Zero = Enabled

Comments The IGP/PGL configuration parameters available are defined in your *User's Guide*.

Any or all parameters can be used within one CONFIG command, and they can be listed in any order. List each *parameter;value* on a separate line, terminating with the END command. Default configuration values can be reset using the CONFIG command.

Parameters not followed by a value, and parameters followed by any non-zero value are interpreted as “true” or “enabled” values. For carriage return and line feed definitions, a zero value does not change the data stream. However, for non-zero values, a carriage return character or line feed character will be interpreted as a carriage return plus a line feed.

Parameters not listed in this command remain unchanged. If a parameter error is detected for parameters other than 0 or 1 (i.e., SFCC, Top/Bottom Margin, Left Margin), the value will default to the current configuration from disk/flash.

Example 1 The following command enables IGP/PGL Auto Wrap, disables Auto Eject, and selects 6 lpi printing.

```
~CONFIG
AUTO WRAP;1
AUTO EJECT;0
LPI;6
END
```

Example 2 The following command resets all control panel IGP/PGL configuration parameters back to default values.

```
~CONFIG
RESET
END
```

Corners

Purpose	Defines corner sets.
Mode	CREATE
Format	CORNER <i>LT; SR; SC; ER; EC; VL; HL</i> STOP
CORNER	The Corner command; enter CORNER . Corners expand down and to the right from the given row and column.
<i>LT</i>	Defines the line thickness, measured in dots. Line thickness is based on dot dimensions of 1/72 inch both horizontally and vertically, so that line thickness is equal in both directions. Enter a value of 1 or greater.
<i>SR</i>	Defines the starting row of the corner. Enter a value ranging from row 1 through one less than the length of the form. Character row or dot row is specified based on the Scale command (page 83), or use the CP.DP format (page 26).
<i>SC</i>	Defines the starting column of the corner. Enter a value ranging from column 1 through one less than the width of the form. Character column or dot column is specified based on the Scale command (page 83), or use the CP.DP format (page 26).
<i>ER</i>	Defines the ending row of the corner. Enter a value ranging from row 2 through the last row of the form. The ending row must be greater than the starting row. Character row or dot row is specified based on the Scale command (page 83), or use the CP.DP format (page 26).
<i>EC</i>	Defines the ending column of the corner. Enter a value ranging from column 2 through the last column of the form. The ending column must be greater than the starting column. Character column or dot column is specified based on the Scale command (page 83), or use the CP.DP format (page 26).
<i>VL</i>	Defines the length of the vertical arm (including the line thickness) of each corner in the set. Enter a value of 1 or greater specified in character or dot rows based on the Scale command (page 83), or use the CP.DP format (page 26).
<i>HL</i>	Defines the length of the horizontal arm (including the line thickness) of each corner in the set. Enter a value of 1 or greater specified in character or dot columns based on the Scale command (page 83), or use the CP.DP format (page 26).

STOP Stop indicates the end of the CORNER command; enter **STOP**, and the IGP will wait for a new command. If not entered, the IGP will wait for another set of Corner command parameters.

Example The following program specifies a corner set as shown in Figure 6. To illustrate positioning, the starting row and column are indicated on the example but do not necessarily reflect actual location on the page. (Note the position of the ending row and ending column; they do not include the line thickness.)

```
CORNER
5;27;27;42;55;4;6 (Each corner in the set is 5
STOP              dot rows thick, 4 character
                  rows high, 6 character
                  wide)
```

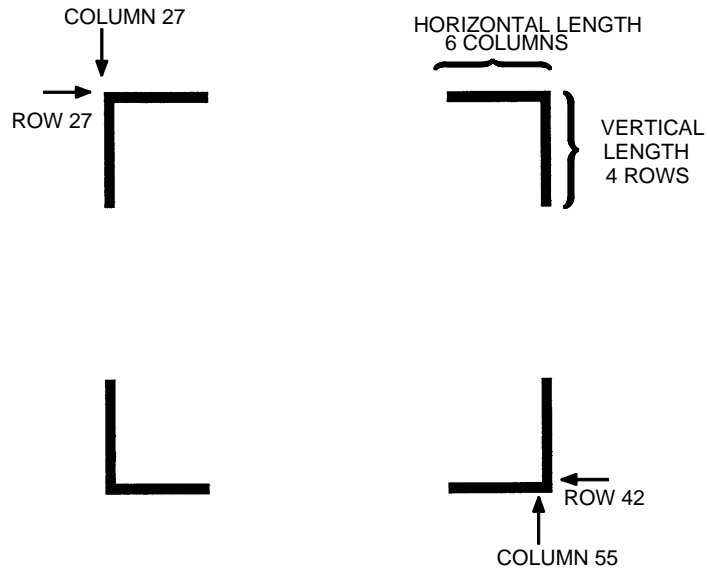

Figure 6. Corner Example

Create

Purpose	Places the IGP in the Create Form mode, where forms and form elements can be defined using the appropriate commands.
Mode	NORMAL
Format	(cc)CREATE; [/] <i>formname</i> [; <i>FL</i>] [;DISK]
	(cc) The Special Function Control Code.
	CREATE The Create Form mode command; enter CREATE .
	/ The optional debug character to check the program line by line for incorrect parameters and print boundaries using the current page size; enter the slash symbol (/) to debug the program. No checks are made until the completed program is sent to the IGP for storage (when the form is executed by printing the file with the IGP program). Then the form name is entered into the directory, and the program is evaluated. If errors are detected, the program will print, line by line (including the error on the line where the error occurs), followed by the error-free sections of the form. Correct all errors and delete the slash. Refer to "Solving Program Errors" on page 248.
	<i>formname</i> Defines the form name of the form being created. The form name should be no more than 15 characters in length. Refer to page 24 for a list of allowable form name characters. If a form is created with the same name as a form already existing in memory, the newly created form will replace the existing form. All future reference to the form (editing, executing, or deleting the form from the directory) must be made using the assigned name.
	<i>FL</i> The optional forms length parameter to specify the maximum length of the form. (Form length cannot exceed the physical length of the page). Specify the form length in one of three ways: <ul style="list-style-type: none"> a. Enter 0 to define a form of unspecified length. The form will end after the longest element; that is, the form length is automatically controlled to contain all elements without extra length beyond the longest element. This can be used to eliminate wasted paper after producing short forms. b. Enter a value for the form length ranging from 1 through 65,535 to specify the forms length in dot rows. (12 dot rows per line = 6 lpi spacing; 9 dot rows per line = 8 lpi spacing.)

- c. To specify the default forms length of 792 dot rows (11 inches at 6 lpi), do not enter a value in the form length parameter.

DISK Optional parameter to store the form on the printer's flash memory. Enter **DISK**.

Example The following command creates a form named ORDER with the default forms length:

```
(cc)CREATE;ORDER
```

Delete Form

Purpose Deletes the form identified by the form name from the directory and the IGP memory.

Mode NORMAL

Format (cc)DELETE FORM; *formname* [;DISK]

(cc) The Special Function Control Code.

DELETE FORM

The Delete Form command; enter **DELETE FORM**.

formname Identifies the form to be deleted. Enter the name of the form exactly as it was created. You can delete an entire form directory by inputting ***ALL** as the form name.

DISK Optional parameter to delete the form from the flash memory where it was originally stored. Enter **DISK**.

Comments For more information, refer to the Directory Example on page 247 and the Delete Example on page 248.

Example The following command deletes the form named "PAY#" from the directory, IGP memory, and the printer's flash memory.

```
~DELETE FORM;PAY#;DISK
```

Delete Logo

- Purpose** Deletes the logo identified by the logo name from the directory and the IGP memory.
- Mode** NORMAL
- Format** (cc)DELETE LOGO; *logoname* [;DISK]
 (cc) The Special Function Control Code.
 DELETE LOGO
 The Delete Form command; enter **DELETE LOGO**.
logoname Identifies the logo to be deleted. Enter the name of the logo exactly as it was created. You can delete an entire logo directory by inputting ***ALL** as the logo name.
 DISK Optional parameter to delete the logo from the flash memory where it was originally stored. Enter **DISK**.
- Comments** Printing a form that contains a deleted logo will produce an error message. For more information, refer to the Directory Example and the Delete Example on pages 205 and 207.
- Example** The following command deletes the logo named "MEMO" from the directory, IGP memory and the printer's flash memory.
 ~DELETE LOGO;MEMO;DISK

Directory

- Purpose** Prints the following information: (1) all defined forms and logos, (2) logo assignment to forms, and (3) memory usage and availability.
- Mode** NORMAL
- Format** (cc)DIRECTORY [;DISK]
 (cc) The Special Function Control Code.
 DIRECTORY The Directory command; enter **DIRECTORY**.
 DISK Optional parameter to specify the forms and logos stored on the flash memory. Enter **DISK**.
- Comments** As many forms and logos as printer memory allows may be stored in IGP memory. If the memory is full, the form will not print; available space in the memory must be at least the size of the form being executed.
 For more information, refer to the Directory Example on page 247.

Duplication, Horizontal

Purpose	Defines both the number of times form elements are duplicated horizontally and the spacing between each duplication.
Mode	CREATE
Format	HDUP; <i>dup#</i> ; <i>offset#</i> <i>elements to be duplicated</i> HDUP;OFF
HDUP	The Horizontal Duplication command; enter HDUP .
<i>dup#</i>	Specifies number of times the entered form element(s) will repeat horizontally. Enter a value ranging from 1 through 512.
<i>offset#</i>	Specifies the horizontal offset to establish the horizontal spacing between each duplication of the form element(s) specified in the body of the command. Enter a value in terms of dot or character columns based on the Scale command (page 83), or use the CP.DP format (page 26). The offset is from starting column to starting column.
HDUP;OFF	Terminates the Horizontal Duplication command; enter HDUP;OFF . If not entered, the IGP expects another form element to be defined for duplication. A single HDUP command can define different types of elements for duplication.

Example The following example is a horizontal duplication of a series of vertical lines. To illustrate positioning, starting row and column are indicated on the example but do not necessarily reflect actual location on the page.

```

HDUP;14;4          (14 dupes with 4-character column spacing)
VERT              (Command to be duplicated horizontally)
1;10;59;59.6     (Note CP.DP format: 59.6)
1;10.3;58.9;59.9
1;11;58.6;60
1;11.3;58.3;60.3
1;12;58;60.6
1;12.3;58.3;60.3
1;13;58.6;60
1;13.3;58.9;59.9
STOP             (Terminates the duplicated element command)
HDUP;OFF        (Terminates the horizontal duplication)
    
```

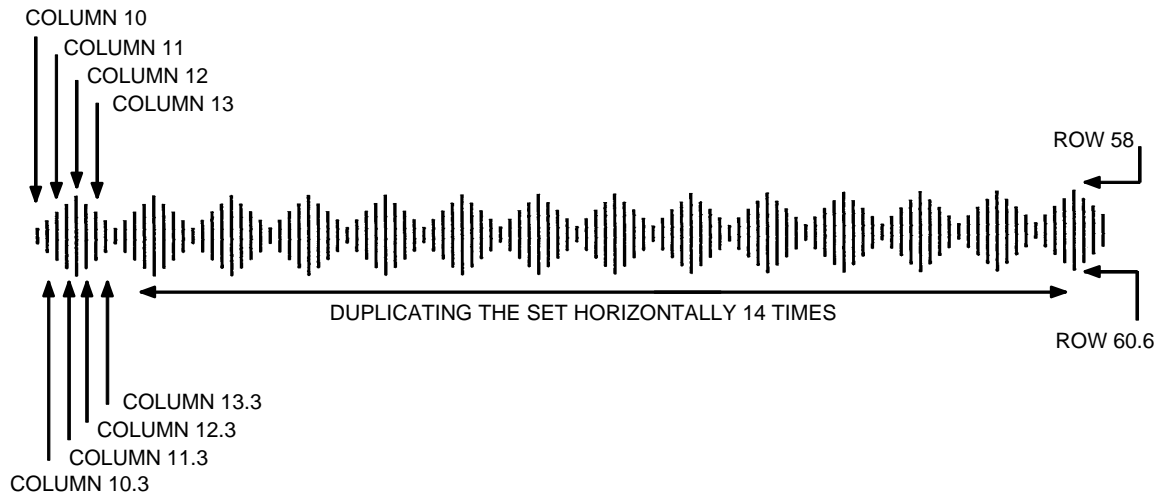

Duplication, Vertical

Purpose	Defines both the number of times elements are duplicated vertically and the spacing between each duplication.
Mode	CREATE
Format	VDUP; <i>dup#</i> ; <i>offset#</i> <i>elements to be duplicated</i> VDUP;OFF
VDUP	The Vertical Duplication command; enter VDUP .
<i>dup#</i>	Specifies number of times the entered form element(s) will repeat vertically. Enter a value ranging from 1 through 512.
<i>offset#</i>	Specifies the vertical offset to establish the vertical spacing between each duplication of the form element(s) specified in the body of the command. Enter a value in terms of dot or character columns based on the Scale command (page 83), or use the CP.DP format (page 26). The offset is from starting row to starting row.
VDUP;OFF	Terminates the Vertical Duplication command; enter VDUP;OFF . If not entered, the IGP expects another form element to be defined for duplication. A single VDUP command can define different types of elements for duplication.

Example The following example is a vertical duplication of one horizontal line. The line is duplicated three times. To illustrate positioning, the starting row and column are indicated on the example but do not necessarily reflect actual location on the page.

```
VDUP;3;2      (3 duplications with 2-char. row spacing)
HORZ         (Command to be duplicated vertically)
1;52;15;65
STOP        (Terminates the duplicated element command)
VDUP;OFF    (Terminates the vertical duplication)
```

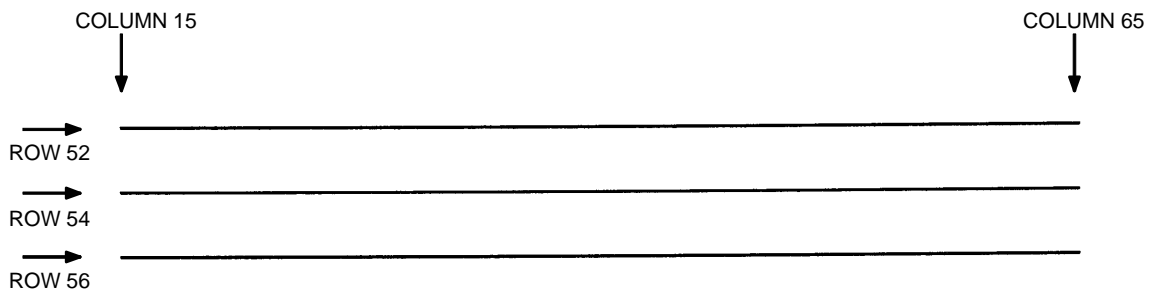

Emulation Switching

- Purpose** To switch the active emulation from PGL to the emulation selected.
- Mode** NORMAL
- Format** (cc)EMULATION; *emulation*
EMULATION The Emulation Switch command.
emulation Specifies the emulation to activate. Currently, the only selection is VGL (Code V). Enter **VGL**. If VGL is not the selection, this command is then ignored.
- Comments** This command is only processed when VGL is included in the software package. If not, this command is simply ignored. The switching of emulations causes PGL to perform a soft reset. Therefore, front panel selections return to their saved state, and all forms and logos resident in RAM memory are deleted.

End

- Purpose** Terminates the current mode of operation and must be used before entering a new mode command (EXECUTE, LOGO, NORMAL, or even CREATE).
- Mode** CREATE
- Format** END
- Comments** After the End command is received, the IGP flushes program errors, stores the error-free portions of the form program just completed, and then returns to the Normal mode. If the debug slash (/) is included in the Create command, the program prints with any corresponding error messages.

Execute Form Mode

How to Use the Execute Command

Forms are printed in the Execute Form mode. In addition to printing the form in the Execute Form mode, variable data can also be entered onto the form “dynamically” during the Execute Form mode. This dynamic data input during the Execute Form mode includes page numbers, alphanumeric data fields, and bar code data fields. Pagination, described on page 78, is performed in the Execute Form mode. Dynamic alphanumeric and bar code data require additional commands within the Execute Form mode.

The fastest method for repeated forms printing is to use the form feed character. Rather than sending a series of Execute/Normal commands, which slows the process by performing an *open-print-close* form sequence, the form feed character instructs the IGP to start a new page with new EVFU, dynamic and overlay data using the existing Execute commands for the form. The *EVFU Data-Dynamic Data-Overlay Data-Form Feed Character* sequence can be repeated indefinitely while maintaining the optimum print speed within the original Execute command.

Note

When a form count is not specified, a single line spacing (or a line containing overlay data) must always separate an EXECUTE command from a NORMAL command.

To Execute Forms Rapidly

In order to save reloading time, the IGP remembers the last form executed. However, a form must be loaded if it was not the last form executed, if it was used with a CREATE command since the last EXECUTE, or if any logo has been created.

When the form is found in memory, it is loaded and execution resumes; otherwise, the “FORM NOT FOUND” error is printed.

Print Formats in the Execute Form Mode

The Execute Form mode has two print formats. The *standard* execute command format, shown on the next page, is used for executing nonincremental data and incremental fixed data. An *incremental* execute command format, containing two additional parameters, is used for executing incremental dynamic data and is discussed on page 65.

During the Execute Form mode, the IGP responds to regular print format commands such as 8 lpi, and elongated characters. Some commands can be used in other modes in addition to the Execute Form mode. For example, Compressed Print, Expanded Print, Execute, Ignore, Select Format, and Vertical Line Spacing, which are also Normal mode commands, can be used in the Execute or Create Form modes. The IGP alternate character set can also be used in the Execute Form mode.

Execute Form: General Format

Purpose	Prints forms created in the CREATE mode.
Mode	NORMAL
Format	(cc)EXECUTE ; <i>formname</i> [;PAGE <i>n</i>] [;FC] [;ICNT <i>n</i>] [;IRST <i>n</i>] [;DISK] [EVFU Data] [(cc)AF <i>n</i> ; (D)ASCII text(D)] [(cc)BF <i>n</i> ; (D)data(D)] [(cc)GF <i>n</i> ; (D)logoname(D)] [(cc)IAF <i>n</i> ; [idir] STEPMASK; [RPT <i>n</i> ;] [RST <i>n</i> ;](D)STARTDATA(D)] [(cc)IBF <i>n</i> ; [idir] STEPMASK; [RPT <i>n</i> ;] [RST <i>n</i> ;](D)STARTDATA(D)] [Overlay Data] [Form Feed character] (cc)NORMAL
(cc)	The Special Function Control Code.
EXECUTE	The Execute Form command; enter EXECUTE .
<i>formname</i>	Identifies a previously defined form by name. Enter the form name exactly as used when created.
PAGE <i>n</i>	The optional Pagination command; enter PAGE and replace <i>n</i> with the decimal number of the starting page in a sequence of multiple pages. The number may be eight digits long and range between 0 and 99999999. The next page after 99999999 is 0. Leave a blank space between the PAGE command and the <i>n</i> value. The page number will print on the form in the location defined by the Page Number command in the Create Form mode. If the location of the pagination field was not specified in the Create Form mode, the page field is printed in the upper left corner of the form.
FC	The optional form count parameter specifies the number of copies of the form to print. Enter the appropriate number. When the last page prints, the IGP returns to the Normal mode automatically.

Note

Do not use the form count parameter if dynamic data (AF*n* and BF*n* parameters), incremental data (ICNT or IRST parameters), overlay data, or EVFU data are used in the Execute command.

ICNT <i>n</i>	The optional incremental form count. Enter ICNT and the Incremental value as described in the Execute Incremental Dynamic Data command described on page 65.
IRST <i>n</i>	The optional incremental reset count parameter. Enter IRST and the reset value as described in the Execute Incremental Dynamic Data command described on page 65.

DISK Optional parameter that specifies to recall the form from the flash memory. Enter **DISK**.

EVFU Data Optional parameter to use the EVFU to overlay data onto the form. (“EVFU Data” is not part of the Execute command. It is shown in the command sequence to indicate that actual EVFU data can be entered following the Execute command.) Enter EVFU data as described in Appendix C and on page 61.

(cc)AFn;(D)ASCII text(D)

The Execute Dynamic Alphanumeric Data command. Enter the dynamic alphanumeric data during the Execute Form mode as described in “Execute Form: Dynamic Alphanumeric Data” on page 62.

(cc)BFn;(D)data(D)

The Execute Dynamic Bar Code Data command. Enter the dynamic bar code data during the Execute Form mode as described in “Execute Form: Dynamic Bar Code Data” on page 63.

(cc)GFn;(D)logoname(D)

The Execute Dynamic Logo Command. Enter the name of the logo during the Execute Form mode as described in “Execute Form: Dynamic Logo” on page 64.

(cc)IAFn;[idir] STEPMASK;[RPTn;] [RSTn;] (D)STARTDATA(D)

The Execute Incremental Dynamic Alphanumeric Data command. Supply the data as described on page 66.

(cc)IBFn; [idir] STEPMASK; [RPTn;] [RSTn;] (D)STARTDATA(D)

The Execute Incremental Dynamic Bar Code Data command. Supply the data as described on page 66.

Overlay Data Overlay data can be entered during the Execute Form mode. (The words “Overlay Data” are not part of the Execute command. They are shown in the command sequence to indicate that actual overlay data can be entered following the Execute command.) Refer to “Execute Form: Overlay Data” on page 67.

Form Feed Character

Optional command instructing the IGP to start a new page with new EVFU, dynamic, and overlay data using the existing Execute commands for the current form. Using this EVFU Data-Dynamic Data and Overlay Data-Form Feed Character sequence can be repeated indefinitely, while maintaining the optimum print speed, within the original Execute command.

(cc)NORMAL The Normal mode command. If the form count parameter was not used in the Execute command, enter the SFCC and **NORMAL** to return the IGP to the Normal mode. The Normal mode command is input following all other Execute commands to enter variable data. (Refer to the following sections.) Input a line terminator to leave a blank line before entering the Normal command.

Execute Form: Electronic Vertical Format Unit

Purpose Provides an efficient method of rapidly slewing paper.

Mode EXECUTE

Format See Appendix C.

Comments The Electronic Vertical Format Unit (EVFU) is processed as overlay data within the Execute Form mode. Detailed EVFU information is provided in Appendix C.

The EVFU must be loaded while in the Execute Form mode and immediately following the Execute command. After executing the form and returning to Normal mode, the EVFU information is automatically deleted from printer memory. To print the form again, re-send the EVFU command.

Several key points to operating the EVFU are listed below.

- Send EVFU commands immediately following the Execute command or the format form feeds.
- The EVFU can be unloaded by issuing an END LOAD command only.
- The number of lines slewed is dictated by the current line spacing (lpi) setting.
- In those circumstances where the EVFU is being used to control the forms length only, the IGP forms length parameter can be used in place of the EVFU.
- The maximum number of EVFU channels is 192.
- Changing the LPI unloads the EVFU.

Execute Form: Dynamic Alphanumeric Data

Purpose	Incorporates the dynamic alphanumeric data into a previously identified location on a form.
Mode	EXECUTE
Format	(cc)AF <i>n</i> ; (D)ASCII text(D)
(cc)	The Special Function Control Code.
AF <i>n</i>	Indicates a dynamic alphanumeric field (AF) and its data (<i>n</i>). Enter AF and replace <i>n</i> with the number of the data field corresponding to the number used to identify the field when it was defined with the Alphanumeric command in the Create Form mode.
(D)	The printable character identifying the start and finish of the alphanumeric data. Enter any printable character other than a slash (/), the SFCC, or a character used within the data. The same character must be used at both ends of the data field but will not be printed with the data.
ASCII text	The group of ASCII characters (the alphanumeric string) to print. Enter any of the standard ASCII printable characters (except the character used as delimiters described in the (D) parameter). The data appears on the form at the location identified by the value of <i>n</i> .

Note

Be sure to enter Dynamic Alphanumeric Data *after* the Execute command and/or EVFU data but before any Overlay Data. (See the general Execute command format on page 59.)

Comments The location for the dynamic alphanumeric data must have been previously identified using the AF*n*;L parameters of the alphanumerics command in the Create Form mode. Inputting individual commands enters the new data into the identified location each time the form is printed.

You can repeat the (cc)AF*n*;(D)ASCII text(D) sequence to complete as many data fields as you defined on the form in the Create Form mode. You can also combine the Execute Dynamic Bar Code Data command in the same Execute command sequence. Each “page” of dynamic data (the dynamic fields, data, and overlay data) for the form must be separated from the next page of new dynamic data by a form feed.

Execute Form: Dynamic Bar Code Data

Purpose	Incorporates the dynamic bar code data into a previously identified location on a form.
Mode	EXECUTE
Format	(cc)BF <i>n</i> ; (D) <i>data field</i> (D)
	(cc) The Special Function Control Code.
	BF <i>n</i> Indicates a dynamic bar code field (BF) and its data (<i>n</i>). Enter BF and replace <i>n</i> with the number of the data field corresponding to the number used to identify the field when it was defined with the bar code command during the Create Form mode.
	(D) The printable character (quotation marks for example) identifying the start and finish of the bar code data. Enter any printable character other than a slash (/), the SFCC, or a character used within the data. The same character must be used at both ends of the data field but will not be printed.
	<i>data field</i> Enter the characters for the bar code data. The character types allowed in the data varies with the bar code type. Refer to the data field descriptions for the selected bar code types. The data appears on the form at the location identified by <i>n</i> .

Note

Be sure to enter Dynamic Bar Code Data *after* the Execute command and/or EVFU data but before any Overlay Data. (See the general Execute command format on page 59.)

Comments The bar code location must have been previously identified using the BF*n*;L or BF*n* parameters of a bar code command in the Create Form mode. Use the appropriate bar code command to enter the bar code data in that location. Inputting individual commands enters new bar code data into the identified location each time the form is printed. You can repeat the (cc)BF*n*; (D)*data field*(D) sequence to complete as many bar code data fields as were defined on the form in the Create Form mode. You can also combine the Execute Dynamic Alphanumeric Data command in the same Execute command sequence. Each “page” of dynamic data (the dynamic fields, data, and overlay data) for the form must be separated from the next page of new dynamic data by a form feed.

Execute Form: Dynamic Logo

Purpose Incorporates the dynamic graphic logo into a previously identified location of a form.

Mode EXECUTE

Format (cc)GF*n*;(D)logoname(D)

(cc) The Special Function Control Code.

GF*n* Indicates the dynamic logo field. Enter **GF** and replace *n* with the number of the field corresponding to when it was defined with the Logo Call command during the CREATE form mode.

(D) The printable character identifying the start and finish of the logo name. Enter any printable character other than a slash (/), the SFCC, or a character used within the name. The same character must be used at both ends of the data field but will not be included in the logo name.

logoname Enter the logo name. If the logo is not found in DRAM, the flash memory is searched.

Comments The logo location must have been previously identified using the GF*n* parameters of a logo call command in the Create Form mode. Then use the appropriate logo command to enter the logo data in that location. Inputting individual commands enters new logo data into the identified location each time the form is printed.

You can repeat the (cc)GF*n*;(D)logoname(D) sequence to complete as many logo fields as were defined on the form in the Create Form mode. You can also combine the Execute Dynamic Alphanumeric Data command in the same Execute command sequence. Each "page" of dynamic data (the dynamic fields, data, and overlay data) for the form must be separated from the next page of new dynamic data by a form feed.

NOTE: There are no incremental logos.

Execute Form: Incremental Dynamic Data

Purpose Incorporates incremental/decremental capability to dynamic alphanumeric or bar code data supplied as a part of the Execute Form mode.

Mode NORMAL



Note In the command below, incremental execute parameters are shown in **boldface** type; standard execute command parameters are shown in *italics*. The general execute format is shown on page 59.

Format *(cc)EXECUTE; formname [;PAGE n] [;FC] [;**ICNT**n] [;**IRST**n]*

ICNT*n* Identifies the incremental form count to specify the number of forms to generate with the incremental fields automatically updated. Enter **ICNT** and replace *n* with a value ranging from 1 through 65,535 to specify the number of forms.

IRST*n* The optional incremental reset count parameter to specify the number of forms to generate before resetting all incremental fields to their starting values. The reset count parameter is useful in dividing the total number of forms generated into multiple groups of identical copies. To use this parameter, enter **IRST** and replace *n* with a value ranging from 1 through 65,535 to specify the reset count (how many forms generated before resetting the incremental fields). If the reset count value is equal to or greater than the incremental count value, the reset will never occur.

Example The following forms were generated from **ICNT6, IRST2**. (To duplicate incremental fields within a form, refer to page 40.)

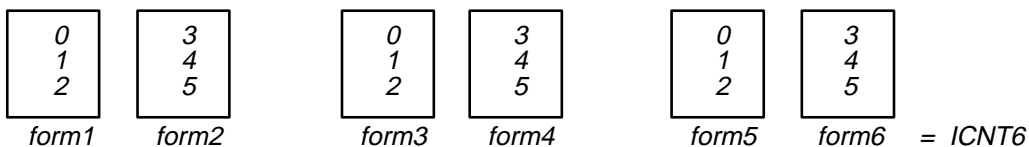

Supplying Dynamic Data for Incremental Fields

Incremental dynamic data fields are created in the Create Form mode using the incremental alphanumeric or bar code commands. The incremental dynamic data itself is supplied during the Execute Form mode at the top of the form prior to any overlay data. The incremental dynamic data (either alphanumeric or bar code data) can be changed with each new batch of forms. Incremental dynamic data fields specified in the Create Form mode will not appear on the form if corresponding incremental dynamic data is not supplied in the Execute Form mode.

Format	For incremental dynamic alphanumeric data: (cc)IAF <i>n</i> ; [<i>idir</i>] STEPMASK; [RPT <i>n</i> ;] [RST <i>n</i> ;] (D)STARTDATA(D)
	For incremental dynamic bar code data: (cc)IBF <i>n</i> ; [<i>idir</i>] STEPMASK; [RPT <i>n</i> ;] [RST <i>n</i> ;] (D)STARTDATA(D)
(cc)	The Special Function Control Code.
IAF	Identifies the command as an incremental alphanumeric dynamic data; enter IAF .
IBF	Identifies the command as an incremental bar code dynamic data; enter IBF .
<i>n</i>	Identifies the field number of the dynamic data field as entered in the Create Form mode. Replace <i>n</i> with the number used to identify the field when it was defined.
<i>idir</i>	The optional increment direction parameter to specify an increase or decrease of the data. Enter a plus sign (+) or leave the field blank to increment (the default). Enter a minus sign (-) to decrement.
STEPMASK	Defines the increment amount (step), the number of character positions in the data field, and provides a mask to control the increment function on specific parts of the data. Refer to "Incremental Bar Code Fields" on page 208 or "Alphanumerics, Incremental Fields" on page 34 for complete information on STEPMASK parameter values.
RPT <i>n</i>	The optional incremental repeat count parameter to specify the number of times a particular field value is repeated before it is incremented. A repeated field value is useful when printing multiple rows/columns of identical labels before incrementing to the next value. To use the repeat count parameter, enter RPT and replace <i>n</i> with a numeric value ranging from 1 through 65,535 to specify the repeat count. The default repeat count parameter is 1, which will increment the field value each time it is printed.

RST n The optional incremental reset count parameter to specify the number of times an incremented field is printed (on one or more forms) before it is reset to the starting value. A reset count is useful when printing a hierarchy of fields where a low-level field generates a sequence of numbers, is reset, and the next higher field level is incremented (such as in a unit/box/carton application). To use the reset count parameter, enter **RST** and replace n with a number ranging from 1 through 65,535 to specify the reset count. The default reset count value is 0.

STARTDATA Defines the starting value of the incrementing field. The maximum amount of STARTDATA characters must be equal to or less than the number of characters in the STEPMASK field. If the number of data characters in the Dynamic Alphanumeric Data command is less than the number used in STEPMASK, the data will print right justified with preceding spaces. (Leading spaces are not provided for bar code data.) For dynamic bar code data, the type of characters allowed for incrementing fields is based on the type of bar code. Refer to the individual bar code descriptions in the "Bar Codes" chapter for information on valid type and quantity of data characters. The STARTDATA must be enclosed within standard printable character delimiters just as a standard data field is enclosed within delimiters.

Execute Form: Overlay Data

Overlay data is variable alphanumeric data entered onto a predefined form. The form is completed by positioning the data in the exact location it will appear on the form when printed. The data is placed horizontally using tabs and spaces, and vertically using line feeds, form feeds, and the Electronic Vertical Format Unit (EVFU).

For example, if the serial number field on the form begins at character row 22 and column 14, enter 22 line feeds, space over 14 columns, and input serial number overlay data. An entire form can be completed with a page of overlay data in this manner. Overlay data at the end of a form is printed on a new form until all overlay data is used. Then, to advance to the next form, use a form feed.

The IGP EVFU can be used to control vertical spacing of the overlay data. In place of line feed commands input individually, the EVFU can be programmed (during the Execute Form mode) to slew the overlay data to the predetermined line with a single command.

Expanded Print

Purpose	Selects font sizes other than the default font.
Mode	NORMAL, EXECUTE
Format	(cc)EXPAND; <i>VE</i> ; <i>HE</i>
(cc)	The Special Function Control Code.
EXPAND	The Expanded Print command; enter EXPAND .
<i>VE</i>	Specifies the vertical expansion factor; enter a value ranging from 0 through 113.
<i>HE</i>	Specifies the horizontal expansion factor; enter a value ranging from 0 through 113. Both <i>VE</i> and <i>HE</i> parameters must be zero or non-zero. If one expansion value is 0, they must both be 0. A <i>VE</i> or <i>HE</i> setting of 1 expands the appropriate plane but produces single-size characters. A <i>VE</i> and <i>HE</i> setting of 0 produces standard-size characters.

Comments The Expanded Print command uses the 0.10-inch, 10 cpi Gothic typeface as the default base value from which alphanumeric characters are expanded.

The character height can be up to a maximum of 11.3 inches, which means if a page is 11.3 inches high, you can print a character that fills the entire height of the page.

After an Expanded Print command is entered, all subsequent alphanumerics print at the specified expansion until another Expanded Print command, a Normal Mode command, or a Reset command is entered. An Expanded Print command with *VE* and *HE* set to 0 selects standard character printing.

Example The following command results in character printing at 25 times its vertical size and 40 times its horizontal size.

```
~EXPAND;25;40
```

Font

Purpose	Selects typefaces other than the default Gothic font.
Mode	NORMAL, CREATE, EXECUTE
Format	(cc)FONT [;FACE #] [;BOLD #] [;SLANT #] [;SYMSET #] [;POINT #] [;SPACE #]



Note The font is activated according to the changed options upon receipt of the font command.

(cc)	The Special Function Control Code. (If you are using the Font command in the CREATE mode, <i>do not</i> enter the SFCC.)
FONT	The Font command; enter FONT .
FACE #	Identifies the specific typeface. This option is ignored for line matrix printers.
BOLD #	Selects a bold attribute. Enter BOLD , a space, and ON or 1 to turn bold on, or OFF or 0 for no bold attribute.
SLANT #	Selects a slanting factor. (Slant is similar to italic, but also offers a backward slant.) Enter SLANT , a space, and RIGHT or 1 for a typical italic slant, LEFT or -1 for a backward slant, or OFF or 0 for no slant attribute.
SYMSET #	Selects a font symbol set other than the default ASCII symbol set. Enter SYMSET , a space, and a value representing the symbol set as identified in Table 21 on page 251.
POINT #	Selects the point size for the current typeface. Enter POINT , a space, and a point size ranging from 4 through 999. Point sizes are available in quarter-point increments. Horizontal pitch is automatically adjusted based on the point size selected. The point parameter cannot be used when in CREATE mode. Use the point parameter of the ALPHA command.
SPACE #	Selects a spacing alignment scheme, where applicable. Enter SPACE , a space, followed by a value 0 through 3.

Comments Font parameters in Normal and Execute modes do not affect the fonts that have already been established and saved on a form.

Font commands issued in the Create mode affect only the current form being created and not any of the fonts on other forms or for Execute or Normal mode text.

You can use any or all Font parameters, listed in any order, in a single Font command. (Do not list font parameters on separate lines.) Parameters and symbol sets not specified retain the previously selected value. Parameters incorrectly specified retain the previously selected value.

All Font command parameters are reset to default values upon receiving a NORMAL, RESET, CONFIG;RESET, or new CREATE command. Multiple font commands within a single form will save the *last* font command parameters specified. Symbol sets can also be selected using the ISET or USET commands. (Refer to Chapter 5.)

To change font width and height, use the Compressed Print (Density) or Expanded Print commands described on pages 47 and 72, respectively.

Example The following command prints the current font bolded with a right slant. This font will continue to print until another Font command, a Normal mode command, or a Reset command is entered.

```
~FONT;BOLD ON;SLANT RIGHT
```

Form Length

Purpose	Sets the length of the form to a specific number of lines at 6 or 8 lpi.
Mode	CREATE
Format	LFORM6; <i>n</i> or LFORM8; <i>n</i>
	LFORM6 The Form Length command for 6 lpi forms; enter LFORM6 .
	LFORM8 The Form Length command for 8 lpi forms; enter LFORM8 .
	<i>n</i> Specifies the form length in total number of lines allowed per form. The range depends on the paper size used. An error message will result if the maximum line values are exceeded.

Note



This command affects only printed text inside of IGP forms, not the printer lpi. The LFORM8 command considers a line as 9 dot rows; the LFORM6 command considers a line as 12 dot rows. The 9 and 12 dot rows per line matches the dot rows of the printer in the DP mode if set to 8 or 6 lpi, respectively.

Example The following example establishes a form length of 8 inches (48 lines at 6 lpi):

```
LFORM6 ; 48
```

Ignore Sequence

Purpose	Enables the IGP to ignore all characters after the Ignore Sequence On (IGON) command is entered. All characters are ignored until the Ignore Sequence Off (IGOFF) command is entered.
Mode	NORMAL, CREATE, or EXECUTE
Format	(cc)IGON or (cc)IGOFF

Note A line terminator is not required in the Ignore Sequence.



(cc)	The Special Function Control Code.
IGON	Ignore Sequence On command; enter IGON .
IGOFF	Exits Ignore Sequence; enter IGOFF .

Comments IGON and IGOFF can also be used anywhere in the data stream.

Line Spacing

Purpose	Defines the lines per inch (lpi) printing format.
Mode	NORMAL, EXECUTE
Format	(cc)LPI; <i>n</i>
(cc)	The Special Function Control Code.
LPI	The Vertical Line Spacing command; enter LPI .
<i>n</i>	Selects the line spacing in lpi; enter 6, 8, 9, or 10 .

Comments Standard line spacing is 6 lpi. After a Vertical Line Spacing command is entered, all subsequent alphanumerics print at the specified lpi until another Vertical Line Spacing command, a Normal Mode command, or a Reset command is entered.

Example The following command selects 9 lpi printing format until another Line Spacing command, a Normal Mode command, or a Reset command is entered.

```
~LPI;9
```

Lines, Horizontal

Purpose	Defines horizontal lines.
Mode	CREATE
Format	HORZ <i>LT; R; SC; EC</i> STOP
HORZ	The Horizontal Line command; enter HORZ .
<i>LT</i>	Defines the line thickness, measured in 1/72-inch dots. Enter a value of 1 or greater. Horizontal line thickness expands downward from the given row.
<i>R</i>	Defines the row to draw the horizontal line. Enter a value ranging from row 1 through one less than the length of the form. Character row or dot row is specified based on the Scale command (page 83), or use the CP.DP format (page 26).
<i>SC</i>	Defines the starting column of the horizontal line. Enter a value ranging from column 1 through one less than the width of the form. Character column or dot column is specified based on the Scale command (page 83), or use the CP.DP format (page 26).
<i>EC</i>	Defines the ending column of the horizontal line. Enter a value ranging from column 2 through the last column of the form. The ending column must be greater than the starting column. Character column or dot column is specified based on the Scale command (page 83), or use the CP.DP format (page 26).
STOP	Stop indicates the end of the HORZ command; enter STOP . If not entered, the IGP expects another set of Horizontal Line command parameters.

Example The following example specifies 2 horizontal lines. The first line uses the character row in the R parameter, and the second line uses CP.DP format. To illustrate positioning, the starting row and column are indicated on the example but do not necessarily reflect actual location on the page.

```
HORZ
1;60;15;65
1;60.5;15;65
STOP
```

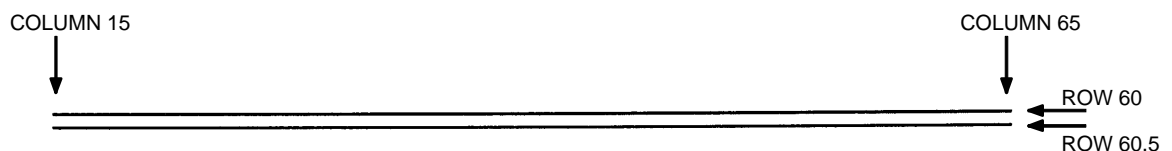

Lines, Vertical

Purpose	Defines vertical lines.
Mode	CREATE
Format	VERT <i>LT; C; SR; ER</i> STOP
VERT	The Vertical Line command; enter VERT .
<i>LT</i>	Defines the line thickness, measured in 1/60-inch dots. Enter a value of 1 or greater. Vertical line thickness expands to the right from the starting column.
<i>C</i>	Defines the column where the vertical line begins. Enter a value ranging from column 1 through one less than the width of the form. Character column or dot column is specified based on the Scale command (page 83), or use the CP.DP format (page 26).
<i>SR</i>	Defines the starting row of the vertical line. Enter a value ranging from row 1 through one less than the length of the form. Character row or dot row is specified based on the Scale command (page 83), or use the CP.DP format (page 26).
<i>ER</i>	Defines the ending row of the vertical line. Enter a value ranging from row 2 through the last row of the form. The ending row must be greater than the starting row. Character row or dot row is specified based on the Scale command (page 83), or use the CP.DP format (page 26).
STOP	Stop indicates the end of the VERT command; enter STOP . If not entered, the IGP expects another set of Vertical Line command parameters.
Example	The following program specifies 4 vertical lines. To illustrate positioning, the starting row and column are indicated on the example but do not necessarily reflect actual location on the page.

```

VERT
2;36;53;61
2;50;53;61
2;60;53;61
2;70;53;61
STOP
    
```

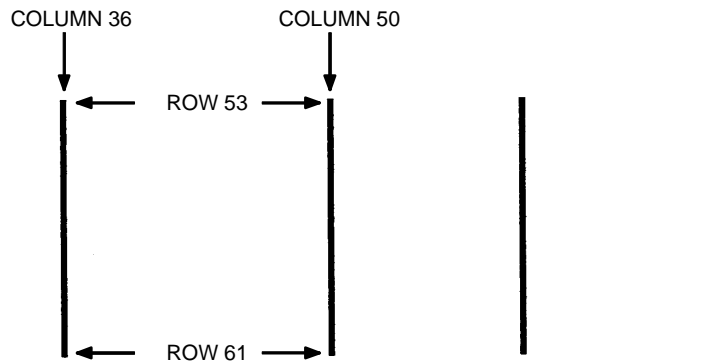

Listen

Purpose Disables the IGP from the quiet state and enables the IGP for standard operation. (The Quiet command is explained on page 81.)

Mode NORMAL

Format (cc)LISTEN

(cc) The Special Function Control Code.
 LISTEN The Listen command; enter **LISTEN**.



Note When the IGP is in the quiet state, P-Series line printer emulation commands are active. Refer to your *LinePrinter Plus[®] Programming Reference Manual* for descriptions of these commands.

Logo Call

Purpose Selects and positions a previously defined logo. (The logo itself is actually defined separately in the Create Logo mode.) The logo is defined using IGP dots.

Mode CREATE

Format LOGO
 SR; SC; logoname [:DISK]
 STOP

LOGO The Logo Call command; enter **LOGO**.

<i>SR</i>	Defines the starting row of the logo. The <i>SR</i> (and <i>SC</i>) parameter specifies the location for the logo based on the upper left corner of the grid in which the logo was defined. Enter a value ranging from row 1 through one less than the length of the form. Character row or dot row is specified based on the Scale command (page 83), or use the CP.DP format (page 26).
<i>SC</i>	Defines the starting column of the logo. The <i>SC</i> (and <i>SR</i>) parameter specifies the location for the logo based on the upper left corner of the grid in which the logo was defined. Enter a value ranging from column 1 through one less than the width of the form. Character column or dot column is specified based on the Scale command (page 83), or use the CP.DP format (page 26).
<i>logoname</i>	Identifies a previously defined logo by name for use on the form. Enter the logo name exactly as used to define and store the logo.
DISK	Optional parameter to retrieve logo from the flash memory. Enter DISK .
STOP	Stop indicates the end of the LOGO command; enter STOP , and the IGP will wait for a new command. If not entered, the IGP expects another set of Logo Call command parameters.

Example The following sample program specifies three logo calls placing the same logo at three different locations. (The logo was previously defined and stored.) The starting row and column specify the upper left corner of the grid in which the logo was defined. To illustrate positioning, the starting row and column are indicated on the example but do not necessarily reflect actual location on the page.

```
LOGO
56 ; 35 ; HAND
56 ; 50 ; HAND
56 ; 65 ; HAND
STOP
```

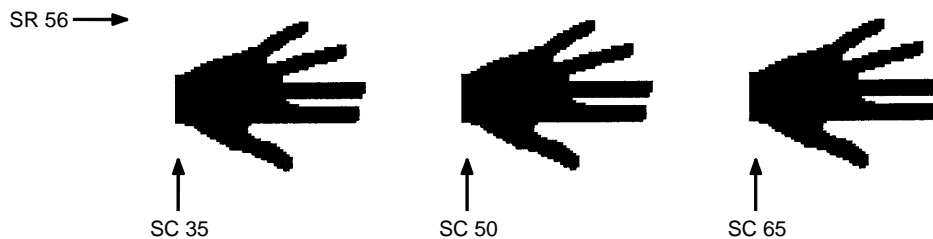

Note



When the logo to be executed is not found in memory, the "LOGO NOT FOUND" error is printed.

Logo Mode, Create

Purpose	Places the IGP in the Create Logo mode, where logos can be defined using the appropriate dot placements.
Mode	NORMAL
Format	(cc)LOGO; <i>logoname</i> ; <i>VL</i> ; <i>HL</i> [; <i>DISK</i>] <i>row#</i> ; <i>dot</i> ; <i>dot1-dot2</i> ; <i>dot</i> END
(cc)	The Special Function Control Code.
LOGO	The Logo command; enter LOGO .
<i>logoname</i>	Enter a maximum of 15 alphanumeric characters for the name of the logo. (Refer to page 24 for a list of allowable Logo Name characters.) All future references to this logo (Delete Logo or Logo Call commands) must use this name. If a logo is defined with the same name as a logo already existing in memory, the newly defined logo will replace the existing logo.
<i>VL</i>	Defines the vertical length of the logo grid in dot rows; enter a value sufficient for the vertical size of the logo, not exceeding 252. The dot rows are vertically spaced 1/72-inch apart.
<i>HL</i>	Defines the horizontal length of the logo grid in dot columns; enter a value sufficient for the horizontal size of the logo, not exceeding 240. On each row, the dots are horizontally spaced 1/60-inch apart.
DISK	Optional parameter to store the logo on the flash memory. Enter DISK .
<i>row#</i>	Identifies the row number for each row of dots in the logo. Enter each row number on a separate command line. Rows are numbered sequentially from top to bottom.
<i>dot</i>	Identifies a single dot position in the row. Enter each dot number used. Dots are numbered sequentially from left to right.
<i>dot1-dot2</i>	Identifies a series of dot positions within the row, including dot1 on the left end and dot2 on the right end. Enter the series of dot rows. Series of dot rows can be combined with single dot positions in the same command line.
END	Terminates the Create Logo mode; enter END .

Comments The logo is defined by specifying the overall size and the rows of data used. The actual number of logos you can create and store depends on the memory required for each logo.

The maximum logo size allowed is 252 rows high (3.5 inches) and 240 columns wide (4 inches). Values exceeding either of these dimensions will produce an error. To maximize memory space, do not define the vertical and horizontal length of the logo grid larger than is required to capture the design. The printer produces a grid with 72 dots per inch vertically and 60 dots per inch horizontally. Consequently, a logo must be designed using this scale.

The Logo Call command (page 74) in the Create Form mode brings the predefined logo into a form. The starting row and column parameters refer to the upper left corner of the logo grid. Once created, the logo is ready to be used in any form and will print at the size shown.

```

~LOGO;TAPEHOLD;36;40
1;12-18
2;10-20
3;9-22
4;8-24
5;7-25
6;6-26
7;5-26
8;4-25
9;4-25
10;3-24
11;3-24
12;2-23
13;2-23
14;2-14;17-23
15;1-12;19-22;38-39
16;1-12;20-23;37-40
17;1-11;20-23;37-40
18;1-11;20-23;36-40
19;1-11;20-23;36-40
20;1-11;20-23;35-40
21;1-12;20-24;35-40
22;1-12;19-24;34-39
23;1-14;17-25;33-39
24;1-28;31-39
25;1-39
26;2-38
27;2-38
28;2-37
29;3-37
30;3-36
31;3-36
32;4-35
33;5-34
34;6-33
35;7-32
36;9-30
END

```

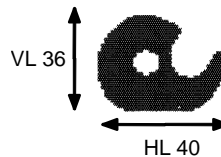

Normal Mode

Purpose Places the IGP in the Normal mode of operation, where the data stream is not changed but monitored for a Special Function Control Code followed by an IGP command.

Mode NORMAL, EXECUTE

Format (cc)NORMAL

(cc) The Special Function Control Code.

NORMAL The Normal mode command; enter **NORMAL**.

Comments Normal mode is entered automatically when the printer is powered on with IGP. In Normal mode, the IGP uses the default font and line spacing values.

A blank line or overlay data must always separate an EXECUTE command from a NORMAL command, unless a form count is given for the EXECUTE.

Page Number

Purpose Defines where a page number is placed on a form and automatically increases the page number on each page.

Mode CREATE

Format PAGE; SR; SC

PAGE The Page Number command; enter **PAGE**.

SR Defines the starting row of the page number. Enter a value ranging from row 1 through one less than the length of the form. Character row or dot row is specified based on the Scale command (page 83), or use the CP.DP format (page 26).

SC Defines the starting column of the page number. Enter a value ranging from column 1 through one less than the width of the form. Character column or dot column is specified based on the Scale command (page 83), or use the CP.DP format (page 26).

If the SR or SC extends beyond the page boundaries, an Error 76 will occur in the Execute Form mode, and default page number SR SC values are used.

Comments To begin automatically incrementing the page numbers, the starting page number must be specified during the Execute command.

Example The following command places the page numbers at row 60 column 70 on the form.

```
PAGE;60;70
```

Paper

Purpose	Controls printer paper options.
Mode	NORMAL, EXECUTE
Format	(cc)PAPER [; <i>option</i>]
	(cc) The Special Function Control Code.
	PAPER The PAPER command; enter PAPER .
	EJECT Prints all pages that are in the buffer. Enter EJECT . This is currently the only PAPER command available for line matrix printers.

Paper Instruction - Data Bit 8

Purpose	Enables or disables data bit 8 as the paper instruction signal when the IGP is configured for a serial interface. (This command has no effect on a parallel interface.)
Mode	NORMAL
Format	(cc)PION or (cc)PIOFF
	(cc) The Special Function Control Code.
	PION The Data Bit 8 Paper Instruction On command; enter PION . When this command is sent, 7 data bits are allowed; data bit 8 is enabled as the paper instruction. When data bit 8 is set high, the PION command slews paper. When data bit 8 is set low, the PION command prints data characters.
	PIOFF The Data Bit 8 Paper Instruction Off command; enter PIOFF . When this command is sent, 8 data bits are allowed for character data because data bit 8 is disabled as the paper instruction. Subsequent occurrences of data bit 8 in the data stream cause printing from the extended character set.

Paper Instruction (PI) Enable/Disable

Purpose Enables or disables use of the PI line using a parallel I/O device. (This command does not enable/disable PI line sensing; it enables or disables use of the “sensed” PI line.)

Mode NORMAL

Format (cc)EN-PI or (cc)DIS-PI

(cc) The Special Function Control Code.

EN-PI The Enable PI command; enter **EN-PI**. When this command is enabled, the IGP senses PI line, the 8 bits of data are interpreted as a paper instruction command, and the PI line itself is ignored.

DIS-PI The Disable PI command; enter **DIS-PI**. When the Disable PI command is sent, the 8 bits of data are interpreted as printable characters, and not as a paper instruction command.

Print File

Purpose Prints files from the flash memory. Print File can be used to show the SETUP functions that exist.

Mode NORMAL

Format (cc)PRINT; *filename*

(cc) The Special Function Control Code.

PRINT The Print File command; enter **PRINT**.

filename The filename to be printed.

Comments Do not use wildcard characters because the Print File command will attempt to print any file on the flash.

Example Example of how to print setup.ptx:

```
~PRINT; SETUP.PTX
```

Quiet

- Purpose** Places the IGP in the Quiet mode, where all data passed to the ASCII emulation is unaffected by IGP commands except for the LISTEN, SFON/SFOFF, and IGON/IGOFF.
- Mode** NORMAL
- Format** (cc)QUIET
- (cc) The Special Function Control Code.
- QUIET The Quiet command; enter **QUIET**. The IGP remains in the quiet state until the Listen command is received.
- Comments** In the Quiet mode IGP ignores all commands except LISTEN, SFON/SFOFF, and IGON/IGOFF. All commands for the currently selected protocol in the ASCII emulation will be interpreted.
- The IGP remains quiet until the LISTEN command (page 74) enables standard IGP operation. The Quiet command is ignored if the IGP is in the Execute Form mode.

Recall

- Purpose** Loads the user pre-stored program setup file, setup.ptx, from flash memory into the printer. This is done without sending a system reset.
- Mode** NORMAL
- Format** (cc)RECALL
- Comments** The file setup.ptx is also automatically recalled into the printer upon a RESET command.

Reset

Purpose Deletes all forms and logos from IGP memory. The Reset performs the following tasks:

- Prints any objects in the current page
- Deletes all forms and logos resident in memory
- Sets the font to the default Gothic 12 point/10CPI
- Releases all user defined character mappings
- Runs the SETUP.PTX file if present

Mode NORMAL or EXECUTE

Format (cc)RESET

(cc) The Special Function Control Code.
RESET The Reset command; enter **RESET**.

Reverse Print

Purpose Defines an area of the form where form elements are reverse printed (white on black).

Mode CREATE

Format REVERSE
[DARK;] *SR*; *SC*; *ER*; *EC*
STOP

REVERSE The Reverse Printing command; enter **REVERSE**.

DARK Optional parameter to select a denser black background. Enter **DARK**, or **D**, to select the denser background. More information about dark printing is provided on page 28.

SR Defines the starting row of the reverse print field. Enter a value ranging from row 1 through one less than the length of the form. Character row or dot row is specified based on the Scale command (page 83), or use the CP.DP format (page 26).

SC Defines the starting column of the reverse print field. Enter a value ranging from column 1 through one less than the width of the form. Character column or dot column is specified based on the Scale command (page 83), or use the CP.DP format (page 26).

ER Defines the ending row of the reverse print field. Enter a value ranging from row 2 through the last row of the form. Character row or dot row is specified based on the Scale command (page 83), or use the CP.DP format (page 26).

	If the ending row is less than the starting row, the rows are automatically switched. The same is done with the ending and starting column.
<i>EC</i>	Defines the ending column of the reverse print field. Enter a value ranging from column 2 through the last column of the form. The ending column must be greater than the starting column. Character column or dot column is specified based on the Scale command (page 83), or use the CP.DP format (page 26).
STOP	Stop indicates the end of the REVERSE command; enter STOP , and the IGP will wait for a new command. If not entered, the IGP will expect another set of Reverse Print command parameters.

Comments You can use reverse print with all form elements (alpha, lines, boxes, etc.). The IGP can also reverse print bar codes, but reverse printed bar codes are unreadable by scanning devices.

Scale

Purpose	Defines the vertical line spacing and the horizontal pitch of the form for data positioning specified by character row and column or dot row and column.
Mode	CREATE
Format	SCALE; DOT [<i>;horz;vert</i>] or SCALE; CHAR [<i>;lpi</i>] [<i>;cpi</i>]
	SCALE The Scale command; enter SCALE .
	DOT Specifies the dot scale. Enter DOT .
	<i>horz/vert</i> Gives resolution for the dot parameter. Default is 60 dpi (horizontal) by 72 dpi (vertical).
	CHAR Specifies the character scale. Enter CHAR .
	<i>lpi</i> The optional vertical line spacing parameter (in lines per inch) for character scaling. Enter 6, 8, 9 , or 10 . The default is 6 lpi.
	<i>cpi</i> The optional horizontal pitch parameter (in characters per inch) for character scaling. Enter 10, 12, 13, 15, 17 , or 20 . The default is 10 cpi.

Comments If the character scale is selected, starting row/column or ending row/column parameters are specified by character row and column. The lines per inch (lpi) value for a character scale form can be 6, 8, 9, or 10. Characters per inch (cpi) can be either 10, 12, 13, 15, 17, or 20. For example, on a printer with a maximum print width of 80 columns, an 8-1/2 x 11-inch form at the 6 lpi 10 cpi default has 66 rows and 80 columns in the character scale. (Refer to your printer *User's Guide* to determine your maximum print boundaries.)

If the dot scale is selected, the parameters are specified in dot row and column. For example, based on a 60 dpi horizontal and 72 dpi vertical dot scale, a form of 8-1/2 x 11 inches has 792 rows (72 dpi x 11 inches) and 510 columns (60 dpi x 8-1/2 inches), and a form of 8 x 11 inches has 792 rows and 480 columns.

The default scale factor uses character row and column (6 lpi and 10 cpi). Anytime CP.DP format (page 26) is used, the scale assumes 6 lpi and 10 cpi and a 60 x 72 dpi format.

You can change the scale at any time during forms creation by using either of the Scale commands. Elements designed before the scale change will print at the former scale, while those elements following the scale change will print at the current scale.

Note

For alphanumeric data, the Scale command only affects data position. For graphic elements (such as lines and boxes), the Scale command can also affect line thickness if the horizontal/vertical scales are given.

Select Format

Purpose Enables the IGP to ignore all host-generated paper movement commands (00-0F hex).

Mode NORMAL, CREATE or EXECUTE

Format (cc)SFON or (cc)SFOFF

Note

A line terminator is not required in the Select Format Sequence.

(cc)	The Special Function Control Code.
SFON	The Select Format On command. Enter SFON .
SFOFF	Exits Select Format. Enter SFOFF .

Comments During Select Format, you may enter the following IGP paper movement commands. All the commands must be entered in UPPERCASE. These commands can only be used with the Select Format command. If used at any other time, an error condition may result.

Command Paper Movement Function

(cc)CR	Sends a carriage return (hex 0D)
(cc)LF	Sends a line feed (hex 0A)
(cc)FF	Sends a form feed (hex 0C)

Although the Select Format command enables the IGP to ignore all host-generated paper movement commands, you can input IGP paper movement commands with Select Format on.

SFON/SFOFF cannot be used during Ignore Sequence (page 71).

Setup

Purpose Automatically executes and loads IGP/PGL commands such as forms, logos, customized print environments, etc., from flash memory to the printer whenever printer power is applied or when the RESET command (page 82) is sent.

Mode NORMAL

Format (cc)SETUP
HOST DATA
(cc)SETUPEND

(cc) The Special Function Control Code.

SETUP The Setup command; enter **SETUP**.

HOST DATA Any IGP/PGL commands, form definitions, text, etc. to be stored and executed at power-up.

SETUPEND Finishes storing host data and returns the printer to the NORMAL mode. Enter **SETUPEND**.

Comments Because the RESET command causes the setup routine to be executed, the RESET command can not be in the SETUP information or else an infinite loop will occur.

If IGP/PGL commands have not been added between the SETUP and SETUPEND commands, the SETUP.PTX file on the flash memory is automatically deleted, and no IGP/PGL SETUP commands are executed upon printer power-up.

Note



The SETUP.PTX is automatically created by the IGP/PGL when the ~SETUPEND command is received. When the SETUP.PTX file is not on the flash memory, no extra IGP/PGL commands are performed on power up.

Special Function Control Code Change

Purpose	Changes the current Special Function Control Code (SFCC).
Mode	NORMAL or EXECUTE
Format	(cc)SFCC; <i>n</i> or (cc)SFCC; ' <i>n</i> '
(cc)	The current Special Function Control Code.
SFCC;	Specifies the Special Function Control Code change command. Enter SFCC ; (the semicolon is required.)
<i>n</i>	Represents the ASCII decimal numeric value for the new SFCC. Replace <i>n</i> with a decimal value between 0 and 255.
' <i>n</i> '	Represents the hexadecimal value for a printable character as the new SFCC. Replace ' <i>n</i> ' with a hexadecimal value between 20 and 7F. If representing the new SFCC in hexadecimal, it must be enclosed in single quotes.

Comments When the SFCC is changed using the SFCC command, the change is effective immediately and the old SFCC is no longer recognized.

When printer power is turned off and on, the SFCC returns to the configuration default. The configuration default SFCC can also be re-selected by sending the command: (cc)**SFCC**;

Example The following example, using both the ASCII and hexadecimal values, changes the SFCC from the tilde (~) to the caret (^).

```
~SFCC;94 or ~SFCC;'5E'
```

3

Bar Codes

Overview

A bar code is a graphic representation of alphanumeric characters. Bar codes are produced by entering bar code commands in the Create Form mode. The IGP bar codes are listed in Table 7, with detailed bar code information provided on the referenced pages. All parameters must be separated by a semicolon (;) unless noted otherwise. Throughout this chapter, actual commands required for input are shown exactly as they must be entered, while all parameters associated with that command are shown in italics. Optional parameters are enclosed in brackets. Spaces are used only to visually separate the command parameters, but do not enter these spaces in your command.

Table 7. Available Bar Codes

Bar Code	Mnemonic	Symbol Length	Code Set	Page No
Codabar	CODABAR	Variable	Alphanumeric	91
Code 39	C3/9	Variable	Alphanumeric	96
Code 93	CODE93	Variable	Alphanumeric	102
Code 128 - A, B and C	C128A C128B C128C	Variable	Alphanumeric and Control Codes	108
EAN8	EAN8	7 digits	Numeric	118
EAN13	EAN13	12 digits	Numeric	123
FIM	FIM	n/a	A, B, C or D	129
German I-2/5	I25GERMAN	11 or 13 digits	Numeric	135
Interleaved 2/5	I-2/5	Variable	Numeric	135
ITF-14	ITF14	13 digits	Numeric	135
Matrix	MATRIX	Variable	Numeric	141
MSI	MSI	13 or 14 digits	Numeric	147
PDF417	PDF417	Variable	Alphanumeric and Control Codes	153
PostBar	POSTBAR	Variable	Numeric	163
POSTNET	POSTNET	5, 9, or 11 digits	Numeric	158
Royal Mail	ROYALBAR	Variable	Alphanumeric	163
Telepen	TELEPEN	Variable	Alphanumeric	167
UCC/EAN-128	UCC-128	Variable	Alphanumeric	173
UPC-A	UPC-A	11	Numeric	185
UPC-E and UPC-E0	UPC-E	11 or 6	Numeric	191
UPCSHIP	UPCSHIP	13 digits	Numeric	198
UPS11	UPS11	10 digits	Alphanumeric	203

User-Defined Variable Bar Code Ratios

The user-defined variable ratio for bar codes is an optional parameter. The default ratios shown in Table 8 are overridden by the variable ratio feature. Four- and eight-digit ratios can be used, depending upon the bar code selected. Ratio data must be decimal values greater than 0. Enter **R**, followed by the actual bar code ratio. A colon must separate each element of the ratio.

Like standard bar code ratios, user-defined ratios are also interpreted from left to right, measuring the size of each bar or space, in dot width, in the following pattern: *narrow bar* : *narrow space* : *wide bar* : *wide space*. Enter either four or eight values depending upon the bar code type. See Table 8 for the number of values needed.

If the **D** parameter is specified, the ratios are represented in printer dots instead of IGP dots (60 x 72 dpi).

Note



The IGP does not verify that ratio data creates acceptable wide/narrow element relationships for bar code readability. When designing unique ratio data, carefully plot wide and narrow ratios to conform to readable bar codes.

Variable Ratio Sample

```

~CREATE;TEST
SCALE;CHAR
ALPHA
2;5;1;1;*Std. Ratio*
STOP
BARCODE
C3/9;X1;H7;D;3;5
ACODE39A
PDF;B;N
STOP
/
/
ALPHA
2;30;1;1;*VAR. Ratio*
STOP
BARCODE
C3/9;XR2:2:5:5;H7;D;3;30
ACODE39A
PDF;B;N
STOP
END
~EXECUTE;TEST;1

~NORMAL

```

Std. Ratio



CODE39

VAR. Ratio



CODE39

PDF Character Sizes [PDF [:LOC] [:FONT]]

UPC and EAN

For UPC and EAN bar codes, a smaller Letter Gothic font will be substituted for OCR-A or OCR-B when the bar code symbol is not large enough to accommodate a 10 CPI font.

Other Bar Codes

For all other bar codes, OCR-A and OCR-B will print at 10 CPI. If necessary, when using the Normal font, the PDF will be automatically sized to fit the length of the bar code symbol.

Table 8. IGP/PGL Bar Code Specification Summary

Description	Magnification Parameter	Average Narrow Element Width (mils)	Character Density (cpi)	Ratio
Codabar	X1	16.7	5.4	4:3:2:1
Code 39	X1	16.7	3.75	3:1
Telepen	X1A	16.7	4.6	2:1
	X1B	16.7	4.2	2.5:1
	X2	37.5	1.9	2.3:1
	X3	54.2	1.3	2.5:1
	X4	70.8	1.1	2.4:1
Code 128A	X1	16.7	5.4	4:3:2:1
Code 128B	X1.5	25.0	4.1	4:3:2:1
Code 93	X2	33.0	2.7	4:3:2:1
UPS 11	X3	50.0	1.8	4:3:2:1
	X4	66.7	1.4	4:3:2:1
Code 128C	X1	16.7	10.9	4:3:2:1
UCC/EAN-128	X1.5	25.0	8.2	4:3:2:1
	X2	33.0	5.4	4:3:2:1
	X3	50.0	3.6	4:3:2:1
	X4	66.7	2.7	4:3:2:1
EAN 8 and 13	default	16.7	1.28 MAG	4:3:2:1
Interleaved 2/5	X1	16.7	6.7	3:1
German I-2/5	X1A	20.8	5.7	2.6:1
ITF-14	X1B	16.7	8.5	2:1
Matrix	X2	37.5	3.5	2.3:1
UPCSHIP	X2A	33.2	4.3	2:1
	X3	54.2	2.3	2.5:1
	X4	70.8	1.8	2.4:1
MSI-A	X1	16.7	6.1	3:1
MSI-B	X2	25.1	4.1	2.5:1
MSI-C	X3	33.4	3.0	2.3:1
MSI-D	X4	41.7	2.4	2.3:1
UPC-A and E	default	16.7	1.28 MAG	4:3:2:1
PostBar and Royal Mail	X1	n/a	n/a	n/a
	X1A	n/a	n/a	n/a
POSTNET	Per U.S. Postal Service <i>Publication 25: A Guide to Business Mail Preparation</i> (USPS Certified)			

Bar Codes

The rest of this chapter describes each of the bar codes available with the IGP/PGL emulation.

Codabar

The Codabar structure is shown in Figure 7 and described on the following pages.

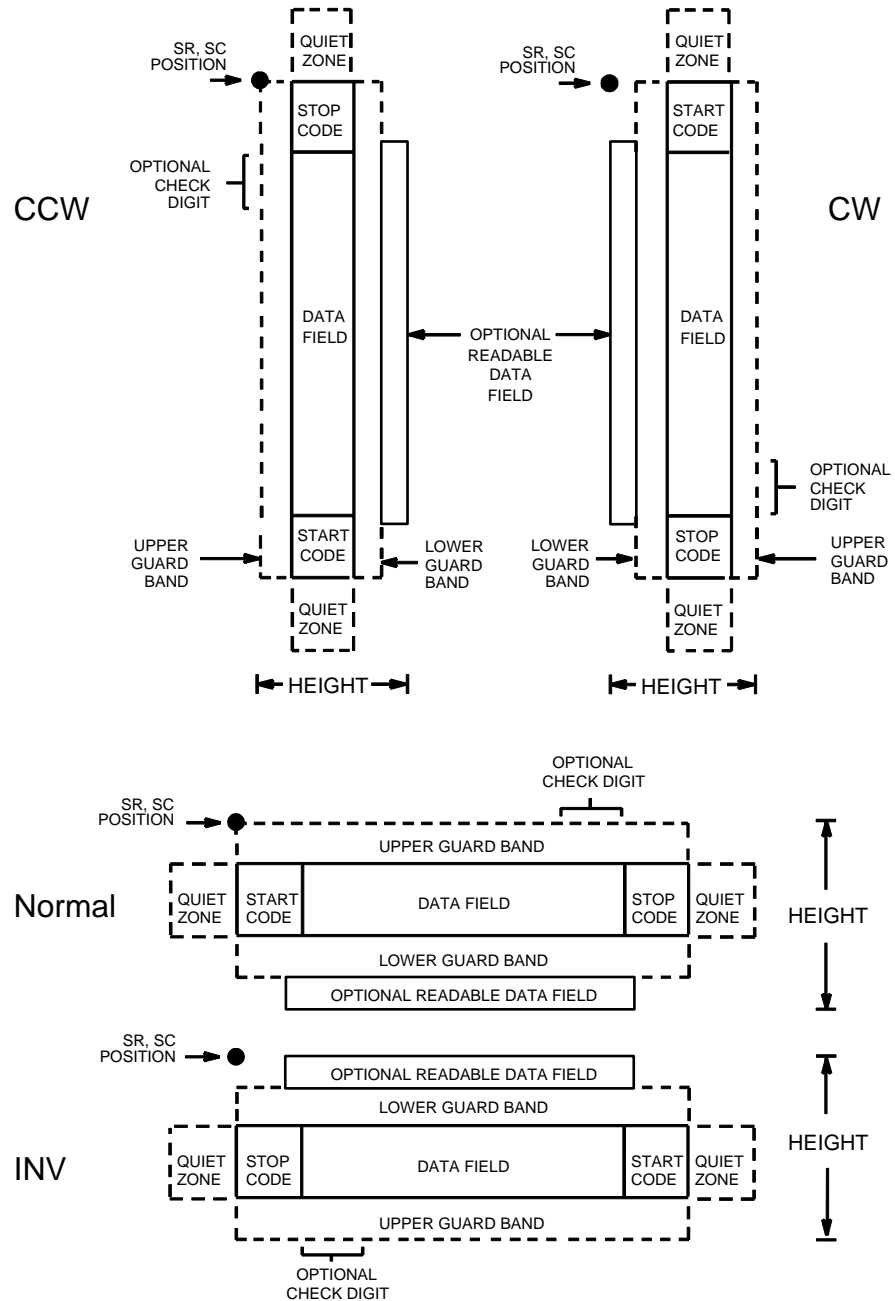

Figure 7. Codabar Structure

Quiet Zone

Both ends of the bar code structure require blank quiet zones. The quiet zones must be at least 0.25 inches wide and completely blank to ensure accurate reading of the start/stop codes and to prevent adjacent bar codes from overlapping. Be sure to provide sufficient space on the form for the quiet zones.

Start/Stop Codes

The start/stop code is a unique character identifying the leading and trailing end of the bar code. The start/stop code is automatically produced with each bar code. The start/stop code structure permits bidirectional bar code scanning.

Data Field

The bar code symbol uses a series of wide and narrow bars and spaces to represent standard alphanumeric characters. Each wide or narrow bar or space is one element; each character in the data field has nine elements. The structure is three wide elements (bars or spaces) out of the nine total elements which compose one character.

Readable Data

The optional readable data field provides a readable interpretation of the bar code data. It can be printed above or below the bar code symbol.

Check Digit

The optional modulo-43 check digit can be inserted into the bar code to verify accurate scanning.

Codabar Command Format

```

BARCODE
CODABAR [CD];[DIR;] [MAG;] [Hn[.m];] [BFn;L;] [DARK;] SR; SC
[(D)data field(D)]
[PDF [;LOC] [;FONT]]
STOP

```

BARCODE The Bar Code command; enter **BARCODE**.

CODABAR CD

Designates bar code type Codabar; enter **CODABAR**. To calculate and plot the optional modulo-43 check digit with the bar code symbol automatically, enter **CD**.

DIR

Optional parameter that allows for rotating a barcode. Enter **CW** for clockwise rotation. Enter **CCW** or **VSCAN** for counter-clockwise rotation. Enter **INV** for inverted rotation. If *DIR* is not entered, the barcode is horizontally oriented.

<i>MAG</i>	Optional parameter to magnify (horizontally expand) the bar code symbol. The magnification default value is X1 . As required for scanning, enter a magnification value from Table 8 to increase the magnification. Increasing the magnification adjusts printed character density. You can also use XR or XRD, defined on page 89.
<i>Hn[.m]</i>	Optional parameter to adjust the overall height (vertical expansion) of the bar code symbol (including the upper and lower 0.1-inch guard bands and any human readable data). Height adjustments are made in 0.1-inch increments; enter H and a value from 3 through 99 to select height adjustments from 0.3 through 9.9 inches. The default value is 0.9 inch. [.m] is an additional number of dots for the bar code height. (Dots are in the current dot scale.)



Note If 0.3 inches is the selected height, the PDF cannot be included.

<i>BFn;L</i>	Optional parameters for assigning a dynamic bar code data field location on a form and for designating the length of the data field. With these parameters, the actual data for the bar code data field is dynamically provided during the Execute Form Mode; the data is not specified during the Create Form Mode. To use this field, perform the following steps: <ol style="list-style-type: none"> Enter BF. Replace <i>n</i> with a number ranging from 1 through 512 to identify the bar code field. The <i>SR</i> and <i>SC</i> parameters specify the exact location of the bar code field identified by <i>n</i>. Replace <i>L</i> with a number equaling the total number of characters in the field. (The actual data provided dynamically during the Execute Form Mode can be less than <i>L</i>.) The information for the data field is entered dynamically during the Execute Form Mode. (Refer to “Execute Form: Dynamic Bar Code Data” on page 63.) Do not use the <i>data field</i> parameter to enter data when the <i>BFn;L</i> parameters are used. However, refer to the <i>data field</i> description for available characters.
DARK	Optional parameter to produce darker looking bar codes. Enter DARK . Refer to “Dark Printing” on page 28 for more information.

<i>SR</i>	Defines the starting row for the bar code. Enter a value ranging from row 1 to one less than the length of the form. Character row or dot row is specified based on the Scale command (page 83), or use the CP.DP format (page 26).
<i>SC</i>	Defines the starting column of the bar code. Enter a value ranging from column 1 to one less than the width of the form. Character column or dot column is specified based on the Scale command (page 83), or use the CP.DP format (page 26).
<i>(D)</i>	The printable character (delimiter) identifying the start and finish of the data field. Enter any printable character other than a slash (/), the SFCC, or a character used within the data. The same character must be used at both ends of the data field, but it is not printed with the data.
<i>data field</i>	Contains the bar code characters. A null data field (no characters) is permitted. The data field can contain any of the characters listed in Table 9 except the SFCC. The length of the data field is variable; however, the maximum length is usually limited to 32 characters to minimize potential reading errors.
<i>PDF</i>	Optional parameter to enable printing of the human readable data field. Enter PDF to print the data field. If the parameter is not used, the human readable data will not print. This parameter is not allowed if a null data field is specified.
<i>LOC</i>	Optional parameter to identify the location of the printable data field. The default value is B , locating the human readable data below the bar code. A locates the printable data field above bar code. To compensate for printing the 0.1-inch high data, the height of the bar code body is reduced 0.1 inch.
<i>FONT</i>	Optional parameter to select the font for the human readable data field. Enter O to select OCR-A font; enter X to select OCR-B font; enter N to select 10 cpi; enter P to select 12 cpi; enter Q to select 13 cpi; enter R to select 15 cpi; enter T to select 17 cpi; enter V to select 20 cpi.
<i>STOP</i>	Ends the Bar Code command while the IGP/PGL continues in the Create Form Mode. Enter STOP . If STOP is not entered, an error message results.

Table 9. Codabar Character Set

Character	Hex	Character	Hex
0	30	-	2D
1	31	\$	24
2	32	:	3A
3	33	/	2F
4	34	.	2E
5	35	+	2B
6	36	A	41
7	37	B	42
8	38	C	43
9	39	D	44

Codabar Example

```

~CREATE;TEST;288          (Enter Create Form mode)
SCALE;CHAR
BARCODE                   (Bar code command)
CODABAR;VSCAN;X1;H7;5;20
*A2345B*
PDF;B;N                   (Printable data field)
STOP                      (Ends bar code command)
END                       (Terminates Create Form mode)
~EXECUTE;TEST
~NORMAL

```

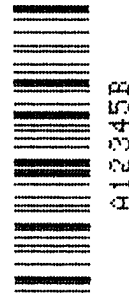

Code 39

The Code 39 structure is shown in Figure 8 and described on the following pages.

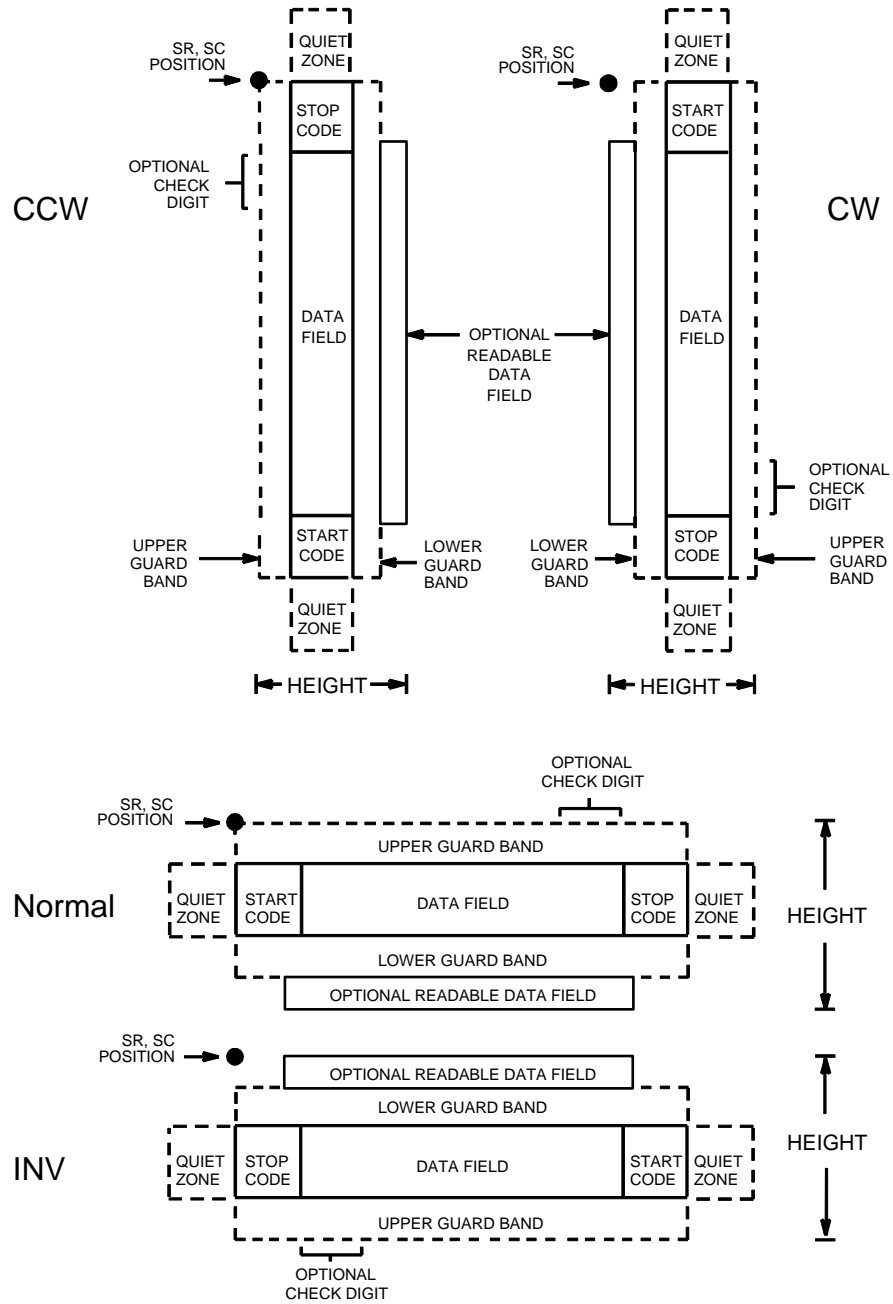

Figure 8. Code 39 Structure

Quiet Zone

Both ends of the bar code structure require blank quiet zones. The quiet zones must be at least 0.25 inches wide and completely blank to ensure accurate reading of the start/stop codes and to prevent adjacent bar codes from overlapping. Be sure to provide sufficient space on the form for the quiet zones.

Start/Stop Codes

The start/stop code is a unique character identifying the leading and trailing end of the bar code. The start/stop code is automatically produced with each bar code. The start/stop code structure permits bidirectional bar code scanning.

Data Field

The bar code symbol uses a series of wide and narrow bars and spaces to represent standard alphanumeric characters. Each wide or narrow bar or space is one element; each character in the data field has nine elements. The structure is three wide elements (bars or spaces) out of the nine total elements which compose one character.

Readable Data

The optional readable data field provides a readable interpretation of the bar code data. It can be printed above or below the bar code symbol.

Check Digit

The optional modulo-43 check digit can be inserted into the bar code to verify accurate scanning.

Code 39 Command Format

Although commonly referred to as Code “39,” you must enter the command as “C3/9” (including the slash) during IGP input.

```

BARCODE
C3/9 [CD]; [DIR;] [MAG;] [Hn[.m];] [BFn;L;] [DARK;] SR; SC
[(D)data field(D)]
[PDF [;LOC] [;FONT]]
STOP

```

BARCODE	The Bar Code command; enter BARCODE .
C3/9 CD	Designates bar code type C39; enter C3/9 . To calculate and plot the optional mod-43 check digit with the bar code symbol automatically, enter CD .
DIR	Optional parameter that allows for rotating a barcode. Enter CW for clockwise rotation. Enter CCW or VSCAN for counter-clockwise rotation. Enter INV for inverted rotation. If <i>DIR</i> is not entered, the barcode is horizontally oriented.
MAG	Optional parameter to magnify (horizontally expand) the bar code symbol. The magnification default value is X1 . As required for scanning, enter a magnification value from Table 8 to increase the magnification. Increasing the magnification adjusts printed character density. You can also use XR or XRD, defined on page 89.
Hn[.m]	Optional parameter to adjust the overall height (vertical expansion) of the bar code symbol (including the upper and lower 0.1- inch guard bands and any human readable data). Height adjustments are made in 0.1-inch increments plus dots; enter H and a value from 3 through 99 to select height adjustments from 0.3 to 9.9 inches. The default value is 0.9 inch. The [.m] provides an additional number of dots for the bar code height. (Dots are in the current dot scale.)

Note



If 0.3 inches is the selected height, the PDF cannot be included.

BFn;L	Optional parameters for assigning a dynamic bar code data field location on a form and for designating the length of the data field. With these parameters, the actual data for the bar code data field is dynamically provided during the Execute Form mode; the data is not specified during the Create Form mode. To use this field, perform the following steps: <ol style="list-style-type: none"> Enter BF.
-------	---

- b. Replace ***n*** with a number ranging from 1 through 512 to identify the bar code field. The ***SR*** and ***SC*** parameters specify the exact location of the bar code field identified by ***n***.
 - c. Replace ***L*** with a number equaling the total number of characters in the field. (The actual data provided dynamically during the Execute Form mode can be less than ***L***.)
 - d. The information for the data field is entered dynamically during the Execute Form mode. (Refer to “Execute Form: Dynamic Bar Code Data” on page 63.) Do not use the *data field* parameter to enter data when the ***BF*n*;L*** parameters are used. However, refer to the *data field* description for available characters.
- DARK** Optional parameter to produce darker bar codes. Enter **DARK**. Refer to “Dark Printing” on page 28 for more information.
- SR*** Defines the starting row for the bar code. Enter a value ranging from row 1 to one less than the length of the form. Character row or dot row is specified based on the Scale command (page 83), or use the CP.DP format (page 26).
- SC*** Defines the starting column of the bar code. Enter a value ranging from column 1 to one less than the width of the form. Character column or dot column is specified based on the Scale command (page 83), or use the CP.DP format (page 26).
- (D)*** The printable character (delimiter) identifying the start and finish of the data field. Enter any printable character other than a slash (/), the SFCC, or a character used within the data. The same character must be used at both ends of the data field, but it is not printed with the data.
- data field*** Contains the bar code characters. A null data field (no characters) is permitted. The data field can contain any of the characters listed in Table 10. The length of the data field is variable; however, the maximum length is usually limited to 32 characters to minimize potential reading errors.
- PDF** Optional parameter to enable printing of the human readable data field. Enter **PDF** to print the data field. If the parameter is not used, the human readable data will not print. This parameter is not allowed if a null data field is specified.
- LOC*** Optional parameter to identify the location of the printable data field. The default value is **B**, locating the human readable data below the bar code. **A** locates the printable data field above the bar code.

To compensate for printing the 0.1-inch high data, the height of the bar code body is reduced 0.1 inch.

FONT Optional parameter to select the font for the human readable data field. Enter **O** to select OCR-A font; enter **X** for OCR-B font; enter **N** for 10 cpi; enter **P** for 12 cpi; enter **Q** for 13 cpi; enter **R** for 15 cpi; enter **T** for 17 cpi; enter **V** for 20 cpi.

STOP Ends the Bar Code command while the IGP continues in the Create Form mode. Enter **STOP**. If **STOP** is not entered, an error message results.

Table 10. Code 39 Character Set

ASCII	CODE 39	ASCII	CODE 39	ASCII	CODE 39	ASCII	CODE 39
NUL	%U	SP	Space	@	%V	`	%W
SOH	\$A	!	/A	A	A	a	+A
STX	\$B	"	/B	B	B	b	+B
ETX	\$C	#	/C	C	C	c	+C
EOT	\$D	\$	/D	D	D	d	+D
ENQ	\$E	%	/E	E	E	e	+E
ACK	\$F	&	/F	F	F	f	+F
BEL	\$G	'	/G	G	G	g	+G
BS	\$H	(/H	H	H	h	+H
HT	\$I)	/I	I	I	i	+I
LF	\$J	*	/J	J	J	j	+J
VT	\$K	+	/K	K	K	k	+K
FF	\$L	,	/L	L	L	l	+L
CR	\$M	—	—	M	M	m	+M
SO	\$N	.	/N	N	N	n	+N
SI	\$O	/	/O	O	O	o	+O
DLE	\$P	0	0	P	P	p	+P
DC1	\$Q	1	1	Q	Q	q	+Q
DC2	\$R	2	2	R	R	r	+R
DC3	\$S	3	3	S	S	s	+S
DC4	\$T	4	4	T	T	t	+T
NAK	\$U	5	5	U	U	u	+U
SYN	\$V	6	6	V	V	v	+V
ETB	\$W	7	7	W	W	w	+W
CAN	\$X	8	8	X	X	x	+X
EM	\$Y	9	9	Y	Y	y	+Y
SUB	\$Z	:	/Z	Z	Z	z	+Z
ESC	%A	;	%F	[%K	{	%P
FS	%B	<	%G	\	%L		%Q
GS	%C	=	%H]	%M	}	%R
RS	%D	>	%I	^	%N	~	%S
US	%E	?	%J	—	%O	DEL	%T %X %Y %Z

Note



Character pairs /M, /N, and /P through /Y are reserved for future control character pairs.

Code 39 Example

Figure 9 illustrates a horizontal and vertical Code 39 bar code generated by the following program:

```

~CREATE;C39           (Enter Create Form mode)
BARCODE              (Bar Code Command)
C3/9;DARK;40;15      (Dark Code 39 at SR 40, SC 15)
*SAMPLE C3/9*        (Data Field)
PDF                  (Printable Data Field)
STOP                 (Ends Bar Code Command)
BARCODE              (New Bar Code Command)
C3/9;VSCAN;H14;DARK;27;58
                    (Vert Dark Code 39, H 1.4, at SR 27, SC 58)
*SAMPLE C3/9*        (Data Field)
PDF                  (Printable Data Field)
STOP                 (Ends Bar Code Command)
END                  (Terminates Create Form mode)
~EXECUTE;C39;1       (Execute the form, form count of 1)

```



Figure 9. Sample Code 39 Bar Codes

Code 93

The Code 93 structure is shown in Figure 10 and described on the following pages.

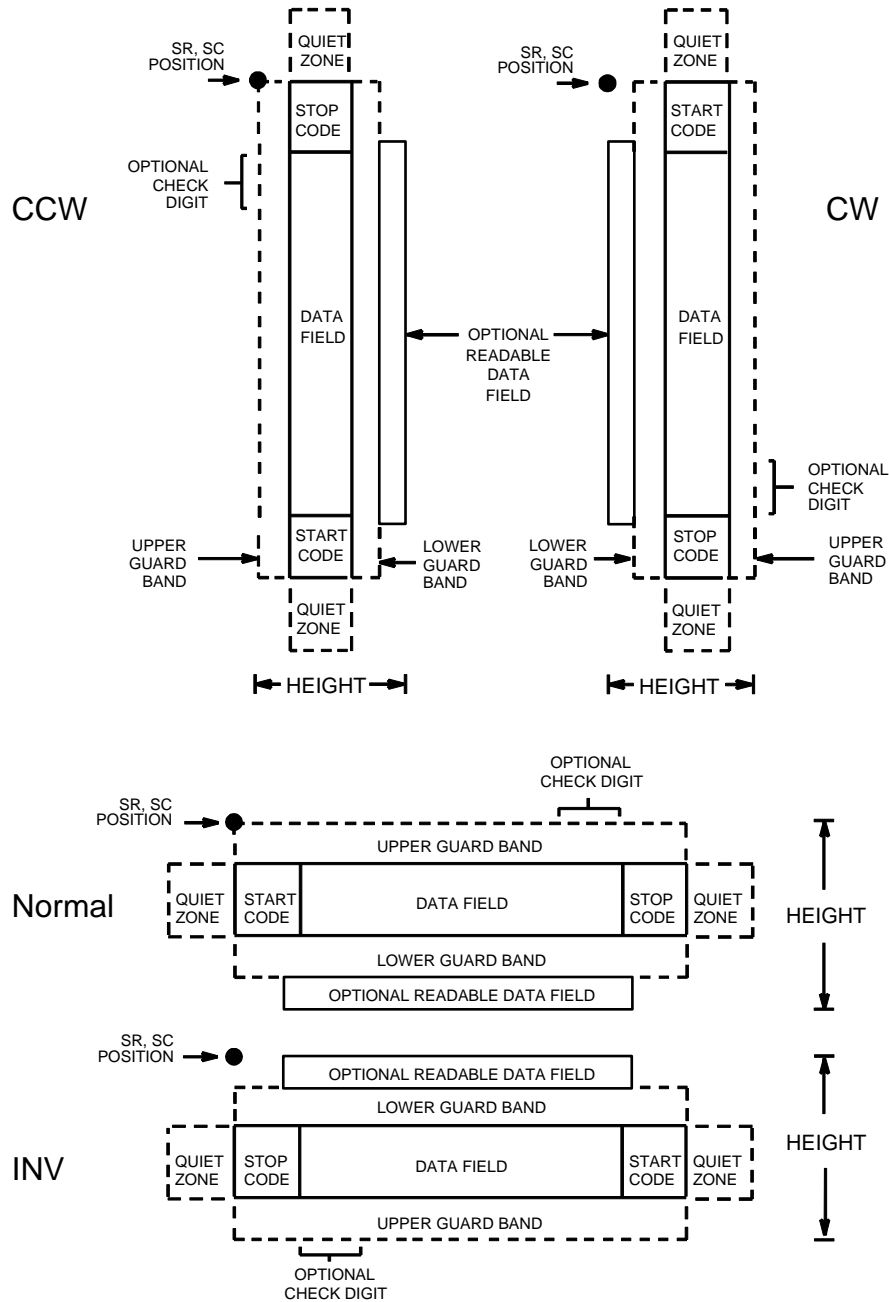

Figure 10. Code 93 Structure

Quiet Zone

Both ends of the bar code structure require blank quiet zones. The quiet zones must be at least 0.25 inches wide and completely blank to ensure accurate reading of the start/stop codes and to prevent adjacent bar codes from overlapping. Be sure to provide sufficient space on the form for the quiet zones.

Start/Stop Codes

The start/stop codes identify the leading and trailing end of the bar code.

Data Field

The bar code symbol uses a series of varying width bars and spaces to represent an extensive character set. The bars and spaces vary in width from one to four modules. Each character consists of three bars and three spaces that total 11 modules.

Readable Data

The optional readable data field provides a readable interpretation of the bar code data. It can be printed above or below the bar code symbol.

Check Digit

The modulo-103 check digit is automatically calculated and inserted in the bar code symbol. The check digit verifies accurate scanning. The start code is included in the check digit algorithm.

Code 93 Command Format

BARCODE	
CODE93;	[<i>DIR</i> ;] [<i>MAG</i> ;] [<i>Hn</i>]. <i>m</i> ;] [<i>BFn</i> ;L;][<i>DARK</i> ;] <i>SR</i> ; <i>SC</i>
	[(<i>D</i>) <i>data field</i> (<i>D</i>)
	[<i>PDF</i> [; <i>LOC</i>] [; <i>FONT</i>]]
STOP	
BARCODE	The Bar Code command; enter BARCODE .
CODE93	Designates bar code type Code 93; enter CODE93 .
<i>DIR</i>	Optional parameter that allows for rotating a barcode. Enter CW for clockwise rotation. Enter CCW or VSCAN for counter-clockwise rotation. Enter INV for inverted rotation. If <i>DIR</i> is not entered, the barcode is horizontally oriented.
<i>MAG</i>	Optional parameter to magnify (horizontally expand) the bar code symbol. The magnification default value is X1 . Increasing the magnification adjusts printed character density as shown in Table 8. You can also use <i>XR</i> or <i>XRD</i> as defined on page 89. (You must specify 8 digits for <i>MAG</i> for variable ratio.)
<i>Hn</i>]. <i>m</i>	Optional parameter to adjust the overall height (vertical expansion) of the bar code symbol (including the upper and lower 0.1-inch guard bands and any human readable data). Height adjustments are made in 0.1-inch increments; enter H and a value from 3 through 99 to select height adjustments from 0.3 through 9.9 inches. The default value is 0.9 inch. [<i>m</i>] is an additional number of dots for the bar code height. (Dots are in the current dot scale.)

Note



If 0.3 inches is the selected height, the PDF cannot be included.

<i>BFn</i> ;L	Optional parameters for assigning a dynamic bar code data field location on a form and for designating the length of the data field. With these parameters, the actual data for the bar code data field is dynamically provided during the Execute Form Mode; the data is not specified during the Create Form Mode. To use this field, perform the following steps: <ol style="list-style-type: none"> Enter BF. Replace <i>n</i> with a number ranging from 1 through 512 to identify the bar code field. The <i>SR</i> and <i>SC</i> parameters specify the exact location of the bar code field identified by <i>n</i>.
---------------	--

- c. Replace *L* with a number equaling the total number of characters in the field. (The actual data provided dynamically during the Execute Form Mode can be less than *L*.)
 - d. The information for the data field is entered dynamically during the Execute Form Mode. (Refer to “Execute Form: Dynamic Bar Code Data” on page 63.) Do not use the *data field* parameter to enter data when the *BFn;L* parameters are used. However, refer to the *data field* description for available characters.
- DARK** Optional parameter to produce darker looking bar codes. Enter **DARK**. Refer to “Dark Printing” on page 28 for more information.
- SR** Defines the starting row for the bar code. Enter a value ranging from row 1 to one less than the length of the form. Character row or dot row is specified based on the Scale command (page 83), or use the CP.DP format (page 26).
- SC** Defines the starting column of the bar code. Enter a value ranging from column 1 to one less than the width of the form. Character column or dot column is specified based on the Scale command (page 83), or use the CP.DP format (page 26).
- (D)** The printable character (delimiter) identifying the start and finish of the data field. Enter any printable character other than a slash (/), the SFCC, or a character used within the data. The same character must be used at both ends of the data field, but it will not print with the data.
- data field* Enter the data for the bar code. A null data field (no characters) is permitted. The length of the data field is variable; however, the maximum length is usually limited to 32 characters to minimize potential reading errors. The data field can contain any of the characters listed in Table 11, except the system SFCC.
- PDF** Optional parameter to enable printing of the human readable data field. Enter **PDF** to print the data field. If the parameter is not used, the human readable data will not print. This parameter is not allowed if a null data field was specified.
- LOC** Optional parameter to identify the location of the printable data field. The default value is **B**, locating the human readable data below the bar code. **A** locates the printable data field above bar code. To compensate for printing the 0.1-inch high data, the height of the bar code body is reduced 0.1 inch.

- FONT** Optional parameter to select the font for the human readable data field. Enter **O** to select OCR-A font; enter **X** to select OCR-B font; enter **N** to select 10 cpi; enter **P** to select 12 cpi; enter **Q** to select 13 cpi; enter **R** to select 15 cpi; enter **T** to select 17 cpi; enter **V** to select 20 cpi.
- STOP** Ends the Bar Code command while the IGP/PGL continues in the Create Form Mode. Enter **STOP**. If STOP is not entered, an error message results.

Table 11. Code 93 Character Set

Character	Hex	Character	Hex
0	30	P	50
1	31	Q	51
2	32	R	52
3	33	S	53
4	34	T	54
5	35	U	55
6	36	V	56
7	37	W	57
8	38	X	58
9	39	Y	59
A	41	Z	5A
B	42	—	2D
C	43	.	2E
D	44	SPACE	20
E	45	\$	3F
F	46	/	2F
G	47	+	2B
H	48	%	25
I	49	S1	N/A
J	4A	S2	N/A
K	4B	S3	N/A
L	4C	S4	NA
M	4D	Start	N/A
N	4E	Stop	N/A
O	4F		

Code 93 Example

The illustration below shows a horizontal Code 93 bar code generated by the following program:

```
~CREATE;TEST;288           (Enters Create Form mode)
SCALE;CHAR                 (Bar code command)
BARCODE
CODE93;X1;H7;10;20
*ABCD5678*                 (Printable data field)
PDF;B;N                    (Ends bar code command)
STOP                       (Terminates Create Form mode)
END                         (Prints form)
~EXECUTE;TEST
~NORMAL
```

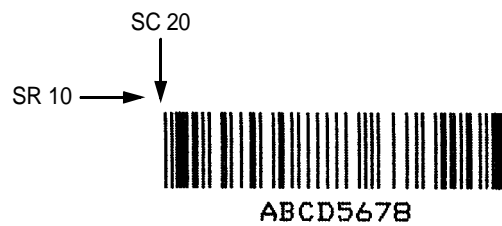

Code 128A, 128B and 128C

The Code 128 structure is shown in Figure 11 and described on the following pages.

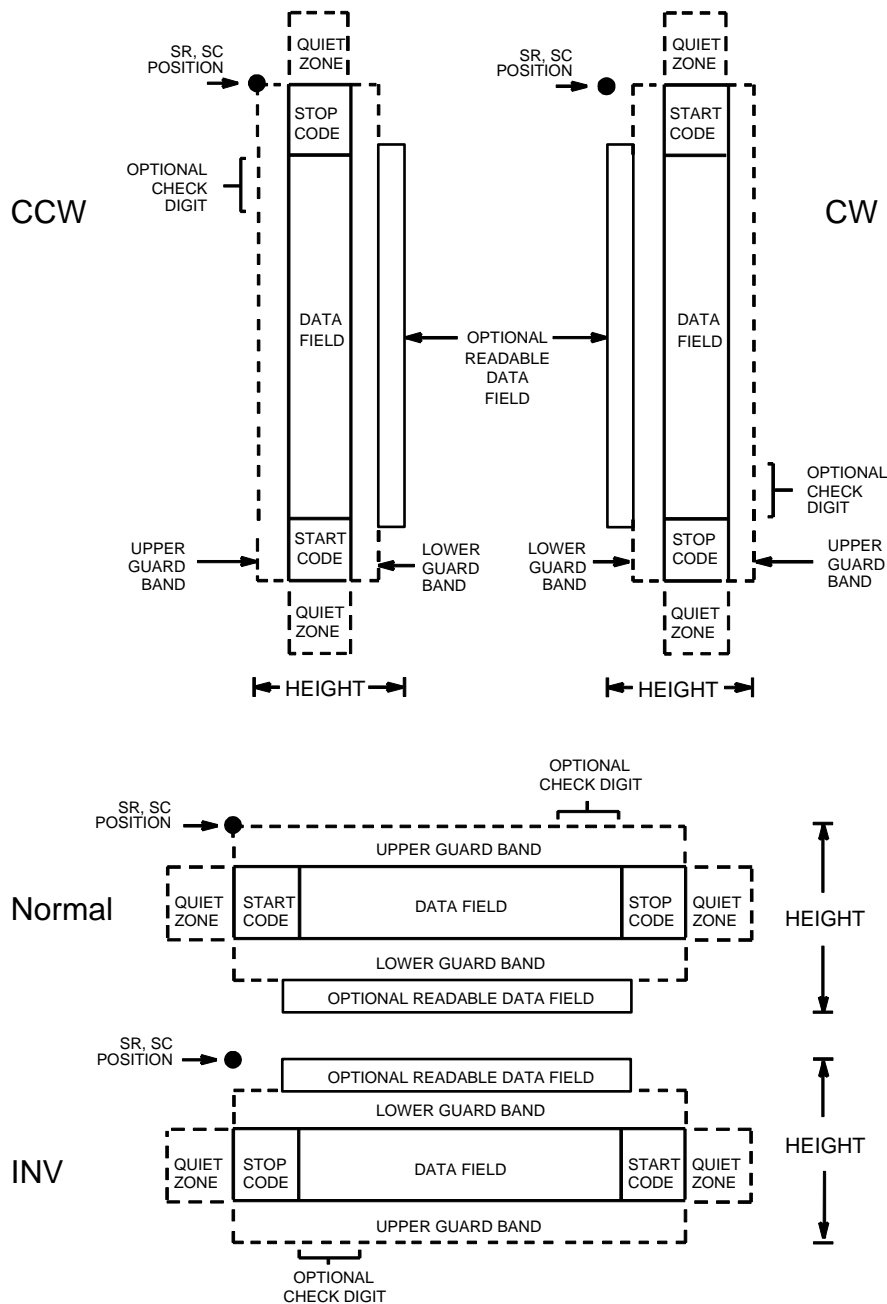

Figure 11. Code 128 Structure

Quiet Zone

Both ends of the bar code structure require blank quiet zones. The quiet zones must be at least 0.25 inches wide and completely blank to ensure accurate reading of the start/stop codes and to prevent adjacent bar codes from overlapping. Be sure to provide sufficient space on the form for the quiet zones.

Start/Stop Codes

The start/stop codes identify the leading and trailing end of the bar code. Each of the Code 128 subsets uses a unique start code and a common stop code, both automatically provided by the IGP.

Code 128A Data Field

Although the command field does not allow the selection of Code A, the IGP does encode these characters if found in the data.

Code 128B Data Field

The bar code symbol uses a series of varying width bars and spaces to represent an extensive character set (96 ASCII characters and seven control characters). The bars and spaces vary in width from one to four modules. Each character consists of three bars and three spaces that total 11 modules.

Code 128C Data Field

The bar code symbol uses a series of varying width bars and spaces to represent 100 pairs of numeric digits (00 through 99) and 3 control characters. The bars and spaces vary in width from 1 to 4 modules. Each character consists of three bars and three spaces that total 11 modules.

Readable Data

The optional readable data field provides a readable interpretation of the bar code data. It can be printed above or below the bar code symbol.

Check Digit

The modulo-103 check digit is automatically calculated and inserted in the bar code symbol. The check digit verifies accurate scanning. The start code is included in the check digit algorithm.

Code 128 Command Format

BARCODE

C128A or C128B or C128C;[DIR;] [MAG;] [Hn[.m];] [BFn;L;]

[DARK;]SR;SC

[(D)data field(D)]

[PDF [;LOC] [;FONT]]

STOP

BARCODE The Bar Code command; enter **BARCODE**.

C128A, C128B or C128C)

Designates bar code type; enter **C128A**, **C128B** or **C128C**.

DIR Optional parameter that allows for rotating a barcode. Enter **CW** for clockwise rotation. Enter **CCW** or **VSCAN** for counter-clockwise rotation. Enter **INV** for inverted rotation. If *DIR* is not entered, the barcode is horizontally oriented.

MAG Optional parameter to magnify (horizontally expand) the bar code symbol. The magnification default value is **X1**. Increasing the magnification adjusts printed character density as shown in Table 8. You can also use **XR** or **XRD** as defined on page 89. (You must specify 8 digits for *MAG* for variable ratio.)

Hn[.m] Optional parameter to adjust the overall height (vertical expansion) of the bar code symbol (including the upper and lower 0.1-inch guard bands and any human readable data). Height adjustments are made in 0.1-inch increments; enter **H** and a value from **3** through **99** to select height adjustments from 0.3 to 9.9 inches. The default value is 0.9 inch. The *[.m]* provides an additional number of dots for the bar code height. (Dots are in the current dot scale.)

Note



If 0.3 inches is the selected height, the PDF cannot be included.

BFn;L Optional parameters for assigning a dynamic bar code data field location on a form and for designating the length of the data field. With these parameters, the actual data for the bar code data field is dynamically provided during the Execute Form mode; the data is not specified during the Create Form mode. To use this field, perform the following steps:

- a. Enter **BF**.

- b. Replace n with a number ranging from 1 to 512 to identify the bar code field. The SR and SC parameters specify the exact location of the bar code field identified by n .
 - c. Replace L with a number equaling the total number of characters in the field. (The actual data provided dynamically during the Execute Form mode can be less than L .)
 - d. The information for the data field is entered dynamically during the Execute Form mode. (Refer to “Execute Form: Dynamic Bar Code Data” on page 63.) Do not use the *data field* parameter to enter data when the $BFn;L$ parameters are used. Refer to the *data field* description for available characters.
- DARK** Optional parameter to produce darker bar codes. Enter **DARK**. Refer to “Dark Printing” on page 28 for more information.
- SR** Defines the starting row for the bar code. Enter a value ranging from row 1 to one less than the length of the form. Character row or dot row is specified based on the Scale command (page 83), or use the CP.DP format (page 26).
- SC** Defines the starting column of the bar code. Enter a value ranging from column 1 to one less than the width of the form. Character column or dot column is specified based on the Scale command (page 83), or use the CP.DP format (page 26).
- (D)** The printable character (delimiter) identifying the start and finish of the data field. Enter any printable character other than a slash (/), the SFCC, or a character used within the data. The same character must be used at both ends of the data field, but it will not print with the data.
- data field*** Enter the data for the bar code. A null data field (no characters) is permitted. Whenever a string of 4 or more contiguous numeric digits are detected, the IGP/PGL automatically inserts a Code C at the start of the numeric string and outputs numeric digit pairs packed into single bar code characters. When the string is broken (non-numeric data or an unpaired numeric digit occurs), the IGP/PGL automatically inserts either a Code A or Code B and returns to their respective symbols. The length of the data field is variable; however, the maximum length is usually limited to 32 characters to minimize potential reading errors. The data field can contain any of the characters listed in Table 12, Table 13 and Table 14, beginning on page 113.

PDF	Optional parameter to enable printing of the human readable data field. Enter PDF to print the data field. If the parameter is not used, the human readable data will not print. This parameter is not allowed if a null data field was specified.
LOC	Optional parameter to identify the location of the printable data field. The default value is B , locating the human readable data below the bar code. A locates the printable data field above bar code. To compensate for printing the 0.1-inch high data, the height of the bar code body is reduced 0.1 inch.
FONT	Optional parameter to select the font for the human readable data field. Enter O to select OCR-A font; enter X to select OCR-B font; enter N to select 10 cpi; enter P to select 12 cpi; enter Q to select 13 cpi; enter R to select 15 cpi; enter T to select 17 cpi; enter V to select 20 cpi.
STOP	Ends the Bar Code command while the IGP continues in the Create Form mode. Enter STOP . If STOP is not entered, an error message results.

Table 12. Code 128A Character Set

Character	Hex	Character	Hex	Character	Hex	Character	Hex
NUL	00	SUB	1A	4	34	N	4E
SOH	01	ESC	1B	5	35	O	4F
STX	02	FS	1C	6	36	P	50
ETX	03	GS	1D	7	37	Q	51
EOT	04	RS	1E	8	38	R	52
ENQ	05	US	1F	9	39	S	53
ACK	06	SP	20	:	3A	T	54
BEL	07	!	21	;	3B	U	55
BS	08	"	22	<	3C	V	56
HT	09	#	23	=	3D	W	57
LF	0A	\$	24	>	3E	X	58
VT	0B	%	25	?	3F	Y	59
FF	0C	&	26	@	40	Z	5A
CR	0D	,	27	A	41	[5B
SO	0E	(28	B	42	\	5C
SI	0F)	29	C	43]	5D
DLE	10	*	2A	D	44	^	5E
DC1	11	+	2B	E	45	^	5F
DC2	12	,	2C	F	46	FNC 3	23 See NOTE
DC3	13	-	2D	G	47	FNC 2	22 See NOTE
DC4	14	.	2E	H	48	SHIFT	28 See NOTE
NAK	15	/	2F	I	49	CODE C	27 See NOTE
SYN	16	0	30	J	4A	FUNC 4	24 See NOTE
ETB	17	1	31	K	4B	CODE B	26 See NOTE
CAN	18	2	32	L	4C	FNC 1	21 See NOTE
EM	19	3	33	M	4D	START A	(N/A)
						STOP	(N/A)

Note

Access for the alternate set of control function characters is by using SO (Shift Out, decimal 14, hex 0E). The SO control code identifies the next character as the control function character, which must be inserted before each alternate character required.

The SO control code can be changed to any decimal value from 0 through 255 using the printer's front panel. See the "Configuration Menus" chapter in your *User's Guide*.

Table 13. Code 128B Character Set

Character	Hex	Character	Hex	Character	Hex	Character	Hex
SP	20	:	3A	T	54	n	6E
!	21	;	3B	U	55	o	6F
"	22	<	3C	V	56	p	70
#	23	=	3D	W	57	q	71
\$	24	>	3E	X	58	r	72
%	25	?	3F	Y	59	s	73
&	26	@	40	Z	5A	t	74
'	27	A	41	[5B	u	75
(28	B	42	\	5C	v	76
)	29	C	43]	5D	w	77
*	2A	D	44		5E	x	78
+	2B	E	45	-	5F	y	79
,	2C	F	46	'	60	z	7A
-	2D	G	47	a	61	{	7B
.	2E	H	48	b	62		7C
/	2F	I	49	c	63	}	7D
0	30	J	4A	d	64	~	7E
1	31	K	4B	e	65	■	7F
2	32	L	4C	f	66	FNC 3	23 See NOTE
3	33	M	4D	g	67	FNC 2	22 See NOTE
4	34	N	4E	h	68	SHIFT	28 See NOTE
5	35	O	4F	i	69	CODE C	27 See NOTE
6	36	P	50	j	6A	FUNC 4	24 See NOTE
7	37	Q	51	k	6B	CODE A	25 See NOTE
8	38	R	52	l	6C	FNC 1	21 See NOTE
9	39	S	53	m	6D	START B	(N/A)
						STOP	(N/A)

Note

Access for the alternate set of control function characters is by using SO (Shift Out, decimal 14, hex 0E). The SO control code identifies the next character as the control function character, which must be inserted before each alternate character required.

The SO control code can be changed to any decimal value from 0 through 255 using the printer's front panel. See the "Configuration Menus" chapter in your *User's Guide*.

Table 14. Code 128C Character Set

Character	Hex	Character	Hex	Character	Hex	Character	Hex
00	30 30	27	32 37	54	35 34	81	38 31
01	30 31	28	32 38	55	35 35	82	38 32
02	30 32	29	32 39	56	35 36	83	38 33
03	30 33	30	33 30	57	35 37	84	38 34
04	30 34	31	33 31	58	35 38	85	38 35
05	30 35	32	33 32	59	35 39	86	38 36
06	30 36	33	33 33	60	36 30	87	38 37
07	30 37	34	33 34	61	36 31	88	38 38
08	30 38	35	33 35	62	36 32	89	38 39
09	30 39	36	33 36	63	36 33	90	39 30
10	31 30	37	33 37	64	36 34	91	39 31
11	31 31	38	33 38	65	36 35	92	39 32
12	31 32	39	33 39	66	36 36	93	39 33
13	31 33	40	34 30	67	36 37	94	39 34
14	31 34	41	34 31	68	36 38	95	39 35
15	31 35	42	34 32	69	36 39	96	39 36
16	31 36	43	34 33	70	37 30	97	39 37
17	31 37	44	34 34	71	37 31	98	39 38
18	31 38	45	34 35	72	37 32	99	39 39
19	31 39	46	34 36	73	37 33	CODE B	26 See NOTE
20	32 30	47	34 37	74	37 34	CODE A	25 See NOTE
21	32 31	48	34 38	75	37 35	FNC 1	21 See NOTE
22	32 32	49	34 39	76	37 36	START C	(N/A)
23	32 33	50	35 30	77	37 37	STOP	(N/A)
24	32 34	51	35 31	78	37 38		
25	32 35	52	35 32	79	37 39		
26	32 36	53	35 33	80	38 30		

Note

Access for the alternate set of control function characters is by using SO (Shift Out, decimal 14, hex 0E). The SO control code identifies the next character as the control function character, and must be inserted before each alternate character required.

The SO control code can be changed to any decimal value from 0 through 255 using the printer's front panel. See the "Configuration Menus" chapter in your *User's Guide*.

Code 128B Example

Figure 12 illustrates a horizontal and vertical Code 128B bar code generated by the following program:

```

~CREATE;128B          (Enter Create Form mode)
BARCODE              (Bar Code command)
C128B;DARK;40;15     (Dark Code 128B at SR 40, SC 15)
*SAMPLE CODE 128B*   (Data Field)
PDF;A                (Upper Printable Data Field)
STOP                 (Ends Bar Code command)
BARCODE              (New Bar Code command)
C128B;VSCAN;H12;DARK;31;55
                    (Vert. Dark C128B, H 1.2 at SR 31, SC 55)
*SAMPLE CODE 128B*   (Data Field)
PDF                  (Printable Data Field)
STOP                 (Ends Bar Code command)
END                  (Terminate Create Form mode)
~EXECUTE;128B;1      (Execute the form, form count of 1)

```

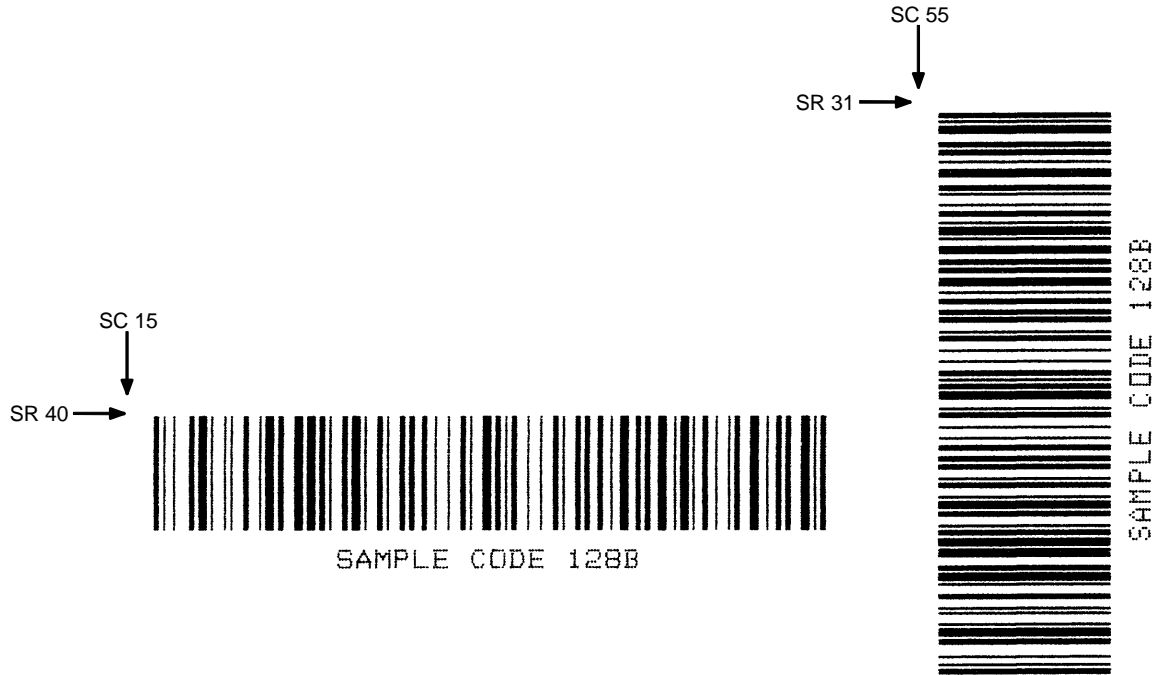

Figure 12. Sample Code 128B Bar Codes

Code 128C Example

Figure 13 illustrates a horizontal and vertical Code 128C bar code generated by the following program:

```

~CREATE;128C          (Enter Create Form mode)
BARCODE              (Bar Code command)
C128C;DARK;35;15    (Dark Code 128C at SR 35,SC 15)
*1234567890*        (Data Field)
PDF                  (Printable Data Field)
STOP                 (Ends Bar Code command)
BARCODE              (New Bar Code command)
C128C;VSCAN;H12;DARK;27;50
                    (Vert. Dark C128C, H 1.2 at SR 27, SC 50)
*1234567890*        (Data Field)
PDF                  (Printable Data Field)
STOP                 (Ends Bar Code command)
END                  (Terminates Create Form mode)
~EXECUTE;128C;1     (Execute the form, form count of 1)

```



Figure 13. Sample Code 128C Bar Codes

EAN 8

The EAN 8 bar code structure is shown in Figure 14 and described on the following pages.

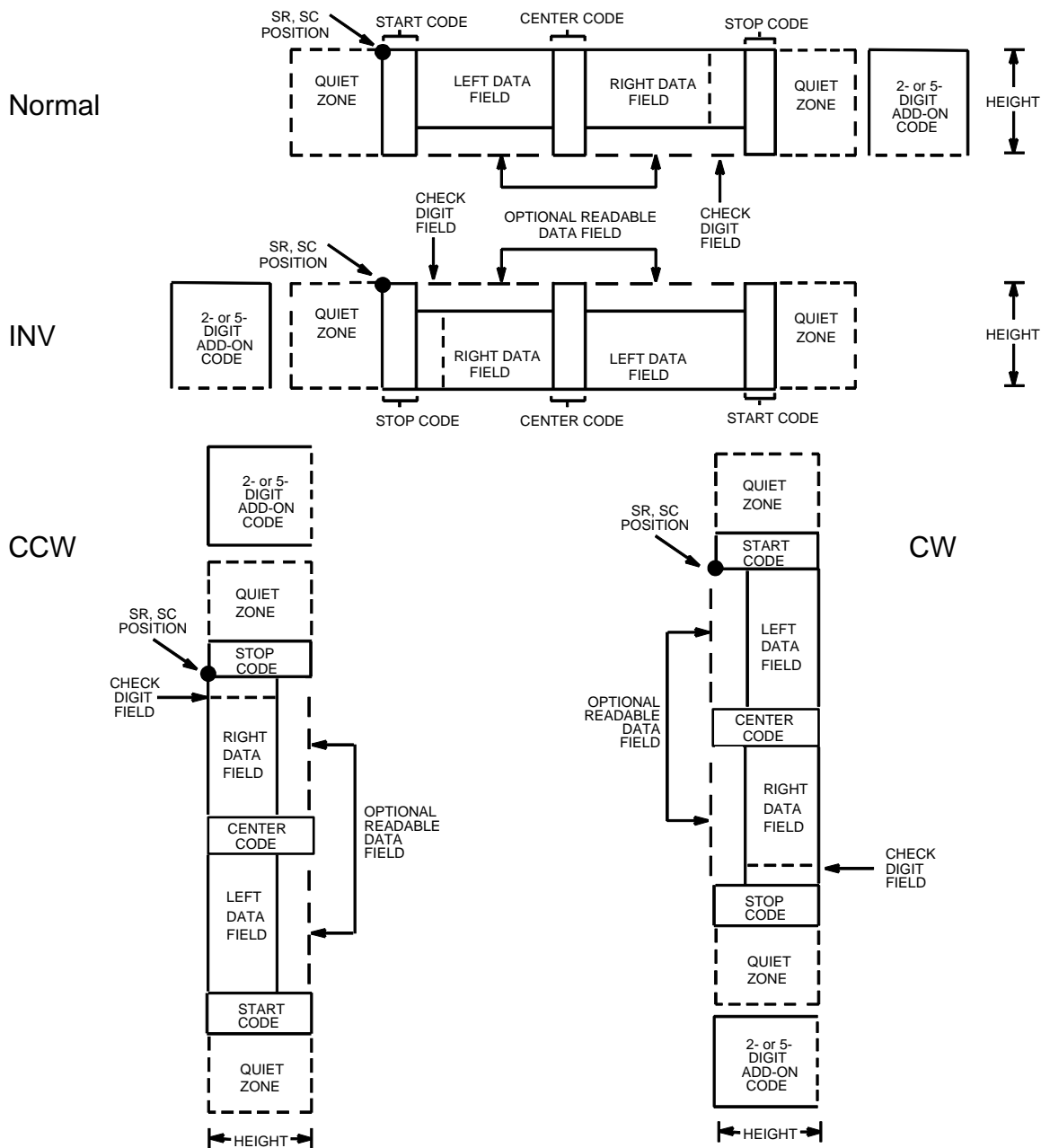

Figure 14. EAN 8 Structure

Quiet Zone

Both ends of the bar code structure have blank quiet zones. The quiet zones must be at least 0.25 inches wide and completely blank to ensure accurate reading of the start/stop codes and to prevent adjacent bar codes from overlapping. The IGP automatically produces the left quiet zone; you must provide sufficient space on the form for the right quiet zone.

Start/Center/Stop Codes

The start/center/stop codes are special character codes marking those portions of the bar code. These codes are automatically provided.

Data Field

The bar code symbol uses a series of varying width bars and spaces to represent a limited character set (numbers 0-9 and Special Characters Start, Center, and Stop). The bars and spaces vary in width from one to four modules. Each character consists of two bars and two spaces that total seven modules. The symbol coding of the left data field is different from the right data field to permit read direction sensing.

The optional 2- or 5-digit add-on data, placed at the end of the bar code, typically identifies a periodical issue number or price, respectively.

Readable Data

The human readable data field provides a readable interpretation of the bar code data. It can either be suppressed or printed above or below the bar code symbol.

Check Digit

The modulo-10 check digit is automatically calculated and inserted in the bar code symbol. The check digit verifies accurate scanning.

EAN 8 Command Format

BARCODE

EAN8 [+*n*];[*DIR*];[*SCB*];[*MAG*];[*Hn*].*m*];[*BFn*];[*DARK*]; *SR*; *SC*
[*(D)*data field(*D*)]

[*PDF* [; *LOC*] [; *FONT*]]

STOP

BARCODE The Bar Code command; enter **BARCODE**.

EAN8 Designates bar code type EAN 8; enter **EAN8**.

+*n* Optional parameter to provide a 2- or 5-digit add-on code at the end of the bar code data field. Enter a plus sign (+) and a value of **2** or **5**. The first bar of the add-on code is separated by nine modules from the last bar of the EAN symbol and a left guard pattern. No center or right guard pattern exists.

DIR Optional parameter that allows for rotating a barcode. Enter **CW** for clockwise rotation. Enter **CCW** or **VSCAN** for counter-clockwise rotation. Enter **INV** for inverted rotation. If ***DIR*** is not entered, the barcode is horizontally oriented.

SCB This option shortens the length of the center guard bars, which are normally full length.

MAG Optional parameter to magnify (horizontally expand) the bar code symbol. The magnification default value is **X1**. Increasing the magnification adjusts printed character density as shown in Table 8. You can also use **XR** or **XRD** as defined on page 89. (You must specify 8 digits for ***MAG*** for variable ratio.)

Hn*].*m Optional parameter to adjust the overall height (vertical expansion) of the bar code symbol (including the upper and lower 0.1-inch guard bands and any human readable data). Height adjustments are made in 0.1-inch increments; enter **H** and a value from 4 through 99 to select height adjustments from 0.4 through 9.9 inches. The default value is 1.3 inches. The **].*m*** provides an additional number of dots for the bar code height. (Dots are in the current dot scale.)

BFn Optional parameter for assigning a dynamic bar code data field location on a form. With this parameter, the actual data for the bar code data field is provided dynamically during the Execute Form mode; the data is not specified during the Create Form mode. To use this field:

- a. Enter **BF**.

- b. Replace *n* with a number ranging from 1 through **512** to identify the bar code field. The *SR* and *SC* parameters specify the exact location of the bar code field identified by *n*.
- c. The length of the data field need not be specified since it is fixed at seven digits, plus any add-on data.
- d. The information for the data field is entered dynamically during the Execute Form mode. (Refer to “Execute Form: Dynamic Bar Code Data” on page 63.) Do not use the *data field* parameter to enter data when the *BFn* parameters are used. However, refer to the *data field* description for available characters.

DARK	Optional parameter to produce darker looking bar codes. Enter DARK . Refer to “Dark Printing” on page 28 for more information.
<i>SR</i>	Defines the starting row for the bar code. Enter a value ranging from row 1 to one less than the length of the form. Character row or dot row is specified based on the Scale command (page 83), or use the CP.DP format (page 26).
<i>SC</i>	Defines the starting column of the bar code. Enter a value ranging from column 1 to one less than the width of the form. Character column or dot column is specified based on the Scale command (page 83), or use the CP.DP format (page 26).
(<i>D</i>)	The printable character (delimiter) identifying the start and finish of the data field. Enter any printable character other than a slash (/), the SFCC, or a character used within the data. The same character must be used at both ends of the data field, but it is not printed with the data.
<i>data field</i>	The characters of the bar code data are restricted to exactly seven digits. If the 2- or 5-digit add-on data option is used, include this data at the end of the data field. The characters available for the data field are 0 through 9 (30 through 39 hex, respectively).
PDF	Optional parameter to print the human readable data field. The data field prints automatically unless the PDF-suppress command is specified in the <i>FONT</i> parameter. The human readable data field can be printed above or below the bar code symbol. If no PDF command is entered, the data field will print automatically in the default OCR-B font.

LOC Optional parameter to identify the location of the printable data field. The default value is **B**, locating the human readable data below the bar code. **A** locates the printable data field above the bar code. To compensate for printing the 0.1-inch high data, the height of the bar code body is reduced 0.1 inch.

FONT Optional parameter to select the font for the human readable data field. Enter **O** to select OCR-A font; enter **X** to select OCR-B font; enter **N** to select 10 cpi; enter **P** to select 12 cpi; enter **Q** to select 13 cpi; enter **R** to select 15 cpi; enter **T** to select 17 cpi; enter **V** to select 20 cpi. Enter **S** to suppress printing the data field and the trailing lower portions of the EAN bar code.

STOP Ends the Bar Code command while the IGP continues in the Create Form mode. Enter **STOP**. If **STOP** is not entered, an error message results.

EAN 8 Example

Figure 15 illustrates a horizontal and vertical EAN 8 bar code generated by the following program:

```

~CREATE;EAN8          (Enter Create Form mode)
BARCODE              (Bar Code command)
EAN8+2;H9;DARK;33;15(Dark Code EAN 8, 2-digit add-on,
                    H 0.9, SR 33, SC 15)
*123456722*         (Data Field plus 2-digit add-on Data Field)
PDF                 (Printable Data Field)
STOP                (Ends Bar Code command)
BARCODE              (New Bar Code command)
EAN8+2;VSCAN;H10;DARK;33;55
                    (Vertical Dark EAN 8, 2-digit add-on,
                    H 1.0, SR 33, SC 55)
*123456722*         (Data Field plus 2-digit add-on Data Field)
PDF                 (Printable Data Field)
STOP                (Ends Bar Code command)
END                 (Terminates Create Form mode)
~EXECUTE;EAN8;1     (Execute the form, form count of 1)
    
```



Figure 15. Sample EAN 8 Bar Codes

EAN 13

The EAN 13 bar code structure is shown in Figure 16 and described on the following pages.

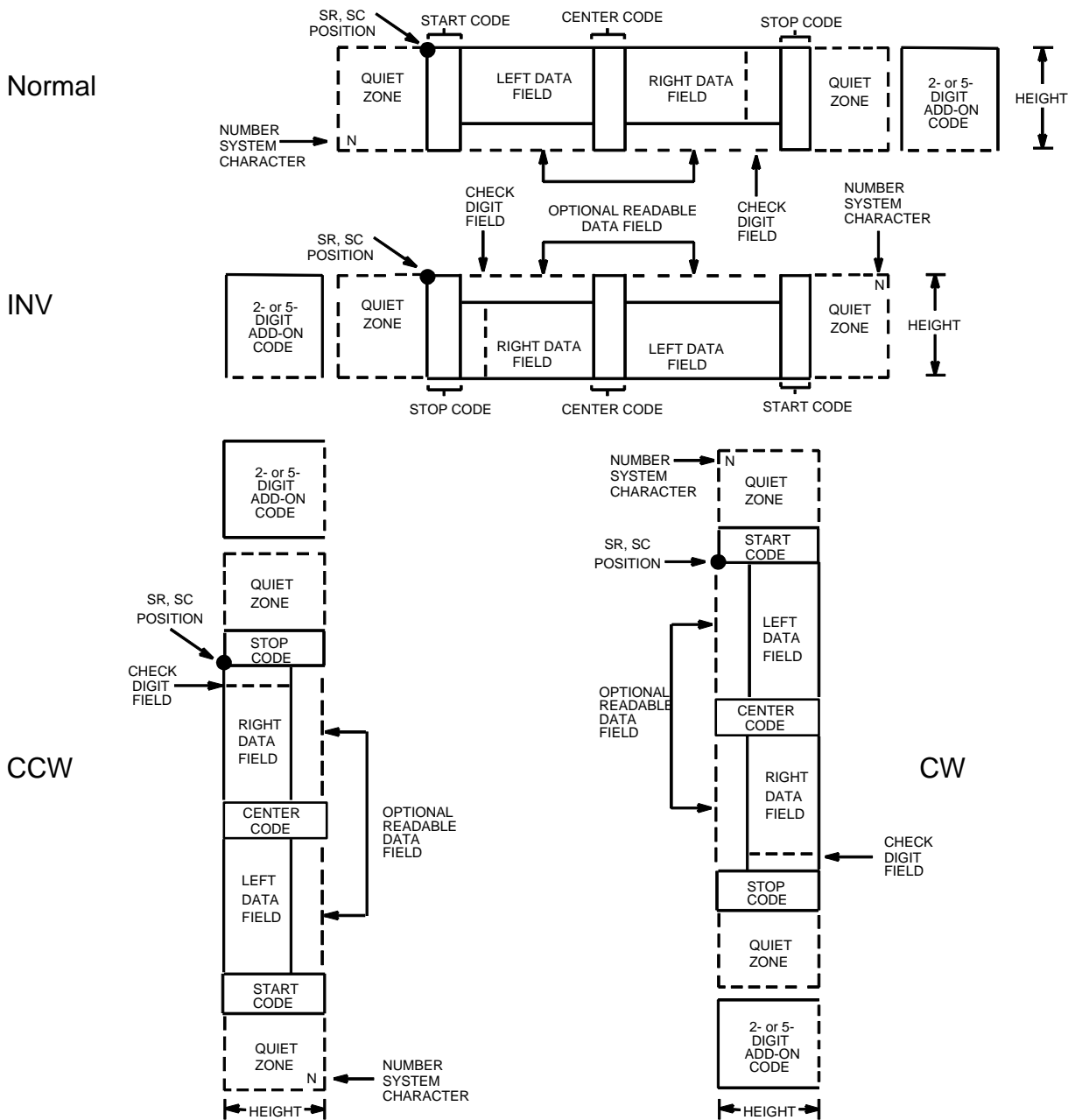

Figure 16. EAN 13 Structure

Quiet Zone

Quiet zones extend on both ends of the bar code to permit the scan to begin and end in a blank area. The IGP automatically produces an 11-module wide left quiet zone; you are responsible for providing sufficient space (minimum of seven modules) on the form for the right quiet zone. The number system character is also printed automatically in the left quiet zone.

Start/Center/Stop Codes

The start/center/stop codes are special character codes marking those portions of the bar code. These codes are automatically provided.

Number System Character

The number system character field allows you to provide a code to a class or type of item. The first character in the data field is used as the number system character.

Data Field

The bar code symbol uses a series of varying width bars and spaces to represent a limited character set (numbers 0-9 and Special Characters Start, Center, and Stop). The bars and spaces vary in width from one to four modules. Each character consists of two bars and two spaces that total seven modules. The symbol coding of the left data field is different from the right data field to permit read direction sensing.

The optional 2- or 5-digit add-on data field is placed at the end of the bar code data and typically identifies a periodical issue number or price, respectively.

Readable Data

The human readable data field provides a readable interpretation of the bar code data. It can either be suppressed or printed above or below the bar code symbol.

Check Digit

The modulo-10 check digit is automatically calculated and inserted in the bar code symbol. The check digit verifies accurate scanning. The number system character is included in the check digit algorithm.

EAN 13 Command Format

BARCODE

EAN13 [+n];[DIR];[SCB];[MAG];[Hn[.m)];[BFn];[DARK];SR;SC
[(D)data field(D)]

[PDF [;LOC] [;FONT]]

STOP

BARCODE The Bar Code command; enter **BARCODE**.

EAN13 Designates bar code type EAN 13; enter **EAN13**.

+n Optional parameter to provide a 2- or 5-digit add-on code at the end of the bar code data field. Enter a plus sign (+) and a value of **2** or **5**. The first bar of the add-on code is separated by nine modules from the last bar of the EAN symbol and a left guard pattern. No center or right guard pattern exists.

DIR Optional parameter that allows for rotating a barcode. Enter **CW** for clockwise rotation. Enter **CCW** or **VSCAN** for counter-clockwise rotation. Enter **INV** for inverted rotation. If *DIR* is not entered, the barcode is horizontally oriented.

SCB This option shortens the length of the center guard bars, which are normally full length.

MAG Optional parameter to magnify (horizontally expand) the bar code symbol. The magnification default value is **X1**. Increasing the magnification adjusts printed character density as shown in Table 8. You can also use XR or XRD as defined on page 89. (You must specify 8 digits for MAG for variable ratio.)

Hn[.m] Optional parameter to adjust the overall height (vertical expansion) of the bar code symbol (including the upper and lower 0.1-inch guard bands and any human readable data). Height adjustments are made in 0.1-inch increments; enter **H** and a value from **4** through **99** to select height adjustments from 0.4 through 9.9 inches. The default value is 1.3 inches. The [.m] provides an additional number of dots for the bar code height. (Dots are in the current dot scale.)

BFn Optional parameter for assigning a dynamic bar code data field location on a form. With this parameter, the actual data for the bar code data field is dynamically provided during the Execute Form mode; the data is not specified during the Create Form mode. To use this field, perform the following steps:

- a. Enter **BF**.

- b. Replace *n* with a number ranging from 1 through 512 to identify the bar code field. The *SR* and *SC* parameters specify the exact location of the bar code field identified by *n*.
- c. The length of the data field need not be specified, since it is fixed at 12 digits, plus any add-on data.
- d. The information for the data field is entered dynamically during the Execute Form mode. (Refer to “Execute Form: Dynamic Bar Code Data” on page 63.) Do not use the *data field* parameter to enter data when the *BFn* parameters are used. However, refer to the *data field* description for available characters.

DARK	Optional parameter to produce darker bar codes. Enter DARK . Refer to “Dark Printing” on page 28 for more information.
<i>SR</i>	Defines the starting row for the bar code. Enter a value ranging from row 1 to one less than the length of the form. Character row or dot row is specified based on the Scale command (page 83), or use the CP.DP format (page 26).
<i>SC</i>	Defines the starting column of the bar code. Enter a value ranging from column 1 to one less than the width of the form. Character column or dot column is specified based on the Scale command (page 83), or use the CP.DP format (page 26).
(D)	The printable character (delimiter) identifying the start and finish of the data field. Enter any printable character other than a slash (/), the SFCC, or a character used within the data. The same character must be used at both ends of the data field, but it is not printed with the data.
<i>data field</i>	Enter the characters of the bar code data, restricted to exactly 12 digits. If the 2- or 5-digit add-on data option is used, include this data at the end of the data field. The characters available for the data field are 0 through 9 (30 through 39 hex, respectively). The first character is interpreted as the number system character.

The left side of the data field (or the lower side on vertically-oriented symbols) can be encoded in either format A or format B as determined by the value of the number system character. (A bar code character is not produced for the number system character.) The number system character is derived from the left side data field encoding. The right side of the data field (or the upper side on vertically-oriented symbols) and check digit are

always encoded in format C. Table 15 defines the left side data field format based on the number system character.

- PDF Optional parameter which affects printing of the human readable data field. The data field will print automatically in the default OCR-B font unless the PDF-suppress command is specified in the *FONT* parameter. The human readable data field can be printed above or below the bar code symbol.

- LOC Optional parameter to identify the location of the printable data field. The default value is **B**, locating the human readable data below the bar code. **A** locates the printable data field above the bar code. To compensate for printing the 0.1-inch high data, the height of the bar code body is reduced 0.1 inch.

- FONT Optional parameter to select the font for the human readable data field. Enter **O** to select OCR-A font; enter **X** to select OCR-B font; enter **N** to select 10 cpi; enter **P** to select 12 cpi; enter **Q** to select 13 cpi; enter **R** to select 15 cpi; enter **T** to select 17 cpi; enter **V** to select 20 cpi. Enter **S** to suppress printing the data field and the trailing lower portions of the EAN bar code.

- STOP Ends the Bar Code command while the IGP continues in the Create Form mode. Enter **STOP**. If STOP is not entered, an error message results.

Table 15. Left Side Data Field Format

Number System Character Value	Format for Left Side Data Field Positions					
	12	11	10	9	8	7
0	A	A	A	A	A	A
1	A	A	B	A	B	B
2	A	A	B	B	A	B
3	A	A	B	B	B	A
4	A	B	A	A	B	B
5	A	B	B	A	A	B
6	A	B	B	B	A	A
7	A	B	A	B	A	B
8	A	B	A	B	B	A
9	A	B	B	A	B	A

EAN 13 Example

Figure 17 illustrates a horizontal and vertical EAN 13 bar code generated by the following program:

```

~CREATE;EAN13
BARCODE
EAN13+5;D;28;15
*12345678987655555*
PDF
STOP
/
BARCODE
EAN13+5;VSCAN;H12;D;27;49
*12345678987655555*
PDF
STOP
END
~EXECUTE;EAN13;1

~NORMAL
    
```



Figure 17. Sample EAN 13 Bar Codes

FIM

The FIM (Facing Identification Mark) bar code structure is shown in Figure 18 and Figure 19 and described on the following pages. The left boundary must begin 3 inches from the right edge of the mail piece. The right-most bar must be 2 inches \pm 1/8-inch from the right edge of the mail piece. Bars must be 5/8-inch \pm 1/8-inch tall; the top of the bars must be no lower than 1/8-inch from the top edge of the mail piece (and may touch the top edge of the mail piece). The bar code baseline must be within 1/8-inch from the bottom edge of the clear zone.

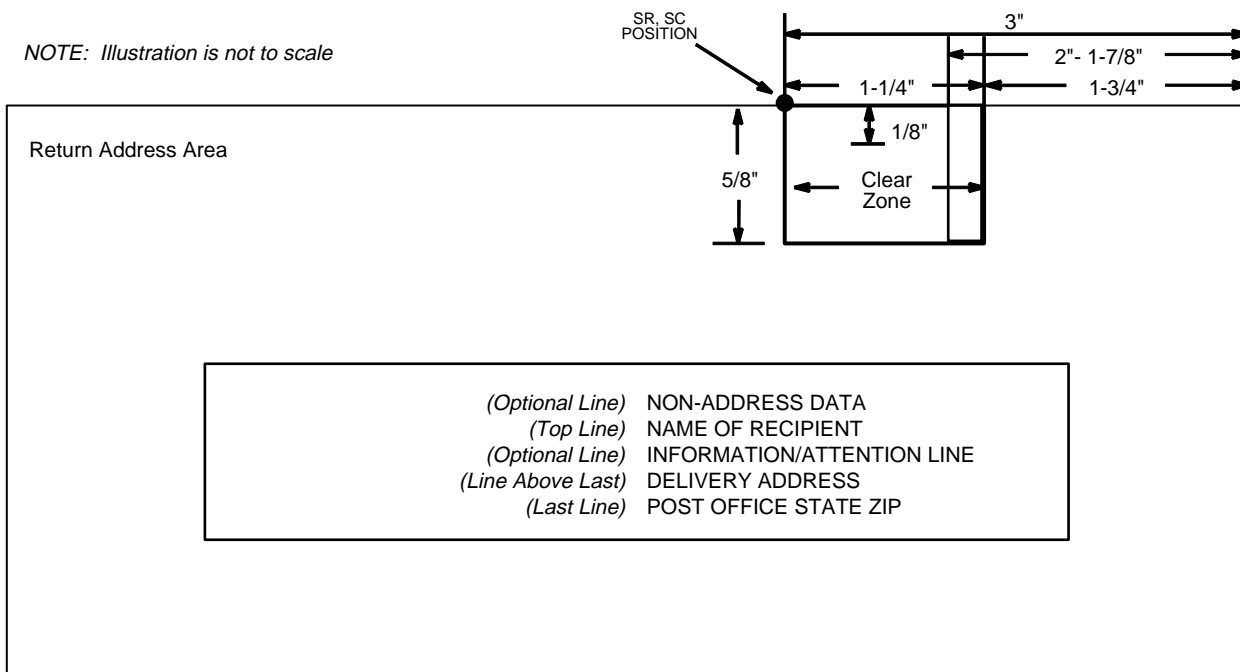

Figure 18. FIM Structure

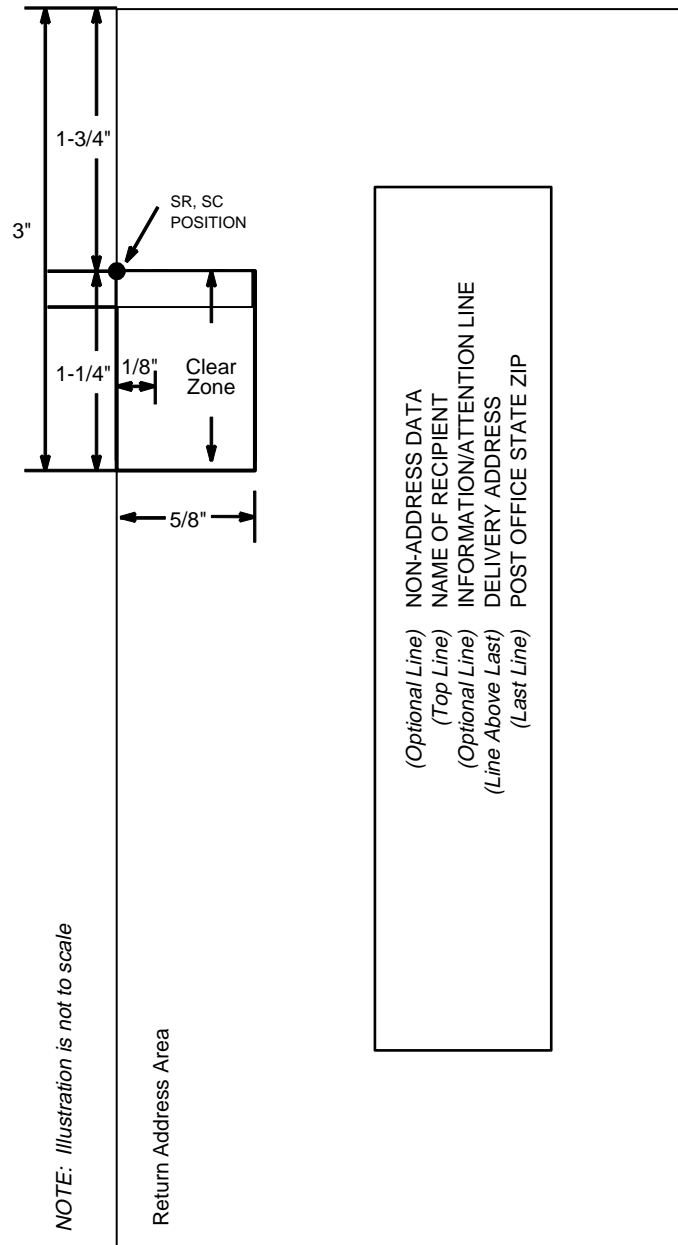

Figure 19. FIM Structure (VSCAN or CCW)

Note



Additional information regarding FIM bar code requirements can be obtained from the U.S. Postal Service's Publication 25: *A Guide to Business Mail Preparation*.

Clear Zone

The bar code structure requires a completely blank, 1/4-inch wide, 5/8-inch tall clear zone, reserved for only the appropriate FIM pattern. You must provide sufficient space for this zone.

Start/Stop Code

The start/stop code is a unique character identifying the leading and trailing end of the bar code. The start/stop code is automatically produced with each bar code. The start/stop code structure permits bidirectional bar code scanning.

Data Field

The bar code symbol uses a nine-position bar/no-bar pattern of tall (full) bars of uniform height. Minimum height must be 5/8-inch \pm 1/8-inch. (Bar height may be longer to wrap around the top of the envelope.) Minimum bar width is .031-inch \pm .008-inch. Spacing (pitch) between each bar/no-bar must be 1/16-inch. Bar tilt (slant) can vary \pm 5 degrees (relative to a line perpendicular to the top edge of the envelope).

FIM Command Format

```
BARCODE
FIM; [DIR;] [Hn[.m];] [BFn;] [DARK;] SR; SC
[(D)data field(D)]
STOP
```

BARCODE The Bar Code command; enter **BARCODE**.

FIM Designates bar code type FIM; enter **FIM**.

DIR Optional parameter that allows for rotating a barcode. Enter **CW** for clockwise rotation. Enter **CCW** or **VSCAN** for counter-clockwise rotation. Enter **INV** for inverted rotation. If *DIR* is not entered, the barcode is horizontally oriented.

Hn[.m] Optional parameter to adjust the overall height (vertical expansion) of the bar code symbol (including the upper and lower 0.1-inch guard bands and any human readable data). Height adjustments are made in 0.1-inch increments; enter **H** and a value from **6** through **99** to select height adjustments from 0.6 to 9.9 inches. The default value is 0.6 inches.
[.m] is an additional number of dots for the bar code height. (Dots are in the current dot scale.)

BFn Optional parameter for assigning a dynamic bar code data field location on a form. With this parameter, the actual data for the bar code data field is dynamically provided during the Execute Form Mode; the data is not specified during the Create Form Mode. To use this field, perform the following steps:

- a. Enter **BF**.
- b. Replace *n* with a number ranging from 1 through **512** to identify the bar code field. The *SR* and *SC* parameters specify the exact location of the bar code field identified by *n*.
- c. The information for the data field is entered dynamically during the Execute Form Mode. (Refer to “Execute Form: Dynamic Bar Code Data” on page 63.) Do not use the *data field* parameter to enter data when the *BFn* parameters are used. Refer to the *data field* description for available characters.

DARK	Optional parameter to produce darker looking bar codes. Enter DARK . Refer to “Dark Printing” on page 28 for more information.
<i>SR</i>	Defines the starting row for the bar code. Enter a value 1/8-inch from the top edge of the mail piece. Character row or dot row is specified based on the Scale command (page 83), or use the CP.DP format (page 26).
<i>SC</i>	Defines the starting column of the bar code. Enter a value ranging from column 1 to one less than the width of the form. Character column or dot column is specified based on the Scale command (page 83), or use the CP.DP format (page 26).
<i>(D)</i>	The printable character (delimiter) identifying the start and finish of the data field. Enter any printable character other than a slash (/), the SFCC, or a character used within the data. The same character must be used at both ends of the data field, but it is not printed with the data.
<i>data field</i>	<p>A single-character data field to designate one of four available FIM patterns: A, B, C, or D. Based on your application (check with your Postal Service for more information), enter one of the following FIM types:</p> <p>A Used only on courtesy reply envelopes bearing a preprinted POSTNET bar code (page 158); it requires a luminescent stamp or meter mark to be accepted in the facer/canceler.</p> <p>B Used on Business Reply Mail, Penalty Mail, and Franked Mail without a preprinted POSTNET bar code, and does not require luminescent indicia.</p> <p>C Used on Business Reply Mail, Penalty Mail, or Franked Mail bearing a preprinted POSTNET bar code (page 158).</p>

D Used on OCR readable mail (usually courtesy reply window envelopes) without a preprinted POSTNET bar code.

STOP Ends the Bar Code command while the IGP/PGL continues in the Create Form Mode. Enter **STOP**. If **STOP** is not entered, an error message results.

FIM Example

Figure 20 below illustrates a horizontal FIMB bar code generated by the following program without the POSTNET preprinted bar code (POSTNET is discussed on page 158.)

```

~CREATE;FIMB                (Enter Create Form Mode)
ALPHA                       (Alpha command)
23;11;0;0;*PRINTRONIX, INC.*
25;11;0;0;*ATTN: CUSTOMER SERVICE*
27;11;0;0;*P.O. BOX 19559*
29;11;0;0;*IRVINE, CA 92714-9559*
STOP                        (Ends Alpha command)
BARCODE                     (Bar Code command)
FIM;DARK;15;22              (Dark FIM Bar Code at SR 15, SC 22)
*B*                         (Data field selecting FIMB Bar Code)
STOP                        (Ends FIMB Bar Code command)
END                         (Terminates Create Form Mode)
~EXECUTE;FIMB;1            (Executes the form, form count of 1)

```

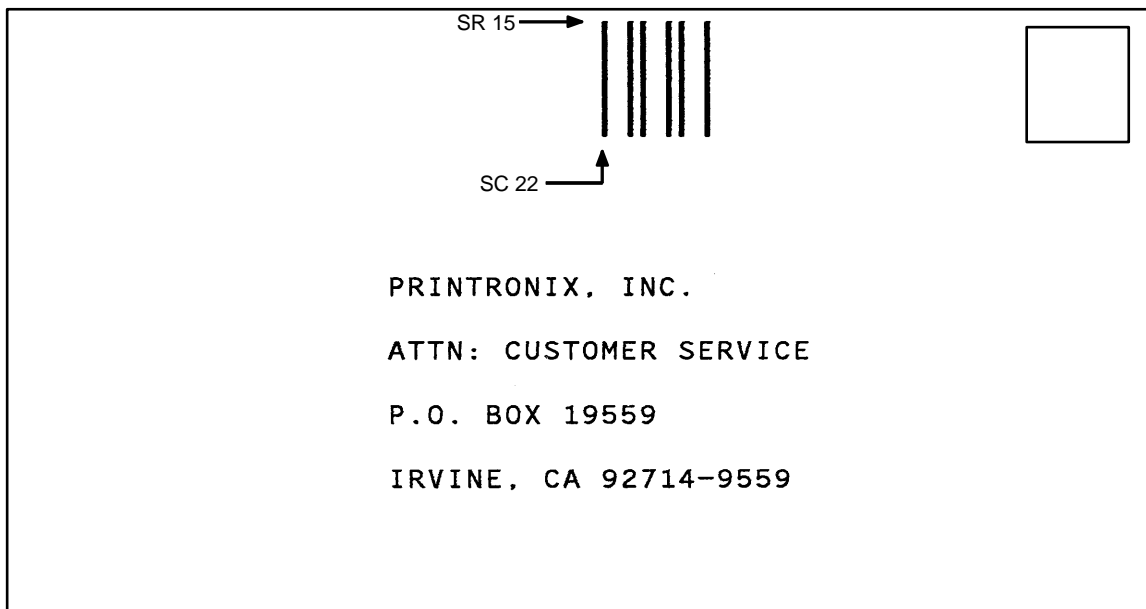

Figure 20. Sample FIMB Bar Code

Figure 21 illustrates a horizontal FIMC bar code generated by the following program and bears the preprinted POSTNET bar code.

```

~CREATE;FIMC          (Enter Create Form Mode)
ALPHA                 (Alpha command)
23;11;0;0;*PRINTRONIX, INC.*
25;11;0;0;*ATTN: CUSTOMER SERVICE*
27;11;0;0;*P.O. BOX 19559*
29;11;0;0;*IRVINE, CA 92714-9559*
STOP                  (Ends Alpha command)
BARCODE               (Bar Code command)
FIM;DARK;17;25       (Dark FIM Bar Code at SR 17, SC 25)
*C*                   (Data field selecting FIMC Bar Code)
STOP                  (Ends Bar Code command)
BARCODE               (New Bar Code command)
POSTNET;DARK;33.3;15 (Dark POSTNET Bar Code at SR 33.3, SC 15)
*927149559*          (POSTNET data field)
STOP                  (Ends POSTNET Bar Code command)
END                   (Terminates Create Form Mode)
~EXECUTE;FIMC;1      (Executes the form, form count of 1)

```

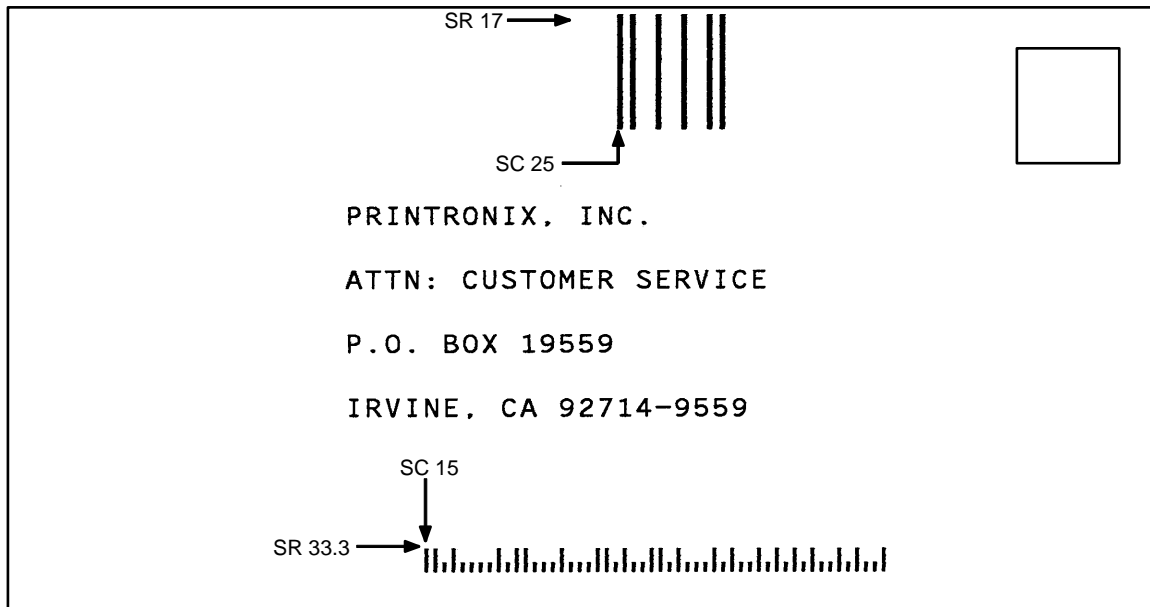

Figure 21. Sample FIMC Bar Code

Interleaved 2/5 (I-2/5), German I-2/5 and ITF-14

The Interleaved 2/5, German I-2/5 and ITF-14 bar code structure is shown in Figure 22 and described on the following pages.

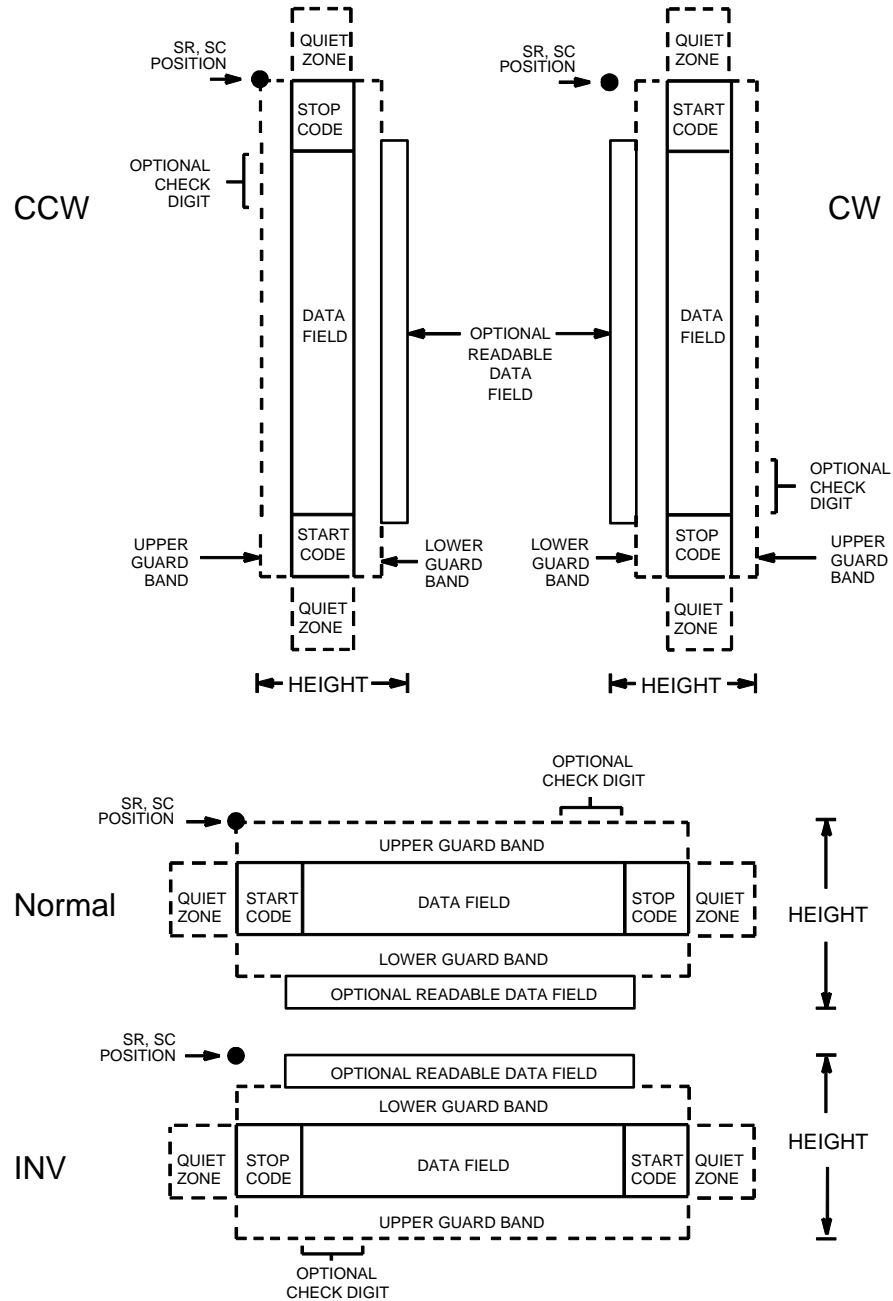

Figure 22. Interleaved 2/5, German I-2/5 and ITF-14 Structure

Quiet Zone

Both ends of the bar code structure have blank quiet zones. The quiet zones must be at least 0.25 inches wide and completely blank to ensure accurate reading of the start/stop codes and to prevent adjacent bar codes from overlapping. You must provide sufficient space on the form for the quiet zones.

Start/Stop Codes

Unique start and stop codes permit bidirectional scanning. Both start and stop codes contain bars and spaces. They are automatically produced.

Data Field

The bar code symbol uses a series of wide and narrow bars and spaces to represent numeric characters. The structure is 2 wide elements (bars or spaces) and 3 narrow elements. In the bar code, two characters are interleaved (paired); bars are used to represent the first character in the pair and spaces are used to represent the second character in the pair.

German I-2/5 and ITF-14 are special cases of Interleaved 2/5 bar codes. While Interleaved 2/5 has a variable data field, German I-2/5 is restricted to 11 or 13 digits, and ITF-14 is restricted to 13 digits.

Readable Data

The optional readable data field provides a readable interpretation of the bar code data. It can be printed above or below the bar code symbol.

Check Digit

The modulo-10 check digit can be inserted into the bar code to verify accurate scanning.

Interleaved 2/5 can be printed with or without a check digit, but German I-2/5 and ITF-14 have the check digit automatically included.

I-2/5 Command Format

BARCODE	
I-2/5 [CD]; or	
I25GERMAN; or	
ITF14; [DIR;] [MAG;] [Hn[.m];] [BFn;L;] [DARK;] SR; SC	
[(D)data field(D)]	
[PDF [;LOC] [;FONT]]	
STOP	
BARCODE	The Bar Code command; enter BARCODE .
I-2/5 CD	Designates bar code type Interleaved 2/5; enter I-2/5 . To calculate and plot the optional modulo-10 check digit with the bar code symbol automatically, enter CD .
I25GERMAN	Designates German Interleaved 2/5; enter I25GERMAN . The mod-10 check digit is automatically included.
ITF14	Designates ITF-14; enter ITF14 . The mod-10 check digit is automatically included.
DIR	Optional parameter that allows for rotating a barcode. Enter CW for clockwise rotation. Enter CCW or VSCAN for counter-clockwise rotation. Enter INV for inverted rotation. If <i>DIR</i> is not entered, the barcode is horizontally oriented.
MAG	Optional parameter to magnify (horizontally expand) the bar code symbol. The magnification default value is X1 . As required for scanning, enter a magnification value from Table 8 to increase the magnification. Increasing the magnification adjusts printed character density. You can also use XR or XRD as defined on page 89.
Hn[.m]	Optional parameter to adjust the overall height (vertical expansion) of the bar code symbol (including the upper and lower 0.1-inch guard bands and any human readable data). Height adjustments are made in 0.1-inch increments; enter H and a value from 3 through 99 to select height adjustments from 0.3 through 9.9 inches. The default value is 0.9-inch. The [.m] provides an additional number of dots for the bar code height. (Dots are in the current dot scale.)

Note



If 0.3 inches is the selected height, the PDF cannot be included.

<i>BFn;L</i>	<p>Optional parameters for assigning a dynamic bar code data field location on a form and for designating the length of the data field. With these parameters, the actual data for the bar code data field is provided dynamically during the Execute Form mode; the data is not specified during the Create Form mode. To use this field, perform the following steps:</p> <ol style="list-style-type: none">Enter BF.Replace <i>n</i> with a number ranging from 1 through 512 to identify the bar code field. The <i>SR</i> and <i>SC</i> parameters specify the exact location of the bar code field identified by <i>n</i>.Replace <i>L</i> with a number equaling the total number of characters in the field. (The actual data provided dynamically during the Execute Form mode can be less than <i>L</i>.)The information for the data field is entered dynamically during the Execute Form mode. (Refer to “Execute Form: Dynamic Bar Code Data” on page 63.) Do not use the <i>data field</i> parameter to enter data when the <i>BFn;L</i> parameters are used. However, refer to the <i>data field</i> description for available characters.
DARK	<p>Optional parameter to produce darker bar codes. Enter DARK. Refer to “Dark Printing” on page 28 for more information.</p>
<i>SR</i>	<p>Defines the starting row for the bar code. Enter a value ranging from row 1 to one less than the length of the form. Character row or dot row is specified based on the Scale command (page 83), or use the CP.DP format (page 26).</p>
<i>SC</i>	<p>Defines the starting column of the bar code. Enter a value ranging from column 1 to one less than the width of the form. Character column or dot column is specified based on the Scale command (page 83), or use the CP.DP format (page 26).</p>
(<i>D</i>)	<p>The printable character (delimiter) identifying the start and finish of the data field. Enter any printable character other than a slash (/), the SFCC, or a character used within the data. The same character must be used at both ends of the data field, but it will not print with the data.</p>

<i>data field</i>	<p>Interleaved 2/5: Enter the characters for the bar code data. A null data field (no characters) is permitted. The length of the data field is variable; however, the maximum length is usually limited to 32 characters to minimize potential reading errors. An even number of characters are required for the interleaving process. Consequently, if an odd number of characters are entered in the data field, a leading zero is added automatically. The characters available for the data field are 0 through 9 (30 through 39 hex, respectively).</p> <p>German I-2/5: The data field must be 11 or 13 digits exactly.</p> <p>ITF-14: The data field must be 13 digits exactly.</p>
PDF	Optional parameter to enable printing of the human readable data field. Enter PDF to print the data field. If the parameter is not used, the human readable data is not printed. This parameter is not allowed if a null data field was specified. For German I-2/5, fields of the data are separated by dots and spaces.
LOC	Optional parameter to identify the location of the printable data field. The default value is B , locating the human readable data below the bar code. A locates the printable data field above the bar code. To compensate for printing the 0.1-inch high data, the height of the bar code body is reduced 0.1-inch.
FONT	Optional parameter to select the font for the human readable data field. Enter O to select OCR-A font; enter X to select OCR-B font; enter N to select 10 cpi; enter P to select 12 cpi; enter Q to select 13 cpi; enter R to select 15 cpi; enter T to select 17 cpi; enter V to select 20 cpi.
STOP	Ends the Bar Code command while the IGP continues in the Create Form mode. Enter STOP . If STOP is not entered, an error message results.

I-2/5 Example

Figure 23 illustrates a horizontal and vertical I-2/5 bar code generated by the following program:

```

~CREATE;I25          (Enter Create Form mode)
BARCODE             (Bar Code command)
I-2/5;DARK;49;27   (Dark Code I-2/5, at SR 49, SC 27)
*24688642*         (Data Field)
PDF;A              (Upper Printable Data Field)
STOP               (Ends Bar Code command)
BARCODE            (New Bar Code command)
I-2/5;VSCAN;H12;DARK;44;52
                  (Vert. Dark I-2/5, H 1.2 at SR 44, SC 52)
*24688642*         (Data Field)
PDF                (Printable Data Field)
STOP              (Ends Bar Code command)
END               (Terminates Create Form mode)
~EXECUTE;I25;1     (Execute the form, form count of 1)

```

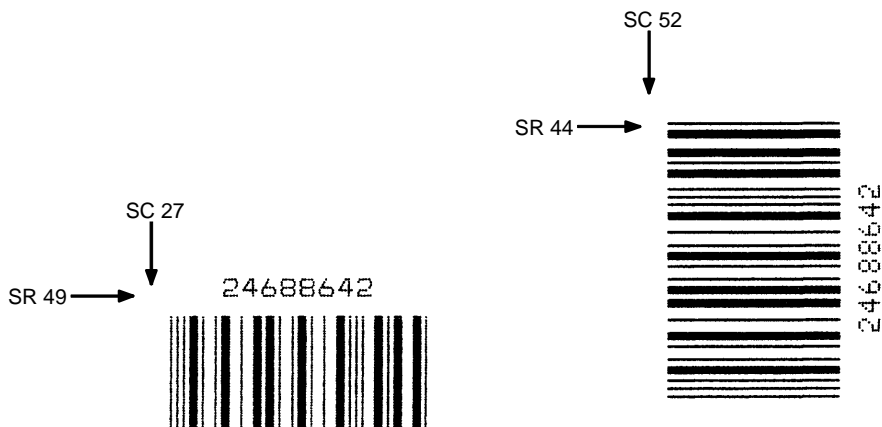

Figure 23. Sample I-2/5 Bar Codes

Matrix

The structure for the Matrix bar code is shown in Figure 24 and described on the following pages.

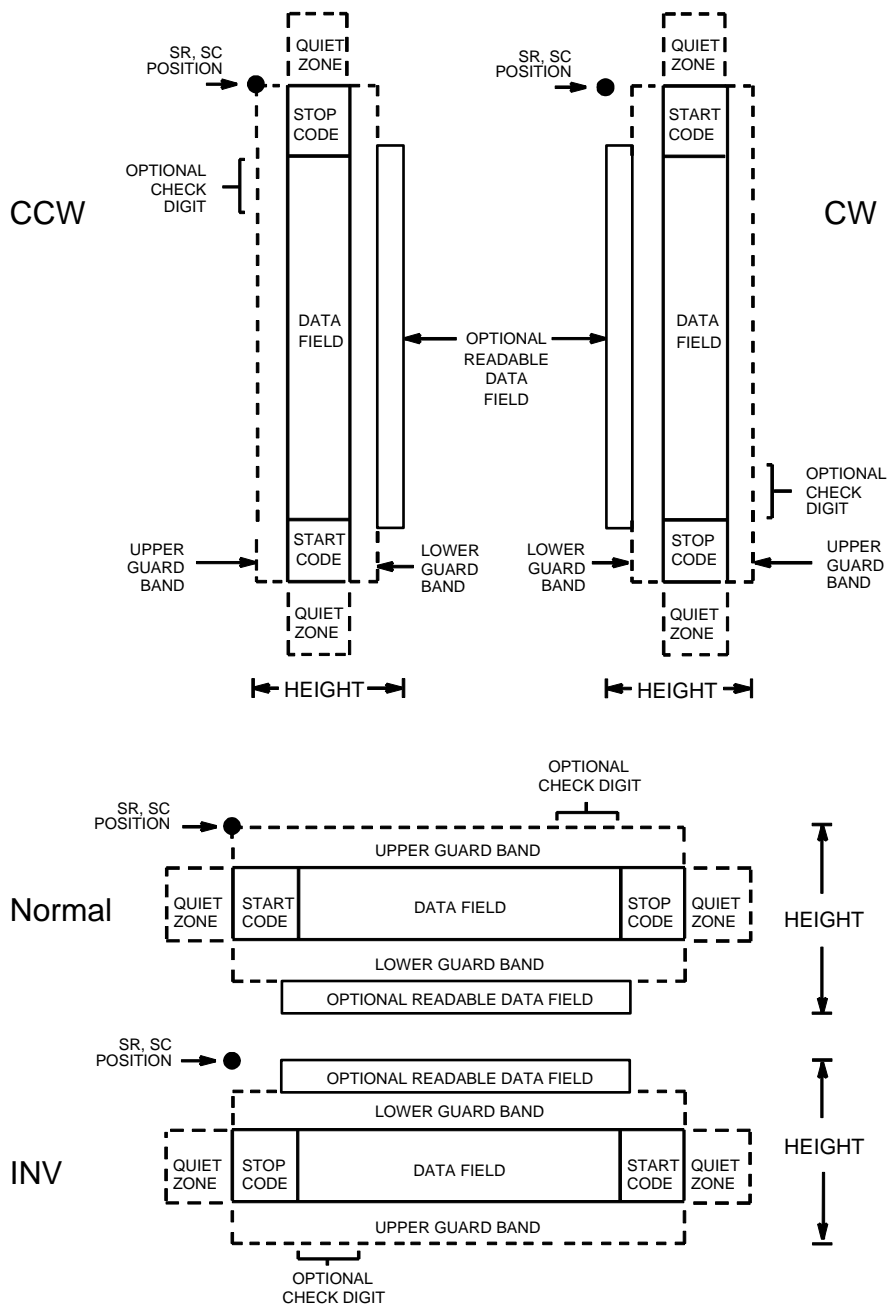

Figure 24. Matrix Structure

Quiet Zone

Both ends of the bar code structure have blank quiet zones. The quiet zones must be at least 0.25 inches wide and completely blank to ensure accurate reading of the start/stop codes and to prevent adjacent bar codes from overlapping. You must provide sufficient space on the form for quiet zones.

Start/Stop Codes

Unique start and stop codes permit bidirectional scanning. Both start and stop codes contain bars and spaces. They are automatically produced.

Data Field

The bar code symbol uses a series of wide and narrow bars and spaces to represent numeric characters. The structure is 2 wide elements (bars or spaces) and 3 narrow elements. In the bar code, each character encoded is separated by a narrow space.

Readable Data

The optional readable data field provides a readable interpretation of the bar code data. It can be printed above or below the bar code symbol.

Check Digit

The modulo-10 check digit can be inserted into the bar code to verify accurate scanning.

Matrix Command Format

BARCODE
 MATRIX [CD]; [DIR;] [MAG;] [Hn[.m];] [BFn;L;] [DARK;] SR; SC
 [(D)data field(D)]
 [PDF [;LOC] [;FONT]]
 STOP

BARCODE	The Bar Code command; enter BARCODE .
MATRIX CD	Designates bar code type Matrix; enter MATRIX . To calculate and plot the optional modulo-10 check digit with the bar code symbol automatically, enter CD .
DIR	Optional parameter that allows for rotating a barcode. Enter CW for clockwise rotation. Enter CCW or VSCAN for counter-clockwise rotation. Enter INV for inverted rotation. If <i>DIR</i> is not entered, the barcode is horizontally oriented.
MAG	Optional parameter to magnify (horizontally expand) the bar code symbol. The magnification default value is X1 . As required for scanning, enter a magnification value from Table 8 to increase the magnification. Increasing the magnification adjusts printed character density. You can also use XR or XRD, defined on page 89.
Hn[.m]	Optional parameter to adjust the overall height (vertical expansion) of the bar code symbol (including the upper and lower 0.1-inch guard bands and any human readable data). Height adjustments are made in 0.1-inch increments; enter H and a value from 3 through 99 to select height adjustments from 0.3 through 9.9 inches. The default value is 0.9-inch. [.m] is an additional number of dots for the bar code height. (Dots are in the current dot scale.)

Note



If 0.3 inches is the selected height, the PDF cannot be included.

BFn;L	Optional parameters for assigning a dynamic bar code data field location on a form and for designating the length of the data field. With these parameters, the actual data for the bar code data field is dynamically provided during the Execute Form Mode; the data is not specified during the Create Form Mode. To use this field, perform the following steps: a. Enter BF .
-------	--

- b. Replace *n* with a number ranging from 1 through 512 to identify the bar code field. The *SR* and *SC* parameters specify the exact location of the bar code field identified by *n*.
- c. Replace *L* with a number equaling the total number of characters in the field. (The actual data provided dynamically during the Execute Form Mode can be less than *L*.)
- d. The information for the data field is entered dynamically during the Execute Form Mode. (Refer to “Execute Form: Dynamic Bar Code Data” on page 63.) Do not use the *data field* parameter to enter data when the *BFn;L* parameters are used. However, refer to the *data field* description for available characters.

DARK	Optional parameter to produce darker looking bar codes. Enter DARK . Refer to “Dark Printing” on page 28 for more information.
<i>SR</i>	Defines the starting row for the bar code. Enter a value ranging from row 1 to one less than the length of the form. Character row or dot row is specified based on the Scale command (page 83), or use the CP.DP format (page 26).
<i>SC</i>	Defines the starting column of the bar code. Enter a value ranging from column 1 to one less than the width of the form. Character column or dot column is specified based on the Scale command (page 83), or use the CP.DP format (page 26).
(<i>D</i>)	The printable character (delimiter) identifying the start and finish of the data field. Enter any printable character other than a slash (/), the SFCC, or a character used within the data. The same character must be used at both ends of the data field, but it will not print with the data.
<i>data field</i>	Enter the characters for the bar code data. A null data field (no characters) is permitted. The length of the data field is variable; however, the maximum length is usually limited to 32 characters to minimize potential reading errors. An even number of characters are required for the interleaving process. Consequently, if an odd number of characters are entered in the data field, a leading zero is added automatically. The characters available for the data field are 0 through 9 (30 through 39 hex, respectively).

PDF	Optional parameter to enable printing of the human readable data field. Enter PDF to print the data field. If the parameter is not used, the human readable data is not printed. This parameter is not allowed if a null data field was specified.
LOC	Optional parameter to identify the location of the printable data field. The default value is B , locating the human readable data below the bar code. A locates the printable data field above bar code. To compensate for printing the 0.1-inch high data, the height of the bar code body is reduced 0.1-inch.
FONT	Optional parameter to select the font for the human readable data field. Enter O to select OCR-A font; enter X to select OCR-B font; enter N to select 10 cpi; enter P to select 12 cpi; enter Q to select 13 cpi; enter R to select 15 cpi; enter T to select 17 cpi; enter V to select 20 cpi.
STOP	Ends the Bar Code command while the IGP/PGL continues in the Create Form Mode. Enter STOP . If STOP is not entered, an error message results.

Matrix Example

Figure 25 illustrates a horizontal and vertical Matrix bar code generated by the following program:

```

~CREATE;MATRIX           (Enter Create Form Mode)
BARCODE                 (Bar Code command)
MATRIX;DARK;27;49      (Dark Code Matrix, at SR 27, SC 49)
*24688642*             (Data Field)
PDF                    (Printable Data Field)
STOP                   (Ends Bar Code command)
BARCODE                (New Bar Code command)
MATRIX;VSCAN;H1.2;DARK;52;54
                        (Vertical Dark Matrix, H 1.2
                        at SR 52, SC 54)
*24688642*             (Data Field)
PDF                    (Printable Data Field)
STOP                   (Ends Bar Code command)
END                    (Terminates Create Form Mode)
~EXECUTE;MATRIX;1      (Execute the form, form count of 1)
    
```

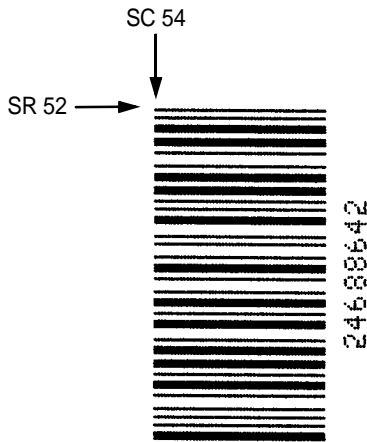

Figure 25. Sample Matrix Bar Codes

MSI

The MSI bar code structure is shown in Figure 26 and described on the following pages.

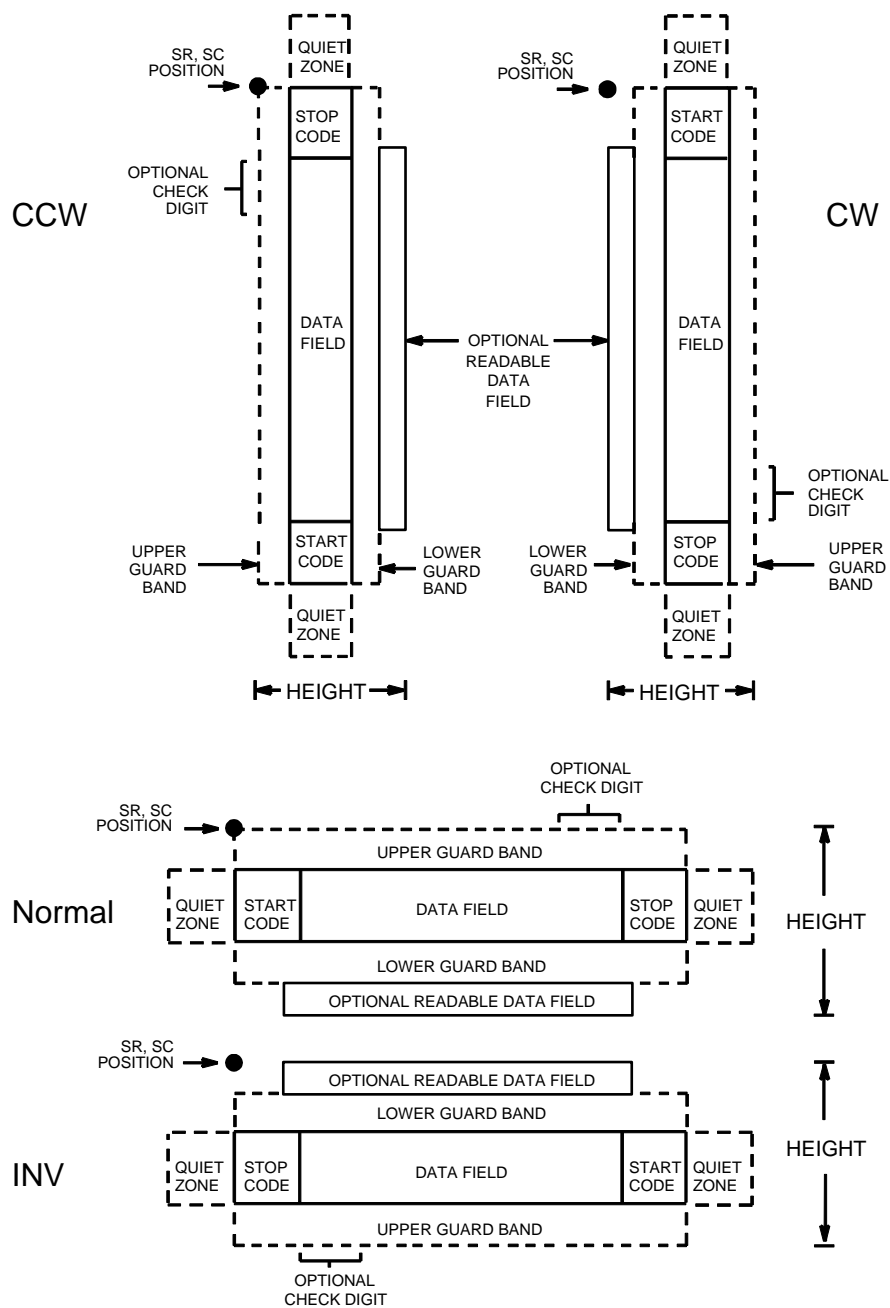

Figure 26. MSI Structure

Quiet Zone

Both ends of the bar code structure require blank quiet zones. The quiet zones must be at least 0.25-inches wide and completely blank to ensure accurate reading of the start/stop codes and to prevent adjacent bar codes from overlapping. You must provide sufficient space on the form for the quiet zones.

Start/Stop Code

Unique start and stop codes permit bidirectional scanning. Both start and stop codes contain bars and spaces. They are automatically produced.

Data Field

The bar code symbol uses a series of wide and narrow bars and spaces to represent each numeric character. The structure is four wide elements (bars or spaces) and four narrow elements. Each character contains four data bits, with each 0-bit made up of a narrow bar/wide space arrangement and each 1-bit made up of a wide bar/narrow space arrangement.

Readable Data

The optional readable data field provides a readable interpretation of the bar code data. It can be printed above or below the bar code symbol.

Check Digit

If specified, the modulo-10 or modulo-11 (or both) check digit is automatically calculated and inserted in the bar code symbol. The check digit verifies accurate scanning.

MSI Command Format

BARCODE

MSI *n*; [*DIR*;] [*MAG*;] [*Hn*.[*m*];] [*BFn*;L;] [*DARK*;] *SR*; *SC*

[*(D)*data field(*D*)]

[*PDF* [;L*OC*] [;F*ONT*]]

STOP

BARCODE The Bar Code command; enter **BARCODE**.

MSI Designates bar code type MSI; enter **MSI**.

n Designates the type of check digit combinations for the bar code. Replace *n* with one of the following codes to specify the check digit.

A single-digit modulo-10 followed by a second modulo-10 digit

B single-digit modulo-11 followed by a single modulo-10 digit

C single-digit modulo-10

D single-digit modulo-11

DIR Optional parameter that allows for rotating a barcode. Enter **CW** for clockwise rotation. Enter **CCW** or **VSCAN** for counter-clockwise rotation. Enter **INV** for inverted rotation. If *DIR* is not entered, the barcode is horizontally oriented.

MAG Optional parameter to magnify (horizontally expand) the bar code symbol. The magnification default value is **X1**. As required for scanning, enter a magnification value from Table 8 to increase the magnification. Increasing the magnification adjusts printed character density. You can also use **XR** or **XRD** as defined on page 89.

Hn.[*m*] Optional parameter to adjust the overall height (vertical expansion) of the bar code symbol (including the upper and lower 0.1-inch guard bands and any human readable data). Height adjustments are made in 0.1-inch increments; enter **H** and a value from **3** through **99** to select height adjustments from 0.3 through 9.9 inches. The default value is 0.9-inch. The [*m*] provides an additional number of dots for the bar code height. (Dots are in the current dot scale.)

Note



If 0.3 inches is the selected height, the PDF cannot be included.

- BF n ;L** Optional parameters for assigning a dynamic bar code data field location on a form and for designating the length of the data field. With these parameters, the actual data for the bar code data field is dynamically provided during the Execute Form mode; the data is not specified during the Create Form mode. To use this field:
- Enter **BF**.
 - Replace n with a number ranging from 1 through **512** to identify the bar code field. The *SR* and *SC* parameters specify the exact location of the bar code field identified by n .
 - Replace L with a number equaling the total number of characters in the field. (The actual data provided dynamically during the Execute Form mode can be less than L .)
 - The information for the data field is entered dynamically during the Execute Form mode. (Refer to "Execute Form: Dynamic Bar Code Data" on page 63.) Do not use the *data field* parameter to enter data when the **BF n ;L** parameters are used. However, refer to the *data field* description for available characters.
- DARK** Optional parameter to produce darker looking bar codes. Enter **DARK**. Refer to "Dark Printing" on page 28 for more information.
- SR** Defines the starting row for the bar code. Enter a value ranging from row 1 to one less than the length of the form. Character row or dot row is specified based on the Scale command (page 83), or use the CP.DP format (page 26).
- SC** Defines the starting column of the bar code. Enter a value ranging from column 1 to one less than the width of the form. Character column or dot column is specified based on the Scale command (page 83), or use the CP.DP format (page 26).
- (D)** The printable character (delimiter) identifying the start and finish of the data field. Enter any printable character other than a slash (/), the SFCC, or a character used within the data. The same character must be used at both ends of the data field, but it will not print with the data.

<i>data field</i>	Enter the characters for the bar code data. A null data field (no characters) is permitted. The length of the data field is variable; however, a maximum of 14 data characters are allowed if a one-character check digit field is specified; a maximum of 13 data characters are allowed if a two-character check digit field is specified. The characters available for the data field are 0 through 9 (30 through 39 hex, respectively).
PDF	Optional parameter to enable printing of the human readable data field. Enter PDF to print the data field. If the parameter is not used, the human readable data will not print.
LOC	Optional parameter to identify the location of the printable data field. The default value is B , locating the human readable data below the bar code. A locates the printable data field above the bar code. To compensate for printing the 0.1-inch high data, the height of the bar code body is reduced 0.1-inch.
FONT	Optional parameter to select the font for the human readable data field. Enter O to select OCR-A font; enter X to select OCR-B font; enter N to select 10 cpi; enter P to select 12 cpi; enter Q to select 13 cpi; enter R to select 15 cpi; enter T to select 17 cpi; enter V to select 20 cpi.
STOP	Ends the Bar Code command while the IGP continues in the Create Form mode. Enter STOP . If STOP is not entered, an error message results.

MSI Example

Figure 27 illustrates a horizontal and vertical MSI bar code generated by the following program:

```

~CREATE;MSI           (Enter Create Form mode)
BARCODE              (Bar Code command)
MSIA;DARK;32;27      (Dark Bar Code MSIA at SR 32, SC 27)
*24688642*           (Data Field)
PDF;X                (Printable Data Field, OCR-B)
STOP                 (Ends Bar Code command)
BARCODE              (New Bar Code command)
MSIB;VSCAN;X2;H12;DARK;32;54
                    (Vert. Dark MSIB, Mag 2, H 1.2 at
                    SR3 2, SC 54)
*24688642*           (Data Field)
PDF;A                (Upper Data Field)
STOP                 (Ends Bar Code command)
END                  (Terminates Create Form mode)
~EXECUTE;MSI;1       (Execute the form, form count of 1)

```

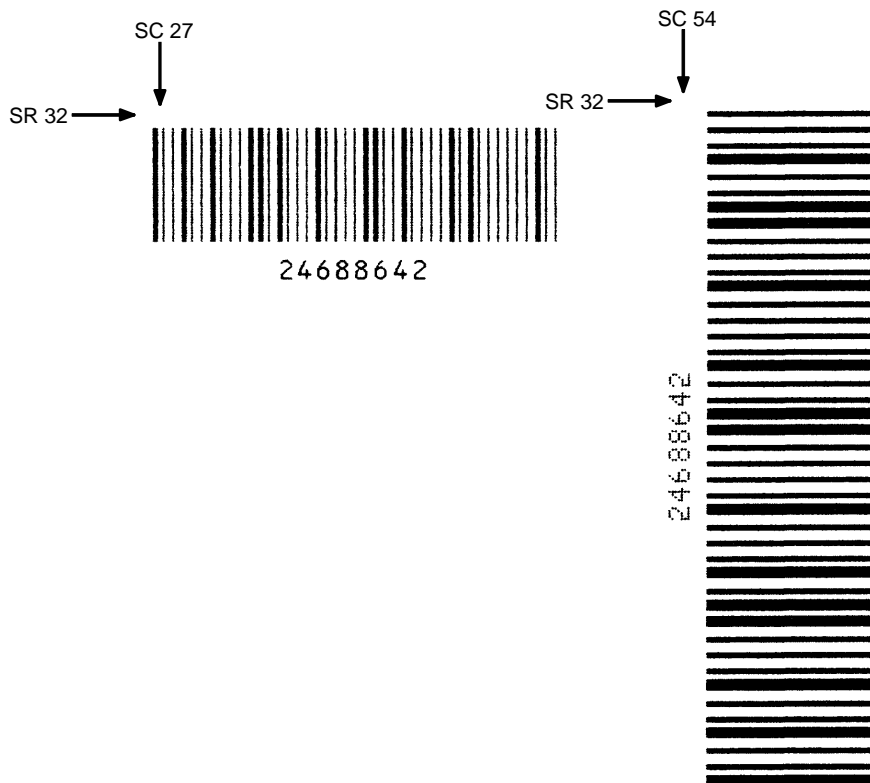

Figure 27. Sample MSI Bar Codes

PDF417

The PDF417 structure is shown in Figure 28 and described on the following pages.

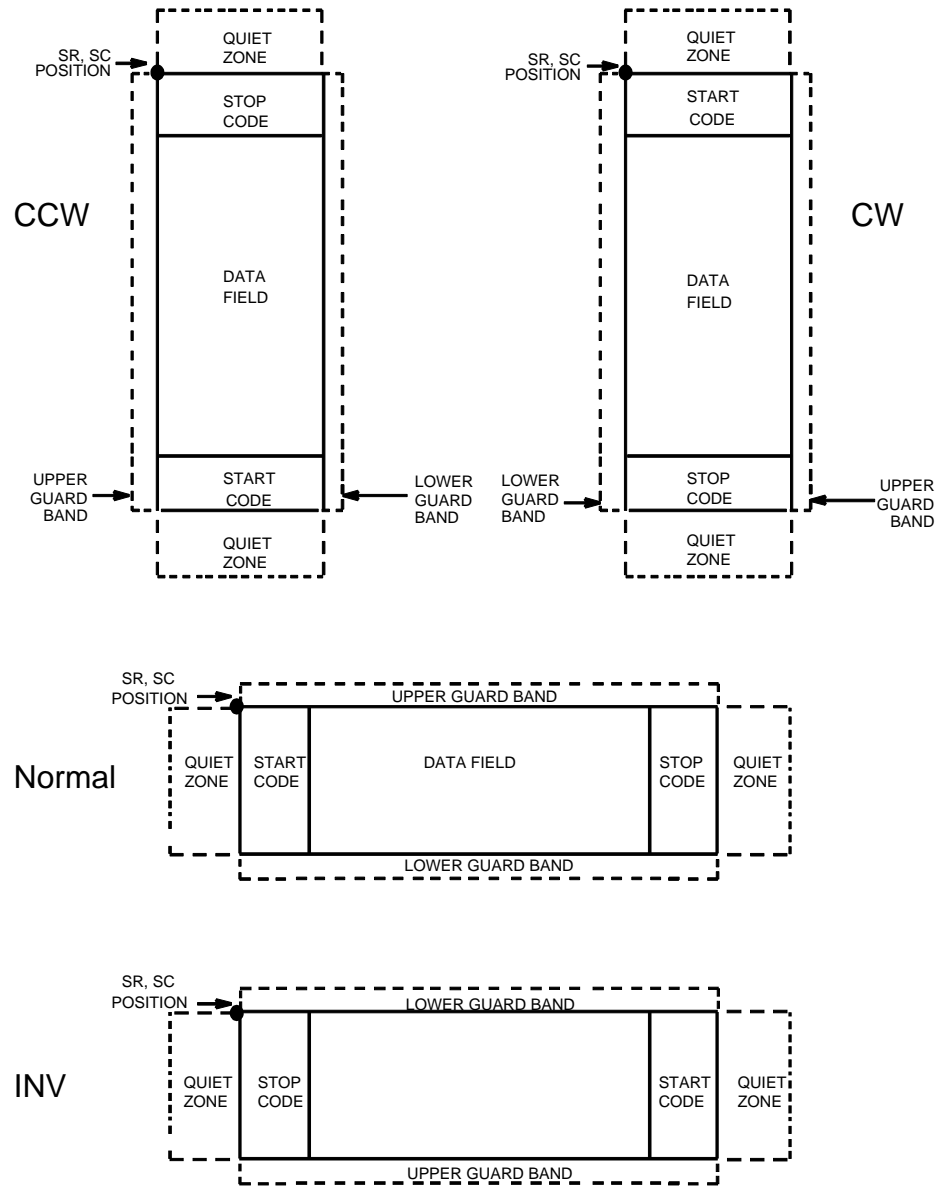

Figure 28. PDF417 Structure

Quiet Zone

Both ends of the bar code structure require blank quiet zones. The quiet zones must be at least 0.25 inches wide and completely blank to ensure accurate reading of the start/stop codes and to prevent adjacent bar codes from overlapping. Be sure to provide sufficient space on the form for the quiet zones.

Start/Stop Codes

The start/stop codes identify the leading and trailing end of the bar code.

Data Field

PDF417 provides twelve modes to encode data. The first three are pre-established (the remaining nine are user modes, which can be defined by users or industry associations according to specific applications):

1. Extended Alphanumeric Compaction mode (EXC). Comprised of four sub-modes, this mode offers encodation of all printable ASCII characters. This is the default mode; the PGL uses shift or latch characters to enable other modes.
2. Binary/ASCII Plus mode. This offers encodation for all ASCII characters, printable or not, and binary values.
3. Numeric Compaction mode. This offers encodation for numeric values to a density of almost 3 digits per code word.
4. The PGL will automatically switch between modes to provide the smallest encodation for the data.

Security Level

PDF417 can detect and correct errors. Each label has 2 code words of error detection. You can select the error correction capacity based on application needs. Specify a security level in the range of 0 - 8, at the time of printing. PDF417 can also recover from omissions and misdecodes of code words. Since it requires two code words to recover from a misdecode, one to detect the error and one to correct for it, a given security level can support half the number of misdecodes that it can of undecoded words.

PDF

Print Data Field is not offered due to the large amount of data that can be encoded.

PDF417 Command Format

BARCODE
 PDF417; [*DIR*]; [*X[D]n*]; [*Y[D]n*]; [*(Hn)| (Wn)*]; [*ASPECTh:w*];
 [*(Rn)|(Cn)*]; [*Sn*]; [*BFn;L*]; [*DARK*]; *SR*; *SC*
 [*(D)data field(D)*]
 STOP

BARCODE	The Bar Code command; enter BARCODE .
PDF417	Designates bar code type PDF417; enter PDF417 .
<i>DIR</i>	Optional parameter that allows for rotating a barcode. Enter CW for clockwise rotation. Enter CCW or VSCAN for counter-clockwise rotation. Enter INV for inverted rotation. If <i>DIR</i> is not entered, the barcode is horizontally oriented.
<i>X[D]n</i>	Optional parameter to designate the width of the narrow element in either the default 60 X 72 dots per inch or, if the D is given, in target dots. The default size is 1/60th of an inch.
<i>Y[D]n</i>	Optional parameter to designate the height of the bar code in either the default 60 X 72 dots per inch or, if the D is given, in target dots. The default size is 2/72nd of an inch.
<i>Hn</i>	Optional parameter to adjust the overall height of the bar code symbol (including human readable data). Height adjustments are made in 0.1-inch increments; enter H and a value from 4 through 99 to select height adjustments from 0.4 through 9.9 inches. Parameters <i>Wn</i> , <i>Rn</i> , <i>Cn</i> or ASPECT cannot be entered if this parameter is used.
<i>Wn</i>	Optional parameter for the maximum width of the symbol based on the narrow element width. Enter Wn ; where <i>n</i> is the overall width in tenths of an inch. Parameters <i>Hn</i> , <i>Rn</i> , <i>Cn</i> or ASPECT cannot be entered if this parameter is used.
ASPECT; <i>h:w</i>	Optional parameter for specifying the symbol height-to-width ratio where <i>h</i> is the height and <i>w</i> is the width, both expressed as integers. The default is 1:2. Parameters <i>Hn</i> , <i>Wn</i> , <i>Rn</i> , or <i>Cn</i> cannot be entered if this parameter is used.
<i>Rn</i>	Optional parameter that specifies the number of rows the symbol will have. Enter R followed by the number of rows in the range of 3 through 90 in multiples of 3. Parameters <i>Hn</i> , <i>Wn</i> , <i>Cn</i> or ASPECT cannot be entered if this parameter is used.
<i>Cn</i>	Optional parameter that specifies the number of columns the symbol will have. Enter C followed by the number of columns in the range of 1 through 90 . Parameters <i>Hn</i> , <i>Wn</i> , <i>Rn</i> or ASPECT cannot be entered if this parameter is used.

<i>Sn</i>	Optional parameter that specifies the security level. Enter S followed by the security level in the range of 0 through 8 . The default is 2.
<i>BFn;L</i>	Optional parameters for assigning a dynamic bar code data field location on a form and for designating the length of the data field. With these parameters, the actual data for the bar code data field is provided dynamically during the Execute Form mode; the data is not specified during the Create Form mode. To use this field, perform the following steps: <ol style="list-style-type: none">Enter BF.Replace <i>n</i> with a number ranging from 1 through 512 to identify the bar code field. The <i>SR</i> and <i>SC</i> parameters specify the exact location of the bar code field identified by <i>n</i>.Replace <i>L</i> with a number equaling the total number of characters in the field. (The actual data provided dynamically during the Execute Form mode can be less than <i>L</i>.)The information for the data field is entered dynamically during the Execute Form mode. (Refer to “Execute Form: Dynamic Bar Code Data” on page 63.) Do not use the <i>data field</i> parameter to enter data when the <i>BFn;L</i> parameters are used. However, refer to the <i>data field</i> description for available characters.
DARK	Optional parameter to produce darker bar codes. Enter DARK . Refer to “Dark Printing” on page 28 for more information.
<i>SR</i>	Defines the starting row for the bar code. Enter a value ranging from row 1 to one less than the length of the form. Character row or dot row is specified based on the Scale command (page 83), or use the CP.DP format (page 26).
<i>SC</i>	Defines the starting column of the bar code. Enter a value ranging from column 1 to one less than the width of the form. Character column or dot column is specified based on the Scale command (page 83), or use the CP.DP format (page 26).
<i>(D)</i>	The printable character (delimiter) identifying the start and finish of the data field. Enter any printable character other than a slash (/), the SFCC, or a character used within the data. The same character must be used at both ends of the data field, but it will not print with the data.

data field Enter the data for the bar code. A null data field (no characters) is not permitted. The data field can contain any character including carriage returns and line feeds. The length of the data field is variable; however, the maximum length is usually limited to 1024 bytes to minimize potential reading errors.

Note

New lines (i.e. carriage returns/line feeds) are allowed in the PDF417 data field and as PDF417 dynamic data field input.

STOP Ends the Bar Code command while the IGP continues in the Create Form mode. Enter **STOP**. If STOP is not entered, an error message results.

PDF417 Example

Figure 29 illustrates a horizontal PDF417 bar code generated by the following program:

```
~CREATE;PDF417
BARCODE
PDF417;X1;Y3;SO;D;37;21;
*ACME MOTOR COMPANY SUPPORTS PRINTING OF PDF417 TWO-DIMENSIONAL
BAR CODE SYMBOLOGY 123456789012345678901234567890123456789*
STOP
END
~EXECUTE;PDF417

~NORMAL
```



Figure 29. Sample PDF417 Bar Codes

POSTNET

The POSTNET bar code structure is illustrated in Figure 30 and Figure 31 and described on the following pages. The POSTNET code can be a part of the address block and appear anywhere within a vertical 4-inch area across the length of the mail piece.

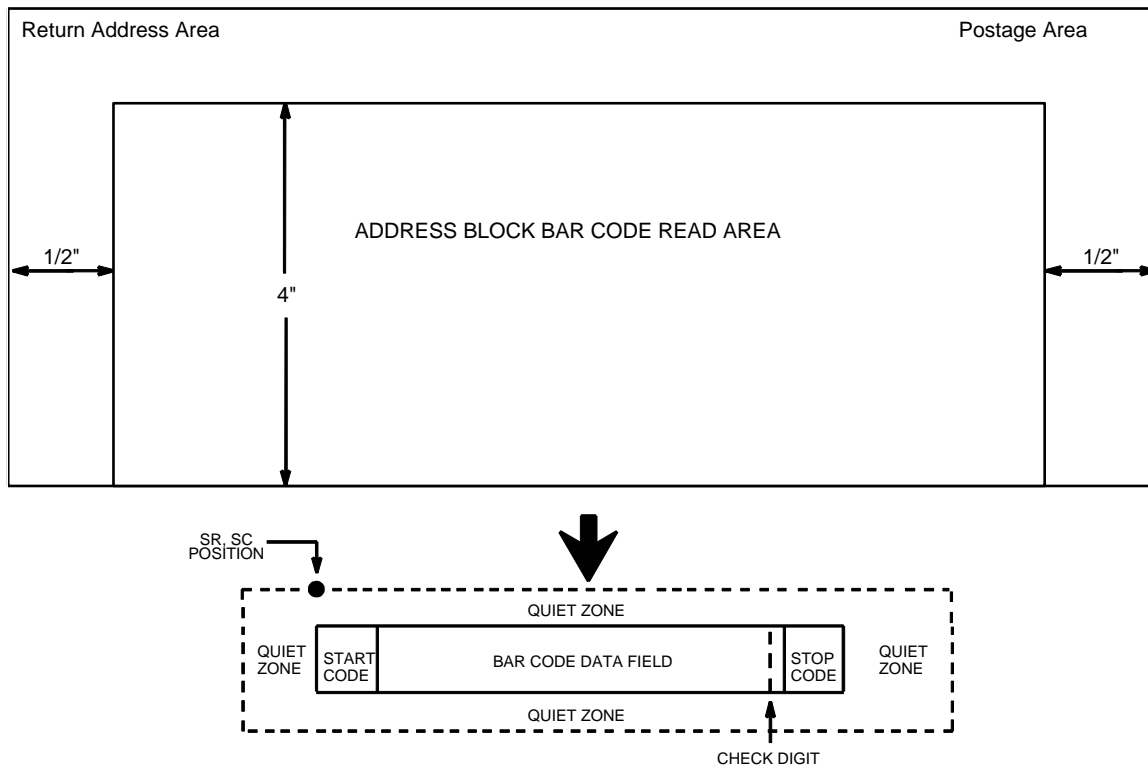

NOTE: Illustration is not to scale

Figure 30. POSTNET Structure

Note



Additional information regarding POSTNET bar code requirements can be obtained from the U.S. Postal Service's Publication 25: *A Guide to Business Mail Preparation*.

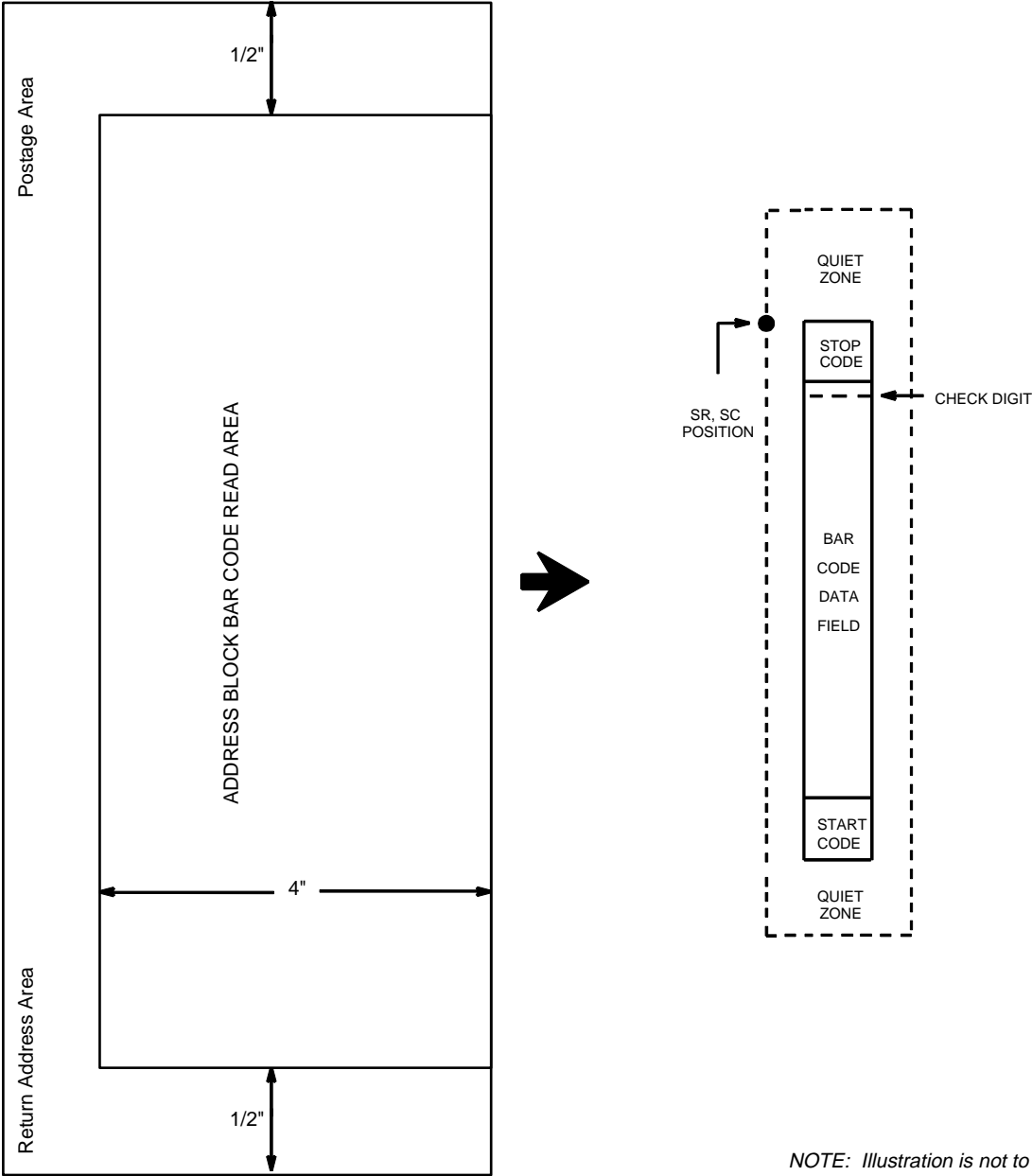

NOTE: Illustration is not to scale

Figure 31. POSTNET Structure (VSCAN or CCW)

Quiet Zone

The bar code structure requires a completely blank quiet zone which extends 4.75 inches from the right edge of the mail piece. In addition, a minimum quiet zone of 0.040-inch above and below the bar code data must also be provided. You must provide sufficient space for this zone.

Start/Stop Code

The start and stop codes are referred to as “framing bars” in POSTNET. The start and stop codes are each one tall bar, one identifying the leading and trailing end of the bar code. The start/stop code is automatically produced with each bar code. The start/stop code structure permits bar code scanning in a left-to right direction only.

Data Field

The bar code data produces a single field of 30 bars for a 5-digit data field, 50 bars for a 9-digit data field, or 60 bars for an 11-digit data field. The bars are grouped in sets of five. Each set of five bars (comprised of two tall bars and three short bars) represents one of the five digits of the zip code, plus the four-digit zip code extension. If the Advanced Bar Code is used, an additional two-digit code is also added to make an 11-digit data field.

Each bar width is equal, and must be .020-inch \pm .005-inch. Each bar height is either a tall (full) or short (half) bar, representing a 1 or 0, respectively. Each tall bar must be .125-inch \pm .010-inch; each short bar must be .050-inch \pm .010-inch. Horizontal spacing between bars (pitch) must be 22 bars \pm 2 bars per inch over any 0.50-inch portion of the bar code. Horizontal spacing at 24 and 20 bars per inch is 0.0416-inch and .050-inch, respectively, with a clear vertical space ranging from 0.012-inch to 0.040-inch between bars.

Check Digit

The sixth, tenth or twelfth digit represents the automatic check digit character for the 5, 9 or 11-digit data field, respectively. The check digit is added automatically to verify accurate scanning.

POSTNET Command Format

BARCODE	
POSTNET	[<i>DIR</i> ;] [<i>BFn</i> ;L;] [<i>DARK</i> ;] <i>SR</i> ; <i>SC</i> [(<i>D</i>) <i>data field</i> (<i>D</i>)]
STOP	
BARCODE	The Bar Code command; enter BARCODE .
POSTNET	Designates bar code type POSTNET; enter POSTNET .
<i>DIR</i>	Optional parameter that allows for rotating a barcode. Enter CW for clockwise rotation. Enter CCW or VSCAN for counter-clockwise rotation. Enter INV for inverted rotation. If <i>DIR</i> is not entered, the barcode is horizontally oriented.
<i>BFn</i> ;L	Optional parameters for assigning a dynamic bar code data field location on a form and for designating the length of the data field. With these parameters, the actual data for the bar code data field is provided dynamically during the Execute Form mode; the data is not specified during the Create Form mode. To use this field, perform the following steps: <ol style="list-style-type: none"> Enter BF. Replace <i>n</i> with a number ranging from 1 through 512 to identify the bar code field. The <i>SR</i> and <i>SC</i> parameters specify the exact location of the bar code field identified by <i>n</i>. Replace <i>L</i> with a number equaling the total number of characters in the field. The data field must be numeric and contain exactly 5, 9 or 11 digits. The information for the data field is entered dynamically during the Execute Form mode. (Refer to "Execute Form: Dynamic Bar Code Data" on page 63.) Do not use the <i>data field</i> parameter to enter data when the <i>BFn</i>;L parameters are used. However, refer to the <i>data field</i> description for available characters.
<i>DARK</i>	Optional parameter to produce darker bar codes. Enter DARK . Refer to "Dark Printing" on page 28 for more information.
<i>SR</i>	Defines the starting row for the bar code. Enter a value in the range of the 4-inch vertical address block. Character row or dot row is specified based on the Scale command (page 83), or use the CP.DP format (page 26).

<i>SC</i>	Defines the starting column of the bar code. Enter a value within the 1/2-inch left and right margins of the mail piece. Character column or dot column is specified based on the Scale command (page 83), or use the CP.DP format (page 26).
<i>(D)</i>	The printable character (delimiter) identifying the start and finish of the data field. Enter any printable character other than a slash (/) the SFCC, or a character used within the data. The same character must be used at both ends of the data field but it will not print with the data.
<i>data field</i>	The bar code data. Enter 5 digits (for zip code), 9 digits (for a nine-digit zip code), or 11 digits (for the Advanced Bar Code format). The available characters for the data field are 0 through 9 (30 through 39 hex, respectively).
STOP	Ends the Bar Code command while the IGP continues in the Create Form mode. Enter STOP . If STOP is not entered, an error message will result.

POSTNET Example

Figure 32 illustrates a horizontal POSTNET bar code generated by the following program:

```

~CREATE;POSTNET      (Enter Create Form mode)
BARCODE              (Bar Code command)
POSTNET;DARK;10;40  (Dark POSTNET bar code at SR 10, SC 40)
*601159912*         (ZIP+4 data field 60115-9912)
STOP                 (Ends Bar Code command)
END                  (Terminates Create Form mode)
~EXECUTE;POSTNET;1  (Execute the form, with a form count of 1)

```

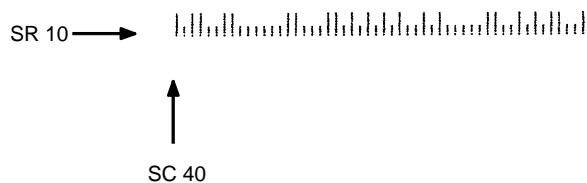

Figure 32. Sample POSTNET Bar Code

PostBar and Royal Mail (KIX)

PostBar and Royal Mail bar codes, like POSTNET, are used for mailing applications. However, these bar codes can encode full addresses on labels. These bar codes are similar to POSTNET in terms of bar space and width, but have four different types of bars (Full Height, Ascender, Descender, and Tracker), whereas POSTNET only has two bar types (Tall and Short).

The Royal Mail symbology converts alphanumeric characters into patterns of four bars, using combinations of Full Height, Ascender, Descender, and Trackers. It also adds start and stop bar codes as well as a check digit, except with the KIX format (see below).

PostBar allows you complete flexibility to specify the individual bar types that comprise the signal. For PostBar, you are responsible for encoding the address, adding the start and stop codes, and supplying the appropriate check digit.

Quiet Zone

The bar code structure requires a completely blank quiet zone which is a 2mm border on each side of the bar code.

Start/Stop Code

The start and stop bars identify the orientation of the bar code.

Data Field

For PostBar, a variable length data field of digits "0" through "3" are allowed to represent the bars: Full Height (0), Ascender (1), Descender (2), and Tracker (3). For Royal Mail, the data is restricted to alphanumeric characters "A" through "Z" and "0" through "9". If using the KIX format for Royal Mail, lowercase characters "a" through "z" are also valid.

Each bar *width* is equal, and must be .020-inch \pm .005-inch. Horizontal spacing between bars (pitch) must be 22 bars \pm 2 bars per inch over any 0.50-inch portion of the bar code. The height of the bars (Full Height) has a maximum of 0.230 inches and a minimum of 0.165 inches.

Check Digit

For PostBar, you are responsible for encoding and check digit. For Royal Mail, a modulo-6 check digit is inserted at the end of the data field.

KIX Format

The KIX format for Royal Mail does not include the start/stop code or the check digit.

PostBar and Royal Mail Command Format

BARCODE	
POSTBAR or ROYALBAR;	[KIX;][MAG;][BFn;L;][DARK;] SR; SC
	[(D)data field(D)]
STOP	
BARCODE	The Bar Code command; enter BARCODE .
POSTBAR or ROYALBAR	Designates bar code type PostBar or Royal Mail; enter POSTBAR or ROYALBAR .
KIX	Optional parameter to specify the KIX format for Royal Mail bar codes only; enter KIX .
MAG	Optional parameter to magnify (horizontally expand) the bar code symbol. The magnification default value is X1 . As required for scanning, enter a magnification value from Table 8 to increase the magnification. Increasing the magnification adjusts printed character density. X1A uses shorter bars to reach the minimum height specification that allows it to fit on a 6 LPI line.
BFn;L	Optional parameters for assigning a dynamic bar code data field location on a form and for designating the length of the data field. With these parameters, the actual data for the bar code data field is provided dynamically during the Execute Form mode; the data is not specified during the Create Form mode. To use this field, perform the following steps: <ol style="list-style-type: none"> Enter BF. Replace <i>n</i> with a number ranging from 1 through 512 to identify the bar code field. The <i>SR</i> and <i>SC</i> parameters specify the exact location of the bar code field identified by <i>n</i>. Replace <i>L</i> with a number equaling the total number of characters in the field. The data field must be numeric and contain exactly 5, 9 or 11 digits. The information for the data field is entered dynamically during the Execute Form mode. (Refer to "Execute Form: Dynamic Bar Code Data" on page 63.) Do not use the <i>data field</i> parameter to enter data when the <i>BFn;L</i> parameters are used. However, refer to the <i>data field</i> description for available characters.
DARK	Optional parameter to produce darker looking bar codes. Enter DARK . Refer to "Dark Printing" on page 28 for more information.

<i>SR</i>	Defines the starting row for the bar code. Character row or dot row is specified based on the Scale command (page 83), or use the CP.DP format (page 26).
<i>SC</i>	Defines the starting column of the bar code. Character column or dot column is specified based on the Scale command (page 83), or use the CP.DP format (page 26).
<i>(D)</i>	The printable character (delimiter) identifying the start and finish of the data field. Enter any printable character other than a slash (/) the SFCC, or a character used within the data. The same character must be used at both ends of the data field but it will not print with the data.
<i>data field</i>	The bar code data. For PostBar, enter values 0 through 3 to represent the four different types of bars. For Royal Mail, enter alphanumeric data (A through Z and 0 through 9). If using the KIX format for Royal Mail, lowercase characters a through z are also valid.
STOP	Ends the Bar Code command while the IGP continues in the Create Form Mode. Enter STOP . If STOP is not entered, an error message will result.

PostBar and Royal Mail Examples

Figure 33 illustrates a horizontal Royal Mail bar code generated by the following program:

```

~CREATE;ROYALBAR      (Enter Create Form Mode)
BARCODE              (Bar Code command)
ROYALBAR;X1A;10;40   (Royal Mail bar code at SR 10,
                    SC 40 with Mag 1A)
*SN34RD1A*          (Data Field)
STOP                (Ends Bar Code command)
END                 (Terminates Create Form Mode)
~EXECUTE;ROYALBAR;1 (Execute the form, with a form count of 1)

```

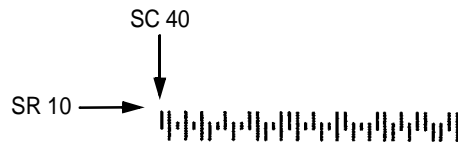

Figure 33. Sample Royal Mail bar code (X1A Magnification)

Figure 34 illustrates a horizontal PostBar bar code generated by the following program:

```

~CREATE;POSTBAR      (Enter Create Form Mode)
BARCODE              (Bar Code command)
POSTBAR;10;40       (PostBar bar code at SR 10, SC
                    40 with default Mag 1)
*10303023123102301031230123210212112210*
                    (Data Field)
STOP                (Ends Bar Code command)
END                 (Terminates Create Form Mode)
~EXECUTE;POSTBAR;1  (Execute the form, with a form count of 1)

```

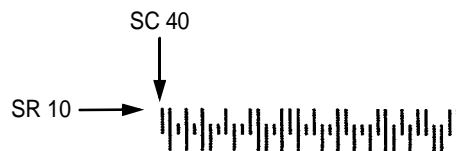

Figure 34. Sample PostBar bar code (X1 Magnification)

Telepen

The Telepen structure is shown in Figure 35 and described on the following pages.

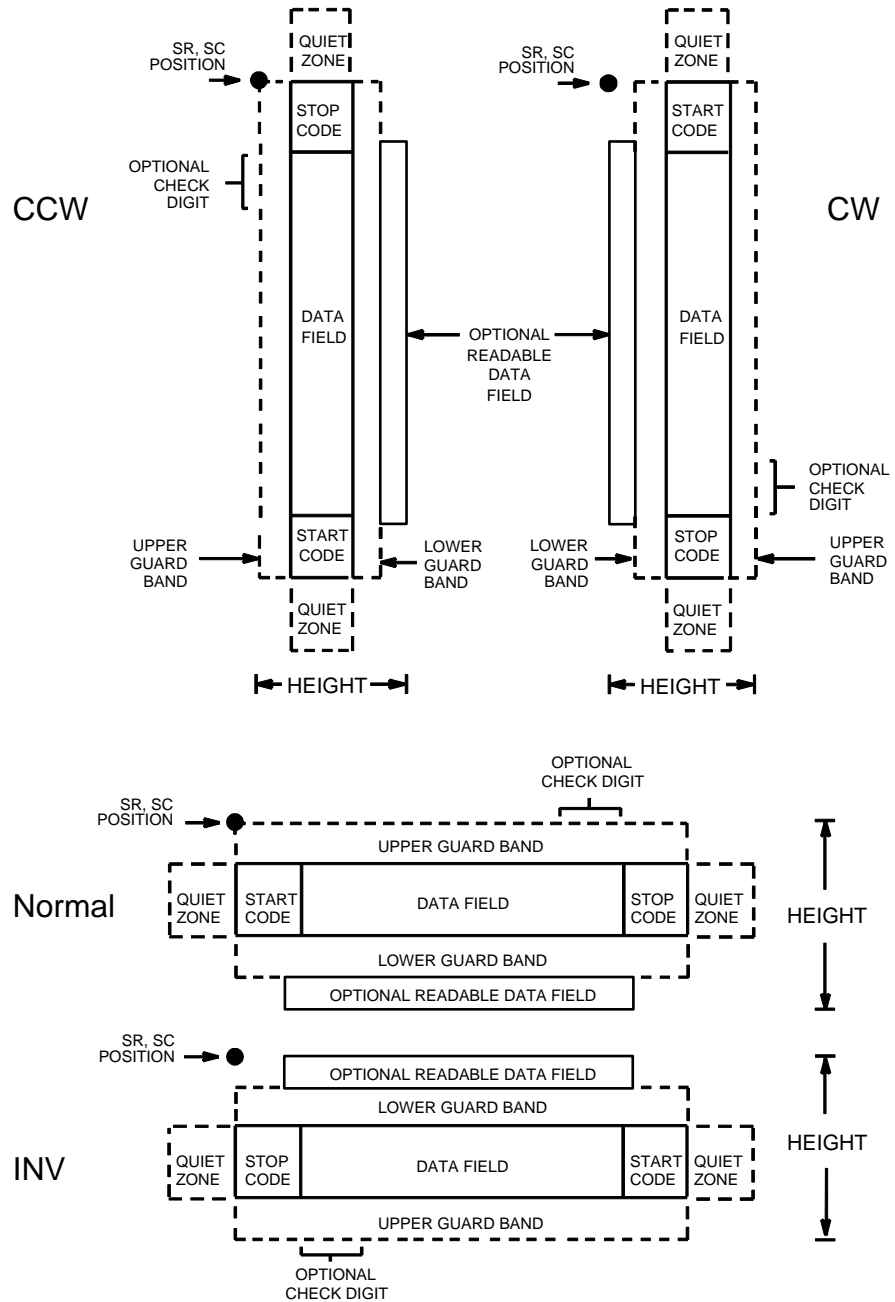

Figure 35. Telepen Structure

Quiet Zone

Both ends of the bar code structure require blank quiet zones. The quiet zones must be at least 0.25 inches wide and completely blank to ensure accurate reading of the start/stop codes and to prevent adjacent bar codes from overlapping. Be sure to provide sufficient space on the form for the quiet zones.

Start/Stop Codes

The start/stop code is a unique character identifying the leading and trailing end of the bar code. The start/stop code is automatically produced with each bar code. The start/stop code structure permits bidirectional bar code scanning.

Data Field

The bar code symbol uses a series of wide and narrow bars and spaces to represent standard alphanumeric characters. Each character is represented by a different series of bars and spaces, both wide and narrow, but is always 16 units in width (for a wide to narrow ratio of 3). Each character starts with a bar and ends with a space.

Readable Data

The optional readable data field provides a readable interpretation of the bar code data. It can be printed above or below the bar code symbol.

Check Digit

A mandatory modulo-127 check digit is inserted into the bar code to verify accurate scanning.

Telepen Command Format

BARCODE

TELEPEN; [*DIR*;] [*MAG*;] [*Hn*[.*m*];] [*BFn*;L;] [*DARK*;] *SR*; *SC*
(*D*) [*data field*] (*D*)

[*PDF* [;*LOC*] [;*FONT*]]

STOP

BARCODE The Bar Code command; enter **BARCODE**.

TELEPEN Designates bar code type Telepen; enter **TELEPEN**.

DIR Optional parameter that allows for rotating a barcode. Enter **CW** for clockwise rotation. Enter **CCW** or **VSCAN** for counter-clockwise rotation. Enter **INV** for inverted rotation. If *DIR* is not entered, the barcode is horizontally oriented.

MAG Optional parameter to magnify (horizontally expand) the bar code symbol. The magnification default value is **X1**. As required for scanning, enter a magnification value from Table 8 to increase the magnification. Increasing the magnification adjusts printed character density. You can also use *XR* or *XRD* as defined on page 89.

Hn[.*m*] Optional parameter to adjust the overall height (vertical expansion) of the bar code symbol (including the upper and lower 0.1-inch guard bands and any human readable data). Height adjustments are made in 0.1-inch increments plus dots; enter **H** and a value from **3** through **99** to select height adjustments from 0.3 through 9.9 inches. The default value is 0.9 inch. [*m*] is an additional number of dots for the bar code height. (Dots are in the current dot scale.)

NOTE: If 0.3 inches is the selected height, the PDF cannot be included.

BFn;L Optional parameters for assigning a dynamic bar code data field location on a form and for designating the length of the data field. With these parameters, the actual data for the bar code data field is dynamically provided during the Execute Form Mode; the data is not specified during the Create Form Mode. To use this field, perform the following steps:

- a. Enter **BF**.
- b. Replace *n* with a number ranging from **1** through **512** to identify the bar code field. The *SR* and *SC* parameters specify the exact location of the bar code field identified by *n*.

- c. Replace *L* with a number equaling the total number of characters in the field. (The actual data provided dynamically during the Execute Form Mode can be less than *L*.)
 - d. The information for the data field is entered dynamically during the Execute Form Mode. (Refer to “Execute Form: Dynamic Bar Code Data” on page 63.) Do not use the *data field* parameter to enter data when the *BFn;L* parameters are used. However, refer to the *data field* description for available characters.
- DARK** Optional parameter to produce darker looking bar codes. Enter **DARK**. Refer to “Dark Printing” on page 28 for more information.
- SR** Defines the starting row for the bar code. Enter a value ranging from row 1 to one less than the length of the form. Character row or dot row is specified based on the Scale command (page 89), or use the CP.DP format (page 26).
- SC** Defines the starting column of the bar code. Enter a value ranging from column 1 to one less than the width of the form. Character column or dot column is specified based on the Scale command (page 89), or use the CP.DP format (page 26).
- (D)** The printable character (delimiter) identifying the start and finish of the data field. Enter any printable character other than a slash (/), the SFCC, or a character used within the data. The same character must be used at both ends of the data field, but it is not printed with the data.
- data field* Contains the bar code characters. A null data field (no characters) is permitted. The data field can contain any of the characters listed in Table 10 except the SFCC. The length of the data field is variable; however, the maximum length is usually limited to 32 characters to minimize potential reading errors.
- PDF** Optional parameter to enable printing of the human readable data field. Enter **PDF** to print the data field. If the parameter is not used, the human readable data will not print. This parameter is not allowed if a null data field is specified.
- LOC** Optional parameter to identify the location of the printable data field. The default value is **B**, locating the human readable data below the bar code. **A** locates the printable data field above bar code. To compensate for printing the 0.1-inch high data, the height of the bar code body is reduced 0.1 inch.

FONT Optional parameter to select the font for the human readable data field. Enter **O** to select OCR-A font; enter **X** to select OCR-B font; enter **N** to select 10 cpi; enter **P** to select 12 cpi; enter **Q** to select 13 cpi; enter **R** to select 15 cpi; enter **T** to select 17 cpi; enter **V** to select 20 cpi.

STOP Ends the Bar Code command while the IGP/PGL continues in the Create Form Mode. Enter **STOP**. If **STOP** is not entered, an error message results.

Table 16. Telepen Character Set

ASCII	Telepen	ASCII	Telepen	ASCII	Telepen	ASCII	Telepen
NUL	%U	SP	Space	@	%V	`	%W
SOH	\$A	!	/A	A	A	a	+A
STX	\$B	"	/B	B	B	b	+B
ETX	\$C	#	/C	C	C	c	+C
EOT	\$D	\$	/D	D	D	d	+D
ENQ	\$E	%	/E	E	E	e	+E
ACK	\$F	&	/F	F	F	f	+F
BEL	\$G	'	/G	G	G	g	+G
BS	\$H	(/H	H	H	h	+H
HT	\$I)	/I	I	I	i	+I
LF	\$J	*	/J	J	J	j	+J
VT	\$K	+	/K	K	K	k	+K
FF	\$L	,	/L	L	L	l	+L
CR	\$M	—	—	M	M	m	+M
SO	\$N	.	.	N	N	n	+N
SI	\$O	/	/O	O	O	o	+O
DLE	\$P	0	0	P	P	p	+P
DC1	\$Q	1	1	Q	Q	q	+Q
DC2	\$R	2	2	R	R	r	+R
DC3	\$S	3	3	S	S	s	+S
DC4	\$T	4	4	T	T	t	+T
NAK	\$U	5	5	U	U	u	+U
SYN	\$V	6	6	V	V	v	+V
ETB	\$W	7	7	W	W	w	+W
CAN	\$X	8	8	X	X	x	+X
EM	\$Y	9	9	Y	Y	y	+Y
SUB	\$Z	:	/Z	Z	Z	z	+Z
ESC	%A	;	%F	[%K	{	%P
FS	%B	<	%G	\	%L		%Q
GS	%C	=	%H]	%M	}	%R
RS	%D	>	%I	^	%N	~	%S
US	%E	?	%J	—	%O	DEL	%T %X %Y %Z

NOTE: Character pairs /M, /N, and /P through /Y are reserved for future control character pairs.

Telepen Example

Figure 36 illustrates a vertical Telepen bar code generated by the following program:

```
~CREATE;TELEPEN      (Enter Create Form Mode)
BARCODE              (Bar Code Command)
TELEPEN;VSCAN;10;5  (Vertical Telepen barcode at SR 10, SC 5)
"AB12&%*"           (Data Field)
PDF;B                (Printable Data Field)
STOP                 (Ends Bar Code Command)
END                  (Terminates Create Form Mode)
~EXECUTE;TELEPEN;1  (Execute the form, form count of 1)
```

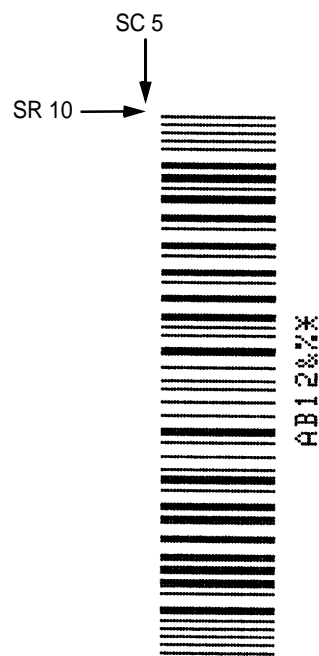

Figure 36. Sample Telepen Bar Code

UCC/EAN-128

The UCC/EAN-128 structure is shown in Figure 37 and described on the following pages.

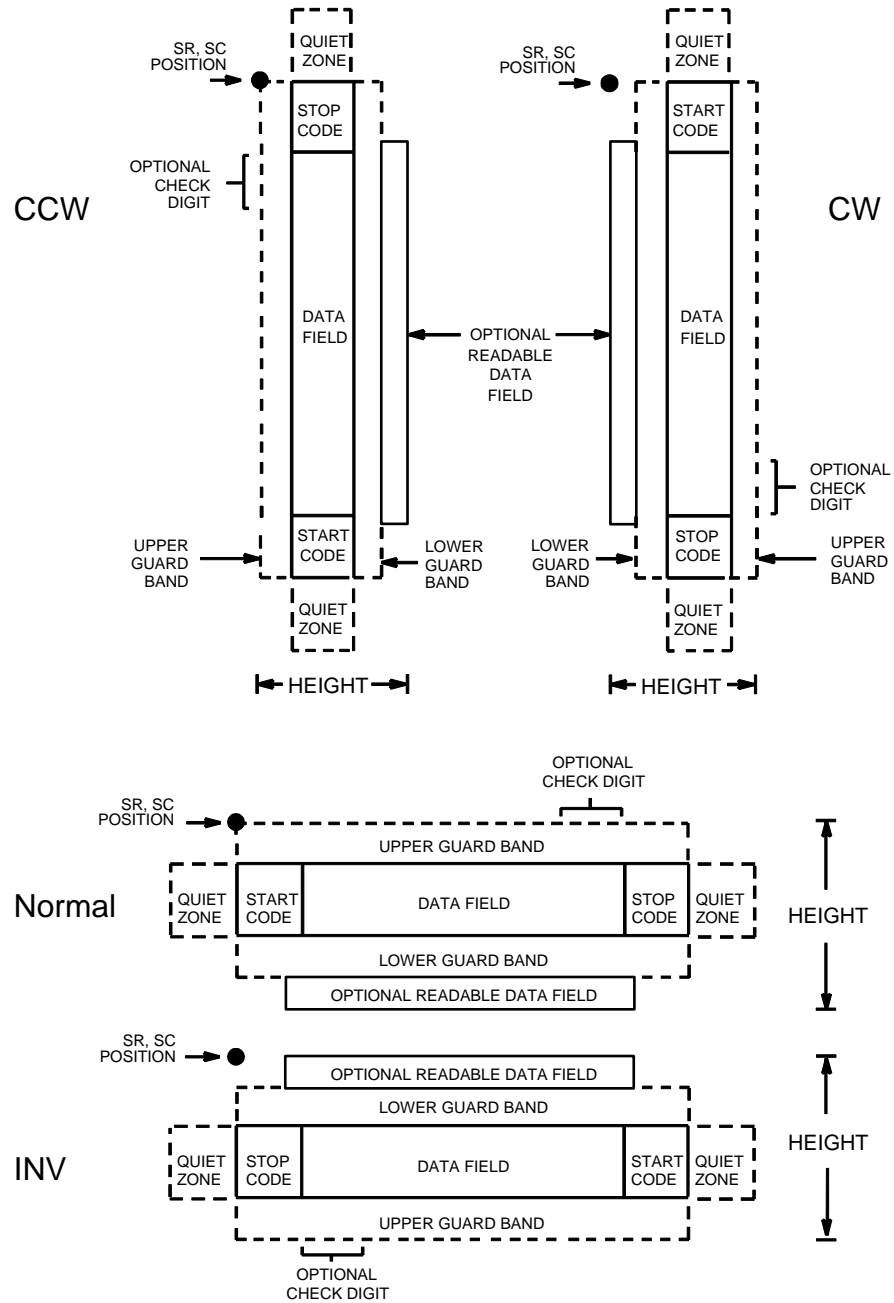

Figure 37. UCC/EAN-128 Structure

UCC/EAN-128 uses the same bar code and character set as Code 128. However, in UCC/EAN-128, the Function 1 character FNC1 immediately follows the start code. The FNC1 character has been reserved exclusively for UCC/EAN-128.

The UCC/EAN-128 data structure requires an Application Identifier (AI) at the beginning of bar code data. Each AI determines the format and length of the data which follows. Refer to Table 17 for more detail.

Table 17. UCC/EAN-128 Application Identifiers

Application Identifier (AI)	Content	Format
00	Serial Shipping Container Code	n2+n18
02	Item Num. of Goods Within Another Unit	n2+n14
10	Batch or Lot Number	n2+an..20
11 (*)	Production Date (YYMMDD)	n2+n6
13 (*)	Packaging Date (YYMMDD)	n2+n6
15 (*)	Sell By Date (Quality) (YYMMDD)	n2+n6
17 (*)	Expiration Date (Safety) (YYMMDD)	n2+n6
20	Product Variant	n2+n2
21	Serial Number	n2+an..20
22	HIBCC = Quantity, Date, Batch and Link	n2+an..29
23 (**)	Lot Number (Transitional Use)	n3+n..19
240	Additional Product ID Assigned By Manufacturer	n3+an..30
250	Secondary Serial Number	n3+an..30
30	Quantity	n2+n..8
310 (***)	Net Weight, Kilograms	n4+n6
311 (***)	Length or 1st Dimension, Meters	n4+n6
312 (***)	Width, Diameter or 2nd Dimension, Meters	n4+n6
313 (***)	Depth, Thickness, Height or 3rd Dimension, Meters	n4+n6
314 (***)	Area, Square Meters	n4+n6
315 (***)	Volume, Liters	n4+n6
316 (***)	Volume, Cubic Meters	n4+n6
320 (***)	Net Weight, Pounds	n4+n6
321 (***)	Length Or 1st Dimension, Inches	n4+n6
322 (***)	Length Or 1st Dimension, Feet	n4+n6
323 (***)	Length Or 1st Dimension, Yards	n4+n6
324 (***)	Width, Diameter, or 2nd Dimension, Inches	n4+n6
325 (***)	Width, Diameter, or 2nd Dimension, Feet	n4+n6
326 (***)	Width, Diameter, or 2nd Dimension, Yards	n4+n6
327 (***)	Depth, Thickness, Height, or 3rd Dimension, Inches	n4+n6
328 (***)	Depth, Thickness, Height, or 3rd Dimension, Feet	n4+n6

Table 17. UCC/EAN-128 Application Identifiers (continued)

Application Identifier (AI)	Content	Format
329 (***)	Depth, Thickness, Height, or 3rd Dimension, Yards	n4+n6
330 (***)	Gross Weight-Kilograms	n4+n6
331 (***)	Length or 1st Dimension, Logistics	n4+n6
332(***)	Width, Diameter, or 2nd Dimension, Meters, Logistics	n4+n6
333 (***)	Depth, Thickness, Height or 3rd Dimension, Meters, Logistics	n4+n6
334 (***)	Area, Square Meters, Logistics	n4+n6
335 (***)	Gross Volume, Liters	n4+n6
336 (***)	Gross Volume, Cubic Meters	n4+n6
337 (***)	Kilograms Per Square Meter	n4+n6
340 (***)	Gross Weight, Pounds	n4+n6
341 (***)	Length Or 1st Dimension, Inches, Logistics	n4+n6
342 (***)	Length Or 1st Dimension, Feet, Logistics	n4+n6
343 (***)	Length Or 1st Dimension, Yards, Logistics	n4+n6
344 (***)	Width, Diameter, or 2nd Dimension, Inches, Logistics	n4+n6
345 (***)	Width, Diameter, or 2nd Dimension, Feet, Logistics	n4+n6
346 (***)	Width, Diameter, or 2nd Dimension, Yards, Logistics	n4+n6
347 (***)	Depth, Thickness, Height or 3rd Dimension, Inches, Logistics	n4+n6
348 (***)	Depth, Thickness, Height or 3rd Dimension, Feet, Logistics	n4+n6
349 (***)	Depth, Thickness, Height or 3rd Dimension, Yards, Logistics	n4+n6
350 (***)	Area, Square Inches	n4+n6
351 (***)	Area, Square Feet	n4+n6
352 (***)	Area, Square Yards	n4+n6
353 (***)	Area, Square Inches, Logistics	n4+n6
354 (***)	Area, Square Feet, Logistics	n4+n6
355 (***)	Area, Square Yards, Logistics	n4+n6
356 (***)	Net Weight, Troy Ounce	n4+n6
357 (***)	Net Volume, Ounces	n4+n6
360 (***)	Volume, Quarts	n4+n6
361 (***)	Volume, Gallons	n4+n6
362 (***)	Gross Volume, Quarts	n4+n6
363 (***)	Gross Volume, Gallons	n4+n6
364 (***)	Volume, Cubic Inches	n4+n6
365 (***)	Volume, Cubic Feet	n4+n6
366 (***)	Volume, Cubic Yards	n4+n6
367 (***)	Gross Volume, Cubic Inches	n4+n6
368 (***)	Gross Volume, Cubic Inches	n4+n6

Table 17. UCC/EAN-128 Application Identifiers (continued)

Application Identifier (AI)	Content	Format
369 (***)	Gross Volume, Cubic Inches	n4+n6
37	Quantity of Units Contained (For Use With AI 02 Only)	n2+n..8
400	Customer's Purchase Order Number	n3+an..30
401	Consignment Number	n3+an..30
410	Ship To (Deliver To) Location Code Using EAN-13	n3+n13
411	Bill To (Invoice To) Location Code Using EAN-13	n3+n13
412	Purchase From (Location Code of Party From Whom Goods Are Purchased)	n3+n13
413	Ship For UCC/EAN Location Code	n3+n13
414	EAN Location Code For Physical Identification	n3+n13
420	Ship To (Deliver To) Postal Code Within a Single Postal Authority	n3+an..20
421	Ship To (Deliver To) Postal Code With 3-Digit ISO Country Code Prefix	n3+n3+an..9
8001	Roll Products-Width, Length, Core Diameter, Direction and Splices	n4+n14
8003	UPC/EAN Number and Serial Number Or Returnable Asset	n4+n14+an..16
8004	UCC/EAN Serial Identification	n4+an..30
8005	Identifies the Price Per Unit of Measure	n4+n6
8006	Component of an Article	n4+n14+n2+n2
8018	Service Relation Number	n4+n18
8100	Coupon Extended Code-Number System Character and Offer	n4+n1+n5
8101	Coupon Extended Code-Number System Character, Offer and End of Offer	n4+n1+n5+n4
8102	Coupon Extended Code-Number System Character Preceded by Zero	n4+n1+n1
90	Mutually Agreed, Between Trading Partners	n2+an..30
91	Intra-Company (Internal)	n2+an..30
92	Intra-Company (Internal)	n2+an..30
93	Intra-Company (Internal)	n2+an..30
94	Intra-Company (Internal)	n2+an..30
95	Internal-Carriers	n2+an..30
96	Internal-Carriers	n2+an..30
97	Intra-Company (Internal)	n2+an..30
98	Intra-Company (Internal)	n2+an..30
99	Internal	n2+an..30

(*)To indicate only year and month, DD must be filled with "00"

(**) Plus one digit for length indication

(***) Plus one digit for decimal point indication

Data Value Representation:

a - alphabetic characters

an - alpha-numeric characters

an..3 - up to 3 alpha-numeric characters

n - numeric characters

n3 - 3 numeric characters, fixed length

n..3 - up to 3 numeric characters

Quiet Zone

Both ends of the bar code structure require blank quiet zones. The quiet zones must be at least 0.25 inches wide and completely blank to ensure accurate reading of the start/stop codes and to prevent adjacent bar codes from overlapping. You must provide sufficient space on the form for the quiet zones.

Start/Stop Codes

The start and stop codes identify the leading and trailing ends of the bar code. UCC/EAN-128 uses unique start codes for character subsets B and C, and a stop code common to both. An automatic mode switching feature is used to generate the correct start code based on the first four data field characters.

Data Field

UCC/EAN-128 bar codes require a special character called "Function 1" (FNC1) to immediately follow the start code. IGP automatically supplies this character, so it must not be included in the data field by the user.

A character is made up of three bars and three spaces, each varying in width from 1 to 4 modules, for a total of eleven modules. The number of modules making up the bars is even. The stop code has four bars and is 13 modules wide.

The character set for UCC/EAN-128 is the same as the character set for Code 128. Refer to the Code 128 Character Set, Table 13 and Table 14. Every character is interpreted according to the currently active character subset. UCC/EAN-128 uses subset B and subset C only. Subset B, shown in Table 13, includes all standard alphanumeric keyboard characters, lowercase alphabetical characters, and special characters. Subset C interprets the characters as pairs of numbers 00 through 99, along with some special characters, as shown in Table 14. The start code or subset switch code determines whether a particular bar code character is decoded as one character or as a pair of numbers.

Readable Data

The optional printed data field (PDF) provides a human-readable interpretation of the bar code data. When the printed data field is enabled by use of the "PDF" parameter, the overall height of the bars is reduced to make room for a guard band and the human-readable characters. The printed data field will be formatted with spaces or parentheses denoting particular data fields such as the application identifier. Special characters such as start, stop, subset switch, modulo-103 check digit, and FNC1 do not appear in the human-readable data.

The readable data is oriented along the bar code from start code to stop code. It may be positioned above or below a bar code, and the bar code may be horizontal, vertical, or inverted.

Modulo-103 Check Digit

A modulo-103 check digit is automatically calculated and inserted in the bar code symbol immediately in front of the stop code, in the same manner as the C128 bar code. The check digit verifies accurate scanning. The start code is included in the check digit algorithm. The modulo-103 check digit is not displayed in the readable data field.

Modulo-10 Data Field Check Digit for SSCC-18 and SCC-14

AI 00 (called the Serial Shipping Container Code, or SSCC-18) takes eighteen additional numerical data bytes. The last data byte is a modulo-10 check digit on the preceding seventeen data bytes. Counting the two zeros of the application identifier, the modulo-10 check digit is the twentieth byte in the data field.

AI 01 (called the Shipping Container Code, or SCC-14) takes fourteen additional numerical data bytes. The last data byte is a modulo-10 check digit on the preceding thirteen data bytes. Counting the zero and the one of the application identifier, the modulo-10 check digit is the sixteenth byte in the data field.

The modulo-10 data field check digit for both SSCC-18 and SCC-14 is printed in the bar code as the second half of the last number pair using subset C. It is displayed in the human-readable data field as the twentieth byte for SSCC-18 or the sixteenth byte for SCC-14.

IGP/PGL automatically calculates the modulo-10 check digit for SSCC-18 if only 17 data digits are provided following the application identifier of 00.

Code UCC-128 Command Format

BARCODE

UCC-128; [*DIR*]; [*MAG*]; [*Hn*].*m*]; [*BFn*;L]; [*DARK*]; *SR*; *SC*

[*(D)*data field(*D*)]

[*PDF* [;L*OC*] [;F*ONT*]]

STOP

BARCODE The Bar Code command; enter **BARCODE**.

UCC-128 Designates bar code type Code UCC/EAN-128; enter **UCC-128**.

DIR Optional parameter that allows for rotating a barcode. Enter **CW** for clockwise rotation. Enter **CCW** or **VSCAN** for counter-clockwise rotation. Enter **INV** for inverted rotation. If *DIR* is not entered, the barcode is horizontally oriented.

MAG Optional parameter to magnify the bar code symbol by increasing the width of the bars and spaces. The magnification default value is **X1**. Increasing the magnification adjusts printed character density as shown in Table 8. You can also use **XR** as defined on page 89. You must specify eight digits for variable ratio. They stand for the widths of alternating bars and spaces from the narrowest to the widest. Note that a valid UCC/EAN-128 bar code can be no larger than 165 mm (6.5 inches) wide.

Hn].*m*] Optional parameter to adjust the overall height of the bar code symbol (including the upper and lower 0.1 inch guard bands and any human-readable data). Height adjustments are made in 0.1 inch increments; enter **H** and a value from **3** through **99** to select height adjustments from 0.3 through 9.9 inches. The default value is 0.9 inch. The [*.m*] provides an additional number of dots for the bar code height. (Dots are in the current scale).

Note



If 0.3 inches is the selected height, the PDF cannot be included.

BFn;L Optional parameters for assigning a dynamic bar code data field location on a form and for designating the length of the data field. With these parameters, the actual data for the bar code data field is dynamically provided during the Execute Form mode; the data is not specified during the Create Form mode. To use this field, perform the following steps:

- a. Enter **BF**.

- b. Replace n with a number ranging from 1 through 512 to identify the bar code field. The SR and SC parameters specify the exact location of the bar code field identified by n .
- c. Replace L with the maximum number of characters in the field. The actual data provided dynamically during the Execute Form mode can be less than L . It is permitted to supply no data at all.
- d. The information for the data field is entered dynamically during the Execute Form mode. (Refer to “Execute Form: Dynamic Bar Code Data” on page 63.) Do not use the *data field* parameter to enter data when the $BFn;L$ parameters are used. However, refer to the *data field* description for available characters to use during Execute Form mode.

DARK	Optional parameter to produce darker bar codes. Enter DARK. Refer to “Dark Printing” on page 28 for more information.
SR	Defines the starting row for the bar code. Enter a value ranging from row 1 to one less than the length of the form. Character row or dot row is specified based on the Scale command, or use the CP.DP format.
SC	Defines the starting column of the bar code. Enter a value ranging from column 1 to one less than the width of the form. Character column or dot column is specified based on the Scale command, or use the CP.DP format.
(D)	The printable character (delimiter) identifying the start and finish of the data field. Enter any printable character other than a slash (/), the SFCC, or a character used within the data. The same character must be used on both ends of the data field. It will not print with the data.
<i>data field</i>	<p>The bar code data. The data field for UCC/EAN-128 consists of an “application identifier” (AI) of two to four numbers, followed by data of appropriate length (variable or fixed) and type (numeric or alphanumeric). See Table 17 for a list of application identifiers and their associated data fields.</p> <p>The FNC1 character is required as the first character after the start code for UCC/EAN-128 bar codes, and IGP will always generate it automatically. It will appear in the bar code but not in the human readable field. Do not supply FNC1 in the data field.</p>

The start code and subset switching is done automatically by IGP based on the data field contents so that the bar code length is minimized. Subset C encodes each pair of numbers as a single bar code character, providing a higher character density. If the first four data digits are numbers, the bar code starts in subset C; otherwise it starts in subset B. The subset will switch from B to C at any point in the data field if the next four characters are numbers, and will switch from C to B if the next two characters are not numbers or only one character remains.

The data field can contain any of the characters listed in Table 13 except the system SFCC and the character used as a delimiter.

<i>PDF</i>	Optional parameter to enable printing of the human readable data field. Enter PDF to print the data field. If this parameter is not used, the human readable data will not print. This parameter is not allowed if a null data field was specified.
<i>LOC</i>	Optional parameter to identify the location of the printable data field. The default value is B , locating the human readable data below the bar code. A locates the printable data field above the bar code. The height of the bar code body is reduced to compensate for the human readable field and the guard bands.
<i>FONT</i>	Optional parameter to identify the font of the printable data field. Enter O to select OCR-A font; enter X to select OCR-B font; enter N to select 10 cpi; enter P to select 12 cpi; enter Q to select 13 cpi; enter R to select 15 cpi; enter T to select 17 cpi; enter V to select 20 cpi.
<i>STOP</i>	Ends the bar code command while the IGP continues in the Create Form mode. Enter STOP . If STOP is not encountered, an error message results.

Code UCC/EAN-128 Examples

The following example generates the SSCC-18 variant of an UCC/EAN-128 bar code in horizontal orientation at the default ratio, and vertically at a user defined ratio of double normal size.

```

~CREATE;UCCTEST
/ Horizontal bar code is dark, nominal width, start row 35,
start column 15.
/ Human-readable field is below the bar code in OCR-B font.
BARCODE
UCC-128;DARK;35;15
"0034567890123456789"
PDF;X
STOP
/ Vertical bar code is dark, double width, start row 35, start
column 50.
/ Human-readable data field is above the bar code in normal 10
dpi font.
BARCODE
UCC-128;VSCAN;XR2:2:4:4:6:6:8:8;H12;DARK;35;50
"0034567890123456789"
PDF;A
STOP
END
~EXECUTE;UCCTEST

~NORMAL

```



The program below illustrates incremental UCC/EAN-128 bar codes. Incremental UCC/EAN-128 bar code syntax requires that the STARTMASK field be one character wider than the data field. Put an extra "X" on the left side of the STARTMASK, since the data is right-justified in the STARTMASK field.

```

~CREATE;UCCINC;140
/ Purchase Order number (incremental)
/ Note that there are 14 characters in the data,
/ and the STARTMASK is 15 characters wide.
/ The mask is set to increment only the last five numbers of
the data.
BARCODE
UCC-128;I;DARK;3;20
+XXXXXXXXXX00001;"400PO11960001"
PDF;B
STOP
ALPHA
DARK;1;20;0;0;"PURCHASE ORDER NUMBER"
STOP
END
~EXECUTE;UCCINC;3

~NORMAL

```

PURCHASE ORDER NUMBER



{400}PO11960001

PURCHASE ORDER NUMBER



{400}PO11960002

PURCHASE ORDER NUMBER



{400}PO11960003

The following example shows the use of dynamic data. The ship-to-postal code, AI 420, is used to encode 5 digit ZIP Codes.

```

~CREATE;UCCDYN;140
BARCODE
UCC-128;BF1;8;3;20
PDF;X
STOP
ALPHA
DARK;1;20;0;0;"SHIP TO POSTAL"
STOP
END
~EXECUTE;UCCDYN
~BF1;"42092614"

~NORMAL
~EXECUTE;UCCDYN
~BF1;"42090210"

~NORMAL
~EXECUTE;UCCDYN
~BF1;"42090028"

~NORMAL
    
```

SHIP TO POSTAL

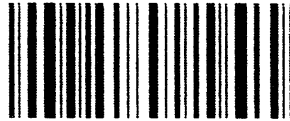

(420)92614

SHIP TO POSTAL



(420)90210

SHIP TO POSTAL



(420)90028

UPC-A

The UPC-A bar code structure is shown in Figure 38 and described on the following pages.

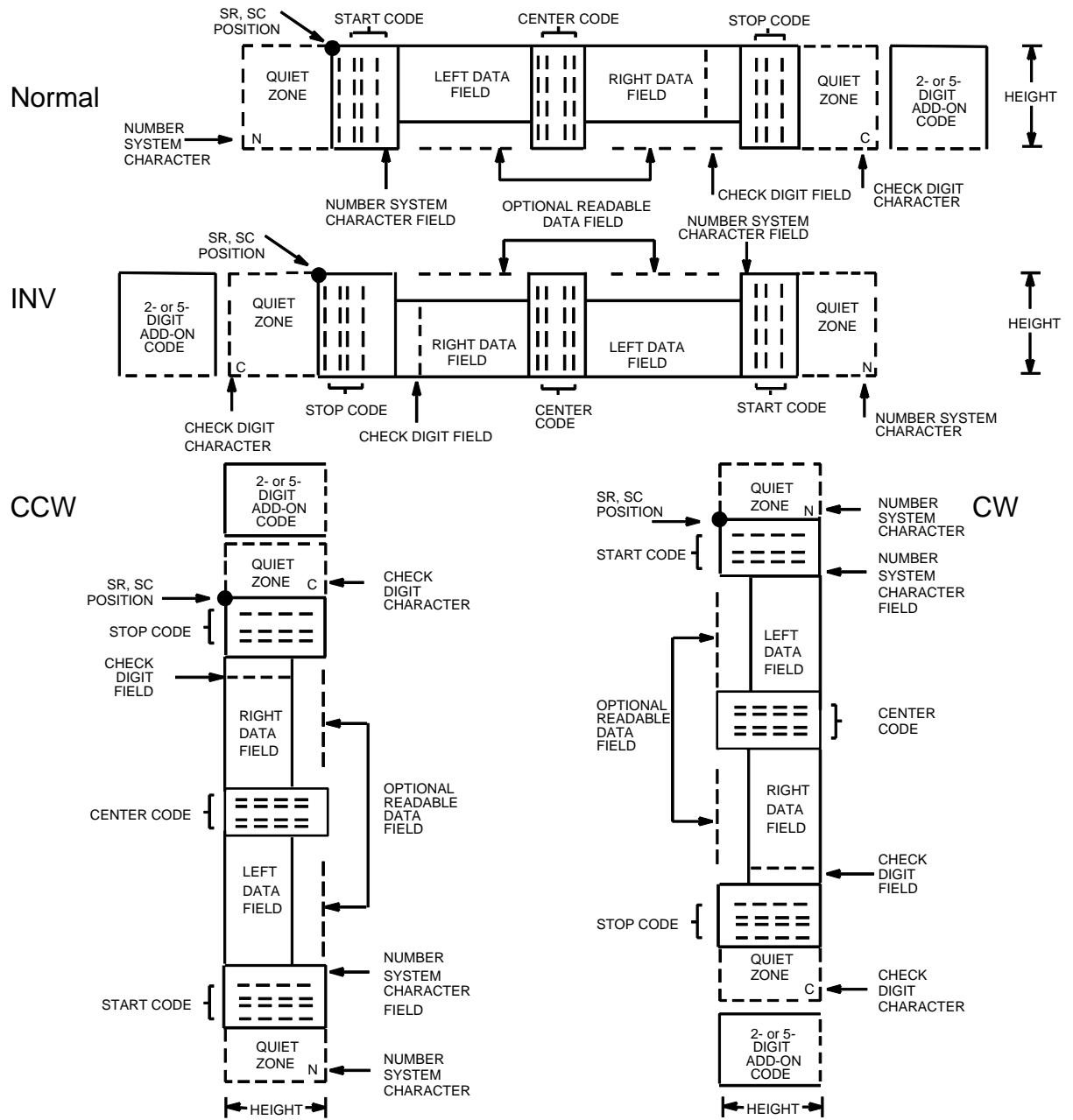

Figure 38. UPC-A Structure

Quiet Zone

Quiet zones extend on both ends of the bar code to permit the scan to begin and end in a blank area. The IGP automatically produces an 11-module wide left quiet zone; you are responsible for providing sufficient space (minimum of seven modules) on the form for the right quiet zone. The number system character is also printed automatically in the left quiet zone.

Start/Center/Stop Codes

The start/center/stop codes are special character codes marking those portions of the bar code. These codes are automatically provided.

Number System Character

The number system character field allows you to provide a code to a class or type of item. The first character in the data field is used as the number system character.

Data Field

The bar code symbol uses a series of varying width bars and spaces to represent a limited character set (numbers 0-9 and Special Characters Start, Center, and Stop). The bars and spaces vary in width from one through four modules. Each character consists of two bars and two spaces that total seven modules. The symbol coding of the left data field is different from the right data field to permit read direction sensing.

The optional 2- or 5-digit add-on data field is placed at the end of the bar code and typically identifies a periodical issue number or price, respectively.

Readable Data

The human readable data field provides a readable interpretation of the bar code data. It can either be suppressed or printed above or below the bar code symbol.

Check Digit

The modulo-10 check digit is automatically calculated and inserted in the bar code symbol. The check digit verifies accurate scanning. The number system character is included in the check digit algorithm.

UPC-A Command Format

BARCODE

UPC-A [+n];[DIR]; [SCB]; [MAG]; [Hn[.m)]; [BFn]; [DARK;]SR;SC
[(D)data field(D)]

[PDF [;LOC] [;FONT]

STOP

BARCODE The Bar Code command; enter **BARCODE**.

UPC-A Designates bar code type UPC-A; enter **UPC-A**.

+n Optional parameter to provide a 2- or 5-digit add-on code at the end of the bar code data field. Enter a plus sign (+) and a value of **2** or **5**. The first bar of the add-on code is separated by nine modules from the last bar of the UPC symbol and a left guard pattern.

DIR Optional parameter that allows for rotating a barcode. Enter **CW** for clockwise rotation. Enter **CCW** or **VSCAN** for counter-clockwise rotation. Enter **INV** for inverted rotation. If **DIR** is not entered, the barcode is horizontally oriented.

SCB This option shortens the length of the center guard bars, which are normally full length.

MAG Optional parameter to magnify (horizontally expand) the bar code symbol. The magnification default value is **X1**. Enter a magnification value from Table 8 to increase the magnification. Increasing the magnification adjusts printed character density. You can also use **XR** or **XRD** as defined on page 89. (You must specify 8 digits for **MAG** for variable ratio.)

Hn[.m] Optional parameter to adjust the overall height (vertical expansion) of the bar code symbol (including the upper and lower 0.1-inch guard bands and any human readable data). Height adjustments are made in 0.1-inch increments; enter **H** and a value from **4** through **99** to select height adjustments from 0.4 through 9.9 inches. The default value is 1.3 inches. The [.m] provides an additional number of dots for the bar code height. (Dots are in the current dot scale.)

BFn Optional parameter for assigning a dynamic bar code data field location on a form. With this parameter, the actual data for the bar code data field is provided dynamically during the Execute Form mode; the data is not specified during the Create Form mode. To use this field, perform the following steps:

- a. Enter **BF**.

- b. Replace n with a number ranging from 1 through 512 to identify the bar code field. The SR and SC parameters specify the exact location of the bar code field identified by n .
- c. The length of the data field need not be specified, since it is fixed at 11 digits, plus any add-on data.
- d. The information for the data field is entered dynamically during the Execute Form mode. (Refer to “Execute Form: Dynamic Bar Code Data” on page 63.) Do not use the *data field* parameter to enter data when the BFn parameters are used. However, refer to the *data field* description for available characters.

DARK	Optional parameter to produce darker bar codes. Enter DARK . Refer to “Dark Printing” on page 28 for more information.
SR	Defines the starting row for the bar code. Enter a value ranging from row 1 to one less than the length of the form. Character row or dot row is specified based on the Scale command (page 83), or use the CP.DP format (page 26).
SC	Defines the starting column of the bar code. Enter a value ranging from column 1 to one less than the width of the form. Character column or dot column is specified based on the Scale command (page 83), or use the CP.DP format (page 26).
(D)	The printable character (delimiter) identifying the start and finish of the data field. Enter any printable character other than a slash (/), the SFCC, or a character used within the data. (It will not print with the data.) Use the same character at both ends of the data field.
<i>data field</i>	Enter the characters for the bar code data, restricted to exactly 11 digits. If the 2- or 5-digit add-on data option is used, include this data at the end of the data field. The first digit is interpreted as the number system character. The remaining 10 digits are the data field characters. The characters available for the data field and number system are 0 through 9 (30 through 39 hex, respectively).

PDF	Optional parameter which affects printing of the human readable data field. The data field will print automatically unless the PDF-suppress command is specified in the <i>FONT</i> parameter. UPC-A human readable fields can be printed above or below the bar code symbol. If the PDF command is not entered in the UPC-A command format, the data field automatically prints in OCR-B.
LOC	Optional parameter to identify the location of the printable data field. The default value is B , locating the human readable data below the bar code. A locates the printable data field above the bar code. To compensate for printing the 0.1-inch high data, the height of the bar code body is reduced 0.1-inch.
FONT	Optional parameter to select the font for the human readable data field. The default font type for UPC-A bar codes is OCR-B; if no PDF command is entered in the command format, the data field is printed automatically in OCR-B. Entering X will also designate the OCR-B type font. Enter N to select the normal ASCII 10 cpi font; enter O to select the OCR-A 10 cpi font. Enter P to select 12 cpi. Enter Q to select 13 cpi. Enter R to select 15 cpi. Enter T to select 17 cpi. Enter V to select 20 cpi. Enter S to suppress printing the data field and the trailing lower portions of the UPC bar code.
STOP	Ends the Bar Code command while the IGP continues in the Create Form mode. Enter STOP . If STOP is not entered, an error message results.

UPC-A Example

Figure 39 illustrates a horizontal and vertical UPC-A bar code generated by the following program:

```

~CREATE;UPCA      (Enter Create Form mode)
BARCODE          (Bar Code command)
UPC-A+5;H9;DARK;39;15
                  (Dark Code UPC-A, 5-digit
                  add-on, H 0.9, SR 39, SC 15)
*1234567887655555* (Data Field plus 5-digit add-on data field)
PDF              (Printable Data Field)
STOP             (Ends Bar Code command)
BARCODE          (New Bar Code command)
UPC-A+5;VSCAN;H1.2;DARK;39;50
                  (Vertical Dark UPC-A, 5-digit
                  add-on,H 1.2, SR 39, SC 50)
*1234567887655555* (Data Field plus 5-digit add-on data field)
PDF              (Printable Data Field)
STOP             (Ends Bar Code command)
END              (Terminates Create Form mode)
~EXECUTE;UPCA;1  (Executes the form, form count of 1)
    
```

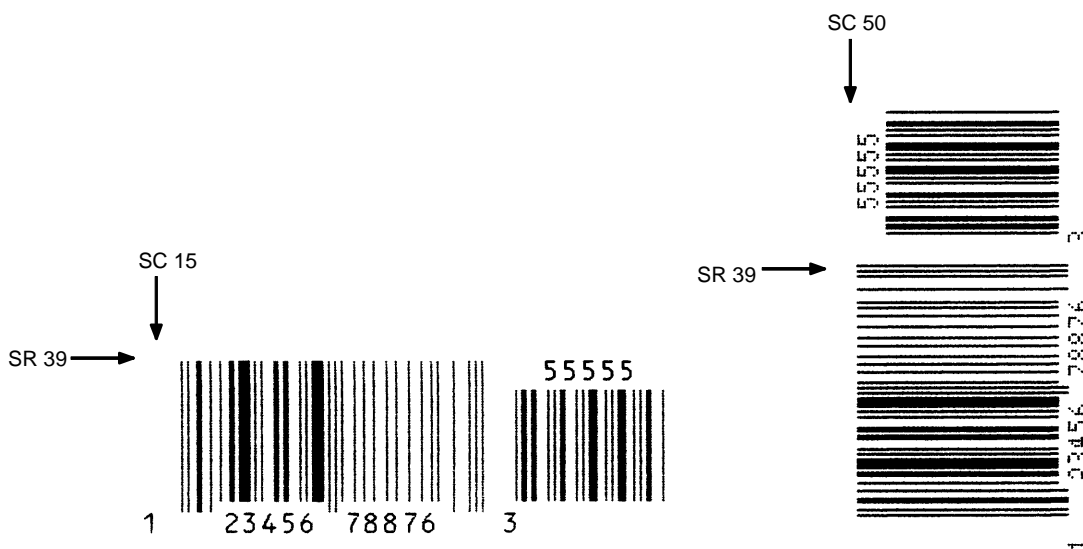

Figure 39. Sample UPC-A Bar Codes with Add-On Data

UPC-E and UPC-E0

The UPC-E and UPC-E0 bar code structure is shown in Figure 40 and described on the following pages.

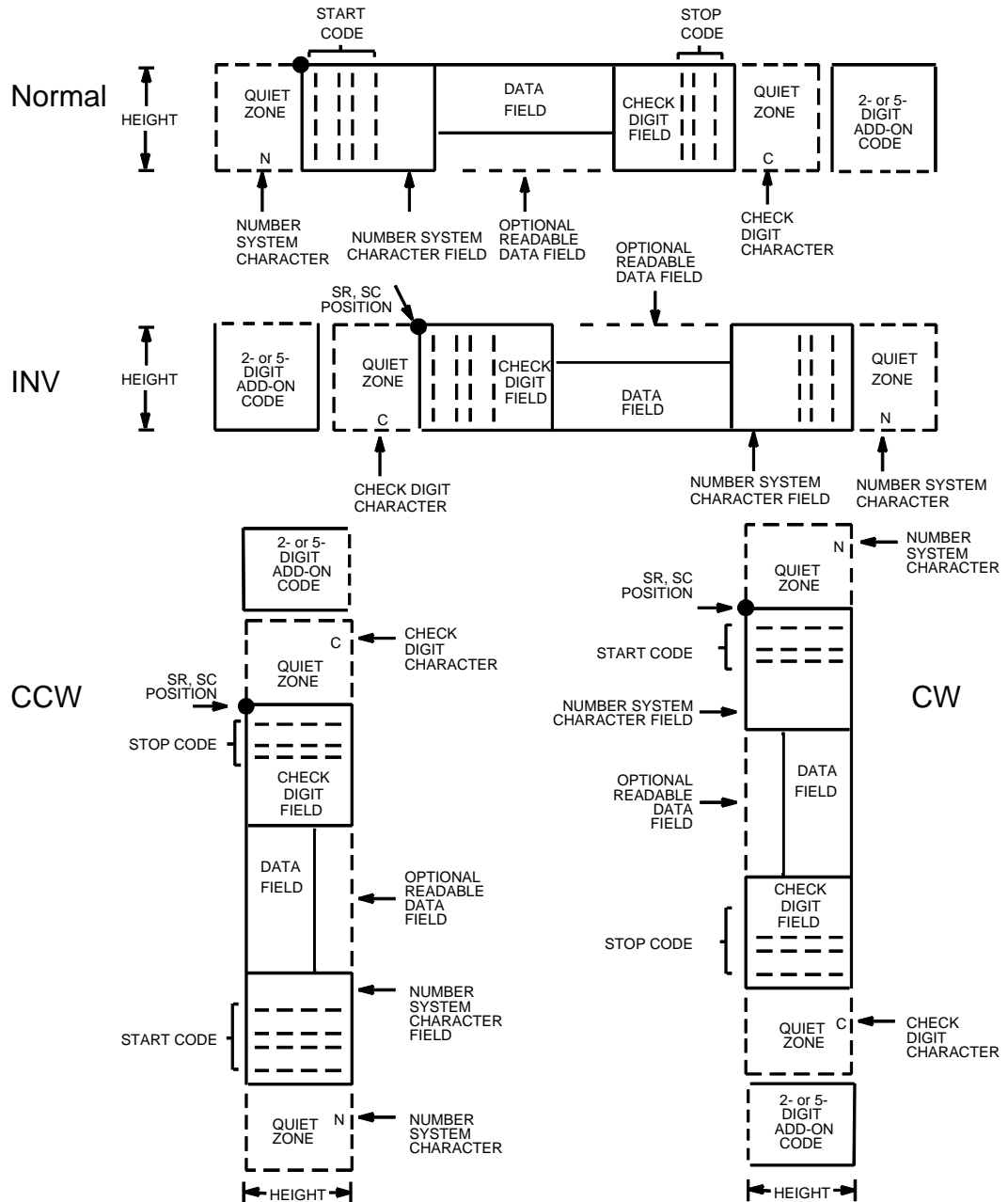

Figure 40. UPC-E and UPC-E0 Structure

Quiet Zone

Quiet zones extend on both ends of the bar code to permit the scan to begin and end in a blank area. The IGP automatically produces an 11-module wide left quiet zone. You must provide sufficient space (minimum of seven modules) on the form for the right quiet zone. The number system character is also printed automatically in the left quiet zone.

Start/Stop Codes

The start/stop codes are special character codes marking those portions of the bar code. These codes are automatically provided.

Number System Character

The number system character field for all UPC-E and UPC-E0 bar codes must be zero.

Data Field

The bar code symbol uses a series of varying width bars and spaces to represent a limited character set (numbers 0-9 and Special Characters Start and Stop). The bars and spaces vary in width from one through four modules. Each character consists of two bars and two spaces that total seven modules.

For UPC-E, eleven digits are expected, which are compressed down to the six encoded symbol characters. For UPC-E0, six compressed digits are expected.

The optional 2- or 5-digit add-on data field is placed at the end of the bar code and typically identifies a periodical issue number or price, respectively.

Readable Data

The human readable data field provides a readable interpretation of the bar code data. It can either be suppressed or printed above or below the bar code symbol.

Check Digit

The modulo-10 check digit is automatically calculated and inserted in the bar code symbol. The check digit verifies accurate scanning. The number system character is included in the check digit algorithm.

UPC-E Command Format

BARCODE

type [+*n*]; [*DIR*;] [*MAG*;] [*Hn* [. *m*];] [*BFn*;] [*DARK*;] *SR*; *SC*
 [(*D*)*data field*(*D*)]
 [*PDF* [:*LOC*] [:*FONT*]]
 STOP

- BARCODE** The Bar Code command; enter **BARCODE**.
- type* Designates bar code type UPC-E or UPC-E0; enter **UPC-E** or **UPC-E0**.
- +*n* Optional parameter to provide a 2- or 5-digit add-on code at the end of the bar code. Enter plus (+) and a value of **2** or **5**. The first bar of the add-on code is separated by nine modules from the last bar of the UPC symbol and a left guard pattern.
- DIR* Optional parameter that allows for rotating a barcode. Enter **CW** for clockwise rotation. Enter **CCW** or **VSCAN** for counter-clockwise rotation. Enter **INV** for inverted rotation. If *DIR* is not entered, the barcode is horizontally oriented.
- MAG* Optional parameter to magnify (horizontally expand) the bar code symbol. The magnification default value is **X1**. Enter a magnification value from Table 8 to increase the magnification. Increasing the magnification adjusts printed character density. You can also use XR or XRD as defined on page 89. (You must specify 8 digits for *MAG* for variable ratio.)
- Hn* [. *m*] Optional parameter to adjust the overall height (vertical expansion) of the bar code symbol (including the upper and lower 0.1-inch guard bands and any human readable data). Height adjustments are made in 0.1-inch increments; enter **H** and a value from **4** through **99** to select height adjustments from 0.4 through 9.9 inches. The default value is 1.3 inches. The [. *m*] provides an additional number of dots for the bar code height. (Dots are in the current dot scale.)
- BFn* Optional parameter for assigning a dynamic bar code data field location on a form. With this parameter, the actual data for the bar code data field is provided dynamically during the Execute Form mode; the data is not specified during the Create Form mode. To use this field:
- Enter **BF**.
 - Replace *n* with a number ranging from **1** through **512** to identify the bar code field. The *SR* and *SC* parameters specify the exact location of the bar code field identified by *n*.

- c. The length of the data field need not be specified, since it is fixed at 6 or 11 digits, plus any add-on data.
 - d. The information for the data field is entered dynamically during the Execute Form mode. (Refer to “Execute Form: Dynamic Bar Code Data” on page 63.) Do not use the *data field* parameter to enter data when the *BFn* parameters are used. However, refer to the *data field* description for available characters.
- DARK** Optional parameter to produce darker bar codes. Enter **DARK**. Refer to “Dark Printing” on page 28 for more information.
- SR** Defines the starting row for the bar code. Enter a value ranging from row 1 to one less than the length of the form. Character row or dot row is specified based on the Scale command (page 83), or use the CP.DP format (page 26).
- SC** Defines the starting column of the bar code. Enter a value ranging from column 1 to one less than the width of the form. Character column or dot column is specified based on the Scale command (page 83), or use the CP.DP format (page 26).
- (D)** The printable character (delimiter) identifying the start and finish of the data field. Enter any printable character other than a slash (/), the SFCC, or a character used within the data. The same character must be used at both ends of the data field but it will not print with the data.
- data field*** The characters available for the data field are 0 through 9 (30 through 39 hex, respectively).
 For UPC-E, eleven digits are expected: Enter the number system character first by entering **0**; followed by the five-digit manufacturer number; ending with the five-digit item number. The manufacturing number and item number sequences must conform to one of the number pattern sequences shown in Table 18.
 The IGP will compress the 11 characters of data down to the six encoded UPC-E symbol characters. Include the 2- or 5-digit add-on data at the end of this data field.
 For UPC-E0, six digits are expected. These six digits must be a valid compressed UPC-E number. Otherwise, Error 96 will be generated.

PDF	Optional parameter which affects printing of the human readable data field. The data field will print automatically unless the PDF-suppress command is specified in the <i>FONT</i> parameter. UPC-E data fields can be printed above or below the bar code symbol. If the PDF is not entered in the UPC-E command format, the data field automatically prints in OCR-B.
LOC	Optional parameter to identify the location of the printable data field. The default value is B , locating the human readable data below the bar code. A locates the printable data field above bar code. To compensate for printing the 0.1-inch high data, the height of the bar code body is reduced 0.1-inch.
FONT	Optional parameter to select the font for the human readable data field. The default font type for UPC-A bar codes is OCR-B; if no PDF command is entered in the command format, the data field is printed automatically in OCR-B. Entering X will also designate the OCR-B type font. Enter N to select the normal ASCII 10 cpi font; enter O to select the OCR-A 10 cpi font. Enter P to select 12 cpi. Enter Q to select 13 cpi. Enter R to select 15 cpi. Enter T to select 17 cpi. Enter V to select 20 cpi. Enter S to suppress printing the data field and the trailing lower portions of the UPC bar code.
STOP	Ends the Bar Code command while the IGP continues in the Create Form mode. Enter STOP . If STOP is not entered, an error message results.

Table 18. Eleven-Digit Compression

1. Manufacturer's Number					Product Numbers that can be used 00000-00999		
<u>X</u>	<u>X</u>	<u>0</u>	<u>0</u>	<u>0</u>	(_ _)	(_ _ _)	(_)
<u>X</u>	<u>X</u>	<u>1</u>	<u>0</u>	<u>0</u>	first two digits of	last three digits of	third digit of the
<u>X</u>	<u>X</u>	<u>2</u>	<u>0</u>	<u>0</u>	manufacturer's	the product number	manufacturer's
					number		number, use 0
							through 2 only

2. Manufacturer's Number					Product Numbers that can be used 00000-00999		
<u>X</u>	<u>X</u>	<u>3</u>	<u>0</u>	<u>0</u>	(_ _ _)	(_ _)	(<u>3</u>)
<u>X</u>	<u>X</u>	<u>9</u>	<u>0</u>	<u>0</u>	first three digits of	last two digits of the	depends on how
					manufacturer's	product number; use	many digits appear
					number	00-99 only	in the
							manufacturer's
							number

3. Manufacturer's Number					Product Numbers that can be used 00000-00999		
<u>X</u>	<u>X</u>	<u>X</u>	<u>X</u>	<u>0</u>	(_ _ _ _)	(_)	(<u>4</u>)
					first four digits of	last digit of product	depends on how
					manufacturer's	number, use 0	many digits appear
					number	through 9 only	in the
							manufacturer's
							number

4. Manufacturer's Number					Product Numbers that can be used 00000-00999		
<u>X</u>	<u>X</u>	<u>X</u>	<u>X</u>	<u>X</u>	(_ _ _ _ _)	(_)	
					all five digits of	last digit of product	
					manufacturer's	number, use 5-9	
					number	only	

Table 19. Six-Digit Zero Expansion

if the 6 digit number ends with:	then the MFPS number is:	and the Product Number is:
0 Example: 124560	the first 2 digits (of the zero suppressed number) plus <u>000</u> 12000	00 plus the THIRD, FOURTH and FIFTH digit (of the zero suppressed number) 00456
1 Example: 275831	the first two digits plus <u>100</u> 27100	same as above 00583
2 Example: 412022	the first two digits plus <u>200</u> 41200	same as above 00202
3 Example: 876543	the first three digits plus <u>00</u> 87600	000 plus the FOURTH and FIFTH digit 00054
4 Example: 753774	the first four digits plus <u>0</u> 75370	0000 plus the FIFTH digit 00007
5, 6, 7, 8, 9 Examples: 213756 517019	the first five digits of the zero suppressed number 21375 51701	0000 plus the SIXTH digit 00006 00009

UPC-E Example

Figure 41 illustrates a horizontal and vertical UPC-E bar code generated by the following program:

```

~CREATE ;UPCE
BARCODE
UPC-E+2 ;H9 ;D ; 34 ; 15
*0927400000522*
PDF
STOP
END
~EXECUTE ;UPCE ; 1

~NORMAL
    
```

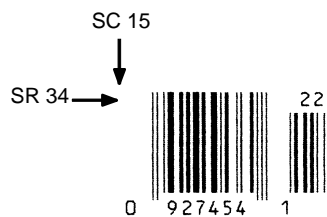

Figure 41. Sample UPC-E Bar Code

UPCSHIP

The structure for the UPCSHP bar code is shown in Figure 42 and described on the following pages.

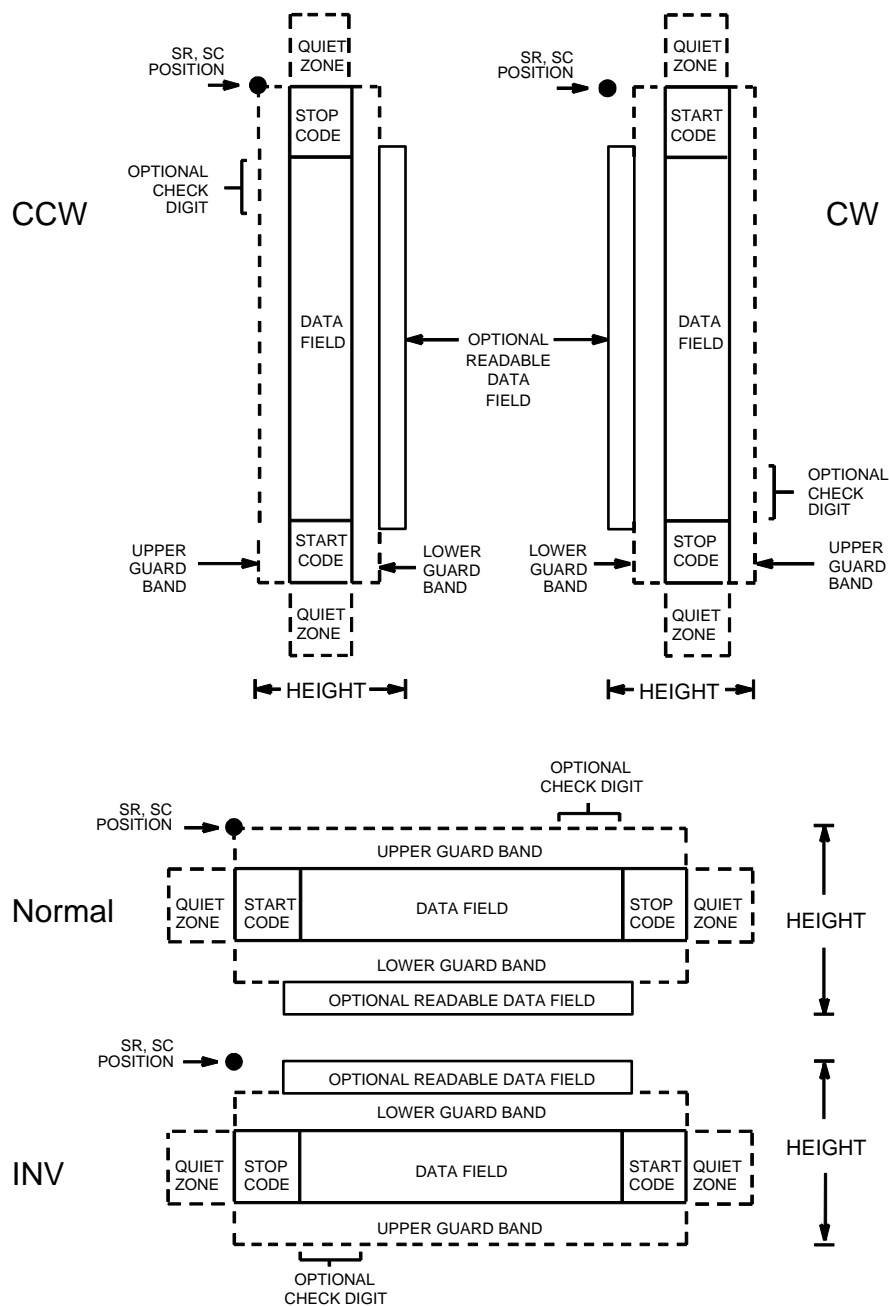

Figure 42. UPCSHP Structure

Quiet Zone

Both ends of the bar code structure have blank quiet zones. The quiet zones must be at least 0.25 inches wide and completely blank to ensure accurate reading of the start/stop codes and to prevent adjacent bar codes from overlapping. You must provide sufficient space on the form for the quiet zones.

Start/Stop Codes

Unique start and stop codes permit bidirectional scanning. Both start and stop codes contain bars and spaces. They are automatically produced.

Data Field

The bar code symbol uses a series of wide and narrow bars and spaces to represent numeric characters. The structure is 2 wide elements (bars or spaces) and 3 narrow elements. The UPCSHP barcode must contain exactly 13 digits of numeric data.

Readable Data

The optional readable data field provides a readable interpretation of the bar code data. It can be printed above or below the bar code symbol.

Check Digit

The modulo-10 check digit is inserted automatically into the bar code to verify accurate scanning.

UPCSHIP Command Format

BARCODE

UPCSHIP; [*DIR*]; [*MAG*]; [*Hn*].*m*]; [*BF**n*]; [*DARK*]; *SR*; *SC*
(*D*)*data field*(*D*)

[*PDF* [;*LOC*] [;*FONT*]]

STOP

BARCODE The Bar Code command; enter **BARCODE**.

UPCSHIP Designates bar code type UPCSHP; enter **UPCSHIP**.

DIR Optional parameter that allows for rotating a barcode. Enter **CW** for clockwise rotation. Enter **CCW** or **VSCAN** for counter-clockwise rotation. Enter **INV** for inverted rotation. If *DIR* is not entered, the barcode is horizontally oriented.

MAG Optional parameter to magnify (horizontally expand) the bar code symbol. The magnification default value is **X1**. As required for scanning, enter a magnification value from Table 8 to increase the magnification. Increasing the magnification adjusts printed character density. You can also use **XR** or **XRD** as defined on page 89.

Hn].*m*] Optional parameter to adjust the overall height (vertical expansion) of the bar code symbol (including the upper and lower 0.1-inch guard bands and any human readable data). Height adjustments are made in 0.1-inch increments; enter **H** and a value from **3** through **99** to select height adjustments from 0.3 through 9.9 inches. The default value is 0.9-inch.
[*m*] is an additional number of dots for the bar code height. (Dots are in the current dot scale.)

NOTE: If 0.3 inches is the selected height, the PDF cannot be included.

*BF**n* Optional parameter for assigning a dynamic bar code data field location on a form. With this parameter, the actual data for the bar code data field is dynamically provided during the Execute Form Mode; the data is not specified during the Create Form Mode. To use this field, perform the following steps:

- a. Enter **BF**.
- b. Replace *n* with a number ranging from **1** through **512** to identify the bar code field. The *SR* and *SC* parameters specify the exact location of the bar code field identified by *n*.
- c. The length of the data field need not be specified, since it is fixed at 13 digits, plus any add-on data.

- d. The information for the data field is entered dynamically during the Execute Form Mode. (Refer to “Execute Form: Dynamic Bar Code Data” on page 63.) Do not use the *data field* parameter to enter data when the *BFn* parameters are used. However, refer to the *data field* description for available characters.
- DARK** Optional parameter to produce darker looking bar codes. Enter **DARK**. Refer to “Dark Printing” on page 28 for more information.
- SR** Defines the starting row for the bar code. Enter a value ranging from row 1 to one less than the length of the form. Character row or dot row is specified based on the Scale command (page 89), or use the CP.DP format (page 26).
- SC** Defines the starting column of the bar code. Enter a value ranging from column 1 to one less than the width of the form. Character column or dot column is specified based on the Scale command (page 89), or use the CP.DP format (page 26).
- (D)** The printable character (delimiter) identifying the start and finish of the data field. Enter any printable character other than a slash (/), the SFCC, or a character used within the data. The same character must be used at both ends of the data field, but it will not print with the data.
- data field* The barcode data. The UPCSHP barcode requires exactly 13 characters of data. The available characters are 0 through 9 (hex 30 through hex 39). The modulo-10 check digit is automatically included in the barcode.
- PDF** Optional parameter to enable printing of the human readable data field. Enter **PDF** to print the data field. If the parameter is not used, the human readable data is not printed.
- LOC** Optional parameter to identify the location of the printable data field. The default value is **B**, locating the human readable data below the bar code. **A** locates the printable data field above bar code. To compensate for printing the 0.1-inch high data, the height of the bar code body is reduced 0.1-inch.

FONT Optional parameter to select the font for the human readable data field. Enter **O** to select OCR-A font; enter **X** to select OCR-B font; enter **N** to select 10 cpi; enter **P** to select 12 cpi; enter **Q** to select 13 cpi; enter **R** to select 15 cpi; enter **T** to select 17 cpi; enter **V** to select 20 cpi.

STOP Ends the Bar Code command while the IGP/PGL continues in the Create Form Mode. Enter **STOP**. If **STOP** is not entered, an error message results.

UPCSHIP Example

```

~CREATE;UPCSHIP (Enter Create Form Mode)
BARCODE (Bar Code command)
UPCSHIP;H12;9;8 (UPCSHIP Bar Code, height 1.2 inches,
at SR 9, SC 8)
*0014154401171* (Data Field)
PDF (Print Data Field)
STOP (Ends Bar Code command)
BARCODE (New Bar Code command)
UPCSHIP;VSCAN;3;45 (Vertical UPCSHP Bar Code at SR 3, SC 45)
*1141281029432* (Data Field)
PDF;A (Print Data Field above the bar code)
STOP (Ends Bar Code command)
END (Terminates Create Form Mode)
~EXECUTE;UPCSHIP;1 (Execute the form, form count of 1)
    
```

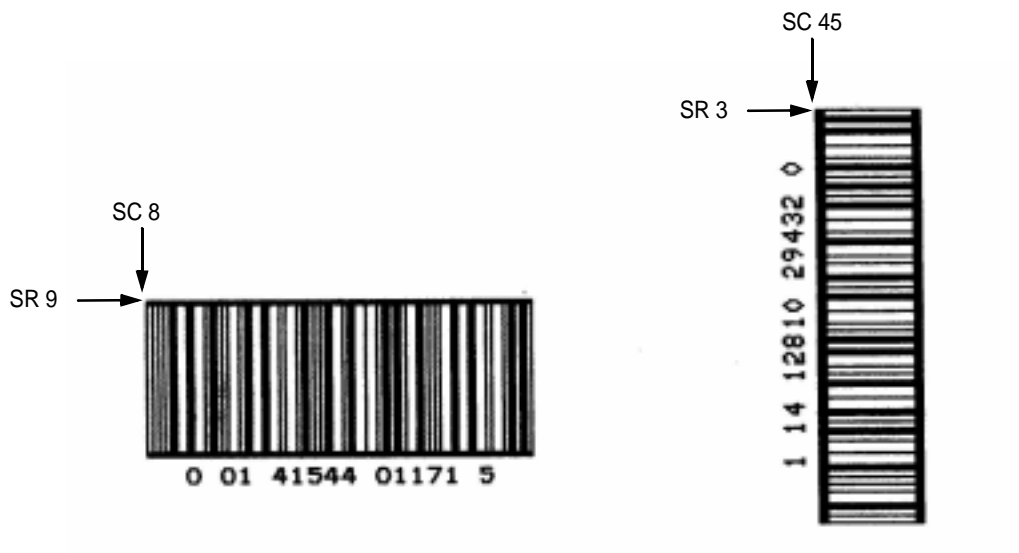

Figure 43. Sample UPCSHP Bar Codes

UPS 11

The UPS 11 structure is shown in Figure 44 and described on the following pages.

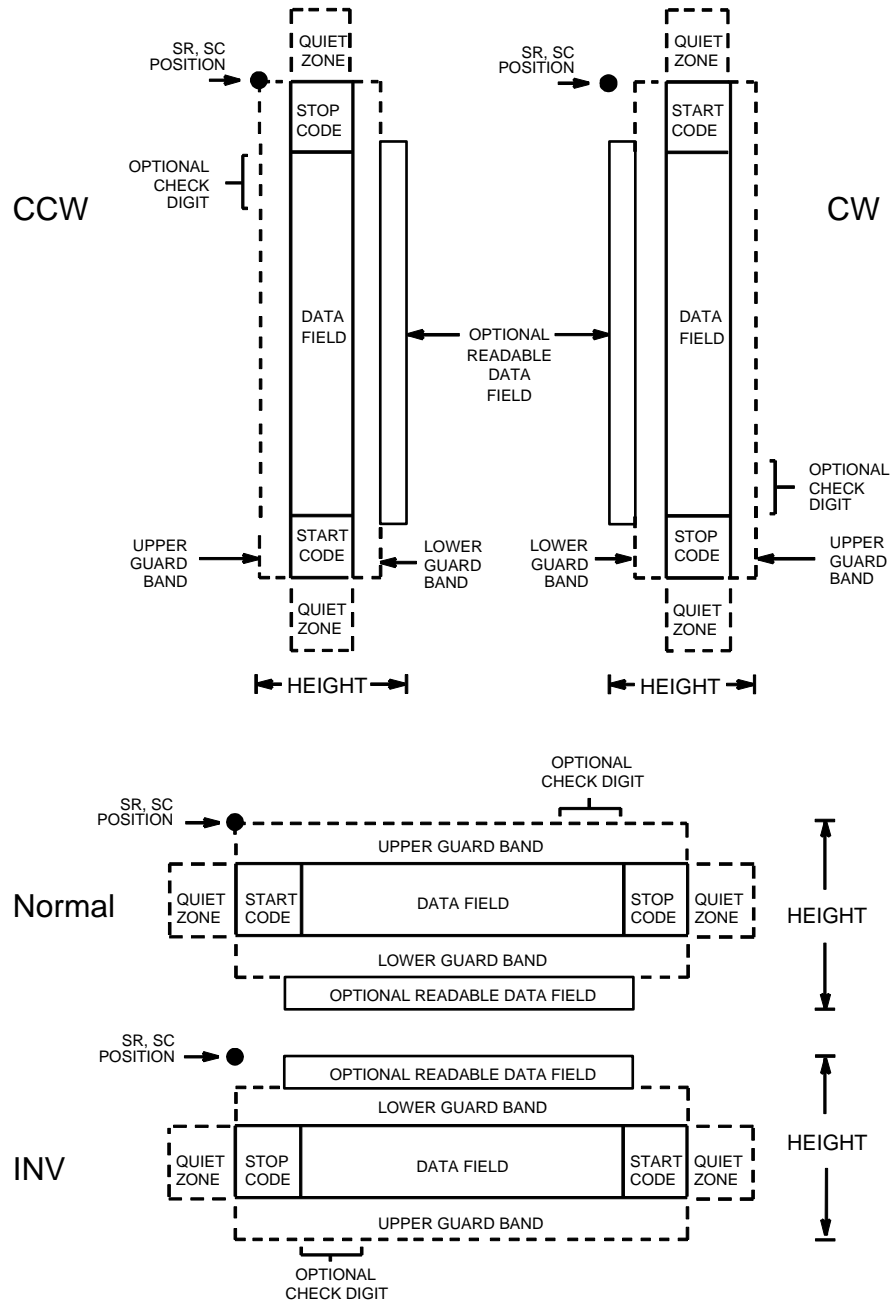

Figure 44. UPS 11 Structure

Quiet Zone

Both ends of the bar code structure require blank quiet zones. The quiet zones must be at least 0.25 inches wide and completely blank to ensure accurate reading of the start/stop codes and to prevent adjacent bar codes from overlapping. Be sure to provide sufficient space on the form for the quiet zones.

Start/Stop Codes

The start/stop codes identify the leading and trailing end of the bar code. Each of the UPS 11 subsets uses a unique start code and a common stop code, both automatically provided by the IGP/PGL.

Data Field

UPS 11 is a special case of Code 128 (page 108). This bar code is restricted to 10 data characters. The first character must be 0 through 9 or A through Z. The remaining nine digits must be 0 through 9.

Readable Data

The optional readable data field provides a readable interpretation of the bar code data. It can be printed above or below the bar code symbol.

Check Digit

The modulo-103 check digit is automatically calculated and inserted in the bar code symbol. The check digit verifies accurate scanning. The start code is included in the check digit algorithm.

UPS 11 Command Format

```

BARCODE
UPS11; [DIR;] [MAG;] [Hn;.m;] [BFn;L;] [DARK;] SR; SC
[(D)data field(D)]
[PDF [;LOC] [;FONT]]
STOP

```

BARCODE	The Bar Code command; enter BARCODE .
UPS11	Designates bar code type UPS 11; enter UPS11 .
<i>DIR</i>	Optional parameter that allows for rotating a barcode. Enter CW for clockwise rotation. Enter CCW or VSCAN for counter-clockwise rotation. Enter INV for inverted rotation. If <i>DIR</i> is not entered, the barcode is horizontally oriented.
<i>MAG</i>	Optional parameter to magnify (horizontally expand) the bar code symbol. The magnification default value is X1 . Increasing the magnification adjusts printed character density as shown in Table 8. You can also use XR or XRD as defined on page 89. (You must specify 8 digits for <i>MAG</i> for variable ratio.)

Hn[.m] Optional parameter to adjust the overall height (vertical expansion) of the bar code symbol (including the upper and lower 0.1-inch guard bands and any human readable data). Height adjustments are made in 0.1-inch increments; enter **H** and a value from **3** through **99** to select height adjustments from 0.3 through 9.9 inches. The default value is 0.9 inch.
[.m] is an additional number of dots for the bar code height. (Dots are in the current dot scale.)

Note

If 0.3 inches is the selected height, the PDF cannot be included.

BFn;L Optional parameters for assigning a dynamic bar code data field location on a form and for designating the length of the data field. With these parameters, the actual data for the bar code data field is dynamically provided during the Execute Form Mode; the data is not specified during the Create Form Mode. To use this field, perform the following steps.

- a. Enter **BF**.
- b. Replace *n* with a number ranging from **1** through **512** to identify the bar code field. The *SR* and *SC* parameters specify the exact location of the bar code field identified by *n*.
- c. Replace *L* with a number equaling the total number of characters in the field. (The actual data provided dynamically during the Execute Form Mode can be less than *L*.)
- d. The information for the data field is entered dynamically during the Execute Form Mode. (Refer to "Execute Form: Dynamic Bar Code Data" on page 63.) Do not use the *data field* parameter to enter data when the *BFn;L* parameters are used. However, refer to the *data field* description for available characters.

DARK Optional parameter to produce darker looking bar codes. Enter **DARK**. Refer to "Dark Printing" on page 28 for more information.

SR Defines the starting row for the bar code. Enter a value ranging from row 1 to one less than the length of the form. Character row or dot row is specified based on the Scale command (page 83), or use the CP.DP format (page 26).

<i>SC</i>	Defines the starting column of the bar code. Enter a value ranging from column 1 to one less than the width of the form. Character column or dot column is specified based on the Scale command (page 83), or use the CP.DP format (page 26).
<i>(D)</i>	The printable character (delimiter) identifying the start and finish of the data field. Enter any printable character other than a slash (/), the SFCC, or a character used within the data. The same character must be used at both ends of the data field, but it will not print with the data.
<i>data field</i>	Enter the data for the bar code. This bar code is restricted to 10 data characters. The first character must be 0 through 9 or A through Z. The remaining nine digits must be 0 through 9.
PDF	Optional parameter to enable printing of the human readable data field. Enter PDF to print the data field. If the parameter is not used, the human readable data will not print. This parameter is not allowed if a null data field was specified.
<i>LOC</i>	Optional parameter to identify the location of the printable data field. The default value is B , locating the human readable data below the bar code. A locates the printable data field above bar code. To compensate for printing the 0.1-inch high data, the height of the bar code body is reduced 0.1 inch.
<i>FONT</i>	Optional parameter to select the font for the human readable data field. Enter O to select OCR-A font; enter X to select OCR-B font; enter N to select 10 cpi; enter P to select 12 cpi; enter Q to select 13 cpi; enter R to select 15 cpi; enter T to select 17 cpi; enter V to select 20 cpi.
STOP	Ends the Bar Code command while the IGP/PGL continues in the Create Form Mode. Enter STOP . If STOP is not entered, an error message results.

Note

Access for the alternate set of control function characters is by using SO (Shift Out, hex 0E). The SO control code identifies the next character as the control function character, and must be inserted before *each* alternate character required. The SO character is selectable from the printer's front panel (see your *User's Guide*).

UPS 11 Example

Figure 45 illustrates a vertical UPS 11 bar code generated by the following program:

```
~CREATE;UPS11  
BARCODE  
UPS11;VSCAN;H9;34;15  
*01234567895*  
PDF  
STOP  
END  
~EXECUTE;UPS11;1  
  
~NORMAL
```

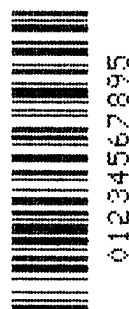

Figure 45. Sample UPS 11 Bar Code

Incremental Bar Code Fields

With the incremental bar code fields feature, you can update bar code (and alphanumeric) data fields in a numeric or alphabetical manner automatically with just one set of data sent from the host computer. You can print up to 65,535 forms with incremental fields automatically updated.

Note

Throughout the discussion of incremental fields, the term “increment” or “incremental” means the field is automatically updated by a specified amount (or increment). You can actually increment the field by a positive amount (added) or a negative amount (subtracted) as specified within the command.

You can use bar code incremental fields with fixed (static) data input as part of the Create Form mode, or with dynamic data supplied in the Execute Form mode. New formats and parameters are required in the bar code commands for static and dynamic incremental fields. In addition, the Execute Form command requires a new format and parameters when you use incremental fields with dynamic data. You can increment or decrement incremental fields, repeat at specified intervals before updating, and reset to the starting value after a specified number of increments.

Incrementing Bar Code Data

The IGP internally counts incremental static (fixed) bar code data fields. A maximum of 255 incremental fixed bar code data fields are allowed per form.

Incrementing is controlled with the STEPMASK and STARTDATA command parameters as described in Table 20. The parameters are part of the bar code command or part of the Execute command when using the Incremental Bar Code Dynamic Data command.

The STEPMASK parameter performs three functions:

1. It defines the increment amount (step);
2. It defines the number of characters allowed in the data field (STARTDATA); and
3. It provides a “mask” to link or unlink subfields of data for individual incremental activity. The data provided in the STEPMASK field combined with the data in the STARTDATA field determine the result of these functions.

Table 20. Incremental Bar Code Data

STEPMASK	STARTDATA	Character Type and Function
0-9	A-Z	Alpha characters are incremented by amount in STEPMASK field.
0-9	0-9	Numeric characters are incremented by amount in STEPMASK field.
0-9	Space	Same character type as character in the next right adjacent, linked increment position. Character type is numeric if in the least significant position.
0-9	Not A-Z or 0-9	Error
Not 0-9 or L	Any	Non-incrementing alphanumeric character.
L	Any	Linked, non-incrementing alphanumeric character.

The increment amount is defined by the numeric value of the STEPMASK data. For example, a STEPMASK value of 1 increments the STARTDATA by 1; a STEPMASK value of 2 increments the STARTDATA by 2.

The maximum number of characters allowed in the STARTDATA is defined by the number of characters in the STEPMASK field and depends on the specific type of bar code; the STARTDATA field cannot contain more characters than used in the STEPMASK field and can only contain the number and type of characters allowed by the bar code.

Linked and unlinked masking of subfields within the STARTDATA is defined by using the **L** value in the STEPMASK field. **L** indicates linked but nonincrementing data in the corresponding position of the STARTDATA field. Any alphanumeric character other than **L** in the STEPMASK field indicates a nonincrementing, non-linked STARTDATA subfield.

The following examples illustrate incrementing of bar code data fields. All cases in the examples use a repeat count parameter value of 1 and a reset count parameter value of 0. Incremental bar code data is generated identically to incremental alphanumeric data except the IGP does not add leading spaces to bar code data.

Note

In the following bar code examples, the *value* of the data is shown automatically incrementing. In practical applications, the bar code itself would print corresponding to the incremented data as shown in the Auto Increment Fields Example in the “Form Examples and Exercises” chapter.

	Value	Description
STARTDATA:	ABC123	<i>Linked subfields: ABC and 123</i>
STEPMASK:	000001	
Printed Results:	ABC123	<i>RPT = 1</i>
	ABC124	<i>RST = 0</i>
	
	
	
	ABC999	
	ABD000	
	
	
	
	ZZZ999	
	AAA000	

	Value	Description
STARTDATA:	1ABC123	<i>Two separate but linked numeric subfields: 1 and 123, while fixed data ABC is nonincrementing</i>
STEPMASK:	0LLL001	
Printed Results:	1ABC123	<i>RPT = 1</i>
	1ABC124	<i>RPT = 0</i>
	. . .	
	. . .	
	. . .	
	1ABC999	
	2ABC000	

	Value	Description
STARTDATA:	ABC123	<i>Two separate unlinked subfields: ABC and 3, while fixed data 1 and 2 is nonincrementing</i>
STEPMASK:	001XX1	
Printed Results:	ABC123	<i>RPT = 1</i>
	ABD124	<i>RPT = 0</i>
	. .	
	. .	
	. .	
	ABI129	
	ABJ120	

Incremental Bar Code Fixed Data Fields

The Incremental Bar Code Fixed Data Fields command is a variation of the standard IGP bar code commands. Use this command with the appropriate parameters from the standard bar code command when automatic incrementing of fixed bar code data fields is required. The Incremental Bar Code Fixed Data Fields command format is shown and defined below. (Incremental command parameters are shown in **boldface** type; standard bar code command parameters and optional nonincremental parameters are shown in *italics*.)

```

BARCODE
type; [VSCAN;] [MAG;] [Hn;] I; [DARK;] SR; SC
[idir] STEPMASK; [RPTn;] [RSTn;] (D)STARTDATA(D)
[PDF [;LOC] [;FONT]]
STOP

```

- I** Identifies this bar code command as an Incremental Bar Code command; enter **I**.
- idir*** The optional increment direction parameter to specify an increment (add) or decrement (subtract) to the data. Enter a plus sign (+) or leave the field blank to increment (the default). Enter a minus sign (-) to decrement.
- STEPMASK*** Defines the increment amount (step), number of character positions in the data field, and provides a mask to control the increment function on specific parts of the data. Refer to "Incrementing Bar Code Data" on page 208 for complete information on STEPMASK parameter values.
- RPTn*** The optional incremental repeat count parameter to specify the number of times a particular field value will repeat before it is incremented. A repeated field value is useful when printing multiple rows/columns of identical labels before increasing to the next value. To use the repeat count parameter, enter **RPT** and replace *n* with a numeric value ranging from 1 through 65,535 to specify the repeat count. The default repeat count parameter is 1, which will increment the field value each time it is printed.
- RSTn*** The optional incremental reset count parameter to specify the number of times an incremented field is printed (on one or more forms) before it is reset to the starting value. A reset count is useful when printing a hierarchy of fields where a low-level field generates a sequence of numbers, is reset, and the next higher field level is incremented (such as in a unit/box/carton application). To use the reset count parameter, enter **RST** and replace *n* with a number ranging from 1 through 65,535 to specify the reset count. The default reset count value is 0.

STARTDATA Defines the starting value of the incrementing field. The maximum amount of STARTDATA characters must be less than or equal to the number of characters in the STEPMASK field. Characters allowed for incrementing fields is based on the type of bar code; refer to the individual bar code descriptions for information on valid type and quantity of data characters. The STARTDATA must be enclosed within standard printable character delimiters just as a standard bar code data field is enclosed within delimiters.

```

~CREATE;TEST;288      (Enters Create Form mode)
VDUP;3;6
BARCODE              (Bar code command)
C3/9;H7;I;6;5
-00001;*12345*
PDF                  (Printable data field)
STOP                 (Ends bar code command)
VDUP;OFF
END                  (Terminates Create Form mode)
~EXECUTE;TEST        (Prints form)

~NORMAL

```



Incremental Bar Code Dynamic Data Fields

The Incremental Bar Code Dynamic Data Field command specifies the location and size of the incremental dynamic data field during the Create Form mode. STEPMASK and STARTDATA parameters are supplied in the Execute command during the Execute Form mode. As with standard dynamic data fields, incremental dynamic data fields allow you to change the starting data without changing the form definition program. Additionally, you can also change the increment parameters with each new job without changing the form definition program.

The Incremental Bar Code Dynamic Data Fields command is a variation of the standard IGP bar code commands. Use this command with the appropriate parameters from the standard Bar Code command when automatic incrementing of dynamic bar code data fields is required. The Incremental Bar Code Dynamic Data Fields command format is shown and defined below. (Incremental command parameters are shown in **boldface** type; standard bar code command parameters and optional nonincremental parameters are shown in *italics*.)

BARCODE

*type; [VSCAN;] [MAG;] [Hn;] **IBFn;L** [DARK;] SR; SC
[PDF [;LOC] [;FONT]]*

STOP

IBFn;L Identifies this bar code command as an Incremental Bar Code Dynamic Data Field command. The command parameter string identifies the incremental dynamic data field location on the form and defines the length of the bar code data.

Note



If these parameters are used, *do not* enter the STEPMASK and STARTDATA parameters in the Create Form mode; enter them dynamically during the Execute Form mode.

To use the incremental dynamic data field:

- a. Enter **IBF** to specify an incremental bar code dynamic data field.
- b. Replace *n* with a number ranging from **1** through **512** to identify the bar code string location on the form. The standard bar code *SR* and *SC* command parameters specify the exact location of the field identified by *n*.
- c. Replace *L* with a number equal to the number of characters in the dynamic bar code string (STARTDATA). The number of characters and type of characters depends on the type of bar code used. Refer to the individual bar code descriptions for information on type and quantity of data allowed for the specific bar code type.
- d. Dynamically enter the STEPMASK and STARTDATA parameters in the Execute Form mode. The length of the data must be less than or equal to the value assigned to the length (**L**) parameter. Refer to "Execute Form: Incremental Dynamic Data" on page 65 for more information.

Duplicating Incremental Bar Code Fields

Fixed and dynamic incremental bar code data fields are duplicated horizontally and vertically in the same way that incremental alphanumeric fixed and dynamic data fields are duplicated. Refer to page 40 for more information on duplicating incremental data.

```
~CREATE;TEST;288
VDUP;3;6
BARCODE
C3/9;H7;IBF1;6;D;6;5
PDF
STOP
VDUP;OFF
END
~EXECUTE;TEST
~IBF1;+000001;*123459*

-NORMAL
```



123459



123460



123461

4

Form Examples and Exercises

Form Examples

The following example demonstrates how to use Create commands in the Create Form mode using the CP.DP format. The printed output for this program is shown in Figure 46 on page 217. The box surrounding the form represents the paper size.

Note

If comment lines are used on command lines, they must be preceded by a slash (/). Do not use / comments on lines containing an SFCC (NORMAL, CREATE, EXECUTE, etc.). Comments in parentheses in this section are provided for better understanding of IGP operation but should not be included in your IGP files.

IMPORTANT

The examples in this chapter assume the Select Format command is already enabled (~SFON). When enabled, Select Format tells the IGP to ignore all host-generated paper movement commands (CR, LF, FF).

Example: Basic Create Form

```
~LISTEN
~LOGO;HAND;56;60
1;40-42
2;38-42
3;36-42
4;35-42
5;33-41
6;31-40
7;30-38
8;29-36
9;28-35
10;27-34;52-54
11;24-33;48-54
12;22-31;45-54
13;19-30;41-54
14;16-29;38-53
15;13-29;36-51
16;11-29;33-48
17;9-44
18;7-42
19;6-39
20;4-36
```

```
21;1-34
22;1-34
23;1-34
24;1-60
25;1-60
26;1-60
27;1-60
28;1-59
29;1-59
30;1-35
31;1-36
32;1-39
33;1-58
34;1-58
35;1-58
36;1-58
37;1-58
38;1-57
39;4-24
40;7-23
41;8-23
42;9-23
43;11-24
44;12-25
45;14-27
46;15-30
47;17-32
48;18-33
49;22-34
50;25-35
51;26-36
52;28-37
53;30-37
54;32-37
55;33-37
56;35-36
END
~CREATE;LEFTHAND
BOX
/LT;SR;SC;ER;EC
1;1;1;24;25
STOP
ALPHA
/[R[D][L];][E;][Cn;][AFn;L;][DIR;[UC;]DARK]SR;SC;VE;HE;(D)ASCII
TEXT(D)
3;3;0;0;*STATIC ALPHA DATA*
AF1;18;4;3;0;0
/DIR;SR;SC;VE;HE
CW;8;4;1;1;*Hewlett-Packard*
R;15;5;2;2;*IGP*
STOP
CORNER
/LT;SR;SC;ER;EC;VL;HL
1;18;2;23;7;2;2
STOP
HDUP;5;1
VERT
1;17;18;22
STOP
HDUP;OFF
VDUP;5;1
HORZ
1;18;17;21;1
```



```
STOP  
VDUP;OFF  
LOGO;LEFTHAND  
10;13;HAND  
STOP  
END  
~EXECUTE;LEFTHAND  
~AF1;*DYNAMIC ALPHA DATA*  
  
OVERLAY DATA  
~NORMAL
```

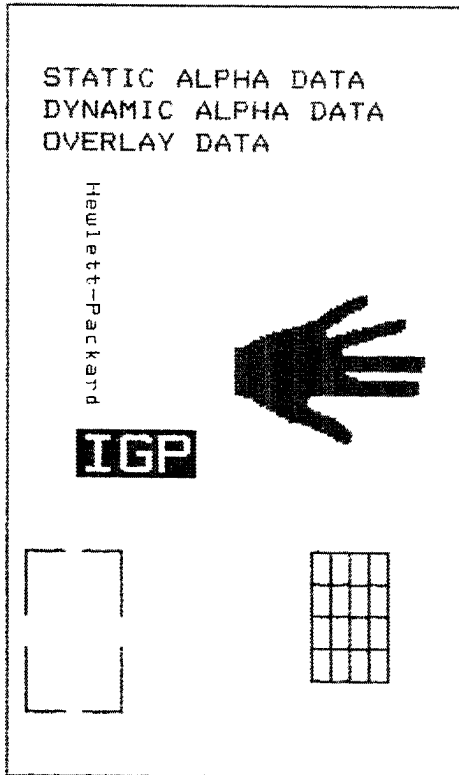

Figure 46. Basic Create Form Example

Example: Dynamic Data

The process of executing dynamic alphanumeric and bar code data fields is explained in the following exercises. Each stage includes printing the program; however, the total program may be entered as one unit. Each stage offers the option of choosing features applicable to specific needs.

Basic Design

The SAMPLE program below, shown in Figure 47, is a basic design in CP.DP format and defined by standard Create Form mode command sequences. The label is duplicated twice horizontally on an approximate form size of 8 1/2 x 5 1/2 inches, with three bar code locations specified per label. The result is two "forms": two labels per form, four labels printed on one 8 1/2 x 11 inch "page." On the next few pages, you will add bar code data, dynamic alphanumeric data, and dynamic bar code data. Then you will execute and print the complete form (Figure 48).

When entering command lines, remember to correctly terminate each line with a line feed or carriage return with line feed. Use your system commands to open a file for the label program. When you have finished, exit the file (if necessary for your system) and print.

```

~CREATE;SAMPLE;390
HDUP;2;37
BOX
2;3.5;9;30;35
STOP
HORZ
1;14.5;9;35
1;19.5;9;35
1;24.5;9;35
STOP
CORNER
2;4;11;9;33;1.2;2
2;9.6;11;13.6;33;1.2;2
STOP
ALPHA
4.8;12;0;0;*FROM:*
6.3;14;2;2;*ACME INC.*
C15;7.3;16;0;0;*17500 CARTWRIGHT RD*
C15;8.1;16;0;0;*IRVINE, CA 92714*
10;12;0;0;*TO*
14.8;11;0;0;*S.O.*
19.8;11;0;0;*S/N:*
24.8;11;0;0;*P/N:*
STOP
HDUP;OFF
END
~EXECUTE;SAMPLE;1

~NORMAL

```

FROM: ACME INC. 17500 CARTWRIGHT RD IRVINE, CA 92714
TO
S. O.
S/N:
P/N:

FROM: ACME INC. 17500 CARTWRIGHT RD IRVINE, CA 92714
TO
S. O.
S/N:
P/N:

FROM: ACME INC. 17500 CARTWRIGHT RD IRVINE, CA 92714
TO
S. O.
S/N:
P/N:

FROM: ACME INC. 17500 CARTWRIGHT RD IRVINE, CA 92714
TO
S. O.
S/N:
P/N:

Figure 47. Sample Form

Bar Code Fields

Identify the location of the data fields for each of the six bar codes (one location at each S.O., S/N, and P/N field on the form). The type of bar code and the human readable data information is also specified within the bar code commands. (Refer to the "Bar Codes" chapter for detailed bar code information.)

Each bar code must be designated separately. The bar code commands are part of the Create Form mode; therefore, they must be entered in the Create Form mode before the END command. However, because each dynamic field is assigned a unique number, the commands should not be duplicated. Reopen the file and input the following commands before the END command line but after the HDUP;OFF command.

Note



The IGP will horizontally or vertically duplicate dynamic bar code or alphanumeric data fields if required. This will also duplicate the *n* parameter identifying the dynamic data fields. If unique data fields are required, do not duplicate the commands.

```

BARCODE                (First bar code command)
                        (Upper left S.O. field, assigned number 1)
C3/9;H7;BF1;8;DARK;15.1;10.4
PDF;O                  (Print the data field in OCR-A font)
STOP                   (Stop the first bar code command)
BARCODE                (New bar code command)
                        (Upper left S/N field, assigned number 2)
C3/9;H7;BF2;8;DARK;20;10.4
PDF;O
STOP
BARCODE                (Upper left P/N field, assigned number 3)
C3/9;H7;BF3;8;DARK;25.5;10.4
PDF;O
STOP
BARCODE                (Upper right S.O. field, assigned number 4)
C3/9;H7;BF4;8;DARK;15.1;47.4
PDF;O
STOP
BARCODE                (Upper right S/N field, assigned number 5)
C3/9;H7;BF5;8;DARK;20;47.4
PDF;O
STOP
BARCODE                (Upper right P/N field, assigned number 6)
C3/9;H7;BF6;8;DARK;25.5;47.4
PDF;O
STOP                   (Stop the bar code command)

```

Dynamic Alphanumeric Fields

Identify the location of the dynamic alphanumeric fields using the alphanumeric command. Input the following alphanumeric command lines after the HDUP;OFF command and before the Create Form mode END line. A separate alphanumeric command sequence is used in order to assign unique numbers to each dynamic data field. If unique identifying numbers were not required, these alphanumeric commands would be added to the existing alphanumeric commands being duplicated to produce the fixed form alphanumeric data.

Note

Before the following dynamic data commands can be entered, delete the form count parameter from the existing Execute command line (the ;1 at the end of the Execute command line shown on the program on page 218). The Form Count parameter cannot be used when data is supplied dynamically. The Execute command line should now read ~EXECUTE;SAMPLE and must be correctly terminated. This is the Execute command for the first page of dynamic data.

```
ALPHA                (Begin alpha command for dynamic data)
AF1;20;10.8;12;0;0   (AF1=the first line of upper left TO area)
AF2;20;11.8;12;0;0   (AF2=second line of upper left TO area)
AF3;20;12.8;12;0;0   (AF3=third line of upper left TO area)
AF4;20;10.8;49;0;0   (AF4=first line of lower left TO area)
AF5;20;11.8;49;0;0   (AF5=second line of lower left TO area)
AF6;20;12.8;49;0;0   (AF6=third line of lower left TO area)
STOP                 (Stop the alphanumeric command)
```

Dynamic Alphanumeric and Bar Code Data

Enter the dynamic data following the Execute command. These dynamic data commands will supply the variable data to the bar code and alphanumeric fields previously identified in the Create Form mode. After entering the data, exit the file (if necessary with your system) and print. The completed form is shown in Figure 48.

```

~CREATE;SAMPLE;390
HDUP;2;37
BOX
2;3.5;9;30;35
STOP
HORZ
1;14.5;9;35
1;19.5;9;35
1;24.5;9;35
STOP
CORNER
2;4;11;9;33;1.2;2
2;9.6;11;13.6;33;1.2;2
STOP
ALPHA
4.8;12;0;0;*FROM:*
6.3;12;2;2;*ACME MOTOR*
C15;7.3;16;0;0;*17500 CARTWRIGHT RD*
C15;8.1;16;0;0;*IRVINE, CA 92714*
10;12;0;0;*TO*
14.8;11;0;0;*S.O.*
19.8;11;0;0;*S/N:*
24.8;11;0;0;*P/N:*
STOP
HDUP;OFF
BARCODE
C3/9;H7;BF1;8;DARK;15.1;10.4
PDF;0
STOP
BARCODE
C3/9;H7;BF2;8;DARK;20;10.4
PDF;0
STOP
BARCODE
C3/9;H7;BF3;8;DARK;25.5;10.4
PDF;0
STOP
BARCODE
C3/9;H7;BF4;8;DARK;15.1;47.4
PDF;0
STOP
BARCODE
C3/9;H7;BF5;8;DARK;20;47.4
PDF;0
STOP
BARCODE
C3/9;H7;BF6;8;DARK;25.5;47.4
PDF;0
STOP
ALPHA
AF1;20;10.8;12;0;0
AF2;20;11.8;12;0;0
AF3;21;12.8;12;0;0
AF4;20;10.8;49;0;0
AF5;20;11.8;49;0;0



```



```
AF6;20;12.8;49;0;0
STOP
END
~EXECUTE;SAMPLE
~AF1;*B AND C CO*
~AF2;*P.O. BOX 212*
~AF3;*LOS ANGELES, CA 90051*
~AF4;*M.H. INC.*
~AF5;*101 BEACH RD.*
~AF6;*MALIBU, CA 97772*
~BF1;*S05995*
~BF2;*011233*
~BF3;*190204*
~BF4;*S05996*
~BF5;*000535*
~BF6;*104523*
```



```
~NORMAL
~EXECUTE;SAMPLE
~AF1;*ABC CORPORATION*
~AF2;*1234 ANYWHERE ST.*
~AF3;*YOUR TOWN, MA 03498*
~AF4;*XYZ COMPUTERS*
~AF5;*845 N. ALLEN ST.*
~AF6;*WEST BEND, OR 97601*
~BF1;*S05997*
~BF2;*456789*
~BF3;*102245*
~BF4;*S05999*
~BF5;*567890*
~BF6;*103764*
```

```
~NORMAL
```

Multiple page documents must be separated by a form feed (the “page” of data includes the Execute command, the dynamic data commands, and the Normal command). Using the SFON command (described on page 84), a ~FF (form feed) command will allow as many forms as required to print with the appropriate new data supplied dynamically. When the SFOFF command is used, send a hex 0C instead of ~FF to print multiple pages with new dynamic data.

FROM: ACME MOTOR 17500 CARTWRIGHT RD IRVINE, CA 92714
TO: B AND C CO. P. O. BOX 212 LOS ANGELES, CA 90051
S. O.  S05995
S/N:  011233
P/N:  190204

FROM: ACME MOTOR 17500 CARTWRIGHT RD IRVINE, CA 92714
TO: M. H. INC. 101 BEACH RD. MALIBU, CA 97772
S. O.  S05996
S/N:  000535
P/N:  104523

FROM: ACME MOTOR 17500 CARTWRIGHT RD IRVINE, CA 92714
TO: ABC CORPORATION 1234 ANYWHERE ST. YOUR TOWN, MA 03498
S. O.  S05997
S/N:  456789
P/N:  102245



FROM: ACME MOTOR 17500 CARTWRIGHT RD IRVINE, CA 92714
TO: XYZ COMPUTERS 845 N. ALLEN ST. WEST BEND, OR 97601
S. O.  S05999
S/N:  567890
P/N:  103764

Figure 48. Dynamic Data Example

Example: Auto Increment Fields

The following program, designed in accordance with current specifications for AIAG-B-3 shipping label standards, creates four automatically incrementing/decrementing AIAG labels with alphanumeric and bar code data. The printed output of this program is shown on page 227.





```

~CREATE;AIAG
BOX
1;31.2;1;55.2;66.5
STOP
HORZ
1;38.5;1;66.5
1;44.9;1;40
1;49.10;1;40
STOP
VERT
1;26;38.5;44.9
1;40;44.9;55.2
STOP
ALPHA
C15;31.8;2;0;0;*PART NO*
C15;32.6;2;0;0;*(P)*
I;34.3;9;4;4;00000000002;*A0000000002*
C15;38.9;2;0;0;*QUANTITY*
C15;39.6;2;0;0;*(Q)*
40.5;8;4;4;*100*
C15;41.9;28;0;0;*SPECIAL*
C15;42.6;28;0;0;*(C)*
I;43.9;34;4;4;-00002;*A20UF*
C15;45;2;0;0;*SUPPLIER*
C15;45.10;2;0;0;*(V)*
45.7;7;2;2;* 040898755*
C15;50.4;2;0;0;*SERIAL*
C15;51.2;2;0;0;*(S)*
50.8;7;2;2;* 0002110*
C15;54.5;4;0;0;*ACME MOTOR, INC IRVINE CA 92713 (714) 863-1900*
STOP
BARCODE
C3/9;H7;I;DARK;34.7;5.5
X000000002;*A000000002*
STOP
BARCODE
C3/9;H7;DARK;40.9;5.5
*Q100*
STOP
BARCODE
C3/9;H7;I;DARK;38.1;33
-X00002;*CA20UF*
STOP
BARCODE
C3/9;H7;DARK;45.11;5.5
*V040898755*
STOP
BARCODE
C3/9;H7;DARK;50.9;5.5
*S0002110*
STOP
BOX
1;1.2;1;25.2;66.5
STOP
HORZ
1;8.4;1;66.5

```

```
1;14.9;1;40
1;19.6;1;40
STOP
VERT
1;26;8.4;14.9
1;40;14.9;25.2
STOP
ALPHA
C15;1.8;2;0;0;*PART NO*
C15;2.6;2;0;0;*(P)*
I;4.3;9;4;4;00000000002;*A0000000001*
C15;8.9;2;0;0;*QUANTITY*
C15;9.6;2;0;0;*(Q)*
10.5;8;4;4;*100*
C15;11.9;28;0;0;*SPECIAL*
C15;12.6;28;0;0;*(C)*
I;13.9;34;4;4;-00002;*A20UG*
C15;15;2;0;0;*SUPPLIER*
C15;15.10;2;0;0;*(V)*
15.6;7;2;2;* 040898755*
C15;20;2;0;0;*SERIAL*
C15;21;2;0;0;*(S)*
20.5;7;2;2;* 0002110*
C15;24.5;4;0;0;*ACME MOTOR,INC. IRVINE CA 92713 (714) 863-1900*
STOP
BARCODE
C3/9;H7;I;DARK;4.7;5.5
X000000002;*A000000001*
STOP
BARCODE
C3/9;H7;DARK;10.9;5.5
*Q100*
STOP
BARCODE
C3/9;H7;I;DARK;8.1;33
-X00002;*CA20UG*
STOP
BARCODE
C3/9;H7;DARK;15.7;5.5
*V040898755*
STOP
BARCODE
C3/9;H7;DARK;20.8;5.5
*S0002110*
STOP
END
~EXECUTE;AIAG;2

~NORMAL
```

PART NO (P) A000000001 	
QUANTITY (Q) 100 	SPECIAL (S)  A20UG
SUPPLIER (S) 040898755 	
SERIAL (S) 0002110  <small>ACME MOTOR, INC. IRVINE, CA 92713 (714) 863-1900</small>	

PART NO (P) A000000002 	
QUANTITY (Q) 100 	SPECIAL (S)  A20UF
SUPPLIER (S) 040898755 	
SERIAL (S) 0002110  <small>ACME MOTOR, INC. IRVINE, CA 92713 (714) 863-1900</small>	

PART NO (P) A000000003 	
QUANTITY (Q) 100 	SPECIAL (S)  A20UE
SUPPLIER (S) 040898755 	
SERIAL (S) 0002110  <small>ACME MOTOR, INC. IRVINE, CA 92713 (714) 863-1900</small>	

PART NO (P) A000000004 	
QUANTITY (Q) 100 	SPECIAL (S)  A20UD
SUPPLIER (S) 040898755 	
SERIAL (S) 0002110  <small>ACME MOTOR, INC. IRVINE, CA 92713 (714) 863-1900</small>	

Figure 49. Auto Increment Fields Example

Form Exercise

In the following example, you will create and execute a form. Using character scaling (discussed in detail on page 83) on a 60 x 72 dot per inch (dpi) grid, your form will include the following:

- a box
- a set of corners
- vertical lines
- alphanumeric data
- horizontal lines
- a bar code

This exercise will help you become familiar with the IGP by taking you through 14 steps to build a complete form. Detailed command descriptions for producing forms, bar codes, and logos are described in the “Commands” chapter.

All the data and commands for the form are entered into a file in the host computer. The filename used in this exercise is PRACTC.FRM, and the form name used is PRACTICE. If another form named PRACTICE already exists, it will be deleted by this exercise.

Begin each step by reading the explanation. The information you input is listed under the word **Enter**. The parameters of each command have a specific order for data entry; input the data exactly as shown, but always use the actual SFCC required by your system where the ~ is shown. The general command format is listed under the word **Format** next to each example. The SFCC is represented by (cc) in the general format.

Use the standard commands on your system to open, close, or print the file with the form data where your system format is required.

Note



Do not forget to terminate each command line with a line feed (or carriage return with line feed), or a paper motion command. Enter all commands in uppercase. Make sure the printer power is on and the printer is ONLINE.

Creating a Box and Corners

1. On your host computer, open/create a file for your practice form. For example:

Enter

PRACTC.FRM

Format

(system format)

2. Enter the Create Form mode, and specify a form name. This is the first input for every new form. Use the Create command and PRACTICE as the form name.

Enter

~CREATE;PRACTICE

Format

(cc)CREATE[/];formname[;FL]

- The IGP is now ready for Create Form mode commands. Design a box with a line thickness (*LT*) of 2 dots, a top left corner at starting row (*SR*) 35, starting column (*SC*) 16, and a bottom right corner at ending row (*ER*) 53, ending column (*EC*) 61. The STOP command must be entered to inform the IGP that the Box command is complete.

Enter	Format
BOX	BOX
2;35;16;53;61	<i>LT;SR;SC;ER;EC</i>
STOP	STOP

- Use the Corner command to set the box off with corners having a line thickness (*LT*) of 3 dots, a top left corner at row (*SR*) 30, column (*SC*) 13, a bottom right corner at row (*ER*) 57, column (*EC*) 64, a vertical length (*VL*) 5 character spaces long, and a horizontal length (*HL*) 7 character spaces long. The STOP command must be entered to stop the Corner command and END must be entered to terminate the Create Form mode to prepare for printing.

Enter	Format
CORNER	CORNER
3;30;13;57;64;5;7	<i>LT;SR;SC;ER;EC;VL;HL</i>
STOP	STOP
END	END

- Now use the Execute command and form name to prepare for printing. Enter a blank line using a terminator and then the Normal command to instruct the IGP to return to the Normal mode after executing the form.

Enter	Format
~EXECUTE;PRACTICE	(cc)EXECUTE; <i>formname</i> [:PAGE <i>n</i>][:FC]
~NORMAL	(cc)NORMAL

- To print the form, exit the file (if necessary for your system) and use the system print command to print the file. For example, after exiting the file and your system prompt returns:

Enter	Format
.PRINT PRACTC.FRM	(System Format)

The form should look like the one shown in Figure 50. When it was printed, the form program was stored in the IGP memory. If errors are detected in the program, error messages are printed and only the error-free portions of the program are stored in the IGP memory. Refer to "Solving Program Errors" on page 248.

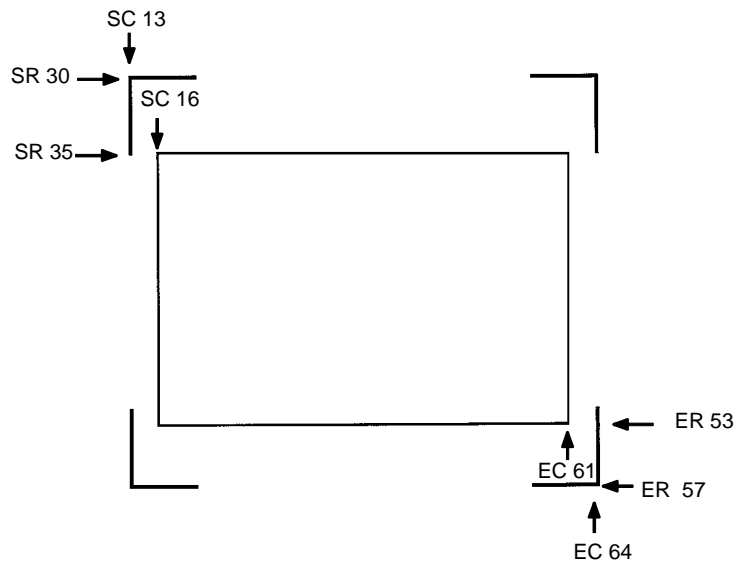

Figure 50. Box and Corner Example

Adding Horizontal and Vertical Lines

7. Now return to the file. When the file reopens, the existing program (the contents of the file) is displayed. Use your system commands to reopen the file. For example:

Enter	Format
.PRACTC.FRM	(System Format)

8. All Create Form mode commands must be entered into the program before the End command line. Add three horizontal lines, each with a thickness (*LT*) of 1 at rows (*R*) 40, 45, and 49 and each ranging from column (*SC*) 16 to column (*EC*) 61.

Enter	Format
HORZ	HORZ
1;40;16;61	<i>LT;R;SC;EC</i>
1;45;16;61	
1;49;16;61	
STOP	STOP

9. Add two vertical lines, each with a thickness (*LT*) of 1, both in column (*C*) 49, one ranging from row (*SR*) 40 to row (*ER*) 45 and the other ranging from row (*SR*) 49 to row (*ER*) 53.

Enter	Format
VERT	VERT
1;49;40;45	<i>LT;C;SR;ER</i>
1;49;49;53	
STOP	STOP

The last two commands have added to the form definition. PRACTICE now looks like Figure 51.

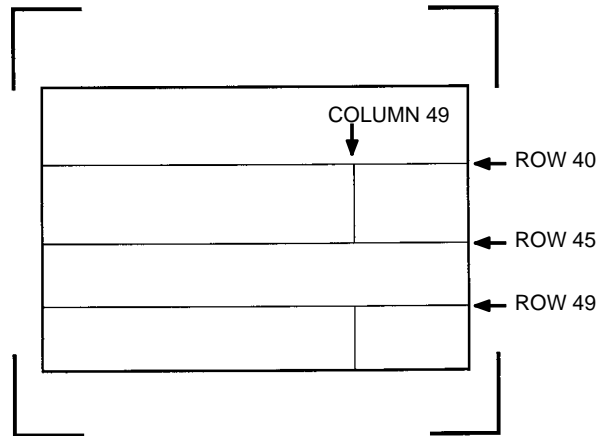

Figure 51. Box/Corner Example with Horizontal and Vertical Lines

Adding Fixed Alphanumeric Text

- Use the Create Form mode Alpha command to add some fixed alphanumeric text to the form. Specify some compressed print (*Cn*), the starting row (*SR*) and starting column (*SC*) for each alphanumeric string, any vertically (*VE*) or horizontally (*HE*) expanded strings, and the alphanumeric string itself which must be within the printable character (quotation marks or asterisks, for example). Substitute your own name, address, etc. in the appropriate areas. If you do not want to include some of the data on your form, do not enter the line.

Enter	Format
ALPHA	ALPHA
31;22;0;0;*ACME MOTOR, INC.*	[R;][E;][Cn;][AFn;L;][DIR;][UC;][DARK] SR;SC;VE;HE;(D)Text(D)
32;22;0;0;*17500 CARTWRIGHT ROAD*	
33;22;0;0;*IRVINE, CA 92714*	
35.9;17;0;0;*SERIAL NUMBER*	
40.3;17;0;0;*PART NUMBER*	
40.3;50;0;0;*MFG. DATE*	
45.3;17;0;0;*DESCRIPTION*	
49.3;17;0;0;*INTERFACE*	
49.3;50;0;0;*VERSION*	
C13;31;16;0;0;*FROM:*	
C15;54;26;0;0;*Call ACME MOTOR for more information.*	
C15;55;34;0;0;*1(714)863-1900*	
STOP	STOP

Note

The sample data entered above uses CP.DP format (such as 35.9, 40.3, etc.) in the starting row (SR) parameters. This precisely positions the data to avoid overlapping the alphanumeric data with the box and horizontal line data previously entered. For complete information on CP.DP format, refer to the “Commands” chapter.

At this point, the PRACTC.FRM file should contain the following form program data:

```

~CREATE;PRACTICE
BOX
2;35;16;53;61
STOP
CORNER
3;30;13;57;64;5;7
STOP
HORZ
1;40;16;61
1;45;16;61
1;49;16;61
STOP
VERT
1;49;40;45
1;49;49;53
STOP
ALPHA
31;22;0;0;*ACME MOTOR, INC*
32;22;0;0;*17500 CARTWRIGHT ROAD*
33;22;0;0;*IRVINE, CA 92714*
35.9;17;0;0;*SERIAL NUMBER*
40.3;17;0;0;*PART NUMBER*
40.3;50;0;0;*MFG. DATE*
45.3;17;0;0;*DESCRIPTION*
49.3;17;0;0;*INTERFACE*
49.3;50;0;0;*VERSION*
C13;31;16;0;0;*FROM:*
C15;54;26;0;0;*Call ACME MOTOR for more information.*
C15;55;34;0;0;*(714)863-1900*
STOP
END
~EXECUTE;PRACTICE

~NORMAL

```

Note

Remember, a blank line must *always* separate the EXECUTE and NORMAL commands.

Notice that the END, EXECUTE;PRACTICE and NORMAL statements are still in the file. These are always necessary to end the storage of the form in the IGP and cause it to print. Print the file PRACTC.FRM. The PRACTICE form should look like Figure 52, except for any alphanumeric data substitutions you made. Again, if error messages occur, refer to “Solving Program Errors” on page 248.

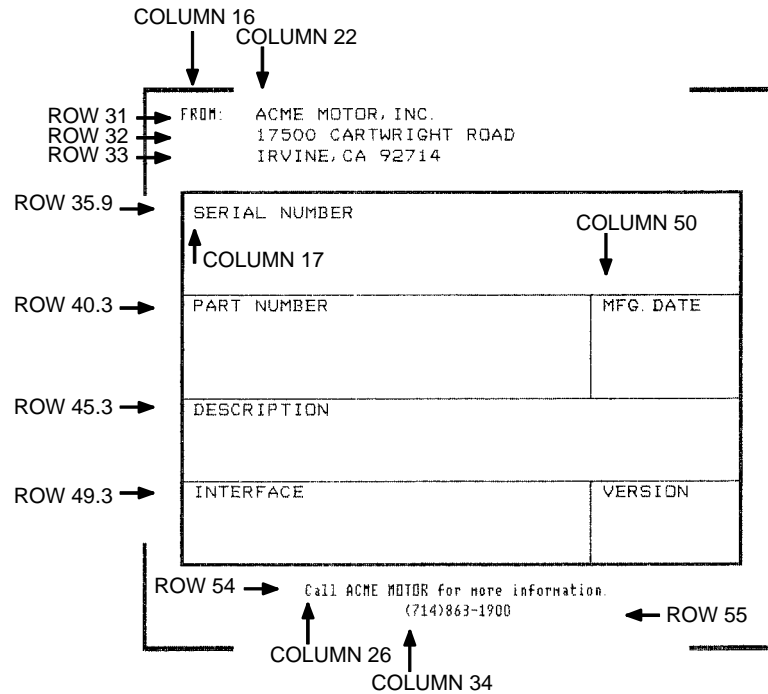

Figure 52. Practice Form Example

Adding a Bar Code

- Change the form definition by adding bar code type Code 39 (C3/9), one of the codes available on the IGP. First, reopen the file. Bar codes are defined in the Create Form mode; therefore, the Bar Code command must be entered before the End command line. In the Bar Code command, specify type C3/9 and 0.8 inch height (Hn). Use a dynamic bar code data field (BF) identified by the number (n) 1 with a length (L) of 5. The actual data will be provided dynamically in the Execute Form mode. Specify the starting row (SR) 35.7 and starting column (SC) 39, and stop the command.

Enter

```
BARCODE
C3/9;H8;BF1;5;DARK;35.7;39
STOP
```

Format

```
BARCODE
C3/9[CD];[VSCAN];[MAG];[Hn];[BFn;L];[DARK];SR;SC
[(D)data field(D)]
[PDF[;LOC];[;FONT]]
STOP
```

12. To dynamically input alphanumeric data fields, first identify the locations for the data in the Create Form mode as part of the form definition. Enter the locations in the existing Alpha command sequence (or use a new Alpha command). In the Alpha command sequence, enter the alphanumeric field (AF), the field number (*n*), length (*L*), starting row (*SR*) and column (*SC*), and any vertical (*VE*) or horizontal (*HE*) expansion. To enter this alphanumeric data in the existing Alpha command sequence, the data must be entered before the existing Alpha command STOP line.

Enter

```
AF1;7;38.7;19.3;3;3
AF2;11;43;20;2;2
AF3;31;47.3;20;2;1
AF4;33;51.3;20;2;1
```

Format

```
ALPHA (previously input)
[R;][E;][Cn;][AFn;L;][DIR;][UC;]SR;SC;VE;HE;(D)Text(D)
STOP (previously input)
```

13. Supply the dynamic data during the Execute Form mode (following the EXECUTE;PRACTICE line). Use the SFCC, specify the dynamic alphanumeric field (AF), bar code field (BF), the field number (corresponding to those just entered in the form definition), and the data itself. This method can be repeated to supply new data to each form printed by separating the pages of data with a form feed. Refer to "Execute Form: Dynamic Alphanumeric Data" on page 62.

Enter

```
~AF1;*49114*
~AF2;*106772-902*
~AF3;*INTELLIGENT GRAPHICS PROCESSOR*
~AF4;*PARALLEL - CENTRONICS*
~BF1;*49114*
```

Format

```
(cc)AFn;(D)data(D)
(cc)BFn;(D)data(D)
```

14. Now the PRACTC.FRM file contains all the following information (the complete form program). Print the form by printing the file. The completed form is shown in Figure 53.

```
~CREATE;PRACTICE
BOX
2;35;16;53;61
STOP
CORNER
3;30;13;57;64;5;7
STOP
HORZ
1;40;16;61
1;45;16;61
1;49;16;61
STOP
VERT
1;49;40;45
1;49;49;53
STOP
ALPHA
31;22;0;0;*ACME MOTOR, INC.*
32;22;0;0;*17500 CARTWRIGHT ROAD*
33;22;0;0;*IRVINE, CA 92714*
35.9;17;0;0;*SERIAL NUMBER*
```

```

40.3;17;0;0;*PART NUMBER*
40.3;50;0;0;*MFG. DATE*
45.3;17;0;0;*DESCRIPTION*
49.3;17;0;0;*INTERFACE*
49.3;50;0;0;*VERSION*
C13;31;16;0;0;*FROM:*
C15;54;26;0;0;*Call ACME MOTOR for more information.*
C15;55;34;0;0;*(714)863-1900*
AF1;7;38.7;19.3;3;3
AF2;11;43;20;2;2
AF3;31;47.3;20;2;1
AF4;33;51.3;20;2;1
STOP
BARCODE
C3;9;H8;BF1;5;DARK;35.7;39
STOP
END
~EXECUTE;PRACTICE
~AF1;*49114*
~AF2;*106772-902*
~AF3;*INTELLIGENT GRAPHICS PROCESSOR*
~AF4;*PARALLEL-CENTRONICS*
~BF1;*49114*

~NORMAL
    
```

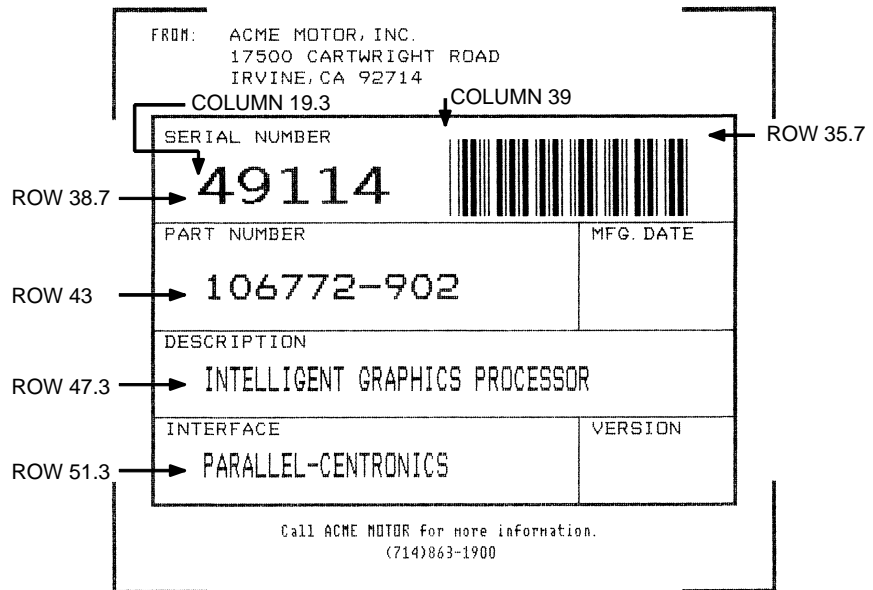

Figure 53. Completed Practice Form Example

Logo Exercise

In this exercise, you will generate a logo. The following sample uses a hand logo. Using dot scaling (discussed in detail on page 83) on an 8-1/2 x 11-inch form, a hand was drawn on a grid, with each dot tabulated by row and column position. If a grid coordinate occupies half or more of a dot position, include that position in your logo program. (Grid samples are located in Appendix B.)

Each dot position used must be identified individually. However, you can use a hyphen between the starting and ending columns to indicate a section of consecutive dots. For example, this hand logo requires dots in row 1, columns 40-42, shown in Figure 54. A sequential row order is not required.

A logo is created and stored as an element in the definition of a form. For example, to use a logo, first design it in the Create Logo mode; then add it to a form in the Create Form mode; then execute the form (with the logo) in the Execute Form mode. The following logo exercise includes all three of these steps.

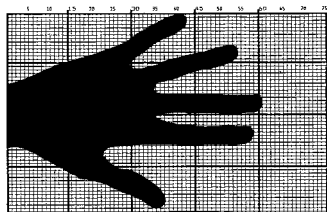

DOT POSITIONS

Row	Column
1	40-42
2	35-42
3	36-42
4	35-42
5	33-41
6	31-40
7	30-38
8	29-36
9	28-35
10	27-34;52-54
11	24-33;48-54
12	22-31;45-54
13	19-30;41-54
14	16-29;38-53
15	13-29;36-51
16	11-29;33-48
17	9-44
18	7-42
19	6-39
20	4-36
21	1-34
22	1-34
23	1-34
24	1-60
25	1-60
26	1-60
27	1-60
28	1-59
29	1-59
30	1-35

DOT POSITIONS

Row	Column
31	1-36
32	1-39
33	1-58
34	1-58
35	1-58
36	1-58
37	1-58
38	1-57
39	4-24
40	7-23
41	8-23
42	9-23
43	11-24
44	12-25
45	14-27
46	15-30
47	17-32
48	18-35
49	22-34
50	25-35
51	26-36
52	28-37
53	30-37
54	32-37
55	33-37
56	35-36

Figure 54. Sample Logo

Creating a Logo

1. Use your system commands to open a file for the logo program with the filename HNDLGO.FOM. For example:

Enter	Format
HNDLGO.FOM	(System Format)

2. Input the Special Function Control Character and Logo mode command to put the IGP in the Create Logo mode. Include HAND as the logo name; specify a vertical length (VL) of 56 (column length) and a horizontal length (HL) of 60 (row length).

Enter	Format
~LOGO;HAND;56;60	(cc)LOGO;logoname;VL;HL

3. Enter each row of dot positions as tabulated from the grid and shown in Figure 54. The format is Row;Column (for example, 15;13-29;36-51). Each row is entered on a separate line. After all the dot positions are entered, terminate the Create Logo mode by entering an End command line.

4. Use the Special Function Control Character and Create command to create a form with the form name LEFTHAND. To add the logo to the form, input a Create Form mode Logo Call command, identify the logo starting row (SR) 45 and starting column (SC) 33, and specify the logo to use by its name (HAND). Stop the Logo command and end the Create Form mode.

Enter	Format
~CREATE;LEFTHAND	(cc)CREATE;[/]formname[/;FL]
LOGO	LOGO
45;33;HAND	SR;SC;logoname
STOP	STOP
END	END

5. Input the Special Function Control Character and Execute command for the LEFTHAND form just created. Input a blank line, the Special Function Control Character, and the Normal command to instruct the IGP to return to the Normal mode after execution.

Enter	Format
~EXECUTE;LEFTHAND	(cc)EXECUTE;formname[/;PAGE n]
	[/;FC]
~NORMAL	(cc)NORMAL

6. Use system commands to exit the HNDLGO.FOM file and print. The finished program and logo should look like the following sample. If error messages occur, refer to "Solving Program Errors" on page 248.

```
~LOGO;HAND;56;60
1;40-42
2;38-42
3;36-42
4;35-42
5;33-41
6;31-40
7;30-38
8;29-36
9;28-35
```

```

10;27-34;52-54
11;24-33;48-54
12;22-31;45-54
13;19-30;41-54
14;16-29;38-53
15;13-29;36-51
16;11-29;33-48
17;9-44
18;7-42
19;6-39
20;4-36
21;1-34
22;1-34
23;1-34
24;1-60
25;1-60
26;1-60
27;1-60
28;1-59
29;1-59
30;1-35
31;1-36
32;1-39
33;1-58
34;1-58
35;1-58
36;1-58
37;1-58
38;1-57
39;4-24
40;7-23
41;8-23
42;9-23
43;11-24
44;12-25
45;14-27
46;15-30
47;17-32
48;18-33
49;22-34
50;25-35
51;26-36
52;28-37
53;30-37
54;32-37
55;33-37
56;35-36
END
~CREATE;LEFTHAND
LOGO
45;33;HAND
STOP
END
~EXECUTE;LEFTHAND

~NORMAL

```

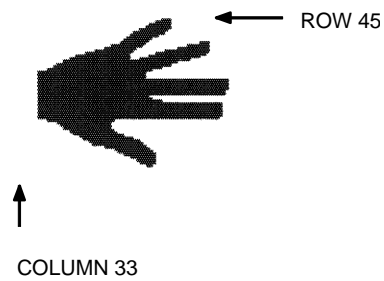

Form Design

In this exercise, you will produce a complete form by sketching it out on a grid in the same way the logo was designed. Again, this exercise uses character scaling on an 8-1/2 x 11-inch (60 x 72 dpi) page. Refer to page 83, where character scaling is discussed in detail.

Page Layout Considerations

At 6 lines per inch (lpi) and 10 characters per inch (cpi) printing, a standard 8-1/2 x 11-inch sheet of paper has a print area of 66 lines (rows) and 85 characters (columns). The printable area will vary if you are not printing at 6 lpi and 10 cpi. Thus, the grid used to design an 8-1/2 x 11-inch form should accommodate this 66 x 85 area.

Using the grids provided in Appendix B, sketch out the form layout and identify the starting and ending values. These values will be used to input IGP command parameters.

Planning the Form Layout

In this example, assume you work for the HandCraft Boat Company. Your slogan is "Quality boats crafted by hand," and the owner, Mr. Handcraft, has asked you to design a simple form that his salespeople can use for special orders. On the form, he wants a logo, the slogan, the customer's name, spaces for other particulars of the order, and a bar code to distinguish the sales region and boat division from other HandCraft enterprises. Begin this task as described below.

1. First design the form on the Standard Grid provided in Appendix B. Figure 55 shows the locations of the various form components. Compensate for expanded characters and plan for the logo.
2. Define the logo and then return to the form to add all the form components. Modify the hand logo already on file as the HandCraft logo. Use the Logo Grid in Appendix B, and refer to Figure 56 on page 242, which shows the dot positions of the hand logo with a boat added to the hand. When dot positions (or a range of dot positions) are *not* specified, the boat image in the hand emerges.
3. Open a file named HNDCFT.FOM to contain all the form information. As shown in the following example, use the Create Logo mode command, name the logo HANDCRFT, specify the logo height (*VL*) and width (*HL*), enter the dot positions used, and end the Logo command.

Enter	Format
HNDCFT.FOM	(System Format)
~LOGO;HANDCRFT;56;60	(cc)LOGO;logoname;VL;HL
1;40-42	row#;dot;dot1-dot2;dot
2;38-42	
3;36-42	
4;35-42	
5;33-41	
6;31-40	

7;30-38
8;29-36
9;28-35
10;27-34;52-54
11;24-33;48-54
12;22-31;45-54
13;19-30;41-54
14;16-29;38-53
15;13-17;19-29;36-51
16;11-17;20-29;33-48
17;9-17;21-44
18;7-17;22-42
19;6-17;22-39
20;4-17;23-36
21;1-17;24-34
22;1-17;25-34
23;1-17;26-34
24;1-17;27-60
25;1-17;28-60
26;1-17;29-60
27;1-17;30-60
28;1-17;31-59
29;1-17;19-59
30;1-17;19-35
31;1-4;33-36
32;1-5;33-39
33;1-6;33-58
34;1-7;33-58
35;1-58
36;1-58
37;1-58
38;1-57
39;4-24
40;7-23
41;8-23
42;9-23
43;11-24
44;12-25
45;14-27
46;15-30
47;17-32
48;18-33
49;22-34
50;25-35
51;26-36
52;28-37
53;30-37
54;32-37
55;33-37
56;35-36
END

END

HandCraft Boats

CUSTOMER: _____ PHONE: _____
 ROLL NO: _____ RIGGING: _____
 COLOR: _____ DELIVERY DATE: _____

SPECIAL ORDER ITEMS

ITEM	DESCRIPTION	PRICE

HANDCRAFT BOATS
 123 MAIN ST
 WASHINGTON, DC
 20001
 (784) 555-0123

HANDCRAFT BOATS CRAFTED BY HAND
 ESTABLISHED 1988

Figure 55. Sample Form Design

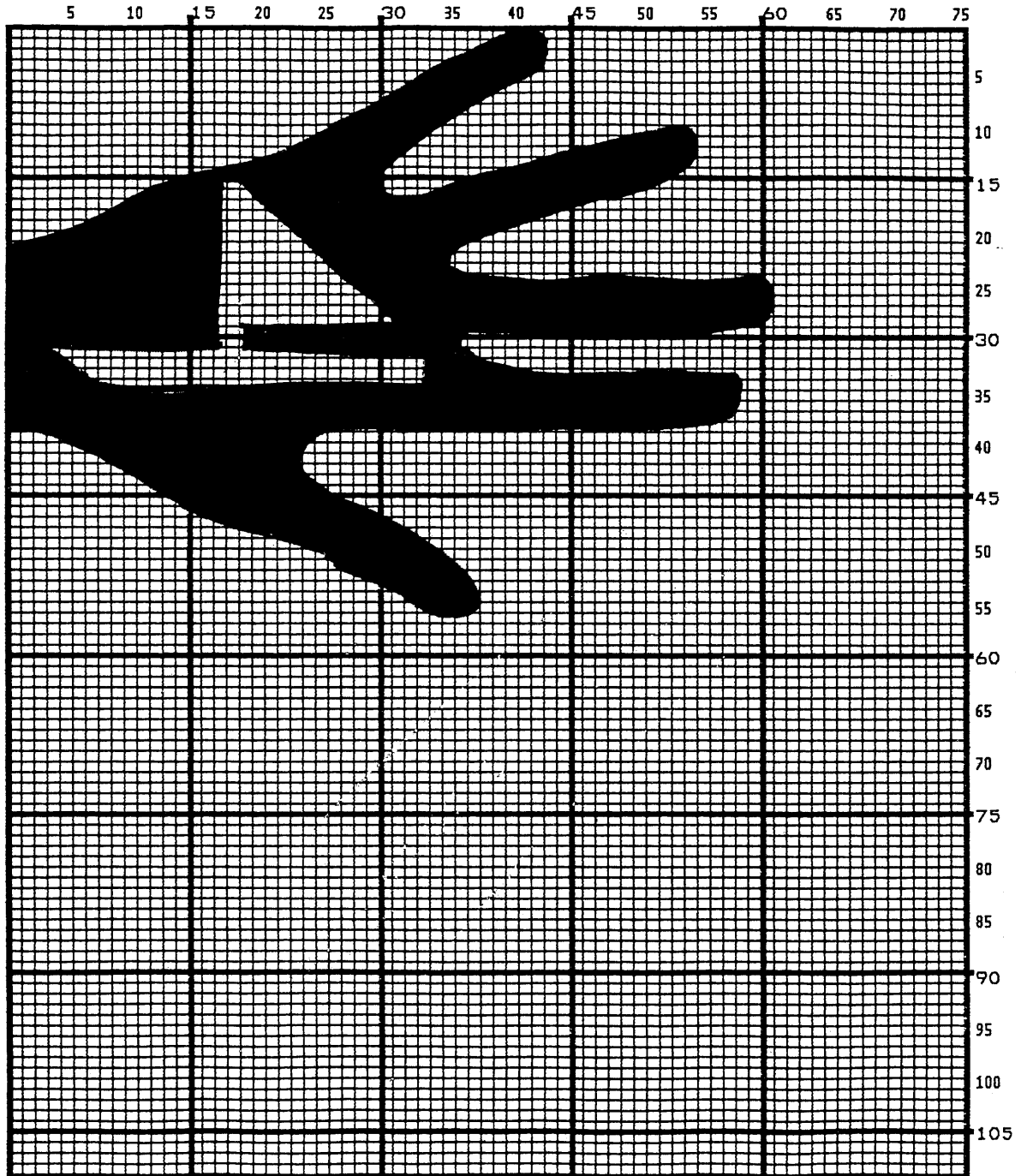

Figure 56. Logo Design

Creating a Form and Adding Form Components

4. Create the form and start adding the form components from the layout grid. (Refer to Figure 55 on page 241.) Use the Special Function Control Character and Create command to define a form named HCBOATS. Use the Box command to define the outer border with a line thickness (*LT*) 3, top left corner at row (*SR*) 11 column (*SC*) 10, and bottom right corner at row (*ER*) 55, column (*EC*) 70. In the same Box command sequence, define another box with a line thickness of 2, top left corner at row 28 column 14, and bottom right corner at row 44.9 column 66. After defining the boxes, stop the Box command.

Enter	Format
~CREATE;HCBOATS	(cc)CREATE;[/]formname[/;FL]
BOX	BOX
3;11;10;55;70	LT;SR;SC;ER;EC
2;28;14;44.9;66	
STOP	STOP

5. Mr. Handcraft would like corners around the slogan. Use the Corner command to define a line thickness (*LT*) of 2, top left corner at row (*SR*) 48 column (*SC*) 24, and bottom right corner at row (*ER*) 52 column (*EC*) 56. Make the vertical (*VL*) corner piece 4 spaces long and the horizontal (*HL*) corner piece 5 spaces long. Then stop the Corner command.

Enter	Format
CORNER	CORNER
2;48;24;52;56;4;5	LT;SR;SC;ER;EC;VL;HL
STOP	STOP

6. To make the columns for the special order items, add two vertical lines each with a line thickness (*LT*) of 1, one line in column (*C*) 22 and the other line in column 58. Each line will start at row (*SR*) 28 and end at row (*ER*) 44.9.

Enter	Format
VERT	VERT
1;22;28;44.9	LT;C;SR;ER
1;58;28;44.9	
STOP	STOP

7. To add the horizontal lines, define one line and then duplicate that line using the Vertical Duplication command. The line will have a single line thickness (*LT*), be in row (*R*) 30.4, starting in column (*SC*) 14 and ending in column (*EC*) 66. With vertical duplication, the line will be duplicated (*dup #*) 6 times with 2.5 row offset (*offset #*) spacing between each duplication. The Vertical Duplication command must be input, the horizontal line being duplicated must be input, and the Vertical Duplication command must be turned off.

Enter	Format
VDUP;6;2.5	VDUP;dup#;offset#
HORZ	HORZ
1;30.4;14;66	LT;R;SC;EC
STOP	STOP
VDUP;OFF	VDUP;OFF

8. All the text shown on the grid is fixed into position on the form with a single Alpha command sequence. The starting row, starting column, and text can be taken right from the grid and put into the program.

Enter

ALPHA

14;31;3;2;*HandCraft Boats*

18;14;0;0;*CUSTOMER:*

18;51;0;0;*PHONE:*

20;14;0;0;*HULL NO:*

20;49;0;0;*RIGGING:*

22;14;0;0;*COLOR:*

22;43;0;0;*DELIVERY DATE:*

25;31;1;1;*SPECIAL ORDER ITEMS*

27;17;0;0;*ITEM*

27;34;0;0;*DESCRIPTION*

27;60;0;0;*PRICE*

50;26;1;1;*Quality Boats Crafted By Hand*

C17;48;14;0;0;*HandCraft Boats*

C17;48.10;14;0;0;*123 Boat Way*

C17;49.8;14;0;0;*Boat Town, CA*

C17;50.6;19;0;0;*333444*

C17;51.4;14;0;0;*(714)555-0011*

STOP

Format

ALPHA

[R;][E;][Cn;][AFn;L;][DIR;][UC;][DARK;]SR;SC;VE;HE;(D)text(D)

STOP

9. HandCraft Boats uses bar code type Code 128B (C128B) in many applications. Use bar code C128B, height (Hn) of .5-inch, starting at row (SR) 49, column (SC) 59, code the West Coast Sales Region as *WC*, and print the data field (PDF) below the symbol.

Enter

BARCODE

C128B;H5;49;59

WC

PDF

STOP

Format

BARCODE

C128B;[VSCAN;][MAG;][Hn;][BFn;L;]

[DARK;]SR;SC

[(D)datafield(D)]

[PDF[;LOC];FONT]

STOP

Note

The decimal point is not entered in the height parameter (H5) above because values are expected in .10-inch increments. Values from 4 through 99 (.4-inch to 9.9 inches) are accepted.

10. Add the logo and end the Create Form mode. Use the Logo Call command, specify the starting row (*SR*) at 12 and column (*SC*) at 18 as shown on the grid and call the logo by name (HANDCRFT). The starting row and column of the logo refer to the upper left corner of the grid used in the logo design.

Enter	Format
LOGO	LOGO
12;18;HANDCRFT	<i>SR;SC;logoname</i>
STOP	STOP
END	END

11. Execute the form (HCBOATS), return to the Normal mode (remember the blank line before the NORMAL command), exit the file using your system commands (if necessary), and print the document.

Enter	Format
~EXECUTE;HCBOATS	(cc)EXECUTE; <i>formname</i> [:PAGE <i>n</i>][:FC]
~NORMAL	(cc)NORMAL
.PRINT HNDCT.FOM	(System Format)

Note  Always separate the EXECUTE and NORMAL commands by a blank line.

Figure 57 shows the finished form. If Mr. Handcraft would like to rearrange the words, change line thickness of a box, etc., simply open the file and change the appropriate command lines. Otherwise, his salespeople have a new form for notes on custom orders.



HandCraft Boats

CUSTOMER

PHONE:

HULL NO:

RIGGING:

COLOR:

DELIVERY DATE:

SPECIAL ORDER ITEMS

ITEM	DESCRIPTION	PRICE

HandCraft Boats
 123 Boat Way
 Boat Town, CA
 333444
 (714) 555-0011

Quality Boats Crafted By Hand



Figure 57. Completed Sample Form

Directory Command

The Directory command lists the contents of the IGP directory in IGP memory. The directory command provides the following information:

- All form names and logo names currently defined
- The association of logos to forms
- The amount of memory used for form storage
- The amount of dynamic storage space used and available

Example

A form will not execute unless enough room exists in the memory as indicated in the work space bytes free portion of the directory listing. To print the directory, open a file, input the directory command, exit the file, and print. For example:

Enter	Format
DIRECT.FOM	(System Format)
~DIRECTORY	(cc)DIRECTORY
.PRINT DIRECT.FOM	(System Format)

The Directory command can only be used when the IGP is in the Normal mode. Upon completion of the directory listing, the IGP returns to the Normal mode. If the IGP is not in the Normal mode, input the Normal mode command before the Directory command.

Form Directory

Form Name	Form Size	Logos
PRACTICE. frm	2172	
HCBOATS. frm	2560	HANDCRFT. lgo
LEFTHAND. frm	380	HANDCRFT. lgo
TEST. frm	380	
UPCA. frm	908	
POSTNET. frm	859	
MSI. frm	686	
I25. frm	648	
C128C. frm	654	
EAN8. frm	788	
C128B. frm	732	
C39. frm	728	
BOX. frm	380	
AIAG. frm	5260	

Logos on File / Memory Used

HANDCRFT. lgo	856
---------------	-----

Forms Memory Used.....	17135	bytes
Logo Memory Used.....	856	bytes
Total Memory Used.....	17991	bytes
Dynamic Memory Available.....	834336	bytes

Delete Command

The Delete command deletes any individual form or logo from the IGP memory according to your specifications. The deletion of a form includes its directory entry and any alphanumeric or vector information associated with it. The Delete command is used only when the IGP is in the Normal mode.

Deletion of a logo includes its directory entry and its data in the logo storage area. Deletion of a valid logo which is still combined with a form will not cause an error at the time it is deleted; however, an error will occur if you execute a form that contains a previously deleted logo.

Example

From the directory printed in the preceding section, delete the practice form, the HandCraft Logo, and the HandCraft Boats form. Similar to the format used with other command sequences, the procedure is as follows: open a file, input the commands, exit the file, and print. For example:

Enter	Format
DELETE.FRM	(System Format)
~DELETE FORM;PRACTICE	(cc)DELETE FORM; <i>formname</i>
~DELETE FORM;HCBOATS	
~DELETE LOGO;HANDCRFT	(cc)DELETE LOGO; <i>logoname</i>
.PRINT DELETE.FRM	(System Format)

Note



List the directory again to verify that the forms and logos were deleted.

A form cannot execute if insufficient space exists in the IGP memory. The directory Dynamic Work Space Bytes Free must be greater than the total size (in bytes) of the form. Delete older forms and/or logos to allow memory space for new forms and logos, or include the Delete command as the last statement in a logo or form program to immediately delete the data after it is processed. Creating a form (or logo) with the same name as an existing IGP form (or logo) will automatically delete the existing form (or logo).

Solving Program Errors

If you make an error in the program to create a form or an element in the form, a coded error message and program line containing the error will print when the form is executed. These error codes are defined in the “Error Codes” chapter.

To solve program errors, perform the following steps:

1. Locate the error message in the listing provided in the “Error Codes” chapter for a description of the error.
2. Analyze the related portion of the program to find the error.
3. Correct the error and reprint the file containing the program.

4. If the error persists or you cannot locate it in the program, use the debug parameter [/] in the Create command as described in the "Error Codes" chapter. Print the file with the IGP program. The debug parameter lists the program, line by line (including the error on the line where the error occurs), followed by the error-free sections of the form. Correct the error and print the file again. When the error has been corrected, delete the debug parameter.

Example

Assume you made two errors in the Box and Corner commands input in steps 3 and 4 of the Form and Bar Code Example on page 229. Using the debug parameter in the Create command produces the following sample listing:

```
(SFCC) CREATE; /PRACTICE
BOX
2;35;16:53;61
*** ERROR 24 : BOX format or delimiter error in input parameters
STOP
CORNER
3;300;13;57;64;5;7
*** ERROR 35 : CORNER vertical length VL out of bounds
*** ERROR 31 : CORNER starting row SR out of bounds
*** ERROR 39 : CORNER starting row SR > ending row ER
STOP
END
```

From the description of the error messages and the incorrect line identified by the error message, the errors are easily located and corrected. Notice a colon was accidentally input in the Box command where a semicolon was required (error number 24).

```
/PRACTICE
BOX
2;35;16:53;61
*** ERROR 24 : BOX format or delimiter error in input parameters
STOP
```

In the Corner command, the starting row was too large. This single input error caused the vertical length of the corner to extend beyond the form boundaries (error number 35), the starting row to begin outside the form boundaries (error number 31), and the starting/ending row parameters to be out of order (error number 39).

```
CORNER
3;300;13;57;64;5;7
*** ERROR 35 : CORNER vertical length VL out of bounds
*** ERROR 31 : CORNER starting row SR out of bounds
*** ERROR 39 : CORNER starting row SR > ending row ER
STOP
END
```

5

Multinational Character Sets

Introduction

The Multinational Character Set accesses one of many international character sets. Each character set is 96 characters long and can be accessed by configuration selection or IGP command. Individual characters in the font can be accessed with the use of data bit 8.

Supported Character Sets

The Multinational Character Set provides the IGP/PGL with space for 32 character sets, 96 characters each. The character sets and their corresponding set values are listed in Table 21.

Table 21. Multinational Character Sets and Set Values

Character Set	Value	Character Set	Value
US ASCII	0	Dutch	7
German	1	French	8
Swedish	2	Spanish	9
Danish	3	Italian	10
Norwegian	4	Turkish	11
Finnish	5	Reserved	12-23
English	6	User-Defined Sets	24-31

Standard PGL sets 0 through 11 are resident character sets. Sets 12 through 23 are reserved spaces in font memory for future resident character sets. If a value from 12 through 23 is called when attempting to choose a character set, the character font will default to ASCII. Character set values 24 through 31 are reserved for user-defined sets. You can create custom character sets from existing characters in font memory. If you select a set value from 24 to 31 when no new character set has been created or assigned that value, the character font will default to ASCII.

Refer to page 257 for printouts of the primary and extended character sets and their corresponding values.

Character Addresses

Both the ASCII and multinational character sets have hex values for each character and symbol. The primary character set (ASCII characters) resides at hex addresses ranging from 00 to 7F. The extended character set, which contains the multinational characters, resides at hex addresses ranging from 80 to FF. Table 22 shows each multinational character substitution hex value and the applicable ASCII hex values. To access the extended character set, the IGP must be configured with the data bit 8 option enabled.

Making Character Substitutions

Multinational character sets are created by substituting the multinational character values for the standard ASCII values. Each of the 12 multinational character sets allows up to 16 character substitutions (located at 21, 22, 23, 24, 25, 26, 40, 5B, 5C, 5D, 5E, 60, 7B, 7C, 7D, and 7E hex). The most common character substitutions specific to a particular country are provided in each set and shown in Table 22.

For example, when the Danish character set is selected, calling character address cell 5B (Æ) substitutes the Danish character residing at C6 from the Multinational Character Set. When the Spanish character set is selected, calling character address cell 7C(ñ) substitutes the Spanish character residing at F1 from the Multinational Character Set. These substitutions are automatically performed when a particular Multinational Character Set is selected./

Table 22. Substitution Set Hex Values

Character Set	Substitution Hex Value															
	21	22	23	24	25	26	40	5B	5C	5D	5E	60	7B	7C	7D	7E
U.S. ASCII																
Danish								C6	D8	C5		B0	E6	F8	E5	
Dutch			A3						80					81		
English			A3													
Finnish				A4				C4	D6	C5			E4	F6	E5	FC
French							E0	FB	E7	A7	F4	EA	E9	F9	E8	EE
German							A7	C4	D6	DC			E4	F6	FC	DF
Italian							A7	B0	E9	83		F9	E0	F2	E8	EC
Norwegian				A4			C9	C6	D8	C5	DC	E9	E6	F8	E5	FC
Spanish			82					C3	D1	D5	A1		E3	F1	F5	BF
Swedish				A4			C9	C4	D6	C5	DC	E9	E4	F6	E5	FC
Turkish	84	C7	E7	85				86	D6	DC	87	88	89	F6	FC	8A

Accessing Characters and Character Sets

OCR Character Sets

Purpose Accesses OCR-A and OCR-B character sets.

Mode CREATE, NORMAL and EXECUTE

Format See Comments

Comments In the Create mode, you can access OCR fonts using the alphanumeric command. Use the *Cn* parameter in the ALPHA command. See page 29 for more information. In the Normal and Execute modes, you can access OCR fonts using the Compressed Print (Density) command (page 45).

Note OCR fonts are only available in 10 cpi.



Data Bit 8

You can access individual characters using data bit 8 addressing. The primary character set is ASCII. These character values reside at hex addresses 20 through 7F. The multinational or extended character sets reside at hex addresses 80 through FF and are accessible without reconfiguration.

Note Data bit 8 must be set high so that multinational or extended character sets are accessible without reconfiguration. However, the PION/PIOFF command (page 79) must *also* be set OFF to access these character sets in the 80-FF hex range. A PION setting will cause data in the 80-FF hex range to be interpreted as PI line data instead of extended character set data.



Power-Up Character Set Selection

You can select any one of the twelve resident multinational character sets shown in Table 21 (0 through 11) as the default character set at printer power-up. The IGP configuration settings determine which character set is the default character set at power-up.

The character font selected at power-up will remain active until the ISET command is selected or the configuration is changed. OCR and user-definable character sets cannot be configured as the default character set at printer power-up.

User-Defined Set Command (USET)

Purpose	Creates custom character sets (except OCR fonts) from existing characters stored in memory.
Mode	NORMAL
Format	(cc)USET <i>n</i> <i>ca;fa</i> END
(cc)	Represents the Special Function Control Character.
USET	The User Set command; enter USET .
<i>n</i>	Selects USET character set number; enter a value ranging from 1 through 8 .
<i>ca</i>	Represents the ASCII character cell hex address which will have its contents replaced with the character located in the font address (<i>fa</i>). The <i>ca</i> value must be one of the 16 hex values specified in Table 23 on page 255.
<i>fa</i>	Represents the hexadecimal value for the font address of a specified character in the Multinational character set which will replace the current contents of <i>ca</i> . The <i>fa</i> value is the character substitution for the cell address (<i>ca</i>). The value of <i>fa</i> may range from 20 through FF hex.
END	Ends the USET command.

Comments You can define up to 16 character substitutions for *each* of the eight user-definable character sets. It is not necessary to address all 16 spaces available for character substitutions with a single USET command.

The character sets in the USET command are numbered 1 through 8. The character set values in the Character Set Selection (ISET) command (page 256) are numbered 24 through 31 and correspond to User Sets 1 through 8. The ISET command accesses and prints that custom character set.

The USET and ISET commands are related as shown in Table 23. Therefore, ISET;24 selects the substitution set defined as USET1, ISET;29 selects USET6, etc.

Table 23. USET-ISET Relationship

USET; <i>n</i>	<i>corresponds to</i>	ISET; <i>n</i>
n = 1		n = 24
n = 2		n = 25
n = 3		n = 26
n = 4		n = 27
n = 5		n = 28
n = 6		n = 29
n = 7		n = 30
n = 8		n = 31

Example The following example defines User Set 1 to contain the Multinational font addresses B1 (\pm), A1 ($\grave{\imath}$), and BF ($\grave{\zeta}$) at the hex cell addresses 23, 24, and 25, respectively. Therefore, if $ca = 23$ and $fa = B1$, each time that cell address 23 is received, it will select the character located at font address B1 (\pm).

```

~USET1
23;B1
24;A1
25;BF
END

```

User Set 1 now contains the following: the plus or minus sign \pm (B1 hex) in place of the number sign # (23 hex); the upside down exclamation point $\grave{\imath}$ (A1 hex) in place of the dollar sign \$ (24 hex); and the upside down question mark $\grave{\zeta}$ (BF hex) in place of the percent sign % (25 hex). To print User Set 1, you must use the ISET command discussed on page 256.

Character Set Selection Command (ISET)

Purpose Accesses one of the 32 multinational character sets from Table 21. Use this command to access a different character set from the configured power-up default character set.

Mode NORMAL, CREATE, and EXECUTE

Format In Normal and Execute modes: (cc)ISET; *n*
In the Create mode (SFCC not required): ISET; *n*

(cc) Represents the Special Function Control Character.

ISET The Multinational Character Set command; enter **ISET**.

n The character substitution set number; enter a value from Table 21.

For example, refer to Table 23. If you want to use the User Set 1 created in the example on page 255, call ISET;24. Similarly, if you want User Set 5 that you had previously defined, call ISET;28 to select and print the User Set 5 substitution set.

Comments You can issue the ISET command as many times within a form as needed. The character set selected will remain active until a new character set is selected. If you choose an incorrect character set value or make a syntax error, an error message will result. If a value for *n* is not specified, an error message will print.

Using the ISET command in the Execute mode declares the character set for use in conjunction with the dynamic data within that Execute command. Fixed form data specified in the Create mode is not affected by an ISET command in the Execute mode. The character set selected will remain in effect until another character set is selected.

Multinational Character Sets

IGP/PGL MULTINATIONAL Set																
	0	1	2	3	4	5	6	7	8	9	A	B	C	D	E	F
0			0	@	P	'	p	IJ			°	À	Ð	à	ð	
1	!	1	A	Q	a	q	ij				±	Ã	Ñ	â	ñ	
2	"	2	B	R	b	r	pt				²	Ä	Ò	ã	õ	
3	#	3	C	S	c	s		Π			³	Å	Ó	ä	ö	
4	\$	4	D	T	d	t	Π				¼	Ä	Ö	å	ø	
5	%	5	E	U	e	u	Γ				½	Å	Ö	ä	ö	
6	&	6	F	V	f	v	Γ				¾	Æ	Ø	æ	ø	
7	'	7	G	W	g	w	Γ				°	Ç	×	ç	÷	
8	(8	H	X	h	x	Γ				°	È	Ø	è	ø	
9)	9	I	Y	i	y	Γ				°	É	Ù	é	ù	
A	*	:	J	Z	j	z	Γ				°	Ê	Û	ê	û	
B	+	:	K	[k	{	Γ				°	Ë	Ü	ë	ü	
C	.	<	L	\	l	~	Γ				°	Ë	Ü	ë	ü	
D	-	=	M]	m	}	Γ				°	Ë	Ü	ë	ü	
E	.	>	N	^	n	~	Γ				°	Ë	Ü	ë	ü	
F	/	?	O	_	o	~	Γ				°	Ë	Ü	ë	ü	

ASCII Set								
	0	1	2	3	4	5	6	7
0			0	@	P	'	p	
1	!	1	A	Q	a	q		
2	"	2	B	R	b	r		
3	#	3	C	S	c	s		
4	\$	4	D	T	d	t		
5	%	5	E	U	e	u		
6	&	6	F	V	f	v		
7	'	7	G	W	g	w		
8	(8	H	X	h	x		
9)	9	I	Y	i	y		
A	*	:	J	Z	j	z		
B	+	:	K	[k	{		
C	.	<	L	\	l	~		
D	-	=	M]	m	}		
E	.	>	N	^	n	~		
F	/	?	O	_	o	~		

GERMAN Set								
	0	1	2	3	4	5	6	7
0			0	\$	P	'	p	
1	!	1	A	Q	a	q		
2	"	2	B	R	b	r		
3	#	3	C	S	c	s		
4	\$	4	D	T	d	t		
5	%	5	E	U	e	u		
6	&	6	F	V	f	v		
7	'	7	G	W	g	w		
8	(8	H	X	h	x		
9)	9	I	Y	i	y		
A	*	:	J	Z	j	z		
B	+	:	K	Ä	k	ä		
C	.	<	L	Ö	l	ö		
D	-	=	M	Ü	m	ü		
E	.	>	N	^	n	~		
F	/	?	O	_	o	~		

SWEDISH Set

	0	1	2	3	4	5	6	7
0			0	É	P	é	p	
1	!	1	A	Q	a	q		
2	"	2	B	R	b	r		
3	#	3	C	S	c	s		
4	¤	4	D	T	d	t		
5	%	5	E	U	e	u		
6	&	6	F	V	f	v		
7	'	7	G	W	g	w		
8	(8	H	X	h	x		
9)	9	I	Y	i	y		
A	*	:	J	Z	j	z		
B	+	;	K	Ä	k	ä		
C	,	<	L	Ö	l	ö		
D	-	=	M	Å	m	å		
E	.	>	N	Ü	n	ü		
F	/	?	O	_	o			

DANISH Set

	0	1	2	3	4	5	6	7
0			0	@	P	°	p	
1	!	1	A	Q	a	q		
2	"	2	B	R	b	r		
3	#	3	C	S	c	s		
4	\$	4	D	T	d	t		
5	%	5	E	U	e	u		
6	&	6	F	V	f	v		
7	'	7	G	W	g	w		
8	(8	H	X	h	x		
9)	9	I	Y	i	y		
A	*	:	J	Z	j	z		
B	+	;	K	Æ	k	æ		
C	,	<	L	Ø	l	ø		
D	-	=	M	Å	m	å		
E	.	>	N	^	n	~		
F	/	?	O	_	o			

NORWEGIAN Set

	0	1	2	3	4	5	6	7
0			0	É	P	é	p	
1	!	1	A	Q	a	q		
2	"	2	B	R	b	r		
3	#	3	C	S	c	s		
4	¤	4	D	T	d	t		
5	%	5	E	U	e	u		
6	&	6	F	V	f	v		
7	'	7	G	W	g	w		
8	(8	H	X	h	x		
9)	9	I	Y	i	y		
A	*	:	J	Z	j	z		
B	+	;	K	Æ	k	æ		
C	,	<	L	Ø	l	ø		
D	-	=	M	Å	m	å		
E	.	>	N	Ü	n	ü		
F	/	?	O	_	o			

FINNISH Set

	0	1	2	3	4	5	6	7
0			0	@	P	'	p	
1	!	1	A	Q	a	q		
2	"	2	B	R	b	r		
3	#	3	C	S	c	s		
4	¤	4	D	T	d	t		
5	%	5	E	U	e	u		
6	&	6	F	V	f	v		
7	'	7	G	W	g	w		
8	(8	H	X	h	x		
9)	9	I	Y	i	y		
A	*	:	J	Z	j	z		
B	+	;	K	Ä	k	ä		
C	,	<	L	Ö	l	ö		
D	-	=	M	Å	m	å		
E	.	>	N	^	n	ü		
F	/	?	O	_	o			

ENGLISH Set

	0	1	2	3	4	5	6	7
0			0	@	P	'	p	
1		!	1	A	Q	a	q	
2		"	2	B	R	b	r	
3		£	3	C	S	c	s	
4		\$	4	D	T	d	t	
5		%	5	E	U	e	u	
6		&	6	F	V	f	v	
7		'	7	G	W	g	w	
8		(8	H	X	h	x	
9)	9	I	Y	i	y	
A	*	:	J	Z	j	z		
B	+	;	K	[k	{		
C	,	<	L	\	l			
D	-	=	M]	m	}		
E	.	>	N	^	n	~		
F	/	?	O	_	o			

DUTCH Set

	0	1	2	3	4	5	6	7
0			0	@	P	'	p	
1		!	1	A	Q	a	q	
2		"	2	B	R	b	r	
3		£	3	C	S	c	s	
4		\$	4	D	T	d	t	
5		%	5	E	U	e	u	
6		&	6	F	V	f	v	
7		'	7	G	W	g	w	
8		(8	H	X	h	x	
9)	9	I	Y	i	y	
A	*	:	J	Z	j	z		
B	+	;	K	[k	{		
C	,	<	L	IJ	l	ij		
D	-	=	M]	m	}		
E	.	>	N	^	n	~		
F	/	?	O	_	o			

FRENCH Set

	0	1	2	3	4	5	6	7
0			0	à	P	ê	p	
1		!	1	A	Q	a	q	
2		"	2	B	R	b	r	
3		#	3	C	S	c	s	
4		\$	4	D	T	d	t	
5		%	5	E	U	e	u	
6		&	6	F	V	f	v	
7		'	7	G	W	g	w	
8		(8	H	X	h	x	
9)	9	I	Y	i	y	
A	*	:	J	Z	j	z		
B	+	;	K	û	k	é		
C	,	<	L	ç	l	ù		
D	-	=	M	\$	m	è		
E	.	>	N	ô	n	î		
F	/	?	O	_	o			

SPANISH Set

	0	1	2	3	4	5	6	7
0			0	@	P	'	p	
1		!	1	A	Q	a	q	
2		"	2	B	R	b	r	
3		¢	3	C	S	c	s	
4		\$	4	D	T	d	t	
5		%	5	E	U	e	u	
6		&	6	F	V	f	v	
7		'	7	G	W	g	w	
8		(8	H	X	h	x	
9)	9	I	Y	i	y	
A	*	:	J	Z	j	z		
B	+	;	K	Ã	k	ã		
C	,	<	L	Ñ	l	ñ		
D	-	=	M	Õ	m	õ		
E	.	>	N	i	n	¿		
F	/	?	O	_	o			

ITALIAN Set

	0	1	2	3	4	5	6	7
0			0	\$	P	ù	p	
1		!	1	A	Q	a	q	
2		"	2	B	R	b	r	
3		#	3	C	S	c	s	
4		\$	4	D	T	d	t	
5		%	5	E	U	e	u	
6		&	6	F	V	f	v	
7		'	7	G	W	g	w	
8	(8	H	X	h	x	
9)		9	I	Y	i	y	
A	*	:	J	Z	j	z		
B	+	;	K	°	k	à		
C	,	<	L	é	l	ò		
D	-	=	M		m	è		
E	.	>	N	^	n	ì		
F	/	?	O	_	o			

TURKISH Set

	0	1	2	3	4	5	6	7
0			0	@	P	Ş	p	
1		ı	1	A	Q	a	q	
2		Ç	2	B	R	b	r	
3		ç	3	C	S	c	s	
4		ı	4	D	T	d	t	
5		%	5	E	U	e	u	
6		&	6	F	V	f	v	
7		'	7	G	W	g	w	
8	(8	H	X	h	x	
9)		9	I	Y	i	y	
A	*	:	J	Z	j	z		
B	+	;	K	Ğ	k	ş		
C	,	<	L	Ö	l	ö		
D	-	=	M	Ü	m	ü		
E	.	>	N	ğ	n	ı		
F	/	?	O	_	o			

OCR-A Set

	0	1	2	3	4	5	6	7
0			0	@	P	H	p	
1		!	1	A	Q	a	q	
2		"	2	B	R	b	r	
3		#	3	C	S	c	s	
4		\$	4	D	T	d	t	
5		%	5	E	U	e	u	
6		&	6	F	V	f	v	
7		'	7	G	W	g	w	
8	(8	H	X	h	x	
9)		9	I	Y	i	y	
A	*	:	J	Z	j	z		
B	+	;	K	€	k	{		
C	,	<	L	\	l			
D	-	=	M]	m	}		
E	.	>	N	^	n	~		
F	/	?	O	¥	o	.		

OCR-B Set

	0	1	2	3	4	5	6	7
0			0	@	P	'	p	
1		!	1	A	Q	a	q	
2		"	2	B	R	b	r	
3		#	3	C	S	c	s	
4		\$	4	D	T	d	t	
5		%	5	E	U	e	u	
6		&	6	F	V	f	v	
7		'	7	G	W	g	w	
8	(8	H	X	h	x	
9)		9	I	Y	i	y	
A	*	:	J	Z	j	z		
B	+	;	K	[k	{		
C	,	<	L	\	l			
D	-	=	M]	m	}		
E	.	>	N	^	n	~		
F	/	?	O	_	o			

6

Error Codes

IGP/PGL Emulation Error Codes

The IGP provides coded error messages to assist in “debugging” programs. The printer will print an error message number and the program line which contains the error when an error is detected. To help determine exactly where the error occurred, use the following debug command sequence:

(CC)CREATE; /FORM NAME

The slash (/) places the IGP in a debug mode, and the program prints, line by line, with the error number and message printed below the specific error in the program. The error-free portions of the form will print following the program. After correcting the error(s), print the file again. When the errors have been corrected, delete the slash. A sample debug listing is shown in “Solving Program Errors” on page 248.

In the Execute mode, that part of the form which was correctly defined and stored during the Create mode will print, including any dynamic data and overlay text which was accepted before the error occurred. Sections containing errors must be corrected before storage in the Directory can take place. Any error messages will print following the printed form, and processing will continue in the Normal mode.

In the Create Form or Create Logo mode, any error messages will print first, followed by that part of the form/logo which was correctly defined. Incorrectly defined elements are excluded from the form/logo.

The error codes are broken down into categories. In each category, the number preceding each error message is the actual error code reported by the printer, and the error shown in bold is the error message printed.

Horizontal Line Errors

- 01 **HORiZontal line starting row SR out of bounds**
The row specified by the second parameter in the horizontal line command places the horizontal line outside the boundaries of the form.
- 02 **HORiZontal line starting column SC out of bounds**
The left (starting) column of the horizontal line specified by the third parameter in the horizontal line command places the horizontal line outside the boundaries of the form.
- 03 **HORiZontal line ending column EC out of bounds**
The right (ending) column of the horizontal line specified by the fourth parameter in the horizontal line command places the horizontal line outside the boundaries of the form.
- 04 **HORiZontal line format or delimiter error**
Some type of format or delimiter error was detected in the parameters of the horizontal line command. This error is usually caused by one or more of the following:
- a. A missing semicolon;
 - b. A colon in place of a semicolon;
 - c. Too many or too few parameters in the command string;
 - d. Alpha characters instead of numeric characters in the parameters.
- 05 **Insufficient memory to store the HORiZontal line**
No more room in the IGP memory exists for another horizontal line. The rest of the horizontal line commands are flushed until the Stop command is found. Processing will then continue normally. To create space in the IGP memory, delete forms with horizontal line elements that are no longer required.
- 06 **HORiZontal line starting column SC > ending column EC**
The left (starting) column parameter of the horizontal line command is greater than or equal to the right (ending) column parameter.
- 07 **HORiZontal line thickness LT error**
The thickness of the horizontal line specified by the first parameter in the horizontal line command is incorrect. This error is usually caused by specifying a thickness of zero.
- 08-09 Not defined.

Vertical Line Errors

- 10 **VERTical line starting column SC out of bounds**
The column specified by the second parameter in the vertical line command places the vertical line outside the form boundaries.
- 11 **VERTical line starting row SR out of bounds**
The upper (starting) row of the vertical line specified by the third parameter in the vertical line command places the vertical line outside the boundaries of the form.
- 12 **VERTical line ending row ER out of bounds**
The lower (ending) row of the vertical line specified by the fourth parameter in the vertical line command places the vertical line outside the boundaries of the form.
- 13 **VERTical line format or delimiter error**
Some type of format or delimiter error was detected in the parameters of the vertical line command. This error is usually caused by one or more of the following:
- a. A missing semicolon;
 - b. A colon in place of a semicolon;
 - c. Too many or too few parameters in the command string;
 - d. Alpha characters instead of numeric characters in the parameters.
- 14 **Insufficient memory to store the VERTical line**
No more room in the IGP memory exists for another vertical line. The rest of the vertical line commands are flushed until the Stop command is found. Processing will then continue normally. To create space in the IGP memory, delete forms with vertical line elements that are no longer required.
- 15 **VERTical line starting row SR > ending row ER**
The upper (starting) row parameter of the vertical line command is greater than or equal to the lower (ending) row parameter.
- 16 **VERTical line thickness LT error**
The thickness of the vertical line specified by the first parameter in the vertical line command is incorrect. This error is usually caused by specifying a thickness of zero.
- 17-19 Not defined.

Box Errors

- 20 **BOX starting column SC out of bounds**
The left (starting) column specified by the third parameter in the box command places the box outside the form boundaries.
- 21 **BOX starting row SR out of bounds**
The upper (starting) row of the box specified by the second parameter in the box command will place the box outside the boundaries of the form.
- 22 **BOX ending column EC out of bounds**
The right (ending) column specified by the fifth parameter in the box command places the box outside the form boundaries.
- 23 **BOX ending row ER out of bounds**
The lower (ending) row of the box specified by the fourth parameter in the box command will place the box outside the boundaries of the form.
- 24 **BOX format or delimiter error in input parameters**
Some type of format or delimiter error was detected in the parameters of the box command. This error is usually caused by one or more of the following:
- a. A missing semicolon;
 - b. A colon in place of a semicolon;
 - c. Too many or too few parameters in the command string;
 - d. Alpha characters instead of numeric characters in the parameters.
- 25 **Insufficient memory to store the BOX**
No more room in the IGP memory exists for another box. The rest of the box commands are flushed until the Stop command is found. Processing will then continue normally. To create space in the IGP memory, delete forms with box elements that are no longer required.
- 26 **BOX starting column SC > ending column EC**
The left (starting) column parameter of the box command is greater than or equal to the right (ending) column parameter.
- 27 **BOX starting row SR > ending row ER**
The upper (starting) row parameter of the box command is greater than or equal to the lower (ending) row parameter.
- 28 **BOX line thickness LT error**
The thickness of the box specified by the first parameter in the box command is incorrect. This error is usually caused by specifying a thickness of zero.
- 29 Not defined.

Corner Errors

- 30 **CORNER starting column SC out of bounds**
The left (starting) column specified by the third parameter in the corner command places the corner outside the form boundaries.
- 31 **CORNER starting row SR out of bounds**
The upper (starting) row of the corner specified by the second parameter in the corner command will place the corner outside the boundaries of the form.
- 32 **CORNER ending column EC out of bounds**
The right (ending) column specified by the fifth parameter in the corner command places the corner outside the form boundaries.
- 33 **CORNER ending row ER out of bounds**
The lower (ending) row of the corner specified by the fourth parameter in the corner command will place the corner outside the boundaries of the form.
- 34 **CORNER horizontal length HL out of bounds**
The length of the horizontal arms of the corner specified by the seventh parameter in the corner command will cause parts of the corner to extend outside the form boundaries.
- 35 **CORNER vertical length VL out of bounds**
The length of the vertical arms of the corner specified by the sixth parameter in the corner command will cause parts of the corner to extend above or below the boundaries of the form.
- 36 **CORNER format or delimiter error in input parameters**
Some type of format or delimiter error was detected in the parameters of the corner command. This error is usually caused by one or more of the following:
- a. A missing semicolon;
 - b. A colon in place of a semicolon;
 - c. Too many or too few parameters in the command string;
 - d. Alpha characters instead of numeric characters in the parameters.
- 37 **Insufficient memory to store the CORNER**
No more room in the IGP memory exists for another corner. The rest of the corner commands are flushed until the Stop command is found. Processing will then continue normally. To create space in the IGP memory, delete forms with corner elements that are no longer required.
- 38 **CORNER starting column SC > ending column EC**
The left (starting) column parameter of the corner command is greater than or equal to the right (ending) column parameter.
- 39 **CORNER starting row SR > ending row ER**
The upper (starting) row parameter of the corner command is greater than or equal to the lower (ending) row parameter.

Alpha Errors

- 40 **ALPHA leading and trailing delimiters mismatched**
The leading delimiter (printable character) of the actual text string was not matched with an ending delimiter before the line terminator was found.
- 41 **ALPHA starting row SR out of bounds**
The starting row parameter in the Alpha command will cause the text string to print either above or below the limits of the form.



Note Expanded print text strings expand up from the specified row. This could cause an attempt to print the text string above the top of the form and generate the error message.

- 42 **ALPHA starting column SC out of bounds**
The starting column parameter in the Alpha command is either extending the alpha string beyond the left margin of the form or the starting column parameter, plus the actual length of the text is extending the string beyond the right margin of the page.
- 43 **ALPHA string length > 255 characters**
The string contains more than 255 characters.
- 44 **ALPHA format or delimiter error in input parameters**
Some type of format or delimiter error was detected in the parameters of the alpha command. This error is usually caused by one or more of the following:
- a. A missing semicolon;
 - b. A colon in place of a semicolon;
 - c. Too many or too few parameters in the command string;
 - d. Alpha characters instead of numeric characters in the parameters.
 - e. Delimiter found within text string.
- 45 **Insufficient memory to store the ALPHA string**
No more room in the IGP memory exists for another alpha string. The rest of the Alpha commands are flushed until the Stop command is found. Processing of the form will then continue normally. To create space in the IGP memory, delete forms with alpha string elements that are no longer required.
- 46 **ALPHA X expansion HE and Y expansion VE must be zero**
When the expanded character parameters *VE* and *HE* are used within the ALPHA command, both values must be either zero or non-zero values. If the elongated characters parameter (E) or the compressed characters parameter (*Cn*) is used in the ALPHA command, the VE and HE values must be set to 0.
- 47 **ALPHA X expansion factor HE out of bounds (> 113)**
The horizontal expansion factor is greater than 113.
- 48 **ALPHA Y expansion factor VE out of bounds (> 113)**
The vertical expansion factor is greater than 113.

- 49 **ALPHA compression factor Cn error (10, 10A, 10B, 12, 13, 15, 17 or 20)**
The optional compression parameter (Cn) which defines the horizontal pitch of the text was specified incorrectly. The pitches available are 10, 10A, 10B, 12, 13, 15, 17 and 20.

Logo Errors

- 50 **LOGO horizontal width HL > 240 or dot col > HL**
a. The horizontal width of the logo is equal to zero or greater than 240. The IGP automatically reverts to Normal mode when this occurs.
b. A dot position specified in the logo program exceeds the specified horizontal width of the logo. When this occurs, the buffer is flushed until a line terminator is found, and then logo construction continues normally.
- 51 **LOGO vertical length VL > 252 or dot row n > VL**
a. The vertical length of the logo is equal to zero or greater than 252. The IGP automatically reverts to Normal mode when this occurs.
b. A dot row specified in the logo program exceeds the specified vertical length of the logo. When this occurs, the buffer is flushed until a line terminator is found, and then logo construction continues normally.
- 52 **LOGO hyphen syntax error in input parameters**
The beginning or ending dots are out of order, or a parameter is missing. The buffer is flushed until a line terminator is found, and then logo construction continues normally.
- 53 **Insufficient memory to create the LOGO**
No more room exists in IGP memory to construct a logo for the size specified. When this occurs, the IGP reverts to Normal mode. To create space in IGP memory, delete forms with logo elements (including the logos) that are no longer required.
- 54 **LOGO format or delimiter error**
Some type of format or delimiter error was detected in the Logo command. If this occurs while specifying the size and name of the logo, the IGP reverts to the Normal mode. If this occurs during the actual construction of the logo, the buffer is flushed until a line terminator is found, and then logo construction continues normally.
- 55 **LOGO call not previously defined**
An attempt was made in the Create Form mode to incorporate an undefined logo into a form. This error is not generated during the Logo Form mode. When this error occurs, the buffer is flushed until a line terminator is found, and then forms creation continues normally.

- 56 **Insufficient memory for another LOGO call**
IGP memory cannot store another logo call. To create space in the IGP memory, delete forms with logo elements (including the logos) no longer required.
- 57 **LOGO call starting row SR out of bounds**
During form creation, the parameter specifying the row position of a logo places the logo outside the form boundaries. The buffer is flushed until a line terminator is found, and then processing continues normally.
- 58 **LOGO call starting column SC out of bounds**
During form creation, the parameter specifying the column position of a logo places the logo outside the form boundaries. When this occurs, the buffer is flushed until a line terminator is found, and then processing continues normally.
- 59 **Color or GRAY scale not supported with LOGOS**
Color or gray information was received from the TIFF data, but it is not supported with the LOGO command.

Create Errors

- 60 **Directory full - cannot CREATE the form or LOGO**
The directory is full, or no more room exists in the IGP memory for another form. When this occurs, the IGP automatically reverts to the Normal mode. To create space in the IGP memory, delete forms that are no longer required.
- 61 **CREATE function unrecognized**
An unrecognizable command is entered during the Create Form mode. At this point, the buffer is flushed until a Stop command is found, and then processing continues.
- 62 **CREATE horizontal duplication parameter HDUP error**
Either a format error was detected or a parameter was exceeded. The duplication number must be no greater than 255, and the offset must be no greater than 792 (dot scale). If this error occurs, the Horizontal Duplication command is ignored, and forms processing continues.
- 63 **CREATE vertical duplication parameter VDUP error**
Either a format error was detected, or a parameter was exceeded. The duplication number must be no greater than 255 and the offset must be no greater than the specified length of the form. If this error occurs, the Vertical Duplication command is ignored, and forms processing continues.
- 64 **CREATE scale factor parameter SCALE invalid**
Either a format error was detected, or a parameter was specified incorrectly. The vertical lines per inch can be specified as follows; 6, 8, 9, or 10. The horizontal characters per inch can be specified only as 10, 12, 13, 15, 17 or 20 cpi. If this error occurs, the Scale command is ignored and forms processing continues.

- 65 **CREATE page starting row PAGE SR out of bounds**
When you specify the position of the page parameters with the Page command in the Create Form mode, the row position specified will place the page number above or below the boundaries of the form. When this error occurs, the IGP will automatically revert to the Normal mode.
- 66 **CREATE page starting column PAGE SC out of bounds**
When you specify the position of the page parameters in the Create command, the column position specified will place the page number outside the form boundaries. When this error occurs, the IGP will automatically revert to the Normal mode.
- 67 **CREATE STOP command missing**
This error occurs when the IGP receives a new function command, an End command, or a mode command without receiving a Stop command. The IGP will continue to process subsequent commands correctly.
- 68 **Insufficient memory to store the SETUP program**
No more room in the IGP/PGL memory exists for storing the SETUP routine.
- 69 **Insufficient memory to store the form**
The directory is full, or no more room exists in the IGP memory for another form. When this occurs, the IGP automatically reverts to the Normal mode. To create space in the IGP memory, delete forms that are no longer required.

Execute Errors

- 70 **EXECUTE form count parameter FC error**
This error occurs when the parameter specifying the number of blank forms to print was entered incorrectly. When this error occurs, the IGP will automatically revert to the Normal mode. Form count can be from 1 through 65,535.
- 71 **EXECUTE/DELETE form not found in the directory**
An attempt was made to execute or delete a form which does not exist in the forms directory. When this error occurs, the IGP reverts to the Normal mode.
- 72 **EXECUTE EVFU load error**
This error is generated only during the Execute Form mode while programming the EVFU. If more channels than lines per physical page are specified during a load sequence, this error is generated, and the IGP reverts to the Normal mode.
- 73 **EXECUTE EVFU terminator invalid**
This error is generated only during the Execute Form mode. The EVFU LOAD is missing an END LOAD code. If the line terminator cannot be deciphered, an error is generated, and the IGP reverts to the Normal mode.

- 74 **Missing delimiter - must be a single quotation mark**
When issuing an SFCC change command, the new SFCC character must be contained within two single quotation marks. If the new SFCC character is being identified by the ASCII value, no quotation marks are required.
- 75 Not defined
- 76 **EXECUTE page number error**
An error was made while specifying the page number used with the form being executed. This error can be generated because of incorrect format or a page number that is too large. The specified page number can range from 0 through 99,999,999. Since the page number is part of the Execute command, the IGP will revert to the Normal mode.
- 77 **EXECUTE format or delimiter error**
A format or delimiter error was detected in the Execute command; the IGP will revert to the Normal mode. This error is usually caused by one or more of the following:
- a. A missing semicolon;
 - b. A colon in place of a semicolon;
 - c. Too many or too few parameters in the command string;
 - d. Alpha characters instead of numeric characters in the parameters.
 - e. Page command misspelled when specifying the page number.
- 78 **Insufficient memory to EXECUTE the form**
Insufficient memory was available to recall and execute a form. The IGP will automatically revert to the Normal mode.
- 79 Not defined.

Miscellaneous Errors

- 80 **Special function must be called from the NORMAL mode**
This special function must be called from the Normal mode and not the Create Form or Execute Form mode. This error is generally due to a missing End command in the Create Form mode. For example, an attempt to enter the Create Form mode while executing a form will cause the IGP automatically to revert to the Normal mode.
- 81 **No such special function**
The special function call was unrecognizable. The IGP will automatically revert to the Normal mode.
- 82 **Numeric value expected in input parameter**
Characters other than numeric digits (0-9) are encountered where digits are expected.
- 83 **Decimal input error in input parameter**
The parameter expected was a decimal number. Either the number was not there, or it was too large (greater than 65,535). This error can also be caused by entering an alpha character instead of a numeric character.

- 84 **Missing or wrong delimiter - must be a semicolon ;**
The delimiter is either wrong or missing. The delimiter expected is a semicolon.
- 85 **Missing or wrong delimiter - must be a colon :**
The delimiter is either wrong or missing. The delimiter expected is a colon.
- 86 **DENSITY param error - 10, 10A, 10B, 12, 13, 15, 17 or 20**
The parameters of the Density command are improperly specified. The densities currently implemented are 10, 10A, 10B, 12, 13, 15, 17 and 20 characters per inch. The command is ignored and processing continues.
- 87 **LPI parameters error - must be 6, 8, 9, 10**
The parameters of the LPI command are improperly specified. The only parameters implemented are 6, 8, 9, and 10 lpi. The command is ignored and processing continues.
- 88 **Bar code type is not supported**
The specified bar code type is either misspelled or not supported.
- 89 **EXPAND parameters out of bounds or format error**
The parameters of the Expand command are improperly specified. Either the parameters are out of bounds, or some type of format error was detected. The command is ignored, and processing continues.

Bar Code Errors

- 90 **Insufficient memory to store the BARCODE**
No more room exists in the IGP memory for another bar code. The rest of the bar code commands are flushed until the Stop command is found. Then, processing continues.
- 91 **ALPHA/BARCODE syntax error**
Some type of syntax (format) error was detected in the parameters of the bar code command. This error is usually caused by one or more of the following:
- a. Misspelled keywords;
 - b. Lowercase used;
 - c. A missing semicolon;
 - d. A colon in place of a semicolon;
 - e. An ending delimiter for the data field was not found;
 - f. Too many or too few parameters in the command string.
- The rest of the command line is flushed until the Stop command is found. Processing will then continue.
- 92 **BARCODE magnification factor MAG out of bounds or not allowed**
The magnification factor specified in the bar code command is out of bounds. Refer to the applicable section in the "Bar Codes" chapter to determine the acceptable magnification values for the bar code symbol being used.

- 93 **BARCODE starting row SR out of bounds**
The starting row parameter in the bar code command will cause the bar code symbol to print either above or below the limits of the form.
- 94 **BARCODE starting column SC out of bounds**
The starting column parameter in the bar code command will cause the bar code symbol to print either beyond the left margin or the right margin of the form.
- 95 **BARCODE height Hn out of bounds - must be 3 through 99**
The height parameter specified in the bar code command is out of bounds. Acceptable values are 3 through 99.
- 96 **BARCODE data field has illegal character/format**
A character in the data field was not recognized as an acceptable character. Refer to the applicable section in the "Bar Codes" chapter to determine the acceptable characters for the bar code symbol being used. The missing ending delimiter also causes this error.
- 97 **BARCODE data field too short or too long**
The data field in the bar code command has too few or too many data characters. Refer to the applicable section in the "Bar Codes" chapter to determine the acceptable number of data characters for the bar code symbol being used.
- 98 **BARCODE symbol(s) exceeds the form length**
The bar code command causes a bar code symbol to print below the limits of the form. This error occurs on the data field line of the bar code.
- 99 **BARCODE symbol(s) exceeds the form width**
The bar code command causes a bar code symbol to print beyond the right margin. This error occurs on the data field line of the bar code.
- 100 **BARCODE variable ratio 0 or not ascending.**
For user-defined variable bar code ratios, either one of the ratios is zero or else an incorrect number of ratios was specified.
- 101 **BARCODE PDF not allowed or error - LOC: A or B - FONT: N, O, X, S, P, Q, R, T or V**
Either the alternate font was selected for a bar code or an invalid parameter was used. Acceptable parameters must be "N" for the normal font, "O" for the OCR-A optional font, "X" for the OCR-B optional font, or "S" to suppress printing of the data field, "P" for 12 cpi, "Q" for 13 cpi, "R" for 15 cpi, "T" for 17 cpi, "V" for 20 cpi.
- 102 **Dynamic BARCODE symbol exceeds the form length.**
The dynamic bar code command causes a bar code symbol to print below the limits of the form. This error occurs on the data field line of the bar code.
- 103 **Dynamic BARCODE symbol exceeds the form width**
The bar code command with a dynamic data field exceeds the limits of the current form width.

- 104 **Dynamic BARCODE data field BF_n not previously defined**
Dynamic data field designated in the Execute Form mode was not defined in the Create Form mode.
- 105 **Dynamic ALPHA/BARCODE field number AF_n/BF_n error - must be 1-512**
Dynamic alpha field number (AF_n) or bar code field number (BF_n) must range from 1 through 512.
- 106 Not defined.
- 107 **Dynamic ALPHA data field AF_n not previously defined**
The dynamic alpha field number called for was not previously defined in the Create Form mode.
- 108 Not defined.
- 109 **Dynamic ALPHA/BARCODE field longer than previously defined**
The BARCODE data provided exceeds the maximum length for the bar code selected.
- 110 **SFCC decimal input error - must be 1 - 255**
The hexadecimal value on the ASCII chart for the Special Function Control Character is not valid. Refer to page 86 to select a valid SFCC.

Reverse Print Errors

- 111 **REVERSE format error in input parameters**
Re-enter the command with proper format.
- 112 **REVERSE starting row SR/ending row ER out of bounds**
Exceeds the value specified to reverse the element.
- 113 **REVERSE starting SC/ending column EC out of bounds**
Exceeds the value specified to reverse the element.
- 114 **Insufficient memory to store the REVERSE element**
Insufficient memory space available for reversed print requirements.
- 115 **PDF417 bar code sizing parameter illegal or too small for data**
- 116 **PDF417 security level has illegal value or format**
- 117 **Unusable or illegal raster data.**
- 118 **Unsupported raster image type.**
- 119 **Unsupported raster compression type.**
- 120-121 Not defined.
- 122 **EXECUTE form too wide for current page setting**
The form was defined in one orientation while sent to print in another orientation. Use the debug slash (/) when creating a form to show which element is out of bounds (see page 314).

- 123 **EXECUTE form too long for current page setting**
The form was defined in one orientation while sent to print in another orientation. Use the debug slash (/) when creating a form to show which element is out of bounds.
- 124-125 Not defined.
- 126 **LFORMx form length parameter n error**
The number of lines exceeds 66 (for 6 lpi) or 88 (for 8 lpi) lines when using the LFORMx command.
- 127 Not defined.
- 128 **FORM/LOGO name is not a legal file name**
The file name exceeds the fifteen-character limitation, or an invalid character was used in the file name. Refer to IGP Command Standards in the "Commands" chapter.
- 129 Not defined.

Incremental Fields Errors

- 130 Not defined.
- 131 **Incremental STEPMASK parameter error**
A semicolon is missing after the STEPMASK data.
- 132 **Incremental REPEAT/RESET parameter error**
An illegal RPT or RST parameter value was found in the incremental command. The value must range from 1 through 65,535.
- 133 **Incremental STEPMASK/STARTDATA length error**
The dynamic stepmask exceeded created field length or start data exceeded stepmask.
- 134 **Incremental EXECUTE command error**
An illegal IRST or ICNT parameter value was found in the Execute command. The value must range from 1 through 65,535.
- 135 Not defined.
- 136 **Incremental STEPMASK/STARTDATA mismatched**
The STARTDATA value must be A-Z or 0-9, when the STEPMASK value is a value from 0-9.

Multinational Character Set Errors

- 150 **ISSET character selection parameter n error**
An ISSET character set selection parameter value was expected. Error was caused possibly by an invalid numeric value or an alpha character. See Chapter 5.
- 151 **USET decimal input error in input parameter**
The USET command was expecting a decimal parameter and either received none or received an alpha character.
- 152 **USET character set n parameter error**
A USET character set selection parameter value between 1 and 8

- was expected. Error was caused possibly by an invalid numeric value or an alpha character.
- 153 **USET substituted character illegal - must be 1 of 16**
 During character substitution in the USET command, the hex value for the character being replaced must be one of the specified 16 hex values. Only the following hex values (Ca) can be replaced by another hex value (Fa): 21, 22, 23, 24, 25, 26, 40, 5B, 5C, 5D, 5E, 60, 7B, 7C, 7D, 7E.
- 154 **USET defined character illegal - must be hex 20-FF**
 During the USET command, the hex value for the substituted character (Fa) must range between 20 and FF hex. The value given may be out of bounds.
- 155 **USET syntax error - END command is expected**
 An END command is expected when the USET character set definition is completed.
- 156 **No such CONFIGuration option**
- 157 **Left or Top/Bottom margin too large for the current page size.**
- 158-159 Not defined.

A

Standard ASCII Character Set

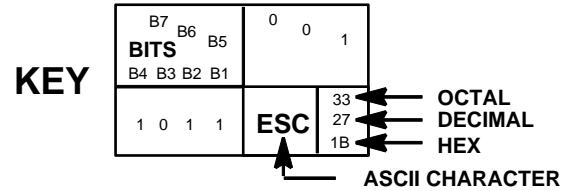

BITS B7 B6 B5 B4 B3 B2 B1	ROW	COLUMN		0		1		2		3		4		5		6		7	
		0	1	0	1	0	1	0	1	0	1	0	1	0	1	0	1	0	1
0 0 0 0	0	NUL	0 0 0	DLE	20 16 10	SP	40 32 20	0	60 48 30	@	100 64 40	P	120 80 50	`	140 96 60	p	160 112 70		
0 0 0 1	1	SOH	1 1 1	DC1 (XON)	21 17 11	!	41 33 21	1	61 49 31	A	101 65 41	Q	121 81 51	a	141 97 61	q	161 113 71		
0 0 1 0	2	STX	2 2 2	DC2	22 18 12	"	42 34 22	2	62 50 32	B	102 66 42	R	122 82 52	b	142 98 62	r	162 114 72		
0 0 1 1	3	ETX	3 3 3	DC3 (XOFF)	23 19 13	#	43 35 23	3	63 51 33	C	103 67 43	S	123 83 53	c	143 99 63	s	163 115 73		
0 1 0 0	4	EOT	4 4 4	DC4	24 20 14	\$	44 36 24	4	64 52 34	D	104 68 44	T	124 84 54	d	144 100 64	t	164 116 74		
0 1 0 1	5	ENQ	5 5 5	NAK	25 21 15	%	45 37 25	5	65 53 35	E	105 69 45	U	125 85 55	e	145 101 65	u	165 117 75		
0 1 1 0	6	ACK	6 6 6	SYN	26 22 16	&	46 38 26	6	66 54 36	F	106 70 46	V	126 86 56	f	146 102 66	v	166 118 76		
0 1 1 1	7	BEL	7 7 7	ETB	27 23 17	,	47 39 27	7	67 55 37	G	107 71 47	W	127 87 57	g	147 103 67	w	167 119 77		
1 0 0 0	8	BS	8 8 8	CAN	30 24 18	(50 40 28	8	70 56 38	H	110 72 48	X	130 88 58	h	150 104 68	x	170 120 78		
1 0 0 1	9	HT	9 9 9	EM	31 25 19)	51 41 29	9	71 57 39	I	111 73 49	Y	131 89 59	i	151 105 69	y	171 121 79		
1 0 1 0	10	LF	10 10 0A	SUB	32 26 1A	*	52 42 2A	:	72 58 3A	J	112 74 4A	Z	132 90 5A	j	152 106 6A	z	172 122 7A		
1 0 1 1	11	VT	11 11 0B	ESC	33 27 1B	+	53 43 2B	;	73 59 3B	K	113 75 4B	[133 91 5B	k	153 107 6B	{	173 123 7B		
1 1 0 0	12	FF	12 12 0C	FS	34 28 1C	,	54 44 2C	<	74 60 3C	L	114 76 4C	\	134 92 5C	l	154 108 6C		174 124 7C		
1 1 0 1	13	CR	13 13 0D	GS	35 29 1D	-	55 45 2D	=	75 61 3D	M	115 77 4D]	135 93 5D	m	155 109 6D	}	175 125 7D		
1 1 1 0	14	SO	14 14 0E	RS	36 30 1E	.	56 46 2E	>	76 62 3E	N	116 78 4E	^	136 94 5E	n	156 110 6E	~	176 126 7E		
1 1 1 1	15	SI	15 15 0F	US	37 31 1F	/	57 47 2F	?	77 63 3F	O	117 79 4F	_	137 95 5F	o	157 111 6F	DEL	177 127 7F		

B

Grid Programs and Samples

The Standard Grid. The standard grid is used for form design. The program for the standard grid is listed below, and a sample of the standard grid follows on the next page. Photocopy the grid provided or enter the grid program and make your own printout.

```
~CREATE:GRID
HDUP:75:1
VERT
1:1:1:61
STOP
HDUP:OFF
HDUP:7:10
VERT
1:5:1:61.5
2:10:1:61.5
STOP
HDUP:OFF
VERT
2:75:1:61.5
STOP
VDUP:61:1
HORZ
1:1:1:75
STOP
VDUP:OFF
VDUP:6:10
HORZ
1:5:1:76
2:10:1:76
STOP
VDUP:OFF
VERT
2:1:1:61.3
STOP
HORZ
2:1:1:75
STOP
VDUP:12:5
ALPHA
I:5.5:76:0:0:05;" 5"
STOP
VDUP:OFF
HDUP:14:5
ALPHA
C15:I:61.9:5:0:0:05;" 5"
STOP
HDUP:OFF
END

~EXECUTE:GRID:1
```

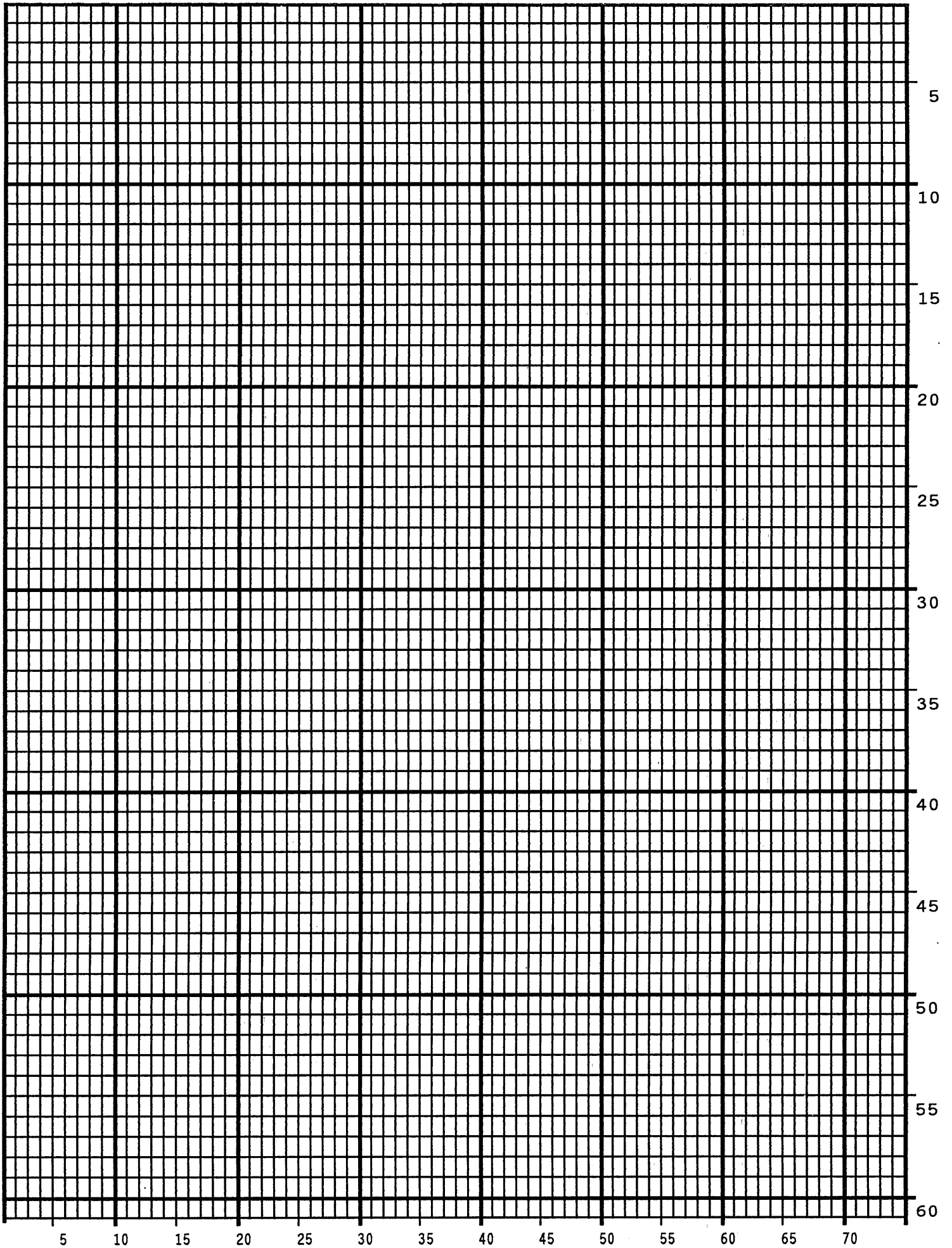

The Logo Grid. The program for a logo grid is listed below and the sample grid follows. It is not the full size logo grid; the grid can measure up to 240 columns wide by 252 rows high for a logo 4 x 3.5 inches. Photocopy the grid or enter the grid program to obtain a printout.

```
~CREATE;LOGOGRID
HDUP;75;1
VERT
1;4;4;56
STOP
HDUP;OFF
HDUP;5;15
ALPHA
C17;I;3;8.2;0;0;15;"05"
C17;I;3;13.2;0;0;15;"10"
I;3;18.2;0;0;15;"15"
STOP
VERT
2;18;3.5;56
1;8;3.9;56
1;13;3.9;56
STOP
HDUP;OFF
VDUP;105;0.6
HORZ
1;4;4;78
STOP
VDUP;OFF
VDUP;7;7.6
ALPHA
C17;I;5.11;79;0;0;015;" 5"
C17;I;8.6;79;0;0;015;" 10"
C13;I;11.5;78.2;0;0;015;"15"
STOP
HORZ
2;10.11;4;79.5
1;6;4;79
1;8.6;4;79
STOP
VDUP;OFF
END
~EXECUTE;LOGOGRID;1
```

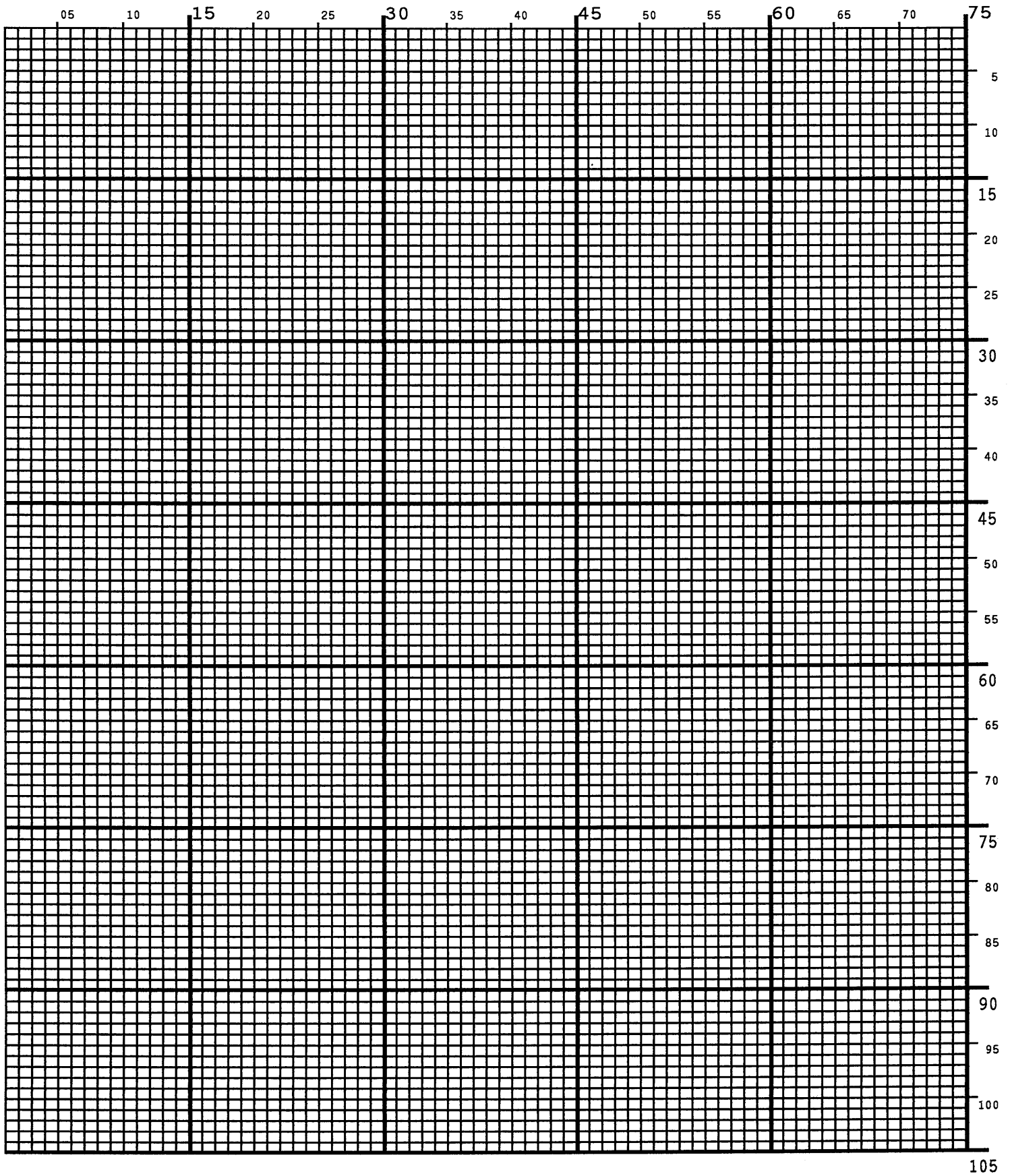

C

Vertical Paper Motion

Introduction

There are three methods of advancing the print position with the IGP which are explained in this appendix:

1. Using line feeds or form feeds;
2. Using the paper instruction (PI) line; or
3. Using the Electronic Vertical Format Unit (EVFU).

Paper Motion Using Line Feeds and Form Feeds

The most common method of advancing the print position with IGP is through the use of line feeds and form feeds. A line feed moves the print position down a distance determined by the current line spacing (lpi). In the Normal mode, a form feed character advances the print position to the top of the next page; in the Execute mode, a form feed advances the print position to the top of the next *form*. Form length is determined by the CREATE command.

Paper Motion Using the PI Line (Relative Line Slewing)

The method of moving the print position using the PI line results in vertical slews of a specified number of lines relative to the current print position (rather than slewing to a specific line). For this to occur, the following criteria must be met:

1. The PI line must be enabled and set high; and
2. Data bit 5 must be 1 (set).

When a number of blank lines will be skipped on a form, (called "paper slewing") another method of paper motion may be used. The PI signal can be detected by the IGP as the 8th data bit in a serial interface, or a separate input line in a parallel interface. (Refer to the EN-PI/DIS-PI command and the PION/PIOFF commands on page 79.) When the PI signal is used, bits 6 and 7 are interpreted as 0 values, and characters hex 10 through 1F are interpreted as binary slew commands.

The binary slew commands can skip from 1 through 15 or 1 through 16 lines on the form, depending on how the Slew Range configuration option is configured. Refer to Table 24 which illustrates how lines are skipped for each value. (Note that the state of data bit 5 is the difference between line slewing and using the interface lines as EVFU channel codes.) This type of vertical paper motion occurs whenever the line slewing command is used regardless of whether the EVFU memory is loaded or not.

Table 24. Line Space Slewing

ASCII			Data Bits								Slew Range Configuration Value	
Hex	Dec	Code	8*	7	6	5	4	3	2	1	0	1
10	16	DLE	1	X	X	1	0	0	0	0	1	1
11	17	DC1	1	X	X	1	0	0	0	1	2	1
12	18	DC2	1	X	X	1	0	0	1	0	3	2
13	19	DC3	1	X	X	1	0	0	1	1	4	3
14	20	DC4	1	X	X	1	0	1	0	0	5	4
15	21	NAK	1	X	X	1	0	1	0	1	6	5
16	22	SYN	1	X	X	1	0	1	1	0	7	6
17	23	ETB	1	X	X	1	0	1	1	1	8	7
18	24	CAN	1	X	X	1	1	0	0	0	9	8
19	25	EM	1	X	X	1	1	0	0	1	10	9
1A	26	SUB	1	X	X	1	1	0	1	0	11	10
1B	27	ESC	1	X	X	1	1	0	1	1	12	11
1C	28	FS	1	X	X	1	1	1	0	0	13	12
1D	29	GS	1	X	X	1	1	1	0	1	14	13
1E	30	RS	1	X	X	1	1	1	1	0	15	14
1F	31	US	1	X	X	1	1	1	1	1	16	15

X = Undefined, 0 or 1 1 = High 0 = Low

Note



*The ASCII values in Table 24 assume that all undefined bits are set to 0. When the PI line is enabled, data bit 8 is the PI line on a serial interface, and data bit 8 is undefined on a parallel interface.

Paper Motion Using the EVFU

The Electronic Vertical Format Unit (EVFU) is an efficient method of skipping to a specified print position during repetitive printing tasks. The EVFU affects the vertical placement of overlay data produced in the Execute Form mode.

General EVFU Programming

The general EVFU programming procedure is as follows:

1. Design a form, determining spacing and channel assignments for each line.
2. Send the programming sequence to the printer.

The following information applies when programming and using the EVFU:

PI Line. The PI signal can be detected by the IGP as the 8th data bit in a serial interface, or a separate input line in a parallel interface. (Refer to the EN-PI/DIS-PI command and the PION/PIOFF commands on page 79.)

Elongated Characters. Elongated (double high) characters can be used within EVFU programs. The EVFU automatically counts one line of elongated characters as two normal character lines.

Paper Runaway Protection. If the EVFU is selected but not loaded when an EVFU command is sent from the host computer, the printer moves the paper a single line feed. If the EVFU is selected and the memory is loaded, a channel code sent from the host, which is not a part of the assigned sequence currently in memory, moves the paper a single line feed.

Line Spacing. The printer can use any line spacing with the EVFU. The EVFU determines the forms length according to the program specifications and the currently selected line spacing. For example, 14-inch paper with 10 lpi line spacing would yield a 140-line form which can be defined by the EVFU. Mixing line spacing on the same form unloads the EVFU.

EVFU Programming Sequence

The EVFU provides 16 channels to identify up through 192 lines. An error results if the EVFU form length exceeds the physical length of the page, and the IGP returns to the Normal mode. The number of channels in an EVFU overrides the length of the form as it was defined in the CREATE mode; therefore, the EVFU must be equal to or longer than the form being used.

The EVFU programming sequence is listed below and explained in the following sections.

1. Start load code;
2. Line identification codes; and
3. End load code.

Start Load Code - 1E or 6E Hex

The Start Load code clears and initializes the EVFU memory for channel assignment storage. Refer to Table 25 or Table 26 for the appropriate start load code.

Channel Assignment

The EVFU memory has the capacity for 92-line forms. The first line identification code (channel code) in the EVFU load data defines the first line on the form; the second line identification code defines the second line on the form, etc. Each line must have a line identification code.

A single channel code is used repeatedly throughout a form to reserve blank lines between defined channel codes and to maintain the correct forms length. These “filler” channels can be any channel number except channel code 1 (which is reserved for the top-of-form) and channel code 12 (which is reserved as the vertical tab channel). In the EVFU example which begins on page 289, filler channels are represented by a hex 11 code. Calls are rarely made to filler channels because they do not specify a unique print position on the form.

Channel 1 — The top-of-form code, reserved as the first line on the form. The operating program sends the channel 1 code to advance to the top of the next form. After the memory is loaded, a Form Feed code (FF, 0C hex) moves the paper to the next channel 1 (top-of-form).

Channels 2 through 11, 13 and 14 — Used as general channel codes (also referred to as line identification codes) or as filler channels. Each line on the form must be identified by a channel code. When the operating program sends the channel code, the paper advances to the line identified by the channel code.

Channel 12 — Reserved as the vertical tab channel. The vertical tab code (VT, 0B hex) rapidly advances the print position to the next line identified by the channel 12 code. If channel 12 is not loaded in the EVFU memory, a single line feed is executed when a VT code is sent.

End Load - 1F or 6F Hex

The end load code terminates the channel storage and saves the EVFU in memory. Refer to Table 25 or Table 26 for the appropriate end load code. Channel codes in excess of 192 channels received prior to the end load code cause an EXECUTE EVFU load error.

Using the EVFU

Sending the appropriate EVFU channel code to the printer causes any data in the buffer to print and slew the paper to the next line on the form having the specified channel number assigned in EVFU memory.

To recognize a data byte as an EVFU instruction, one of the following sets of criteria must be met:

1. The PI line must be enabled and set high;
2. Bits 7 and 6 can be set to 1 or 0; and

3. Data bit 5 must be 0 (not set).

OR:

1. The PI line must be disabled or low;
2. Bits 7 and 6 must be 0 (not set); and
3. Data bit 5 must be 1 (set).

Given these conditions, the lower four bits of a byte specify the EVFU channel number. Table 25 lists the EVFU channels and their equivalent data bytes when the PI line is enabled; Table 26 lists the EVFU channel and their equivalent data bytes when the PI line is disabled.

Table 25. EVFU Codes — PI Line Enabled

ASCII			Data Bits							Channel	
Hex	Dec	Code	8*	7	6	5	4	3	2	1	
00	0	NUL	1	X	X	0	0	0	0	0	1 (TOF)
01	1	SOH	1	X	X	0	0	0	0	1	2
02	2	STX	1	X	X	0	0	0	1	0	3
03	3	ETX	1	X	X	0	0	0	1	1	4
04	4	EOT	1	X	X	0	0	1	0	0	5
05	5	ENQ	1	X	X	0	0	1	0	1	6
06	6	ACK	1	X	X	0	0	1	1	0	7
07	7	BEL	1	X	X	0	0	1	1	1	8
08	8	BS	1	X	X	0	1	0	0	0	9
09	9	HT	1	X	X	0	1	0	0	1	10
0A	10	LF	1	X	X	0	1	0	1	0	11
0B	11	VT	1	X	X	0	1	0	1	1	12 (VT)
0C	12	FF	1	X	X	0	1	1	0	0	13
0D	13	CR	1	X	X	0	1	1	0	1	14
0E	14	SO	1	0	0	0	1	1	1	0	15
0F	15	SI	1	0	0	0	1	1	1	1	16
6E	110	n	1	1	1	0	1	1	1	0	Start Load
6F	111	o	1	1	1	0	1	1	1	1	End Load
X = Undefined, 0 or 1				1 = High				0 = Low			

Note



*The ASCII values in Table 25 assume that all undefined bits are set to 0. When the PI line is enabled, data bit 8 is the PI line on a serial interface, and data bit 8 is undefined on a parallel interface.

Table 26. EVFU Codes — PI Line Disabled or Not Used

ASCII			Data Bits							Channel	
Hex	Dec	Code	8	7	6	5	4	3	2	1	
10	16	DLE	0	0	0	1	0	0	0	0	1 (TOF)
11	17	DC1	0	0	0	1	0	0	0	1	2
12	18	DC2	0	0	0	1	0	0	1	0	3
13	19	DC3	0	0	0	1	0	0	1	1	4
14	20	DC4	0	0	0	1	0	1	0	0	5
15	21	NAK	0	0	0	1	0	1	0	1	6
16	22	SYN	0	0	0	1	0	1	1	0	7
17	23	ETB	0	0	0	1	0	1	1	1	8
18	24	CAN	0	0	0	1	1	0	0	0	9
19	25	EM	0	0	0	1	1	0	0	1	10
1A	26	SUB	0	0	0	1	1	0	1	0	11
1B	27	ESC	0	0	0	1	1	0	1	1	12 (VT)
1C	28	FS	0	0	0	1	1	1	0	0	13
1D	29	GS	0	0	0	1	1	1	0	1	14
1E	30	RS	0	0	0	1	1	1	1	0	Start Load
1F	31	US	0	0	0	1	1	1	1	1	End Load
X = Undefined, 0 or 1			1 = High							0 = Low	

Note



Do not use your SFCC as a channel code when using the EVFU.

Clearing the EVFU Memory

The following actions reset (clear) the EVFU memory:

1. Sending only the start load code.
2. Sending a start load code followed immediately by an end load code.
3. A second start load code is received, resulting in re-initialization of the EVFU. (This restarts the EVFU load sequence.)

When the EVFU memory is cleared, the forms length returns to the previously set value.

EVFU Example

The following EVFU example is a 2-inch form at 6 lpi line spacing. Thus, 12 lines on the form must be defined. The form is repeated 3 times. Paper instructions are disabled.

Assign Line Identification Codes

Line ID Code	Description	Assigned Hex Code
Start Load	Start EVFU	1E
Line 1	Top of Form	10
Line 2	Filler	11
Line 3	Filler	11
Line 4	Filler	11
Line 5	Vertical Tab	1B
Line 6	First channel stop	13
Line 7	Filler	11
Line 8	Filler	11
Line 9	Second channel stop	12
Line 10	Filler	11
Line 11	Third channel stop	15
Line 12	Filler	11
Stop Load	End EVFU	1F

EVFU Format in Execute Mode

The Execute command shown on the next page, derived from the Execute command format on page 59, illustrates how the EVFU data above is incorporated into the Execute command. All other Execute command parameters are shown in italics. (Optional parameters are shown in brackets [].) Figure 58 on page 291 illustrates the printed output from this data.

The boldface line below the EXECUTE command represents the hexadecimal EVFU load sequence which identifies the channel codes at which overlay data will be placed on each form. The example hex values correspond to the line identification codes listed above. Channel codes not described above as Filler channels are assigned unique hex codes. Calls to these channels will print overlay data at specific positions on the form.

The two *~AF* lines, also shown in italics, represent the dynamic data. While the EVFU does not affect dynamic data positioning (data placement is defined by the ALPHA statement when the form was created), the commands are shown to specify where they would occur in relation to the EXECUTE command, the EVFU load sequence, and the overlay data.

The four lines of EVFU overlay data (shown in **boldface** type) follow the two lines of dynamic data. This overlay data is positioned on the form according to the specified channel codes called. The superscript hexadecimal numbers enclosed in < > symbols represent calls to the four unique EVFU channel codes.

```
(cc)EXECUTE; formname [;PAGE n] [;FC] [;ICNTn] [;IRSTn]
1E 10 11 11 11 1B 13 11 11 12 11 15 11 1F
~AF1;*DYNAMIC DATA #1*
~AF2;*DYNAMIC DATA #2*
<13>DATA FOR LINE 6<17>
<10><12>DATA FOR LINE 9
<1B>DATA FOR VERTICAL TAB CHANNEL
<15>DATA FOR LINE 11
[Form Feed character]
```

(cc)NORMAL

When the IGP receives a channel call, it searches for that channel from the current print position in the EVFU load sequence to the end of the EVFU load sequence. If that channel is found, the current print position moves to that position on the page. If the channel is not found, the search continues from the beginning of the EVFU load sequence to the current print position. If this search is successful, the current form is printed, the next form is called, and the current print position moves to that position on the next page. If the channel called is not found in either search, the channel call is treated as if it were a line feed.

	EVFU Channel Code Sent	Line No.	Form Output
	1E	Start Load	
Form #1	10	1 (TOF)	<i>(top of form, Form #1)</i>
	11	2	
	11	3	
	11	4	
	1B	5	
	13	6	DATA FOR LINE 6
	17	7	<i>(undefined hex 17 causes single line feed)</i>
	11	8	
	12	9	
	11	10	
	15	11	
	11	12	
Form #2	10	1 (TOF)	<i>(top of form, Form #2)</i>
	11	2	
	11	3	
	11	4	
	1B	5	
	13	6	
	11	7	
	11	8	
	12	9	DATA FOR LINE 9
	11	10	
	15	11	
	11	12	
Form #3	10	1 (TOF)	<i>(top of form, Form #3)</i>
	11	2	
	11	3	
	11	4	
	1B	5	DATA FOR VERTICAL TAB CHANNEL
	13	6	
	11	7	
	11	8	
	12	9	
	11	10	
	15	11	DATA FOR LINE 11
	11	12	
	1F	End Load	

Figure 58. Sample EVFU Form

Index

A

Alphanumeric

- command, 29
- data, 27
- duplicating incremental fields, 41
- dynamic data, 234
- errors, 266
- execute dynamic data, 62
- execute overlay data, 67
- increment fixed data, 38
- incremental commands, 34
- incremental dynamic data, 40, 66

Alphanumeric Data, 27

- dynamic data, 27
- fixed data, 27
- incremental data, 27
- overlay data, 27

Application identifiers

- UCC/EAN-128, 174

ASCII Character Set, 277

Auto Increment Example, 225

B

Bar Code

- duplicating incremental fields, 214
- errors, 271
- execute dynamic data, 63
- features, 14
- incremental dynamic data, 66, 212
- incremental fields, 208
- overview, 87
- user-defined, 89

Bar Code Command, 233

Bar Codes

Codabar, 91

Code 128A, 108

Code 128B, 108

Code 128C, 108

Code 39, 96

Code 93, 102

EAN 13, 123

EAN 8, 118

FIM, 129

German I-2/5, 135

I-2/5, 135

Interleaved 2/5, 135

ITF-14, 135

Matrix, 141

MSI, 147

PostBar, 163

POSTNET, 158

Royal Mail, 163

Telepen, 167

UCC/EAN-128, 173

UPC-A, 185

UPC-E, 191

UPCSHIP, 198

UPS 11, 203

Batch form processing, 14

Bold Print See Font, 69

Box command, 43

Box Errors, 264

C

Channel assignments

EVFU, 286

Character Position Dot Position (CP.DP) Format, 26

Character Set

ASCII, 277

Character Sets

- accessing, 253
- extended, 14
- multinational, 14
- OCR, 253
- user-defined, 254

Character Sizes

- Printable Data in Barcodes, 90

Characters

- height/width, 14
- printable, 24
- rotated, 14
- Special Function Control Character, 23

Clearing EVFU memory, 288

Codabar, 91

- command format, 92
- example, 95

Code 128A, 108

Code 128B, 108

- command format, 110
- example, 116

Code 128C, 108

- example, 117

Code 39, 96, 233

- command format, 98
- example, 101
- structure, 96

Code 93, 102

- example, 107
- structure, 102

Command Parameters, 24

Command Standards

- comments in command lines, 25
- numeric values, 25
- prompt, 25

Commands

- alphanumerics, 29
- Bar Code, 233
- box, 43
- Codabar, 92
- Code 128B, 110
- Code 39, 98
- comments in command line, 25
- Compressed Print, 45
- Configuration (CONFIG), 46
- Corner, 49
- Create, 51
- Create Form Mode, 18, 19
- Create Logo, 76, 237
- Data Bit 8, 79
- Delete Form, 52
- Delete Logo, 53
- density, 45
- Directory, 53
- directory, 247
- Duplicating Incremental Alphanumerics, 41
- EAN 13, 125
- EAN 8, 120
- Emulation Switching, 57
- Enable/Disable PI, 80
- End, 57
- Execute Dynamic Alphanumeric Data, 62
- Execute Dynamic Bar Code Data, 63
- Execute Form Mode, 21, 234
- Execute Incremental Dynamic Data, 65
- Expanded Print, 68
- FIM, 131
- Font, 69
- Form Length, 70
- form name, 24
- format, 23
- German I-2/5, 137
- Horizontal Duplication, 54
- Horizontal Lines, 72
- I-2/5, 137
- Ignore Sequence (IGON/IGOFF), 71
- Incremental Alphanumerics, 34
- Incremental Alphanumerics Dynamic Data, 40
- Incremental Alphanumerics Fixed Data, 38
- Incremental Barcode Fixed Data, 211
- Incremental Dynamic Alphanumeric Data, 66
- Incremental Dynamic Bar Code Data, 66
- inline commands, 23

ITF-14, 137
 line printer emulation, 74
 Line Spacing, 71
 line terminator, 24
 Listen, 74
 Logo Call, 74
 Matrix, 143
 MSI, 149
 Normal Mode, 16, 17, 78
 Page Number, 78
 Paper, 79
 Paper Instruction, data bit 8, 79
 parameters, 24
 PDF417, 153
 PostBar, 164
 POSTNET, 161
 Print File, 80
 printable character, 24
 Quiet, 81
 Reset, 82
 Reverse Print, 82
 Royal Mail, 164
 Scale, 83
 Select Format, 84
 semicolon, 23
 Setup, 81
 spaces, 24
 Special Function Control Character, 23
 Telepen, 169
 UPC-A, 187
 UPC-E, 193
 UPCHIP, 200
 uppercase, 23
 UPS 11, 204
 Vertical Duplication, 56, 243
 Vertical Lines, 73
 Comments
 in command line, 25
 Compressed Print, 29
 Compressed Print Command, 45
 Configuration Command, 46
 Corner Command, 49
 Corner Errors, 265
 CP.DP Format, 26
 Create
 character sets, 14
 Create Command, 51
 Create Errors, 268
 Create Form Mode, 18
 Create Form Mode Commands, 19
 Create Logo Mode, 18, 76
D
 Dark Printing, 28
 Data
 alphanumeric, 22, 27
 dynamic, 22
 fixed, 22
 incremental, 22, 27
 overlay, 22
 placement, 22
 prepositioned, 22
 rotated, 14
 storing, 25
 Data Bit 8
 multinational character sets, 253
 paper instruction command, 79
 Data Field
 updating, 22
 Debug Parameter, 51
 Debugging Program Errors, 248
 Debugging Programs, 261
 Deleting
 example, 248
 forms, 52
 logos, 53
 Density, 29, 83
 Density Command, 45
 Designing Forms, 239
 Directory Command, 53, 247
 Disable IGP (quiet command), 81
 DISK Parameter, 25
 DIS-PI, 80
 Double-strike Printing (DARK), 28
 Duplicating Incremental Bar Codes, 214

Dynamic Alphanumeric Data, 27, 29, 234

E

EAN 13, 123

- command format, 125
- example, 128
- structure, 123

EAN 8, 118

- command format, 120
- example, 122
- structure, 118

Electronic Vertical Format Unit

- format, 285

Electronic Vertical Format Unit (EVFU), 61

Elongated Characters, 29

Emulation Switching Command, 57

Enable IGP (listen command), 74

Enable/Disable PI, 80

End Command, 57

End Load Code, 286

EN-PI, 80

Error Codes

- purpose, 261

Errors, 262

- alphanumerics, 266
- bar code, 271
- box, 264
- corners, 265
- create, 268
- execute, 269
- horizontal line, 262
- incremental fields, 274
- logo, 267
- miscellaneous, 270
- multinational character set, 274
- reverse print, 273
- solving program, 248
- vertical lines, 263

EVFU, 61, 285

- channel assignment, 286
- clearing memory, 288
- data, 60
- example, 289

General programming information, 285

memory, clearing, 288

programming sequence See EVFU, 285

start load code, 286

Examples

auto increment fields, 225

Create Logo, 236

directory, 247

dynamic data, 218

EVFU, 289

forms, 215

logo grid, 281

PostBar, 166

Royal Mail, 166

standard grid, 279

UCC/EAN-128, 182

Execute, 59

Dynamic Alphanumerics, 60, 62

Dynamic Bar Codes, 60, 63

Dynamic Logo, 60

Incremental Dynamic Alphanumerics, 60

Incremental Dynamic Bar Codes, 60

Overlay Data, 60, 67

Execute Dynamic Alphanumeric Data, 62

Execute Dynamic Bar Code Data, 63

Execute Dynamic Logo, 64

Execute Errors, 269

Execute Form

dynamic alphanumeric data, 62

dynamic bar code data, 63

Dynamic Logo, 64

EVFU, 61

general format, 59

incremental dynamic data, 65

overlay data, 67

Execute Form Mode, 20, 58, 234

EVFU, 60

Execute Form Mode Commands, 21

Execute Incremental Dynamic Data, 65

Execute Overlay Data, 67

Expanded Print, 68

Extended Character Sets, 251

ISET command, 256

F

Features

- alphanumeric data, 14
- graphic capabilities, 14
- IGP/PGL emulation, 13
- incremental data, 22

FIM, 129

- command format, 131
- example, 133
- structure, 129

Fixed Alphanumeric Data, 27

Font Command, 69

Form Count, 59

Form Design, 239

Form Examples

- create basic form, 215

Form feed, paper motion using, 283

Form Layout, planning, 239

Form Length, 51

Form Length Command, 70

Form Name, 24, 51, 59

Format

- commands, 23

G

German I-2/5, 135

Graphic

- scaling capabilities, 14

H

HDUP Command, 54

Horizontal Duplication Command, 54

Horizontal Line Errors, 262

Horizontal Lines Command, 72

HORZ Command, 72

I

I-2/5

- command format, 137
- example, 140
- structure, 135

ICNT Parameter, 59, 65

idir parameter, 38, 66

Ignore Sequence Command (IGON/IGOFF), 71

IGON/IGOFF Command, 71

IGP

- modes, 15
- operation, 14

Increment Form Count Parameter, 59, 65

Increment Reset Parameter, 59, 60, 65

Increment/decrement capability, 14

Incremental Alphanumeric Data, 27

Incremental Bar Code Fields, 208

Incremental Barcode Dynamic Data, 212

Incremental Barcode Fixed Data, 211

Incremental Dynamic Barcodes, 213

Incremental Fields Errors, 274

Incremental Fields Example, 225

Incrementing Alphanumeric Data, 34

Inline Commands, 23

Interleaved 2/5, 135

IRST Parameter, 59, 60, 65

ISET Command, 256

Italic Print, 69

ITF 14, 135

L

Layout, page, 239

Line feed, paper motion using, 283

Line Printer Emulation Commands, 74

Line Spacing, 71, 83

Line Spacing Command, 71

Listen Command, 74

Logo, 236

- Create command, 237
- creating, 236
- define, 237, 239
- features, 14

Logo Call Command, 74

Logo Errors, 267

Logos, deleting, 53

LPI, 83

M

- Matrix, 141
 - commands, 143
 - example, 146
 - structure, 141
- Memory, 25
- Miscellaneous Errors, 270
- Mode
 - Create Logo, 236
 - Execute Form, 234
- Modes
 - Create Logo, 76
 - Execute Form, 58
 - Normal, 78
- Modes of Operation
 - Create Form, 18
 - Create Logo, 18
 - Execute Form, 20
 - introduction, 15
 - Normal, 16
- MSI, 147
 - command format, 149
 - example, 152
 - structure, 147
- Multinational Character Set
 - features, 251
 - OCR character sets, 253
 - user-defined sets, 254
- Multinational Character Set Errors, 274
- Multinational Character Sets
 - data bit 8, 253
 - ISET command, 256
 - power-up selection, 253

N

- Normal Mode, 16, 78
- Numeric Values
 - used in command format, 25

O

- OCR Character Sets, 253
- Overlay Alphanumeric Data, 27

P

- Page Layout Considerations, 239
- Page Number Command, 78
- Pagination, 59, 78
- Paper Command, 79
- Paper motion, vertical, 283
- PDF417
 - command format, 153
 - example, 157
- PI line paper motion, 283
- PION/PIOFF Command, 79
- Point Size, 69
- PostBar, 163
 - command format, 164
 - example, 166
- POSTNET, 158
 - command format, 161
 - structure, 158
- Power-Up Character Set Selection
 - multinational character sets, 253
- Print
 - boundaries, 18
 - reversed, 14
- Print File Command, 80
- Printable Character Delimiter, 24
- Printable Data Field, Character Sizes, 90
- Prompt, 25

Q

- Quiet Command, 81

R

- Relative line slewing (PI line), 283
- Repeat Count Parameter, 38, 66, 211
- Reset Command, 82
- Reset Count Parameter, 39, 67, 211
- Reverse Print, 29
- Reverse Print Command, 82
- Reverse Print Errors, 273
- Rotated Characters, 30
- Royal Mail, 163
 - command format, 164

example, 166
RPT Parameter, 38, 66, 211
RST Parameter, 39, 67, 211

S

Scale Command, 83
Scaling
 capabilities, 14
Select Format Command, 84
Semicolon, 23
SETUP Command, 81
Setup Files Feature, 85
SFCC, 23
SFON/SFOFF Command, 84
Slant (italic) Print, 69
Special Function Control Character (SFCC), 23
Standard Command Format
 UCC/EAN-128, 179
Start load code, 286
 EVFU, 286
STARTDATA Parameter, 39, 67, 212
STEPMASK Parameter, 38, 66, 211
Storing Data, 25
Symbol Set See Configuration, ISET, USET, 69
Symset, 69

T

Telepen, 167
 command format, 169
 example, 172
 structure, 167
Terminator, line, 24

U

UC Parameter, 30
UCC/EAN-128
 application identifiers, 174
 examples, 182

standard command format, 179
structure, 173

UPC-A, 185
 command format, 187
 example, 190
 structure, 185

UPC-E, 191
 command format, 193
 example, 197
 structure, 191

UPCSHIP, 198
 command format, 200
 example, 202
 structure, 198

Uppercase, 23
Uppercase Parameter, 30
UPS 11, 203
 command format, 204
 example, 207
 structure, 203

User-Defined Bar Code
 variable ratio size (D), 89
User-Defined Character Sets
 multinational, 254
USET Command, 254

V

Variable Ratio Size (D)
 user-defined bar code, 89
VDUP Command, 56
VERT Command, 73
Vertical Duplication Command, 56, 243
Vertical Formatting, 61
Vertical Line Errors, 263
Vertical Lines Command, 73
Vertical paper motion, 283



Copyright© 2000
Hewlett-Packard Company

**Manual Part Number
171250-001PX**

171250-001A

Free Manuals Download Website

<http://myh66.com>

<http://usermanuals.us>

<http://www.somanuals.com>

<http://www.4manuals.cc>

<http://www.manual-lib.com>

<http://www.404manual.com>

<http://www.luxmanual.com>

<http://aubethermostatmanual.com>

Golf course search by state

<http://golfingnear.com>

Email search by domain

<http://emailbydomain.com>

Auto manuals search

<http://auto.somanuals.com>

TV manuals search

<http://tv.somanuals.com>