

PRINTRONIX®

*MVP Series
User's Manual*

MVP Series
User's Manual

PRINTRONIX®

P/N 112301-001, Rev B

US and CANADA Radio Interference Note

Note: This device complies with Part 15 of the FCC Rules. Operation is subject to the following two conditions: (1) this device may not cause harmful interference, and (2) this device must accept any interference received, including interference that may cause undesired operation.

Properly shielded and grounded cables and connectors must be used in order to meet FCC emission limits. The manufacturer is not responsible for any radio or television interference caused by using other than recommended cables and connectors or by unauthorized changes or modifications to this equipment. Unauthorized changes or modifications could void the user's authority to operate the equipment.

The input/output (I/O) cable must be shielded for the printer to comply with FCC rules and regulations Part 15 governing the radiation limits for Class "A" equipment.

This Class A digital apparatus meets all requirements of the Canadian Interference-Causing Equipment Regulations.

Cet appareil numérique de la classe A respecte toutes les exigences du Règlement sur le matériel brouilleur du Canada.

WARNING

This is a Class A product. In a domestic environment this product may cause radio interference in which case the user may be required to take adequate measures.

Printronix, Inc. makes no representations or warranties of any kind regarding this material, including, but not limited to, implied warranties of merchantability and fitness for a particular purpose. Printronix, Inc. shall not be held responsible for errors contained herein or any omissions from this material or for any damages, whether direct, indirect, incidental or consequential, in connection with the furnishing, distribution, performance or use of this material. The information in this manual is subject to change without notice.

This document contains proprietary information protected by copyright. No part of this document may be reproduced, copied, translated or incorporated in any other material in any form or by any means, whether manual, graphic, electronic, mechanical or otherwise, without the prior written consent of Printronix, Inc.

All rights reserved. Revision B. March, 1996.

TRADEMARK ACKNOWLEDGMENTS

Printronix is a registered trademark of Printronix, Inc.

MVP is a registered trademark of Printronix, Inc.

IGP is a registered trademark of Printronix, Inc.

PRINTRONIX®

17500 Cartwright Road, P.O. Box 19559

Irvine, California 92713

Telephone (714) 863-1900 FAX (714) 660-8682

Technical Support (714) 221-2686

COPYRIGHT © 1991, 1996, PRINTRONIX, INC.

Table of Contents

1 Introduction

About This Manual	1-2
Introduction	1-4
Printer Features	1-4
MVP-Series Printers	1-5
L150 Printers	1-6
150B/L150B Printers	1-6
Optional Features	1-7
Character Formation	1-8
Line Matrix Printing	1-9
Print Rate	1-10
Plot Rate	1-11

2 Installation

Introduction	2-2
Power Requirements	2-3
Site Requirements	2-4
Installing the Printer	2-5
Assembling the Pedestal	2-5
Assembling the Paper Tray	2-8
Mounting the Printer onto the Pedestal	2-9
Attaching the Paper Tray	2-10
Table Top Mounting	2-11
Applying Power	2-12
Preliminary Testing	2-12

3 Operation

Introduction	3-2
Mechanical Controls	3-2
Power On-Off	3-3
Operator Panel Switches and Indicators	3-3
Second Function Switches	3-6
Loading Ribbon	3-8
Removing the Ribbon	3-10
Paper Guidelines	3-11
Paper Type and Thickness	3-11
Loading Paper	3-12
Removing Paper	3-15
Setting Top-of-Form	3-16
Setting Forms Length	3-17

4 Configuration

Introduction	4-2
Changing Configurations	4-3
MVP/L150	4-3
150B /L150B	4-4
Verifying Configurations	4-5
Configuration Options	4-6
Quick Reference Table for Configuration Options 20-61	4-7

5 Graphics

Introduction	5-2
Raster Plotting	5-2
Raster Plot Syntax	5-4
Print Modes for Raster Plots	5-5
High Resolution Raster Plot Syntax	5-6
Scaling Graphics	5-6
Exiting from Raster Plot	5-7
Bit Image Graphics	5-8
Characteristics of Bit Image Graphics	5-8
Plotting a Bit Image Pattern	5-10
Bit Image Density	5-11
Bit Image Programming Format	5-12
Bit Image Sample Program	5-13
Other Bit Image Features	5-14
P-Series Plot Mode	5-15
Plot Density	5-15
Plot Data Byte Format	5-16
Plot Data Line Format	5-18
Plotting Data	5-20
Exiting P-Series Plot Mode	5-22

6 EFVU

Introduction	6-2
Programming EVFU Memory	6-2
Start Load Code — 6Hex	6-2
Channel Assignment	6-3
End Load Code — 6F Hex	6-4
EVFU Command Codes	6-5
EVFU Programming Example	6-5
Troubleshooting for EVFU Programming	6-7
Using EVFU	6-8
EVFU/IGP Execute Form Mode	6-9
Relative Line Slewing	6-9
Clearing EVFU Memory	6-11

7 Programming

Introduction	7-2
Control Codes (Quick Reference Tables)	7-3
MVP/L150 Control Codes	7-4
150B/ L150B Control Codes	7-27

8 Interface

Introduction	8-2
Centronics and Dataproducts Interface Characteristics	8-2
Centronics Interface	8-3
Dataproducts Interface	8-5
Interface Configuration Options 60-99	8-8
Switching Interfaces	8-26

9 Routine Service and Diagnostics

Introduction	9-2
Cleaning Requirements	9-2
Before Cleaning	9-3
Cleaning the Printer	9-5
Moving the Printer	9-7
Reconnecting the Cables	9-8
Corrective Maintenance	9-9
Self-Tests	9-10
Self-Test Procedure	9-10
Self-Test Configuration	9-12

Appendices

Appendix A: Character Sets and Control Codes

Appendix B: Printer Diagnostics

Appendix C: Specifications, Accessories and Options

Index

1

Introduction

Chapter Contents

About This Manual	1-2
Introduction	1-4
Printer Features	1-4
MVP-Series Printers	1-5
L150 Printers	1-6
150B/L150B Printers	1-6
Optional Features	1-7
Character Formation	1-8
Line Matrix Printing	1-9
Print Rate	1-10
Plot Rate	1-11

About This Manual

This manual applies to the MVP-Series of *Printronix* printers; the standard MVP, L150, 150B and L150B. Explanations and descriptions that refer to standard MVP or MVP-Series printers apply to all four printers in the series.

Chapters that address configuring and programming issues distinguish between the MVP/L150 and 150B/L150B. This is due to the different software pertaining to each printer. In all other areas, the four printer are similar.

How to Locate Information

- Use the Table of Contents at the front of the manual.
- Use the Chapter Contents listed on the first page of each chapter.
- Use the Index at the back of the manual.

Warnings and Special Information

Read and comply with all information highlighted under special headings:

WARNING

Conditions that could harm you as well as damage the equipment.

CAUTION

Conditions that could damage the printer or related equipment.

IMPORTANT

Information vital to proper operation of the printer.

NOTE: Information affecting printer operation.

Switches, Keys, Indicators and Display Messages

Switches, indicators and switch positions on the printer are uppercase. For example: Press and release the RDY switch.

Messages that appear on the control panel display are printed in initial capital letters and set off with quotation marks (except for conjunctions, which are all lowercase). For example: "Save Config" appears on the message display.

Introduction

The MVP-Series printers are line matrix printers that provide high quality printing and graphics by printing at 200 lines-per-minute (lpm) and plotting at 18.7 lpm in five different print modes. They offer features such as dot matrix flexibility, plug-in PROMs that allow alternate character sets to substitute for the standard set and the capability of printing on a wide variety of multi-part forms, labels and other business forms.

All MVP-Series printers have a digital panel and switches that allow you to select and control internal functions, run self-tests, and configure the printer for selected responses to commands and data from the host computer.

Printer Features

The Standard MVP is a sophisticated printer that has a wide variety of printing capabilities. It provides standard features and functions that allow you to control and define printer output. Its counterpart, the L150, offers the Standard MVP features and functions along with additional features that allow for especially high quality print and graphics. The 150B and L150B not only offer all of the Standard MVP and L150 functions and features, but they are also designed to meet the specifications of industry bar code standards for the Department of Defense (LOGMARS), Auto Industry (AIAG), Health Industry (HIBC), and others.

MVP-Series Printers

All MVP printers offer these standard features:

- Alternate character sets
- Electronic Vertical Format Unit
- Elongated characters
- Test pattern printing
- Host mode control
- Plotting
- Slewing
- Underlining
- Accommodating a wide variety of forms, including card stock, adhesive backed forms for label applications, and one-part to six-part bond for reports.

In the normal operating mode, all MVP printers provide the following standard functions at the control panel:

- Placing the printer on-line or off-line
- Changing spacing selection
- Controlling paper advance
- Displaying the current printer operating mode (1-5)
- Displaying a status condition with a displayed fault code
- Displaying the selected line spacing

In the normal operating mode, all MVP printers provide the following standard functions from the host:

- Changing the print mode
- Changing the forms length
- Configuring the printer
- Running self-tests
- Configuring with a *Printronix* Intelligent Graphics Processor (IGP-20) to produce bar codes, labels, and business forms.

L150 Printers

In addition to the standard features and functions listed in “MVP Printers,” the L150 printers print approximately a 0.017 inch diameter dot that assures printed bar codes will meet demanding size and quality specifications. L150 printers also have various print modes that match dot density and resolution to specific bar code applications:

- MODE 2 prints text at a character pitch of 10 cpi for data processing applications.
- MODE 4 provides a plot density designed for bar codes such as Code 3/9, Interleaved 2/5, and Code 128. In addition, text can be printed at a character pitch of 12.1 cpi.
- MODE 5 provides a plot density designed for Universal Product Code (UPC) and European Article Numbering (EAN) bar codes. In addition, text can be printed at a character pitch of 13.3 cpi.

150B/L150B Printers

In addition to the standard features and functions listed in “MVP Printers,” the 150B/L150B printers offer a configuration lock and unlock feature. Special to the 150B and L150B is a raster dot matrix code configured in a character format, which allows multi-mode character printing. These dot matrix codes are accessed by an ASCII character code transmitted by the computer. The flexibility of the dot matrix code structure permits the configuration of a wide variety of characters and symbols for international languages and graphic applications. The 150B/ L150B multi-density graphics capabilities include plots, bar codes, graphs, block printing, and complex curves.

Optional Features

The following are some of the various optional features offered to extend the versatility of MVP-Series printers:

Special and Custom Character Sets

96 character ASCII; 64 character, OCR full width; EBCDIC; Block characters; and Custom characters.

Standard MVP Density Option

Permits a four percent increase in MVP vertical dot density.

Long Lines Interface

Enables operation with a Dataproducts 2230 or 2260, differential drive, balanced interface type controller. The interface can transfer up to 400,000 characters per second for distances up to 500 feet.

PI-3287 Printer Interface

Allows the L150 to emulate an IBM 3287 printer, and attaches to IBM 3274 or 3276 cluster controllers through Type A Interface. It may be used with or without IGP-20 option.

IGP-20

The IGP-20 makes it easy to define, store, and then print forms and labels in a single pass. Functions that can be performed with the IGP-20 are:

- On-line Forms Generation - boxes, corners, vertical and horizontal lines, logos and special form size print can be generated for a preprinted appearance.
- Variable Bar Codes - size, rotation, and bar code data fields are easy to define and print.
- Expanded characters - characters can be created up to 99 times larger than normal for labels, titles, and signs. The vertical and horizontal sizes of characters are controlled independently to create different appearances.
- Logos - expanded characters and reverse print can combine with graphics to create customized logos. Up to 16 logos may be stored, then called from a library for printing, either individually or in combination with the create forms mode.
- Compressed Print- allows up to 132 characters printed on one line of standard 8 1/2 inch wide paper.
- Reverse Print - allows printing reversed to white on black .

Character Formation

The MVP-Series printers generate characters by accumulating groups of dots in matrices. Dot impressions are made by an assembly of 17 hammers installed on an oscillating shuttle that impact the paper through a moving ink ribbon. Synchronized horizontal shuttle movement and vertical paper advancement produce overlapping dots that form solid characters (Figure 1-1).

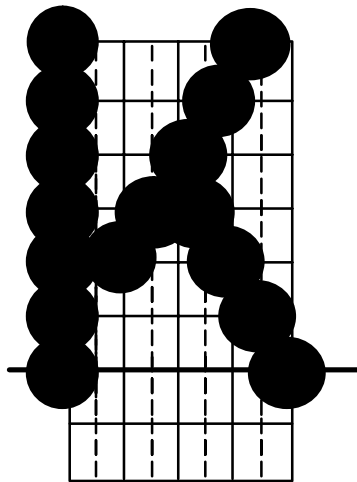

Figure 1-1. Typical Character Formation

Line Matrix Printing

Unlike moving-head serial dot matrix printers, the MVP-Series printers create graphics and characters by printing an entire dot row at one time. Dots are printed in both directions of shuttle travel, at a printer stroke length of .2" to print through two character positions. By printing a row of dots, dot matrix line printers achieve higher print duty cycles than moving head dot matrix (serial) printers.

During each sweep of the shuttle, hammers are activated to print dots at selected positions in that dot row. When the shuttle reaches the end of a sweep, it reverses direction, paper advances one dot row, and the hammers print the next consecutive row of dots.

After a line of characters is printed, hammer print action ceases while the paper advances to the first dot row of the next print line. The number of rows allowed for line separation depends on the line spacing selected.

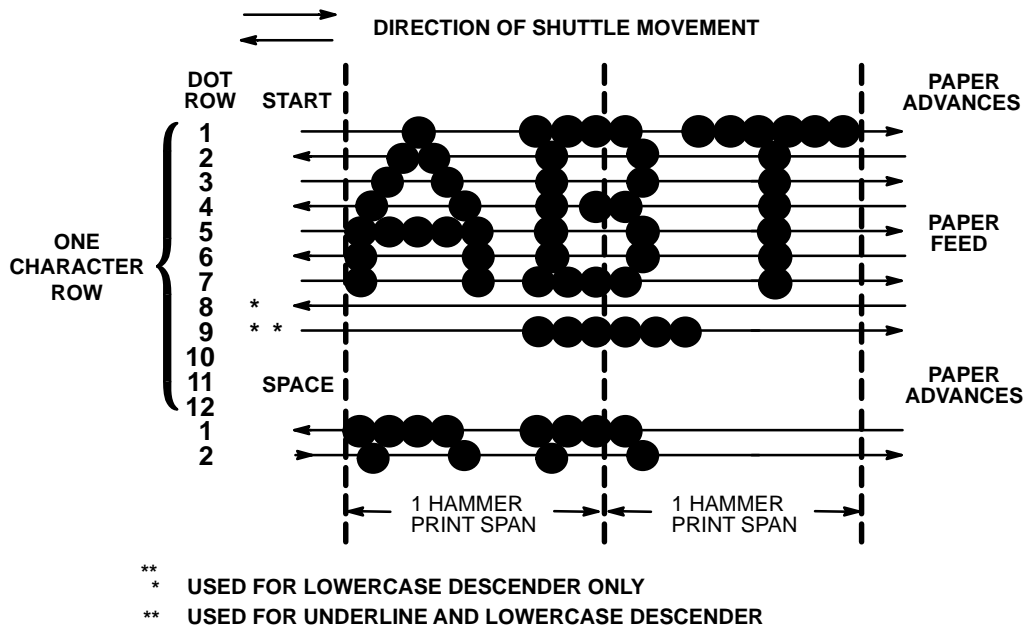

Figure 1-2. Line Matrix Printing

Print Rate

The print rate, in lines per minute (lpm), is a function of the number of dot rows required to produce the character line regardless of the number of characters in the line. For example, more dot rows are required to print lowercase characters with descenders; consequently, those characters take longer to print. Table 1–1 shows the print rate according to the type of character printed and print mode. Complete printing specifications are provided in Appendix C.

Table 1–1. Print Rate

Print Mode	Print Rate (lpm)			
	<i>Uppercase (only)</i>		<i>Upper/Lowercase</i>	
	MVP/L150	150B/L150B	MVP/L150	150B/L150B
Correspondence	80	80	62	62
Data Processing	150	150	120	120
High Speed	200	180	N/A	N/A

Plot Rate

The MVP-Series printers are capable of dot-addressable graphic plotting, as well as character printing. Based on the protocol selected either P-Series or Serial Matrix, you may select either Plot Mode or Bit Image Graphics respectively. The plot rate specifications apply to both P-Series and Serial Matrix types of graphic plotting. The bi-directional plot rate in inches per minute (ipm) is shown in Table 1-2 according to the dot density in dots per inch, (dpi). Complete plotting specifications are provided in Appendix C.

Table 1-2. Plot Rate

Density (dpi)	Plot Rate (ipm)		
	MVP	L150	150B/L150B
100 Horiz x 96 Vert (NLQ mode)	8.3	N/A	8.3
60 Horiz x 72 Vert (DP mode)	16.7	N/A	16.7
62.5 Horiz x 64 Vert (HS mode)	18.7	N/A	8.7
50 Horiz x 48 Vert (HSB mode)	25	13.8	27.8
100 Horiz x 72 Vert (HSC mode)	8.3	13.0	10.4

NOTE: Unidirectional plotting produces better print quality than bi-directional, and can be selected from the control panel; however, unidirectional plotting reduces the plot rate by half.

2 Installation

Chapter Contents

Introduction	2-2
Power Requirements	2-3
Site Requirements	2-4
Installing the Printer	2-5
Assembling the Pedestal	2-5
Assembling the Paper Tray	2-8
Mounting the Printer onto the Pedestal	2-9
Attaching the Paper Tray	2-10
Table Top Mounting	2-11
Applying Power	2-12
Preliminary Testing	2-12

Introduction

Be sure to read this chapter carefully before installing and operating the printer. Perform the procedures in the order presented.

CAUTION

The shipping restraints must be removed prior to operation to prevent damage to the printer. In addition, the shipping restraints must be installed whenever the printer or shuttle assembly is shipped or transported to prevent damage.

VORSICHT

Um Schaden am Drucker zu verhüten, vor Gebrauch die Verpackungseinsätze entfernen. Bei Versandt oder Transport des Druckers oder Pendelaufbaus, die Verpackungseinsätze swecks Schadensverhütung wieder installieren.

Power Requirements

CAUTION

MVP-Series printers employ a single phase, capacitive start shuttle motor. All models require 120 volts at 4 amps for a duration of 0.5 seconds at motor start-up. This is an important power requirement and is recommended to supply power from a separate AC circuit of 20 amps at 60 Hz.

VORSICHT

Die MVP Drucker benutzen einen ein-phasigen, kapazitive-startenden Pendelmotor. Die MVP Modelle benoetigen beim Anlassen 0,5 Sek. lang 25,4 A. Diese Stromanforderung ist wichtig und es wird empfohlen den Strom aus einem gesonderten AC-Stromanschluss von 20 A bei 60 Hz zu decken.

A label on the back of the printer near the power cord shows the voltage and frequency requirements. The printer must be connected to the specified power source, either 110, 220 or 240 volts at 50 to 60 Hz. Line voltage can vary by 10%. The printer automatically senses and adjusts itself to conform to the proper voltage. The printer contains primary circuit protection. Consult an electrician if printer operation affects local electrical lines.

Site Requirements

When selecting a printer location, consider interface requirements, power requirements, and environmental factors. Select a location that has the proper power source available and is within the maximum cable length specifications for interfacing with the host computer. The printer is designed to operate in a relatively dust free environment such as a computer room or business office with an ambient temperature of 5° to 40° C (41° to 104° F), and a relative humidity of 10% to 90%. The site selected for the printer must also allow air to circulate freely all around the printer. Finally, a minimum of three feet clearance behind the printer should be provided to allow air circulation and easy access to the paper stacking area.

CAUTION

The warranty may be voided if adequate printer ventilation is not provided. Overheating and serious damage to printer components can occur if the air vents at the sides and bottom of the printer are blocked.

VORSICHT

Die Gewährleistung könnte ungültig werden, wenn nicht genügend Druckerlüftung vorhanden ist. Überhitzung und schweren Schaden der Druckerkomponenten könnte vorkommen, wenn die Entlüftungsschlitze an den Seiten und unten am Drucker blockiert sind.

Installing the Printer

If you've ordered the *Printronix* pedestal mounting kit, follow the pedestal assembly procedures before installing the printer.

Assembling the Pedestal

To assemble the optional pedestal for pedestal model printers perform the following steps. A 5/16 inch nut driver and 5/32 inch hex wrench are required. Check for the following items in the pedestal ship kit before you begin assembly:

- 2 pedestal legs
- 1 modesty panel (large panel)
- 1 paper guide panel (small panel)
- 16 hex bolts
- 4 washers
- 1 paper tray

Prepare for Assembly

1. Unpack and lay the pedestal parts on the floor. The mounting holes on the legs should face up.

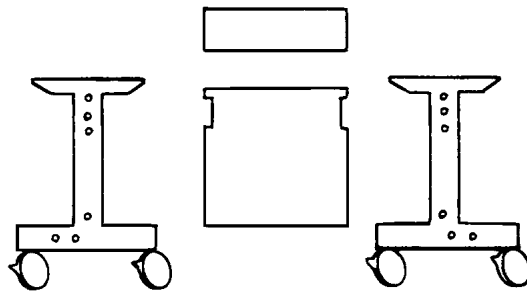

Assemble the Two Legs and Modesty Panel

2. Align the mounting holes of the modesty panel with the holes on the left leg as illustrated. Insert and lightly tighten bolts in the two side and bottom rear panel holes. Proceed with the right leg; align the mounting holes, insert and lightly tighten bolts.

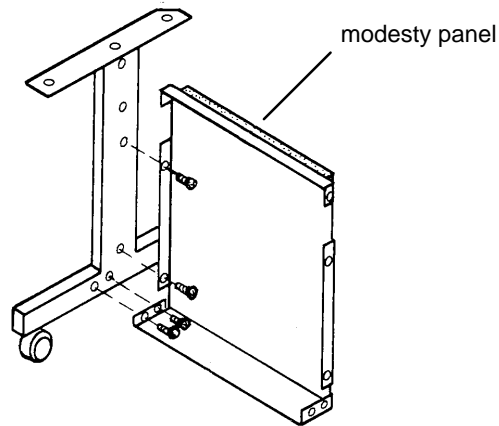

Add the Paper Guide Panel

3. Position the paper guide panel between the modesty panel and leg mounting holes, and align the mounting holes. The foam side of the panels should face each other, with the foam-covered lips facing up.

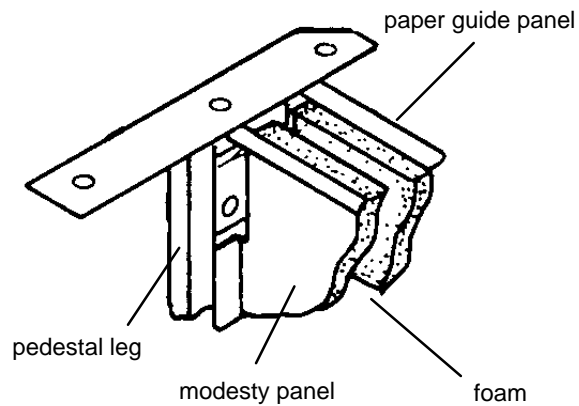

4. Insert and hand tighten bolts in the bottom left and right mounting holes in the paper guide panel. Align the top mounting holes on the modesty panel, paper guide panel, and left leg. Insert and hand tighten bolts through the top left and right mounting holes.

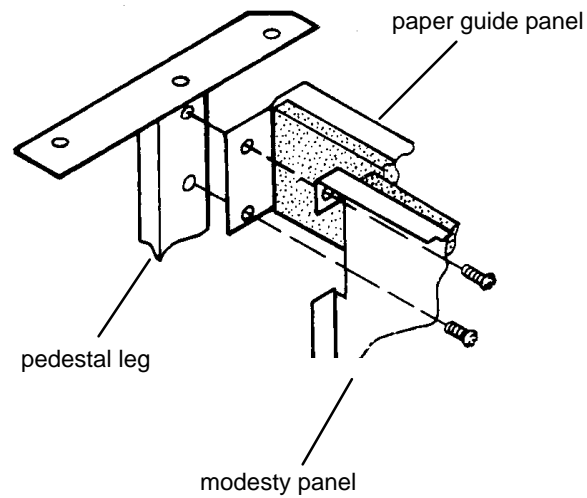

Adjust and Tighten

5. Firmly tighten all bolts.

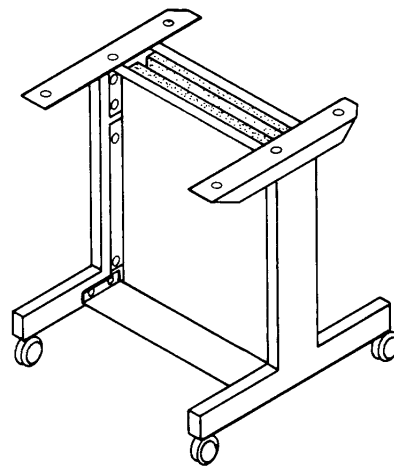

Assembling the Paper Tray

To assemble the paper tray refer to Figure 2–1, and perform the following steps.

1. Make sure the paper tray kit contains the following items:
 - 1 paper tray
 - 1 ground cable
 - 1 clamp
 - 1 screw
 - 1 nut
2. Snap the clamp over the bottom right rim of the paper tray.
3. Slip the screw through the clamp and position the ground cable ring onto the screw.
4. Thread the nut onto the screw and tighten.

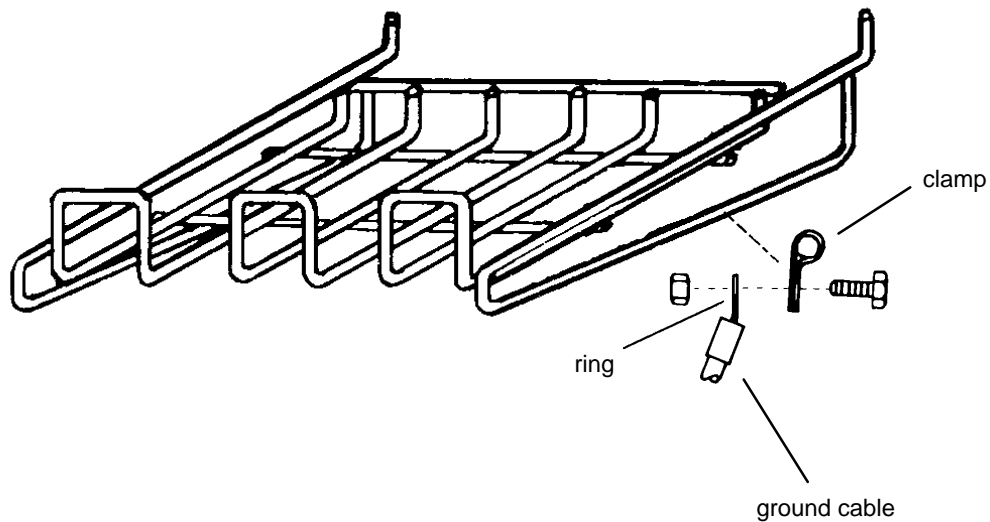

Figure 2–1. Assembling the Paper Tray

Mounting the Printer onto the Pedestal

To mount the printer onto the pedestal you need a 5/32 inch Allen wrench.

1. Set the printer on a stationary table or desk. Remove the four rubber feet from the printer by carefully sliding the printer over the edge of the table to access two feet. Use the Allen wrench to remove the feet. Turn the printer to the other side and remove the two remaining feet.
2. Carefully set the printer on the top of the pedestal. The front cover and the small panel should face the same direction.
3. Align the foot mounting holes with the four holes on the top of the pedestal. Place the washers on the four bolts and insert each through the pedestal base as illustrated. Firmly tighten the bolts.

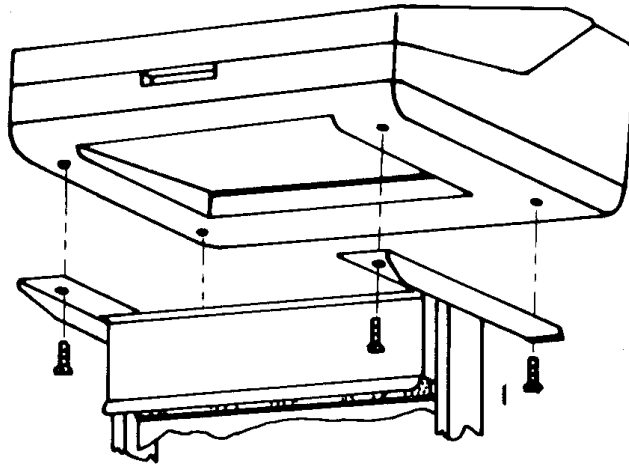
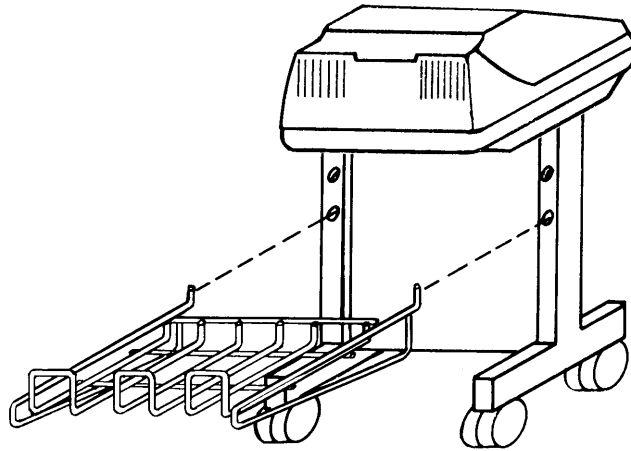

Figure 2–2. Mounting the Printer onto the Pedestal

Attaching the Paper Tray

1. Hook the paper tray into the pedestal mounting holes as illustrated. Use the upper holes when stacking small quantities of paper, and the lower holes when stacking larger quantities.



2. Push the ground cable connector onto the protruding metal tab located on the back of the printer, to the right of the power connector.

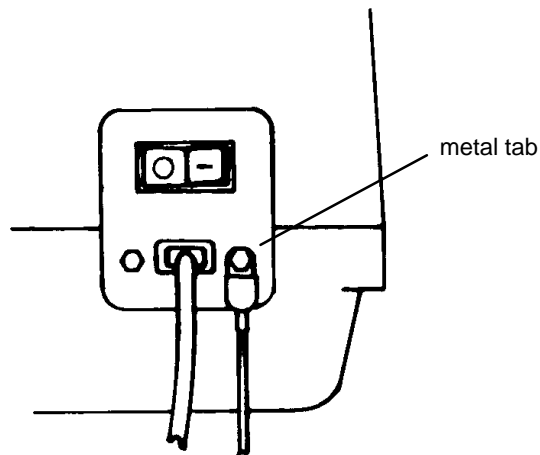

Table Top Mounting

The MVP-Series printers can be mounted on a sturdy table instead of the pedestal. However, the table must be designed or modified to accommodate the printer paper path and proper air ventilation.

1. Select a table sturdy enough to support the weight of the printer. If the table is not designed for a bottom feed paper path and proper air ventilation modify the table.
2. Make sure the four rubber feet are firmly attached to the base of the printer.
3. Position the printer on the table so the paper will feed from under the table, through the paper path slot, and up into the paper guide of the printer. The paper should pass through the slot with 1/2 inch clearance at both ends.
4. Assemble the paper tray (if used) according to the instructions in “Assembling the Paper Tray” on page 2–8, and position it behind the printer. Push the ground cable connector onto the protruding metal tab located on the back of the printer, to the right of the power connector.

Applying Power

After you properly install the printer, apply power by performing the following steps.

1. Check that the voltage shown on the printer identification label (located at the right rear of the printer) is the same as your power source. Voltage in North America is usually 120 volts/60 Hz, and printers sold in the United States are configured for power in that range. If your printer label reads V120 VAC and your power source is also 120 volts, plug the female end of the power cord into the male connector on the right rear of the printer. Plug the male end into the wall outlet.

WARNING

Operator hazard and printer damage is possible if the printer is connected to an incorrect power source.

2. Press the ON/OFF switch to ON. When you press the power switch to On, all indicators will light for approximately two seconds, and the RDY indicator remains lit to show the printer is on-line.

NOTE: The power On-Off switch is located at the rear of the printer and is marked “O” for power off, and “I” for power on.

3. After loading the ribbon and paper, conduct a self-test as described in the *Routine Service and Diagnostics* chapter.

Preliminary Testing

After you install and apply power to the printer, it is ready for preliminary testing. Refer to the “Self Tests” section in the *Routine Service and Diagnostics* chapter for the self-test instructions that apply to your specific type of MVP printer. Once the self-test has been completed, examine the print quality. The characters should be fully formed and of uniform density. If the test does not run or characters appear malformed, contact your authorized service representative.

3 Operation

Chapter Contents

Introduction	3-2
Mechanical Controls	3-2
Power On-Off	3-3
Operator Panel Switches and Indicators	3-3
Second Function Switches	3-6
Loading Ribbon	3-8
Removing the Ribbon	3-10
Paper Guidelines	3-11
Paper Type and Thickness	3-11
Loading Paper	3-12
Removing Paper	3-15
Setting Top-of-Form	3-16
Setting Forms Length	3-17

Introduction

This chapter briefly provides instructions and information on how to manipulate the mechanical controls, power switch, external function switches and internal function switches on MVP-Series printers.

Mechanical Controls

Become familiar with the mechanical controls for loading ribbon and paper, adjusting the paper position and the forms adjustment thickness lever, before you attempt to perform any procedures. Figure 3-1 is an interior view of an MVP with the shuttle cover removed to expose various mechanical controls, switches and indicators. Study this figure in relation to your printer to become familiar with the positions of the items specified.

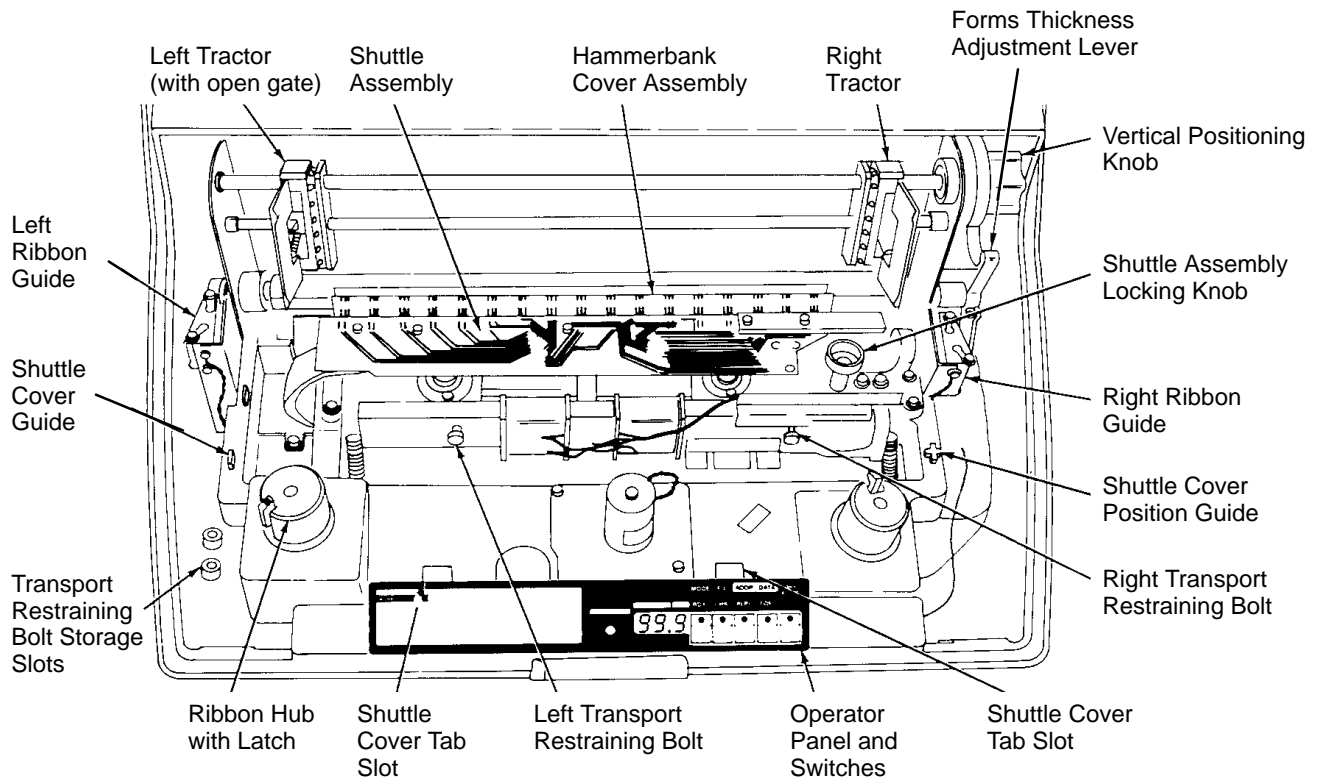

Figure 3-1. Printer Interior View (Shuttle Cover Removed)

Power On–Off

The power On–Off switch is located at the rear of the printer and is marked “O” for power off, and “I” for power on. When you press the power switch to “I”, all function indicators light for approximately two seconds, and the RDY indicator remains lit to show the printer is on–line.

Operator Panel Switches and Indicators

The operator panel has five switches with indicators, and a three–digit numerical display (Figure 3–2). The switches, labeled RDY, CHK, 8LPI and TOF, each have a small Light Emitting Diode (LED) indicator.

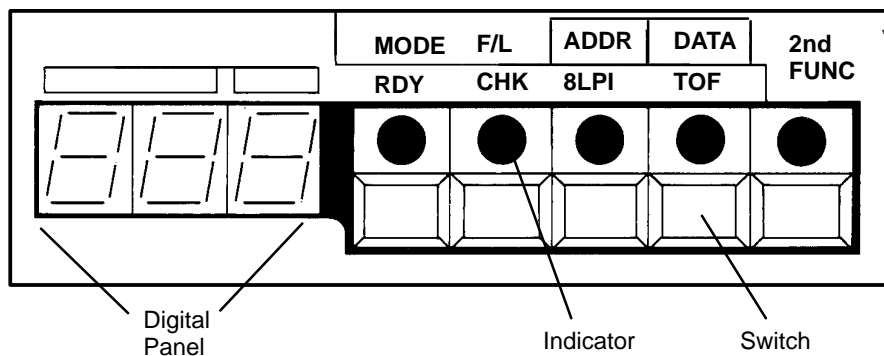

Figure 3–2. Operator Panel

NOTE: Printer will not operate if the CHK indicator is flashing.

When you turn the printer on, all four indicators light for approximately two seconds. However, the RDY indicator remains lit to show the printer is controlled by the host computer, on–line and ready to print.

You can *only* use the CHK, 8LPI and TOF switches when the printer is off–line. To take the printer off–line, press the RDY switch until the indicator flashes. The flashing indicator shows the printer is not controlled by the host computer, and is off–line. The following descriptions outline the switches in more detail.

RDY (Ready)

- Purpose** Indicates the printer is on-line and ready to print.
- Status** When the indicator is flashing, the printer is off-line.
When the indicator is lit, the printer is on-line.
- Action** To put the printer on-line; press and release, until the indicator is lit.
To take the printer off-line; press and release, until the indicator flashes.
- Result** When the printer is on-line, none of the other switches are active.
When the printer is off-line, use the front panel function keys.
- Other** If the printer is connected to the host, the host controls the printer when it is on-line. When the printer is off-line, the host no longer has control.

CHK (CHECK)

- Purpose** Indicates there is a problem or malfunction.
- Status** When the indicator is lit or flashing the printer is malfunctioning. A fault code indicating the type of problem will appear in the display. (Explanations of the codes are in Appendix B.)
- Action** If the indicator is flashing, check the fault code, fix the problem and reset the printer by pressing and releasing. If the indicator is lit, it is more than likely the printer needs to be serviced.
- Other** On occasion, you may be able to correct a steady indicator problem by pressing and releasing.

NOTE: The printer will not operate when the indicator is flashing or is lit. Therefore, you must take some action to restore the printer to working order.

8LPI (8 Lines Per Inch)

- Purpose** Allows for alternate spacing of either 8, 9 or 10 lines per inch. The default is 6 LPI.
- Status** When the indicator is lit, an alternate LPI is selected.
- Action** To select an alternate LPI, press and release until the desired LPI is selected.
- Other** Alternate spacing options are only available when the appropriate value has been assigned to printer configuration option 51. (See the *Configuration* chapter for more details on configuration options.) Line spacing may also be controlled by the host by using the appropriate command sequences. If an alternate LPI is selected, the 8LPI indicator will be lit, as if it were set from the panel.

TOF (Top-of-Form)

- Purpose** Advances the paper or adjusts top-of-form one line or one page at a time.
- Status** The indicator is always off, you must press to activate.
- Action** To move the paper one line; press and release very quickly. To move the paper one page or the to the top of the next form; press and hold for about one second.
- Other** Reset the TOF each time you load paper. Setting TOF after a paper load is described on page 3-16.

F/L (Form Length)

- Purpose** Allows the top of the page to begin in the same place on unusual length forms.
- Status** The indicator is always off.
- Action** Press to activate.
- Other** Paper that is a nonstandard length will need to have the new length set. You can select any length from 3 inches to 24 inches in one-half inch increments.

Second Function Switches

The operator panel has second function capabilities, and you can access them by pressing the 2nd FUNC key with either the MODE, F/L, ADDR or TOF switches. The printer configuration set at the factory will satisfy most printing requirements. However, when it becomes necessary to modify the way the printer responds to commands (printer reconfiguration) use the second function features. See page 4-4 for further information on reconfiguration.

The second function switches also allow you to change print modes, set forms length, top-of-form and print various self-test patterns. The following descriptions outline the switches in more detail.

2nd FUNC

- Purpose** Activates second operation of selected switches or returns to normal operation.
- Status** The indicator is always off, you must press to activate.
- Action** When the indicator is lit, the printer is in 2nd FUNC mode.
When the indicator is off, the printer is in the normal operation mode.
- Result** When the indicator is lit, only the MODE, F/L, ADDR and TOF can be used.

MODE

- Purpose** Selects print modes 1-5 (1-6 for 150B printers).
- Status** The indicator is always off, you must press to activate.
- Action** Press and release to display current mode.
To select desired print mode, press and release to cycle through print modes by 001.
- Result** After selecting print mode, press and release 2nd FUNC to print in the selected print mode.
- Other** The selected print mode will continuously display during printing. Refer to page 5-5 for detailed printer mode specifications.

F/L

- Purpose** Sets forms length from 3.0 to 24.0 inches in 0.5 increments. Verifies proper forms length when changing paper. See page 4–36 for proper configuration. See page 3–17 for the procedure to set the forms length.
- Status** The indicator is always off, you must press to activate.
- Action** Press and release to display current length.
To select desired forms length, press and release to advance by 0.5 increments. Press and hold for rapid advance. Display cycles from 03.0 to 24.0 inches.
- Result** After selecting print mode, press and release 2nd FUNC to print with the selected forms length.

ADDR

- Purpose** Selects and changes the configuration address in the numeric display (00 – 99).
- Status** The indicator is always off, you must press to activate.
- Action** Press and release to display current two–digit memory address code.
To select desired address, press and release to advance by 01 increments. Press and hold for rapid advance. Display cycles from 00 to 99.
- Result** After selecting the desired print test, press and release 2nd FUNC to print the selected table or test pattern.
- Other** See page 9–10 for the Self–Test Procedure.
Refer to page 4–3 for the Configuration Change Procedure.

DATA

- Purpose** Selects one of up to nine options (.0 – .9) for each configuration address.
- Status** The indicator is always off, you must press to activate.
- Action** Refer to page 9–10 for the Self–Test Procedure.
Refer to page 4–3 for the Configuration Change Procedure.

Loading Ribbon

The standard ribbon for MVP-Series printers is nylon fabric, one-inch by 60 yards, spool to spool, (*Printronix* part number 107675). The ribbon rewinds automatically to the supply side when installed, so either spool may be installed on either hub. The ribbon should be replaced when the print contrast is too low, or approximately after each box of standard size computer paper is used.

To load the ribbon, lift the printer cover and perform the following steps.

NOTE: The power does not need to be on when you load the ribbon. If it is, make sure the RDY light is flashing.

1. Move the forms thickness adjustment lever to the base of the printer as far as it will go. (If the power is on, the CHK indicator will flash when you move the lever.) The ribbon mask in back of the ruler will separate slightly.

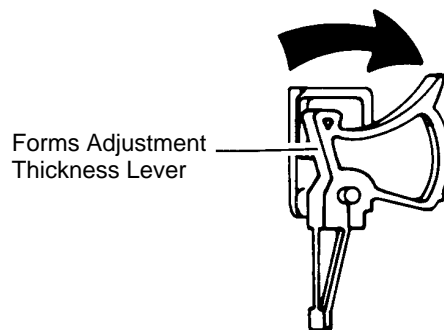

2. Place one spool of ribbon on a hub so the locking latch snaps into place and the ribbon unwinds toward the outside.

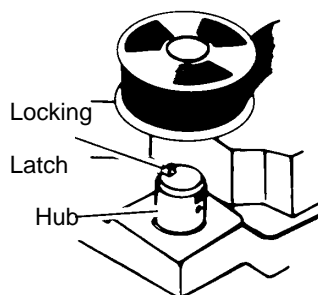

3. Pass the ribbon around the ribbon guides. Carefully place the ribbon between the ribbon mask and the ribbon guides, ensuring the ribbon is not twisted. Place the second spool of ribbon on the other hub so the locking latch snaps into place and the ribbon winds toward the inside. Adjust the tension by hand-winding the spool.

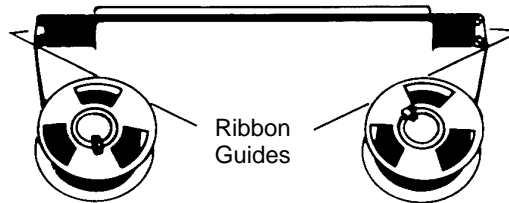

NOTE: A twisted ribbon will affect the print quality, shorten the ribbon life, and cause a paper or shuttle jam.

4. If paper is loaded, adjust the forms thickness adjustment lever for the appropriate position that is correct for the thickness of the paper.

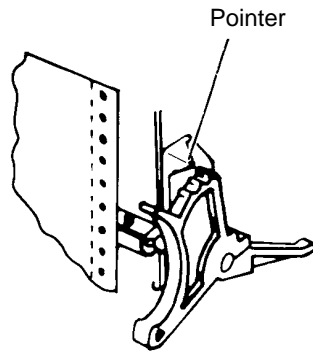

5. If the printer power remained on during ribbon loading, press the CHK switch. If there is no paper in the printer, the CHK indicator will continue to flash.

NOTE: Ribbon loading directions are also shown on the black plastic shuttle cover inside the printer.

Removing the Ribbon

To remove the ribbon refer to the illustrations in “Loading the Ribbon,” and perform the following steps.

1. Move the forms thickness adjustment lever to the base of the printer as far as it will go. (If the power is on, the CHK indicator will flash when you move the lever back.) The ribbon mask in back of the ruler will separate slightly.
2. Release the locking latch on one hub and lift the spool.
3. Carefully remove the ribbon from around the ribbon guides and out of the ribbon mask.
4. Remove the second spool from its hub.

Paper Guidelines

Paper used with the MVP-Series printers must meet the following guidelines:

- One-to-six parts, with or without carbon, continuous, and fan-folded
- Six-edge standard sprocket holes
- From 3 to 16 inches wide, including strips with the sprocket holes
- From 3 to 24 inches long
- Uniform thickness, including the sprocket hole edge strips, not to exceed 0.025 inches
- 15 to 100 lb. stock
- Interleaf attachment must not be metal or other hard material
- Labels on backing must be at least 1/16-inch from the fan-fold edge perforation and not have excess adhesive that can be pressed out when the label is printed
- Fan-fold forms should go through the printer without bunching or any distortion of the paper

Paper Type and Thickness

Paper type and thickness will affect print quality. Therefore, take both thickness and type under consideration when determining where to position the forms thickness adjustment lever. The three ridges on the lever are reference points for paper thickness that can be from one-to-six parts thick.

The forward (closed) lever position is for thinner paper. The back (open) lever position is for thicker paper. For example, the forms thickness adjustment lever should be positioned near the middle ridge when using three-part paper and usually at the last ridge for one-part paper.

NOTE: Always use full size computer paper (9¹/₂ x 11 inches or larger) when performing self-tests.

Loading Paper

To load paper lift the printer cover and perform the following steps. Read all of the instructions before loading the paper.

NOTE: The power does not need to be on when you load paper. If it is, make sure the RDY light is flashing.

1. Move the forms thickness adjustment lever to the base of the printer as far as it will go. (If the power is on, the CHK indicator will flash when the lever is moved or when the printer is out of paper.)

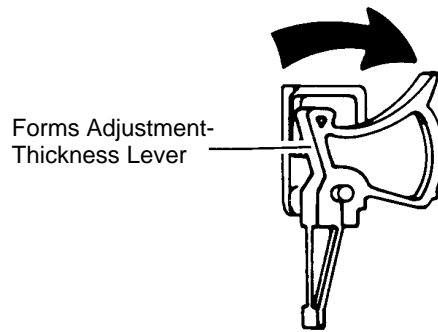

2. Pull the right tractor lever (the plastic lever to the right of the tractor) down to unlock it, then open both tractor gates. If you keep the left tractor stationary you will have less to adjust later.

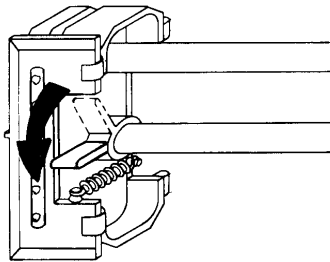

NOTE: The tractor levers on some printers must be pulled up to unlock and pulled down to lock.

3. Feed the paper into the slot from underneath if the printer is on a pedestal or from the front if the printer has a front feed attachment. Continue to feed the paper until it passes between the ribbon mask and the wide metal bar.

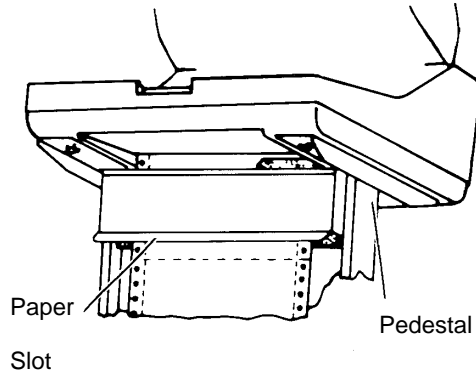

4. Load paper on the left tractor sprocket pins and close the tractor gate. Load paper on the right tractor sprocket pin. Make sure the paper is aligned horizontally (the correct holes are across from one another), and close the right tractor gate.

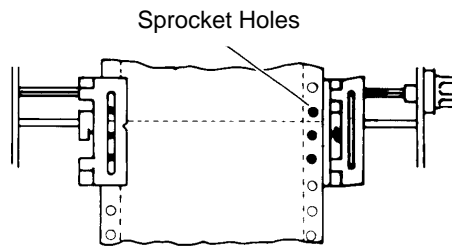

5. If the left tractor was kept stationary, proceed to step 7. If not, slide both tractors so that the edge of the paper lines up with the first mark on the printer's ruler, or where you want the left margin to print. Lock the left tractor lever (the black lever).

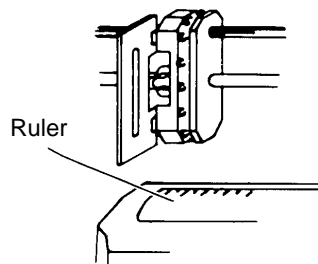

6. Adjust the right tractor so that the paper has just enough tension to be flat and taut without pulling. Pull the right tractor up to lock it.

NOTE: Too much or too little paper tension may distort the sprocket holes and cause problems in paper feeding or printing.

7. Advance the paper with the positioning knob so the paper will feed out of the opening between the raised cover and the top of the printer. Make sure the paper supply from the bottom will feed into the printer in a straight line.

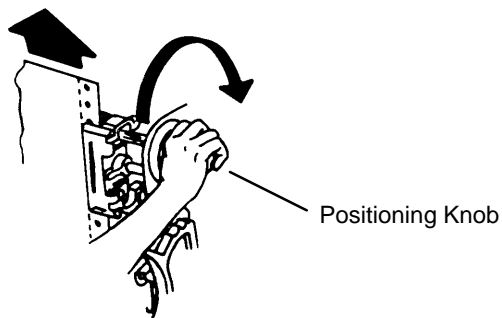

8. Adjust the forms thickness adjustment lever to the appropriate paper thickness. Refer to "Paper Type and Thickness" on page 3-11.

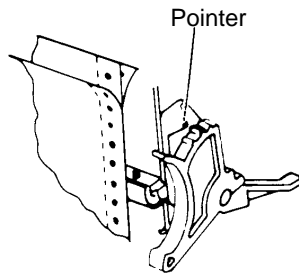

9. If the power was on while you loaded the paper, press the CHK switch. If the power was off, turn the power on and then press and release the RDY switch.
10. Set top-of-form (TOF). Top-of-form should be set each time the paper is loaded, refer to "Setting Top-of-Form" on page 3-16.

Removing Paper

To remove paper, follow these steps.

1. Tear off the paper at the first perforation just under the printer.

CAUTION

Pulling the paper down through the printer could damage the printing mechanisms.

2. Move the forms thickness adjustment lever to the base of the printer as far as it will go.
3. Open both tractor gates and lift the paper from the sprockets.
4. Pull the paper carefully upward and out of the printer.

Setting Top-of-Form

To set the top-of-form, perform the following steps.

1. Make sure the power is on and the RDY indicator is flashing.
2. Move the forms thickness adjustment lever to the fully open position.
3. The TOF alignment pointer allows you to set the first print line on the paper or form. Use the vertical positioning knob to align the top of the first print line with the TOF alignment pointers.

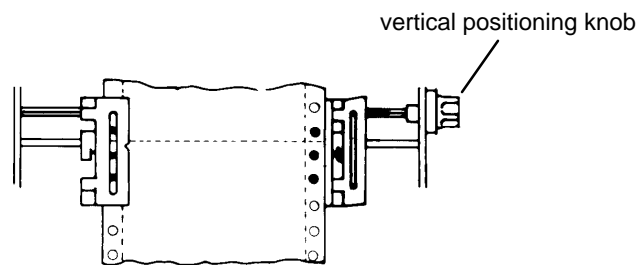

4. Adjust the forms thickness adjustment lever for the appropriate paper thickness.
5. Perform the following procedure on the operator's panel:
 - a. Press CHK to clear the "check" condition.
 - b. Press and hold the 2nd FUNC switch, then press and quickly release the TOF switch. Release the 2nd FUNC switch.
 - c. Press and hold the TOF switch for about one second; this action advances the paper to the top of the next form.
 - d. Press the RDY switch to set the printer ready for printing (on-line).

Setting Forms Length

To set the forms length, follow these steps.

1. Press and release the 2nd FUNC switch.
2. Press the F/L switch; the indicator will remain lit and the current forms length will display on the digital panel.
3. Press and quickly release the F/L switch to advance the number by 1/2 inch or press and hold the F/L switch until the number you want displays. After the number advances to 24 (24.0), it will automatically begin again at 3 (3.0).
4. If you want the printer ON-LINE, (ready to print) after setting the new forms length, press the 2nd FUNC switch to turn its indicator off. When the indicator goes off, the RDY indicator will flash. Press the RDY switch.

NOTE: If you want to return to your original forms length setting, reset to that length by following the directions above or turn the power off and the current forms length will reset automatically. Forms length displayed can be from either the host computer or the printer EAROM. Pressing the F/L switch will reset forms length to the EAROM value resulting in a forms length different than that generated by the host. Host forms length can be defined in either inches (1.0 to 22.0) or lines (001 to 127). Only forms length in inches can be specified from the printer front panel.

4 Configuration

Chapter Contents

Introduction	4-2
Changing Configurations	4-3
MVP/L150	4-3
150B /L150B	4-4
Verifying Configurations	4-5
Configuration Options	4-6
Quick Reference Table for Configuration Options 20-59	4-7

Introduction

Configuration refers to a set of option choices that define printer responses to operational commands. The printer responds to the particular set of commands it receives through either user-selected configuration choices or factory defaults that are functional unless you reconfigure a specific default.

NOTE: Configuration options must be provided for printer control firmware locations.

The printer can be configured by one of three methods:

- Factory default options that take effect when the printer is turned on, provided no other options have been set.
- Partial or total options set by you that take effect when the printer is turned on.
- Options entered by you after the printer is turned on.

The ADDR and DATA keys are used to select the available configurations and options. The ADDR key is used to select the configuration number, and the DATA key is used to select the option number.

The display at the left of the operator's panel shows a three-digit configuration number in the form of XX.Y, where:

- The two left digits (XX) represent the current configuration address from 00 to 99.
- The right digit (or third digit), (.Y), represents the option number from .0 to .9.

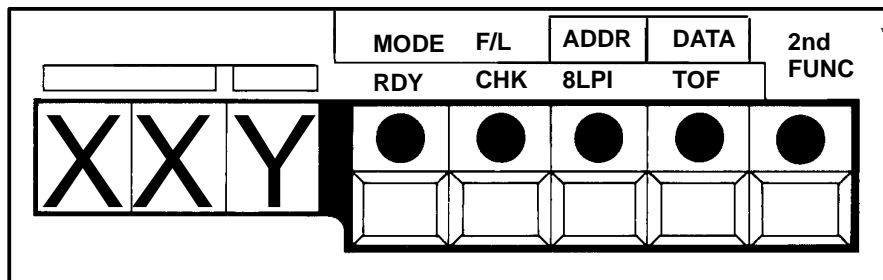

Figure 4-1. Operator's Control Panel

Changing Configurations

You can change configuration options by following the procedure particular to your MVP printer. For 150B and L150B printers, the configuration option procedures release the Configuration Safety Lockout, then locks it after changes are made.

MVP/L150

1. Press and release the RDY switch until the indicator flashes.
2. Press and release the 2nd FUNC switch until the indicator lights.
3. Press and release the ADDR key until the display shows a configuration option.

NOTE: Continue pressing and releasing ADDR until the desired configuration option displays. To view any of the values, press and hold ADDR. The displayed configuration option numbers cycle through 00 to 99.

4. First press and hold the DATA key, then press and release the MODE switch until the DATA indicator lights. Release DATA when the current configuration option and number displays.
5. Repeatedly press and release DATA until the desired configuration number displays.
6. Press ADDR to load the configuration and its number, and to advance to the next configuration option.
7. Press 2nd FUNC to exit .

NOTE: If values in configuration options 67–90 are changed, turn the printer off and on after all configurations are keyed in to reinitialize the serial version, USART

8. Repeat steps 1 thru 7 until all desired configurations are made.

150B/L150B

1. Press and release the RDY switch until the indicator flashes.
2. Press and release the 2nd FUNC switch until the indicator lights.
3. Press and hold the ADDR key until the display shows 16.0. Press and release the DATA key until the display reads 16.3.
4. Press and release 2nd FUNC until the RDY indicator flashes.

NOTE: At this point, the printer is off-line and ready to enable reconfiguration. Repeat steps 5 thru 9 until all desired configurations are made.

5. Press and release 2nd FUNC until the indicator lights, then press and release ADDR. The current configuration option and number will display.
6. Press and release ADDR to advance the configuration options by 01.

NOTE: Pressing and holding ADDR will advance the options continuously; release it when the desired configuration displays.

7. First press and hold DATA, then press and release MODE to select the third digit. When the digit is selected, release DATA.
8. Press and release DATA to advance the third digit by 01. Repeatedly press and release it until the desired configuration number displays.
9. Press and release 2nd FUNC to put the new option number into printer memory. Press and hold ADDR until the display reads 16.3
10. Press and release DATA until the display reads 16.4; this step locks out accidental reconfiguration.
11. Press and release 2nd FUNC to return the printer to off-line, and to lock in the new configuration.

Verifying Configurations

Verify the printer configuration to ensure that the appropriate response is received for a particular application. To verify a configuration:

1. Print out a configuration self-test using the Self Test Procedure on page 9–10 to set the configuration option to 00.1. (Make sure the printer is on-line.)
2. Compare the values of configuration options 20 through 99 with application requirements. Refer to the “Self-Tests” in Chapter 9 for a complete list of self-tests and instructions that apply to your type of MVP printer.
3. Use the explanations for configuration options 20 through 99 to determine the configuration settings selected.

NOTE: Use the explanations for configuration options 20 through 99 to determine the configuration settings selected. Explanations for standard MVP/L150 and 150B/L150B configuration options 20–59 begin on page 4–7. Configuration options 60 through 99 are discussed in the Interfaces chapter. Addresses 00–19 are test and service printout addresses.

4. Change the configuration options as necessary to meet application and interface requirements.

Configuration Options

After assembling and interfacing the printer, configuration changes are usually limited to configuration options 20 through 59. Options 60 through 99 are only changed when it is necessary to reconfigure the printer for a new interface. Configuration addresses 00 through 19 are print and service tests.

Table 4-1 is a sequential cross-reference of Standard MVP/L150 and 150B/L150B Configuration Options 20 through 59. Use the page numbers to access the option descriptions.

Table 4-1. Quick Reference Table for Configuration Options 20 – 59 1

Configuration Number	Printer Type	Configuration Option	Page #
20	MVP/L150	Host Mode Control Programming Standard	4-8
20	150B/L150B	Double Wide Print Operation (Expanded Print Select)	4-9
21	All	Vertical Dot Density	4-10
22	All	Insert automatic Line Feed in Data Stream	4-11
23	All	Automatic Line Feed on Carriage Return	4-12
24	All	Inhibit Lowercase/Underline and Translate Lowercase to Uppercase	4-13
25	All	Binary Count Slew	4-14
26	All	Printer On-line with Power On	4-15
27	All	Paper Out Delay	4-16
28	All	Underline	4-17
29	All	Delete	4-18
30	All	Print or Graphics Mode at Power On	4-19
31-41	MVP/L150	Control Code Assignments	4-20
31-41	150B/L150B	Control Code Assignments	4-25
42	All	Electronic Vertical Format Unit (EVFU)	4-27
43	All	Plotting Exit	4-28
44	All	Buffer Print with Top-of-Form (TOF)	4-29
45	150B/L150B	Mode 4	4-30
46	150B/L150B	EVFU Control with no PI	4-31
47	150B/L150B	SOH and ETX 21	4-32
48	150B/L150B	Character Per Inch in Mode 5	4-33
50	All	Page Perforation Skip	4-34
51	All	Lines Per Inch (LPI) Line Spacing	4-35
52	All	Forms Length at Printer Powerup	4-36
54	150B/L150B	Lines Per Inch-Line Spacing at Power Up	4-37
56	150B/L150B	Column Print Spacing	4-37
57	150B/L150B	Input Buffer Sizes	4-38
58	150B/L150B	ESC DC1 Sequence	4-38
59	150B/L150B	Version	4-38

NOTE: Options 60-99 are located in Chapter 8 beginning on page 8-8.

Option 20 — Host Mode Control Programming Standard

Discussion

Option 20.0 is used to store data that allows you to select the Host Mode Control. Option 20.1 allows up to 11 beginning characters (or headers) of control code sequences that are valid when encountered in the data stream; option 20.2 allows only one.

MVP/L150

Option Number	Display	Configuration Description
.0	20.0	Host Mode Control disabled (default)
.1	20.1	P-Series programming standard. (Control Code sequence for more changes appearing in data stream are edited per conditions attached to Configuration options 31 through 41.)
.2	20.2	ANSI programming standard. Control Code sequence for mode change must begin with ESC (1BH).

Option 20 — Double Wide Print Operation (Expanded Print Select)

Discussion

Option 20 makes it possible to print “double wide” characters. The term “double wide” is related in an inverse manner to pitch, and generally alludes to the width of alphanumeric characters just before the double wide feature is invoked.

150B/L150B

Option Number	Display	Configuration Description
.0	20.0	Double wide on per line basis only. Enables Mode 6. Initiated by either control code ESC SO or SO (see page 7–31). If the printer is operating at 10 pitch when the control code is executed, printer operation shifts to pitch 5. However, if the printer is operating at 16.7 pitch (Mode 5) when the control code is executed, printer operation changes to 10 pitch. If control code DC4 is received within that same line, it cancels any effect that ESC SO might have produced. See Note.
.1	20.1	Per character width doubling through control codes (Modes 1– 5) but excludes bit image characters. Default. Disables Mode 6. See Note

NOTE: When executed, any one of the following codes causes the pitch to change by one-half: (1) SO, (TEXT), LF produces a line of double wide characters; (2) SO, (TEXT), DC4, LF produces a line at whatever pitch is in effect at the time the line is received; or, (3) ESC W CHR\$ (1 or 49) will cause each succeeding line to have double wide characters.

Characters are produced at the reduced pitch until: the end of the line (printing takes place); a DC \$ is received; or, in the case of ESC W n, an ESC W CHR\$ (0 or 48) is received. Printing then resumes at the pitch rate in effect before the double wide feature was executed. For example, a line coded A (SO) B (DC4) C LF will be printed with “A” and “C” normal pitch and “B” double wide.

Option 21 — Vertical Dot Density

Discussion

Option 21 permits a four percent increase in vertical dot density. (The Density Option paper feed pulley must be installed for proper operation.)

MVP/L150

Option Number	Display	Configuration Description
.0	21.0	Enable standard P-Series compatible vertical dot density (default).
.1	21.1	Enable increased vertical dot density (with Density Option paper feed pulley installed).

150B/L150B

Option 21 must be set to 21.0.

Option 22 — Insert Automatic Line Feed in Data Stream

Discussion

Normally, Option 22 is disabled. When it is enabled, a line feed is automatically inserted into the data stream after the last character in a character line.

MVP/L150

Option Number	Display	Configuration Description
.0	22.0	Disable (default). No line feed inserted. Refer to the related table in the Programming chapter.
.1	22.1	Insert after 132nd character in Modes 001, 002 and 005 and after 165th character in Mode 003.
.2	22.2	Insert after 104th character in Modes 001, 002, and 004 and after 132nd character in Modes 003 and 005.
.3	22.3	Insert after 80th character in Modes 001 and 002, after 100th character in Mode 003 and after 132nd character in Mode 005.
.4	22.4	Insert after 80th character in Modes 001, 002, 003 and 005.

150B/L150B

Option Number	Display	Configuration Description																																				
.0	22.0	Automatic line feed inserted after 255 characters in all modes (default).																																				
.1	22.1	The table below shows where the automatic line feed is inserted, depending on which mode you are in.																																				
		<table border="1"> <thead> <tr> <th></th> <th>22.1*</th> <th>22.2*</th> <th>22.3*</th> <th>22.4*</th> <th>22.1**</th> </tr> </thead> <tbody> <tr> <td>Mode 1</td> <td>132</td> <td>104</td> <td>80</td> <td>80</td> <td>136</td> </tr> <tr> <td>Mode 2</td> <td>132</td> <td>104</td> <td>80</td> <td>80</td> <td>136</td> </tr> <tr> <td>Mode 3</td> <td>165</td> <td>132</td> <td>100</td> <td>80</td> <td>170</td> </tr> <tr> <td>Mode 4</td> <td>220</td> <td>132</td> <td>132</td> <td>80</td> <td>136</td> </tr> <tr> <td>Mode 5</td> <td>220</td> <td>176</td> <td>132</td> <td>80</td> <td>238</td> </tr> </tbody> </table>		22.1*	22.2*	22.3*	22.4*	22.1**	Mode 1	132	104	80	80	136	Mode 2	132	104	80	80	136	Mode 3	165	132	100	80	170	Mode 4	220	132	132	80	136	Mode 5	220	176	132	80	238
	22.1*	22.2*	22.3*	22.4*	22.1**																																	
Mode 1	132	104	80	80	136																																	
Mode 2	132	104	80	80	136																																	
Mode 3	165	132	100	80	170																																	
Mode 4	220	132	132	80	136																																	
Mode 5	220	176	132	80	238																																	

* = With Configuration Option 56.0

** = With Configuration Option 56.1

Option 23 — Automatic Line Feed on Carriage Return

Discussion

Carriage return (ODH) does not cause a line feed and the character line is not printed in the default configuration. The character line must be terminated with a Form Feed, Line Feed, or EVFU (Electronic Vertical Format Unit) command before it is printed. In other configurations, carriage return generates 1, 2, or 3 line feeds.

MVP/L150

Option Number	Display	Configuration Description
.0	23.0	CR = 0 line feed (default)
.1	23.1	CR = 1 line feed
.2	23.2	CR = 2 line feeds
.3	23.3	CR = 3 line feeds

NOTE: The Underline feature, Configuration Option 28, cannot be used if option 23.1–.3 is selected. These options set CR equal to one, two, or three line feeds, respectively, and cause the printer buffer contents to be printed before the underlines can be loaded into the buffer. The underlines are then printed one, two, or three lines below the desired position. A line terminator other than a carriage return (e.g, FF or EVFU terminator) must be used if 23.0 is not selected.

150B/L150B

Option Number	Display	Configuration Description
.0	23.0	No line feed on CR (default)
.1	23.1	CR = 1 line feed
.2	23.2	CR = 2 line feeds
.3	23.3	CR = 3 line feeds

NOTE: Use of option numbers .1–.3 requires that underlining be performed using either BS or ESC, -; n. See configuration option 28.1.

Option 24 — Inhibit Lowercase/Underline and Translate Lowercase to Uppercase

Discussion

Normally, underlines and lowercase characters are produced in the default configuration. When Option 24 is enabled, lowercase characters and underlines are inhibited for all modes.

MVP/L150

Option Number	Display	Configuration Description
.0	24.0	Disable (default). Provides underline and lowercase.
.1	24.1	Enable. Provides uppercase only and no underlines in all modes.

150B/L150B

Option 24 must be set to 24.0.

Option 25 — Binary Count Slew

MVP/L150

Option Number	Display	Configuration Description
.0	25.0	With Control Code 10H (binary count of 0) causes one line slew, 11H (binary count of 1) causes a two line slew, and each code increments by one up to Control Code 1FH (binary count of 15) which causes a 16 line slew.
.1	25.1	With set, the entire sequence is shifted by one so that Control Code 10H (binary count of 0) causes a 16 line slew instead of one, 11H causes a one line slew, and Control Code 1FH (binary count of 15) causes a 15 line slew.

NOTE: If Paper Instruction (PI) is enabled by configuration option 61.1, option 25 enables the user to shift the values for the line slew control codes by one. Note that a single PI (hex 00) command will slew a blank line.

150B/L150B

Option Number	Display	Configuration Description
.0	25.0	Slew 1 to 16 lines for line terminators PI (hex 00) thru PI (hex 0F).
.1	25.1	Slew 1 to 15 lines for line terminators PI (hex 00) thru PI (hex 0F). PI (hex 00) and PI (hex 01).

NOTE: Note that a single PI (hex00) command will slew a blank line. The distance between each P-Series plot dot row will be wrong if ESC or SOH '3'n or 'A'n is active. However, single PI (hex 00 – hex 0F) or EVFU slew commands will slew lines with vertical line spacing set with ESC or SOH '3'n or 'A'n commands. In addition to the ESC and SOH start header characters, the ETX character is also allowed (Hex 03).

Option 26 — Printer On-line with Power On

Discussion

Normally when the printer is turned on, the RDY switch must be pressed before the printer is on-line. When Option 26 is enabled, the printer is automatically on-line when the printer is turned on.

MVP/L150

Option Number	Display	Configuration Description
.0	26.0	Disable (default)
.1	26.1	Enable

150B/L150B

Option Number	Display	Configuration Description
.0	26.0	On-line with power on disabled (default)
.1	26.1	On-line with power on enabled.

Option 27 — Paper Out Delay

Discussion

Normally when the printer is out of paper, it will stop printing after the current line has been printed. Option 27 allows printing to continue until the next form feed (FF) is received or until the end of the page reaches the print hammers (typically an additional 1.1 inch of print).

MVP/L150

Option Number	Display	Configuration Description
.0	27.0	Print current line only (default).
.1	27.1	Print to end of form. Permits printing of data until either the next form feed character is received or an additional 1.1 inches (nominal) of printing or plotting has been performed, whichever comes first.

150B/L150B

Option Number	Display	Configuration Description
.0	27.0	Stop immediately when out of paper (default).
.1	27.1	Print additional 1.1 inches when out of paper.

Option 28 — Underline

Discussion

When 28.0 is selected and Option 23.0 is selected (CR=0 line feeds), characters can be underlined in the present character line.

MVP/L150

Option Number	Display	Configuration Description
.0	28.0	Enable underline (default).
.1	28.1	Disable underline.

NOTE: Configuration Options 23.1, 23.2, and 23.3 effectively disables underlining if CR is used as the line terminator. Underlines will still be printed; however, they will print 1, 2, or 3 lines below the text based on the CR option selected, 23.1, 23.2, or 23.3.

150B/L150B

Option Number	Display	Configuration Description
.0	28.0	Leading and trailing spaces are suppressed for automatic underline (default).
.1	28.1	Underline all blank spaces.

Option 29 — Delete Code 7F

Discussion

When a DEL (Delete) code is received, either a character from a font or a space may be printed depending on the configuration option selected.

MVP/L150

Option Number	Display	Configuration Description
.0	29.0	Enable space response to DEL code (default).
.1	29.1	Disable. Prints whatever character is in the font PROM at the DEL code address.

150B/L150B

Option Number	Display	Configuration Description
.0	29.0	DEL codes (7FH and FFH) are printable characters (default).
.1	29.1	DEL codes are destructive back spaces.
.2	29.2	DEL codes are ignored in data stream.

NOTE: This option is only available on printers equipped with V50. 59 DCU and MCU 20.25 (or later) firmware and primary font PROM 116043-001 or equivalent.

Option 30 — Print or Graphics Mode at Power On

MVP/L150

Option Number	Display	Configuration Description
.0	30.0	Enable Mode 002 – Data Processing (default).
.1	30.1	Enable Mode 001 – Corresponding/Word Processing (high resolution graphics)
.2	30.2	Enable Mode 003 – Compressed Print (medium resolution graphics)
.3	30.3	Enable Mode 004 – High Speed Plot (low resolution graphics)
.4	30.4	Enable Mode 005– Condensed Print (medium resolution graphics)
.5	30.5	Save current mode when the printer is turned off.

NOTE: For the L150, Mode 002 should be selected when the optional Intelligent Graphics Processor (IGP) board is being used to ensure correctly scaled graphics.

150B/L150B

Option Number	Display	Configuration Description
.0	30.0	Enable Mode 002 – Data Processing (default).
.1	30.1	Enable Mode 001 – Corresponding/Word Processing
.2	30.2	Enable Mode 003– Draft Mode
.3	30.3	Enable Mode 004 – High Speed Plot when Configuration Options 45.0 and 59.0 are enabled; Draft Mode when 45.1 and 59.0; 72.5 x 72 dpi Bar Code Mode when 59.1.
.4	30.4	Enable Mode 005– Condensed Print when when Configuration Option 59.0 is enabled; 80 x 72 dpi Bar Code Mode when 59.1.

Options 31–41 — Control Code Assignments

Discussion

Eleven configuration options are included in this group. Each option has ten configuration selections that can be assigned to an associated control code. When the control code assigned to a specific configuration option appears in the data stream, the printer will operate in response to the selection in that option.

For example, if Configuration Option 33.4 (8 lpi) is set, code 03 Hex (ETX) functions as Code 06 Hex (ACK), the code that causes the printer to shift from 6 lpi to 8 lpi.

Configuration options 31 through 41 can also be used with the P-Series programming standard for the Host Mode Control (refer to Configuration Option 20).

MVP/L150

Option Number	Display	Option 31 Control Code Assignment – 01 Hex
.0	31.0	Host Mode Control Header 01H (SOH) (default).
.1	31.1	Host Mode Control Header 01H (SOH).
.2	31.2	Even dot plot. Code 01H (SOH) performs the same as code 04H (EDT).
.3	31.3	Odd dot plot. Performs the same as 05H (ENQ).
.4	31.4	8 lpi. Performs the same as 06H (ACK).
.5	31.5	Elongated characters. Performs the same as 04H (EDT).
.6	31.6	Shift Out (alternate font select). Performs the same as 0EH (SO).
.7	31.7	Shift In (alternate font deselect). Performs the same as 0FH (SI).
.8	31.8	Ignored.
.9	31.9	Ignored.

Option Number	Display	Option 32 Control Code Assignment – 02 Hex
.0	32.0	Ignore (default).
.1	32.1	Host Mode Control Header. Code 02H (STX) performs the same as Code 01H (SOH).
.2	32.2	Even dot plot. Performs the same as 04H (EDT).
.3	32.3	Odd dot plot. Performs the same as 05H (ENQ).
.4	32.4	8 lpi. Performs the same as 06H (ACK).
.5	32.5	Elongated characters. Performs the same as 08H (BS).
.6	32.6	Shift Out (alternate font select). Performs the same as OEH (SO).
.7	32.7	Shift In (alternate font deselect). Performs the same as OFH (SI).
.8	32.8	Ignored.
.9	32.9	Ignored.
Option 33 Control Code Assignment – 03 Hex		
.0	33.0	Ignore (default).
.1	33.1	Host Mode Control Header. Code 03H (STX) performs the same as Code 01H (SOH).
.2	33.2	Even dot plot. Performs the same as 04H (EDT).
.3	33.3	Odd dot plot. Performs the same as 05H (ENQ).
.4	33.4	8 lpi. Performs the same as 06H (ACK).
.5	33.5	Elongated characters. Performs the same as 08H (BS).
.6	33.6	Shift Out (alternate font select). Performs the same as OEH (SO).
.7	33.7	Shift In (alternate font deselect). Performs the same as OFH (SI).
.8	33.8	Ignored.
.9	33.9	Ignored.
Option 34 Control Code Assignment – 04 Hex		
.0	34.0	Even dot plot (default).
.1	34.1	Host Mode Control Header. Code 04H (STX) performs the same as Code 01H (SOH).
.3	34.3	Odd dot plot. Performs the same as 05H (ENQ).
.4	34.4	8 lpi. Performs the same as 06H (ACK).
.5	34.5	Elongated characters. Performs the same as 08H (BS).
.6	34.6	Shift Out (alternate font select). Performs the same as OEH (SO).
.7	34.7	Shift In (alternate font deselect). Performs the same as OFH (SI).
.8	34.8	Ignored.
.9	34.9	Ignored.

Option Number	Display	Option 35 Control Code Assignment – 05 Hex
.0	35.0	Odd dot plot (default).
.1	35.1	Host Mode Control Header. Code 05H (ENQ) performs the same as Code 01H (SOH).
.2	35.2	Even dot plot. Performs the same as 04H (EDT).
.4	35.4	8 lpi. Performs the same as 06H (ACK).
.5	35.5	Elongated characters. Performs the same as 0EH (SO).
.6	35.6	Shift Out (alternate font select). Performs the same as OEH (SO).
.7	35.7	Shift In (alternate font deselect). Performs the same as OFH (SI).
.8	35.8	Ignored.
.9	35.9	Ignored.
Option 36 Control Code Assignment – 06 Hex		
.0	36.0	8 lpi (default)
.1	36.1	Host Mode Control Header. Code 06H (ACK) performs the same as Code 01H (SOH).
.2	36.2	Even dot plot. Performs the same as 04H (EDT).
.3	36.3	Odd dot plot. Performs the same as 05H (ENQ).
.5	36.5	Elongated characters. Performs the same as 08H (BS)
.6	36.6	Shift Out (alternate font select). Performs the same as OEH (SO).
.7	36.7	Shift In (alternate font deselect). Performs the same as OFH (SI).
.8	36.8	Ignored.
.9	36.9	Ignored.
Option 37 Control Code Assignment – 07 Hex		
.0	37.0	Ignore (default).
.1	37.1	Host Mode Control Header. Code 07H (BEL) performs the same as Code 01H (SOH).
.2	37.2	Even dot plot. Performs the same as 04H (EDT).
.3	37.3	Odd dot plot. Performs the same as 05H (ENQ).
.4	37.4	8 lpi. Performs the same as 06H (ACK).
.5	37.5	Elongated characters. Performs the same as 08H (BS).
.6	37.6	Shift Out (alternate font select). Performs the same as OEH (SO).
.7	37.7	Shift In (alternate font deselect). Performs the same as OFH (SI).
.8	37.8	Ignored.
.9	37.9	Ignored.

Option Number	Display	Option 38 Control Code Assignment – 08 Hex
.0	38.0	Elongated characters (default).
.1	38.1	Host Mode Control Header. Code 08H (BS) performs the same as Code 01H (SOH).
.2	38.2	Even dot plot. Performs the same as 04H (EDT)
.3	38.3	Odd dot plot. Performs the same as 05H (ENQ).
.4	38.4	8 lpi. Performs the same as 06H (ACK).
.6	38.6	Shift Out (alternate font select). Performs the same as OEH (SO).
.7	38.7	Shift In (alternate font deselect). Performs the same as OFH (SI).
.8	38.8	Ignored.
.9	38.9	Ignored.
Option 39 Control Code Assignment – 09 Hex		
.0	39.0	Ignore (default).
.1	39.1	Host mode control header. Code 09h (HT) performs the same as code 01H (SOH)
.2	39.2	Even dot plot. Performs the same as 04H (EDT).
.3	39.3	Odd dot plot. Performs the same as 05H (ENQ).
.4	39.4	8 lpi. Performs the same as 06H (ACK).
.5	39.5	Elongated characters. Performs the same as 08H (BS).
.6	39.6	Shift Out (alternate font select). Performs the same as OEH (SO).
.7	39.7	Shift In (alternate font deselect). Performs the same as OFH (SI).
.8	39.8	Ignored.
.9	39.9	Ignored.
Option 40 Control Code Assignment – 0E Hex		
.0	40.0	Shift Out (alternate font select) (default).
.1	40.1	Reserved.
.2	40.2	Even dot plot. Performs the same as 04H (EDT).
.3	40.3	Odd dot plot. Performs the same as 05H (ENQ).
.4	40.4	8 lpi. Performs the same as 06H (ACK).
.5	40.5	Elongated characters. Performs the same as 08H (BS).
.7	40.7	Shift In (alternate font deselect). Performs the same as OFH (SI).
.8	40.8	Ignored.
.9	40.9	Ignored.

Option Number	Display	Option 41 Control Code Assignment – 0F Hex
.0	41.0	Shift In (alternate font deselect). Performs the same as OFH (SI).
.1	41.1	Reserved. Host Mode Control Header. Code 0FH (SI) performs the same as Code 01H (SOH).
.2	41.2	Even dot plot. Performs the same as 04H (EDT).
.3	41.3	Odd dot plot. Performs the same as 05H (ENQ).
.4	41.4	8 lpi. Performs the same as 06H (ACK).
.5	41.5	Elongated characters. Performs the same as 08H (BS).
.6	41.6	Shift Out (alternate font select). Performs the same as OFH (SI).
.8	41.8	Ignored.
.9	41.9	Ignored.

Options 31–41 — Control Code Assignments

Discussion

Eleven configuration options are included in this group. When the control code assigned to a specific configuration option appears in the data stream, the printer will operate in response to the selection in that configuration option. For example, if Option 31.0 is selected and ESC ! appears in the data stream, the printer will switch to Text Dump Mode.

150B/L150B

Option Number	Display	Option 31 Control Code Assignment – 01 Hex
.0	31.0	Escape (ESC or SOH) sequences: ESC ! for Text Dump Mode, ESC P for Mode 1, and ESC R for Mode 2. (default)
.1	31.1	Escape (ESC or SOH) sequences: ESC ! for master print mode, ESC P for ignored, and ESC R for ignored.
Option 32 * Control Code Assignment – Cedilla Character Select		
.0	32.0	Extended character address 128 produces a space.
.1	32.1	Extended character address 128 produces the Cedilla character (Default). * This configuration is available only on printers equipped with V50.59 DCU, MCU 20.25 (or later) firmware, and primary font PROM 116043–001 or equivalent.
Option 33 Control Code Assignment		
.0	33.0	Slash zero disable (default).
.1	33.1	Slash zero enable.
Option 34 Control Code Assignment – Alternate Printronix Plot Control		
.0	34.0	Enable ESC Y, even dot centers. (default)
.1	34.1	Ignore ESC Y.
Option 35 Control Code Assignment – Alternate Printronix Plot Control		
.0	35.0	Enable ESC Z, odd dot centers (default).
.1	35.1	Ignore ESC Z.

Option Number	Display	Option 36 Control Code Assignment – Mode 1 Select
.0	36.0	Enable ESC P = Mode 1 (default) (ESC n if configuration 31.1)
.1	36.1	Ignore ESC P.
Option 37 Control Code Assignment – Mode 2 Select		
.0	37.0	Enable ESC R = Mode 2 (default) (ESC r if configuration 31.1)
.1	37.1	Ignore ESC R.
Option 38 Control Code Assignment – Double High Select		
.0	38.0	Enable ESC I = Double High (default) (ESC h if configuration 31.1)
.1	38.1	Ignore ESC I.
Option 39 Control Code Assignment – Mode 3 Select		
.0	39.0	Enable ESC V = Mode 3 (default)
.1	39.1	Ignore ESC V.
Option 40 Control Code Assignments — 03, 04H, 05H, 06H, 15H		
.0	40.0	Codes 03H, 04H, 05H, 06H and 15H are control data (default).
.1	40.1	Codes 03H, 04H, 05H, 06H and 15H are printable characters when ESC6 is enabled.
Option 41 Control Code Assignments — 80H – 9FH		
.0	41.0	Codes 80H – 9FH are control codes – affected by ESC 6 (default).
.1	41.1	Codes 80H – 9FH are printable characters – not affected by ESC 7.

Option 42 — Electronic Vertical Format Unit (EVFU) Control

Discussion

The EVFU is normally fully enabled with Option 61 set to 61.0. When Option 61 is set to 61.1, Paper Instruction (PI) may be used to disable Paper Slew.

MVP/L150

Option Number	Display	Configuration Description
.0	42.0	Enable EVFU control (default).
.1	42.1	Disable EVFU using ASCII Control Code. PI EVFU control remains enabled.
.2	42.2	Disable EVFU and interpret 10H through 1FH as printables (requires special font PROM). PI control of EVFU remains enabled.

NOTE: 42.0 requires selection of Configuration Option 61.0; 42.1 and 42.2 require selection of Configuration Option 61.1.

150B/L150B

Option Number	Display	Configuration Description
.0	42.0	Enable EVFU control (default).
.1	42.1	Disable Non-PI EVFU control; PI EVFU remains functional (see Configuration Option 46).

Option 43 — Plotting Exit

Discussion

Normally, changing the printer from plotting to character printing requires an extra line feed that will reset the dot row counter to zero and prevent the upper part of the characters from possibly being truncated. Option 43 can be configured to automatically include the line feed without being sent from the host computer.

MVP/L150

Option Number	Display	Configuration Description
.0	43.0	Single line terminator moves print head to next dot row. Additional line terminator moves print head to top of next character line and maintains line registration within the page (default).
.1	43.1	Line terminator moves print head to top of next character dot row. No extra line terminator is needed to avoid character truncation.

150B/L150B

Option Number	Display	Configuration Description
.0	43.0	Exit plot mode to top of character with extra line feed (default).
.1	43.1	Exit plot mode to top of character with no extra line feed.

Option 44 — Buffer Print with Top-of-Form (TOF)

MVP/L150

Option Number	Display	Configuration Description
.0	44.0	Enable printing of buffer contents when printer is off-line and TOF switch is pressed.
.1	44.1	Disable off-line buffer printing.

150B/L150B

Option Number	Display	Configuration Description
.0	44.0	Enable printing of last line of buffer contents when printer is off-line and TOF switch is pressed. (default)
.1	44.1	Disable off-line last line buffer flush.

Option 45 — Mode 4

150B/L150B

Option Number	Display	Configuration Description
.0	45.0	(Mode 4) High Speed Plot Mode with Configuration Option 59.0 enabled. (default)
.1	45.1	(Mode 4) Draft Mode with 59.0

NOTE: Configuration Option 46 is used to reconcile use of EVFU Codes for Epson.

Option 46 — EVFU Control with no PI

150B/L150B

Option Number	Display	Configuration Description
.0	46.0	Disable EVFU control with no PI and control codes: SO for double wide, SI for mode 5 print, and BS (OEH, OFH, and 08H) for non-destructive backspace. (default) Configuration Operation 42.x is ignored but PI EVFU remains functional (61.1 set).
.1	46.1	Enable EVFU control with no PI and control codes: SO for alternate font, SI for deselect alternate font, and BS (OEH, OFH, and 08H) for elongated print.
.2	46.2	Same as 46.1 setting with the exception of the interpretation of the ESC code [1BH]. ESC cannot be used to initiate an escape sequence; instead use SOH code [01H] as an alternative. All control codes 10H – 1FH, including DC2, DC4 and CAN, can be used as EVFU channel commands.
.3	46.3	Same as 46.0 except BS (08H) is used to turn one-line vertical elongated ON.

NOTE: 46.1 is effected by Control Code 42 and Control Codes 10H – 1FH can be used as EVFU control commands (except for ESC code [1BH] that is part of an escape sequence and codes DC 2 [12H], DC4 [14H], and CAN [18H]).

Option 47 — SOH and ETX

150B/L150B

Option Number	Display	Configuration Description
.0	47.0	SOH (01 Hex) and ETX (03 Hex) and ESC (01, 03 and 1B Hex) characters can all be used to initiate an EPSON like command sequence.
.1	47.1	SOH (01 Hex) and ESC (01, and 1B Hex) can be used to initiate an EPSON like command sequence.
.2	47.2	ESC used to initiate an EPSON like command sequence. Both SOH and ETX characters are ignored.
.3	47.3	ETX and ESC (01, and 1B Hex) can be used to initiate an EPSON like command sequence.

NOTE: 47.4 through 47.9 are the same as 47.2. The EPSON like command sequence can not be initiated if 47.2, or 47.4–9 is used in conjunction with the Configuration Option 46.2 (the ESC character can be used as an EVFU command).

Option 48 — Characters Per Inch in Mode 5

150B

Option Number	Display	Configuration Description
.0	48.0	Mode 5 (Compressed Print Mode) prints at 100 dpi, at 16.7 cpi. (default) The maximum line length is 220 characters per line when Configuration Option 22.1 is enabled.
.1	48.1	Mode 5 (Compressed Print Mode) prints at 90 dpi, at 15 cpi. The maximum line length is 198 characters per line Configuration Option 22.1 is enabled.

NOTE: Power does not have to be cycled when this option is changed (from 48.0 to 48.1 and vice versa). Once changed, the selected pitch for the character mode printing will remain in effect (even if power is cycled) until a different option is selected again.

Option 50 — Page Perforation Skip

Discussion

Use this option to avoid printing over page perforations. Option 50 allows the bottom of the current page and the top of the next page to remain blank for a variable vertical distance ranging from 1/2 inch to 1 inch. Perforation skip is disabled by selecting Option 50.1 and is automatically disabled when the EVFU is active regardless of Option 50 setting.

MVP/L150

Option Number	Display	Configuration Description
.0	50.0	Enable 1/2 inch skip over perforation.
.1	50.1	Disable perforation skip (default).
.2	50.2	Enable 2/3-inch skip.
.3	50.3	Enable 5/6-inch skip.
.4	50.4	Enable 1 inch skip. This function is always disabled when EVFU memory is loaded.

150B/L150B

Option Number	Display	Configuration Description
.0	50.0	Enable 1/2 inch skip over perforation.
.1	50.1	Disable perforation skip. (default)
.2	50.2	Enable 2/3-inch skip over perforation.
.3	50.3	Enable 5/6-inch skip over perforation.
.4	50.4	Enable 1 inch skip over perforation. This function is always disabled when EVFU memory is loaded.

Option 51 — Lines Per Inch (lpi) Line Spacing

Discussion

Normally, the printer offers 6 lpi and 8 lpi spacing for modes 001, 002, 003, and 005. Option 51 may be configured to change the 8 lpi spacing to 9 lpi or 10 lpi spacing for Modes 002 and 003.

MVP/L150

Option Number	Display	Configuration Description
.0	51.0	Enable 6 and 8 lines per inch (default).
.1	51.1	Enable 6 and 9 lines per inch.
.2	51.2	Enable 6 and 10 lines per inch.

150B/L150B

Option Number	Display	Configuration Description
.0	51.0	Enable 6 and 8 lines per inch (default).
.1	51.1	Enable 6 and 9 lines per inch.
.2	51.2	Enable 6 and 10 lines per inch. 8, 9, or 10 lines per inch are valid in all modes and can be controlled by an external host or by toggling the front panel 8LPI switch.

Option 52 — Forms Length at Printer Power Up

Discussion

Forms length can be set to one of seven selectable lengths including the default 11 inches. With Option 52 set to 52.7, any forms length between 3 inches and 24 inches (in 1/2-inch increments) can be selected with the Forms Length (F/L) switch.

MVP/L150

Option Number	Display	Configuration Description
.0	52.0	Enable 11 inch form (default).
.1	52.1	Enable 3.5-inch form.
.2	52.2	Enable 5.5-inch form.
.3	52.3	Enable 8-inch form.
.4	52.4	Enable 8.5-inch form.
.5	52.5	Enable 12-inches form.
.6	52.6	Enable 14-inch form.
.7	52.7	Enable F/L switch setting; F/L switch retained when power is cycled to the printer.

NOTE: Forms length selection is disabled when the EVFU is active and requires that printer power be cycled to set reconfiguration.

150B/L150B

Option Number	Display	Configuration Description
.0	52.0	Enable 11 inch form (default).
.1	52.1	Enable 3.5-inch form.
.2	52.2	Enable 5.5-inch form.
.3	52.3	Enable 8-inch form.
.4	52.4	Enable 8.5-inch form.
.5	52.5	Enable 12-inches form.
.6	52.6	Enable 14-inch form.
.7	52.7	Enable F/L switch setting.

NOTE: Forms length selection is disabled when the EVFU is active and requires that printer power be cycled to set reconfiguration.

Option 54 — Line Spacing at Power up

150B

Option Number	Display	Configuration Description
.0	54.0	6 lpi at Power up
.1	54.1	8 lpi at Power up
.2	54.2	10 lpi at Power up

NOTE: Power must be cycled when changing option 54 from .0 to .1.
Toggling the LPI switch after powerup will reset the printer to 6LPI.

Option 56 — Column Print Spacing

150B

Option Number	Display	Configuration Description
.0	56.0	132 column print enable (mode 5 = 16.7 cpi) (default).
.1	56.1	136 column print enable with the use of MCU 20.25 and up (mode 5 = 17.5 characters per inch horizontally).

Option 57 — Input Buffer Size

150B

Option Number	Display	Configuration Description
.0	57.0	Uses all available user memory for input buffer. (default)
.1	57.1	Input buffer size is 2 lines (264 characters).

NOTE: Power must be cycled when Configuration Option 57 is selected (from 57.0 to 57.1 and vice versa).

Option 58 — ESC DC1 Sequence

150B

Option Number	Display	Configuration Description
.0	58.0	ESC DC1 sequence is ignored (default)
.1	58.1	ESC DC1 sequence allowed (SCOPE line spacing n/144 inch). Note that 58.1 will reduce the input buffer size available. (See <ESC> or <SOH> CHR\$(17).)

Option 59 — Version

150B

Option Number	Display	Configuration Description
.0	59.0	Standard 150B version (default)
.1	59.1	150B version for L150 board (proper MCU LM .03 or later is required for correct operation). Modes 4 and 5 are high density bar code modes.

NOTE: For options 60 thru 99 refer to page 8–8.

5 Graphics

Chapter Contents

Introduction	5-2
Raster Plotting	5-2
Raster Plot Syntax	5-4
Print Modes for Raster Plots	5-5
High Resolution Raster Plot Syntax	5-6
Scaling Graphics	5-6
Exiting from Raster Plot	5-7
Bit Image Graphics	5-8
Characteristics of Bit Image Graphics	5-8
Plotting a Bit Image Pattern	5-10
Bit Image Density	5-11
Bit Image Programming Format	5-12
Bit Image Sample Program	5-13
Other Bit Image Features	5-14
P-Series Plot Mode	5-15
Plot Density	5-15
Plot Data Byte Format	5-16
Plot Data Line Format	5-18
Plotting Data	5-20
Exiting P-Series Plot Mode	5-22

Introduction

MVP-Series printers can produce bit image graphics in two modes: Raster Plot Mode and Bit Image Plot Mode. Both outputs are printed a dot row at a time, from top to bottom. The major difference between the two methods is the way the software manipulates the received data before output.

Raster plotting prints horizontal dot patterns corresponding to stored ASCII character code true or 1 bits. In bit image plotting, the stored code prints in vertical dot patterns because the print wires are arranged vertically.

P-Series compatible Odd/Even Dot Plot mode is only available in P-Series printer protocol. Since plot mode can address and print any individual dot position, it is possible to produce a variety of graphics, including bar codes, complex curve graphs, pie and bar charts, block characters, or halftones.

To initiate special plotting features use the appropriate control sequences described in following sections. Some control sequences require that the software contain configuration options, coordinated with specific control codes, before they can provide the desired printer output.

Raster Plotting

Raster plot data is sent to the printer as “printable” ASCII characters. Each printable ASCII character has seven-bit binary code associated with it. There are 96 printable ASCII characters (see Table 5-1), starting with SP (space) decimal code 32, through DEL (delete) decimal code 127. Included in the set are the ten digits (0-9), the upper and lower case alphabet (A-Z and a-z) and the various punctuation and other characters normally available on a standard keyboard.

Dot patterns obtained using the raster plotting feature correspond to the least significant six bits of each seven-bit code. That is, a dot is typed for every bit set (every “1”) in the ASCII code, except the seventh, or most significant bit. The dot pattern progresses from left to right with the leftmost dot set by the least significant bit (LSB).

Table 5-1. ASCII Dot Patterns

BINARY	OCT	DEC	HEX	ASCII	2 4 6 8 10 12 1 3 5 7 9 11	BINARY	OCT	DEC	HEX	ASCII	2 4 6 8 10 12 1 3 5 7 9 11	BINARY	OCT	DEC	HEX	ASCII	2 4 6 8 10 12 1 3 5 7 9 11
0100000	040	32	20	Space	●●●●●●●●	1000000	100	64	40	@	●●●●●●●●	1100000	140	96	60	,	●●●●●●●●
0100001	041	33	21	!	●●●●●●●●	1000001	101	65	41	A	●●●●●●●●	1100001	141	97	61	a	●●●●●●●●
0100010	042	34	22	”	●●●●●●●●	1000010	102	66	42	B	●●●●●●●●	1100010	142	98	62	b	●●●●●●●●
0100011	043	35	23	#	●●●●●●●●	1000011	103	67	43	C	●●●●●●●●	1100011	143	99	63	c	●●●●●●●●
0100100	044	36	24	\$	●●●●●●●●	1000100	104	68	44	D	●●●●●●●●	1100100	144	100	64	d	●●●●●●●●
0100101	045	37	25	%	●●●●●●●●	1000101	105	69	45	E	●●●●●●●●	1100101	145	101	65	e	●●●●●●●●
0100110	046	38	26	&	●●●●●●●●	1000110	106	70	46	F	●●●●●●●●	1100110	146	102	66	f	●●●●●●●●
0100111	047	39	27	,	●●●●●●●●	1000111	107	71	47	G	●●●●●●●●	1100111	147	103	67	g	●●●●●●●●
0101000	050	40	28	(●●●●●●●●	1001000	110	72	48	H	●●●●●●●●	1101000	150	104	68	h	●●●●●●●●
0101001	051	41	29)	●●●●●●●●	1001001	111	73	49	I	●●●●●●●●	1101001	151	105	69	i	●●●●●●●●
0101010	052	42	2A	*	●●●●●●●●	1001010	112	74	4A	J	●●●●●●●●	1101010	152	106	6A	j	●●●●●●●●
0101011	053	43	2B	+	●●●●●●●●	1001011	113	75	4B	K	●●●●●●●●	1101011	153	107	6B	k	●●●●●●●●
0101100	054	44	2C	,	●●●●●●●●	1001100	114	76	4C	L	●●●●●●●●	1101100	154	108	6C	l	●●●●●●●●
0101101	055	45	2D	-	●●●●●●●●	1001101	115	77	4D	M	●●●●●●●●	1101101	155	109	6D	m	●●●●●●●●
0101110	056	46	2E	.	●●●●●●●●	1001110	116	78	4E	N	●●●●●●●●	1101110	156	110	6E	n	●●●●●●●●
0101111	057	47	2F	/	●●●●●●●●	1001111	117	79	4F	O	●●●●●●●●	1101111	157	111	6F	o	●●●●●●●●
0110000	060	48	30	0	●●●●●●●●	1010000	120	80	50	P	●●●●●●●●	1110000	160	112	70	p	●●●●●●●●
0110001	061	49	31	1	●●●●●●●●	1010001	121	81	51	Q	●●●●●●●●	1110001	161	113	71	q	●●●●●●●●
0110010	062	50	32	2	●●●●●●●●	1010010	122	82	52	R	●●●●●●●●	1110010	162	114	72	r	●●●●●●●●
0110011	063	51	33	3	●●●●●●●●	1010011	123	83	53	S	●●●●●●●●	1110011	163	115	73	s	●●●●●●●●
0110100	064	52	34	4	●●●●●●●●	1010100	124	84	54	T	●●●●●●●●	1110100	164	116	74	t	●●●●●●●●
0110101	065	53	35	5	●●●●●●●●	1010101	125	85	55	U	●●●●●●●●	1110101	165	117	75	u	●●●●●●●●
0110110	066	54	36	6	●●●●●●●●	1010110	126	86	56	V	●●●●●●●●	1110110	166	118	76	v	●●●●●●●●
0110111	067	55	37	7	●●●●●●●●	1010111	127	87	57	W	●●●●●●●●	1110111	167	119	77	w	●●●●●●●●
0111000	070	56	38	8	●●●●●●●●	1011000	130	88	58	X	●●●●●●●●	1111000	170	120	78	x	●●●●●●●●
0111001	071	57	39	9	●●●●●●●●	1011001	131	89	59	Y	●●●●●●●●	1111001	171	121	79	y	●●●●●●●●
0111010	072	58	3A	:	●●●●●●●●	1011010	132	90	5A	Z	●●●●●●●●	1111010	172	122	7A	z	●●●●●●●●
0111011	073	59	3B	;	●●●●●●●●	1011011	133	91	5B	[●●●●●●●●	1111011	173	123	7B	{	●●●●●●●●
0111100	074	60	3C	<	●●●●●●●●	1011100	134	92	5C	\	●●●●●●●●	1111100	174	124	7C		●●●●●●●●
0111101	075	61	3D	=	●●●●●●●●	1011101	135	93	5D]	●●●●●●●●	1111101	175	125	7D	}	●●●●●●●●
0111110	076	62	3E	>	●●●●●●●●	1011110	136	94	5E	^	●●●●●●●●	1111110	176	126	7E	~	●●●●●●●●
0111111	077	63	3F	?	●●●●●●●●	1011111	137	95	5F	—	●●●●●●●●	1111111	177	127	7F	Delete	●●●●●●●●

Raster Plot Syntax

The proper syntax for raster plot data is:

Control Sequence . . . ASCII Character . . . Line Terminator

All printable ASCII characters following the control sequence will be interpreted as plot data. Raster plot data must be terminated with one of the following:

- Line Feed command (decimal 10)
- Vertical Tab command (decimal 11)
- Form Feed command (decimal 12)
- Carriage Return command (decimal 13) only if option 23.1 has been installed. Option 23.1 causes a Line Feed to be appended in response to the received Carriage Return automatically.

To initiate the raster plot feature, use the appropriate control sequence:

Dot Pattern	Control Sequence	Decimal Value
even dot centers	EOT	4
odd dot centers	ENQ	5
even dot centers (see page 4-25)	ESC Y	27 89
odd dot centers (see page 4-25)	ESC Z	27 90

NOTE: A valid raster plot control sequence inserted anywhere in the data line ahead of the line terminator will cause the entire line to be plotted.

Print Modes for Raster Plots

The second function switches allow you to manually select among the print or plot modes (see Table 5–2). When manually set, the last valid mode command received before printing will determine the line print mode. The features listed as available in a particular mode are accessible on a per character basis and can be combined within a line, and in some cases, within a character matrix. However, print modes cannot be mixed on the same line. Raster plotting is available in all modes on a per dot row basis (i.e. the entire line must be plot) .

Special features that can be selected in each mode are included in the “Features Available” section of Table 5–2. The letter codes are defined as follows:

B = Bold (Double Strike) S = Shadow (Emphasized)
 U = Underlining E = Elongated (Double High)
 W = Double Wide on Per Character Basis

Table 5–2. Print Modes for Raster Plots

Mode	Panel Display	Horiz. Pitch (Chars/in)	Dot Density (Dots/in)	Features Available
1. Correspondence or Word Processing	001	10.0	100H/96V	B, S, U, E, W
2. Data Processing	002	10.0	60H/72V	B, S, U, E, W
3. Compressed Print	003	12.5	62.5H/64V	B, S, U, E, W
4. High Speed Plot	004	N/A	50H/48V	N/A
5. Condensed Print*	005	16.7/17.5	100H/72V	B, U, E W
6. Expanded Print**	006	see page 3–6	see page 3–6	B, S, U, E

* Dependent upon configuration of option 56.

**Mode 6 operable only if option 20.0 is selected.

NOTE: All features are available in all modes with the following exceptions: in Condensed (Mode 5), shadow print is not available; in High Speed Plot (Mode 4), none of the features are provided; and in Expanded Print (Mode 6), per character double wide is excluded.

High Resolution Raster Plot Syntax

The proper command syntax for high resolution graphics is:

1) Even dot center control sequence . . . plot data . . . line terminator

followed by:

2) Odd dot center control sequence . . . plot data . . . line terminator

For Example,

EOT (data) LF

ENQ (data) LF

NOTE: When plotting even dot centers using EOT, ESC Y (line feed and form feed commands denote end of plot data only), the paper will not advance. When plotting odd dot centers (ENQ, ESC Z), line feed and form feed control character denote end of plot data, and paper will advance to the next plot line or to top-of-form.

Scaling Graphics

Scaling graphics is possible by changing print modes. Each mode has a fixed dot density in dots per inch, which results in a different physical length for the same raster plot data when it is plotted in different print modes. For example, a given set of plot data that prints a one inch long line in Mode 1 (100 dots per inch) would print a line two inches long in Mode 4 (50 dots per inch). The different length occurs because the same number of dots are printed at different dot densities. Table 5-3 lists all the modes and their dot densities in dots per inch.

Table 5-3. Dot Density by Mode

Mode No.	Mode	Dots/Inch	Mode selected by ASCII code
1	Word Processing	100	ESC P
2	Data Processing	60	ESC R
3	Compressed Print	62.5	ESC V
4	High Speed Plot	50	front panel switch
5	Condensed Print	100	SI or ESC SI
6*	Expanded Print	60	SO or ESC SO

* Mode 6 operable only if Configuration Option 20.0 is selected

Exiting from Raster Plot

To exit from raster plot, you must set Configuration Option 43.0, and send one additional line terminator character after the last dot row is printed. An additional line terminator will cause the paper to advance vertically to the start of the next character line, even if the last printed dot row was between character line boundaries.

Bit Image Graphics

Bit image graphics are created by printing a series of vertical bit image data bytes which represent the binary code bit pattern. This method utilizes the 1 or true bit from a binary data byte to print dot patterns. These data bytes are actually the binary equivalent of ASCII character decimal values 0 through 255. When the data byte is rotated vertically, the result is a vertical data byte pattern with the Most Significant Bit (MSB) at the top.

Characteristics of Bit Image Graphics

The binary data byte bit pattern for the ASCII character “A” (hex 41, decimal 65) is pictured in Figure 5–1.

- If you rotate this data byte clockwise, the result is a vertical data byte pattern with the the most significant bit (MSB) at the top.
- If you print each 1 (true) bit as a dot, the result is a bit image plot of the ASCII character “A.”

The relationship of ASCII character, decimal value, and bit image plot is shown in Figure 5–2 .

- You can identify the data bytes by their binary, octal, hexadecimal, or decimal equivalents. Combined, these numeric equivalents form a bit image pattern.
- You can show each byte in a binary format, translate the byte to its decimal equivalence, and use the decimal numeral (N) in a basic command: CHR\$(N).
- You can plot bit Image patterns for any 8–bit data byte (so long as the eighth data bit is enabled) with decimal values ranging from 0 to 255, since bit image plotting is not limited to printable ASCII characters.
- You can learn the the standard ASCII characters and their equivalents by referring to the chart in Appendix A.

NOTE: Use bit image graphics in the Data Processing print mode (120 x 72 dpi). Vertical density variations in other print modes may cause white horizontal bars or overlapping of adjacent graphics lines; however, changing the line spacing can correct this problem. Refer to Chapter 4 for specific density combinations.

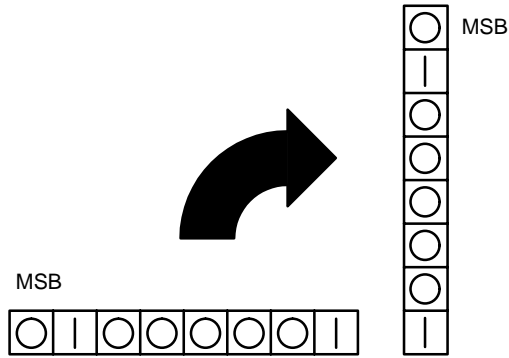

Figure 5-1. Vertical Data Byte Pattern

ASCII CHARACTER	DECIMAL VALUE	BINARY CODE EQUIVALENT	TO	VERTICALLY ROTATED DATA BYTE	PRINTED BIT IMAGE PATTERN
A	= 65	=		MSB ○ ○ ○ ○ ○ ○ 	= ● ●

Figure 5-2. Bit Image Pattern from an ASCII Character

Plotting a Bit Image Pattern

You can produce a bit image pattern in four steps:

1. Lay out the graphic(s) pattern you want to print, on a quadrille pad or graph paper.
2. Determine the decimal equivalent of each bit image data byte required to produce your pattern (Figure 5-3).
3. Write a program to generate the complete pattern.
4. Enter and run the program on the host computer.

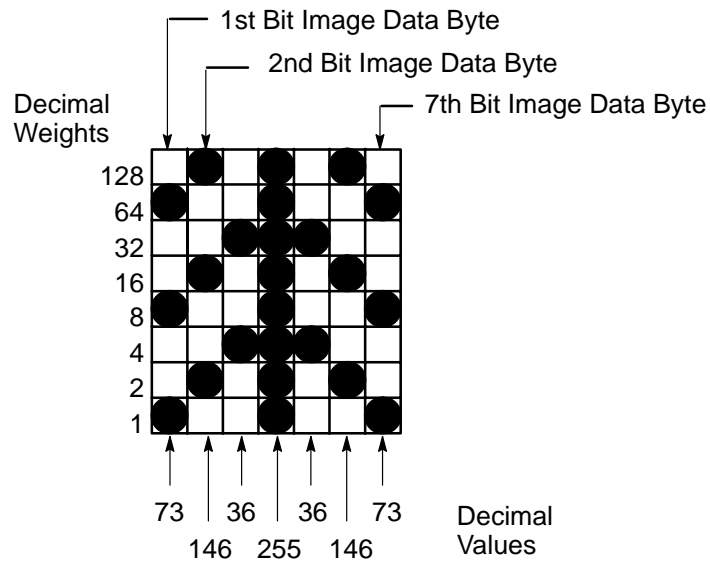

Figure 5-3. Bit Image Pattern Plan

Bit Image Density

You can print bit image graphics in different dot densities. To select dot densities, send the appropriate control code to the datastream.

Table 5–4. Bit Image Density

Control Code	Dot Density Mode	Result
ESC K	Single Density	Single density bit image graphics in the Data Processing print mode (Mode 2) are printed at 60 dots per inch (dpi) horizontally and 72 dpi vertically. In the Correspondence print mode (Mode 1), the horizontal dot density is 90 dpi and vertical dot density is 96 dpi. In the High Speed (HS) mode (Mode 3), horizontal dot density is 62.5 dpi and vertical dot density is 64 dpi.
ESC L	Double Density	The Double Density mode prints up to twice the number of dots per inch horizontally in the same space as used for single density. The vertical dot density remains the same as in the single density mode. Double horizontal density requires twice the number of input data bytes to print the same length line as for Single Density. Printing double density reduces the printing speed by half. If each 1 or true bit is plotted, the result is a bit image plot of the ASCII character "A."

Bit Image Programming Format

The Bit Image command format is:

ESC CC(n1)(n2)DATA where:

ESC	=	the Proprinter compatible header
CC	=	K, L, , Y or Z to select dot density (K=single, L=double, Y=single, Z=double)
n1, n2	=	n1+ 256(n2) defines the number of data bytes
DATA	=	the dot pattern bytes

Refer to the following guidelines when using the Bit Image Programming Format:

- The syntax of the bit image expression must be correct.
- The expression must include the appropriate dot density control code, the number of bytes of data to be plotted, and the data itself.
- The number of data bytes and the n1, n2 definition must be equal.
- Any characters following n1 and n2 will be interpreted and plotted as data until the n1, n2 definition is satisfied.
- If n1 = n2 = 0, then control codes K, L, Y, or Z are ignored:

n2 = 2(700/256) = 700 bytes of data; 2 sets of 256 with a 188 remainder
n1 = 188 = 188-byte remainder

The program statement is: ESC K(188)(2)(DATA)

NOTE: Depending on the host computer system, it may be necessary to include a width statement within the BASIC program.

- The maximum number of data bytes in the DATA portion of the program statement (when using 132-column paper) varies according to the operating mode:

At 60 dpi, Single Density = 792 bytes
Double Density = 1584 bytes

- Data in excess of the right margin is discarded. If the auto line feed is enabled, data in excess of the right margin causes a Line Feed (LF) and continue printing on the next line.

Other Bit Image Features

Bit image characters are always plotted as normal characters. Emphasized, double strike, underlines, and doubling in width commands are ignored when printing bit image characters. However, single density and double density bit image may exist in the same line, and it is also possible to include text in the same line with single density, double density, or with both. Underlines and other normal character features may appear in a print line that also contains bit image. Note, however, that the bit image characters are always printed devoid of underlines or other special features.

Modes 1 and 6

In Modes 1 and 6 it is important to take precautionary steps when mixing text and bit image data in the same line. These modes require nine steps to print an uppercase character. A maximum of eight steps can be transmitted in bit image. If the text is fully printed (contingent upon ESC 3 (n), ESC A (n), or the normal power-up LF value), there will be a gap in the bit image sections vertically. A similar situation will occur with text that includes descenders. In this case, the last row of dots and the dot rows of descenders are cut off. See Table 5-2 on page 5-5 for more information on available features for each print mode.

Modes 2 and 5

In Modes 2 and 5, the gap will not occur because the uppercase characters only occupy seven dot rows. However, the last dot row of descenders is cut off in these modes for the same reason as explained above.

Modes 3 and 4

Bit image plotting is not available in Mode 3 or 4. However, if the feature is called on a Mode 3 line, that line is printed in Mode 2, then the printer returns to Mode 3.

Darker Print

Bit images can be darkened by printing over the data a second time using a CR. For example:

```
ESC, K, n1, n2, DATA, (CR) ESC, K, n1, n2, DATA (LF)
```

P-Series Plot Mode

P-Series compatible Odd/Even Dot Plot mode is only available in P-Series printer protocol. Since plot mode can address and print any individual dot position, it is possible to produce a variety of graphics, including bar codes, complex curve graphs, pie and bar charts, block characters, or halftones.

Plot Density

Plot density refers to the number of dots per inch (dpi) printed in a single dot row. There are two types of plot density available with P-Series Plot mode graphics: normal density and double density.

Normal Density Plot Characteristics

Based on the mode of operation, the odd-numbered dot columns produce a horizontal and vertical density that varies. The following table shows the horizontal dpi and vertical dpi for the corresponding print mode. Figure 5-5 illustrates normal density dot plot.

NOTE: Different print modes cannot be mixed on the same dot row.

Print Mode	Horizontal dpi	Vertical dpi
Correspondence (NLQ)	90	96
Data Processing (DP)	60	72
High Speed (HS)	62.5	64
Barcode 145	72.5	72*
Barcode 160	80	72*

*If Configuration Option 59.0 is set to 59.1 (refer to page 4-38).



Figure 5-5. Normal Density Plot

Double Density Plot

Two separate shuttle strokes produce a double density plot. The shuttle strokes are controlled by an even plot command with corresponding dot data, and an odd plot command with corresponding dot data, which allows a maximum of 1584 dots in a single dot row at 60 dpi. The even dot plot is sent first for control of the initial plot pattern; then the odd dot plot is sent for control of the final dot pattern. The dots average .017 inches in diameter, and the vertical density remains the same in normal and high density plotting. Figure 5–6 illustrates double density plotting.



Figure 5–6. High Density Plot

Plot Data Byte Format

In P-Series Plot mode, the plot data byte format is as follows:

- Each data byte specifies six out of twelve dot columns.
- Bits 1 to 6 of the data byte address the odd-numbered dot columns in the odd dot plot mode; bits 1 to 6 of the data byte address the even-numbered dot columns in the even dot plot mode .
- Bit 6 and/or bit 7 of the data byte must be 1 (or true) in plot mode.
- Bit 8 of the data byte is not used in Plot mode and may be either a 1 or 0.
- The binary equivalent of the plot data bytes must be known to address specific dot positions accurately.

Figure 5–7 illustrates the actual data pattern sent. Whereas Figure 5–8 shows how the printer interprets the data for plotting; a dot is printed at the location addressed by each of bits 1 to 6 in the data byte that is set (1 or true).

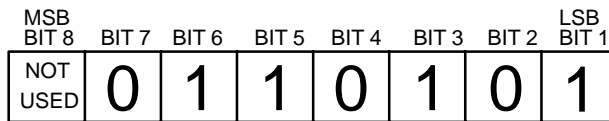

Figure 5-7. Actual Data Pattern Sent

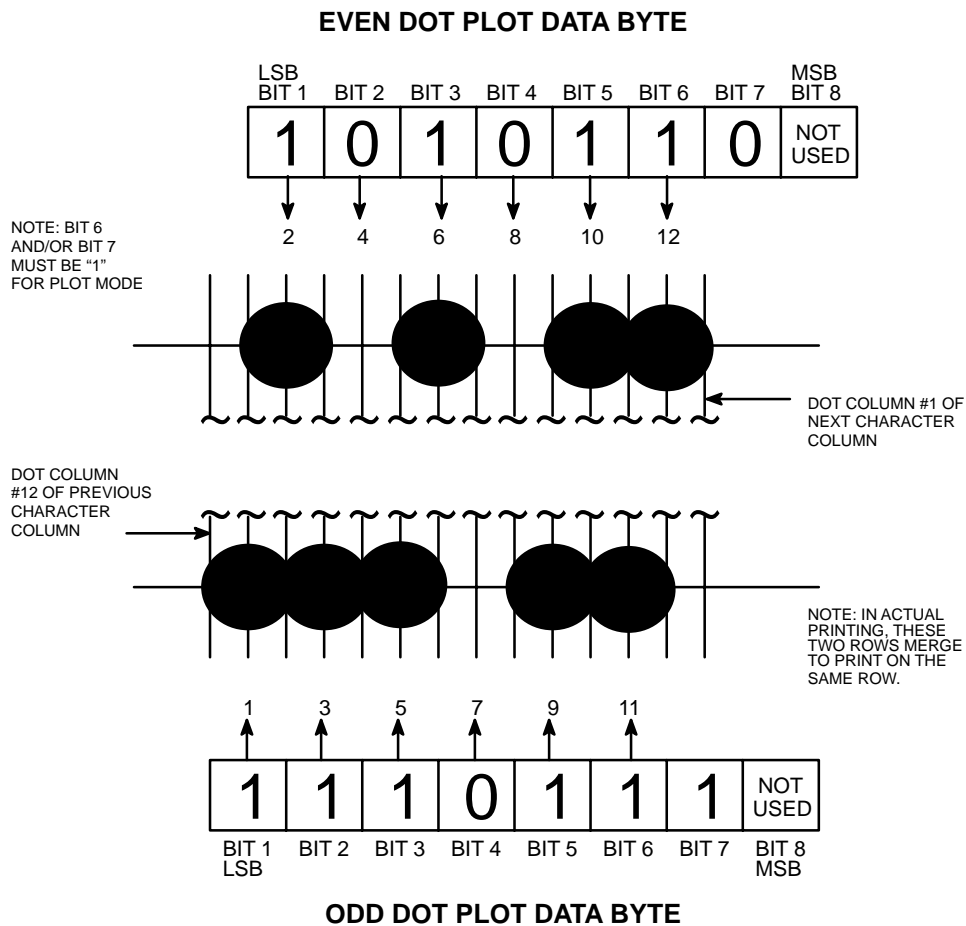

Figure 5-8. P-Series Plot Data Byte Format as Interpreted for Plotting

Plot Data Line Format

A plot data line may contain any number of plot data bytes up to 132 bytes (or 136 if Configuration Option 56.0 is set to 56.1; refer to page 4–37) for horizontal dot density of 60 dpi (Data Processing mode), or 198 bytes for a horizontal dot density of 90 dpi (Correspondence mode). When the auto line feed is disabled, any bytes over the maximum (for the particular mode) are lost. When the auto line feed is enabled and the maximum is exceeded, a line feed (LF) is forced and the remaining plot data is printed as text on the next line. The plot mode control code may occur anywhere in the line prior to the line terminator, but plot speed may decrease if it is not at the beginning of the line.

NOTE: P-Series graphics and printable symbols can not be intermixed on the same line.

Normal Density Plot

For normal density plot, the plot line format contains: the odd dot plot control code, plot data bytes, and a line terminator. The control sequence for sending the P-Series normal density plot is as follows:

1. Send the plot command code ENQ (05 hex).
2. Send the plot data bytes. (Refer to Table 5–1 on page 5–3.)
3. Send a line terminator; Line Feed or Form Feed:
 - a. For a Line Feed use 0AH. A line feed plots the contents of the buffer and advances the paper a single dot row, based on the vertical density of the current mode. A Carriage Return (CR) may be used instead of the LF code, provided the carriage return has been configured for carriage return = carriage return + line feed (CR = CR + LF).
 - b. For a Form Feed use FF, 0CH. A form feed (0C hex) plots the contents of the buffer and advances the paper to the top of the next form.

Regardless of which line terminator code is sent, the printer defaults to the previously selected print mode unless further plot control codes are provided with the data.

IMPORTANT

Failure to adhere to this format may cause unexpected results.

Double Density Plot

For double density plot, the plot line format contains: the even dot plot control code with plot data bytes, a line terminator to plot the data bytes, the odd dot plot control code and a line terminator. The control sequence for sending P-Series double density plot is as follows:

1. Send the even dot plot control code EOT (04 hex), followed by plot data bytes. (Refer to Table 5-1 on page 5-3.)
2. Send a line terminator. The line terminator allows the printer to plot the data bytes. The paper is *not* advanced in double density plot; the printer will wait for the second plot command and plot data bytes.
3. Send the odd dot plot control code ENQ (05 hex) and a second line of data, followed by a line terminator:
 - a. For a Line Feed use 0AH. A line feed plots the contents of the buffer and advances the paper a single dot row, based on the vertical density of the current mode. A CR (if CR = CR + LF is configured) may also be used with the same result.
 - b. For a Form Feed use 0CH. A form feed plots the data bytes and advances the paper to the top of the next form.

Regardless of which line terminator code is sent, the printer defaults to the previously selected print mode unless further plot control codes are provided with the data.

IMPORTANT

Failure to adhere to this format may cause unexpected results.

Plotting Data

P-Series Plot mode plots the image from the horizontal bit pattern. Figure 5-9 duplicates the pattern shown in Figure 5-4 but is modified for Odd Dot Plot. Eight dot rows are required, two characters per row, six columns per character. (The dots required to produce the pattern are shown in Table 5-1 on page 5-3.)

DOT ROW	1st CHARACTER ODD COLUMNS						2nd CHARACTER ODD COLUMNS						1st CHARACTER ASCII DECIMAL		2nd CHARACTER ASCII DECIMAL	
	1	3	5	7	9	11	1	3	5	7	9	11				
	1		●		●		●							*	42	@
2	●			●			●							73	A	65
3			●	●	●								\	92	@	64
4		●		●		●							*	42	@	64
5	●			●			●							73	A	65
6			●	●	●								\	92	@	64
7		●		●		●							*	42	@	64
8	●			●			●							73	A	65

Figure 5-9. Odd Dot Plot Pattern Plan

Programming Example with Odd Dot Plot

The following program uses the Odd Dot Plot control code to produce the image in Figure 5–10.

```
10 LPRINT "Odd Dot Plot"  
20 FOR I=1 TO 8  
30 READ R1  
40 READ R2  
50 LPRINT CHR$(5);  
60 FOR N=1 TO 25  
70 LPRINT CHR$(R1);CHR$(R2);  
80 NEXT N  
90 LPRINT  
100 NEXT I  
110 DATA 42, 64, 73, 65, 92, 64, 42, 64, 73, 65, 92, 64, 42, 64, 73, 65  
120 LPRINT
```

The image is printed 25 times, where an entire dot row is plotted in one printing pass. Therefore, the first row of all 25 images is printed in one pass, followed by the second row, etc., until all rows have been printed.

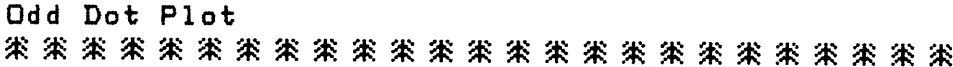
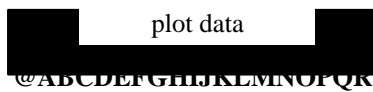

Figure 5–10. Sample Odd Dot Plot

Exiting P-Series Plot Mode

When you want to return to the print mode from the P-Series Plot mode, include an extra line feed in the data stream to maintain proper print line registration relative to the last line of plot graphics. If the extra line feed is not included, the first character line after the graphics data may be truncated, as shown in Figure 5–11.



A diagram illustrating a truncated character line. It shows a black rectangular area representing "plot data". Below it, the text "@ABCDEFGHIJKLMN" is printed, but it is truncated because it overlaps with the bottom edge of the plot data area. The characters "OPQR" are not visible.

In this example, a text line follows plot data, preceded by a single line terminator code. (Text characters extend into the range of the previously printed plot line and appear truncated.)

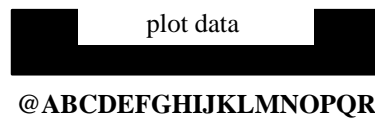

A diagram illustrating a full-height text line. It shows a black rectangular area representing "plot data". Below it, the text "@ABCDEFGHIJKLMN" is printed on a separate line, preceded by an additional line terminator code. The characters "OPQR" are also visible on the same line, indicating that the text is not truncated.

This example shows a text line following plot data, but preceded by an *additional* line terminator code. (Characters are able to be printed full-height.)

Figure 5–11. Truncated Character Line

6 EVFU

Chapter Contents

Introduction	6-2
Programming EVFU Memory	6-2
Start Load Code — 6Hex	6-2
Channel Assignment	6-3
End Load Code — 6F Hex	6-4
EVFU Command Codes	6-5
EVFU Programming Example	6-5
Troubleshooting for EVFU Programming	6-7
Using EVFU	6-8
EVFU/IGP Execute Form Mode	6-9
Relative Line Slewing	6-9
Clearing EVFU Memory	6-11

Introduction

The Electronic Vertical Format Unit (EVFU) is a software-controlled vertical formatter you load and operate from the host computer. When you load the EVFU, it disables page perforation skip (Configuration Option 50) and forms length at printer power-up (Configuration Option 52).

When you use EVFU to define print lines on a form, it increases system efficiency because it allows the printer to slew paper to a predetermined line with a single command.

Programming EVFU Memory

The EVFU memory is loaded with a program of line identification codes, one for each of the lines of the form being printed. A paper instruction (PI) is necessary with a Dataproducts interface, but is optional with a Centronics Interface. Refer to Chapter 8 to learn differences between the Dataproducts and Centronics interface.

Loading EVFU memory begins with a Start Load and ends with an End Load command after the last identification code. The TOF indicator lights when the EVFU receives the End Load command, signifying a successful program load.

Start Load Code – 6H

The EVFU must be enabled via the control panel before the EVFU can be loaded. While the EVFU is enabled, an E should appear on the first line of the ONLINE/OFFLINE display. The EVFU Start Load code of 6E (hex) with the paper instruction line (PI) high initiates the EVFU memory load routine. Subsequent data received is considered channel assignments until the end load code is received. The PI line is a hardware interface signal that is held either high or low. Refer to the Interfaces chapter for PI and data line printout information.

Channel Assignment

All data bytes received after the Start Load code are interpreted as channel assignment data until the End Load code is received.

A maximum of 12 channels can be assigned to one physical line on the form. Two eight-bit data bytes (EVFU characters) are required per line. As shown in Figure 6-1, the least significant 6 bits of the first data byte are used to assign channels 1 through 6; the least significant 6 bits of the second data byte are used to assign channels 7 through 12. If a bit is set, the corresponding channel is assigned. If a bit is not set, the channel is not assigned.

For example, assume 01 (hex) and 00 (hex) are the first two data bytes sent following the Start Load code:

01 hex = 0000 0001
00 hex = 0000 0000

NOTE: This sequence results in Channel 1 being assigned to line 1 of the form. No other channels are assigned to Line 1.

Use the following guidelines when assigning channels:

- Channel 1 TOF must be entered before any other channel data to assign Line 2 as the TOF. Sending channel data before assigning Channel 1 as the TOF will cause the loading sequence to be invalid and an EVFU memory reset.
- The last channel loaded is assigned to the bottom-of-form.
- Each line on the form requires two bytes. For blank lines, the two bytes should not contain channel assignments. That is, the data bytes sent in the load program corresponding to a blank line on the form should not set any of bits 1 through 6.

You can assign channels up to 143 lines (285 EVFU bytes). The EVFU ignores anything more than 286 bytes until the End Load code is received; if 572 bytes are received without an End Load code, the End Load code is forced and the load routine is terminated.

Line Spacing

Either 6 or 8 lpi may be used in conjunction with the EVFU. Forms length is determined by the line density selected and is much easier to calculate if only one line density is used throughout the form. Do not mix 6 lpi and 8 lpi on the same form. If they are mixed, the result will be an uncertain forms length. If mixing is unavoidable, calculate the correct forms length as follows:

- a. Count the number of lines printed at 6 lpi and divide by 6; the result will be in inches.
- b. Count the number of lines printed at 8 lpi and divide by 8; this result will also be in inches.
- c. Add the two results; the sum should not exceed the forms' length. The form's length must be set in lines, *not* inches, if the EVFU is loaded.

EVFU Memory

After printing all the forms in the run, clear the EVFU memory for the next form program by sending a Start Load command or by momentarily turning the printer power OFF and then ON.

End Load Code – 6F (Hex)

The EVFU End Load code is 6F (hex) with the PI line higher. Sending the End Load code terminates the EVFU memory load routine. After the EVFU is loaded, an L appears on the second line of the ONLINE/OFFLINE display. If the EVFU is subsequently disabled, the load will remain valid.

If the EVFU is already loaded, an End Load code will assign the current line as the new TOF line.

EVFU Command Codes

The EVFU command codes (top-of-form, vertical tab, start load, and end load) used in EVFU operation function the same way for both Centronics and Dataproducts interfaces.

Although the EVFU command codes function the same way, there are two major differences between the interfaces:

- Each interface requires a different hex code that specifies a channel number or command code.
- The Dataproducts interface requires the presence of a paper instruction (PI) in order for the EVFU to function correctly.

EVFU Programming Example

An example of loading a 20 line form program is shown in Figure 6-1 , and the result of the program is shown in

NOTE: Each entry must be made for every line of form.

Filler channels are used for lines that will not be used by the print program. Any channel except Channel 1 can be used as a filler. In Figure 6-1, Channels 2 and 8 are used as sample fillers. Details of this procedure are described in the following pages.

Sample Form Headings	Form Line Number	EVFU Load Program	Hex Code Centronics Interface No PI Line	Hex Code Dataproducts Interface PI True Line	Explanation
		SL	1E	6E	Resets EVFU — Forms length defaults to current setting of FL; enables EVFU loading.
	1	CH1	10	00	1st line of form is typically defined by CH1; interpreted as top-of-form, normally used once per form. Form feed (14), pushing TOF button, or CH1 slews paper to this line.
	2	CH2	11	01	Any EVFU channel can be a “filler” to occupy lines not defined for print program use.
NAME _____	3	CH3	12	02	CH3 defines line 3 (to be printed with NAME___).
	4	CH2	11	01	CH2 is used as a filler.
AGE _____	5	CH3	12	02	CH3 defines line 5 (to be printed with AGE___). Any channel may define any number of lines.
	6	CH2	11	01	CH2 is used as a filler.
	7	CH2	11	01	CH2 is used as a filler.
RANK _____	8	CH4	13	03	CH4 defines line 8 (to be printed with RANK___).
TITLE _____	9	CH5	14	04	CH5 defines line 9 (to be printed with TITLE___).
	10	CH2	11	01	CH2 is used as a filler.
	11	CH2	11	01	CH2 is used as a filler.
	12	CH2	11	01	CH2 is used as a filler.
ADDRESS _____	13	CH14	1D	0D	CH14 defines lines 13 (to be printed with ADDRESS___). Channel numbers do have to be used sequentially.
	14	CH2	11	01	CH2 is used as a filler.
	15	CH2	11	01	CH2 is used as a filler.
NUMBER _____	16	CH9	18	10	CH9 defines line 16 (to be printed with NUMBER___).
	17	CH8	17	07	CH8 is used as a filler.
	18	CH8	17	07	Any channel can be used as a filler. CH8 is used as a filler.
DATE _____	19	CH12	18	18	CH12 defines line 19 (to be printed with DATE___). CH12 equals Vertical Tab. A Vertical Tab (1B) or CH12 will slew paper to this line.
	20	CH8	17	07	CH8 is used as a filler.
		EL	1F	6F	End Load defines the end of the EVFU load program. EL turns the TOF indicator on to indicate EVFU loaded. TIF control is now under EVFU control. EL also defines forms length at 20 lines.

Figure 6–1. EVFU Load Program

Troubleshooting for EVFU Programming

Refer to the following guidelines when using the EVFU feature.

Printer Operation During EVFU Loading

The printer mechanism should not move during the loading of the EVFU program. If the printer starts to print or if the paper advances, an error may be present in the load program.

Forms Length

A Start Load code (1EH) clears the EVFU memory and allows the printer to respond to Form Feed (FF) codes by producing the forms length selected with Configuration Option 52.

Top-of-Form

An End Load Code (1FH) turns on the TOF indicator to signify that the EVFU memory is loaded. If a Form Feed code (Channel 1) is issued or the TOF switch is pressed, the paper will slew until the printer senses a Top-of-Form (Channel 1) code.

Line Feed

When the EVFU memory is not loaded, a Vertical Tab (VT) or any EVFU command code received through the interface causes a single line feed.

Page Perforation Skip

Loading an EVFU program automatically disables the Page Perforation Skip (Configuration Option 50).

Paper Runaway Protection

The EVFU will slew one line if the EVFU memory program is not loaded and the host computer issues a control code, line identification code, or slew code as though the EVFU memory program is loaded and a channel code is sent (but not loaded).

Using EVFU

Once the EVFU program has been enabled and loaded, the program can be accessed by sending the appropriate channel instruction to the printer. The paper is slewed to the physical line on the form having the specified channel number assigned in the EVFU memory. This is accomplished only with the PI line held high. For a data byte to be recognized as an EVFU channel instruction, the following criteria must be met:

- PI line must be high.
- Data bit 5 must be 0 (clear).

Given these two conditions, the lower 4 bits of a byte will specify the EVFU channel number. Table 6–1 lists EVFU channels and their equivalent data bytes.

NOTE: If the Skip–Over–Perforation feature is enabled, the printer will skip from the BOF position to the next TOF.

Table 6–1. EVFU Channel Assignment

First Data Byte		Second Data Byte	
Bit #	Channel #	Bit #	Channel #
8	X (don't care)	8	X (don't care)
7	X (don't care)	7	X (don't care)
6	6	6	12
5	5	5	11
4	4	4	10
3	3	3	9
2	2	2	8
1 (LSB)	1	1 (LSB)	7

EVFU/IGP Execute Form Mode

To use the EVFU with the IGP, the EVFU must be loaded while the IGP is in the Execute Form mode. Therefore, you must create and execute an empty form with the IGP prior to using the EVFU load routine. The typical procedure to load the EVFU while the IGP is in the Execute Form mode is as follows.

1. Create an empty form using the IGP Special Function Control Character (SFCC) and Create command. Do not create any form elements and do not use the forms length parameter.
2. End the Create Form mode with the End command.
3. Execute the form using the IGP Special Function Control Character (SFCC) and Execute command. Do not use the form count or page parameters.
4. Enter the EVFU Start Load code.
5. Enter the EVFU channel assignments.
6. Enter the EVFU End Load code.

NOTE: Refer to the appropriate IGP manual for forms creation and execution information.

Relative Line Slewing

Another method for moving paper when using the PI line is to vertically slew a specified number of lines within the form (rather than slewing to a specific line). To do this, three criteria must be met:

- PI line must be high
- Data bit 5 must be 1 (set)
- The EVFU must be the selected Vertical Format Unit

If these criteria are met, a specific number of lines will be slewed based on the status of data bit 1–4 as shown in Figure 6–2 . With bit 5 set and the PI line high, this type of vertical paper motion will occur whether the EVFU memory is loaded or not.

Sample Form Heading	Line Number	Hex Code with 25.0	Hex Code with 25.1	Explanation
	1	0C	0C	Form Feed
	2			
NAME_____	3	11	12	2 line slew
	4			
AGE _____	5	11	12	2 line slew
	6			
	7			
RANK_____	8	12	13	3 line slew
TITLE_____	9	10	11	1 line slew
	10			
	11			
	12			
ADDRESS____	13	13	14	4 line slew
	14			
	15			
NUMBER_____	16	12	13	3 line slew
	17			
	18			
DATE_____	19	12	13	3 line slew
	20			

Figure 6–2. Example of Line Slewing

Clearing EVFU Memory

Use one of the three following actions to clear (reset) the EVFU Memory.

- Send only the Start Load and End Load codes (no channel assignment data).
- Send an odd number of EVFU characters (channel assignment data) (detected after the End Load code is received). Remember, two data bytes are required per line.
- Send a second Start Load code, which will result in reinitializing the EVFU memory routine.

Table 6–2. EVFU Channel Instruction

Channel Selected	PI Line	Bits of Data Byte							
		8	7	6	5	4	3	2	1
1	1	X	X	X	0	0	0	0	0
2	1	X	X	X	0	0	0	0	0
3	1	X	X	X	0	0	0	0	0
4	1	X	X	X	0	0	0	0	0
5	1	X	X	X	0	0	0	0	0
6	1	X	X	X	0	0	0	0	0
7	1	X	X	X	0	0	0	0	0
8	1	X	X	X	0	0	0	0	0
9	1	X	X	X	0	0	0	0	0
10	1	X	X	X	0	0	0	0	0
11	1	X	X	X	0	0	0	0	0
12	1	X	X	X	0	0	0	0	0
X=don't care (1 or 0)									

7 Programming

Chapter Contents

Introduction	7-2
Control Codes (Quick Reference Tables)	7-3
MVP/L150 Control Codes	7-4
150B/ L150B Control Codes	7-27

Introduction

A typical transmission by the host computer is a data stream of ASCII characters that includes alphanumeric characters, spaces and various symbols and control codes. This chapter describes control codes, plotting, and host mode controls.

Control Codes

All codes in this manual are shown in hexadecimal (Hex) notation. Appendix A contains a complete listing of the ASCII characters in octal, decimal and hexadecimal notation.

Table 7-1. MVP/L150 Control Codes

Code Number (Hex)	MVP/L150 Control Code	Page #
0A	Line Feed	7-4
0C	Top-of-Form/Perforation Skip	7-5
0D	Carriage Return	7-6
0E	Alternate Character Set Select	7-7
0F	Alternate Character Set Deselect	7-7
04	Even Dot Plot	7-10
05	Odd Dot Plot	7-11
06	Lines Per Inch Spacing	7-12
08	Elongated Characters	7-13
5F	Underline	7-14
	Dot Density	7-15
	Editing	7-17
	Slewing a Specified Number of Lines	7-18
01-09, 0E, 0F 1B	Host Mode Control	7-20
	Host Mode Control Sequence Format	7-22
	Host Mode Control Sequence Placement	7-23
10H-1FH	EVFU	7-26
20	Space	7-26

Table 7-2. 150B/L150B Control Codes

150B Control Code	Page #
ASCII Characters	7-28
Horizontal Tab	7-36
Mode Selection from Host Computer	7-40
Underline Methods 1 & 2 (On/Off and Merged)	7-41

MVP/L150 Control Codes

0AH — Line Feed

During character printing, this control code causes the contents of the printer buffer to be printed, followed by a one line advance of the paper to the top row of the next character line. When multiple line feeds are sent, paper is slewed at high speed for as many lines as line feeds sent. The effect of line feed during plotting is discussed in the Programming chapter.

0CH — Top-of-Form/Perforation Skip

Control code 0CH causes the contents of the print buffer to be printed, and follows up with a top-of-form or a perforation skip operation.

With Configuration Option 50

You can set the length of the Perforation Skip by using Configuration Option 50 for one of four lengths. Configuration Option 50 can also be set to disable Perforation Skip.

NOTE: Before you power up, make sure the paper supply is properly loaded with its top-of-form set correctly. If necessary, adjust the top-of-form.

0DH — Carriage Return

Control Code 0DH causes the logical print head to move to the left margin without any motion or printing activity. Therefore, to initiate printing you must send a line feed with the carriage return. If you send configuration Option 23 for line feed on carriage return, the buffer contents will print when a carriage return is sent.

With Configuration Option 23 and 28

If you set Configuration Option 23 to 23.0 (CR=0 line feeds), the carriage return will not cause printing, and therefore, the underlining feature (Configuration Option 28) will function properly. However, printing will be delayed until you add underlines to the buffer in the desired character positions.

When you load the buffer with characters and underlines, printing will begin with the next line feed when sent by the host computer. This activity will result in a line printed with the appropriate characters underlined as shown in Figure 7-3. See page 7-14 for a complete description of the underline function.

0EH — Alternate Character Set Select

0FH— Alternate Character Set Deselect

The printer's controller board contains two sockets for character set PROMs. One socket is for the primary character set PROM and the other is for the alternate character set PROM. The primary character set PROM usually contains standard characters while the alternate character set PROM may contain special characters.

Alternate and Primary Characters

Alternate and primary characters can be mixed on a single line or printed line-by-line. To select a single alternate character, you must send code 0EH (Shift Out, alternate character set select) followed by the character code, and code 0FH (Shift In, alternate character set deselect), through the host computer. Several single alternate characters with a line also may be selected this way.

Line of Alternate Characters

To select an entire line of alternate characters, you must send code 0EH to select the alternate character set followed by a line of character codes and a line feed through the host computer. This action will print the line, advance the paper, and the printer will default to the primary character set.

If you select the alternate character set when the alternate character set PROM is not installed, a blank space will be inserted each time a character code is received. To alter this situation, the printer must receive the Shift In code or a line feed .

04H — Even Dot Plot

05H — Odd Dot Plot

Plotting allows you to address and print any individual dot position, which includes printing bar codes bar graphics, halftones, block characters, schematics and complex curves. Each Plot program line results in a horizontal print row consisting of up to 220 six-bit dot patterns, depending on the graphics mode and plot resolution selected as shown in Table 7-3 .

Table 7-3. Number of Dot Positions in a Horizontal Plot Line

Graphics Mode	Odd or Even Dot Plot		High Resolution Plot	
	Data Bytes	Dot Positions	Data Bytes	Combined Dots Positions
Correspondence (Mode 001)	200	1320	440	2640
Data Processing (Mode 002)	132	792	264	1584
Medium Resolution (Mode 003)	137.5	825	275	1650
High Resolution (Mode 004)	159	954	318	1908
High Resolution (Mode 005)	176	1056	352	2112

The dot patterns printed correspond to the received ASCII character code true or 1 bits. Each printable character has an eight-bit code, and patterns are obtained using the least significant six-bits of the code. That is, a dot is printed for every bit set (every 1) in the ASCII code except the seventh and the eighth or most significant bit (MSB).

Figure 7-1 illustrates the actual data pattern sent. Whereas Figure 7-2 shows how the printer interprets the data for plotting; the dot pattern progresses from the left to right with the left dot set by the least significant bit (LSB). The six bits are assigned to six adjacent columns (odd or even plot) within a character position. Therefore, bits having a digital value of 1 are printed, and any digital 0 bit is not printed.

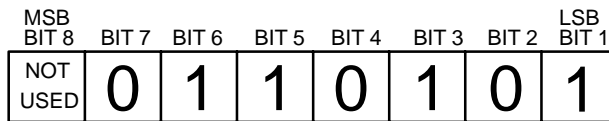

Figure 7-1. Actual Data Pattern Sent

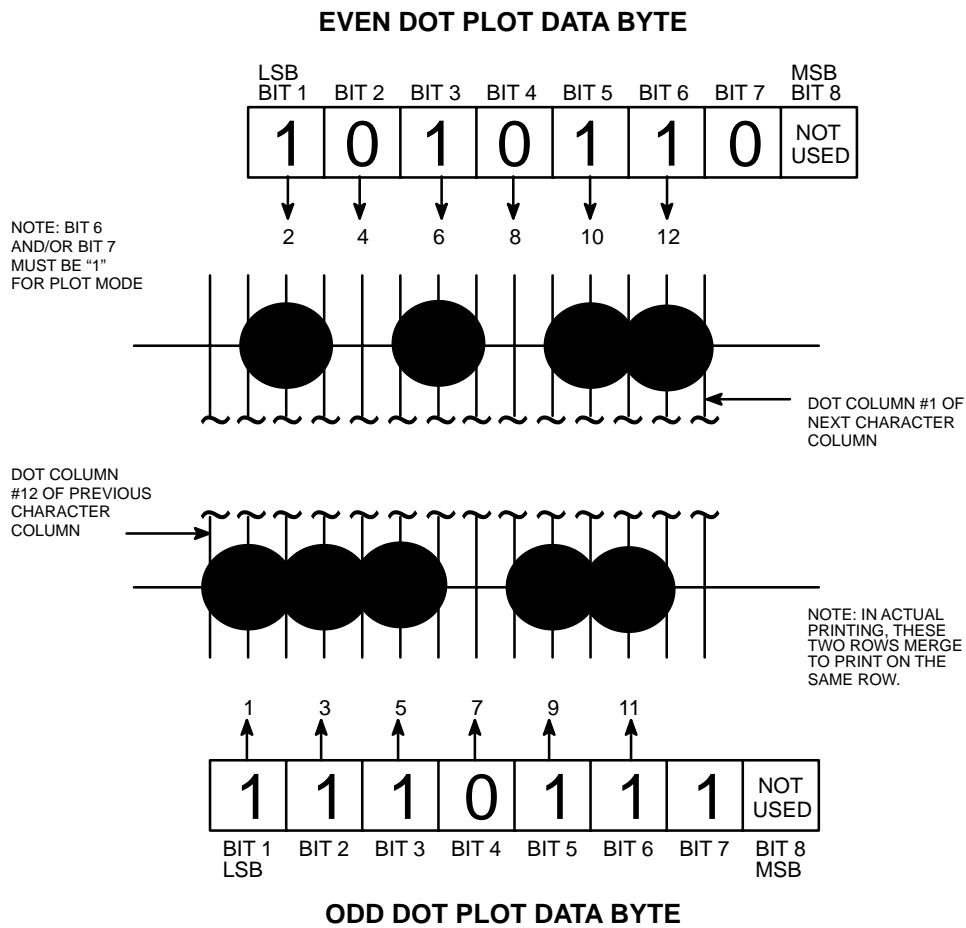

Figure 7-2. Odd Dot Plot/Even Dot Plot as Interpreted for Plotting

04 — Even Dot Plot

Even (half) dot plotting may be used to print solid lines, areas of greater density, or to improve resolution. In even dot plotting, dots are first printed in even numbered dot columns if plot command, 04H, is sent with the buffer data. Paper is not advanced for that dot row. The odd column dots are interspersed with dots printed in even numbered dot columns of that same dot row using 05H during loading of the buffer data.

Even dot plotting is specified by the code 04H. The decoded command NHDP inhibits the NOPP pulse from generating a RCLK pulse. This inhibits paper motion. The even dot code and data must precede any odd dot plot mode code and data. Paper motion occurs only after the odd dot plot shuttle excursion, although a line feed code is used for each data transfer termination.

Line Terminators

Even Dot Plot line terminators are 0AH (line feed), 0CH (form feed), and 0DH (Carriage Return). The printer will default to character printing after each plot line unless you include the control code for plot within the next data line.

Graphics and character printing can be combined on the same page, but not on the same line. It is possible to produce special characters by plotting their dot matrices, but this method is less efficient than creating a special character PROM.

With Configuration Option 43

Depending on the setting of Configuration Option 43 (plot exit) when the transition from plotting to character printing is made, adding another line feed (LF) to the last terminator may be necessary. When you use 43.0, an extra line feed is needed to maintain line registration throughout the page, and to avoid the possibility of truncating the top of the first character line after plotting. Configuration Option 43.1 does not require an extra line feed because it is automatically included.

Figure 5–11 on page 5–22 is an example of a truncated character line compared to a normal character line.

05H — Odd Dot Plot

For odd dot plot, the data line contains the odd dot plot control code (05H), the data bytes, and the terminator.

The first data byte represents the odd dots to be plotted in character column 1, and the last data byte represents the odd dots to be plotted in the highest numbered character column used. When the terminator is read, dots print in odd dot columns and the paper advances.

Line Terminators

Odd dot plot line terminators are 0AH (Line Feed), 0CH (form feed), and 0DH (carriage return). The printer will default to character printing after each plot line unless you include the control code for plot within the next data line.

Graphics and character printing can be combined on the same page, but not on the same line. It is possible to produce special characters by plotting their dot matrices, but this method is less efficient than creating a special character PROM.

With Configuration Option 43

Depending on the setting of Configuration Option 43 (plot exit) when the transition from plotting to character printing is made, adding another line feed (LF) to the last terminator may be necessary. When you use 43.0, an extra line feed is needed to maintain line registration throughout the page, and to avoid the possibility of truncating the top of the first character line after plotting. Configuration Option 43.1, does not require an extra line feed because it is automatically included.

Refer to Figure 5–11 on page 5–22 to see an example of a truncated character line compared to a normal character line.

06H — Lines per Inch Spacing

Use this code to shift from 6 lpi to 8 lpi. The 8 lpi switch must be inactive. In modes 002, 003, or 004 (not modes 001 or 005), the spacing can be changed to 9 or 10 lpi by configuring Option 51. Control Code 06 hex must be included in every line to be printed with 8, 9 or 10 lpi spacing or the spacing reverts to 6 lpi. The 8 LPI indicator lights when 8, 9 or 10 lpi spacing is selected by the code in the data stream (with the switch inactive) or when the 8 LPI switch is pressed.

08H — Elongated Characters

To form elongated characters, include Control Code 08H in the character line, which will cause each dot row to be printed twice (except the top dot row of uppercase characters and the bottom dot row of lowercase characters), and keep the number of dot columns to remain the same as in standard characters.

NOTE: Elongated characters and standard characters cannot be printed on the same line.

Elongated characters are printed at reduced speeds with an actual line spacing of 3 lpi and 4 lpi for the 6 lpi and 8 lpi settings, respectively.

With Forms Length

The forms length control is maintained because the control code (08H) is used on a line-by-line basis; that is, it must appear in each line to be printed in an elongated form. Therefore, the code may be placed anywhere in the line preceding the line terminator.

5FH — Underline

To use the underline feature, set Configuration Option 23 to 23.0 (CR=0 line feeds), and Configuration Option 28 to 28.0 (underline enable). Using this setting allows for a character to be underlined because it prevents the carriage return from producing line feeds.

When the buffer is loaded with characters and underlines, printing will begin with the next line feed sent by the host computer. Space characters must be specified for positions that you do not want underlined, which will print a character line with positions underlined as shown in Figure 7–3.

Line Number	Enter	Result
1	THE PRINTRONIX PRINTER (CR)	THE PRINTRONIX PRINTER
2	SSSS_____ (LF)	THE <u>PRINTRONIX</u> PRINTER

S = Space (20 Hex) CR = Carriage Return (0D Hex)*
LF = Line Feed (0A Hex) _ = Underline (5F Hex)

NOTE: The printer must be configured for CR=CR only. If configured for a carriage return and line feed the contents of the buffer will print when the CR code is received.

Figure 7–3. Underline Example

Dot Density

High resolution plot combines even dot plot with odd dot plot. (Normal plotting uses odd dot plot only.) Even dot columns are printed then odd dot columns are printed, which is followed by a paper advance. The result is a pattern of overlapping horizontal dots that gives the appearance of continuous lines.

Dot densities and plot speeds vary according to the mode you select for Configuration Option 30 or host mode control. Dot diameter approximates .020 inch for MVP /L150 printers, and 0.013 inch for L150/L150B printers depending on the paper stock and ribbon being used. Dot density information for the 150B/L150B printers is listed in Chapter 5.

**Table 7-4. Matrix Dot Densities and Plot Speeds
for Standard MVP Printers**

Graphics	Dot Density/ Inch		Plot Resolution Dots/Inch		Distance Between Dot Centers		Plot Speeds In/Min
	Horz.	Vert.	Horz.	Vert.	Horz.	Vert.	
High Resolution (Mode 001)	100	96 (100)	200	96	0.010	0.0104	8.3
Medium Resolution (Mode 002)	60	72 (75)	120	72	0.0167	0.0139	16.7
Medium Resolution (Mode 003)	62.5	64 (66.7)	125	64	0.016	0.0156	18.7
High Resolution (Mode 004)	50	72	100	48	0.02	0.0208	25.0
High Resolution (Mode 005)	80	72 (75)	100	96	0.010	0.0104	8.3
<i>Vertical numbers in parentheses indicate vertical dots per inch using the MVP Density Option</i>							

NOTE: Plot resolution refers to the total available dot centers.

Table 7-5. Matrix Dot Densities and Plot Speeds for L150 Printers

Graphics	Dot Density/Inch		Plot Resolution Dots/Inch		Distance Between Dot Centers		Plot Speeds
	Horz.	Vert.	Horz.	Vert.	Horz.	Vert.	In/Min
High Resolution (Mode 001)	100	96	200	96	0.010	0.010	8.3
Medium Resolution (Mode 002)	60	72	120	72	0.0167	0.013	16.7
Medium Resolution (Mode 003)	62.5	64	125	64	0.016	0.015	18.7
High Resolution (Mode 004)	72.5	72	145	72	0.0138	0.013	25.0
High Resolution (Mode 005)	80	72	160	72	0.0125	0.013	8.3

Editing

Any printable character in the data stream can replace printable characters or spaces already loaded into the printer buffer. The space character (20H) is used to skip over characters not to be replaced as shown in Figure 7-4.

NOTE: The editing function will not print the same character twice in the same location.

Example	Enter	Result
1	ABC(CR)SAB(LF)	AAB
2	ABC(CR)SA_(LF)	AAC <u> </u>
3	ABC(CR)AGF(CR)LM(LF)	LMF

S = Space (20 Hex)

CR = Carriage Return (0D Hex)*

LF = Line Feed (0A Hex)

_ = Underline (5F Hex)

Figure 7-4. Editing Example

Slewing a Specified Number of Lines

To slew a specified number of lines, set Configuration Option 25 to either 25.0 or 25.1, and Configuration Options 60 and 61 to enable the use of the PI line for EVFU control. Also, program the host computer to send a paper instruction (PI) and a Hex code that represents the number of lines to slew.

Table 7–6 shows the relationship between the configuration, the Hex code, and the resultant number of lines slewed. The example shown in Figure 6–2 on page 6–10 in the EVFU chapter is repeated in using line slew without EVFU loaded.

NOTE: Set Configuration Option 25 to 25.0 for systems that require Hex code 10 to equal a one line slew.

**Table 7–6. Slew Codes with Paper Instruction Signal
(Configuration Option 60.2 and 61.1)**

Paper Instruction Code	Hex	No. of Lines Slew/Configuration Option	
		25.0	25.1
1	10	1	1
1	11	2	1
1	12	3	2
1	13	4	3
1	14	5	4
1	15	6	5
1	16	7	6
1	17	8	7
1	18	9	8
1	19	10	9
1	1A	11	10
1	1B	12	11
1	1C	13	12
1	1D	14	13
1	1E	15	14
1	1F	16	15

Sample Form Heading	Line Number	Hex Code with 25.0	Hex Code with 25.1	Explanation
	1	0C	0C	Form Feed
	2			
NAME_____	3	11	12	2 line slew
	4			
AGE _____	5	11	12	2 line slew
	6			
	7			
RANK_____	8	12	13	3 line slew
TITLE_____	9	10	11	1 line slew
	10			
	11			
	12			
ADDRESS____	13	13	14	4 line slew
	14			
	15			
NUMBER_____	16	12	13	3 line slew
	17			
	18			
DATE_____	19	12	13	3 line slew
	20			

Figure 7-5. Line Slew (EVFU Not Loaded)

01H–09H, 0EH, 0FH, 1BH — Host Mode Control

The Host Mode Control feature allows you to change print/plot mode on a line-by-line basis without interrupting printer operation. Without this feature, print/plot mode is determined by the setting of Configuration Option 30, which is loaded when the power is turned on, or manually changed when using the control panel switches.

You can change modes on the 150B/L150B printers using host mode control by embedding the mode change control code sequence in the data stream. Control code sequences are interpreted according to the configuration options resident in printer firmware, and the printer output is modified accordingly.

Host Mode Control Feature Selection

Data stored at Configuration Option 20 determines whether the host mode control feature is enabled or disabled and what the command sequence recognition programming standard is. You can select either 20.1, P-Series programming standards, or 20.2, ANSI programming standards, (refer to Chapter 4, Configuration).

With Configuration Option 20.1

Configuration Option 20.1 enables host mode control using the P-Series programming standard. Valid control code sequence headers (beginning characters) are defined by option numbers contained in Configurations 31 through 41. Valid P-Series control code headers and their associated configuration options are listed in Table 7–7. Print mode change control code sequences must begin with the selected P-Series header.

With Configuration Option 20.2

Configuration Option 20.2 selects host mode control using the ANSI programming standard. This standard requires all print mode change control code sequences to begin with the Esc header (1BH).

NOTE: When Configuration Option 20.2 is selected, Electronic Vertical Format Unit (EVFU) channel 12 (Vertical Tab 1BH) will not operate.

Table 7-7. Configuration Options and Valid Headers

Configuration Options	Valid Header
20.1 and 31.0 (default)	01H (SOH)
20.1 and 31.1	01H (SOH)
20.1 and 32.1	02H (STX)
20.1 and 33.1	03H (EDT)
20.1 and 34.1	04H (EDT)
20.1 and 35.1	05H (ENG)
20.1 and 36.1	06H (ACK)
20.1 and 37.1	07H (BEL)
20.1 and 38.1	08H (BS)
20.1 and 39.1	09H (HT)
20.1 and 40.1	0EH (SO)
20.1 and 41.1	0FH (SI)
20.2	1BH (ESC)

NOTE: Non-Volatile Memory can be temporarily bypassed by pressing the CLEAR switch. No configuration data may be saved, and the factory default is loaded.

NOTE: One or all (up to 11) of the ASCII character hexadecimal values associated with 20.1 can be operational as a valid header.

Host Mode Control Code Sequence Format

P-Series

The P-Series (Configuration Option 20.1) control code sequence format is:

(Valid Header); [Ps q where:

- Valid Header = first character (header) of a mode change control code sequence. One of 11 hexadecimal characters can be recognized as a valid header in accordance with Configuration Option 31 through 41 defined in Table 7-7 .
- [= an ASCII “left bracket” (5BH)
- Ps = New Mode to be entered, where:
- Ps = 31H, for Mode 1
 - Ps = 32H, for Mode 2
 - Ps = 33H, for Mode 3
 - Ps = 34H, for Mode 4
 - Ps = 35H, for Mode 5
- q = Control Code Sequence Terminator = 71 hex

NOTE: Do not use any spaces in the host mode control code sequence.

ANSI

The ANSI-compatible operation (Configuration Option 20.2) requires the following Control Code sequence:

ESC [Ps q where:

- ESC = ASCII “Escape” (1BH)
- [Ps q = the same as P-Series definitions

NOTE: Do not use any spaces in the ANSI host mode control code sequence.

Host Mode Control Code Sequence Placement

A host mode control code change sequence conventionally follows a line terminator character and applies to the data occurring before the next line terminator character. The line terminator characters are line feed (LF), form feed (FF), vertical tab (VT), EVFU channels (10H to 1DH), and EVFU load codes (1EH and 1FH).

Valid Control Code Sequence

Valid Control Code sequences will be recognized anywhere in the data stream and interpreted as applying to the data occurring between the same two line terminators as the Control Code sequence.

The following examples are recognized as valid control code sequences. In each case, the data occurring between the line terminators will print in the mode specified by the control sequence.

- (Line Terminator Previous Line) (Mode Change Control Code Sequence) (Data) (Line Terminator).
- (Line Terminator Previous Line)(Data) (Mode Change Control Code Sequence)(Data) (Line Terminator).
- (Line Terminator Previous Line)(Data) (Mode Change Control Code Sequence)(Line Terminator).

NOTE: The initial line terminator shown in the examples above is not a required part of any single programming line but would occur at the end of the preceding programming line. The only requirement for any single programming line is that the mode change Control Code sequence must occur before the line terminator for that line.

If more than one one valid mode change control code sequence occurs between two line terminators, the last one will take precedence.

Control Code Sequence

The printer will not return to the previous mode when a line with a mode change is printed. The printer will always remain in the new mode until another mode is specified. Cycling the printer power will restore the default mode (Configuration Option 30); however, this mode may not be the same mode prior to power cycling.

When you include the mode change control code sequence after the number of characters (see Table 7–8), the automatic line feed is used from the original mode (or the last mode specified within that number of characters), and the new mode change affects only the characters after the line feed. The effected characters are automatically wrapped around (start a new line) and are printed in the new mode.

Table 7–8. Characters Per Line/Mode/Configuration Option

Mode	Characters Per Line/Configuration Option				
	22.0	22.1	22.2	22.3	22.4
1	132	132	104	80	80
2	132	132	104	80	80
3	165	165	132	100	80
4	159	132	132	132	80
5	176	132	132	132	80

NOTE: When using Configuration Option 22.0, an automatic line feed is not inserted. The numbers given are the maximum number of characters that can fit in a line in that mode. Additional characters above the listed numbers overprint the beginning of the line; however, there is one special case. A line feed will be inserted after 176 characters in Mode 5 because that is the limit of the printer input buffer.

Invalid Control Code Sequence

An invalid control code sequence in the data stream will be treated as normal ASCII characters. Printable characters will be printed and control characters will be processed according to existing configuration options.

For example:

If CHR\$ (4) or CHR\$ (5) are used as headers and Configuration Options 24.1 or 25.1 have not been selected (default values 34.0 and 35.0 are in effect), the line will be plotted as dot patterns rather than printed as characters. Additional headers can be defined using Configuration Options 31–33 and 36–41.

10H–1FH — Electronic Vertical Format Unit Codes

Refer to the *EVFU* chapter for programming information on the Electronic Vertical Format Unit (EVFU).

20H — Space

The printer will leave a blank space where a space character appears (in each character position) in a character line. Do not fill the end of a character line with spaces unless you configure Configuration Option 22 to insert automatic line feeds in the data stream after a particular number of characters. When underlining (Figure 7–3), specify space characters in those positions not to be underlined.

150B Control Codes

150B/L150B printers recognize certain ASCII characters and character sequences as “control codes.” These codes, when placed within a program line, cause the printer to react according to the code. There are specific codes that can:

- make the data in the associated data line print in a particular manner
- do a line feed
- move to the next tab stop
- perform some other activity where no actual printing is involved

The control codes and associated configuration options that define specific printer operations are contained in the Configuration chapter. See Table 7–9 if you want to use a programming language (such as BASIC) to control printer output.

ASCII Characters

The 150B currently recognizes 56 ASCII control codes. These codes may be single ASCII control characters (decimal numbers 00 through 31 and 127) or the Escape character (decimal 27) followed by an ASCII character and, in some cases, one or more additional decimal characters.

NOTE: Refer to Appendix A for more information on the extended ASCII character set.

In BASIC

Because most programmers are familiar with BASIC, and BASIC uses decimal numbers in LPRINT CHR\$(n) statements, all the control codes are referenced by their decimal value. For example, if you wish to transmit a Line Feed command to the printer in BASIC, you would use the following syntax:

LPRINT CHR\$(10);

NOTE: 10 is the decimal value of the ASCII control character LF, or line feed.

Table 7-9 alphabetically lists the standard set of 128 ASCII characters and their corresponding codes in binary, octal, decimal and hexadecimal. An extended ASCII character set is included in Appendix A.

NOTE: To view the ASCII control codes by function, refer to Appendix A.

Table 7–9. ASCII Character Control Codes

Character Name	Control Code (ASCII)	Dec Value CHR\$(n)	Printer Response
ACK	ACK	(6)	Sets one line spacing to 1/8, 1/9, or 1/10 inch depending on configuration 51.X.
Backspace	BS	(8)	Positions logical print head print position one space toward left margin. See Appendix A for the BS/CR Protocol.
Cancel	CAN	(24)	<ul style="list-style-type: none"> • Clears print buffer in configuration 31.0 • Ignored in configuration 31.1. Refer to Chapter 4 for details
Carriage Return	CR	(13)	Same as Line Feed if configuration 23.1 is set (see page 4–12). 23.0 set causes LOGICAL print head to be moved to the left margin. See Appendix for the BS/CR Protocol.
DLE	DLE	(16)	EVFU channel 1 (top-of-form).
DC1	DC1	(17)	EVFU channel 2.
DC2	DC2	(18)	Cancel condensed print mode (Mode 5). See SI. EVFU channel 3.
DC3	DC3	(19)	EVFU channel 4
DC4	DC4	(20)	Cancel double wide print mode. See SO. (Refer to ESC 6, configuration 20.X). EVFU channel 5.
NAK	NAK	(21)	EVFU channel 6.
SYN	SYN	(22)	EVFU channel 7.
ETB	ETB	(23)	EVFU channel 8
CAN	CAN	(24)	EVFU channel 9
EM	EM	(25)	EVFU channel 10.
SUB	SUB	(26)	EVFU channel 11.
ESC	ESC	(27)	EVFU channel 12 (Vertical Tab 46.2).

Character Name	Control Code (ASCII)	Dec Value CHR\$(n)	Printer Response
FS	FS	(28)	EVFU channel 13.
GS	GS	(29)	EVFU channel 14.
RS	RS	(30)	EVFU Start load.
US	US	(31)	EVFU End load.
Delete	DEL	(127)	<ul style="list-style-type: none"> • Produces a spare or character in position (127) in configuration 29.0. • Deletes previous character sent in configuration 29.1 • Ignored in configuration 29.2.
End of Text	EOT	(4)	Enters even dot plot mode. (See ESC L also.) Refer to page 7–10.
Enquire	ENQ	(5)	Enters odd dot plot mode. (See ESC K also) Refer to page 7–11.
Escape Codes (see page 7–30)			
Form Feed	FF	(12)	Advances paper to top of next page (or “form”). Top-of-Form (TOF) and forms length are set when paper is loaded (refer to Chapter 2). Forms length may be changed with control code Esc C from the host computer or the front panel switches.
Horizontal Tab	HT	(9)	Tabs printer to next horizontal tab stop. Refer to detailed explanation of horizontal tabbing on page 7–36.
Line Feed	LF	(10)	Advances paper feed mechanism one line. Line spacing is usually 1/6 inch (6 lines per inch) unless set to 8 or 10 lpi by control codes ESC 0 or ESC 1; or unless ESC A (n) or ESC 3 (n) have been used to modify the amount of paper moved in response to a Line Feed command.
NULL	NUL	(0) (255)	Terminates the tab setting sequence. See page 7–36 for details of horizontal tabs. Also part of control sequences.

Character Name	Control Code (ASCII)	Dec Value CHR\$(n)	Printer Response
Shift In	SI	(15)	Selects printing in condensed characters (Mode 5, 16.7 cpi) until reset by DC2. Same as ESC SI.
Shift Out	SO	(14)	Selects printing in double wide characters (refer to description of ESC 6 and Configuration 20.X) until reset by DC4 or by printing the line. Same as ESC SO.
Vertical Tab	VT	(11)	Same as Line Feed (LF). Activates a V.T.
Escape Codes			
Escape, "Cancel"	ESC CAN	(27) (24)	Exit hex dump feature (option code 31.0). (See ESC ! Configuration 31.X).
Escape, "Exclamation"	ESC!	(27) (33)	Set Hex dump feature (option code 31.0). See ESC CAN. See alternate, ESC [(option code 31.1).
Escape, "Equal"	ESC =	(27) (61)	Resets MSB to 0. Refer to ESC >.
Escape, minus Decimal Number	ESC - n	(27) (45) (n)	<ul style="list-style-type: none"> • n= 1 (or 49) sets underline feature. • n=) (or 48) resets underline feature. (Refer to page 7-41)
Escape, "Greater Than"	ESC >	(27) (62)	a) Sets MSB as 1. When this code is input, the MSB of an 8-bit data input following this code becomes a logic 1. This allows computers with seven data bits to access characters 160-255. b) ESC > does not allow access to address range 128-160 foreign characters. Those can be accessed only using ESC 6.
Escape, "At"	ESC @	(27) (64)	General Printer Reset Command a) Clear horizontal tabs to default values. b) Clear underlines, clear emphasis, clear double strike. c) Reset print mode to current default. d) Reset SO or ESC SO if pending. e) Reset TOF to current location f) Clears hex dump. g) Reset line length, forms length, script, and Data Bit 8 to power-up value.

Character Name	Control Code (ASCII)	Dec Value CHR\$(n)	Printer Response
Escape, "Pound"	ESC#	(27) (35)	Cancels the MSB (Data Bit 8) control set by ESC = or ESC >.
Escape, "*"	ESC*	(n1) (n2)	Selects graphic density n, where: 0=60 dpi; 1=120 dpi; 2=120 dpi; 3= 150/145 dpi; 4= 80 dpi; 5=75/72.5 dpi; 6= 90 dpi; 7=160 dpi
Escape, "[mq"	ESC [mq		Selects print mode m where: 1=mode 4 . . . 5=mode 5
Escape, "Shift Out"	ESC SO	(27) (14)	Same as SO.
Escape, "Shift In"	ESC SI	(27) (15)	Same SI.
Escape, "Left Bracket"	ESC [(27) (91)	Used with option code 31.1. Same as ESC ! using 31.0.
Escape, "h"	ESC h	(27) (104)	Used with option code 31.1. Same as ESC I using 31.0.
Escape, "l"	ESC l	(n)	Sets the left margin at n.
Escape, "n"	ESC n	(27) (110)	Used with option code 31.1. Same as ESC P using 31.0
Escape, "r"	ESC r	(27) (114)	Used with option code 31.1. Same as ESC R using 31.0.
Escape, "x"	ESC x	(n)	Sets line spacing to n/144 inch.
Escape, "A", Dec. No. 0-85	ESC A (n) (0 ≤ n ≤ 85)	(27) (65) (n)	Sets n/72 inch line spacing. NOTE: Line Feed value set by ESC A (n) does not need to be loaded by ESC 2. Sending an ESC A (n) will cause 6 lpi.
Escape, "C", Dec. No. 1-127.	ESC C n	(27) (67) (n)	Sets forms length in lines, where: 1 ≤ n ≤ 127, TOF light turns on. See ESC C 0 n, also.
Escape, "C", "zero", number	ESC C 0 n	(27) (67) (0) (n)	Sets forms length in inches, where: 1 ≤ n ≤ 22

Character Name	Control Code (ASCII)	Dec Value CHR\$(n)	Printer Response
Escape, "D" n1, n2... n28... 1st number, terminator, 2nd number	ESC D	(27) (68) (n1) (n2)	Set horizontal tabs. Refer to page 7–36 for details on horizontal tabs.
Escape, "E"	ESC E	(27) (69)	See emphasized print mode. Ignored if Mode 5 is active.
Escape, "F"	ESC F	(27) (70)	Reset emphasized print mode.
Escape, "G"	ESC G	(27) (71)	Set double strike mode.
Escape, "H"	ESC H	(27) (72)	Reset double strike mode.
Escape, "I"	ESC I	(27) (73)	Sets double high print feature (option code 31.0). Associated line ONLY. See alternate ESC H (option code 31.1).
Escape, "J"	ESC J	(n)	Prints the current buffer and produces an immediate one time line feed of n/216.
Escape, "K"	ESC K	(27) (75)	Sets odd dot feature. All subsequent characters in line plotted as ASCII patterns. Plot on odd dot centers. Refer to page 7–11.
Escape, "K" Dec. No. 1 Dec. No. 2	ESC K (n1) (n2)	(27) (75) (n1) (n2) (data)	Sets Single Density Bit Image feature. Operates in Modes 1, 2, and 5. This code must be followed by bit image data which establishes the bit pattern(s).
Escape, "L" Dec. No. 1 Dec. No. 2	ESC L (n1) (n2)	(27) (76) (n1) (n2)	Sets Double Density Bit Image feature. (Printer will print both even and odd dot centers.) Operates in Modes 1, 2, and 5 in a manner similar to ESCAPE K. A dot pattern obtained using ESCAPE L would have twice the dot density of one using the ESCAPE K feature.
Escape, "M"	ESC M		Turns elite mode ON (See Configuration Option 59.1, 12.5 cpi)

Character Name	Control Code (ASCII)	Dec Value CHR\$(n)	Printer Response
Escape, "N" Dec. No. 1–127	ESC N(n) $1 \leq n \leq 127$	(27) (78) (n)	<ul style="list-style-type: none"> a) Enables host computer to set skip over perforation to be n lines. b) Ignored if n is greater than forms length. c) Clear by ESC @. d) Must be reset after forms length is changed either by host computer for front panel. e) Skip reset to power up value when operator changes forms length via front panel if host has set skip via ESC N, n.
Escape, "O"	ESC O	(27) (79)	Disables skip over perforation (sets skip = 0)
Escape, "P"	ESC P	(27) (80)	Sets word processing (Mode 1) (option code 31.0). See alternate, ESC N (option code 31.1).
Escape, "Q"	ESC Q	(n)	Sets the right margin at (n).
Escape, "R"	ESC R	(27) (82)	Sets data processing (Mode 2) (option code 31.0). See alternate, ESC r (option code 31.1).
Escape, "S" Dec. No. (1) n=0 or 48 (2) n=1 or 49	ESC S (n)	(27) (83) (n)	Sets superscript (n=0 or 48) or subscript (n=1 or 49) feature. Operates in Modes 1, 2, 5, and 6. Superscripts and subscripts can both occupy the same character column. Scripted characters can be individually specified as double wide, double struck, or emphasized.
Escape, "T"	ESC T	(27) (84)	Clears superscript/subscript print feature if set.
Escape, "V"	ESC V	(27) (86)	Set 12.5 cpi print (Mode 3). Upper case character set and underline ONLY.
Escape, "W"	ESC W(n)	(27) (87) (n)	<ul style="list-style-type: none"> a) n=1 or 49; Set and hold double wide printing. When ESC, W, 1 is asserted, double wide isn't cleared by printing. b) n=0 or 48: Clear double wide printing.

Character Name	Control Code (ASCII)	Dec Value CHR\$(n)	Printer Response
Escape, "Y"	ESC Y	(27) (89) (n1) (n2)	a) Option code 34.0 causes ESC Y to act as even dot plot. (Same as 04 code when 40.0 is set.) b) Using 34.1, ESC Y is ignored; data following is interpreted, literally.
Escape, "Z"	ESC Z	(27) (90) (n1) (n2)	a) Option code 34.0 causes ESC Z to act as odd dot plot. (Same as 05 code when 40.0 is set.) b) Using 34.1, ESC Z is ignored; data following is interpreted literally.
Escape, Zero	ESC 0	(27) (48)	Sets 8 lines per inch for the following lines. Lights 8 lpi LED.
Escape, One	ESC 1	(27) (49)	Sets 10 lines per inch for the following lines. Lights 8lpi LED.
Escape, Two	ESC 2	(27) (50)	Sets 6 lines per inch for the following lines. Turns 8 lpi LED off.
Escape, Three Decimal Number 0–255	ESC 3(n) ($0 \leq n \leq 255$)	(27) (51) (n)	Sets line spacing equal to $n/216$ inch.
Escape, Six	ESC 6	(27) (54)	Selects decimal range 128–160 to be printable characters until cancelled by ESC 7.
Escape, Seven	ESC 7	(27) (55)	Selects decimal range 128–160 as control characters.
Escape, Eight	ESC 8		Turns the paper sensor OFF.
Escape, Nine	ESC 9		Turns the paper sensor ON.
Escape, –0	ESC –0		Turns the underline mode OFF.
Escape, –1	ESC –1		Turns the underline mode ON.
Escape, –2	ESC –2		Turns the double–underline mode ON
Escape, –3	ESC –3		Turns the double–underline mode OFF

Horizontal Tab

Horizontal tabs enable you to put text at a precise column in a print line. Up to 28 stops may be set at a time, spanning character columns 1–216.

Loading a Horizontal Tab Table

You may design and load your own horizontal tab table and tab the print head with CHR\$ (9), the decimal value of ASCII control character HT. To make use of the custom Horizontal Tab feature you must first load a tab table and then make calls to the table with CHR\$ (9).

The proper syntax for loading the tab table is:

LPRINT ESC “D”CHR\$(N2);..CHR\$(128) (or CHR\$(0)) where:

ESC “D”	=	load HT table
CHR\$(n)	=	decimal numbers (1 to 216) indicating tab stops at designated character column number. (See “Hard Copy Considerations” in this chapter.)
CHR\$(0) or CHR\$(128)	=	load HT terminator

NOTE: CHR\$(0) and CHR\$(128) are not allowed as tab stops.

Calling a Horizontal Tab Table

After the horizontal tab table has been loaded, you may use the table by sending CHR\$ (9) to call each tab.

Example: **LPRINT...DATA...CHR\$ (9)DATA**

Density Specifications

The following table list both the horizontal and vertical dot densities (dots/inch) in each of the print modes as well as their character pitches in inches:

	Standard MVP	L150	136C
Mode 1 Pitch Chars/line	100 x 96 10 132	100 x 96 10 132	100 x 96 10 132
Mode 2 Pitch Chars/line	60 x 72 10 132	60 x 72 10 132	60 x 72 10 132
Mode 3 Pitch Chars/line	62.5 x 64 12.5 165	62.5 x 64 12.5 165	62.5 x 64 12.5 165
Mode 4 Pitch Chars/line	50 x 48 10/8.3 132/110	72.5 x 72 12.1/12.5 159/165	50 x 48 10/8.3 136/113
Mode 5 Pitch Chars/line	100 x 72 16.7 220	80 x 72 13.3 175	105x 72 17.5 238

Mode 1 = Correspondence or Word Processing

Mode 2 = Data Processing

Mode 3 = Draft Mode

Mode 4 = High Speed plot; 8.33 cpi (45.0 and 59.0)

= Draft Mode; 10 cpi (45.1 and 59.0)

= High Density Bar Code (12.5 cpi with MCU 20.25) or
(12.1 cpi with LM .0x MCU)

Mode 5 = Condensed Print; 16.7 cpi (59.0 and 56.0)

= Condensed Print; 17.5 cpi (59.0 and 56.1)

= High Density Barcode; 13.3 cpi (59.1)

Standard = Normal Mode (59.0 and 56.0)

L150 = Barcode Mode (59.1)

136 C = 136-column print mode(56.1 and 59.0)

Hard Copy Considerations

Follow these guidelines for using horizontal tabs:

- Tabs must be set in ascending order.
- The maximum decimal value of $n(i)$ will depend on the mode in use.

NOTE: Be sure proper width will accommodate tab settings.

- If the length of STRING (i) after TAB (i) is greater than the spaces between TAB (i) and TAB (i+1) then STRING (i+1) will be printed at TAB (i+2).
- Any illegal loading sequence will be ignored and the default condition shall be applied when HT is called.
- If there are more calls than there are TABs then the first string corresponding to the FIRST EXTRA CALL will be printed one space after the last string corresponding to the last tab in the table.
- Horizontal tab and automatic underline features may be used in the same line. If underline is entered before the call for tab then the tab is underlined also. If the call for tab is entered before the underline sequence, then only the text assigned by the tab will be underlined.
- When changing modes after setting tabs:
 - a. Auto LF feature not set: a call to a tab stop beyond the physical line will cause wraparound of the character line. For example, tab stop set to 144 in Mode 5 (16.7 cpi) current print mode is Mode 2 where column 132 is maximum.
 - b. If auto line feed is set, a call to a tab location beyond the physical line length will cause the auto Line Feed to act, and the data at the tab stop will appear on the next line.
- At power-up the HT table is set as shown in Table 7-10.

Table 7-10. Horizontal Tabs at Power-up

TAB#	TAB position	MODE		
		(Mode 1 & 2)	(Mode 3)	(Mode 5)
0	8			
1	16	.	.	.
2	24	.	.	.
3	32	.	.	.
4	40	.	.	.
5	48	.	.	.
6	56	.	.	.
7	64	.	.	.
8	72	.	.	.
9	80	.	.	.
10	88	.	.	.
11	96	.	.	.
12	104	.	.	.
13	112	.	.	.
14	120	.	.	.
15	136		.	.
16	144		.	.
17	152		.	.
18	160		.	.
19	168		.	.
20	176			.
21	184			.
22	192			.
23	200			.
24	208			.
25	216			.

Mode Selection from Host Computer

Mode selection from the host computer allows you to change the printing mode of the printer via the I/O, by using appropriate control sequences. All print modes can be selected from the front panel as well as from power-up, via Configuration 30.X.

If the mode is set from the front panel, the first print line will set the print mode back to either to: (1) the power-up default mode, or (2) Mode 5; if Mode 5 was asserted when the front panel was used to change the mode.

Sequences and Other Modes

Mode	Character/Mode	CPI	Set/Select	Reset
5	Condensed	16.7	ESC, SI, SI (Hex 1B, 0F; DEC Set17, 15)	DC2 (see Note)
3	Compressed	12.5; high speed	ESC V	Selecting another print mode
2	Data Processing	10; high speed	ESC R	Selecting another print mode
1	Word Processing	10; high speed	ESC P	Selecting another print mode

NOTE: DC2 resets mode 5. Printer stays in Mode 5 until another mode is selected or DC 2 is sent. When the DC2 is sent, the printer will reset to the power-up mode as set by configuration 30.X if no other mode is asserted.

Underline — Methods 1 & 2

The printer will automatically generate the underline as required by the particular character line transmitted. Leading and trailing spaces are not underlined. Use the following guidelines and see Figure 7–6:

- Underlines start and stop on the normal character boundary and are permissible at 6 or 8 lpi.
- The ESC sequences can be repeated multiple times within a line and can, by themselves, constitute a printable line comprised of only underlines (assuming configuration 28.1 is set).
- Spaces will be underlined as normal printable character, if they are preceded by an ESC – 1 sequence. Any incorrect sequence will be ignored.
- The Underline mode set by ESC – n is not cleared by performing a print or paper movement, but stays in effect until the ESC–0 sequence is received or the printer is powered off.

Method 1 (On/Off)

On

Underlines are turned on by the control sequence ESC – 1 (or hex string 1B, 2D, 01) where the character 1 in the ESC sequence is the second character (SOH) in the ASCII character chart (see Appendix A).

NOTE: Hex 31 can replace hex 01.

Off

Underlines are turned off by the control sequence ESC – 0 (or hex string 1B, 2D, 00) where the character 0 in the ESC sequence is the first character (NUL) in the ASCII character chart (see Appendix A).

NOTE: Hex 30 can replace hex 01.

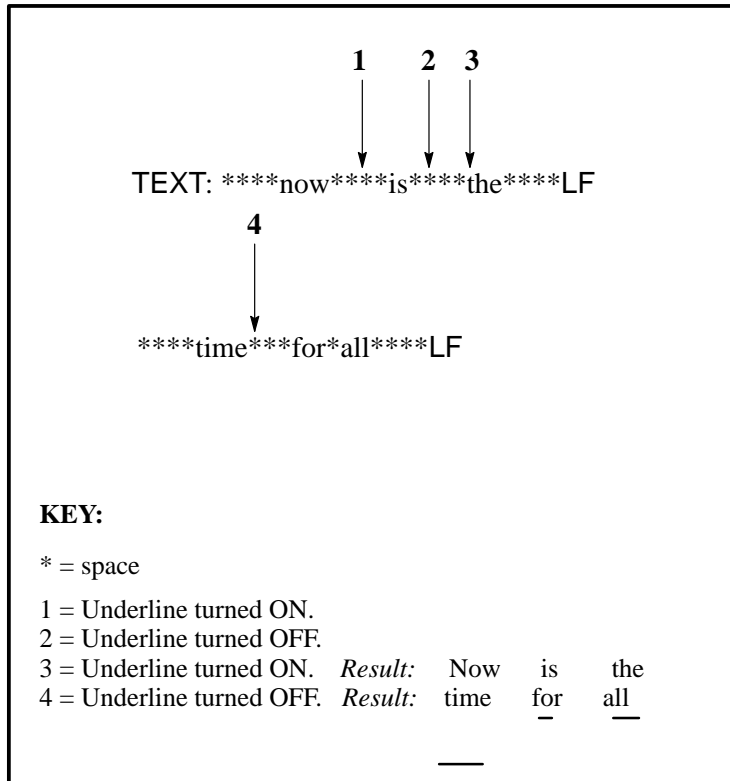

Figure 7-6. Leading and Trailing Spaces

Method 2 (Merged)

Underlining can also be accomplished by sending the sequence:
TEXT, CR, SP/UL, line terminator. Underlining is on a per character basis.

Example:

Sent: A B C D E, CR, SP, UL, SP, SP, CR, LF

Printed: ABCDE

- It isn't necessary to match the length of the string between the text and underlines, and spaces beyond that required to position the underlines as desired.
- Reversing the order of the string to: SP/UL, CR, TEXT, CR, LF is permissible following the same positioning requirement.

Compatibility with Other Features

- Configuration 28.0: leading and trailing spaces are not underlined (reference (ESC) (-) (n) only).
- Configuration 28.1: everything following (ESC) (-) (CHR\$) 1 or 49 is underlined.
- Underlines are functional with all features except plot and any lpi spacing such as 10 lpi in which there are no available dot rows for the underlines.
- Underlines are functional with automatic LF; configuration 23.X.23.O must be set (CR = no Line Feed) in order to use CR as a flag for underlining.

8

Interfaces

Chapter Contents

Introduction	8-2
Centronics and Dataproducts Interface Characteristics	8-2
Centronics Interface	8-3
Dataproducts Interface	8-5
Interface Configuration Options 60-99	8-8
Switching Interfaces	8-26

Introduction

The MVP-Series printer interfaces are logically and electronically compatible with the Centronics and Dataproducts interfaces. The Centronics and Dataproducts interfaces allow the parallel transfer of 8 data bits, one byte at a time. The switch from one interface to the other requires a simple change of the printer's input/output (I/O) cable, terminating resistors, and Configuration Option 66 (see "Switching Interfaces" on page 8-26).

Centronics and Dataproducts Interface Characteristics

Centronics and Dataproducts interface circuit characteristics are as follows.

Interface Cable

The cable must not exceed 40 feet and must allow the transmission of signals having standard TTL logic level (0.0V to +0.5V low and +2.4V to +5.25V high). Use shielded cable with the shield grounded to minimize electrical noise.

Logic Levels

0.0V to +0.5V low; +2.4V to +5.25V high.

Receivers

TTL 74LS14 with a 1000-ohm pull-up terminating resistor pack in location 18C (Centronics) or optional 220-ohm and 330-ohm pull-up/pull-down terminating resistor packs in locations 18C and 17C, respectively (Dataproducts).

Drivers

TTL 7407 with a 1000-ohm pull-up terminating resistor pack in location 15C (Centronics or Dataproducts).

Terminating Resistors

The Centronics parallel interface requires that 1000-ohm resistor packs be installed at Parallel Controller PCBA coordinates 15C and 18C see Figure 8-5. Typical circuits using the resistors are shown in Figure 8-6. The Dataproducts Interface requires the 220-ohm resistor pak at coordinates 18C and a 300-ohm pack at coordinates 17C. A 1000-ohm pack is installed at location 15C. A resistor pack is not required with the Serial Controller PCBA.

Logic Configuration

Standard positive true; Option Code 63 is configurable to negative true logic.

Centronics Interface

The Centronics (standard) interface transfers parallel data bytes at a rate of up to 200,000 characters per second. The interface requires an I/O cable assembly with an Amphenol compatible connector (*Printronic* P/N 110376-001) as shown in Figure 8-1, connected to the properly terminated Parallel Controller PCBA at P4. Configuration Option 66 must be set to 66.0

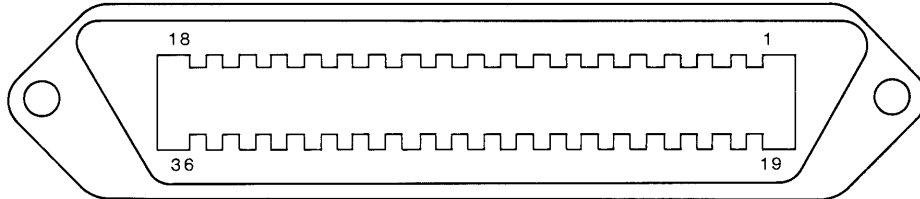

Figure 8-1. Centronics Connector

Figure 8-2 illustrates the Centronics interface timing sequence. Data transfer is initiated when the host computer places a data byte on the data lines. After a delay of at least 50 ns, the host computer issues DATA STROBE to latch the data byte into the receiver latches. DATA STROBE must be at least 100 ns in duration. Normally, the printer responds with a 4 μ s ACKNOWLEDGE pulse and BUSY. If Configuration Option 65.1 is selected, BUSY will be suppressed until the host computer sends a line terminator control code byte (FF, LF, or EVFU). Table 8-1 describes the Centronics interface signals and pin assignments and Table 8-2 describes the Dataproducts interface signals and pin assignments.

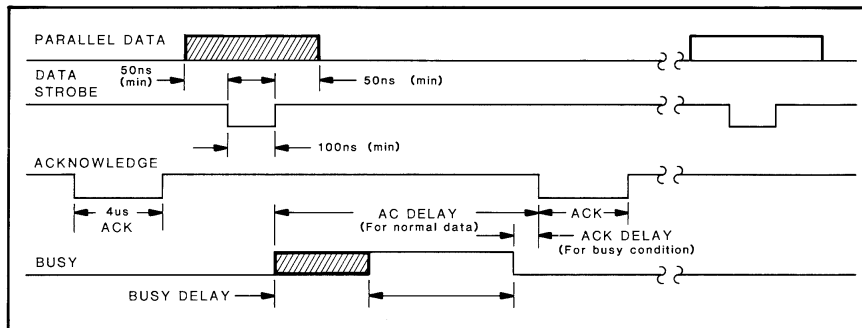

Figure 8-2. Centronics Interface Timing Sequence

Table 8–1. Centronics Interface Signals and Pin Assignments Input Signals

Input Signals	Description	Connector	
		PIN	RETURN
DATA STROBE	A low active true pulse (at least 100 ns duration) from the host computer to clock data into the printer. Data lines must stabilize for at least 50 ns before DATA STROBE is sent.	1	19
DATA LINE 1	Eight high active lines from the host computer forming a character byte or a Control Code byte. Refer to Configuration Option 60, Section 5.6, for DATA LINE 8 control.	2	20
DATA LINE 2		3	21
DATA LINE 3		4	22
DATA LINE 4		5	23
DATA LINE 5		6	24
DATA LINE 6		7	25
DATA LINE 7		8	26
DATA LINE 8		9	27
PAPER INSTRUCTION	Enables EVFU control (when clocked into printer by DATA STROBE). Effective only when Configuration Option 60 is set 60.2 and 61 is set to 61.1. DATA STROBE timing is the same as for data lines.	15	14

Table 8–2. Centronics Interface Signals and Pin Assignments Output Signals

Output Signal	Description	Connector	
		PIN	RETURN
ACKNLG	Low active pulse from the printer to indicate the printer is ready for the next data transfer.	10	28
SLCT	A high active level (when PE level is low) from the printer to indicate the printer is ready to receive data and the RDY switch has been activated.	13 32	N/A
PE	A high active level from the printer to indicate a check (CHK) condition.	12	N/A
BUSY	A high active level from the printer to indicate a check (CHK) condition.	11	29
5 VOLT TEST	Supplies +5V (at one Ampere) output for powering a Printronix Test Exerciser (Exerciser not required for the L150)>	18	N/A
CHASSIS GROUND	Connections for a cable shield.	17	N/A
SPARE	Not Used.	30 31 32 34 34 36	

Dataproducts Interface

The optional Dataproducts interface transfers parallel data at a rate of up to 400,000 characters per second. It requires an I/O cable assembly with Winchester-compatible connector (*Printronix* P/N 110628-001) as shown in Figure 8-3 or an Amphenol-compatible connector (*Printronix* P/N 110638-001) connected to the properly terminated Parallel Controller PCBA at P4. Configuration Option 66 must be set to 66.1

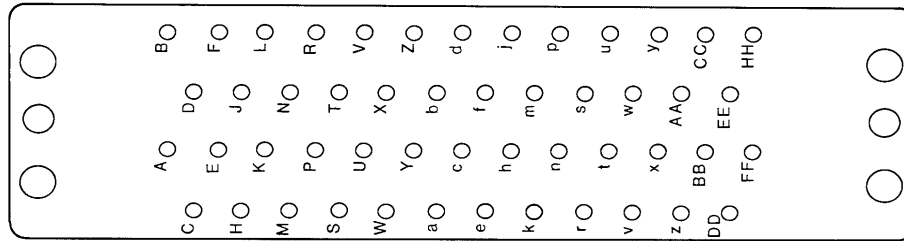

Figure 8-3. Dataproducts Connector

Figure 8-4 illustrates the Dataproducts interface timing sequence. The printer signals status to the host computer by putting a high on the DATA REQUEST line along with READY and ONLINE. The host computer places a data byte on the input lines. After the data has stabilized for at least 50 ns, the computer issues DATA STROBE to latch the data byte into the receiver latches. DATA STROBE also causes DATA REQUEST to go low, and must go low again itself at least 50 ns before the data byte is withdrawn by the host computer. At least 1 us later, the printer will return the DATA REQUEST line to a high state and again be ready to accept data.

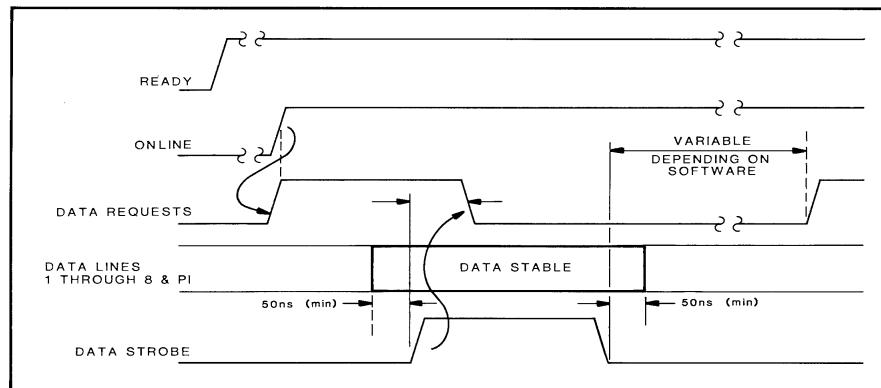

Figure 8-4. Dataproducts Interface Timing Sequence

Table 8–3. Dataproducts Interface Signals and Pin Assignments Input Signals

Input Signals	Description	Amphenol		Winchester	
		Pin	Return	Pin	Return
DATA STROBE	A high active pulse (requires Configuration Option 62.1) of at least 100 ns duration sent by the host computer to indicate data is ready to be sent to the printer.	38	37	j	m
PAPER INSTRUCTION (PI)	A high active level from the host computer clocked into the printer with the same timing as the data lines. Effective only when Configuration Option 60 is set to 60.2 and 61 is set to 61.1	30	14	p	s
DATA LINE 1	Eight high active level (low active under Configuration Option 63.1) from the host computer that form a character byte or control code byte.	19	3	B	D
DATA LINE 2		20	4	F	J
DATA LINE 3		1	2	L	N
DATA LINE 4		41	40	R	T
DATA LINE 5		34	18	V	X
DATA LINE 6		43	42	Z	b
DATA LINE 7		36	35	n	k
DATA LINE 8		28	44	h,u	e,w
PARITY	The state of this line is host computer controlled. The total number of active levels on the PARITY line plus the eight DATA Lines is an even number (even parity check) or an odd number (odd parity check).	29	13		

NOTE: Refer to Configuration Option 60, Section 5.6 for DATA LINE 8 control.

Table 8–4. Dataproducts Interface Signals and Pin Assignments (Continued)
Output Signals

Output Signals	Description	Amphenol		Winchester	
		Pin	Return	Pin	Return
READY/PE	A high active level from the printer to indicate: 1. AC power and DC voltages present. 2. Printer paper loaded properly. 3. Printer is not in a CHK condition.	22	6	CC	EE
ONLINE	High active level from the printer to indicate: 1. The READY line is true. 2. RDY switch on the operator control panel has been activated.	21	5	y	AA
DATA REQUEST (demand line)	High active level from the printer to synchronize host computer data transmission with printer timing. High level indicates printer data request. The signal remains high for as much as 250 ns after DATA STROBE signal is received then the DATA REQUEST drops to low (false) and remains low until the data is stored in the printer's buffer.	23	7	E	C
GROUND	Connections for cable shield.	39		M,f, FF	
VERIFICATION	Jumper between two pins on the interface connector enables verification that the interface connector is seated correctly	46 45		x y	
TEST	Supplies +5V (at one Ampere) output for the <i>Printronix</i> test exerciser. (Exerciser not needed for L150.)	12		HH	

Interface Configuration Options 60–99

The final step in the printer/host computer interfacing procedure requires obtaining a configuration printout (self-test 00.1) to ensure that the correct interface control configuration options (addresses 60–99) are set. Addresses 60–66 apply to the parallel (Centronics and Dataproducts) interfaces. Refer to Chapter 4 for reconfiguration procedures.

Table 8–5. Quick Reference Table for Interface Configuration Options 60 –99

Configuration Number	Printer Type	Configuration Option	Page #
60	All	Data Line 8 with Parallel Interface	8–9
61	All	Paper Instruction with Parallel Interface	8–10
62	All	Data Strobe Line Polarity with Parallel Interface	8–11
63	All	Data Lines and Response Line Logic Polarity with Parallel Interface	8–12
64	All	Reserved for Future Use	
65	All	Busy	8–13
66	All	Parallel Interface Selection	8–14
67–69	All	Reserved for Future Use	
70	MVP/L150	Serial Interface/Protocol Selection	8–15
71	MVP/L150	Serial Data Transfer Baud Rate	8–16
72	MVP/L150	Data Word Interface Configuration	8–17
73	MVP/L150	Transmitted Data Polarity	8–18
74	MVP/L150	Request to Send (RTS)	8–19
75	MVP/L150	Clear to Send (CTS) and Carrier Detect (CD)	8–20
76	MVP/L150	Data Set Ready (DSR–RS–232 pin 6)	8–21
77	MVP/L150	Reverse Channel (RC)	8–22
78	MVP/L150	Data Terminal Ready (DTR)	8–23
79	MVP/L150	XON Buffer Level Threshold	8–24
80	MVP/L150	XOFF Buffer Level Threshold	8–24
81	MVP/L150	Current Loop Out	8–24
82	MVP/L150	Protocol Character Assignment – XON or ACK	8–25
83	MVP/L150	Protocol Character Assignment – XOFF or NAK	8–25
84	MVP/L150	Protocol Character Assignment – ETX	8–25
85–89	All	Reserved for Future Serial Interface Options	
90–99	All	Reserved for Future Options	

Option 60 — Data Line 8 with Parallel Interface

MVP/L150

Option 60 allows the use of parallel interface Data Line 8 to select the Alternate Font PROM or for paper instruction (PI).

Option Number	Display	Configuration Description
.0	60.0	Disable or not used (default).
.1	60.1	Enable Data Line 8 to select alternate font.
.2	60.2	Enable Data Line 8 for paper instruction.

150B/L150B

Option Number	Display	Configuration Description
.0	60.0	Disable Data Line 8.
.1	60.1	Enable Data Line 8 (allows access to characters (128–255)).

Option 61 — Paper Instruction with Parallel Interface

MVP/L150

The paper instruction (PI) is normally not used but may be enabled for use in controlling the EVFU.

Option Number	Display	Configuration Description
.0	61.0	Disable or not used (default).
.1	61.1	Enable use of paper instruction line for EVFU control.

150B/L150B

Option Number	Display	Configuration Description
.0	61.0	Disable (default).
.1	61.1	Enable use of paper instruction line for EVFU control.

Option 62 — Data Strobe Line Polarity with Parallel Interface

MVP/L150

Data Strobe is normally a low active (negative true) signal but may be configured to be high active (positive true).

Option Number	Display	Configuration Description
.0	62.0	Enable negative data strobe line polarity transition (default).
.1	62.1	Enable positive data strobe line polarity transition.

150B/L150B

Option Number	Display	Configuration Description
.0	62.0	Enable negative data strobe line polarity transition (default).
.1	62.1	Enable positive data strobe line polarity transition.

Option 63 — Data Lines and Response Line Logic Polarity with Parallel Interface

MVP/L150

Lines in Option 63 are normally high active (positive true) but they may be configured to low active (negative true) signals; Selected/Online, PE, and Data Request are affected. Acknowledge, used in the Centronics interface, remains low active.

Option Number	Display	Configuration Description
.0	63.0	Enable high active data and responsive lines logic polarity (default).
.1	63.1	Enable low active data and responsive lines logic polarity.

NOTE: Option 64 is reserved for future use.

150B/L150B

Option Number	Display	Configuration Description
.0	63.0	Enable high active data and responsive lines logic polarity (default).
.1	63.1	Enable low active data and responsive lines logic polarity.

Option 65 — Busy Line

MVP/L150

A high active busy line normally indicates the printer cannot receive data (the printer is advancing paper or is offline). The configuration may be set for active busy with any print line terminator including CR=0 line feeds.

Option Number	Display	Configuration Description
.0	65.0	Enable character by character handshake mode using busy (default).
.1	65.1	Enable active Busy with print line terminator control code.

150B/L150B

Option 65 must be set to 65.0.

Option 66 — Parallel Interface Selection

MVP/L150

The default sets the Centronics interface; however, this option also may be set for the Dataproducts interface.

Option Number	Display	Configuration Description
.0	66.0	Enable Centronics compatible parallel interface (default).
.1	66.1	Enable Dataproducts compatible parallel interface.

150B/L150B

Option Number	Display	Configuration Description
.0	66.0	Enable Centronics compatible parallel interface (default).
.1	66.1	Enable Dataproducts compatible parallel interface.

Option 70 — Serial Interface/ Protocol Selection

Two fundamental protocols, basic RS-232 and current loop are available for transferring data across the interface. Three character-oriented protocols can be used in combination with the fundamental protocols: XON/XOFF, ACK/NAK, and ETX/ACK.

Option Number	Display	Configuration Description
.0	70.0	RS-232-Basic (default)
.1	70.1	RS-232 with XON/XOFF Protocol
.2	70.2	RS-232 with ETX/ACK Protocol
.3	70.3	RS-232 with ACK/NAK Protocol
.4	70.4	Current loop – busy open loop
.5	70.5	Current loop – busy closed loop
.6	70.6	Current loop with XON/XOFF Protocol
.7	70.7	Current loop with ETX/ACK Protocol
.8	70.8	Current loop with ACK/NAK Protocol

Option 71 — Serial Data Transfer and Baud Rate

Ten selectable baud rates for transferring data across the interface are possible. Nine are generated within the system, while the tenth can be implemented external to the system. Although ordinary RS-232 transmission can be done at all available rates, do not use current loop at rates exceeding 4800.

Option Number	Display	Configuration Description
.0	71.0	9600 Baud (1 stop bit) or not used if RS-232 not installed (default).
.1	71.1	110 (2 stop bits).
.2	71.2	150 (1 stop bit).
.3	71.3	300 (1 stop bit).
.4	71.4	600 (1 stop bit).
.5	71.5	1200 (1 stop bit).
.6	71.6	2400 (1 stop bit).
.7	71.7	4800 (1 stop bit).
.8	71.8	19200 (1 stop bit).
.9	71.9	External (1 stop bit).

NOTE: Stop bits apply only to printer transmitted data.

Option 72 — Data Word Interface Configuration

Serial data bytes are transferred in a format that consists of a single start bit followed by 7 or 8 data bits, one parity bit, and 1 or 2 stop bits. The basic data word is 7 bits long. If the 8th bit is used, it can be used either to choose between the Primary Font PROM or the Alternate Font PROM on the Serial Controller PCBA, or to identify a Paper Instruction (PI) for the EVFU. The 8th bit can also be ignored. The parity bit is used for either even parity or odd parity or it can be ignored. Any parity error detected by the printer will cause a question mark (?) to be printed for that character.

Option Number	Display	Configuration Description
.0	72.0	Enable 7 bit data word – no parity check (default).
.1	72.1	Enable 7 bit data word with even parity check.
.2	72.2	Enable 7 bit data word with odd parity check.
.3	72.3	Enable 8th bit as data bit for font selection – no parity check.
.4	72.4	Enable 8th bit as data bit for font selection with even parity check.
.5	72.5	Enable 8th bit as data bit for font selection with odd parity check.
.6	72.6	Enable 8th bit as paper instruction – no parity check.
.7	72.7	Enable 8th bit as paper instruction with even parity check.
.8	72.8	Enable 8th bit as paper instruction with odd parity check.
.9	72.9	Ignore 8th bit – no parity check.

Option 73 — Transmitted Data Polarity

Logic polarity is normally positive true, but can be reconfigured to be negative true.

Option Number	Display	Configuration Description
.0	73.0	Enable normal logic (default).
.1	73.1	Enable interverted polarity logic.

Option 74 — Request to Send (RTS)

Interface line pin 4 can be made true when the printer status is :

ONLINE AND BUFFER ALMOST EMPTY (READY)

OFFLINE OR BUFFER ALMOST FULL (BUSY)

ONLINE (NO REGARD FOR BAE)

Option Number	Display	Configuration Description
.0	74.0	Enable ON condition when printer is online and buffer is not full (Ready) (default).
.1	74.1	Enable ON condition when printer is offline or buffer is full (Busy).
.2	74.2	Enable ON condition when printer is online.
.3	74.3	Enable always ON.
.4	74.4	Enable always OFF.

Option 75 — Clear to Send (CTS) and Carrier Detect (CD)

Two interface lines normally ignored by the printer. When a modem is used, they are configured to avoid being ignored. CTS (pin 5) informs the printer that the host computer is ready to receive data. CD (pin 8) allows the printer to send data.

Option Number	Display	Configuration Description
.0	75.0	Disable (default).
.1	75.1	Enable – (CTS must be ON for data transmission from the printer and CD must be ON for printer to receive data.

Option 76 — Data Set Ready (DSR–RS–232 pin 6)

Interface line pin 6 is normally ignored by the printer. When configured to *not to be ignored*, the printer firmware must verify that this interface line is true before the printer accepts the data.

Option Number	Display	Configuration Description
.0	76.0	Disable (default).
.1	76.1	Enable (DSR must be ON for printer to receive data).

Option 77 — Reverse Channel (RC)

The Reverse Channel Interface line (pins 11 and 14) is disabled by default.

The RC interface line can be made high true when the printer status is:

ONLINE AND BUFFER ALMOST EMPTY (READY)

OFFLINE OR BUFFER ALMOST FULL (BUSY)

Option Number	Display	Configuration Description
.0	77.0	Disable (default).
.1	77.1	Enable ON condition when printer is online and buffer is not full (Ready).
.2	77.2	Enable ON condition when printer is offline or buffer is full (Busy).
.3	77.3	Enable low ON (true) when printer is offline and buffer is not full.

Option 78 — Data Terminal Ready (DTR)

Interface line pin 20 can be made true when the printer status is:

ONLINE AND BUFFER ALMOST EMPTY (READY)

OFFLINE OR BUFFER ALMOST FULL (BUSY)

In addition, the DTR interface line can be held always ON (true) or always OFF (false).

Option Number	Display	Configuration Description
.0	78.0	Enable ON condition when printer is online and buffer is not full (Ready) (default).
.1	78.1	Enable ON condition when printer is offline or buffer is full (Busy).
.2	78.2	Enable always ON.
.3	78.3	Enable always OFF.

Option 79 — XON Buffer Level Threshold

Allows a choice of two Buffer Almost Empty (BAE) thresholds.

Option Number	Display	Configuration Description
.0	79.0	0% of installed buffer (default).
.1	79.1	25% of installed buffer.

Option 80 — XOFF Buffer Level Threshold

Allows a choice of two Buffer Almost Full (BAF) thresholds.

Option Number	Display	Configuration Description
.0	80.0	75% of installed buffer (default).
.1	80.1	85% of installed buffer.

Option 81 — Current Loop Out

Disables the current loop or allows a choice between internal or external current source.

Option Number	Display	Configuration Description
.0	81.0	Disable (default).
.1	81.1	Enable Internal Current source (active).
.2	81.2	Enable External Current source (passive).

NOTE: The Configuration Option Format on the digital panel changes for Configuration Options 82 through 84. After first indicating the address selected (82, 83, or 84), the left digit changes to zero and the two right digits display a two digit decimal Configuration suffix.

82 — Protocol Character Assignment – XON or ACK

Defines the decimal code equivalent for XON or ACK. The default value is 17, but any two digit code between 00 and 99 may be used. Used in conjunction with Configuration Option 83.

Display	Configuration Description
82.17	XON or ACK (default).

83 — Protocol Character Assignment – XOFF or NAK

Defines the decimal code equivalent for XOFF or NAK. The default value is 19, but any two digit code between 00 and 99 may be used.

Display	Configuration Description
83.19	XOFF or NAK (default).

84 — Protocol Character Assignment – ETX

Defines the decimal code equivalent for ETX. The default value is 03, but any two digit code between 00 and 99 may be used.

Display	Configuration Description
84.03	ETX (default)

Switching Interfaces

As previously mentioned, switching from one interface to the other requires a simple change of the printer's input/output (I/O) cable, terminating resistors, and Configuration Option 66 (refer to Switching Interfaces in this chapter).

Interface Cables

The Centronics or Dataproducts interface cable must not exceed 40 feet in length and must allow the transmission of signals having standard TTL logic levels (0.0V to +0.5 low and +2.4V to +5.25V high). For minimum electrical noise, use shielded cable and ground the shield.

Terminating Resistors

The Centronics parallel interface requires that 1000-ohm resistor packs be installed at Parallel Controller PCBA coordinates 15 C and 18C as shown in Figure 8-5. Typical circuits using the resistors are shown in Figure 8-6.

The Dataproducts interface requires the 220-ohm resistor pack at coordinates 18C and a 330-ohm pack at coordinates 17C. A 1000-ohm pack is installed at location 15C.

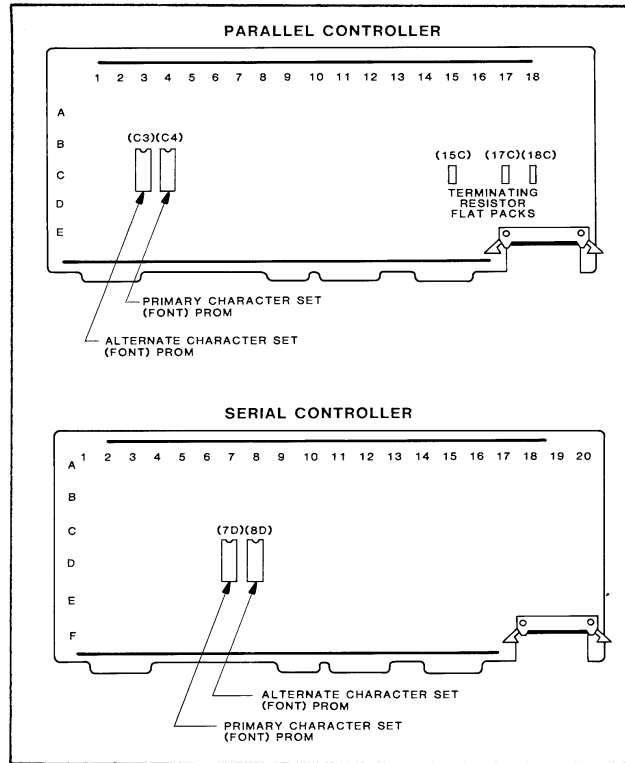

Figure 8-5. Controller PCBA

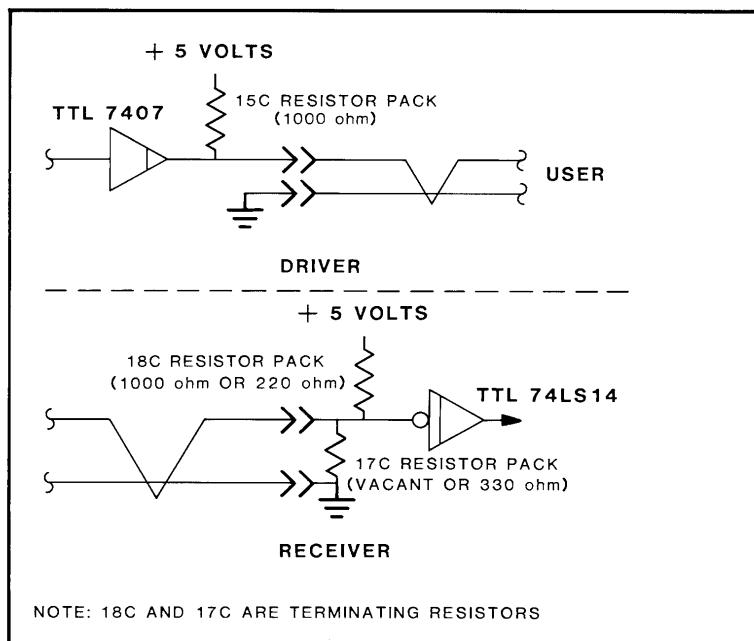

Figure 8-6. Interface Receiver and Driver Circuits

A

Character Sets and Control Codes

ASCII Character Set

KEY

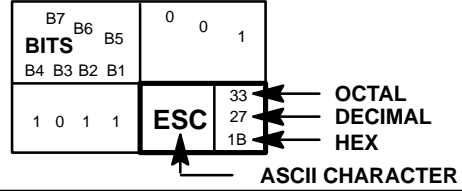

BITS		COLUMN		0		1		2		3		4		5		6		7					
B7	B6	B5	B4	B3	B2	B1	ROW																
0	0	0	0	0	0	0	0	NUL	0	DLE	20	SP	40	0	60	@	100	P	120	\	140	p	160
									0		16		32		48		64		80		96		112
									0		10		20		30		40		50		60		70
0	0	0	1	1	1	1	1	SOH	1	DC1 (XON)	21	!	41	1	61	A	101	Q	121	a	141	q	161
									1		17		33		49		65		81		97		113
									1		11		21		31		41		51		61		71
0	0	1	0	2	2	2	2	STX	2	DC2	22	"	42	2	62	B	102	R	122	b	142	r	162
									2		18		34		50		66		82		98		114
									2		12		22		32		42		52		62		72
0	0	1	1	3	3	3	3	ETX	3	DC3 (XOFF)	23	#	43	3	63	C	103	S	123	c	143	s	163
									3		19		35		51		67		83		99		115
									3		13		23		33		43		53		63		73
0	1	0	0	4	4	4	4	EOT	4	DC4	24	\$	44	4	64	D	104	T	124	d	144	t	164
									4		20		36		52		68		84		100		116
									4		14		24		34		44		54		64		74
0	1	0	1	5	5	5	5	ENQ	5	NAK	25	%	45	5	65	E	105	U	125	e	145	u	165
									5		21		37		53		69		85		101		117
									5		15		25		35		45		55		65		75
0	1	1	0	6	6	6	6	ACK	6	SYN	26	&	46	6	66	F	106	V	126	f	146	v	166
									6		22		38		54		70		86		102		118
									6		16		26		36		46		56		66		76
0	1	1	1	7	7	7	7	BEL	7	ETB	27	,	47	7	67	G	107	W	127	g	147	w	167
									7		23		39		55		71		87		103		119
									7		17		27		37		47		57		67		77
1	0	0	0	8	8	8	8	BS	8	CAN	30	(50	8	70	H	110	X	130	h	150	x	170
									8		24		40		56		72		88		104		120
									8		18		28		38		48		58		68		78
1	0	0	1	9	9	9	9	HT	9	EM	31)	51	9	71	I	111	Y	131	i	151	y	171
									9		25		41		57		73		89		105		121
									9		19		29		39		49		59		69		79
1	0	1	0	10	10	10	10	LF	10	SUB	32	*	52	:	72	J	112	Z	132	j	152	z	172
									10		26		42		58		74		90		106		122
									10		1A		2A		3A		4A		5A		6A		7A
1	0	1	1	11	11	11	11	VT	11	ESC	33	+	53	;	73	K	113	[133	k	153	{	173
									11		27		43		59		75		91		107		123
									11		1B		2B		3B		4B		5B		6B		7B
1	1	0	0	12	12	12	12	FF	12	FS	34	,	54	<	74	L	114	\	134	l	154		174
									12		28		44		60		76		92		108		124
									12		1C		2C		3C		4C		5C		6C		7C
1	1	0	1	13	13	13	13	CR	13	GS	35	-	55	=	75	M	115]	135	m	155	}	175
									13		29		45		61		77		93		109		125
									13		1D		2D		3D		4D		5D		6D		7D
1	1	1	0	14	14	14	14	SO	14	RS	36	.	56	>	76	N	116	^	136	n	156	~	176
									14		30		46		62		78		94		110		126
									14		1E		2E		3E		4E		5E		6E		7E
1	1	1	1	15	15	15	15	SI	15	US	37	/	57	?	77	O	117	_	137	o	157	DEL	177
									15		31		47		63		79		95		111		127
									15		1F		2F		3F		4F		5F		6F		7F

Extended Character Set

The following lists show the extended font character set. Note that Character 128 is available in Modes 1 and 6 only, or 1, 2, and 6 if the printer is equipped with V50.59 DCU and font PROM 116043-001 or equivalent.

0		32		64	e	96	`
1		33	!	65	A	97	a
2		34	"	66	B	98	b
3	♥	35	#	67	C	99	c
4	♦	36	\$	68	D	100	d
5	♣	37	%	69	E	101	e
6	♠	38	&	70	F	102	f
7		39	'	71	G	103	g
8		40	<	72	H	104	h
9		41	>	73	I	105	i
10		42	*	74	J	106	j
11		43	+	75	K	107	k
12		44	,	76	L	108	l
13		45	-	77	M	109	m
14		46	.	78	N	110	n
15		47	/	79	O	111	o
16		48	0	80	P	112	p
17		49	1	81	Q	113	q
18		50	2	82	R	114	r
19		51	3	83	S	115	s
20		52	4	84	T	116	t
21	§	53	5	85	U	117	u
22		54	6	86	V	118	v
23		55	7	87	W	119	w
24		56	8	88	X	120	x
25		57	9	89	Y	121	y
26		58	:	90	Z	122	z
27		59	;	91	[123	{
28		60	<	92	\	124	:
29		61	=	93]	125	}
30		62	>	94	^	126	~
31		63	?	95	_	127	

128	Ç	160	À	192	ˆ	224	α
129	Ù	161	Í	193	±	225	β
130	É	162	Ó	194	⌈	226	Γ
131	È	163	Ô	195	⌋	227	Π
132	Å	164	×	196	—	228	Σ
133	Ǽ	165	Ț	197	†	229	σ
134	Ǻ	166	Ş	198	‡	230	μ
135	Ç	167	Œ	199	‡	231	τ
136	È	168	Ɔ	200	ˆ	232	ϖ
137	È	169	Ɔ	201	Ɔ	233	θ
138	È	170	Ɔ	202	±	234	Ω
139	Ÿ	171	¼	203	⌈	235	δ
140	Ÿ	172	¼	204	⌋	236	θ
141	ı	173	ı	205	—	237	ø
142	Δ	174	«	206	†	238	ε
143	Δ	175	»	207	±	239	∩
144	É	176	▯	208	±	240	■
145	æ	177	■	209	⌈	241	±
146	Æ	178	▯	210	⌋	242	z
147	ø	179		211	ˆ	243	z
148	ø	180	†	212	ˆ	244	Ɔ
149	ø	181	†	213	Ɔ	245	J
150	ø	182	†	214	Ɔ	246	+
151	ø	183	Ɔ	215	†	247	z
152	ÿ	184	Ɔ	216	†	248	o
153	ø	185	†	217	Ɔ	249	.
154	ù	186		218	Ɔ	250	.
155	¢	187	Ɔ	219	■	251	√
156	£	188	Ɔ	220	■	252	n
157	¥	189	Ɔ	221	■	253	z
158	₹	190	Ɔ	222	■	254	.
159	f	191	Ɔ	223	■	255	

BS/CR Protocol

Protocol After Receiving a CR or BS Character*		
Old Character	New Character	Resulting Character
1. space	space	space
2. character	space	character
3. space	character	new character
4. character	underline	old char + UL
5. underline	character	new char + UL
6. character	character	new character
7. bit image	space	bit image
8. space	bit image	bit image
9. character	bit image	bit image
10. underline	bit image	bit image
11. bit image	character	character
Attributing Conditions		
1. normal	normal	normal
2. dbl wide (Conf. 20.1)	normal	normal
3. dbl strike	normal	normal
4. emp	normal	normal
5. normal	dbl wide (Conf. 20.1)	wide
6. normal	dbl strike	dbl strike
7. normal	emp	emp
8. not underlined	underlined	underlined
9. script	normal	normal
10. normal	script	script
11. super/subscript	sub/superscript	sub + super **

* If character following CR or BS matches character string before CR or BS, it will be printed in double strike to emulate second pass over print (bold).

** This feature enables subscript and superscript placement on the same character column.

ASCII Control Codes by Function

Print Width Commands

Control Code (ASCII)	Character Name	Dec Value CHR\$(n)
EOT	End of Text	(4)
ENQ	Enquire	(5)
DC2	DC2	(18)
DC4	DC4	(20)
SI	Shift In	(15)
SO	Shift Out	(14)
ESC P	Escape, "P"	(27) (80)
ESC R	Escape, "R"	(27) (82)
ESC V	Escape, "V"	(27) (86)
ESC W(n)	Escape, "W"	(27) (87) (n)
ESC Y	Escape, "Y"	(27) (89) (n1) (n2)
ESC Z	Escape, "Z"	(27) (90) (n1) (n2)
ESC n	Escape, "n"	(27) (110)
ESC r	Escape, "r"	(27) (114)
ESC M	Escape, "M"	
ESC [mq	Escape, "[mq"	

Print Quality Commands

Control Code (ASCII)	Character Name	Dec Value CHR\$(n)
ESC E	Escape, "E"	(27) (69)
ESC F	Escape, "F"	(27) (70)
ESC G	Escape, "G"	(27) (71)
ESC H	Escape, "H"	(27) (72)
ESC S (n)	Escape, "S" Dec. No. (1) n=0 or 48 (2) n=1 or 49	(27) (83) (n)
ESC T	Escape, "T"	(27) (84)
ESC SO	Escape, Shift Out	(27) (14)
ESC SI	Escape, Shift In	(27) (15)
ESC-n	Escape, minus Decimal Number	(27) (45) (n)
ESC -0	Escape, -0	
ESC -1	Escape, -1	
ESC -2	Escape, -2	
ESC -3	Escape, -3	

Selecting Print Modes

Control Code (ASCII)	Character Name	Dec Value CHR\$(n)
ESC @	Escape, "At"	(27) (64)
ESC I	Escape, "I"	(27) (73)
ESC h	Escape, "h"	(27) (104)
ESC CAN	Escape, Cancel	(27) (24)
ESC!	Escape, Exclamation	(27) (33)
ESC [Escape, "Left Bracket"	(27) (91)

Graphic Modes

Control Code (ASCII)	Character Name	Dec Value CHR\$(n)
ESC K	Escape, "K"	(27) (75)
ESC K (n1) (n2)	Escape, "K" Dec. No. 1 Dec. No. 2	(27) (75) (n1) (n2) (data)
ESC L (n1) (n2)	Escape, "L" Dec. No. 1 Dec. No. 2	(27) (76) (n1) (n2)
ESC*	Escape, "*"	(n1) (n2)

Special Printer Features

Control Code (ASCII)	Character Name	Dec Value CHR\$(n)
BS	Backspace	(8)
CAN	Cancel	(24)
DEL	Delete	(127)
ESC 6	Escape, Six	(27) (54)
ESC >	Escape, Greater Than	(27) (62)
ESC 7	Escape, Seven	(27) (55)
ESC =	Escape, Equal	(27) (61)
ESC#	Escape, Pound	(27) (35)

Forms Control Commands

Control Code (ASCII)	Character Name	Dec Value CHR\$(n)
CR	Carriage Return	(13)
FF	Form Feed	(12)
ESC C n	Escape, "C", Dec. No. 1–127.	(27) (67) (n)
ESC C 0 n	Escape, "C", "zero", number	(27) (67) (0) (n)
ESC N(n) 1 ≤ n ≤ 127	Escape, "N" Dec. No. 1–127	(27) (78) (n)
ESC O	Escape, "O"	(27) (79)
ESC 8	Escape, Eight	
ESC 9	Escape, Nine	

Paper Feed Commands

Control Code (ASCII)	Character Name	Dec Value CHR\$(n)
ESC A (n) (0 ≤ n ≤ 85)	Escape, "A", Dec. No. 0–85	(27) (65) (n)
LF	Line Feed	(10)
ESC 0	Escape, Zero	(27) (48)
ESC 1	Escape, One	(27) (49)
ESC 2	Escape, Two	(27) (50)
ESC 3(n) (0 ≤ n ≤ 255)	Escape, Three Decimal Number 0–255	(27) (51) (n)
ACK	ACK	(6)
ESC 3(n) (0 ≤ n ≤ 255)	Escape, Three Decimal Number 0–255	(27) (51) (n)
ESC J	Escape, "J"	(n)
ESC x	Escape, "x"	(n)

Formatting Commands

Control Code (ASCII)	Character Name	Dec Value CHR\$(n)
HT	Horizontal Tab	(9)
VT	Vertical Tab	(11)
ESC D	Escape, "D" n1, n2...	(27) (68) (n1) (n2)
NUL	NULL	(0) (255)
DLE	DLE	(16)
DC1	DC1	(17)
DC2	DC2	(18)
DC3	DC3	(19)
DC4	DC4	(20)
NAK	NAK	(21)
SYN	SYN	(22)
ETB	ETB	(23)
CAN	CAN	(24)
EM	EM	(25)
SUB	SUB	(26)
ESC	ESC	(27)
FS	FS	(28)
GS	GS	(29)
RS	RS	(30)
US	US	(31)

9

Routine Service and Diagnostics

Chapter Contents

Introduction	9-2
Cleaning Requirements	9-2
Before Cleaning	9-3
Cleaning the Printer	9-5
Moving the Printer	9-7
Reconnecting the Cables	9-8
Corrective Maintenance	9-9
Self-Tests	9-10
Self-Test Procedure	9-10
Self-Test Configuration	9-12

Introduction

The MVP-Series printers require little maintenance beyond general cleaning. However, to avoid maintenance problems, periodically remove excess paper chaff, and dust from the ribbon and paper paths. Be aware that there will be times when it will be necessary to determine whether a service call is necessary. In these instances, refer to the “Corrective Maintenance” section of this chapter for information on how to locate and diagnose printer problems. If you are unable to locate the problem even after cleaning, contact your authorized service representative.

Cleaning Requirements

Periodic cleaning ensures efficient operation and clear print quality. Clean the printer every three months or after every 250 hours of operation, whichever occurs first. If the printer is located in a dusty area or is used for heavy duty printing, clean it more often. Any service other than periodic cleaning must be done only by an authorized service representative.

– **WARNING** –

Unplug the printer before cleaning the printer.

General External Cleaning

Clean the outside of the cabinet with a soft, lint-free cloth and mild detergent soap. (Dishwashing liquid works well.) Do not use abrasive powders or chemical solvents. Clean the windows with plain water or mild window cleaner. Always apply the cleaning solution to the cloth; never pour cleaning solution directly onto the printer.

General Internal Cleaning

Over time, particles of paper and ink accumulate inside impact printers. This is normal. Paper dust and ink build-up must be periodically removed to avoid degraded print quality. Most paper dust accumulates around the ends of the platen and ribbon path.

Before Cleaning

Before cleaning the printer, turn the printer off and unplug the power cord. Unload the paper (page 3–12), and perform the following steps. (refer to the maintenance manual for further assistance).

NOTE: If you must move the printer, follow instructions in the next section on Moving the Printer.

1. Fully raise the forms thickness adjustment lever.

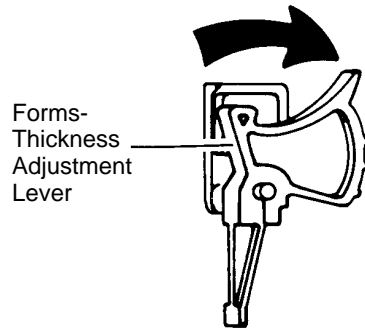

2. Unlatch both ribbon spools, and carefully lift them off the hub. Raise the ribbon out of the ribbon path.

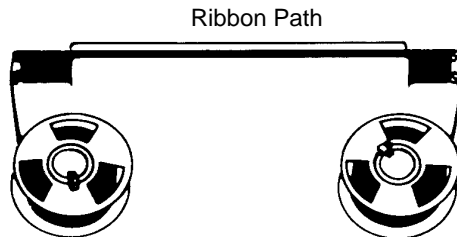

3. Remove the shuttle cover by grasping the cover on both sides. Lift it up at the rear, while gently sliding it backward and off the shuttle.

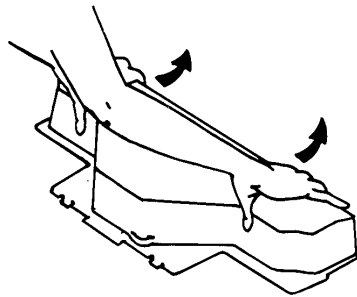

4. Remove the hammer bank assembly cover as follows:
 - a. Lift and hold the shuttle locking knob as far as it will go.

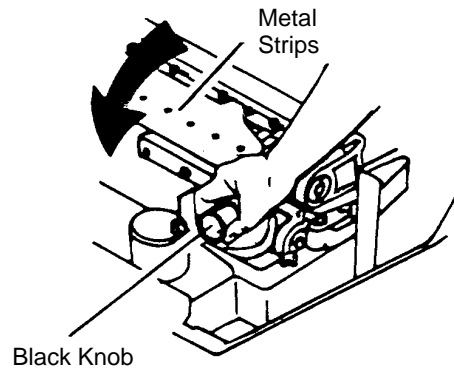

- b. Grasp the hammer bank cover assembly carefully and tilt it up from the front, away from you.

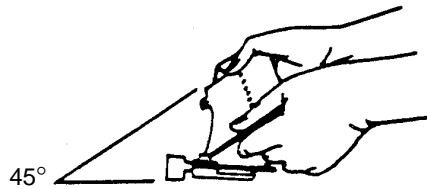

- c. Pull the cover assembly upward so that it clears the small retaining pins of the hammer tips; pull the cover assembly clear from the magnets.

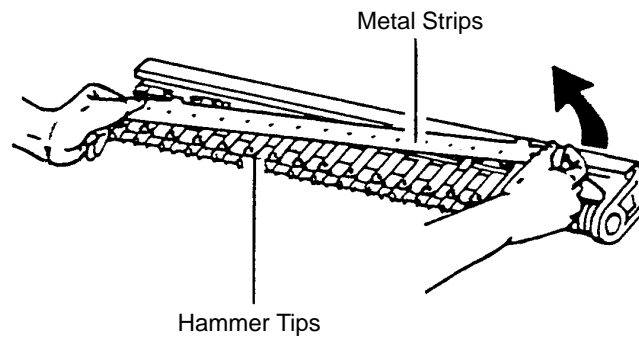

Cleaning the Printer

1. Using a soft-bristled brush and nonmetallic vacuum cleaner extension tool, brush and vacuum paper and dust particles from the paper path, ribbon guides, ribbon path, and base pan.

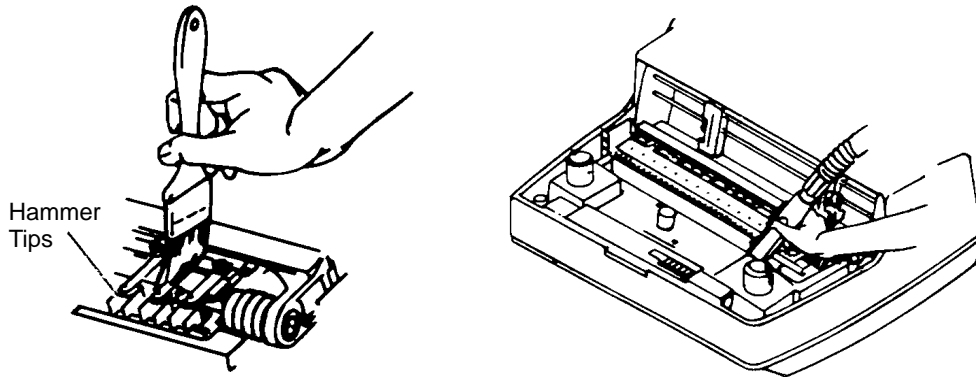

2. Check the ribbon mask and hammer tips cover for bits of torn paper ribbon lint and ribbon ink build-up. Check the holes in the ribbon mask surrounding each hammer tip. Gently remove paper or lint particles with a wooden stick or pair of tweezers. (Do not pry or apply force to the hammer tips.)

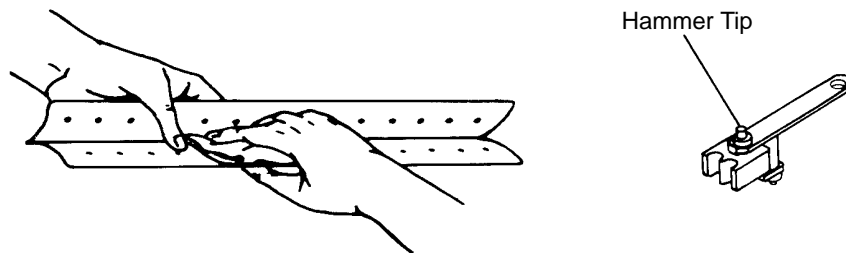

- Using a soft cloth lightly moistened with denatured alcohol, remove dust and ink from the platen. (The platen is the thick silver bar behind the hammer bank cover that rotates when the forms thickness adjustment lever is rotated.)

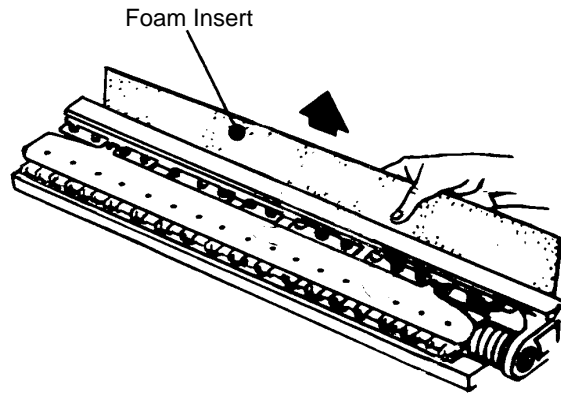

- Brush and vacuum dust or residue that has accumulated inside the lower cabinet.
- Wipe the lower cabinet interior with a clean, lint-free cloth dampened (not wet) with water and mild detergent, or spray the surfaces lightly with window cleaning solution. Dry the lower cabinet interior by wiping it with a clean, lint-free cloth.
- When necessary, clear the ventilation slots at the back of the printer, ensuring that they are not blocked by any objects such as drapes, books, paper, etc. Blocked ventilation slots can cause overheating and adversely affect operating efficiency.
- Replace the hammer bank assembly cover, shuttle cover and ribbon by reversing the instructions on page 9-3.

Moving the Printer

Perform the following steps to move the printer.

1. Disconnect the power cord and I/O interface at both ends.
2. Unload the paper (refer to page 3–12).
3. Remove the ribbon spools, and shuttle cover (refer to page 9–3).
4. Remove the two transport restraining screws from their storage receptacles and screw them into the shuttle assembly as follows:
 - a. Insert the left screw first and hand tighten it.
 - b. Insert the right screw and hand tighten it. When properly inserted and tightened, the screws keep the shuttle rigid and prevent damage when the printer is moved or shipped.

CAUTION

When moving the printer, always secure the shuttle assembly with the transport restraining screws to prevent damage to the print mechanism.

5. Replace the shuttle cover by reversing the instructions on page 9–3.

NOTE: Ensure that the printer is level at its new location, then remove the shuttle cover.

6. Remove the transport restraining bolt.
7. Replace the shuttle cover and ribbon.
8. Reconnect the I/O interface cable. Connect power cord after checking the AC line voltage.

Reconnecting the Cables

Perform the following instructions to connect the cables to the printer.

1. Verify that the voltage shown on the printer ID label is within the same range as the site line voltage, and that the proper power cord has been selected. (Refer to “Applying Power” on page 2–5.)
2. Make sure the printer power switch is set to OFF (0).
3. Connect the power cord between the printer’s AC power connector and the AC line receptacle.
4. Connect the interface cable (customer supplied) between the appropriate printer interface connector and the host computer. (Refer to Chapter 8 for a complete description of connecting the interfaces.)

Corrective Maintenance

When the printer malfunctions, you will have to determine whether a service call is necessary. In these instances, there are several measures you can take before making the call. Electronic, mechanical and system are three major areas that you can check, and possibly repair, when determining where and what the problem is.

Simple electronic problems can sometimes be repaired because the operator's panel displays error codes that refer to specific corrective actions. To learn these error codes, refer to Appendix B for complete descriptions. Mechanical problems, however, are somewhat harder to diagnose. Therefore, check the following problem areas in Table 9-1. System problems can be detected by running the self-tests (see the "Self-Tests" section on page 9-10).

Table 9-1. Mechanical Problems

Problem Area	Corrective Action
Noisy Shuttle Action	Continue to use the printer until the printer is serviced (unless the print quality becomes unusable).
Erratic or Stalled Shuttle	<ol style="list-style-type: none"> (1) Make sure the transport restraining bolts are removed. (2) Remove any jammed paper and reload the paper. (3) Make sure the ribbon is not folded or misfed. Replace it if necessary. (4) Clean the printer thoroughly as explained on page 9-5. (5) Call for service if the problem persists.
Paper Transport Feeds Improperly	<ol style="list-style-type: none"> (1) Remove any jammed paper and reload the paper. (2) Run the Paper Motion Tests (06.1) see page 9-16. (3) Call for service if the problem persists.
Ribbon Transport Feeds Improperly	<ol style="list-style-type: none"> (1) Replace the ribbon if a) it is worn, torn or perforated, b) it does not run smoothly through the guides, or c) it does not reverse direction at both ends of its spool. (2) Clean the printer thoroughly as explained on page 9-5. (3) Call for service if the problem persists.
Poor Print Quality	<ol style="list-style-type: none"> (1) Check that the Forms Adjustment Thickness Lever is at its appropriate setting. (2) Replace the ribbon if a) it is worn, torn or perforated. (3) Clean the printer thoroughly as explained on page 9-5. (4) Replace the font PROM if the printer consistently misplaces dots. (5) Broken or misaligned hammers require a service call.

Self-Tests

There are twenty printer self-tests you can use to determine configuration, evaluate print quality, and check paper motion. Self-tests are divided into six general types: Configuration, Automatic Sequence, Repeating, Print, Paper Motion and Hex Dump. A detailed explanation of the six types of self-tests and the procedures to initiate a test are contained in the following paragraphs. All tests are listed in Table 9-2. Always use full size computer paper in the printer when running any of the self-tests.

Self-Test Procedure

1. Lift the printer cover. Make sure the RDY indicator is flashing.

NOTE: Always use full size computer paper when running the self-tests or else you may harm the platen.

2. Press and release the 2nd FUNC switch.
3. Press and release the ADDR switch; the switch indicator will stay on steadily. The digital panel will display two digits: the last code used or "00.0".
4. Select a self-test from Table 9-2.
5. Press and release the ADDR switch until the digital panel displays the first two digits of the test selected. (If pass the number, press and hold the ADDR switch. The digits will advance to 99, then begin at 00 or refer to the configuration chapter for an alternative method that reverses the count direction.)
6. Press and release the DATA switch (advances .1 each time) until the desired third digit (decimal) is displayed.
7. Press and release 2nd FUNC switch to start printing.
8. Press and release RDY switch to stop printing.

NOTE: If the RDY indicator flashes at the end of the test, the test was successfully completed.

Table 9–2. Self–Tests

ADDR/Data Switches	Configuration	Page #
00.1	Configuration printout including part numbers of each installed PROM and font	9–12
00.2	Primary and alternate font – printout of each installed character set including PROM part numbers	9–12
Automatic Sequence		
01.1	(MVP/L150) Continuous sequence of test patterns 05.1, 05.2 and 06.1 (150B/L150B) 02.1, 02.2, 02.3, 02.4, 03.1, 03.2, 03.3, 03.4, 05.1, 05.2, 06.1	9–13
Repeating Tests		
02.1	All E repeating	9–14
02.2	All H repeating	
02.3	All # repeating	
02.4	All _ (Underline) repeating	
03.1	Shift recycle repeating	
03.2	Row increment repeating (64 characters set) (150B only)	
03.3	All black plot, half speed, repeating	
03.4	64 characters set, underlined repeating (150B only)	
Print Tests		
05.1	Shift recycle, full character set	9–15
05.2	Double High 16 lines	
Paper Motion Test		
06.1	Top–of–Form, slews, and prints one line six times <i>NOTE: 12.1 through 14.0 are used by service technicians.</i>	9–16
Hex Dump Mode		
15.0*	Hex dump mode disable (default)	9–17
15.2*	Flush last hex dump text line	
16.0*	Reconfiguration disable (default) – Lock/unlock feature (150B only) (page 4–4)	
16.3	Reconfiguration enable – Lock/unlock feature (150B only) (page 4–4)	
16.4	Accidental Reconfiguration enable (page 4–4)	
22.0	Self–Test 80 column print (default) (refer to page 4–11)	
22.1	Self–Test 132 column print (150B only) (refer to page 4–11)	
<i>*NOTE: 16.3 must be set to enable access to these options.</i>		

Configuration Self-Test

Two configuration self-tests (00.1 and 00.2) produce the printer configuration options and additional information. Test 00.1 prints the configuration setting of Configuration Options 20 through 99 and the part number of each PROM installed. Figure 9-1 shows a sample configuration printout for a standard L150 controller configured for use with the optional IGP-20.

Configuration Test 00.2 prints each installed character set including the character font part number.

```
Configuration:
20. 1  21. 0  22. 1  23. 0  24. 0  25. 0  26. 1  27. 0  28. 0  29. 0
30. 0  31. 0  32. 0  33. 0  34. 0  35. 0  36. 0  37. 0  38. 0  39. 0
40. 0  41. 0  42. 0  43. 0  44. 0  45. C  46. 8  47. 1  48. 0  49. 0
50. 1  51. 0  52. 0  53. 0  54. 0  55. 0  56. 0  57. 0  58. 0  59. 0
60. 1  61. 0  62. 0  63. 0  64. 0  65. 0  66. 0  67. 0  68. 0  69. 0
70. 0  71. 0  72. F  73. 0  74. 0  75. 0  76. 0  77. 0  78. 0  79. 0
80. 0  81. 0  82. 0  83. 0  84. 0  85. 0  86. 0  87. 0  88. 0  89. 0
90. 0  91. 0  92. 0  93. 0  94. 0  95. 0  96. 0  97. 0  98. 0  99. 0

Part Numbers :
Dcu150B : 117111-001 Ver 50.59 D.C. 8417
Mcu      : 117104-001 Ver 20.24 D.C. 8417
Pri Font : 116043-001 Ver 10.00 D.C. 8417
Alt Font : 116021-001 Ver 10.00 D.C. 8313
```

Figure 9-1. Configuration Printout (Sample)

NOTE: Configuration data is stored in a non-volatile memory called an EAROM. A configuration printout immediately following power-up always reflects EAROM-stored values. Some printer option codes may reflect values set by the host computer after printer operation because they can be dynamically changed during operation. These are: 30.X, print mode; 50.X, skip over perf; 51.X, lines per inch; and 52.X, forms length. (Stored value for all four configurations is not modified.)

Automatic Sequence

MVP/L150

On a standard MVP or L150 printer, the Automatic Sequence Test (01.1) runs a continuous sequence of two print tests (05.1 and 05.2) and one paper motion test (06.1). The two print tests and the paper motion test can also be selected individually.

150B/L150B

On the 150B or L150B printer, the Automatic Sequence Test (01.1) runs one complete sequence of test patterns 2.1 through 6.1.

Repeating

Repeating Tests

Repeating tests E (02.1), H (02.2), # (02.3) and Underline (02.4) print the character in every character position across the full width of the paper.

Shift Recycle

Shift Recycle (03.1) prints the character set (uppercase only) across the width of the paper. The order of the characters remains the same from line to line but all characters shift one character position to the left for each line.

All Black Plot

All Black Plot (03.3) is a solid pattern of black dots across the full width of the page. Printing is done continuously, but at half speed.

Print

Shift Recycle

Shift Recycle Full Character Set (05.1) prints the full character set across the width of the paper. The order of the characters remains the same from line to line but all characters shift one character position to the left for each line.

Double High (05.2) prints 16 lines of elongated characters.

Paper Motion

The Paper Motion Test (06.1) completes a top-of-form operation, slews paper, and prints one line of characters a total of six times.

Mode Changing Examples

M = mode

1 = WP, 10 cpi

2 = DPI, 10 cpi

3 = Compressed, 12.5 cpi

5 = Condensed, 16.7 cpi

Example 1

1. Power-up mode = M2 (Configuration 30.0)

- M2 + ESC SO, SO = M6, one line only, then M2
- M2 + ESC W1 = M6
- M2 + ESC W1 + ESC SI, SI = M2
- M2 + ESC SO, SO + ESC SI, SI = M2 one line, then M5
- M2 + ESC WO = M2
- M5 + DC2 = M2
- M2 + ESC P = M1

Example 2

2. Power-up mode = M2 (Configuration 30.4)

- M5 + ESC SO, SO = M2, one line, then M5
- M5 + ESC W1 = M2
- M5 + DC2 = M5 (Clears to M5)

Example 3

3. Power-up mode = M2 (Configuration 30.2)

- M3 + ESC SO, SO = M3
- M3 + ESC SI, SI = M5
- M3 + ESC SI, SI = ESC SO, SO = M2

Hex Dump Mode

A system problem can be detected by a process of elimination. Run the self-tests beginning with 01.1, by using the procedure on page 9–10. If the RDY indicator flashes at the end of the test, the test was successful. If, however, the RDY indicator does not flash, use one of the Hex dump modes to help you decode the system interface problem.

To initiate a Hex Dump, do the following:

1. Set Configuration Option 15 to 15.1.

NOTE: Configuration Option 16.3 must be set to enable the Hex dump.

2. Press RDY to place the printer on-line. The RDY indicator should remain lit.
3. Send data from the host computer; a Hex dump printout will list each ASCII character with its corresponding Hex code value. Non-printable ASCII characters should also have a corresponding Hex code, including carriage returns and line feeds. If the Hex dump does not print or is not accurate, interface problems could exist.
4. To disable the Hex dump, return Configuration Option 15.1 to 15.0 or cycle the printer power.

B Printer Diagnostics

MVP-Series printers sense printer faults and signal these faults with a lit CHK indicator and codes in the panel display. Table B-1 lists the fault codes and required actions. Some faults cannot be cleared or bypassed. In such cases, contact a qualified service representative to perform the repairs. Refer to the appropriate maintenance manual for supplemental tests.

Printer Fault Conditions

A steady or flashing CHK indicator signals a fault in the printer which must be corrected or bypassed before the printer can be placed on-line.

When a fault condition occurs, check for one of three situations:

- Flashing CHK indicator, which means the fault is user correctable.
- Steady CHK indicator, which means the fault is not user-correctable. Some non-correctable faults are soft faults (that is, a memory checksum or pattern check) that can be bypassed (see “Bypass Soft Fault”).
- A three-digit code in the display panel, which identifies the fault code (see Table B-1).

To Bypass Soft Fault

To bypass a soft fault:

1. Press and hold the CHK switch.
2. Press and quickly release the RDY switch.
3. Release the CHK switch.

Table B-1. Fault Code Chart

Check Indicator	Fault Code	Fault Description	Corrective Action
Flashing	011	No paper	Load paper
Flashing	012	Forms thickness lever open; shuttle assembly cover off or out of place.	Close lever; replace or reseal shuttle cover.
Flashing	014	Shuttle jam	Remove jammed paper or straighten ribbon.
Flashing	015	Shuttle not up to speed	Remove any jammed paper; straighten ribbon; or check that forms thickness lever is in correct position.
Steady	030 031 032 040 033 041 050 051	Printer memory: checksum or pattern check. These are "soft" faults.	None, but can be bypassed. Keep a log of these codes and when they occur for your field service representative.
Steady	060	Power supply: +30/+12 voltage failure	None. Call an authorized service representative.
Steady	061	Power supply: -16/-12 voltage failure	None. Call an authorized service representative.
All switch indicators On or Off	None	Data processor malfunction	None. Call an authorized service representative.

Clear Check Condition

After all faults are corrected:

1. Press CHK to clear the fault condition (CHK indicator will go out).
2. If applicable, press RDY to place the printer on-line.

C

Specifications, Accessories and Options

This Appendix consists of the specifications, accessories and options for the Standard MVP, L150 and 150B/L150B printers.

Printer Performance

MVP	High Density Font	Data Processing	Compressed Print	High Speed Bar Code	Condensed Print
DOT DENSITY (dots/in) (horz x vert)	100 x 96	60 x 72	62.5 x 64	50 x 48	100 x 72
with Density Option	100 x 100	60 x 75	62.5 x 66.7	50 x 50	100 x 72
PRINT RATE (lines/min)					
Uppercase	80	150	200	250	100
Underline or descenders	62	120	N/A	N/A	N/A
Double Height characters	44	85	120	N/A	N/A
PLOT RATE (in/min)	8.3	16.7	18.7	27.8	10.0
PLOT RESOLUTION (dots/in)	200 x 96	120 x 72	125 x 64	100 x 48	200 x 72
with Density Option	200 x 100	120 x 75	125 x 66.7	100 x 50	200 x 75
PAPER SLEW RATE	8 IPS	8 IPS	8 IPS	8 IPS	8 IPS

L150	High Density Font	Data Processing	Compressed Print	High Speed Bar Code	Condensed Print
CHARACTER PITCH	10.0	10.0	12.5	12.1	13.3
DOT DENSITY (dots/in) (horz x vert)	100 x 96	60 x 72	62.5 x 64	72.5 x 72	80 x 72
PRINT RATE (lines/min)					
Uppercase	80	150	200	125	120
Underline or descenders	62	120	N/A	99	106
Double Height characters	44	85	120	70	66
PLOT RATE (in/min)	8.3	16.7	18.7	13.8	13.0
PLOT RESOLUTION (dots/in)	200 x 96	120 x 72	125 x 64	145 x 72	160 x 72
PAPER SLEW RATE	8 IPS	8 IPS	8 IPS	8 IPS	8 IPS

150B	High Density Font	Data Processing	Compressed Print	High Speed Bar Code	Condensed Print	Expanded Print
DOT DENSITY (dots/in) (horz x vert)	100 x 96	60 x 72	62.5 x 64	50 x 48	100 x 72	50 x 96
PRINT RATE (lines/min)						
Uppercase	80	150	180	N/A	100	125
Underline or descenders	62	120	N/A	N/A	77.5	100
Double Height characters	47	92	117.5	N/A	58.8	76.7
PLOT RATE (in/min)	8.3	16.7	18.7	27.8	10.4	13.9
PLOT RESOLUTION (dots/in)	200 x 96	120 x 72	125 x 64	100 x 48	200 x 72	100 x 96
PAPER SLEW RATE	8 inches per second for all modes					

Print Format

MVP	High Density Font	Data Processing	Compressed Print	High Speed Bar Code	Condensed Print
FONT MATRIX Uppercase (horz x vert)	7(13) x 9 + 3	5(9) x 7 + 2	4 (7) x 5 + 0	N/A	5(9) x 7 + 2
VERTICAL FORMAT (lines/in)	6, 8	6, 8, (9 or 10)	6, 8, (9 or 10)		6, 8
ASCII CHARACTER SET	96	96	64	64	96
EXTENSION with ALTERNATE FONT PROM	Up to 128 additional characters for each print mode.				

NOTE: The FONT MATRIX specification is read as: Seven overlapping dots print in the horizontal plane on 13 vertical centers. Uppercase characters form by nine vertical dots and lowercase characters from by 12 (nine plus three descenders).

L150	High Density Font	Data Processing	Compressed Print	High Speed Bar Code	Condensed Print
FONT MATRIX Uppercase (horz x vert)	7(13) x 9	5(9) x 7	4 (7) x 5	5(9) x 7	5(9) x 7
Lowercase	7(13) x 12	5(9) x 9	N/A	5(9) x 9	5(9) x 9
VERTICAL FORMAT (lines/in)	6, 8	6, 8, (9 or 10)	6, 8, (9 or 10)	6, 8, (9 or 10)	6, 8
ASCII CHARACTER SET	96	96	64	96	96
EXTENSION with ALTERNATE FONT PROM	Up to 128 additional characters for each print mode.				
BAR CODE DENSITY					
Code 3/9	—	—	—	4.5 cpi (3:1) 5.5 cpi (2:1)	—
Code 128B	—	—	—	6.6 cpi	—
Code 128C	—	—	—	13.2 cpi	—
EAN 8	—	—	—	—	0.96 mag.
EAN 13	—	—	—	—	0.96 mag.
INTERLEAVED 2/5	—	—	—	8.1 cpi	—
UPC-A	—	—	—	—	0.96 mag.

NOTE: Refer to the NOTE above for details on the FONT MATRIX specification.

L150B	High Density Font	Data Processing	Compressed Print	High Speed Bar Code	Condensed Print	Expanded Print
FONT MATRIX						
Uppercase (horz/vert)	7(13) x 9	5(9) x 7	4(7) x 5	N/A	5(9) x 7	7(13) x 9
Lowercase	7(13) x 12	5(9) x 9	N/A	N/A	5(9) x 9	7(13) x 12
HORIZONTAL FORMAT						
Characters/Line	132	132	170	N/A	220	40
Pitch (chars/in)	10	10	12.5	N/A	16.7/17.5	5
VERTICAL FORMAT (lines/in)						
Character Set ASCII	6, 8, 9, 10	6, 8, 9, 10	6, 8, 9, 10	N/A	6, 8, 9, 10	6, 8, 9, 10
	224	224	64	N/A	224	224

NOTE: Mode 6 is operable only if configuration 20.0 is selected.

Paper and Ribbon Guidelines

Guidelines	Characteristics/Function
<p>Paper</p> <p>Feed</p> <p>Forms</p> <p>Size</p> <p>Weight</p> <p>Labels</p>	<p>(For 150B: Adjustable horizontally or vertically; 600 steps per inch resolution.)</p> <p>Continuous, fanfold, 1 to 6 part, edge perforated, no hard material. (For 150B: Vertically adjustable position control; pushbutton line feed and top-of-form; programmable perforation skipover; selectable forms length in 1/2 inch intervals.)</p> <p>3 to 16 wide, 3 to 24 in. wide</p> <p>Maximum 15 to 100 lb. stock.</p> <p>One part, continuous perforated fanfold backing form; 3 to 16 in. wide (including the two standard perforated tractor feed strips), and 3 to 24 in. long between top and bottom perforations.</p> <p>The maximum thickness (including backing) is 0.025.</p> <p>Labels must be placed at least 1/16 in. from the fanfold perforation. Do not use labels that have excessive adhesive that can be squeezed out during printing.</p>
<p>Ribbon</p> <p>Type</p>	<p>Nylon fabric, spool to spool, one inch wide by 60 yards long; Printronix P/N 102247 (Standard), P/N 102796 (OCR).</p>

Electrical, Physical, Environmental and Product Certification

Specifications	Characteristics/Function	
Electrical*	North American	International
Voltage	120 (+10%, -30%) Vac single phase	120 (+10%, -30%) Vac or 240 (+10%, -30%) Vac single phase
Frequency	47 to 62 Hz.	47 to 62 Hz.
Input Voltage	120 Vac nominal	120 Vac nominal; 240 Vac Nominal
Current (rms)	4 amps maximum	4 amps maximum; 2 amps maximum
Power Factor	0.65 nominal	0.65 nominal; 0.65 nominal
120/240 Vac	Factory installed for 120 Vac or 240 Vac operation; power consumption same as international model.	
	<i>*The electrical specifications apply to all three printers in the MVP-Series.</i>	
Physical	MVP, 150B	L150
Height	10.5 in.	11.5 in.
Depth	20.7 inches	20.7 inches
Width	24.6 inches	24.6 inches
Weight	60 lbs	70 lbs
Shipping	31.69 in. wide; 28.19 in. deep; 17.38 in. high; 75 lbs.	29.7 in. wide; 26.3 in. deep; 16.1 in. high; 90 lbs.
Environmental	Temperature	Humidity
Operating	0 to 40 degrees C.	10% to 90% rh noncondensing
Storage	- 40 to +70 degrees C.	5% to 95% rh noncondensing
Acoustic Noise	60 dBa maximum on <i>Printronix</i> pedestal	
Product Certification		
UL	UL Standard 478 Listing.	
FCC	FCC Rules, Part15, Docket 20780-Part A Compliance.	

Operator Controls and Indicators

Specifications	Characteristics/Function	
Switches/Indicators	(Internal and External Panels)	
Power ON/OFF	Turns printer On/Off; (includes circuit breaker for 150B)	
RDY (Ready)	Places/indicates printer on-line or off-line	
CHK (Check)	Indicates/clear fault condition	
8 LPI	Selects line spacing in lines per inch (LPI)	
TOF	Advances paper one line or to top-of-form; set form: and indicator lights if forms length set in lines. Indicator does not light if forms length is set in inches.	
Second Function	MVP, L150	150B
MODE	Selects Mode 001-005.	Selects print mode 001-006.
F/L	Sets forms length.	Sets forms length.
ADDR	Selects address code for test data or Configuration Option.	Selects memory address for DATA codes.
DATA	Selects test data or Configuration Option.	Selects test data or Configuration Option.
2nd FUNC	Activates internal switch functions.	Activates internal switch second functions.
Numeric Display	Three digit; displays codes for print mode, forms length, fault conditions, test patterns, and Configuration Options.	Three digit; displays codes for print mode, forms length, fault conditions, test patterns, and Configuration Options.
Mechanical Controls		
Tractors	Horizontal forms alignment.	
Vertical Alignment Knob	Manually advances forms.	
Forms Adjustment Thickness Lever	Adjusts platen opening for paper thickness or multiple copies.	
Top-of-Form Pointer	Marks top-of-form location.	

Interfaces

Specifications	Centronics	Dataproducts (RS-232 Serial)
Data Input Format	7 or 8 bit parallel, ASCII	See page 8-5.
Input Buffer	Full line.	See page 8-5.
Data Transfer Rate	Up to 200,000 char/sec	Up to 400,000 char/sec

Index

A

- ADDR, 3–7
- ASCII Character Set, A–1
- ASCII Control Codes by Function
 - formatting commands, A–10
 - forms control, A–8
 - graphic modes, A–7
 - paper feed, A–9
 - print quality, A–6
 - print width, A–5
 - selecting print modes, A–7
 - special printer features, A–8
- ASCII Dot Patterns, 5–3

B

- Bit Image Graphics, 5–8
 - characteristics of, 5–8
 - density, 5–11
 - other features, 5–14
 - plotting, 5–10
 - programming format, 5–12
 - sample program, 5–13
 - single density sample, 5–13
- BS/CR Protocol, A–4

C

- Cables
 - interface, 8–26
 - reconnecting, 9–8
- Centronics Interface, 8–3
 - characteristics, 8–2
 - input signals, 8–4
 - output signals, 8–4
- Character Formation, 1–8

- Check (CHK), 3–4
- Cleaning, 9–5
 - before, 9–3
 - external, 9–2
 - internal, 9–2
 - requirements, 9–2
- Clear Check Condition, B–2
- Configuration
 - change procedure (150B), 4–4
 - change procedure (MVP/L150), 4–3
 - methods of configuring, 4–2
 - verifying changes, 4–5
- Configuration Options (150B), 4–6
 - Auto Line Feed on CR (23), 4–12
 - Binary Count Slew (25), 4–14
 - Buffer Print with TOF (44), 4–29
 - Characters Per Inch in Mode 5 (48), 4–33
 - Column Print Spacing (56), 4–37
 - Control Code Assignments (31–41), 4–25
 - Delete Code 7F (29), 4–18
 - Double Wide Print Operation (20), 4–9
 - ESC DC1 Sequence (58), 4–38
 - EVFU Control (42), 4–27
 - EVFU Control with no PI (46), 4–31
 - Forms Length at Power Up (52), 4–36
 - Inhibit Lowercase/Underline (24), 4–13
 - Input Buffer Size (57), 4–38
 - Insert Auto Line Feed (22), 4–11
 - Line Spacing at Power Up (54), 4–37
 - LPI Line Spacing (51), 4–35
 - Mode 4 (45), 4–30
 - Page Perforation Skip (50), 4–34
 - Paper Out Delay (27), 4–16
 - Plotting Exit (43), 4–28
 - Print or Graphics Mode (30), 4–19
 - Printer On–line with Power On (26), 4–15
 - SOH and ETX (47), 4–32

- Underline (28), 4–17
- Version (59), 4–38
- Vertical Dot Density (21), 4–10
- Configuration Options (MVP/L150), 4–6
 - Auto Line Feed on CR (23), 4–12
 - Binary Count Slew (25), 4–14
 - Buffer Print with TOF (44), 4–29
 - Control Code Assignments (31–41), 4–20
 - Delete Code 7F (29), 4–18
 - EVFU Control (42), 4–27
 - Forms Length at Power Up (52), 4–36
 - Host Mode Control Pgm. Stnd. (20), 4–8
 - Inhibit Lowercase/Underline (24), 4–13
 - Insert Auto Line Feed (22), 4–11
 - LPI Line Spacing (51), 4–35
 - Page Perforation Skip (50), 4–34
 - Paper Out Delay (27), 4–16
 - Plotting Exit (43), 4–28
 - Print or Graphics Mode (30), 4–19
 - Printer On–line with Power On (26), 4–15
 - Underline (28), 4–17
 - Vertical Dot Density (21), 4–10
- Configuration Options 20 to 59 Table, 4–7
- Control Codes (150B), 7–3, 7–27
 - ASCII Character Control Codes Table, 7–29
 - ASCII Characters, 7–28
 - Horizontal Tab, 7–36
 - Mode Selection from Host, 7–40
 - Underline (Methods 1 & 2), 7–41
- Control Codes (MVP/L150), 7–3
 - Alternate Character Set Deselect (0FH), 7–7
 - Alternate Character Set Select (0EH), 7–7
 - Carriage Return (0DH), 7–6
 - Dot Density, 7–15
 - Editing, 7–17
 - Elongated Characters (08H), 7–13

- Even Dot Plot (04H), 7–8
- EVFU (10H–1FH), 7–26
 - Host Mode Control (01H), 7–20
 - Host Mode Control (09H), 7–20
 - Host Mode Control (0EH), 7–20
 - Host Mode Control (0FH), 7–20
 - Host Mode Control (1BH), 7–20
 - Line Feed (0AH), 7–4
 - Lines per Inch Spacing (06H), 7–12
 - Odd Dot Plot (05H), 7–8
 - Slewing a Specified Number of Lines, 7–18
 - Space (20H), 7–26
 - Top–of–Form/Perforation Skip (0CH), 7–5
 - Underline (5FH), 7–14
- Control Codes Quick Reference Table, 7–3

D

- DATA, 3–7
- Dataproducts Interface, 8–5
 - characteristics, 8–2
 - input signals, 8–6
 - output signals, 8–7

E

- EVFU
 - channel assignment, 6–3
 - command codes, 6–5
 - end load code – 6F, 6–4
 - programming example, 6–5
 - start load code – 6H, 6–2
 - troubleshooting, 6–7
 - with IGP, 6–9
- EVFU Memory, 6–2
 - clearing, 6–11
 - programming, 6–2
 - using, 6–8
- Extended Character Set, A–2

F

Fault Code Chart, B-2

Features

150B/L150B, 1-6

L150, 1-6

MVP-Series, 1-5

optional, 1-7

Forms Length, setting, 3-17

F/L (Forms Length), 3-5, 3-7

2nd FUNC, 3-6

G

Graphics, Single Density Bit Image Sample,
5-13

H

Host Mode (MVP/L150)

Control Code Sequence Format, 7-22

Control Code Sequence Placement, 7-23

I

Interface Config. Options (150B), 8-8

Busy Line (65), 8-13

Data Line 8 with Parallel Interface (60),
8-9

Data Lines and Response Line (63), 8-12

Data Strobe Line Polarity with PI (62),
8-11

Paper Instruction with Parallel Interface
(61), 8-10

Parallel Interface Selection (66), 8-14

Interface Config. Options (MVP/L150), 8-8

Busy Line (65), 8-13

Clear to Send/Carrier Detect (75), 8-20

Current Loop Out (81), 8-24

Data Line 8 with Parallel Interface (60),
8-9

Data Lines and Response Line (63), 8-12

Data Set Ready (76), 8-21

Data Strobe Line Polarity with PI (62),
8-11

Data Terminal Ready (78), 8-23

Data Word Interface (72), 8-17

Paper Instruction with Parallel Interface
(61), 8-10

Parallel Interface Selection (66), 8-14

Protocol Char. Asgn. ETX (84), 8-25

Protocol Char. Asgn. XOFF/NAK (83),
8-25

Protocol Char. Asgn. XON/ACK (82), 8-25

Request to Send (74), 8-19

Reverse Channel (77), 8-22

Serial Data Transfer (71), 8-16

Serial Interface/Protocol (70), 8-15

Transmitted Data Polarity (73), 8-18

XOFF Buffer Level (80), 8-24

XON Buffer Level (79), 8-24

L

Line Printing, 1-9

8LPI (8 Lines Per Inch), 3-4

M

Maintenance

- corrective, 9–9
- electronic, 9–9
- mechanical, 9–9
- system, 9–9

Mechanical Controls, 3–2

MODE, 3–6

Moving the Printer, 9–7

O

Odd Dot Plot Pattern Plan, 5–20

On/Off, 3–3

Operator Panel, (see also, Switches), 3–3

P

P-Series Plot Mode, 5–15

- exiting, 5–22
- plot data byte format, 5–16
- plot data line format, 5–18
- plot density, 5–15
- plotting data, 5–20
- programming example, 5–21

Paper

- guidelines, 3–11
- loading, 3–12
- removing, 3–15
- thickness, 3–11
- type, 3–11

Paper Tray

- assembling, 2–8
- attaching, 2–10

Pedestal

- assembling, 2–5

mounting, 2–9

table top mounting, 2–11

Plot, 1–11

- odd dot pattern plan, 5–20
- rate, 1–11
- truncated character line, 5–22

Power, applying, 2–12

Power Requirements, 2–3

Print, 1–10

Mode, 1–10

Printer Diagnostics, B–1

- bypass soft fault, B–1
- clear check condition, B–2
- fault code chart, B–2
- printer fault conditions, B–1

Printing, rate, 1–10

R

Raster Plot

- exiting, 5–7
- high resolution, 5–6
- print modes, 5–5
- syntax, 5–4

Raster Plotting, 5–2

ASCII Dot Patterns, 5–3

Rate

- plot, 1–11
- print, 1–10

Ready (RDY), 3–4

Relative Line Slewing, 6–9

Requirements

- power, 2–3
- site, 2–4

Ribbon

- loading, 3–8
- removing, 3–10

S

- Self-Tests, 9–10, 9–11
 - automatic sequence, 9–13
 - configuration, 9–12
 - hex dump mode, 9–17
 - paper motion, 9–16
 - print, 9–15
 - procedure, 9–10
 - repeating, 9–14
- Serial Matrix Bit Image Graphics, 5–2
- Site Requirements, 2–4
- Specifications, C–1
 - electrical, C–6
 - environmental, C–6
 - interfaces, C–8
 - operator controls and indicators, C–7
 - paper and ribbon, C–5
 - physical, C–6
 - print format, C–3
 - printer performance, C–1
 - product certification, C–6
- Switches
 - 2nd FUNC, 3–6
 - 8LPI (8 Lines Per Inch), 3–4
 - ADDR, 3–7
 - Check (CHK), 3–4
 - DATA, 3–7
 - F/L (Forms Length), 3–5, 3–7
 - MODE, 3–6
 - Ready (RDY), 3–4
 - TOF (Top-of-Form), 3–5
- Switching Interfaces, 8–26

T

- Terminating Resistors, 8–26
- Testing, preliminary, 2–12
- Top-of-Form, Setting, 3–16
- TOF (Top-of-Form), 3–5
- Truncated Character Line, 5–22

.....
PRINTRONIX
17500 CARTWRIGHT ROAD
P.O. Box 19559
IRVINE, CA. 92713-9559
PHONE: 714/863-1900
FAX: 714/660-8682

PRINTRONIX
NEDERLAND BV
P.O. BOX 163, NIEUWEG 283
NL-6600 AD WIJCHEN
THE NETHERLANDS
PHONE: (31) 2464-90170
FAX: (31) 2464-19768

PRINTRONIX
A.G.
512 CHAI CHEE LANE, HEX 02-15
BEDOK INDUSTRIAL ESTATE
SINGAPORE 1646
PHONE: (65) 449-7555
FAX: (65) 449-7553

Free Manuals Download Website

<http://myh66.com>

<http://usermanuals.us>

<http://www.somanuals.com>

<http://www.4manuals.cc>

<http://www.manual-lib.com>

<http://www.404manual.com>

<http://www.luxmanual.com>

<http://aubethermostatmanual.com>

Golf course search by state

<http://golfingnear.com>

Email search by domain

<http://emailbydomain.com>

Auto manuals search

<http://auto.somanuals.com>

TV manuals search

<http://tv.somanuals.com>