

PRINTRONIX®

P5000LJ Series Printers

User's Manual

PRINTRONIX®

P5000LJ Series Printers

User's Manual

READ THIS SOFTWARE LICENSE AGREEMENT BEFORE USING THIS PRINTER

Software License Agreement

CAREFULLY READ THE FOLLOWING TERMS AND CONDITIONS BEFORE USING THIS PRINTER. USING THIS PRINTER INDICATES YOUR ACCEPTANCE OF THESE TERMS AND CONDITIONS. IF YOU DO NOT AGREE TO THESE TERMS AND CONDITIONS, PROMPTLY RETURN THE PRINTER AND ALL ACCOMPANYING HARDWARE AND WRITTEN MATERIALS TO THE PLACE YOU OBTAINED THEM, AND YOUR MONEY WILL BE REFUNDED.

Definitions.

“Software” shall mean the digitally encoded, machine-readable data and program. The term “Software Product” includes the Software resident in the printer and its documentation. The Software Product is licensed (not sold) to you, and Printronix either owns or licenses from other vendors who own, all copyright, trade secret, patent and other proprietary rights in the Software Product.

License.

1. Authorized Use. You agree to accept a non-exclusive license to use the Software resident in the printer solely for your own customary business or personal purposes.
2. Restrictions.
 - a. To protect the proprietary rights of Printronix, you agree to maintain the Software Product and other proprietary information concerning the typefaces in strict confidence.
 - b. You agree not to duplicate or copy the Software Product.
 - c. You shall not sublicense, sell, lease, or otherwise transfer all or any portion of the Software Product separate from the printer, without the prior written consent of Printronix.
 - d. You may not modify or prepare derivative works of the Software Product.
 - e. You may not transmit the Software Product over a network, by telephone, or electronically using any means; or reverse engineer, decompile or disassemble the Software.
 - f. You agree to keep confidential and use your best efforts to prevent and protect the contents of the Software Product from unauthorized disclosure or use.
3. Transfer. You may transfer the Software Product with the printer, but only if the recipient agrees to accept the terms and conditions of this Agreement. Your license is automatically terminated if you transfer the Software Product and printer.

Limited Software Product Warranty

Printronix warrants that for ninety (90) days after delivery, the Software will perform in accordance with specifications published by Printronix. Printronix does not warrant that the Software is free from all bugs, errors and omissions.

Remedy

Your exclusive remedy and the sole liability of Printronix in connection with the Software is replacement of defective software with a copy of the same version and revision level.

Disclaimer of Warranties and Limitation of Remedies

1. THE PARTIES AGREE THAT ALL OTHER WARRANTIES, EXPRESS OR IMPLIED, INCLUDING WARRANTIES OF FITNESS FOR A PARTICULAR PURPOSE AND MERCHANTABILITY ARE EXCLUDED. Printronix does not warrant that the functions contained in the Software will meet your requirements or that the operation of the Software will be uninterrupted or error free.
Printronix reserves the right to make changes and/or improvements in the Software without notice at any time.
2. IN NO EVENT WILL PRINTRONIX BE LIABLE FOR LOST PROFITS, LOST DATA, BUSINESS INTERRUPTIONS, OR ANY OTHER DIRECT, INDIRECT, INCIDENTAL OR CONSEQUENTIAL DAMAGES ARISING OUT OF THE USE OF OR INABILITY TO USE THIS PRODUCT, EVEN IF PRINTRONIX HAS BEEN ADVISED OF THE POSSIBILITY OF SUCH DAMAGES, OR ANY DAMAGES CAUSED BY THE ABUSE OR MANIPULATION OF THE SOFTWARE. SOME STATES DO NOT ALLOW THE EXCLUSION OR LIMITATION OF LIABILITY FOR CONSEQUENTIAL OR INCIDENTAL DAMAGES, SO THE ABOVE LIMITATION MAY NOT APPLY TO YOU.
3. Printronix will not be liable for any loss or damage caused by delay in furnishing a Software Product or any other performance under this Agreement.
4. Our entire liability and your exclusive remedies for our liability of any kind (including liability for negligence except liability for personal injury caused solely by our negligence) for the Software Product covered by this Agreement and all other performance or nonperformance by us under or related to this Agreement are limited to the remedies specified by this Agreement.
5. California law governs this Agreement.

Termination of License Agreement

This License shall continue until terminated. This license may be terminated by agreement between you and Printronix or by Printronix. If you fail to comply with the terms of this License and such failure is not corrected within thirty (30) days after notice. When this License is terminated, you shall return to the place you obtained them, the printer and all copies of the Software and documentation.

U.S. Government Restricted Rights

Use, duplication or disclosure by the Government is subject to restrictions as set forth in the Rights in Technical Data and Computer Software clause at FAR 242.227-7013, subdivision (b) (3) (ii) or subparagraph (c) (1) (ii), as appropriate. Further use, duplication or disclosure is subject to restrictions applicable to restricted rights software as set forth in FAR 52.227-19 (c) (2).

Acknowledgment of Terms and Conditions

YOU ACKNOWLEDGE THAT YOU HAVE READ THIS AGREEMENT, UNDERSTAND IT, AND AGREE TO BE BOUND BY ITS TERMS AND CONDITIONS. NEITHER PARTY SHALL BE BOUND BY ANY STATEMENT OR REPRESENTATION NOT CONTAINED IN THIS AGREEMENT. NO CHANGE IN THIS AGREEMENT IS EFFECTIVE UNLESS WRITTEN AND SIGNED BY PROPERLY AUTHORIZED REPRESENTATIVES OF EACH PARTY. BY USING THIS PRINTER, YOU AGREE TO ACCEPT THE TERMS AND CONDITIONS OF THIS AGREEMENT.

Printronix makes no representations or warranties of any kind regarding this material, including, but not limited to, implied warranties of merchantability and fitness for a particular purpose. Printronix shall not be held responsible for errors contained herein or any omissions from this material or for any damages, whether direct, indirect, incidental or consequential, in connection with the furnishing, distribution, performance or use of this material. The information in this manual is subject to change without notice.

This document contains proprietary information protected by copyright. No part of this document may be reproduced, copied, translated or incorporated in any other material in any form or by any means, whether manual, graphic, electronic, mechanical or otherwise, without the prior written consent of Printronix.

COPYRIGHT © 2000, 2003 PRINTRONIX, INC.

All rights reserved.

Trademark Acknowledgments

Hewlett-Packard, HP, HP-UX, Bi-Tronics, HP in a circle, Hewlett Packard, PCL and HP rounded rectangle are registered trademarks of Hewlett-Packard Company.

AIX, AS/400, IBM, NetView, Proprinter and OS/2 are registered trademarks, and AFP, Intelligent Printer Data Stream, IPDS, Print Services Facility, and PSF are trademarks of International Business Machines Corporation.

IBM and Proprinter are registered trademarks, and PC-DOS is a trademark of International Business Machines Corporation.

Portions of this manual used by permission of Wyndham Technologies, Inc. Copyright © 1991-1999 Wyndham Technologies Inc.

ANSI is a registered trademark of American National Standards Institute, Inc.

Centronics is a registered trademark of Genicom Corporation.

DEC is a registered trademark of Digital Equipment Corporation.

DG/UX is a registered trademark of Data General Corporation.

EIA is a registered trademark of the Electronic Industries Association.

ENERGY STAR is a registered trademark of the United States Environmental Protection Agency. As an ENERGY STAR[®] Partner, Hewlett-Packard has determined that this product meets the ENERGY STAR[®] guidelines for energy efficiency.

Epson is a registered trademark of Seiko Epson Corporation.

Ethernet is a trademark of Xerox Corporation.

Frontier Technologies and SuperTCP are trademarks or registered trademarks of Frontier Technologies Corporation.

FTP Software and OnNet are trademarks or registered trademarks of FTP Software, Inc.

IGP, PGL, LinePrinter Plus, Network Interface Card (NIC) and Printronix are registered trademarks, and RibbonMinder is a trademark of Printronix, Inc.

IRIX is a registered trademark of Silicon Graphics, Inc.

LINUX is a registered trademark of Linus Torvalds.

Magnum and QMS are registered trademarks, and Code V is a trademark of Quality Micro Systems, Inc.

Microsoft, MS, MS-DOS, Windows, and Windows NT are registered trademarks of Microsoft Corporation.

PKZIP and PKUNZIP are registered trademarks of PKWARE, Inc.

NetManage and Chameleon are trademarks or registered trademarks of NetManage, Inc.

Netscape and Netscape Navigator are registered trademarks, and the Netscape Communications logo is a trademark of Netscape Communications Corporation.

Novell and NetWare are registered trademarks of Novell, Inc.

PostScript is a registered trademark of Adobe Systems Inc.

Solaris is a registered trademark of Sun Microsystems, Inc.

Ultrix is a registered trademark of Digital Equipment Corporation.

Unix is a registered trademark of X/Open Company Limited.

This product uses Intellifont Scalable typefaces and Intellifont technology. Intellifont is a registered trademark of Agfa Division, Miles Incorporated (Agfa).

CG, Garth Graphic, Intellifont, and Type Director are registered trademarks, and Shannon and CG Triumvirate are trademarks of Agfa Division, Miles Incorporated (Agfa). CG Bodoni, CG Century Schoolbook, CG Goudy Old Style, CG Melliza, Microstyle, CG Omega, and CG Palacio are products of Agfa Corporation. CG Times, based on Times New Roman under license from The Monotype Corporation Plc is a product of Agfa.

Univers is a registered trademark of Linotype AG and/or its subsidiaries.

Letraset is a registered trademark, and Aachen, Revue and University Roman are trademarks of Esselte Pendaflex Corporation.

Futura is a registered trademark of Fundición Tipográfica Neufville, S.A.

ITC Avant Garde Gothic, ITC Benguiat, ITC Bookman, ITC Century, ITC Cheltenham, ITC Clearface, ITC Galliard, ITC Korinna, ITC Lubalin Graph, ITC Souvenir, ITC Tiepolo, ITC Zapf Chancery, and ITC Zapf Dingbats are registered trademarks of International Typeface Corporation.

Albertus, Gill Sans, and Times New Roman are registered trademarks, and Monotype Baskerville is a trademark of The Monotype Corporation Plc, registered in the U.S. Pat. and TM office and elsewhere.

Hiroshige and Marigold are trademarks of AlphaOmega Typography, Inc.



Table Of Contents

1	Introduction	17
	About This Manual	17
	Warnings, Cautions, And Notes	17
	Printing Conventions Used In This Manual	17
	Related Documents.....	18
	Printer Overview.....	19
	The Printronix P5000LJ Series Printer Family	19
	Taking Care Of Your Printer.....	21
	Standard Features	21
	Graphics Options	23
	Protocols And Emulations	23
	Line Matrix Printing	24
	Printing Speed.....	25
	Network Interface Card (NIC).....	26
	What Special Features Are Available?.....	26
	NIC	27
2	Downloading Function Code In	
	P5000LJ Series Printers	29
	Introduction.....	29
	Downloading In A Nutshell	29
	Preparation For Downloading.....	30
	Copying Function Code To Your Computer	31
	Loading Function Code To Flash Memory In The Printer	32
	Installing Printer Emulations.....	32
	Downloading Software Through the Serial	
	or Parallel Port	33
	Downloading Software Through the	
	Network Interface Card (NIC).....	37
	Downloading Optional Font Files to Flash Memory.....	39

3	Configuring The Printer	45
	Overview	45
	Configuring The Printer	45
	Operating Modes.....	48
	The Configurations.....	48
	Locking And Unlocking The ENTER Key.....	48
	Changing And Saving Parameter Settings.....	49
	Factory Default Configuration Values	50
	Changing Parameters	54
	Example	54
	Saving Your New Configuration	56
	Printing The Current Configuration	58
	Loading Configuration Values	60
	The Power-Up Configuration.....	62
	Deleting Configurations.....	64
	Protecting Your Configurations	66
	Configuring NIC.....	67
	Connecting To The Network	67
	Configuration Setup	67
	Configuration Using The Printer Control Panel.....	68
	Configuration Alternatives.....	69
4	The Configuration Menus	73
	Overview	73
	Configuration Main Menu	74
	Config. Control Menu	77
	Active Emulation Menu.....	79
	Emulation Menu	80
	PCL-II Emulation	81
	LP Plus Emulation	86
	P-Series Emulation	90
	Proprinter XL Emulation	93
	Epson FX Emulation	95
	Serial Matrix Emulation	97
	P-Series XQ Emulation	100
	IGP/PGL Emulation.....	102
	IGP/VGL (Code V) Emulation	107
	Maint/Misc Menu	114

Host Interface Menu	115
Bi-Tronics Submenu	116
Centronics (Parallel) Submenu	117
Serial Submenu	119
Ethernet Submenu	122
Auto Switching Submenu	123
Ethernet Params Menu	125
Printer Control Menu	127
Diagnostics Menu	129
RibbonMinder	132
RibbonMinder Menu	133
5 Approaches To Network Printing	137
Overview	137
Peer To Peer Networks	137
Print Job Servers	138
Logical Printer Architecture	138
6 Embedded NIC Web Page	141
Overview	141
Configuration	142
Configuration Network	143
TCP/IP Network	143
Windows Network (NetBIOS TCP/IP)	144
Novell Network	144
Configuration Print Path	145
Destination Settings	145
Current Model Settings	146
Current Log Path Settings	147
Configuration - Print Model	147
Configuration - Log Path	148
Configuration - I/O Port	149
Parallel Port (PRN)	149
Configuration – SNMP	150
Configuration - Administration	154
System Information	154
Passwords	154
Configuration - System	155
Status	155
Status - I/O Port	155
Status - Network	155

7	TCP/IP Configuration	157
	TCP/IP NIC Configuration	157
	Before You Begin	157
	Creating Aliases	158
	Methods For Setting TCP/IP Values	159
	Assign TCP/IP Values.....	160
	Using BOOTP	163
8	HP e3000/NIC Configuration.....	165
	Overview	165
	HP e3000 / MPE-XL / MPE / iX: Host Configuration	165
	NIC Configuration Verification	168
	Methods Of Adjusting Paper Position.....	170
	Method 1	170
	Method 2	171
	Using Page Level Recovery On P5000LJ Printers.....	171
	HP e3000 / MPE-XL / MPE / iX: DTC Configuration	173
	MPE-XL / MPE / iX Typical Configuration	173
9	Windows Configuration	175
	Overview	175
	Windows Environment Description.....	175
	Windows NIC Configuration	176
	Mandatory	176
	Optional.....	176
	Communicating Across Routers.....	177
	Changing Workgroup Names.....	177
	Changing Destination Names	178
	Windows Host Configuration	179
	Windows NT 3.51 Host Setup.....	179
	Windows NT 4.0 Host Setup	180
	Windows 95/98/ME Host Setup	186
	Windows 3.1 Host Setup.....	187
	Windows Troubleshooting Tips	187
	NIC Cannot Be Found On The Network.....	188
	HTML Configuration Forms Will Not Display.....	188
	Errors Occur When Defining An LPR Printer	188
	Cannot Browse The NIC On The Network.....	189
	Printer Errors When Printing Or No Output.....	189
	TCP/IP Access Problem.....	189

Web Browser/HTTP Problem	191
Windows NT 4.0 or 2000 Host Setup Problems	191
Installing Microsoft TCP/IP Printing	191
10 Unix Configuration	193
Overview	193
Unix Environment Description	194
Unix NIC Configuration	195
Mandatory	195
Optional	195
Communicating Across Routers	195
Unix Host Configuration	196
Printing Setup On HP-UX	196
Printing Setup On Sys V	198
LPR/LPD Printing Setup On BSD Systems (Sun 4.x, DEC, Ultrix,, Free BSD, etc.)	200
FTP Printing	201
Remote Shell Printing	201
Unix Troubleshooting Tips	202
Nothing Prints	202
Stair-stepped Output	203
No Form Feed Or Extra Page Comes Out	203
11 Novell Configuration	205
Overview	205
Novell Environment Description	206
Novell NIC Configuration	206
Using HTML Forms	207
Novell Host Configuration	208
NetWare Version 3.x PSERVER Setup	208
NetWare Version 3.x RPRINTER Setup	210
NetWare Version 4.x and 5.x PSERVER Setup	211
NetWare Version 4.x and 5.x RPRINTER Setup	213
Novell Troubleshooting Tips	215
NetWare 3.x - No PSERVER Connection	215
NetWare 4.x and 5.x - No PSERVER Connection	216

12 Novell Configuration For 10/100Base-T	
Interfaces.....	217
Overview	217
Novell NIC Configuration (10/100Base-T)	217
Preferred File Server (NDS & Bindery)	218
Setting Password Security (NDS & Bindery).....	221
Adjusting Polling Time (NDS & Bindery)	222
Changing The Print Server Name (NDS & Bindery)	223
Changing The Frame Type (NDS & Bindery).....	225
Changing The Print Server Mode (NDS & Bindery)	226
Setting The NIC Context (NDS)	227
Setting The Print Server Preferred NDS Tree (NDS).....	228
Novell Host Configuration (10/100Base-T).....	229
NDS PSERVER Setup (Netware 4.x and 5.x).....	229
Bindery PSERVER Setup (Netware 3.x, 4.x, and 5.x)	231
Referencing A Bindery Queue In NDS (Netware 3.x, 4.x, and 5.x)	231
RPRINTER/NPRINTER Setup (Netware 3.x, 4.x, and 5.x)	232
NPDS Configuration (Netware 4.11 and Above)	234
Troubleshooting (10/100Base-T).....	236
PSERVER Setup.....	236
RPRINTER/NPRINTER Setup	239
Printing Related.....	240
13 Commands	243
Command Shell Overview	243
Access Methods	243
Main Command Shell Prefixes	243
Getting Command Help.....	243
Complete Command List.....	244
Store Commands	244
Set Commands	247
List Commands	254
Debug Commands	255
Miscellaneous Commands	256

14 Extra Features	259
NIC Security	259
Users And Passwords	259
TCP Access Lists	261
Printer Monitoring And Logging	262
Printer And Print Job Monitoring	262
Printer Logging Through Logpaths	263
NIC Naming Schemes	264
15 Interfaces	265
Overview	265
Centronics Parallel Interface	266
Centronics Interface Signals	267
Centronics Parallel Interface Configuration	267
Bi-Tronics Parallel Interface	268
Operating Modes	268
The Negotiation Phase	269
Signals	269
RS-232 And RS-422 Serial Interfaces	271
RS-232 And RS-422 Serial Interface Signals	272
RS-232 And RS-422 Serial Interface Protocol	273
RS-232 And RS-422 Serial Interface Error Handling	273
RS-232 And RS-422 Serial Interface Configuration	274
16 Routine Service And Diagnostics	275
Routine Service	275
Exterior Cleaning	275
Interior Cleaning	275
Diagnosing Problems	278
Printer Self-Tests	278
Printing A Hex Dump	280
Fault Messages	282
A Printer Specifications And Regulatory Information	291
Ribbon Specifications	291
Genuine Printronix P5000LJ Supplies	293
Printer Dimensions	294
Environmental Characteristics	294
Electrical Characteristics	295
Material Safety Data Sheets	296
Communication Notices	297

B	Paper Specifications And Forms Design.....	301
	Introduction.....	301
	General Paper Specifications.....	301
	Paper Guidelines.....	303
	Terms And Definitions.....	303
	Environmental Considerations	305
	Form Types	305
	Form Weight.....	305
	Form Thickness.....	305
	Form Evenness	305
	Tractor Pin Engagement	305
	Methods Of Forms Attachment	306
	Chaff Content	307
	Form Design Checklist	308
	Summary	310
	Storage And Handling	310
C	Standard ASCII Character Set	313
D	Monitoring Printers	315
	Implementing Remote Management Software (RMS).....	315
	Agent/Manager Model.....	315
	MIB.....	315
	SNMP.....	316
	Monitoring Tools.....	317
	Monitoring With AIX NetView/6000	317
	Monitoring With Web JetAdmin.....	317
	OS/2 TCP/IP	317
	Setting The SNMP Community Name.....	317

1

Introduction

About This Manual

This manual explains how to configure and perform routine service on the Printronix® P5000LJ Series printers for maximum efficiency.

Warnings, Cautions, And Notes

Read and comply with all information highlighted under special headings:

Warning



Warning messages call attention to situations that could hurt you or damage the equipment.

Caution



Conditions that could damage the printer or related equipment.

Note



A note gives you helpful hints about printer operation and maintenance.

Printing Conventions Used In This Manual

- UPPERCASE print indicates control panel keys.
Example: Press the CLEAR key, then press the ON LINE key.
- Quotation marks (“ ”) indicate messages you see on the Liquid Crystal Display (LCD).
Example: Press the ON LINE key. “OFFLINE” appears on the LCD.
- The + (plus) symbol represents key combinations.
Example: “Press ▲ + ▼” means to press the ▲ (UP) key and the ▼ (DOWN) key at the same time.

- Command syntax and examples are formatted as follows:
 - The Courier font in **boldface** indicates commands that you type:
Example: `$ ping ftp.HP.com`
 - Regular Courier font indicates displayed results:
Example: `ftp.HP.com is alive`
 - Variable values are shown in *italics* in command syntax, output, and in text.
Example: `ping ipname`
Example: `ipname is alive`

Related Documents

Following is a list of related documentation shipped with every Printronix P5000LJ printer.

- *P5000LJ Series Printers Installation Instructions, Cabinet and Pedestal Models* — Explains in a step-by-step process how to set up the printer for operation.
- *P5000LJ Series Printers Quick Reference Guide* — Describes the keys on the control panel and provides quick reference information on daily printer operations such as loading paper and replacing ribbons. Italian, French, German, and Spanish are included.

Note



This manual and the reference manuals listed below are located on the software starter CD shipped with your P5000LJ printer.

- *P5000LJ Series Printers PCL-II/LinePrinter Plus Technical Reference Manual* — Describes the host control codes and character sets for the LinePrinter Plus® and PCL®-II emulations.
- *P5000LJ Series Printers IGP/VGL Technical Reference Manual* — Explains how to write graphics programs using the optional QMS® Code V™ Printronix® emulation. This graphics programming language allows the user to create and store forms; generate logos, bar codes, and expanded characters; create other graphics; and merge graphics with alphanumeric data as a document is printed.
- *P5000LJ Series Printers IGP/PGL Technical Reference Manual* — Explains how to write graphics programs using the optional PGL® Printronix IGP® emulation. This graphics programming language allows the user to create and store forms; generate logos, bar codes, and expanded characters; create graphic images; and merge graphics with alphanumeric data as a document is printed.

Printer Overview

The Printronix P5000LJ Series Printer Family

The P5000LJ series of line matrix printers consists of 500, 1000, and 1500 lines per minute (lpm) models packaged in various configurations. All of the models offer software versatility and the latest refinements in line matrix printing technology. The model numbers indicate printing speed and physical configuration:

Table 1. The P5000LJ Series Printer Family

Model Number US	Model Number Europe	Nameplate	Print Speed	Pedestal	Cabinet	Serial/ Parallel Interface	Serial/ Ethernet Interface	Power Stacker
C3201D	C3201E	500P	500 lpm	✓		✓		
C3201ND	C3201NE	500P	500 lpm	✓			✓	
C3202D	C3202E	500Q	500 lpm		✓	✓		
C3202ND	C3202NE	500Q	500 lpm		✓		✓	
C3203D	C3203E	1000P	1000 lpm	✓		✓		
C3203ND	C3203NE	1000P	1000 lpm				✓	
C3204D	C3204E	1000Q	1000 lpm		✓	✓		
C3204ND	C3204NE	1000Q	1000 lpm		✓		✓	
C3205D	C3205E	1500Q	1500 lpm		✓	✓		
C3205ND	C3205NE	1500Q	1500 lpm		✓		✓	
C3206D	C3206E	1500P	1500 lpm	✓		✓		
C3206ND	C3206NE	1500P	1500 lpm	✓			✓	
C5640D	C5640E	1500QS	1500 lpm		✓			✓
C5640ND	C5640NE	1500QS	1500 lpm		✓		✓	✓

Most line matrix printers have specialized architectures which enable the printer to emulate, or behave like, another printer. These specialized architectures are restricted. The P5000LJ printer, however, introduces an open architecture concept that is not available on any other line matrix printer.

The P5000LJ printer offers the standard emulation of Hewlett-Packard's Printer Control Language, PCL Level II, to allow easy online programming capabilities and compatibility with Hewlett-Packard systems. The Printronix P5000LJ Series printers are fully compatible with HP LineJet and LP Series printers.

Additionally, the P5000LJ printer offers the following three emulations as part of its LinePrinter Plus grouping: Proprinter® III XL, Epson® FX-1050, and Serial Matrix P-Series. No matter what emulation is configured, your printer is very easy to use. The message display and indicator on the control panel communicate with you directly and clearly. You can select every function on your printer at the control panel, or you can send commands from the host computer.

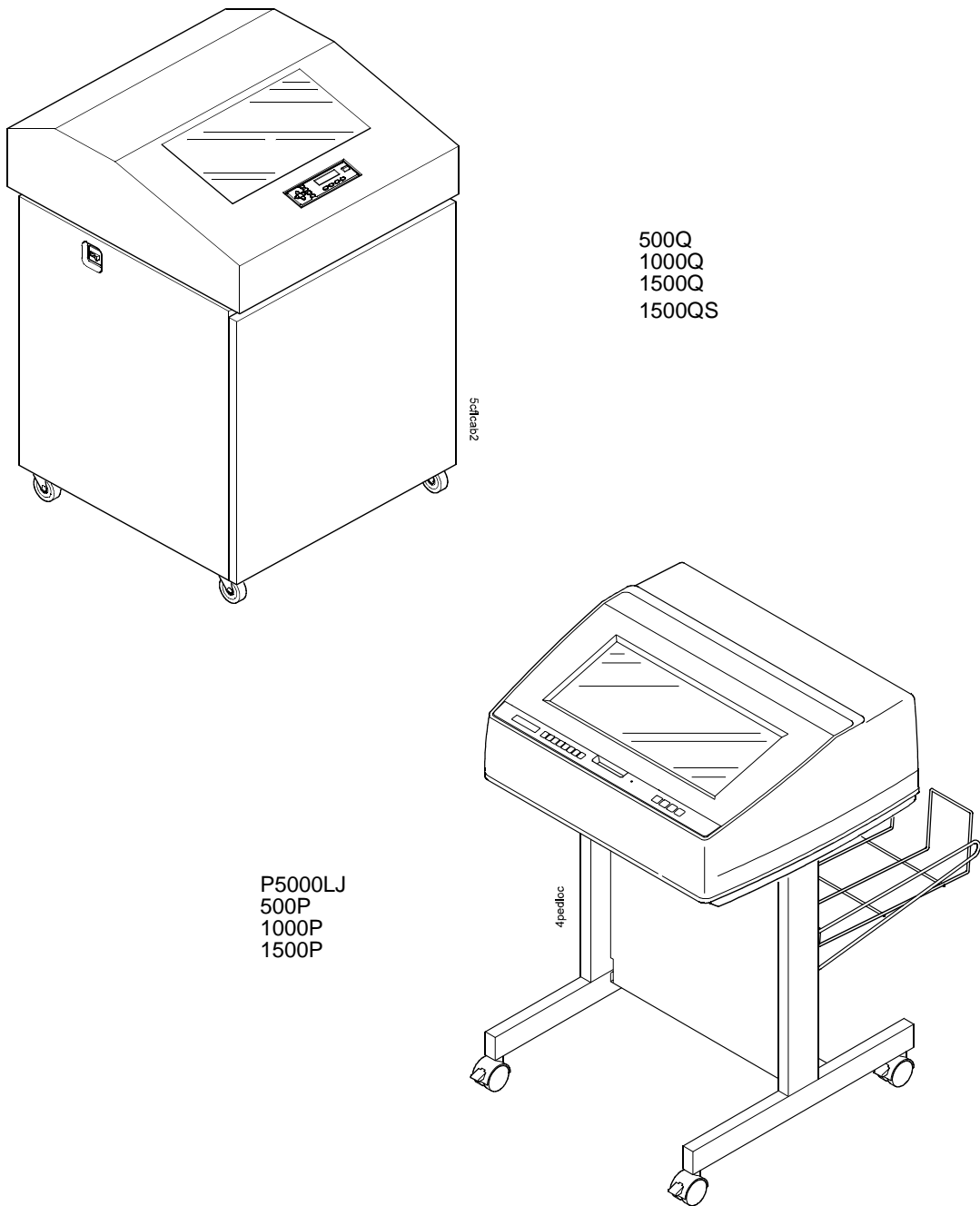

Figure 1. The P5000LJ Printers

Taking Care Of Your Printer

Your printer will produce high quality print jobs if it is well taken care of. Periodic cleaning, handling the printer properly, and using the correct printer supplies, such as paper and ribbons, will ensure optimum performance. Chapter 16 explains how to clean the printer, and printer supplies are listed in Appendix A.

Whenever it is necessary to service the printer, remember these important maintenance concepts:

- Use only the ribbons specified in Appendix A. Use of incorrect ribbons can cause ink migration problems, degraded print quality, and expensive damage to the printer.
- Incorrect closure of the forms thickness lever can cause smearing, degraded print quality, paper jams, and damage to the platen and shuttle assembly. Never close the forms thickness lever too tightly.
- Excessive printing outside of the boundaries of the paper will degrade print quality and cause hammer bank damage. Never print outside of the paper width.

Standard Features

All of the printers offer a wide range of horizontal and vertical dot densities, operate quietly, and can load an emulation very easily. Other features are specified in the following sections.

Host Computer Interfaces

The following host computer interface choices are available:

- Bi-Tronics®
- RS-232 serial interface
- RS-422 serial interface
- Centronics®
- Ethernet™ (optional on 500P and 500Q only)

Printer Emulations

The following printer emulations (or protocols) are selectable at the control panel:

- HP® PCL-II (the default)
- LP Plus, which consists of:
 - Printronix P-Series
 - Epson FX-1050
 - IBM® Proprinter III XL
- QMS (optional)
- PGL (optional)

Each emulation provides a different set of configuration menus, control codes, and character sets.

Output Control

Depending on the active emulation, the printers have the following output control features:

- Four modes for printing text:
 1. Correspondence (High Density)
 2. Data Processing (DP) (Standard Density)
 3. Sparse (high speed) (Sparse Density)
 4. OCR A and OCR B
- Selectable forms length and width
- Character attribute specification:
 1. Selectable pitch: normal, expanded, and compressed
 2. Emphasized (**shadow**) printing
 3. Automatic underlining and overscoring
 4. Superscript and subscript printing
 5. Double high and wide printing
- Resident multinational character sets and bar codes

Graphics and Vertical Formatting

Several graphics and vertical formatting features are available:

- Built-in graphics generators:
 1. IBM Proprinter III XL bit-image graphics
 2. Epson FX-1050 dot graphics mode
 3. P-Series Plot
 4. PCL raster graphics
- Programmable electronic vertical formatting provides rapid vertical paper movement to specified lines for printing repetitive and continuous forms. You can choose from the following methods:
 1. Vertical tabbing in Proprinter III XL and Epson FX emulation modes
 2. Electronic Vertical Format Unit (EVFU) in P-Series emulation mode
 3. PCL vertical forms control (VFC)

Built-in Diagnostic Tools

The following diagnostic tools are provided with the printer:

- Comprehensive diagnostic self-tests permanently stored in the printer
- Configuration printout
- Data stream hex code printout
- Symbol set printout

Graphics Options

The PGL and VGL emulations allow you to create and store forms; generate logos, bar codes, and expanded characters; and create other graphics. Alphanumerics and bar code data are added as the form is printed.

Protocols And Emulations

A *protocol* is a set of rules governing the exchange of information between the printer and its host computer. These rules consist of codes which manipulate and print data and allow for machine-to-machine communication. A printer and its host computer must use the same protocol.

Most impact printers use single ASCII character codes to print text, numbers, and punctuation marks. Some characters, both singularly and in groups of two or more, are defined as control codes. Control codes instruct the printer to perform specific functions, such as underlining text, printing subscripts, setting page margins, etc. The main difference between most printer protocols is in the characters used to create control codes and the ways in which these characters are formatted.

When the printer executes the character and control codes of a particular printer protocol, it is "emulating" that printer. For example, if the printer uses the Proprinter III XL protocol, it is emulating an IBM Proprinter III XL printer; if the printer is using the Epson FX-1050 printer protocol, it is in Epson FX-1050 emulation mode. As used in this manual, "protocol" and "emulation" mean the same thing.

Line Matrix Printing

Your printer is an impact printer; it creates characters by printing ink dots on paper. The dots are printed on an invisible matrix mapped in printer memory (see Figure 2). Dot impressions are made by an array of steel hammers mounted on a rapidly oscillating shuttle. The hammers strike the paper through a moving ink ribbon.

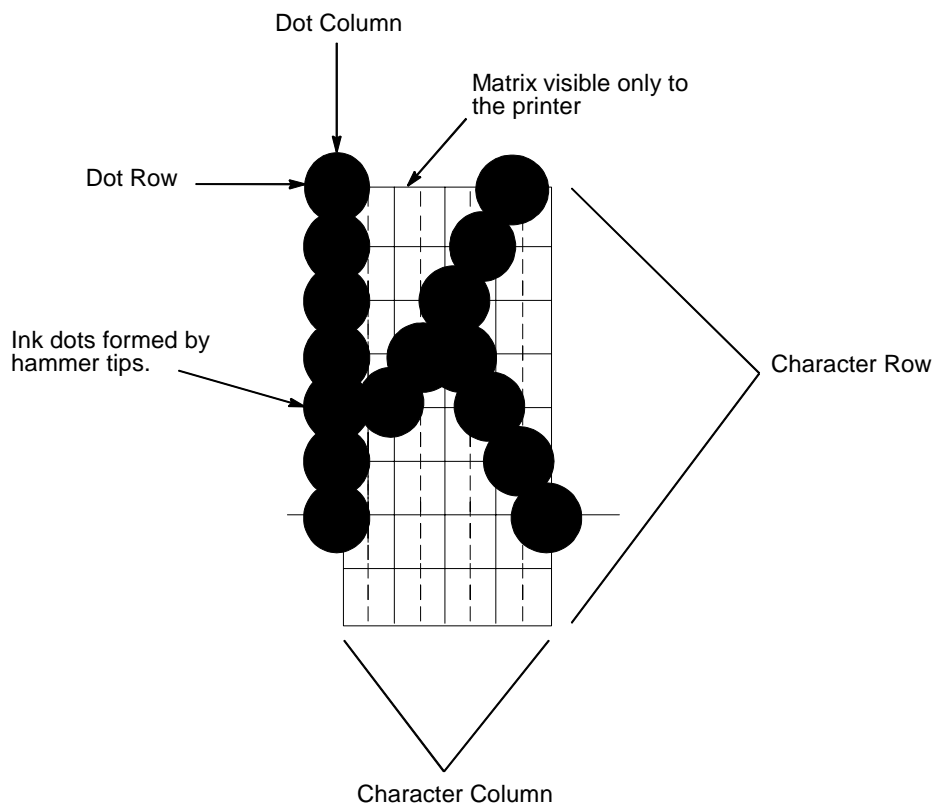

Figure 2. Dot Matrix Character Formation

Serial matrix printers use a moving printhead with pins to form single characters sequentially along the printed line. Unlike serial matrix printers, the P5000LJ printer is a line matrix printer. Line matrix printers divide every printable line into horizontal dot rows, then print a dot row of the entire line at every lateral sweep of the shuttle.

During each sweep, hammers are activated to print dots at the required positions in the dot row. When the shuttle reaches the end of a sweep, it reverses direction, the paper advances one dot row, and the hammers print the next row of dots as the shuttle sweeps in the opposite direction, as shown in Figure 3.

After a line of characters is printed, the paper advances to the first dot row of the next print line. This creates a number of blank rows between lines of characters, depending on the print mode and line spacing you selected.

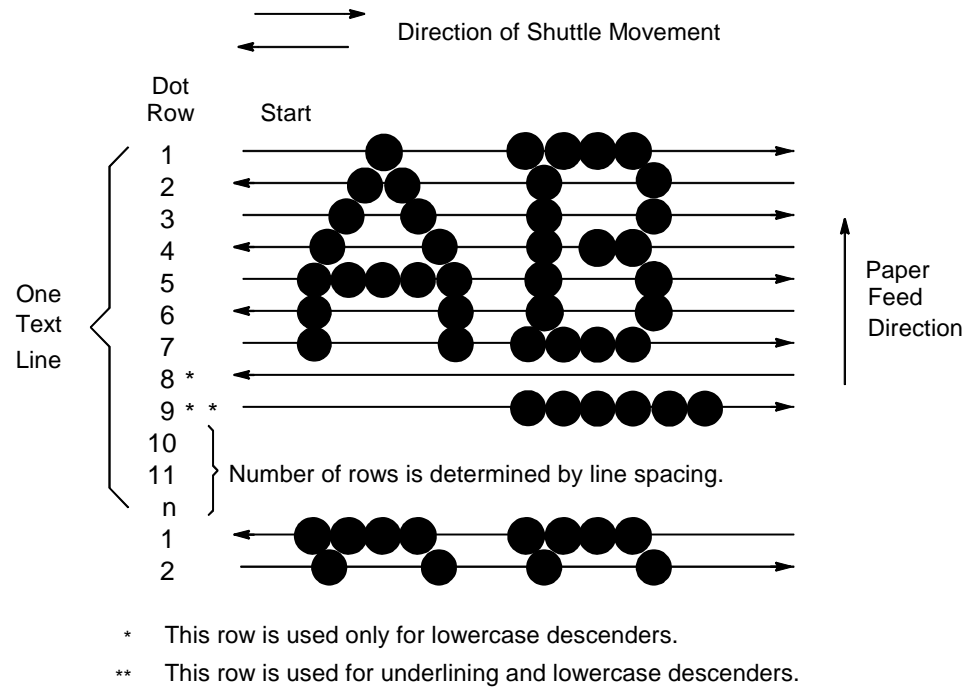

Figure 3. Dot Matrix Line Printing

Printing Speed

The speed at which text prints is measured in lines per minute (lpm). This speed is directly proportional to the number of dot rows required to produce a character line, regardless of the number of characters in the line. More dot rows are required to print lowercase characters with descenders; consequently, those character lines print at a fractionally lower rate.

The printer also prints dot-addressable graphic images. The speed at which graphics are plotted is measured in inches per minute (ipm). Unidirectional plotting produces slightly better print quality and takes about twice as long as bidirectional plotting. You can select either plotting mode from the control panel.

Printing and plotting rates also vary according to the print mode you select. Print mode refers to the way you instruct the printer to create characters. If, for example, you select standard quality (data processing) mode, the printer uses more dot rows to form characters than if you choose Sparse (high speed) mode. Character formation and print speed are faster in Sparse mode, because the printer prints fewer dot rows to form characters. Vertical dot density is a factor in printing speed.

Nominal printing rates are charted in Appendix A.

Network Interface Card (NIC)

Network Interface Card (NIC) allows you to attach printers on a local area network (LAN) rather than attaching them directly to a host system. Following simple configuration steps, these peripherals can be simultaneously shared with users on the network whether you are using TCP/IP, NetBIOS over TCP/IP, or IPX (Novell®).

NIC contains a network interface card to attach itself and the printer to the network. This Ethernet™ 10/100Base-T interface connector is what allows the printer to communicate with the network, and the interface itself has a number of options, status indicators, and switches which are described in “NIC” on page 27.

What Special Features Are Available?

NIC offers an extensive list of features including:

- built-in HTML forms for easy cross-platform configuration
- availability of printer manager software
- a detailed and easy-to-use command shell built in to the firmware
- multi-level configuration security through passwords, permission levels, and access lists
- Wide Area Network (WAN) communication access
- numerous printer logging methods (e.g., automatic email) to record printer errors and usage
- remote management through HTML forms, Telnet sessions, **rsh/rcmd/remsh** commands, SNMP, and pre-defined log methods
- extensive built-in troubleshooting tools
- built-in **telnet** and **ping** clients
- configurable memory usage by disabling protocols and destination services
- multiple destinations/queues for versatile printer manipulation and distinct print setups
- header and trailer strings to instruct printers on font, pitch, printing, etc.
- flexible naming conventions
- automatic network connection and frame type sensing
- simultaneous printing across all I/O ports and all supported protocols
- multiple network protocol support

NIC

The NIC at the rear of the printer has two indicator lights and two dipswitches, as shown in Figure 4.

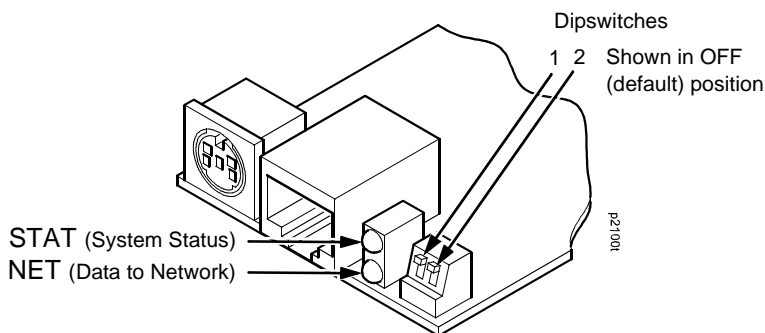

Figure 4. Status Indicator Lights and Dipswitches

Run and Auto Reset Modes

Run Mode is the normal operating state of NIC. Auto Reset mode is entered when the watchdog timer is triggered and the Print Server resets itself. In either mode, the STAT LED flashes at a varying rate, depending on whether the unit IP address is configured. The Run Mode and Auto Reset Mode indicator descriptions are given in Table 2.

Table 2. Indicator Modes

STAT	Indication	Description
OFF	flashes on once per second	Normal Mode, IP address configured
OFF	flashes on twice per second	IP address not configured
ON	flashes off once per second	Download (MOS)
ON	flashes off twice per second	Error

Network Indicator

The NET LED displays the status of the network link. When the NET LED is on, link integrity is confirmed. The NET LED flashes off for 1/3 second when a data packet is being transferred. When the NET LED is off, the network connection has been severed.

Dipswitches

On the back of the interface, you will find a small window where you can access two dipswitches labeled 1 and 2 (see Figure 4). The functions of the dipswitches are explained in Table 3.

Table 3. Dipswitch Functions

Dipswitch		Comments
1	2	
OFF	OFF	Normal operation. With both dipswitches in the OFF position, the NIC boots up using the settings in flash memory rather than the default settings.
ON	OFF	Factory default settings. With the dipswitches in this configuration, the NIC boots up and erases all settings stored in flash memory except the Ethernet address and key value.
OFF	ON	Default IP. With the dipswitches in this configuration, the NIC boots up with factory default settings. However, the stored settings in flash memory are intact. Setting dipswitch 2 to ON does not clear any settings stored in flash memory; instead, it boots the unit with the IP settings in flash memory temporarily ignored.
ON	ON	Reserved. This dipswitch setting is not for customer use.

2

Downloading Function Code In P5000LJ Series Printers

Introduction

Downloading the function code is equivalent to updating firmware in the printer. This chapter explains how to load function code into P5000LJ printers.

You must download function code when:

- you require upgraded firmware for maintenance or other reasons;
- the CMX controller board is replaced;
- the flash memory SIMM is replaced;
- the NIC is installed or replaced;
- you need different emulation software or buy the VGL or PGL graphics option after the printer is installed.

Downloading In A Nutshell

Updating the function code in a P5000LJ printer consists of three tasks:

1. Obtaining the appropriate download file and loading it into the PC or laptop you will use to download the code into the printer.
2. Obtaining the appropriate interface cable if necessary.
3. Printing all saved configurations in the printer, making the function code upgrade, and restoring your saved printer configurations.

Preparation For Downloading

There are several function code files available for the P5000LJ printers. The file you use depends on the printer emulation in use.

Note

Always upgrade the function code to the latest version available that meets the minimum flash memory and DRAM SIMM sizes listed in Table 4.

To verify what function code is already installed, observe the control panel display when the printer is online. If a configuration printout is available, the function code file version is printed at the top of the configuration printout on the line that begins "Program File Version." For example, if the line is "Program File Version (2.07P Part No. 356351), the number "356351" is the function code download file active at the time the configuration printout was generated.

You can download function code from a networked PC or laptop computer which contains the function code. If the printer has the NIC installed, the function code must be updated via the network to successfully update the NIC firmware. Loading function code via the network is done using the Printronix Remote Management (RMS) software available on the PrintNet Enterprise CD or using the file transfer protocol (ftp) procedure.

Table 4. P5000LJ Series Printers Function Code Chart

	Description	Control Panel Displays: (Emulation in Use)	Download File (as shipped)	Download Method	Minimum Flash/DRAM Required
If Serial or Parallel Connected					
	Printers using PCL-II emulation	ONLINE-PARL / PCL II* (or) ONLINE-PARL / LP PLUS*	xxxxxx.exe (Note 2)	Parallel or Serial Port	4 MB Flash 4 MB DRAM
	Printers using VGL emulation	ONLINE-PARL / PCL II / VGL*	xxxxxx.exe (Note 2)	Parallel or Serial Port	4 MB Flash 4 MB DRAM
	Printers using PGL emulation	ONLINE-PARL/LP PLUS/PGL*	xxxxxx.exe (Note 2)	Parallel or Serial Port	4 MB Flash 4 MB DRAM
If Network Connected					
	Printers using PCL-II emulation	ONLINE-ETHERNET / PCL II (or) ONLINE-ETHERNET / LP+	xxxxxx.exe (Note 2)	Via Network (Note 1)	4 MB Flash 4 MB DRAM
	Printers using VGL emulation	ONLINE-ETHERNET / LP+ (or) ONLINE-E-NET / CODE V / PCL	xxxxxx.exe (Note 2)	Via Network (Note 1)	4 MB Flash 4 MB DRAM
	Printers using PGL emulation	ONLINE-ETHERNET/PGL/LP+ (or) ONLINE-ETHERNET/PCL-II	xxxxxx.exe (Note 2)	Via Network (Note 1)	4 MB Flash 4 MB DRAM
NOTES					
*	ONLINE - SERL / PCL II or ONLINE - SERL / LP PLUS if serial port is the selected host interface				
1	<p>If the internal network card is not installed or was removed, download via the parallel or serial port. If the printer Function Code is downloaded with the NIC removed, or a NIC card is added to the printer after downloading, the Ethernet port will not function with RMS. In this case, do the following:</p> <ol style="list-style-type: none"> 1. Press the up/down/right/left arrow keys simultaneously. Printer displays "FACTORY / Printer Management." 2. Press the down arrow key. Printer displays "Diagnostic Port." 3. Press the down arrow key. Printer displays "Debug Serial." 4. Press the right arrow key. Printer displays "Debug Ethernet." 5. Press ENTER. Printer displays "Debug Ethernet*." Press ONLINE to exit. 				
2	Check with Technical Support, (Customer Service Center) to confirm the latest available Function Code download file.				

Copying Function Code To Your Computer

In order to download function code to a printer if using a serial or parallel port, the function code file must reside in a PC or laptop computer running any of the following operating systems: MS-DOS[®], PC-DOS[™], or DOS session on Windows 95/98, Windows NT or Windows 2000.

Note that the downloaded file, xxxxxx.exe, is a compressed executable file. **Leave the file as it is. Do not try to execute the file.**

Loading Function Code To Flash Memory In The Printer

This section contains two loading techniques:

- How to load function code through the parallel or serial port of the printer.
- How to load function code through the Ethernet port using the file transfer protocol (ftp).

Note



If Ethernet is installed, you must install the code through the Ethernet port using ftp.

Installing Printer Emulations

Printer emulation software is stored in flash memory. Flash memory is contained in single in-line memory modules (SIMMs) located on the controller board. Printer emulation and operating system software are loaded into flash memory at the factory, but you will install software in some situations:

- A printer software upgrade is installed
- The printer controller board has been replaced
- The flash memory SIMM has been replaced

Emulation and operating system software are stored on a CD. You will copy the appropriate file to your computer's hard disk, then download that file to the printer. You can load software through the serial, parallel, or Ethernet NIC port of the printer:

Note



Each printer type, line matrix, laser, and thermal has its own CD with the specific file types for that printer. Be sure to use the appropriate CD for your printer type when downloading software.

Note



When downloading emulation and operating system software to the printer, all other optional font files, customer-supplied logos, setup files, and TIFF files will be erased. You will then need to reload those files. Before starting a download procedure, be sure that you have all the necessary files on hand.

- **Serial or Parallel Port:** If you are going to load memory through the serial or parallel port of the printer, see “Downloading Software Through the Serial or Parallel Port” on page 33. The load commands are different, depending on the printer port you use. These differences are explained in the note following step 22., page 36.
- **NIC:** If the printer has the NIC installed, see “Downloading Software Through the Network Interface Card (NIC)” on page 37.
- **Font Files:** If you need to load optional font files, see “Downloading Optional Font Files to Flash Memory” on page 39.

Downloading Software Through the Serial or Parallel Port

1. Make a printout of all saved configurations. (Installing new software erases all saved configurations. You will use the printouts to restore the printer configurations.)
2. Set the printer power switch to O (Off).
3. If the printer is already connected to the serial or parallel port of an IBM-compatible computer running the PC-DOS™ or MS-DOS operating system, go to step 9. If not, go to step 4.
4. Unplug the AC power cord from the printer.
5. Disconnect all data input cables from the printer interfaces.
6. Connect a parallel data cable to the LPT1 port or a serial data cable to the COM1 port of an IBM-compatible computer running the PC-DOS or MS-DOS operating system.

Note



You can connect the cable to the LPT2 port if the LPT1 port is already in use. The load commands are different if you use this port, as described in the note after step 22.

7. Connect the data cable to the appropriate I/O port of the printer.
8. Plug the AC power cord into the printer.
9. On the printer control panel, press and hold down the **ONLINE + PAPER ADVANCE** keys. Without releasing the keys, power the printer on. Continue holding down the keys.
10. When you see “TESTING HARDWARE PLEASE WAIT” on the LCD, release the keys.
11. Wait until you see “WAITING FOR PROGRAM DOWNLOAD” on the LCD before proceeding. This can take up to 30 seconds to appear, depending on the emulations and interfaces installed in the printer.
12. Press the ⇒ (NEXT) key. “SELECT DOWNLOAD PORT=CENTRONICS” appears on the LCD.

Note

The default port is CENTRONICS; this is the standard load through the parallel port. If you want to use the default, continue at step 14.

13. Press ⇒ (NEXT) again to cycle through the download ports available in the printer:
 - RS232-9600 (RS-232 serial, 9600 baud)
 - RS232-19.2K (RS-232 serial, 19200 baud)
 - RS232-38.4K (RS-232 serial, 38400 baud)
 - RS232-115K (RS-232 serial, 115000 baud)
 - RS422-9600 (RS-422 serial, 9600 baud)
 - RS422-19.2 (RS-422 serial, 19200 baud)
 - RS422-38.4K (RS-422 serial, 38400 baud)
 - RS422-115K (RS-422 serial, 115000 baud)
 - DEBUG
14. When the printer download port you want to use is displayed on the LCD, press the **ENTER** key. "WAITING DOWNLOAD / PORT = <your selection>" appears on the display.
15. Using Windows Explorer, create a directory named **download** at the root level of your C: hard drive.
16. Insert the printer emulation software CD into your computer.

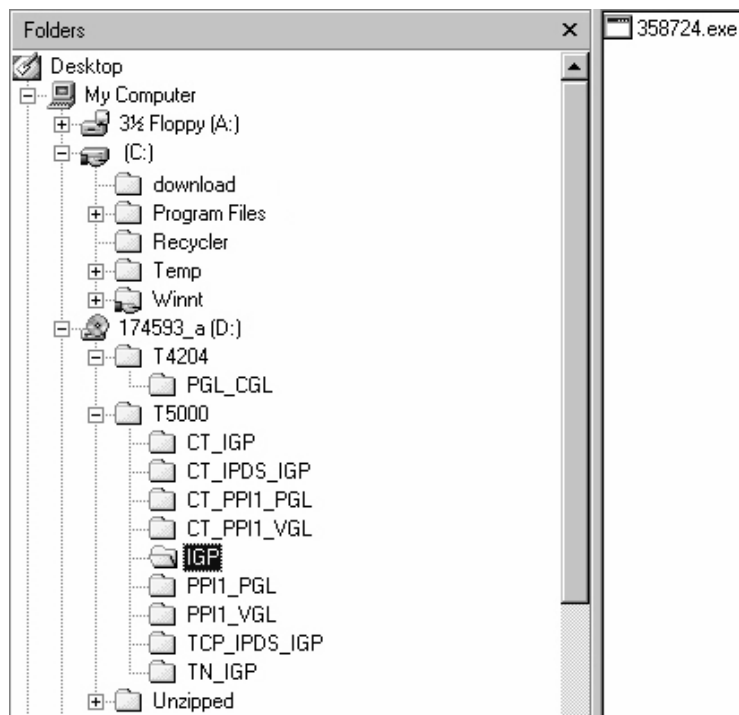

Figure 5. Navigating to the Appropriate Emulation File on the CD

17. Using Windows Explorer, navigate to the appropriate file on the CD based on the printer model number and desired emulation, e.g., T5000 ▶ IGP. (See Figure 5.)
18. Make note of the file name, which is a six digit number plus **.exe**, e.g., 123456.exe.

This is the file you will download into the printer.

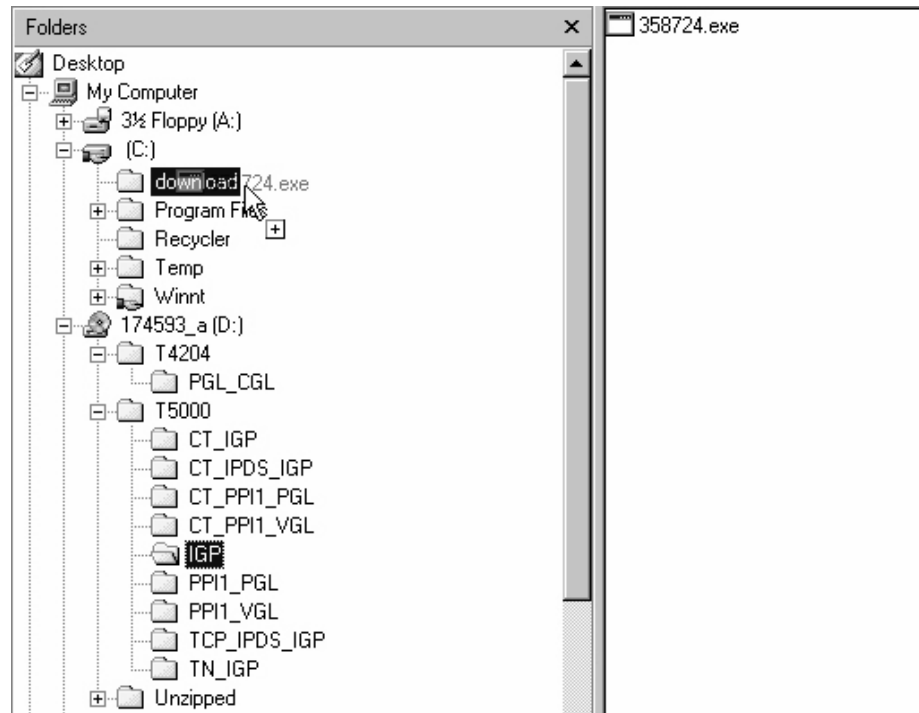

Figure 6. Copying the Emulation File to the Download Directory

19. Copy the file to the download directory.

Note



You may need to hold **Ctrl** to make sure a + appears to the right of the pointer. (See Figure 6.)

20. Start a command prompt session. (The Start Menu icon is usually labeled MS-DOS Prompt or Command Prompt.)
21. At the command prompt type:
`c: <Enter>`
`cd \download <Enter>`

22. At the command prompt on the computer type:
`filename.exe -pb<Enter>`
where *filename.exe* is the file name you noted in step 18. This command decompresses the file on the hard drive and copies it as a binary file into the flash memory on the printer controller board.

**Note**

If you are loading the file using the LPT2 port on the computer, enter the following command:

```
filename.exe -pb2 <Enter>
```

The 9600 baud rate is the only selection older versions of MS-DOS can use. The baud rate information entered in the following commands must match the selection you made in step 13.

If you are loading the file through the printer serial port, enter the following commands:

```
mode COM1:9600,N,8,1,P<Enter>
```

```
filename.exe -pbc1<Enter>
```

Caution

Do not interrupt the downloading process once it has started. Interrupting a download will damage the flash memory on the controller board and the NIC.

While the file is copied into memory, the printer LCD informs you of the load process and status.

23. When the new program has successfully loaded into memory and the printer has reset itself, set the printer power switch to O (Off).
24. Unplug the AC power cord from the printer.
25. Remove the CD from the host computer and store it with the printer.
26. Power off the computer.
27. If you had to install a data cable to the computer and printer in step 6., disconnect it from the computer and printer.
28. If required, reconnect the data input cable(s) to the printer.

Using the configuration printout(s) you made in step 1., reconfigure the printer and reload any optional font files.

Downloading Software Through the Network Interface Card (NIC)

1. Make a printout of all saved configurations. (Installing new software erases all saved configurations. You will use the printouts to restore the printer configurations.)
2. Set the printer power switch to O (Off).
3. On the printer control panel, press and hold down the **ONLINE + PAPER ADVANCE** keys. Without releasing the keys, power the printer on. Continue holding the keys down.
4. When you see “TESTING HARDWARE PLEASE WAIT” on the LCD, release the keys.
5. Wait until you see “WAITING FOR PROGRAM DOWNLOAD” on the LCD before proceeding. This can take up to 30 seconds to appear, depending on the emulations and interfaces installed in the printer.
6. Using Windows Explorer, create a directory named **download** at the root level of your C: hard drive.
7. Insert the printer emulation software CD into your computer.

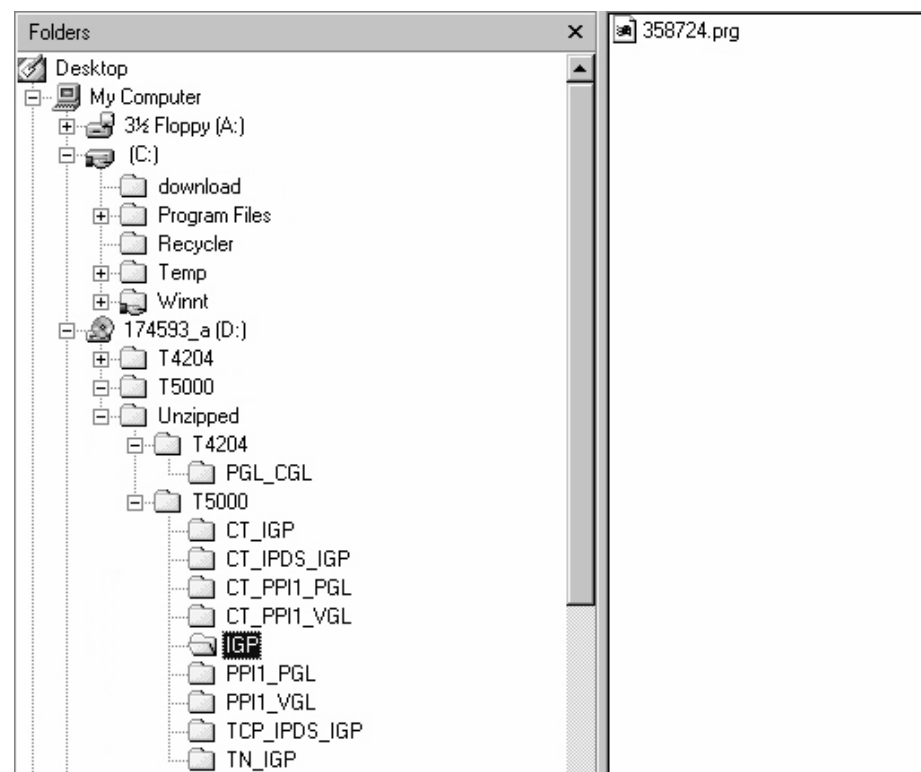

Figure 7. Navigating to the Appropriate Emulation File on the CD

8. Using Windows Explorer, navigate to the appropriate file on the CD (using the Unzipped directory) based on the printer model number and desired emulation, e.g., Unzipped ▶ T5000 ▶ IGP. (See Figure 7.)

Note

You must use the Unzipped directory, since this contains the uncompressed files necessary for NIC download.

9. Make note of the file name, which is a six digit number plus **.prg**, e.g., 123456.prg.
This is the file you will download into the NIC.
10. Copy the file to the download directory.
11. Start a command prompt session. (The Start Menu icon is usually labeled MS-DOS Prompt or Command Prompt.)
12. At the command prompt type:

```
c:><Enter>  
cd \download<Enter>
```
13. Start the FTP protocol by typing:

```
ftp xxx.xxx.xxx.xxx<Enter>
```

(where xxx.xxx.xxx.xxx represents the IP Address of the printer.)
14. Log in to the printer by typing:

```
root<Enter>
```

You are given a password prompt.

Note

The default is no password. If the FTP program requires a password, contact your system administrator.

15. At the password prompt, press <Enter>.
16. Once logged in, type the following sequence at the command prompt to download the *filename.prg* file to the printer:

```
cd dest<Enter>  
cd dlprn<Enter>  
bin<Enter>  
put filename.prg<Enter>
```

(where *filename.prg* is the file name you noted in step 9.)

Caution

Do not interrupt the downloading process once it has started. Interrupting a download will damage the flash memory on the controller board and the NIC.

17. As the file downloads, the FTP program shows the progress as a percentage. Once the download is complete, exit out of the FTP program by typing:

```
quit<Enter>
```

18. When the new program has successfully loaded into flash memory and the printer has reset itself, set the printer power switch to O (off).
19. Unplug the AC power cord from the printer.
20. Remove the CD from the host computer and store it with the printer.
21. Using the configuration printout(s), reconfigure the printer and reload any optional font files.

Downloading Optional Font Files to Flash Memory

Optional font files are stored on a 3.5 inch floppy diskette that contains file names comprised of a part number with a **.dwn** extension. You will insert the diskette in your IBM-compatible computer and use either the parallel or serial port to download the desired font file(s) to the printer's flash memory.

1. Set the printer power switch to O (off).
2. Connect a parallel data cable to the LPT1 port or a serial cable to the COM1 port of an IBM-compatible computer running the PC-DOS or MS-DOS operating system.

Note



You can connect the cable to the LPT2 port on the computer if the LPT1 port is already in use. The load commands are different if you use this port, as described in the notes after step 15.

3. Verify that the data cable is connected to the appropriate I/O port on the printer and to the host computer.
4. Power on the computer and allow it to boot up.
5. On the printer control panel, press and hold down the **ONLINE + PAPER ADVANCE** keys while powering the printer on. Continue holding the keys down.
6. When you see "WAITING FOR PROGRAM DOWNLOAD" on the LCD, release the keys.

Note



The printer default port is CENTRONICS; if you want to use this port, continue to step 15.

7. Press the ⇒ (NEXT) key; "SELECT DOWNLOAD PORT = CENTRONICS" appears on the LCD.

8. Press the ⇒ (NEXT) key again to cycle through the download ports available in the printer:
RS232-9600 (RS-232 serial, 9600 baud)
RS232-9600 (RS-232 serial, 19200 baud)
RS232-9600 (RS-232 serial, 38400 baud)
RS232-9600 (RS-232 serial, 115000 baud)
RS422-9600 (RS422 serial, 9600 baud)
RS422-9600 (RS422 serial, 19200 baud)
RS422-9600 (RS422 serial, 38400 baud)
RS422-9600 (RS422 serial, 115000 baud)
DEBUG
9. When the printer download port you want to use is displayed on the LCD, press the **ENTER** key. "WAITING DOWNLOAD / PORT" = <your selection> appears on the display.
10. Insert the optional font diskette into diskette drive A (or B) of the computer.
11. Start a command prompt session. (The Start Menu icon is usually labeled MS-DOS Prompt or Command Prompt.)
12. Make the diskette drive the active drive by typing:
A:<Enter> (if the diskette is in drive B, type **B:**<Enter>)
13. List the contents of the diskette at the command prompt by typing the following:
dir<Enter>
You will see a directory listing containing files with a **.dwn** extension, e.g., 94021.dwn, 94022.dwn, 94023.dwn.
14. Make note of the file name with the **.dwn** extension of each file you want to download to the printer.

Note

The numeric portion of the file name will match the numbers of the font typefaces listed in Appendix E of the PGL and VGL Programmer's Reference Manuals and provide you with a description and print sample of the typeface.

15. At the command prompt type:
copy /b filename.dwn LPT1<Enter>
(where *filename.dwn* is file name you noted in step 14.)

Note



If you are loading the file using the LPT2 port on the computer, type the following command:

```
copy /b filename.dwn LPT2<Enter>  
(where filename.dwn is a file you noted in step 14.)
```

If you are loading the file using the serial port on the computer, type the following commands:

```
mode COM1:9600,N,8,1,P<Enter>  
copy /b filename.dwn COM1<Enter>  
(where filename.dwn is a file you noted in step 14.)
```

The 9600 baud rate is the only selection older versions of MS-DOS can use. The baud rate information entered in the above commands must match the selection you made in step 8.

You can download the optional font files one at a time by entering one file name per the **copy** command or you can copy multiple files in one **copy** command.

To download one file at a time, enter the following at the command prompt:

```
copy /b filename.dwn LPT1<Enter>
```

To download multiple files, enter the following at the command prompt, for example:

```
copy /b filename1.dwn+filename2.dwn+...LPT1<Enter>
```

16. While the font file is copied into flash memory, the printer LCD informs you of the load process and status. When the new file is successfully loaded into memory, the printer will reset itself and go online.

17. To verify that the optional fonts have been downloaded:

a. Perform a configuration printout.

— OR —

b. Select **MAINT/MISC ▶ File Systems ▶ View Files List**. The new file names will appear with the same part number file name you downloaded, but with an **.sf** extension.

Note



The optional font typefaces cannot be selected via the printer control panel. They can only be selected via a software command from the host.

Note



Press the **ONLINE** key to place the printer online and return the printer to normal operation.

Table 5. Flash Memory Message Guide

Message	Explanation	Required Action
CLEARING PROGRAM FROM FLASH	The program successfully loaded into printer RAM and the checksum matched. The old program is now being deleted from flash memory.	None
DIAGNOSTIC PASSED	The printer passed its memory and hardware initialization tests.	None
ERROR: DC PROGRAM NOT VALID	Printer cannot find the data controller program or the validation checksum is corrupt.	<ol style="list-style-type: none"> 1. Download the program again. 2. If the message occurs again, replace the flash memory.
ERROR: DRAM AT ADDRESS XXXXXXXX	The printer found a defective memory location.	Replace the DRAM.
ERROR: EC PROGRAM NOT VALID	Printer cannot find the engine controller program or the validation checksum is corrupt.	<ol style="list-style-type: none"> 1. Download the program again. 2. If the message occurs again, replace the flash memory.
ERROR: EC STOPPED AT STATE XXXX	Hardware fault in the engine controller.	Replace the CMX controller board.
ERROR: FLASH DID NOT PROGRAM	The printer could not find any flash memory.	<ol style="list-style-type: none"> 1. Download the program again. 2. If the message occurs again, replace the flash memory.
ERROR: FLASH NOT DETECTED	The printer could not find any flash memory.	Install flash memory before attempting to download this program.
ERROR: NO DRAM DETECTED	The printer could not find any DRAM.	Check DRAM on CMX. If present, reseal DRAM, If missing, install DRAM.
ERROR: NVRAM FAILURE	The non-volatile memory has failed.	Replace the CMX controller board. (Do NOT attempt to replace NVRAM.)
ERROR: PROGRAM NEEDS MORE DRAM	The printer requires more DRAM memory in order to run the downloaded program.	Add DRAM or use a smaller emulation program.

Table 5. Flash Memory Message Guide (continued)

Message	Explanation	Required Action
ERROR: PROGRAM NEEDS MORE FLASH	The printer requires more flash memory in order to run the downloaded program.	Add flash memory or use a smaller emulation program.
ERROR: PROGRAM NOT COMPATIBLE	The printer is not compatible with the downloaded program.	Use the correct emulation software option(s) for this model.
ERROR: PROGRAM NOT VALID	The printer does not see a program in flash memory.	There is no program in printer memory. Download the program again.
ERROR: SECURITY PAL NOT DETECTED	The security PAL is not present or has failed.	Check the security PAL at location U54 on the CMX controller. If the PAL is absent, install correct PAL. If security PAL is present, replace the CMX controller board.
ERROR: SHORT AT ADDRESS XXXX	Hardware failure in DRAM or CMX controller circuitry.	Replace DRAM. If message occurs with new DRAM, replace CMX controller board.
ERROR: WRITING TO FLASH	Hardware or software fault in flash memory.	<ol style="list-style-type: none"> 1. Download the program again. 2. If the message occurs again, replace the flash memory.
ERROR: WRONG CHECKSUM	The printer received the complete program but the checksum did not match. The data were corrupted during download.	Download the program again.
ERROR OCCURRED FLUSHING QUEUES *	An interim message that displays while the printer discards host data it cannot use because a fault condition exists. While this message displays, the asterisk (*) rotates.	Wait. When the asterisk (*) stops rotating, a different fault message will appear: troubleshoot the final message.
LOADING PROGRAM FROM PORT XX%	The new program is loading into printer RAM. XX indicates how much of the program has loaded.	None

Table 5. Flash Memory Message Guide (continued)

Message	Explanation	Required Action
LOADING PROGRAM INTO FLASH	The printer has deleted the previous program from flash memory and is loading the new program into flash memory.	None
PLEASE WAIT...RESET IN PROGRESS	The printer finished loading the program into flash memory and is automatically resetting itself.	None
RESTORING BOOT CODE	Normal download initialization message.	None
SECURITY CODE VIOLATION	The software running or being downloaded does not match the security PAL code.	Install the correct PAL or program. (PAL and program must match.)
SENDING PROGRAM TO EC PROCESSOR	The printer is loading the engine controller program into the engine controller.	None
TABLE MISMATCH DOWNLOAD AGAIN	EC software update in process.	Download the program again.

3

Configuring The Printer

Overview

Note

Configuration directly affects printer operation. Do not change the configuration of your printer until you are thoroughly familiar with the procedures in this chapter.

This chapter is a tutorial that explains how to configure the P5000LJ printer and the NIC.

Configuring The Printer

In order to print data, the printer must respond correctly to signals and commands received from the host computer. Configuration is the process of matching the printer's operating characteristics to those of the host computer and to specific tasks, such as printing labels, or printing on different sizes of paper.

The characteristics that define the printer's response to signals and commands received from the host computer are called configuration parameters.

A configuration consists of all the parameters under the Active Emulation, Emulation, Maint/Misc., Host Interface, Printer Control, and Diagnostics menus. Chapter 4 describes the configuration submenus and their parameters in more detail.

You configure the printer by pressing keys on the control panel (Figure 8) or by sending control codes from the host computer. This chapter explains how to change parameters and save, print, and load configurations with the control panel. All of the keys are described in detail in the *P5000LJ Series Printers Quick Reference Guide* which is shipped with each printer.

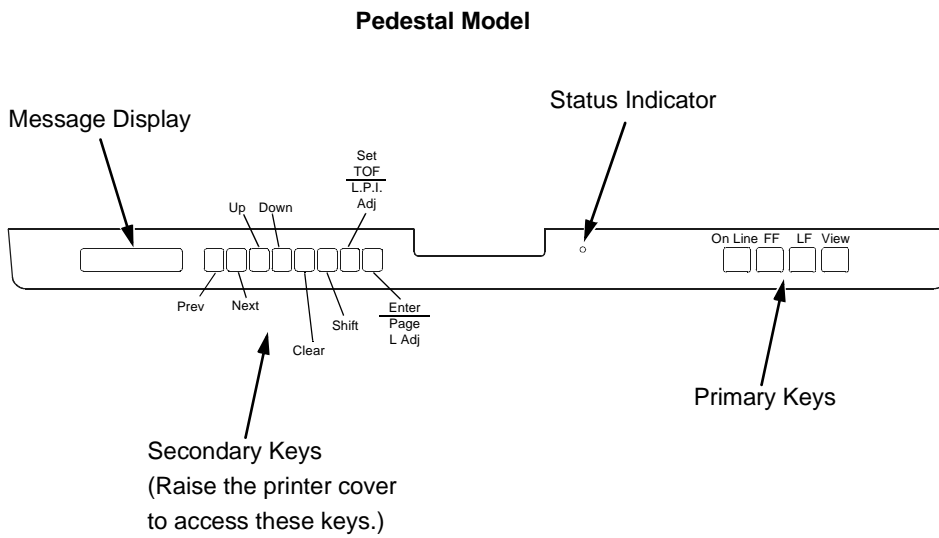
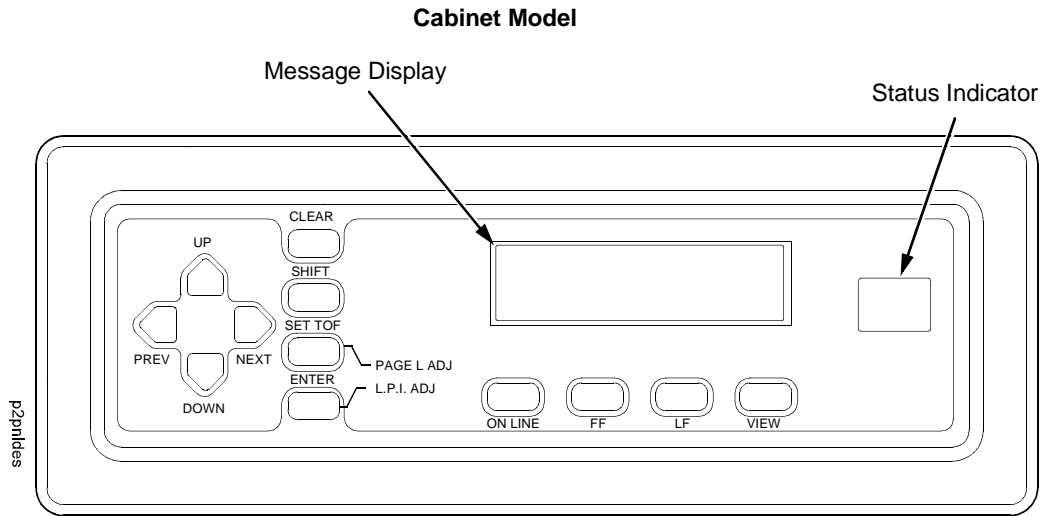
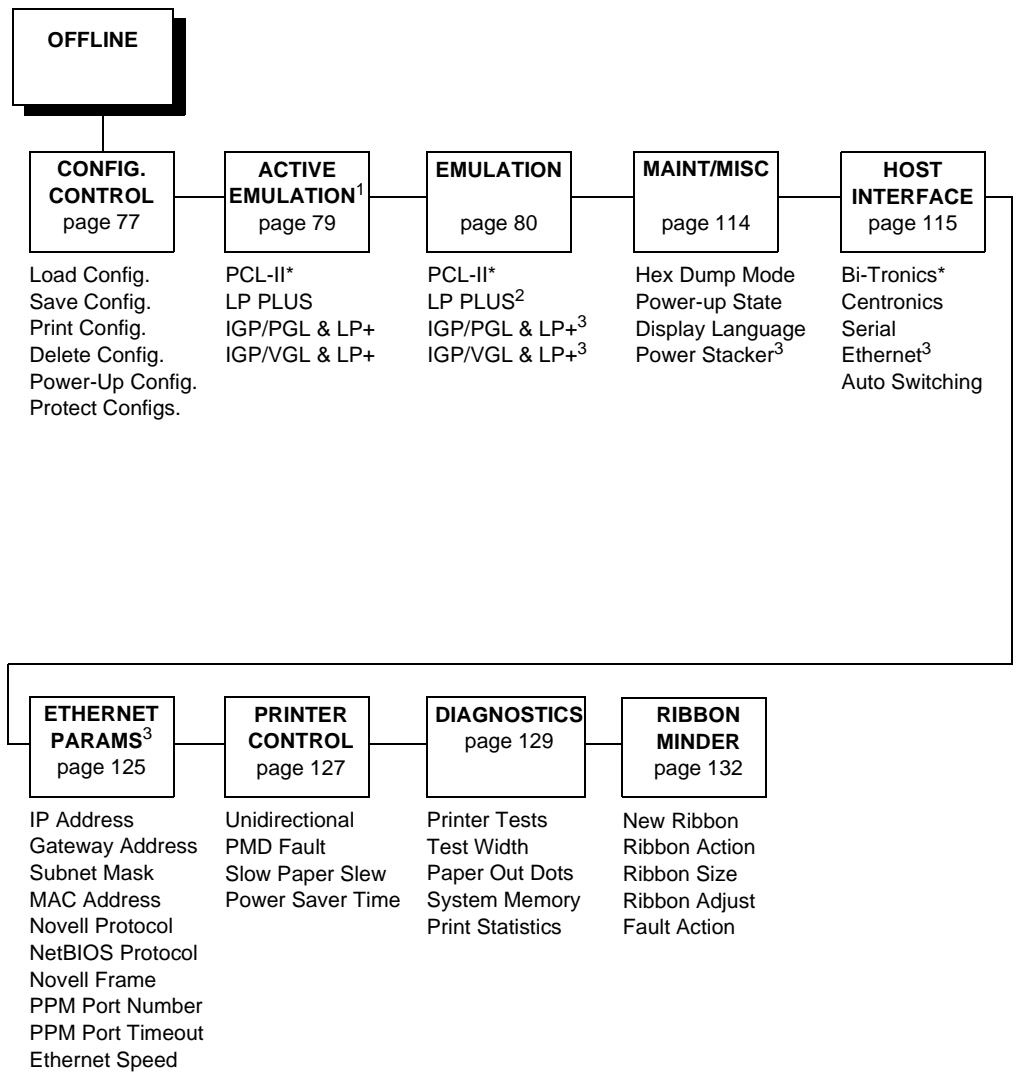

Figure 8. The Control Panels



¹ Choices available are limited to the emulations installed on the printer.

² Appears only if LP Plus is the active emulation.

³ Appears only if installed.

To view options, press: ▼ Down
▲ Up
► Next
◀ Prev

To select an option, press ENTER.

To return to main menu, press CLEAR.

To exit menu, press ON LINE.

* = Default Setting

Figure 9. Configuration Menu Overview

Operating Modes

The printer has two operating modes: online and offline. When the printer is online, it is controlled by the host computer and prints data sent by the host computer. When the printer is offline, communication with the host is interrupted so you can load paper, change ribbons, or test and configure the printer.

Activate configuration settings with the ENTER key, which enters your new setting into printer memory. An asterisk (*) after a displayed setting shows it is entered into memory.

If pressing ENTER to select a parameter produces no result, press DOWN to move to the next lower level. For example, if you press ENTER while CONFIG. CONTROL/ Print Config. displays, nothing will happen because another level exists below this selection. Press DOWN and the "Current" option displays. To cycle through the choices (Current, Factory, Power-Up, etc.), press the NEXT or PREV keys. Press ENTER and the selected configuration will print.

The Configurations

A configuration consists of a group of parameters, such as line spacing, forms length, etc. Your printer contains the following configurations:

- The factory default configuration. It can be loaded, but cannot be altered. All of the parameters and their values are listed on page 50.
- Eight configurations that you can customize for unique print job requirements. Creating customized configurations is explained on page 54.

Locking And Unlocking The ENTER Key

To make configuration changes, you must unlock the ENTER key. With the printer offline, raise the printer cover and press the UP and DOWN keys simultaneously. The LCD will show this message for about a second:

ENTER SWITCH
UNLOCKED

When you lock the ENTER key, your configuration settings are fixed and cannot be altered. (Locking secures your settings.)

With the printer offline, raise the printer cover and press the UP and DOWN keys simultaneously to lock the ENTER key. The LCD will briefly show this message:

ENTER SWITCH
LOCKED

Changing And Saving Parameter Settings

You can change a parameter setting, such as line spacing or forms length, by pressing keys on the control panel or by sending emulation control codes in the host data stream.

When you change a parameter, it is active as long as the printer is on. This is true whether you used the control panel or sent a control code from the host.

If you use the control panel, you can save the parameters as a customized configuration. A configuration consists of a group of parameters. A saved configuration will not be lost if you turn off the printer.

You can change a parameter with a control code, but to save the parameter setting you must use the control panel.

Control codes override control panel parameters. For example, if you set the line spacing to 6 lpi with the control panel, and application software later changes this to 8 lpi with a control code, the control code setting overrides the control panel setting.

The 8 lpi parameter is effective as long as the printer is on. If you turn off the printer, the 8 lpi parameter will be erased. To save the parameter, you must use the control panel and save it as a configuration.

You can save up to eight configurations.

Changing parameters is described on page 54, and saving configurations is described on page 56.

Factory Default Configuration Values

The factory default values are permanently stored in memory as a configuration and cannot be modified or erased. The configuration values for the Bi-Tronics parallel interface and NIC interface are displayed on the following pages.

Bi-Tronics Parallel Interface

ACTIVE EMULATION	PCL-II
PCL-II	
Primary Char. set	
ID	0
Symbol Set	Roman-8 [8U]
Pitch	10.00
Density	Data Processing
Second Char. set	
ID	0
Symbol Set	Roman-8 [8U]
Pitch	10.00
Density	Data Processing
Page Length Rep.	Inches/Page
Max. Line Width	13.2 inches
Face, CPI Delay	Enable
Graphics Density	60 DPI
Perforation Skip	Disable
Display Functns	Disable
Line Terminator	
LF After CR	Disable
CR After LF	Disable
CR after FF	Disable
CR After VT	Enable
PTX Linefeed	Disable
LPI Adjust	6 LPI
Page L./Lines	66 Lines
Page L./Inches	11.0 Inches
Config. Print	
Symbol Set Print	
Reset Cmd CFG Ld	Power Up Config
LP PLUS	
Printer Protocol	
P-Series	
Control Code 06	8.0 LPI
Control Code 08	Elongated
Define CR Code	CR = CR
Auto LF	Disable
Overstrike	Enable
Define LF code	LF = CR + LF
Select SFCC	1
EVFU Select	Enable
Alt. Set 80-9F	Control Code
Character Set	
IBM PC	
Primary Subset	ASCII (USA)
Extended Subset	Code Page 437
SFCC d command	Even dot plot
CPI/LPI Select	
Select CPI	10.0 CPI
Select LPI	6.0 LPI

Font Attributes	
Typeface	Data Processing
Prop. Spacing	Disable
Bold Print	Disable
Italic Print	Disable
Slashed Zero	Disable
Page Format	
Form Length	
Abs. Length IN	11.0 inches
Abs. Length MM	279.4 mm
Funct. of lines	66 lines
Form Width	
Abs. Width IN	13.6 inches
Abs. Width MM	345.4 mm
Function of CPI	136 characters
Margins	
Left Margin	0 columns
Right Margin	0 columns
Bottom Margin	0 lines
Perforation Skip	Disable
MAINT / MISC	
Hex Dump Mode	Disable
Power-up State	Online
Display Language	English
Power Stacker	Enable
HOST INTERFACE	
Bi-Tronics	
Prime Signal	Disable
TOF Action	Reset
Buffer Size in K	1
PRINTER CONTROL	
Unidirectional	Disable
PMD Fault	Enable
Slow Paper Slew	Disable
Power Saver Time	15 min
DIAGNOSTICS	
Printer Tests	Shift Recycle
Test Width	Full Width
Paper Out Dots	40 dots
System Memory	x Megabytes
Print Statistics	
On:	x.x Hrs
Print:	x.x Hrs
Print Strokes	x
Print Lines	x
11 inch Pages	x
RIBBONMINDER	
New Ribbon	
Ribbon Action	Disable
Ribbon Size	60 yards
Ribbon Adjust	0
Fault Action	New Ribbon

NIC Interface

ACTIVE EMULATION	PCL-II
PCL-II	
Primary Char. set	
ID	0
Symbol Set	Roman-8 [8U]
Pitch	10.00
Density	Data Processing
Second Char. set	
ID	0
Symbol Set	Roman-8 [8U]
Pitch	10.00
Density	Data Processing
Page Length Rep.	Inches/Page
Max. Line Width	13.2 inches
Face, CPI Delay	Enable
Graphics Density	60 DPI
Perforation Skip	Disable
Display Functns	Disable
Line Terminator	
LF After CR	Disable
CR After LF	Disable
CR after FF	Disable
CR After VT	Enable
PTX Linefeed	Disable
LPI Adjust	6 LPI
Page L./Lines	66 Lines
Page L./Inches	11.0 Inches
Config. Print	
Symbol Set Print	
Reset Cmd CFG Ld	
LP PLUS	Power Up Config
Printer Protocol	
P-Series	
Control Code 06	8.0 LPI
Control Code 08	Elongated
Define CR Code	CR = CR
Auto LF	Disable
Overstrike	Enable
Define LF code	LF = CR + LF
Select SFCC	1
EVFU Select	Enable
Alt. Set 80-9F	Control Code
Character Set	
IBM PC	
Primary Subset	ASCII (USA)
Extended Subset	Code Page 437
SFCC d command	Even dot plot
CPI/LPI Select	
Select CPI	10.0 CPI
Select LPI	6.0 LPI
Font Attributes	
Typeface	Data Processing
Prop. Spacing	Disable
Bold Print	Disable
Italic Print	Disable
Slashed Zero	Disable

Page Format	
Form Length	
Abs. Length IN	11.0 inches
Abs. Length MM	279.4 mm
Funct. of lines	66 lines
Form Width	
Abs. Width IN	13.6 inches
Abs. Width MM	345.4 mm
Function of CPI	136 characters
Margins	
Left Margin	0 columns
Right Margin	0 columns
Bottom Margin	0 lines
Perforation Skip	Disable
MAINT / MISC	
Hex Dump Mode	Disable
Power-up State	Online
Display Language	English
Power Stacker	Enable
HOST INTERFACE	
Ethernet	
Buffer Size in K	1
ETHERNET PARAMS	
IP Address	xxx.xxx.xxx.xxx
Gateway Address	xxx.xxx.xxx.xxx
Subnet Mask	xxx.xxx.xxx.xxx
MAC Address	hhhhhhhhhhhh
Novell Protocol	Disable
NetBIOS Protocol	Disable
Novell Frame	Ethernet 802.2
PPM Port Number	3001
PPM Port Timeout	100 seconds
Ethernet Speed	Auto Select
PRINTER CONTROL	
Unidirectional	Disable
PMD Fault	Enable
Slow Paper Slew	Disable
Power Saver Time	15 min
DIAGNOSTICS	
Printer Tests	Shift Recycle
Test Width	Full Width
Paper Out Dots	40 dots
System Memory	x Megabytes
Print Statistics	
On:	x.x Hrs
Print:	x.x Hrs
Print Strokes	x
Print Lines	x
11 inch Pages	x
RIBBONMINDER	
New Ribbon	
Ribbon Action	Disable
Ribbon Size	60 yards
Ribbon Adjust	0
Fault Action	New Ribbon

Changing Parameters

A configuration consists of several parameters. The factory configuration is PCL-II emulation using the Bi-Tronics interface. You can keep this configuration to print your jobs, or if your print job requires a different setting such as a serial interface, follow the procedure outlined in Table 6.

Example

The example below describes how to change the Unidirectional parameter from disable to enable. Use this example as a basic guideline to move throughout the configuration menu and change other parameters.

Figure 9 on page 47 shows the top level of the configuration menu. The submenus are shown in Chapter 4.

If the configuration has already been changed and you do not know what the current configuration is, print a copy (page 58). Then decide if you must change any parameters.

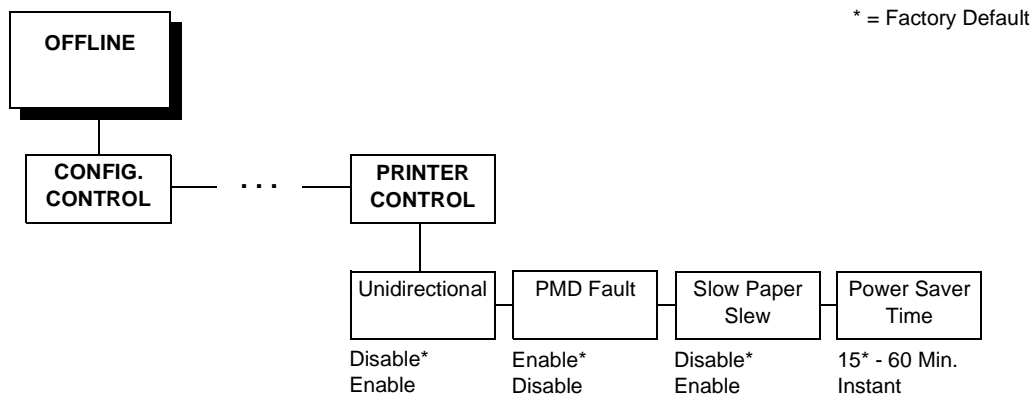

Note Once you change active emulations, any changes to the previously selected emulation will be gone unless they have been saved.

Table 6. Parameter Change Example Procedure











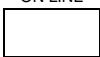



Step	Key	Result	Notes
1.			Make sure the printer is on. Raise the printer cover (on cabinet models).
2.	ON LINE 		

Table 6. Parameter Change Example Procedure (continued)

Step	Key	Result	Notes
3.	 + 	ENTER SWITCH UNLOCKED	Allows you to make configuration changes.
		OFFLINE CONFIG. CONTROL	
4.	 UNTIL	OFFLINE PRINTER CONTROL	
5.		PRINTER CONTROL Unidirectional	
6.		Unidirectional Disable*	
7.	 OR 	Unidirectional Enable	Cycle through the choices.
8.	ENTER 	Unidirectional Enable*	An asterisk (*) indicates this choice is active.
TO SAVE YOUR CHANGES AS A CONFIGURATION THAT IS STORED IN MEMORY:			
1.	 UNTIL	OFFLINE PRINTER CONTROL	
2.	 UNTIL	OFFLINE CONFIG. CONTROL	
3.	Go to the CONFIG. CONTROL submenu Save Config. option, as described on page 57.		
TO USE THE CURRENT CONFIGURATION WITHOUT SAVING:			
1.	 + 	ENTER SWITCH LOCKED	
2.	ON LINE 	ONLINE	
3.	On cabinet models, close the printer cover. The printer is ready for operation. All parameters are effective as long as the printer is on. When you turn off the printer, the parameters will be erased from memory.		

Saving Your New Configuration

* = Factory Default

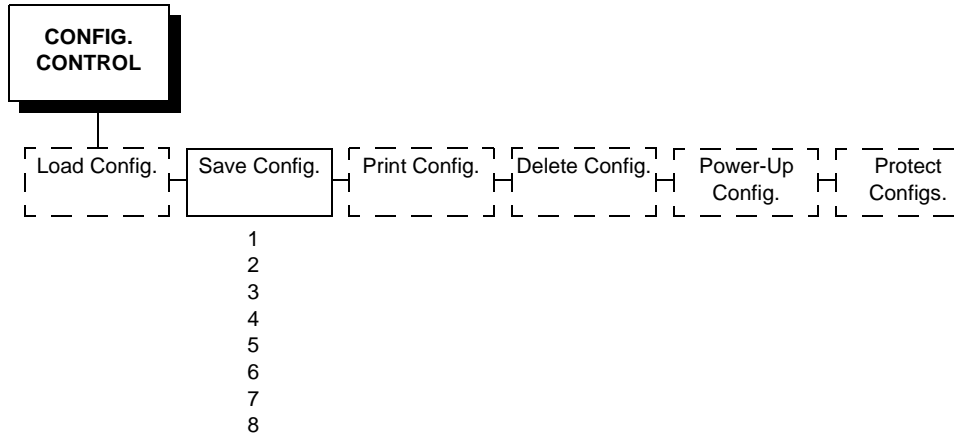

A configuration must be saved in order to load it later. You can save up to eight configurations to meet different print job requirements. For example:

Config 1: Selects Standard density, 10 CPI, 6 LPI, 11-inch forms

Config 2: Selects Sparse density, 10 CPI, 8 LPI, 8-inch forms













The configurations are saved and stored in memory; they will not be lost if you power off the printer. Later, you can load one of the configurations for a specific print job. This eliminates the need to change settings (LPI, forms length, etc.) for each new job. See page 60 for information about loading configurations. You may want to print your configurations (page 58) and store them in a safe place, such as inside the printer cabinet.

If you are going to change and save parameters for both the PCL-II and LinePrinter Plus emulations, remember to save the changes for the PCL-II emulation before you select LP Plus as the active emulation (page 79) or vice versa. Once you change active emulations, any changes to the previously selected emulation will be erased unless they have been saved.

If you do not save your configuration before you turn off the printer, all of the new parameters will be erased. When you turn the printer on again, the power-up configuration will load. If no configurations have been designated as the power-up configuration, the factory configuration will load.

If the Protect Configs. parameter is enabled, the new configuration will not be saved unless the existing configuration has been deleted. See page 66 for details.

Table 7. Saving Configurations

Step	Key	Result	Notes
1.	Make sure the printer is on. Raise the printer cover (on cabinet models).		
2.	ON LINE 	OFFLINE CONFIG. CONTROL	
3.	 + 	ENTER SWITCH UNLOCKED	Allows you to make configuration changes.
		OFFLINE CONFIG. CONTROL	
4.		CONFIG. CONTROL Load Config.	
5.	 UNTIL	CONFIG. CONTROL Save Config.	
6.		Save Config. 1*	
7.	 OR 	Save Config. 2	Press until the desired number (1-8) displays.
NOTE: Do not turn off the printer while save is in progress because you might lose your configuration.			
8.	ENTER 	Save Config. 2*	The configuration is now saved in memory. (In this case, config. 2.)
9.	 UNTIL	CONFIG. CONTROL Save Config.	
NOTE: It is recommended you print the configuration (see page 59 for the procedure). If you decide not to print the configuration, then continue with the following steps.			
10.	 + 	ENTER SWITCH LOCKED	Locks the ENTER key.
11.	ON LINE 	ONLINE	
12.	Close the printer cover. The printer is ready for operation.		

Printing The Current Configuration

* = Factory Default

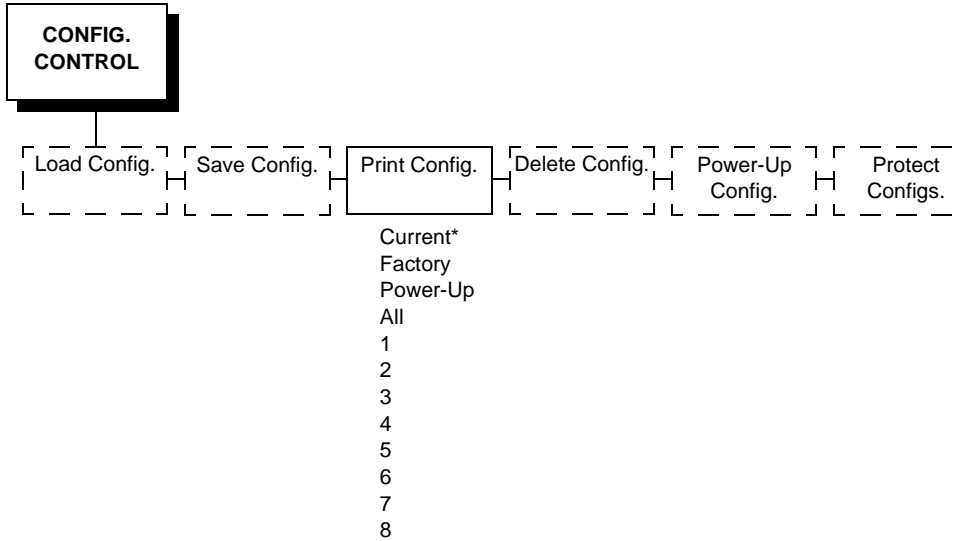









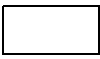

The configuration printout lists the stored parameters. You can print any or all of the configurations shown above. Configurations 1-8 are the customized configurations.

To print a configuration, follow the procedure in Table 8.

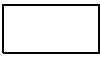

Note It is recommended that you print all of the configurations and store them in a safe place, such as inside the printer cabinet, for future reference.

Table 8. Printing Configurations

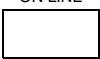
Step	Key	Result	Notes
1.			Make sure the printer is on. Raise the printer cover (on cabinet models).
2.	ON LINE 	OFFLINE CONFIG. CONTROL	
3.	 + 	ENTER SWITCH UNLOCKED	Allows you to make configuration changes.
		OFFLINE CONFIG. CONTROL	
4.		CONFIG. CONTROL Load Config.	
5.	 UNTIL	CONFIG. CONTROL Print Config.	
6.		Print Config. Current*	
7.	 OR 	Print Config. All	Press until the desired option displays.
8.	ENTER 	OFFLINE CONFIG. CONTROL	The configuration listing begins printing.
9.			Carefully tear off the configuration printout.
10.	 + 	ENTER SWITCH LOCKED	Locks the ENTER key.
11.	ON LINE 	ONLINE	
12.			Close the printer cover. Store the printout in a safe place. The printer is ready for operation.

Loading Configuration Values

* = Factory Default

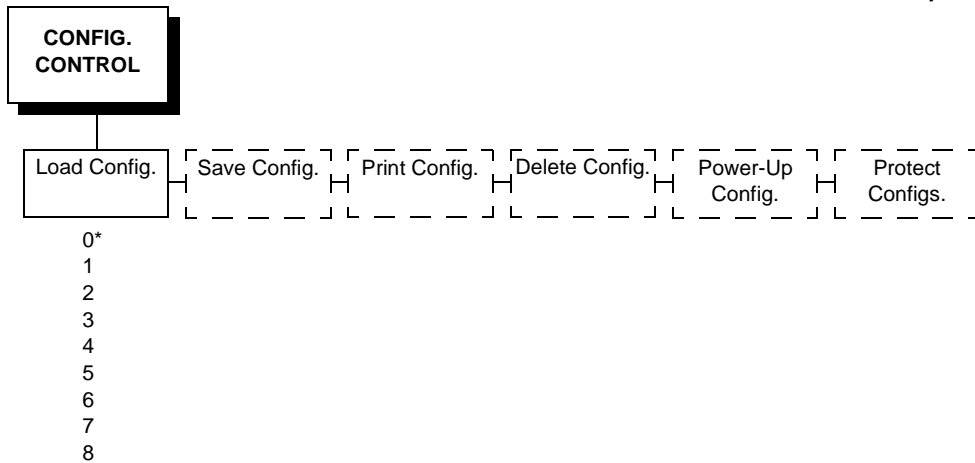

You can load any of the eight customized configurations or the factory default configuration, Configuration 0. Its list of parameters begins on page 50.

The loaded configuration remains active as long as the printer is on. If you power off the printer, the power-up configuration will load when power is turned back on. Any of the eight customized configurations can be designated as the power-up configuration.







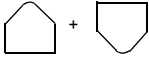

The procedure in Table 10 explains how to select the power-up configuration. If you do not set a power-up configuration, the factory default configuration will load if you power the printer off and then power it back on.

Note

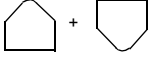

A configuration must be saved first in order to load it.

Table 9. Loading Configurations

Step	Key	Result	Notes
1.	Make sure the printer is on. Raise the printer cover (on cabinet models).		
2.	ON LINE 	OFFLINE CONFIG. CONTROL	
3.	 + 	ENTER SWITCH UNLOCKED	Allows you to make configuration changes.
		OFFLINE CONFIG. CONTROL	
4.		CONFIG. CONTROL Load Config.	
5.		Load Config. 1*	
6.	 OR 	Load Config. 4	Press until the desired number (1-8) displays.
7.	ENTER 	Loading Saved Configuration	Displays for about a second.
		Load Config. 4*	The printer has loaded the configuration.
8.	 + 	ENTER SWITCH LOCKED	Locks the ENTER key.
9.	ON LINE 	ONLINE	
10.	Close the printer cover. The printer is ready for operation.		

The Power-Up Configuration

* = Factory Default

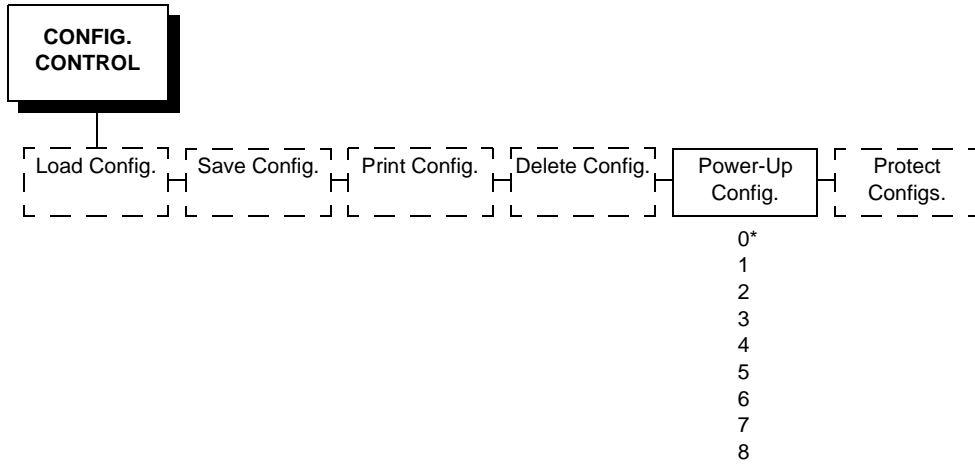













When you power on the printer for the first time, it loads configuration 0 which is the factory default configuration.

If you save a configuration, such as configuration 1, and turn the power off and then back on, the printer will load the designated power-up configuration, not the last saved configuration.

For your convenience, you can specify which configuration (0-8) should be the power-up configuration.

Table 10. Setting The Power-Up Configuration

Step	Key	Result	Notes
1.	Make sure the printer is on. Raise the printer cover (on cabinet models).		
2.	ON LINE 	OFFLINE CONFIG. CONTROL	
3.	 + 	ENTER SWITCH UNLOCKED	Allows you to make configuration changes.
		OFFLINE CONFIG. CONTROL	
4.		CONFIG. CONTROL Load Config.	
5.	 UNTIL	CONFIG. CONTROL Power-Up Config.	
6.		Power-Up Config. 0*	
7.	 OR 	Power-Up Config. 6	Press until the desired number (1-8) displays.
8.	ENTER 	Power-Up Config. 6*	The printer has selected the desired configuration.
9.	 + 	ENTER SWITCH LOCKED	Locks the ENTER key.
10.	ON LINE 	ONLINE	
11.	Close the printer cover. The printer is ready for operation.		

Deleting Configurations



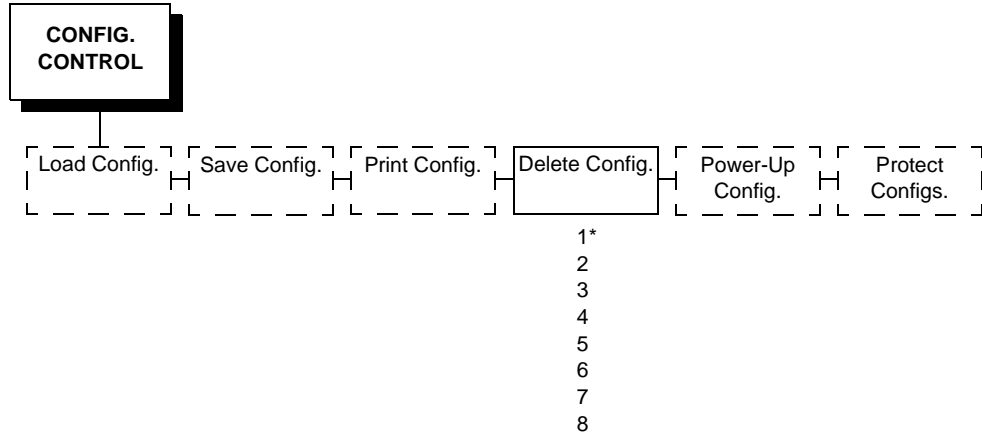





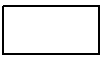

* = Factory Default



You can delete any of your customized configurations. You cannot, however, delete the configuration 0, which is the factory preset configuration.

The Protect Configs. parameter must be set to disable before you may delete a configuration (see page 66).

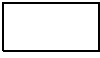
Table 11. Deleting Configurations

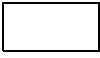
Step	Key	Result	Notes
1.	Make sure the printer is on. Raise the printer cover (on cabinet models).		
2.	ON LINE 	OFFLINE CONFIG. CONTROL	
3.	 + 	ENTER SWITCH UNLOCKED	Allows you to make configuration changes.
		OFFLINE CONFIG. CONTROL	
4.		CONFIG. CONTROL Load Config.	
5.	 UNTIL	CONFIG. CONTROL Delete Config.	
6.		Delete Config. 1*	
7.	 OR 	Delete Config. 3	Press until the desired number (1-8) displays.
8.	ENTER 	Deleting Configuration	The printer has deleted the selected configuration.
		Delete Config. 3*	
9.	 + 	ENTER SWITCH LOCKED	Locks the ENTER key.
10.	ON LINE 	ONLINE	
11.	Close the printer cover. The printer is ready for operation.		

Protecting Your Configurations

* = Factory Default

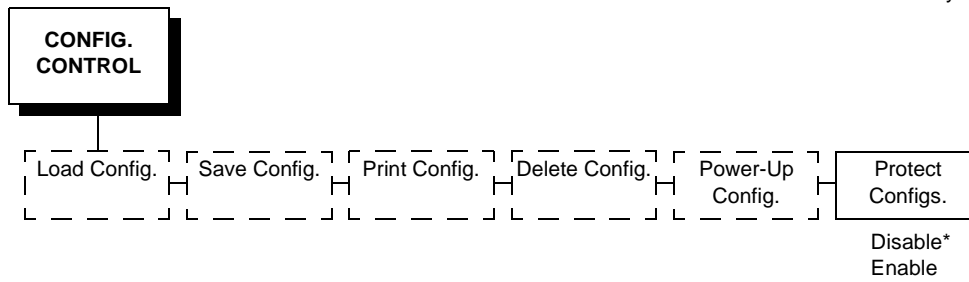

To save or delete a configuration you must set the Protect Configs. option to disable.

Configuring NIC

Connecting To The Network

To attach the NIC to a network, plug the network cable into the NIC connector (see Figure 10).

Watch the LEDs in the rear of the printer as they cycle through the power on self-test. When the test is complete, the STAT led will flash.

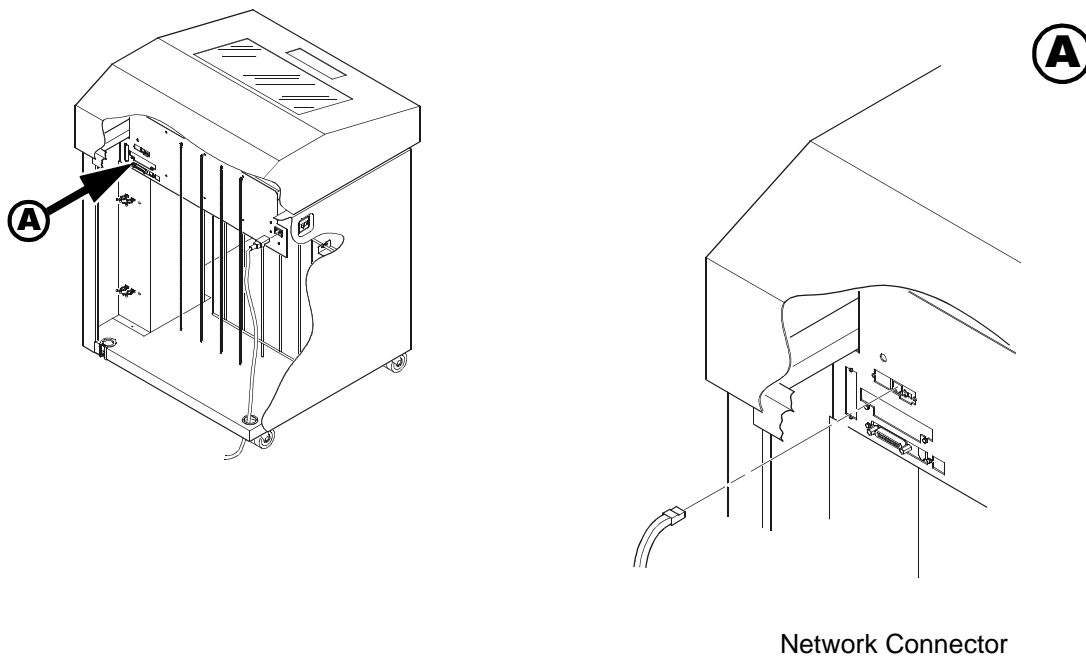

Figure 10. Physical Setup

Configuration Setup

There are two parts to a NIC setup:

1. Configuring the NIC so it can be seen on the network. This involves network related settings (e.g., an IP address within TCP/IP environments) configured through the built-in command shell, npsd, or from the control panel.
2. Configuring a host with a new printer so it knows how to send data to the NIC. Just being able to see the printer on the network does not mean you can automatically print to it. A host has to be told where to send the data.

Note

Some network environments do not require any network settings to be configured on the NIC. However, all network setups require configuration on the host end.

Configuration Using The Printer Control Panel

NIC settings can be set from the printer control panel. The procedure is described below.

Note

When the printer is first powered on, the messages “Waiting for the Ethernet Adapter” and “Ethernet Detected” will display on the LCD. After several other boot messages appear, the LCD will display the message “E-NET INIT.” This initialization process will take about two minutes. During that time, you will not be able to change any printer settings from the control panel. If you attempt to do so, the message “Please Wait E-NET INIT.” will appear. When the initialization is complete, the message “E-NET READY” will display, and you may then change any NIC or other printer configuration options from the control panel.

You can set any of three listed parameters from the printer control panel. These parameters are located in the ETHERNET PARAMS menu. The available parameters are:

- IP Address
- Gateway Address
- Subnet Mask

The procedure for changing any of the parameters is the same. The procedure for changing the IP Address is given here as an example. Use the same procedure for the other required parameters.

To change the IP Address parameter:

1. Make sure the printer is on and raise the printer cover.
2. Press the ON LINE key to place the printer in the OFFLINE mode.
3. Unlock the ENTER key. (For instructions, refer to “Locking And Unlocking The ENTER Key” on page 48.)
4. Press the LEFT or RIGHT arrow key until the LCD displays “ETHERNET PARAMS.”
5. Press the DOWN arrow key to access the “IP Address” parameter.
6. Press the DOWN arrow key to view the current IP Address.
7. Press the DOWN arrow key to access the portion of the IP Address to be changed.
8. Press the LEFT or RIGHT arrow key to select the portion of the IP Address to be changed.

9. Press the DOWN arrow key.
10. Press the LEFT or RIGHT arrow key to select the desired value.
11. Press the ENTER key to make the selection. An asterisk appears to the right of the value.
12. Press the UP arrow key and you will be returned to step 8. When you are finished changing parameters, exit the configuration menus and lock the ENTER key. (For instructions, refer to “Locking And Unlocking The ENTER Key” on page 48.)

Caution



When a change is made from the control panel, the NIC is re-initialized. The messages “E-NET RESET” and “E-NET INIT” display on the control panel. This process takes several minutes. Make sure not to shut the printer off or make further changes to the NIC settings during this initialization period to prevent a loss of NIC configuration information. When the initialization is complete, the message “E-NET READY” will display.

Configuration Alternatives

Besides the HTML forms and software provided, the NIC internal command shell, npsh, can also be reached using the following methods.

The Printronix Printer Manager (PPM)

The PPM utility is a versatile and dynamic program. It allows you to remotely organize all the printers in your office in a single database; download software and printer settings from a host computer with a single mouse click; and use a virtual operator's panel to configure printers in the same room or on the other side of the world.

Telnet

A TCP/IP command that helps configure NIC settings remotely. A TCP/IP host starts a Telnet session with the print server and logs in to the device command shell to alter and view settings.

Example:

```
telnet 192.75.11.9
```

Remote Shell

A TCP/IP command that helps configure print server settings remotely. A TCP/IP host uses this command to remotely execute a single command on the NIC.

Example:

```
rsh spike list prn
```

This command remotely executes the npsh command **list prn** on the NIC named **spike**.

Configuration Using a Web Browser

NIC settings can be configured over TCP/IP through a standard Web browser. The NIC Web pages provide a handy way to access some of the commands built into the print server. You can access online help for all HTML pages.

Note

If a router is used, make sure a gateway value is configured.

To access the NIC home page:

1. Make sure the print server has an IP address and subnet mask so it is recognizable on your TCP/IP network.
2. Make sure your network station can successfully **ping** the NIC over the network.
3. Direct your Web browser to the Uniform Resource Locator (URL) **http://IPaddress** (e.g., **http://192.75.11.9**). You will be able to determine the exact state of the printer from the printer status screen, as the shown in Figure 11.

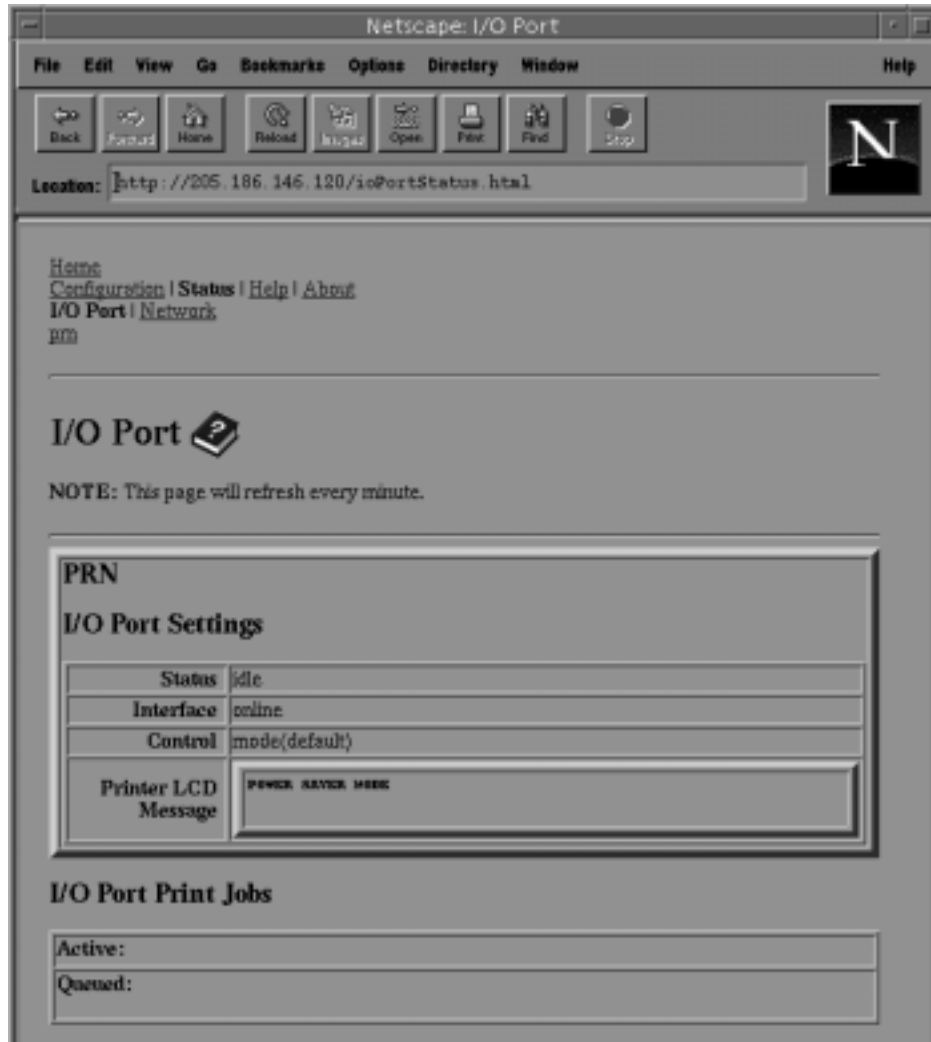

Figure 11. WWW Printer Status Screen

4

The Configuration Menus

Overview

Once you have familiarized yourself with the configuration process using the tutorial information in Chapter 3, you are ready to complete your configuration of the printer.

This chapter provides descriptions for each parameter provided by the configuration menus. Figure 12 shows the configuration main menu and its first level parameters. The remainder of this chapter includes illustrations of many additional submenus and parameters nested beneath each of the main menu options.

Configuration Main Menu

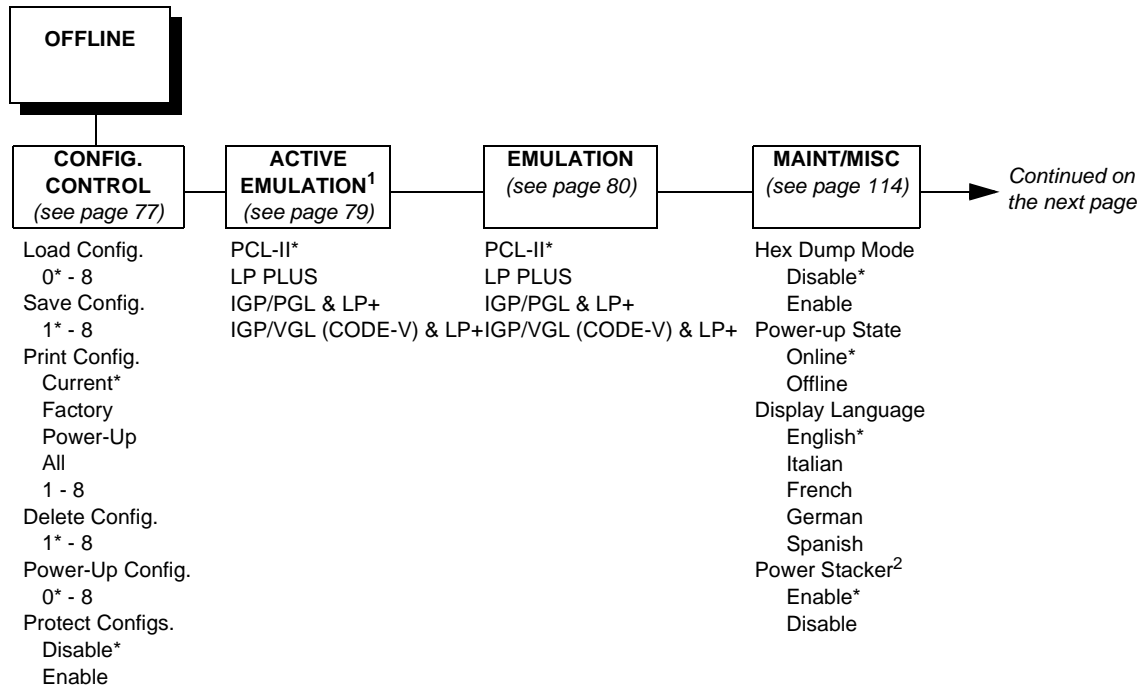

NOTES:

- ¹ Choices available are limited to the emulations configured with the printer.
- ² Appears only if the power stacker option is installed.

To view options, press:

- ▼ Down
- ▲ Up
- ▶ Next
- ◀ Prev

To select an option, press ENTER.

To return to main menu, press CLEAR.

To exit menu, press ON LINE.

* = Default Setting

Figure 12. Configuration Main Menu

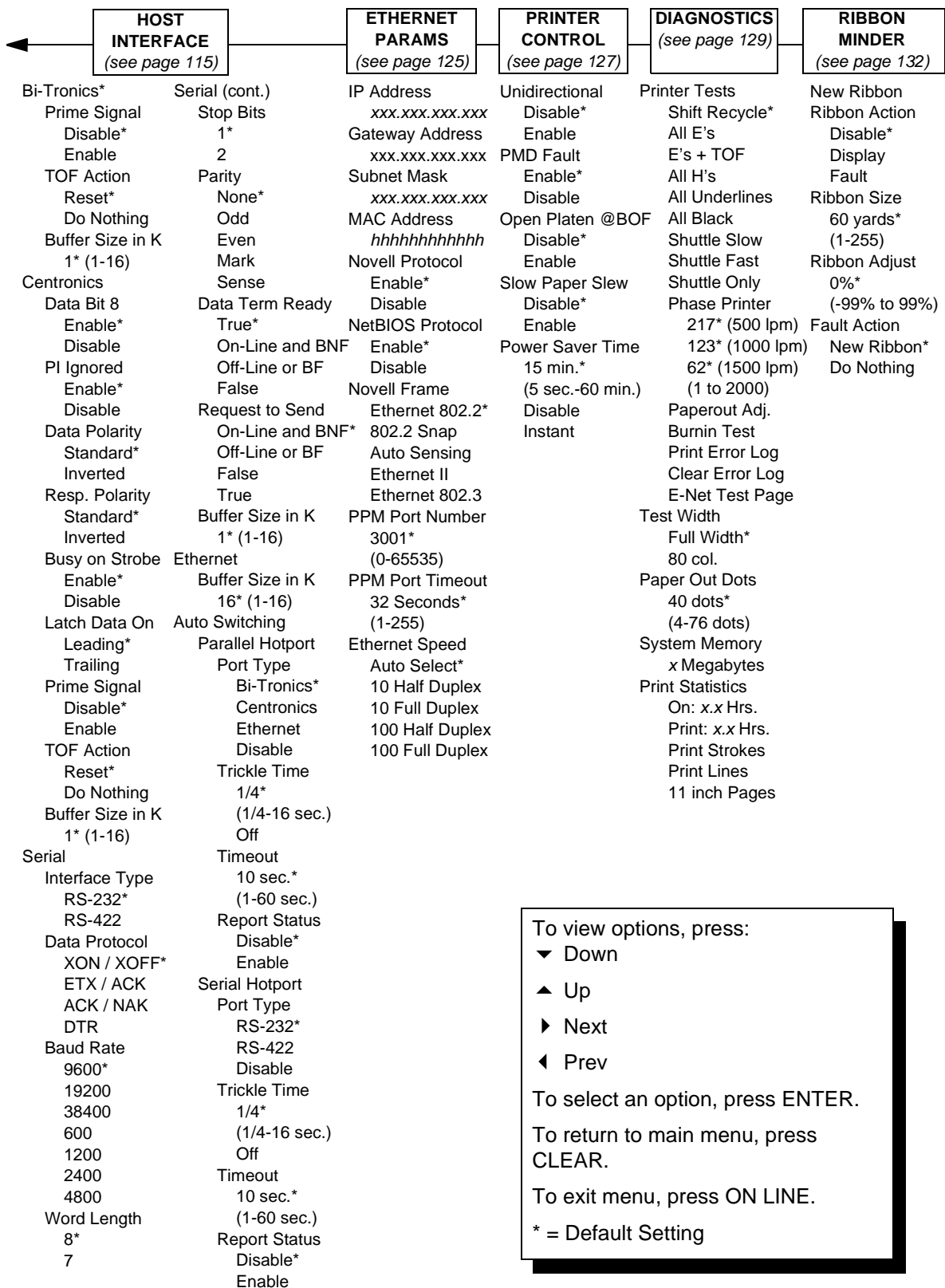
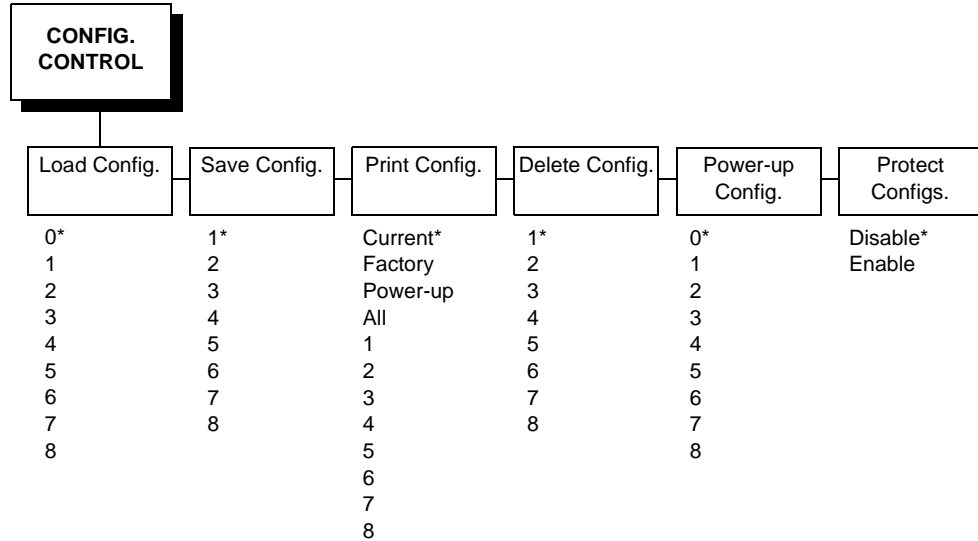

Figure 12. Configuration Main Menu (continued)

The first-level configuration menu options are briefly described below:

- **CONFIG. CONTROL.** Allows you to save, print, load, and delete entire sets of configuration parameters. These options are described briefly in this chapter and covered in detail in Chapter 3.
- **ACTIVE EMULATION.** Allows you to select either Hewlett-Packard's Printer Control Language (PCL-II) or LP Plus.
 - If you select PCL-II, you can select the optional IGP®/PGL® or IGP/VGL (Code V) emulations, if installed.
 - If you select LP Plus, you can select Epson FX, Proprinter XL, or P-Series.
- **EMULATION.** If PCL-II is the active emulation, PCL-II will display and you can select its parameters for configuration.
 - If the optional IGP/PGL or Code V emulations are installed, you can access their configuration parameters.
 - If LP Plus is the active emulation, Epson FX, Proprinter XL, and P-Series configuration parameters are available.
- **MAINT / MISC.** Provides miscellaneous functions, such as printing a hex dump, selecting a display language, and choosing whether the printer will power up offline or online.
- **HOST INTERFACE.** Allows you to select the printer interface depending on what type of interface cabling you installed while setting up your printer. In addition to selecting an active interface, this menu also allows you to configure several parameters for each interface.
- **ETHERNET PARAMS.** Allows you to view and change the IP Address, Gateway Address, and Subnet Mask. The MAC Address may also be viewed. In addition, Novell and Printer Manager options can be set.
- **PRINTER CONTROL.** Allows you to select several operating parameters for the printer, such as the speed at which paper will advance when FF (Form Feed) is pressed.
- **DIAGNOSTICS.** Includes the printer's diagnostic tests, system memory, and print statistics.
- **RIBBONMINDER.** Allows you to enable the RibbonMinder™ feature and set its parameters.

Config. Control Menu



To view options, press:

- ▼ Down
- ▲ Up
- ▶ Next
- ◀ Prev

To select an option, press ENTER.

To return to main menu, press CLEAR.

To exit menu, press ON LINE.

* = Default Setting

The CONFIG. CONTROL menu manages configurations, which are groupings of parameter values that can be stored in printer memory. Brief descriptions follow for each option.

Load Config.

The printer can store up to eight unique configurations in memory. This parameter allows you to select and load a specific configuration.

Configuration 0 is the factory default, and its parameters cannot be changed. It is always available for loading. See page 60 for a detailed description and sample procedure.

Save Config.

This option allows you to save up to eight unique configurations to meet different print job requirements, which eliminates the need to change the parameter settings for each new job.

The configurations are stored in memory. They will not be lost if you turn off the printer. Configuration 0 is a factory-preset configuration, which cannot be changed or saved. See page 56 for a detailed description and sample procedure.

Note

If the Protect Configs. parameter is enabled, the new configuration will not be saved unless the existing configuration has been deleted.

Print Config.

Allows you to print a listing of stored printer configurations. It is recommended you store the configurations in a safe place for quick referral, such as inside the printer, if you have a cabinet model. See page 58 for a detailed description and sample procedure.

Delete Config.

Allows you to delete one or all of your eight customized configurations. Configuration 0 is a factory-preset configuration and cannot be changed or deleted.

Power-Up Config.

Allows you to specify which of the nine configurations (0-8) will be the power-up configuration. The factory default for power-up is configuration 0. See page 62 for a detailed description and sample procedure.

Protect Configs.

Allows you to specify whether or not a new configuration should overwrite an existing configuration when you activate the Save Config. parameter.

- **Disable.** The default. The new configuration will overwrite the existing configuration.
- **Enable.** The new configuration will not overwrite the existing configuration, and the message “CONFIG. EXISTS / Delete First” displays. You must delete the existing configuration (1-8) before trying to save the new configuration.

Active Emulation Menu

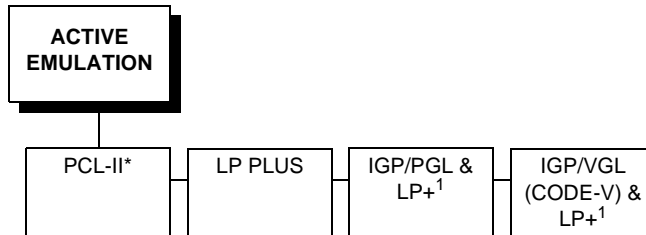

The ACTIVE EMULATION menu determines what emulations are available.

- **PCL-II.** The default. The PCL-II emulation is active.
- **LP PLUS.** Allows you to select LinePrinter Plus as the active emulation. If LP PLUS is the active emulation, you can select Epson, Proprinter III XL, or P-Series as the printer protocol (see page 86).
- **IGP/PGL & LP+ and IGP/VGL (Code V) & LP+.** The ACTIVE EMULATION function also allows you to activate either the PGL or the Code V emulation. There are two methods for selecting the desired emulation. The first is by selecting the emulation directly from the printer menu. The second is by sending a host command which will switch the emulation automatically. See the appropriate *Technical Reference Manual* for more information on these command codes.

When changing from one IGP emulation to the other, the printer will load the power-up configuration. Thus, any setting performed before selecting those emulations and not saved in flash memory will be lost.

For more information on IGP/PGL and Code V, see the appropriate *Technical Reference Manual*.

Note



To configure an IGP emulation, the IGP emulation must be selected in the ACTIVE EMULATION menu. The IGP emulation that is not selected will not appear in the EMULATION menu.

Emulation Menu

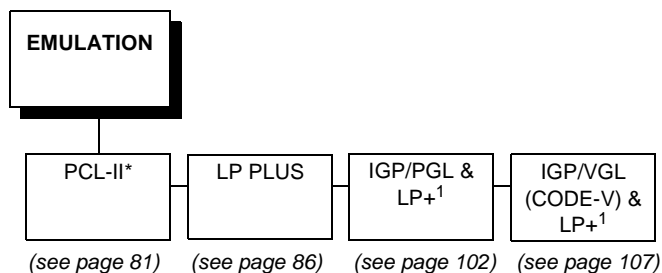

To view options, press:

▼ Down

▲ Up

▶ Next

◀ Prev

To select an option, press ENTER.

To return to main menu, press CLEAR.

To exit menu, press ON LINE.

* = Default Setting

¹ = If installed

The EMULATION menu is the gateway to configure the emulations available with the P5000LJ printer. The control codes for each of these emulations are described in their respective *Technical Reference Manuals*.

PCL-II Emulation

Hewlett-Packard's Printer Control Language that is compatible with Hewlett-Packard systems.

LP Plus Emulations

- **Epson FX.** This LP Plus emulation is provided for compatibility with the Epson FX-1050 printer control language.
- **Proprinter XL.** This LP Plus emulation is provided for compatibility with the IBM Proprinter III XL printer control language.
- **P-Series.** This is the Printronix P-Series printer control language, provided as part of LP Plus.

Optional Emulations

IGP/VGL (Code V) and IGP/PGL are optional graphics emulations. They can be selected and configured only if you have purchased these options. PCL-II must be the active emulation for Code V or IGP/PGL to operate.

PCL-II Emulation

* = Factory Default

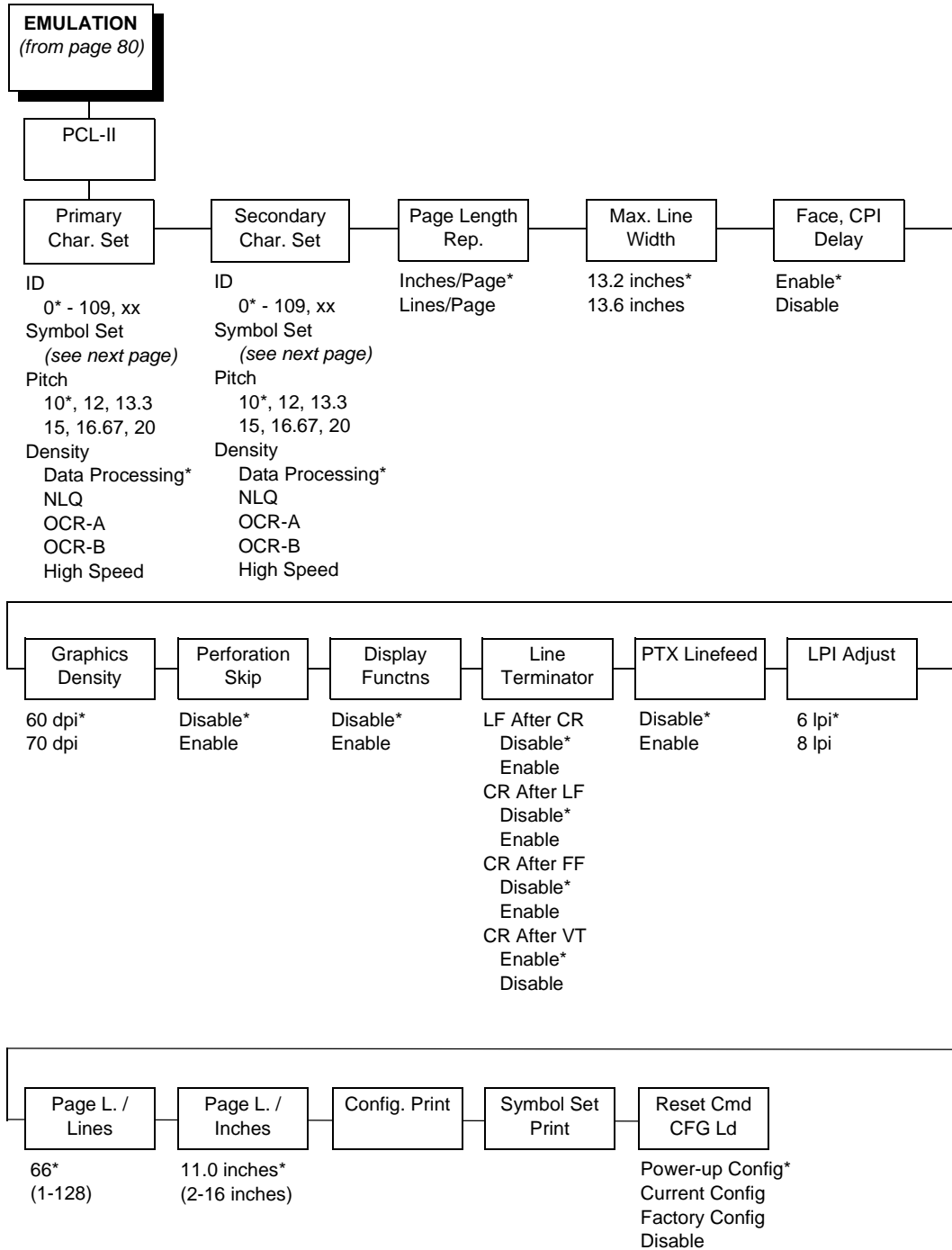

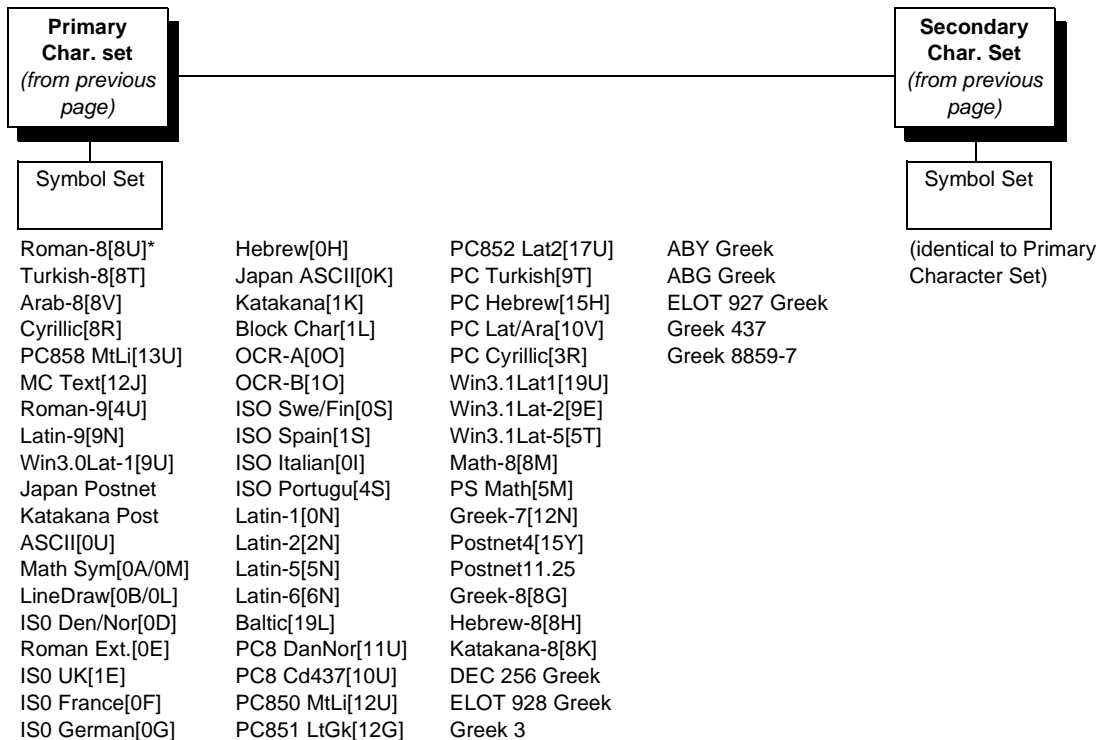

Primary Char. Set

You can select one of 92 pre-defined character sets by ID (although character sets range from 0 - 109, not all sets are available on the LJ500 printer), or you can select pitch, symbol set, and typeface individually. If the combination you choose matches one of the 92 predefined sets, the ID submenu will reflect that selection. If not, the ID menu will display xx to indicate that the current character set does not match a pre-defined set. Set 0 is the default, and its attributes are 10 cpi, Data Processing typeface, and Roman 8 symbol set.

Secondary Char. Set

Your printer can store an additional character set. To toggle between them, send the Shift In (Decimal 15, to select the Primary character set) or Shift Out (Decimal 14, to select the Secondary character set).

Page Length Rep.

- **Inches/Page.** All page length calculations are based on the inches displayed on the panel.
- **Lines/Page.** All changes in LPI or density will be changed accordingly. The length of the page is the number of lines per inch, or lpi.

For example, if the form in use is 82 lines at 6 lpi, the page is physically 13.67 inches. Since 13.67 inches is not selectable from the Length in Inches menu, change the representation to lines, then set the number of lines to 82. The inches menu will display 13.6 inches although the printer internally keeps the exact form length of 13.67 inches.

Max. Line Width

Set the maximum line width at 13.2 inches (the default) or 13.6 inches.

Face, CPI Delay

Allows the combination of different font densities on the same line.

- **Enable.** Different font densities can be used on the same line.
- **Disable.** Only the same font densities are allowed on the same line.

Graphics Density

Graphics can be printed in 60 DPI (the default) or 70 DPI.

Perforation Skip

- **Disable.** Allows printing on page perforation.
- **Enable.** You may set up a skip-over margin. For example, a skip-over margin of one inch creates a one inch margin at the bottom of the page.

Display Functns

- **Disable.** The default. Control characters are not printed.
- **Enable.** Control characters are printed before they get executed. This is a useful debugging tool.

Line Terminator

You can specify what will be used to indicate the end of a line. Four options are available: LF after CR, CR after LF, CR after FF, and CR after VT. Each of these options may be enabled or disabled independent of one another.

PTX Linefeed

- **Disable.** The default. Linefeed is to be performed as calculated from the bottom of the graphics or barcode, thereby disrupting the vertical text alignment.
- **Enable.** The Linefeed moves to the next line as calculated from the Top of Form position, thereby retaining vertical text alignment. When printing graphics or bar codes, you may want to set the PTX Linefeed parameter to Enable to maintain text alignment.

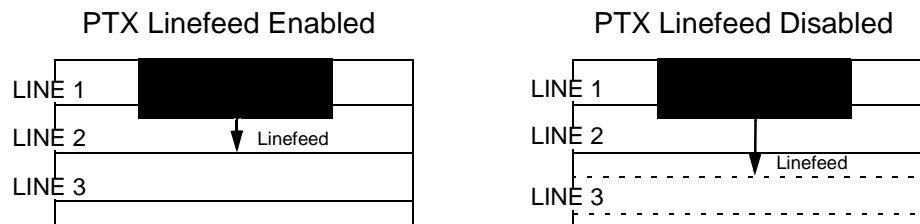

LPI Adjust

This parameter lets you specify the lines per inch (lpi) values: 6 LPI (the default) or 8 LPI.

Page L. /Lines

This parameter lets you set physical page length in lines from 12 to 96 at 6 lpi, or 16 to 128 at 8 cpi. The default is 66 lines at 6 lpi.

Note



If 6 lpi is selected, you will be able to scroll the menu to 128 (an invalid length). However, when you press ENTER to select this value, the menu will return with the maximum lines for 6 lpi (i.e., 96 lines). Similarly, selecting too few lines for 8 lpi will cause the menu to return with 16 lines.

Page L. /Inches

This parameter allows you to set physical page length from 2 to 16 inches, in increments of half an inch. The default is 11 inches.

Config. Print

This option prints the emulation's parameters and the currently selected values.

Symbol Set Print

This option prints a list of all the available sets. The character set number prints to the left of the character set sample.

Reset Cmd CFG Ld

When the printer receives a host data stream reset command in addition to resetting printer variables, the selected configuration will be loaded.

- **Disable.**

The printer ignores the reset command when it is received and continues to use the currently loaded configuration.
- **Power-Up Config.**

The power-up configuration is loaded when the reset command is received.
- **Current Config.**

If you have preset and presaved multiple configurations, then the currently selected presaved configuration is loaded when the reset command is received.
- **Factory Config.**

The factory installed configuration is loaded when the reset command is received.

LP Plus Emulation

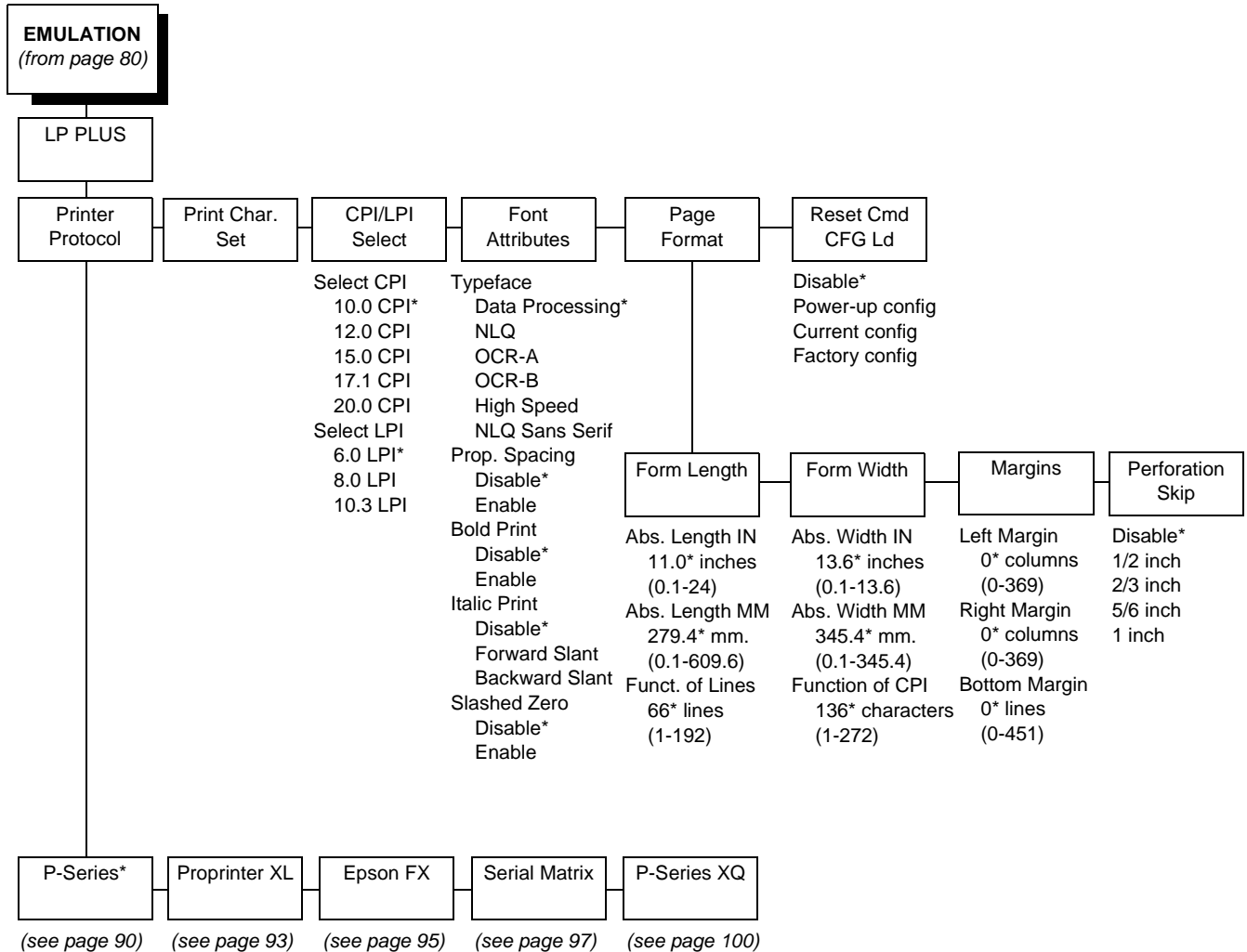

To view options, press:

- ▼ Down
- ▲ Up
- ▶ Next
- ◀ Prev

To select an option, press ENTER.

To return to main menu, press CLEAR.

To exit menu, press ON LINE.

* = Default Setting

Printer Protocol

Select the LinePrinter+ protocol you wish to use. Refer to the *PCL-III/LinePrinter Plus Technical Reference Manual* for more information.

Print Char. Set

When this selection is displayed and the ENTER key is pressed, the current character set is printed.

CPI/LPI Select

This parameter lets you specify the characters per inch (cpi) value and lines per inch (lpi) value.

Font Attributes

Typefaces

- **Data Processing.** A general purpose font printing out at 120 dpi horizontally and 72 dpi vertically. The width of the font will vary with each cpi.
- **NLQ.** A high quality font printing at 180 dpi horizontally and 96 dpi vertically. This font has serifs, and the width of the font varies with the cpi.
- **OCR-A / OCR-B.** Optical character recognition fonts printing at 120 dpi horizontally and 144 dpi vertically. Both fonts print only at 10 cpi.
- **High Speed.** A draft quality font printing at 120 dpi horizontally and 48 dpi vertically. The width of the font varies with the cpi.
- **NLQ Sans Serif.** A high quality font printing at 180 dpi horizontally and 96 dpi vertically. This font prints without serifs. The width of the font varies with the cpi.

Prop. Spacing

Each printed character is contained inside a character cell. The width of the character cell includes the character and the space around the character.

- **Disable.** Each character cell is printed with the same width. Each column in the printed text will line up.

```
This example is printed with
proportional spacing disabled.
```

- **Enable.** The width of each character cell varies with the width of the character. For example, [i] takes less space to print than [m]. Using proportionality generally increases the readability of printed documents, giving text a typeset appearance.

```
This example is printed with
proportional spacing enabled.
```

Bold Print

- **Disable.** Text is printed normally.
- **Enable.** Text is printed with a heavy line thickness.

Italic Print

- **Disable.** Text is printed normally.
- **Forward Slant.** Text is printed with a forward slant.
- **Backward Slant.** Text is printed with a backward slant.

Slashed Zero

This parameter allows you to print the numeral “0” with or without the slash. This option applies to all character sets except OCR-A and OCR-B.

- **Disable.** Zero is printed without a slash.
- **Enable.** Zero is printed with a slash.

Page Format

Forms Length

Forms length is the number of lines that can be printed on a page. You can set forms length in inches, millimeters (mm) or as a function of the current LPI (lines per inch).

Forms Width

The forms width can be specified in inches, millimeters, or as a function of the current CPI (characters per inch). The forms width set should not exceed the actual paper width.

Margins

- **Right Margin.** Set in columns. Column zero is defined as the far right edge of the page, and column numbering increments from right to left.
- **Left Margin.** Set in columns. Column zero is defined as the far left edge of the page, and column numbering increments from left to right.
- **Bottom Margin.** Defined in lines, starting from line zero at the bottom of the page and incrementing from the bottom up.

Perforation Skip

- **Disable.** Allows printing on page perforation.
- You may set up a skip-over margin of 1/2 inch, 2/3 inch, 5/6 inch, or 1 inch. For example, a skip-over margin of 1 inch allows a 1 inch margin at the bottom of the page.

Reset Cmd CFG Ld

When the printer receives a host data stream reset command in addition to resetting printer variables, the selected configuration will be loaded.

- **Disable.**

The printer ignores the reset command when it is received and continues to use the currently loaded configuration.

- **Power-Up Config.**

The power-up configuration is loaded when the reset command is received.

- **Current Config.**

If you have preset and presaved multiple configurations, then the currently selected presaved configuration is loaded when the reset command is received.

- **Factory Config.**

The factory installed configuration is loaded when the reset command is received.

P-Series Emulation

* = Factory Default

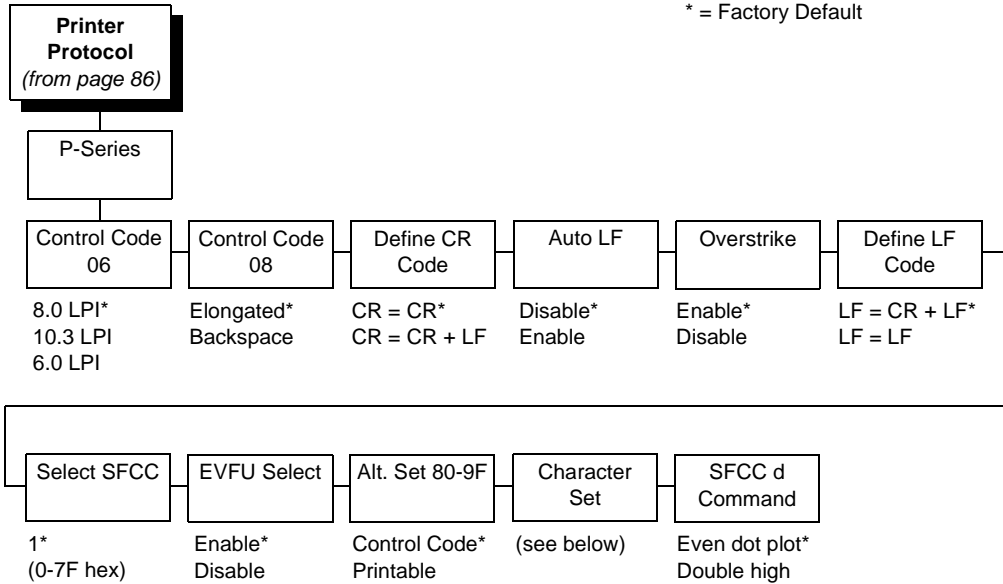

Character Set (from above)

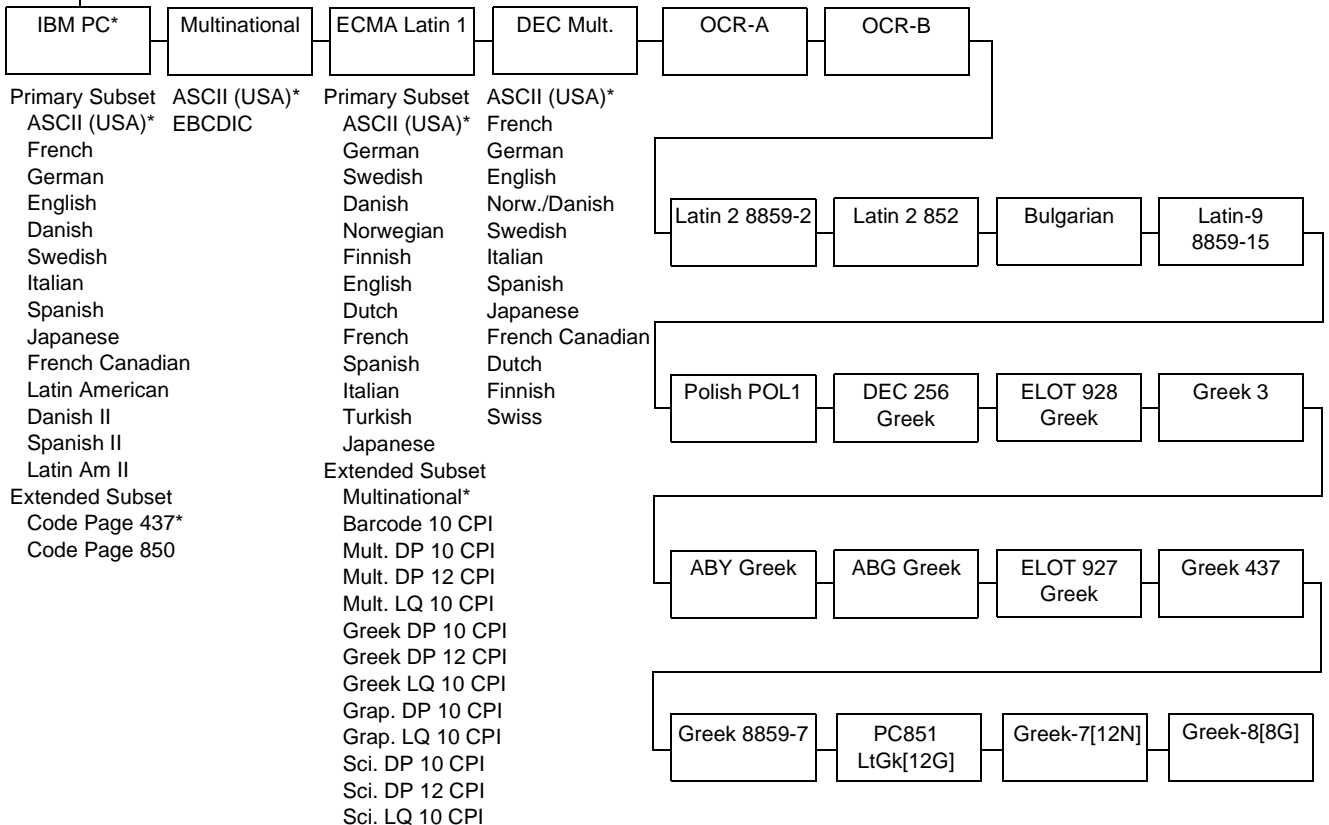

Control Code 06

Control Code 06 defines the function of ASCII code hex 06 (ACK). You can select an alternate line spacing of 6, 8, or 10.3 LPI.

Control Code 08

Control Code 08 defines the function of ASCII code hex 08 (BS). You can define the code to output an elongated character or a backspace.

Define CR Code

This option controls the action of the printer when it receives a Carriage Return code (hex 0D) from the host computer. If this feature is enabled, each time the printer receives a Carriage Return, it inserts an additional Line Feed code (hex 0A) into the data stream. Do not use this feature if the host computer sends Line Feeds to the printer.

- **CR = CR.** Does not insert an extra Line Feed after each Carriage Return.
- **CR = CR + LF.** Inserts an extra Line Feed after each Carriage Return. The next print position will be print position 1 of the next line.

Auto LF

This option defines the printer action when print data is received past the forms width setting.

- **Disable.** Discards any data past the forms width.
- **Enable.** Performs an automatic carriage return and line feed when data is received past the forms width.

Overstrike

This option enables you to print bold characters.

- **Enable.** Turns on bold print. When enabled, overstrike printing slows down the printer.
- **Disable.** Turns off bold print.

Define LF Code

- **LF = CR + LF.** Forces an automatic carriage return with each line feed command. The next print position is print position 1 of the next line.
- **LF = LF.** Does not perform an automatic carriage return. The next print position will be the current print position of the next line.

Select SFCC

This parameter allows you to select which ASCII codes will function as the Special Function Control Code (SFCC) command delimiter. P-Series codes can use hex 00 through hex 7F. Options include the following:

- ESC (hex 1B)
- SOH (hex 01)
- ETX (hex 03)
- CIRCUMFLEX (hex 5E)—also called caret (^)
- TILDE (hex 7E)—(~)

Note

SOH, ETX and ESC are non-printables. The characters (^) and (~) are printable. However, do not use them as printables in the host data stream if either is chosen as a delimiter, because print errors will occur.

EVFU Select

Controls how the printer handles vertical formatting.

- **Enable.** Enables the VFU and selects P-Series compatible Electronic Vertical Format Unit (EVFU).
- **Disable.** Disables VFU processing.

Alt. Set 80-9F

Determines whether the printer processes ASCII codes hex 80 through hex 9F as control codes or as printable characters.

Character Set

Specifies a character set as shown in the character set menu. To use one of these sets, choose the desired group heading (such as Multinational) and press ENTER. Then choose the desired set within that group (such as EBCDIC) and press ENTER. Both the group and the desired set name will include an asterisk to indicate your selection.

SFCC d Command

- **Even dot plot.** This option interprets SFCC d Command as even dot plot.
- **Double high.** This option interprets SFCC d Command as double high. Select this option for backward compatibility.

Proprinter XL Emulation

* = Factory Default

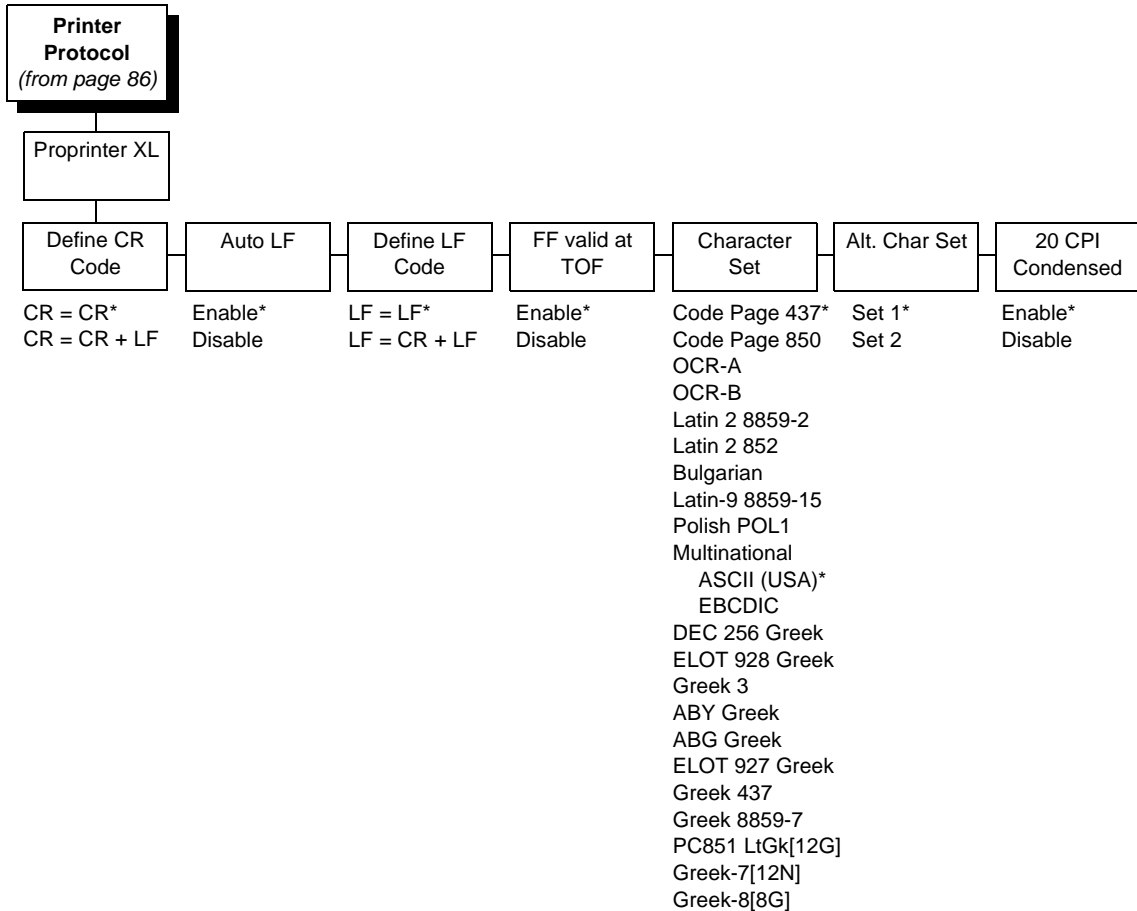

Define CR Code

This option controls the action of the printer when it receives a Carriage Return code (hex 0D) from the host computer. If this feature is enabled, each time the printer receives a Carriage Return, it inserts an additional Line Feed code (hex 0A) into the data stream. Do not use this feature if the host computer sends Line Feeds to the printer.

- **CR = CR.** Does not insert an extra Line Feed after each Carriage Return.
- **CR = CR + LF.** Inserts an extra Line Feed after each Carriage Return.

Auto LF

This option defines the printer actions when print data is received past the forms width setting.

- **Enable.** Performs an automatic carriage return and line feed when data is received past the forms width.
- **Disable.** Discards any data past the forms width.

Define LF Code

- **LF = LF.** Does not perform an automatic carriage return when a line feed command is received. The next print position will be the current print position of the next line.
- **LF = CR + LF.** Forces an automatic carriage return with each line feed command received. The next print position is print position 1 of the next line.

FF Valid at TOF

- **Enable.** Performs a form feed when the host sends a Form Feed command and the printer is at the top of form.
- **Disable.** Will not perform a form feed when the host sends a Form Feed command and the printer is at the top of form.

Character Set

Specifies a character set as shown in the menu. To use one of these sets, choose the desired character set and press ENTER. The desired set will be marked with an asterisk to indicate your selection.

Alt. Char Set

This option determines if data in the range of hex 80 through hex 9F should be interpreted as a control code or as a printable character.

- **Set 1.** Interprets data in the range of hex 80 through hex 9F as a control code.
- **Set 2.** Prints data for the characters at hex locations 03, 04, 05, 06, 15, and 80 through 9F.

20 CPI Condensed

Condensed print characters are narrower than the normal character set. This is helpful for applications for which you need to print the maximum amount of information on a page.

- **Enable.** Prints characters about 60 percent the width of normal characters when condensed print is chosen by the host computer.
- **Disable.** Does not condense print widths, even if condensed print is chosen by the host.

Epson FX Emulation

* = Factory Default

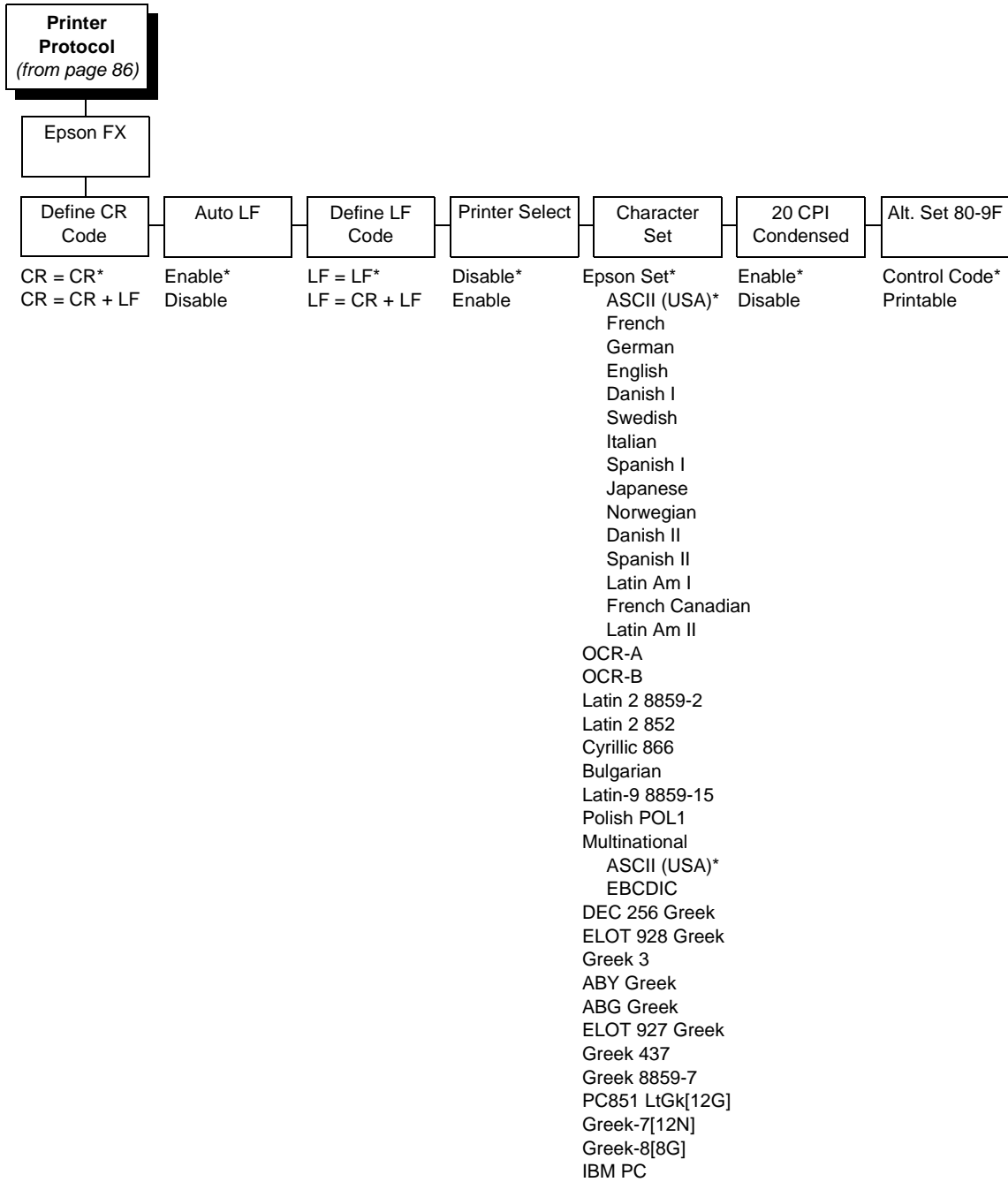

Define CR Code

The Define CR Code option controls the action of the printer when it receives a Carriage Return code (hex 0D) from the host computer. If this feature is enabled, each time the printer receives a Carriage Return, it inserts an additional Line Feed code (hex 0A) into the data stream. Do not use this feature if the host computer sends Line Feeds to the printer.

- **CR = CR.** Does not insert an extra Line Feed after each Carriage Return.
- **CR = CR + LF.** Inserts an extra Line Feed after each Carriage Return.

Auto LF

This option defines the printer actions when print data is received past the forms width setting.

- **Enable.** Performs an automatic carriage return and line feed when data is received past the forms width.
- **Disable.** Discards any data past the forms width.

Define LF Code

The Define LF Code option controls the action of the printer when it receives a Line Feed code (hex 0A) from the host computer. If this feature is enabled, each time the printer receives a Line Feed, it inserts an additional Carriage Return code (hex 0D) into the data stream. This feature is required if the host computer does not send Carriage Returns to the printer.

- **LF = LF.** Does not add a Carriage Return with a Line Feed.
- **LF = CR + LF.** Adds an extra Carriage Return with each Line Feed.

Printer Select

- **Disable.** Ignores the ASCII DC1 and DC3 control codes.
- **Enable.** Disables the printer when a DC1 control code is received, and enables the printer when a DC3 control code is received.

Character Set

This parameter selects a character set for the Epson emulation, as shown in the Character Set menu. Note that when OCR-A or OCR-B is selected as the print language, the Font Attribute Typeface option under the LinePrinter Plus menu (page 86) is changed to OCR-A or OCR-B, respectively.

20 CPI Condensed

Condensed print characters are narrower than the normal character set. This is helpful for applications for which you need to print the maximum amount of information on a page.

- **Enable.** Prints about 60 percent of the width of normal characters when condensed print is chosen by the host computer. For example, a 12 CPI Draft font will condense to 20 CPI.
- **Disable.** Does not condense print widths, even if condensed print is chosen by the host.

Alt. Set 80-9F

- **Control Code.** Interprets data in the range of hex 80 through hex 9F as a control code.
- **Printable.** Prints data in the range of hex 80 through hex 9F.

Serial Matrix Emulation

* = Factory Default

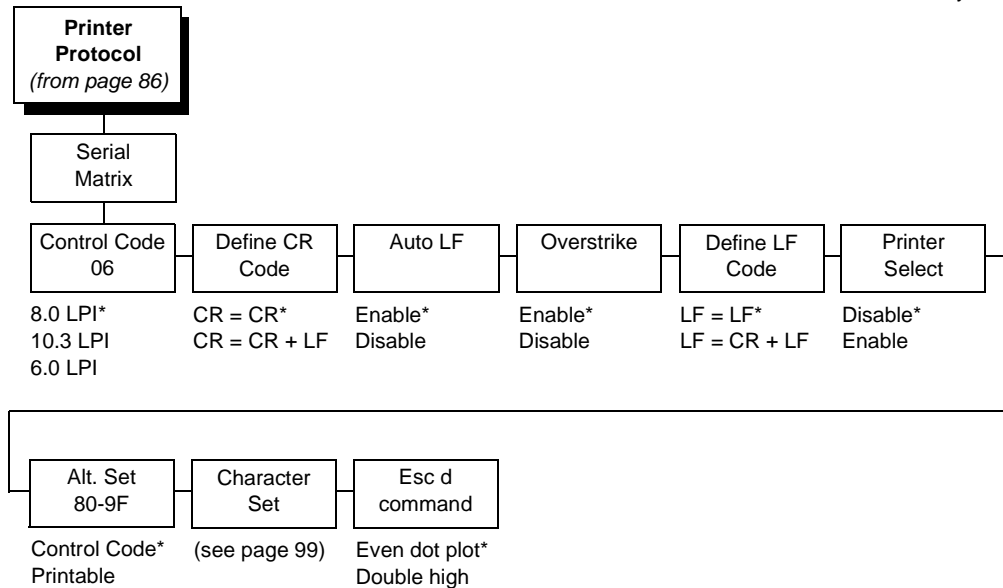

Control Code 06

Control Code 06 defines the function of ASCII code hex 06 (ACK). You can select an alternate line spacing of 6, 8, or 10.3 LPI.

Define CR Code

This option controls the action of the printer when it receives a Carriage Return code (hex 0D) from the host computer. If this feature is enabled, each time the printer receives a Carriage Return, it inserts an additional Line Feed code (hex 0A) into the data stream. Do not use this feature if the host computer sends Line Feeds to the printer.

- **CR = CR.** Does not insert an extra Line Feed after each Carriage Return.
- **CR = CR + LF.** Inserts an extra Line Feed after each Carriage Return. The next print position will be print position 1 of the next line.

Auto LF

The Auto LF option defines the printer actions when print data is received past the forms width setting.

- **Enable.** Performs an automatic carriage return and line feed when data is received past the forms width.
- **Disable.** Discards any data past the forms width.

Overstrike

This option enables you to print bold characters.

- **Enable.** Turns on bold print. When enabled, overstrike printing slows down the printer.
- **Disable.** Turns off bold print.

Define LF Code

- **LF = LF.** Does not perform an automatic carriage return when a line feed command is received. The next print position will be the current print position of the next line.
- **LF = CR + LF.** Forces an automatic carriage return with each line feed command received. The next print position is print position 1 of the next line.

Printer Select

- **Disable.** Ignores the ASCII DC1 and DC3 control codes.
- **Enable.** Disables the printer when a DC1 control code is received, and enables the printer when a DC3 control code is received.

Alt. Set 80-9F

- **Control Code.** Interprets data in the range of hex 80 through hex 9F as a control code.
- **Printable.** Prints data in the range of hex 80 through hex 9F.

Character Set

Specifies a character set as shown in the “Serial Matrix Character Set Menu” on page 99. To use one of these sets, choose the desired group heading (such as European Sets) and press ENTER. Then choose the desired set within that group (such as Roman 8) and press ENTER. Both the group and the desired set name will include an asterisk to indicate your selection. Character sets are shown in detail in the *Character Sets Reference Manual*.

ESC d Command

- **Even dot plot.** Interprets the ESC d command as even dot plot.
- **Double high.** Interprets the ESC d Command as double high. Select this option for backward compatibility.

Serial Matrix Character Set Menu

* = Factory Default

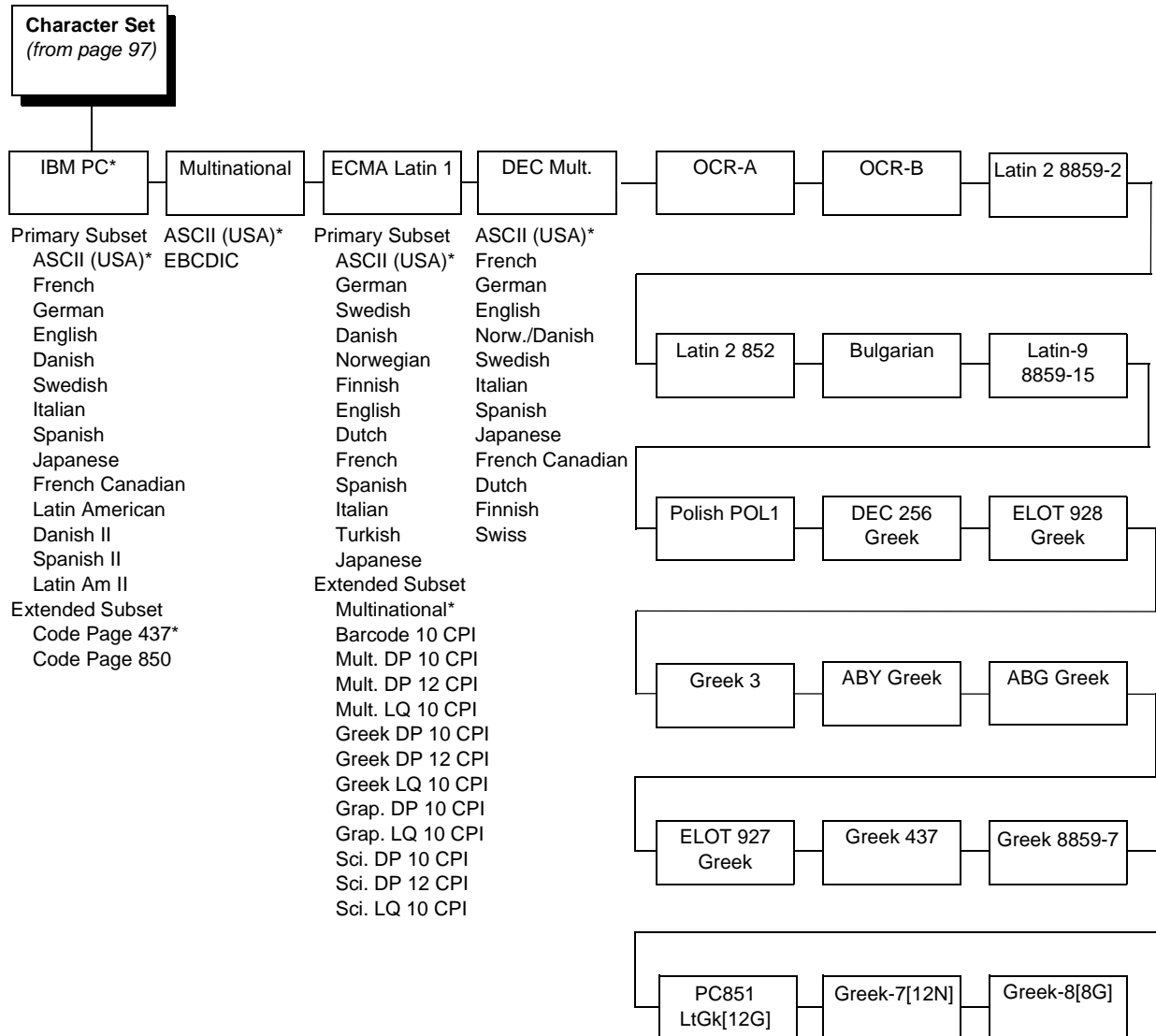

P-Series XQ Emulation

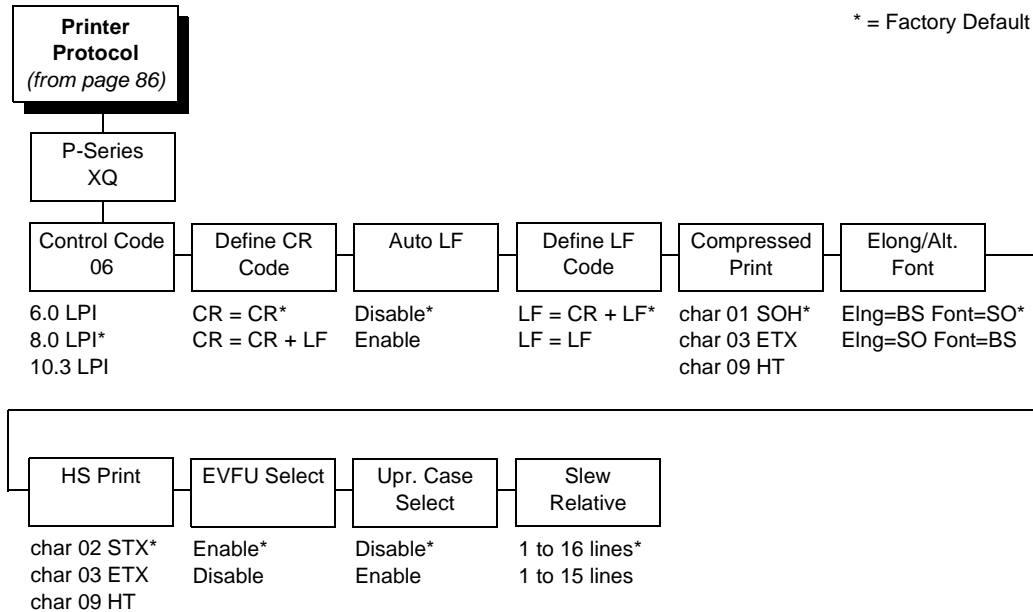

Control Code 06

Control Code 06 defines the function of ASCII code hex 06 (ACK). You can select an alternate line spacing of 6, 8, or 10.3 LPI.

Define CR Code

This option controls the action of the printer when it receives a Carriage Return code (hex 0D) from the host computer. If this feature is enabled, each time the printer receives a Carriage Return, it inserts an additional Line Feed code (hex 0A) into the data stream. Do not use this feature if the host computer sends Line Feeds to the printer.

- **CR = CR.** Does not insert an extra Line Feed after each Carriage Return.
- **CR = CR + LF.** Inserts an extra Line Feed after each Carriage Return. The next print position will be print position 1 of the next line.

Auto LF

This option defines the printer action when print data is received past the forms width setting.

- **Disable.** Discards any data past the forms width.
- **Enable.** Performs an automatic carriage return and line feed when data is received past the forms width.

Define LF Code

- **LF = CR + LF.** Forces an automatic carriage return with each line feed command received. The next print position is print position 1 of the next line.
- **LF = LF.** Does not perform an automatic carriage return when a line feed command is received. The next print position will be the current print position of the next line.

Compressed Print

Controls which host command sets compressed printing.

- CHAR 01 SOH
- CHAR 03 ETX
- CHAR 09 HT

Elong/Alt. Font

Controls which host command sets elongated (double high) fonts and extended character set.

- ELNG=BS (hex 08) FONT=SO (hex 0E)
- ELNG=SO FONT=BS

HS Print

Controls which host command sets high speed printing.

- CHAR 02 STX
- CHAR 03 ETX
- CHAR 09 HT

EVFU Select

Controls how the printer handles vertical formatting.

- **Enable.** Enables the VFU and selects P-Series compatible Electronic Vertical Format Unit (EVFU).
- **Disable.** Disables VFU processing.

Upr. Case Select

Controls how the printer handles lowercase characters it receives from the host computer. When enabled, all characters will be printed in uppercase.

- **Disable.** Prints lowercase characters received from the host computer as lowercase, and uppercase characters received from the computer as uppercase.
- **Enable.** Prints lowercase characters received from the host computer as their corresponding uppercase equivalents; uppercase characters received from the computer are printed as uppercase.

Slew Relative

“Slewing” is rapid vertical paper movement. This parameter determines the number of lines slewed (either 1-15 lines or 1-16 lines) when an EVFU Slew Relative command is received.

IGP/PGL Emulation

The IGP/PGL emulation can be configured either through the printer’s front panel or from the host computer with control codes. For a detailed description of configuration with control codes, see the *PGL Technical Reference Manual*. For information on configuring the emulation through the printer’s front panel, see the submenu below and the parameter descriptions that follow.

* = Factory Default

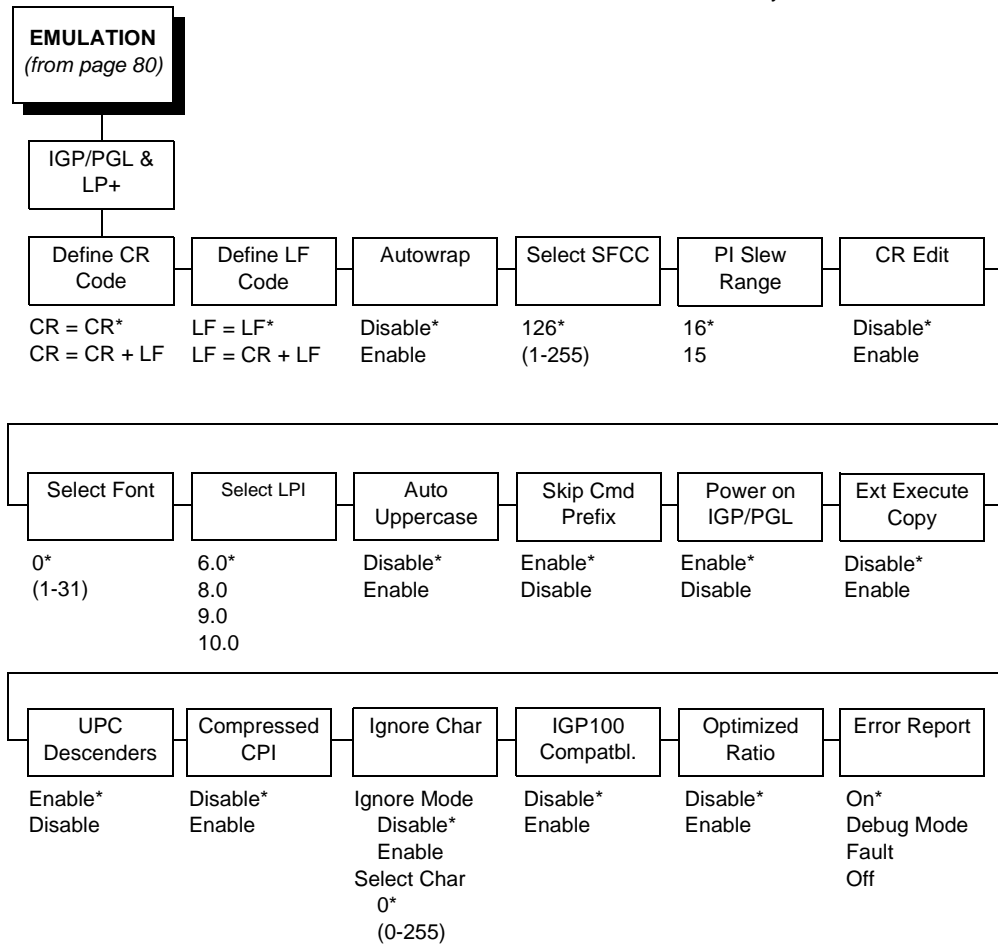

Define CR Code (Carriage Return)

This parameter forces the printer to insert an automatic Line Feed code into the data stream whenever a Carriage Return code occurs. This is to be used only if the host computer does not send Line Feeds to the printer.

- **CR = CR.** Does not perform a line feed. The next print position will be print position 1 of the current line.
- **CR = CR + LF.** Performs an automatic line feed. The next print position will be print position 1 of the next line.

Define LF Code (Line Feed)

This parameter forces the printer to insert an automatic Carriage Return code into the data stream whenever a Line Feed code occurs. This can be used in most installations, but it is required if the host computer does not send Carriage Returns to the printer.

- **LF = LF.** Does not perform an automatic carriage return. The next print position will be the current print position of the next line.
- **LF = CR + LF.** Performs an automatic carriage return. The next print position will be print position 1 of the next line.

Autowrap

This parameter determines if text will wrap to the next line when the line of text exceeds the right margin.

- **Disable.** Truncates the text beyond the right margin until a CR or CR + LF is received.
- **Enable.** Automatically inserts a CR + LF after a full print line.

Select SFCC

You can specify which decimal code (1-255) will be used as the Special Function Control Code (SFCC). The factory default setting is 126. The SFCC denotes that the following data is a PGL command.

PI Slew Range

You can specify how many lines the paper will feed.

- **16.** A paper slew of 0-15 will move 1-16 lines.
- **15.** A paper slew of 1-15 will move 1-15 lines. A paper slew of 0 will move 1 line.

CR Edit

This parameter determines if a carriage return will be followed by a line feed.

- **Disable.** The printer ignores all carriage returns that are not followed by line feeds.
- **Enable.** The printer processes all carriage returns, even for those that are not followed by line feeds.

Select Font

This parameter allows you to select a font for the IGP/PGL feature. The default is 0, which is U.S. ASCII. The following values are valid choices:

0	U.S. ASCII
1	German
2	Swedish
3	Danish
4	Norwegian
5	Finnish
6	English
7	Dutch
8	French
9	Spanish
10	Italian
11	Turkish

Values 12-23 are undefined and will default to 0. You can set values 24-31 to specific fonts; refer to the USET command in the *IGP/PGL Technical Reference Manual*.

Select LPI

This is the number of lines to be printed per inch. For example, at 6 lpi there is 1/6 inch from the top of one print line to the top of the next print line.

Auto Uppercase

This parameter enables the printer to print text in all uppercase when using the ALPHA command.

- **Disable.** The printer will print text in upper and lowercase.
- **Enable.** The printer will print text in uppercase only.

Skip Cmd Prefix

This parameter determines if the printer will print any data before a PGL command is received.

- **Enable.** The printer ignores all data on the current line before an IGP command.
- **Disable.** The printer will print all data on the current line before an IGP command.

Power on IGP/PGL

You can set the IGP feature so that it is enabled or disabled when the printer is powered on.

- **Enable.** The PGL is enabled when the printer is powered on. (The PGL feature is initialized in the Normal mode.)
- **Disable.** The PGL is disabled when the printer is powered on. (The PGL feature is initialized to the Quiet mode.)

Ext Execute Copy

- **Disable.** Dynamic data, overlay data, etc. are not allowed if the optional Form Count parameter (number of forms to print) is specified as part of the Execute command. (This setting is IGP-100 compatible.)
- **Enable.** Dynamic data, overlay data, etc. are allowed within a form in which the Form Count parameter is specified in the Execute command. In this case, the exact same form (with identical dynamic data) is printed for whatever the Form Count is. However, incremental data is not incremented since the page that is printing is exactly the same, the overlay data is only printed with the first form and not on subsequent forms, and each form is printed on a separate page.

UPC Descenders

This parameter allows you to print bar code descenders when human readable data is not presented in the UPC/EAN bar codes.

- **Enable.** UPC/EAN bar codes are printed with descenders, even if there is no human readable data.
- **Disable.** UPC/EAN bar codes are printed without descenders if there is no human readable data.

Compressed CPI

This parameter allows you to choose a compressed character (60% shorter) for 17 or 20 CPI instead of the normal height character.

- **Disable.** The PGL does not use compressed 17 or 20 CPI font.
- **Enable.** Uses the standard compressed 17 or 20 CPI font.

Ignore Char

Ignore Mode

This parameter instructs the PGL to ignore the character selected under the Select Character menu.

- **Disable.** The PGL does not ignore any characters.
- **Enable.** The PGL ignores the characters specified in the Select Character menu.

Select Character

Instructs the PGL which decimal character (0-255) to ignore from the host.

IGP100 Compatbl.

This option instructs the IGP/PGL to behave similarly to the IGP-100 with respect to certain commands. All new users with new applications should select the Disable option. Selecting this mode insures the printer will behave as described in this manual.

- **Disable.** The IGP does not emulate the IGP-100 mode.
- **Enable.** The IGP emulates the IGP-100 version.

Optimized Ratio

This option selects different bar code ratios for certain bar codes including Code 39 and Interleaved 2 of 5. It is included for compatibility with the IGP-X00 printers.

- **Disable.** Uses standard bar code ratios.
- **Enable.** Selects the alternate bar code ratios.

Error Report

Sets the error reporting capability for IGP/PGL forms.

- **On.** Full boundary error checking reported. Any element which falls off the current page is reported as an error.
- **Debug Mode.** The printer is put in debug mode whenever a form is defined in Create Form Mode. Each line of the Create Form is printed along with an error if one occurred. This is the same functionality as if there were a slash (/) entered before the Create Form Name.
- **Fault.** When an error occurs, the error is printed, and the message IGP/PGL ERROR appears on the printer front panel. The printer then stops printing and goes offline. The error must be cleared before the printer can resume normal operation.
- **Off.** No form boundary checking. Graphic elements appear clipped if they are beyond the page boundaries.

IGP/VGL (Code V) Emulation

The IGP/VGL (Code V) emulation can be configured either through the printer's front panel or from the host computer with control codes. For a detailed description of configuration with control codes, see the *QMS Code V Technical Reference Manual*. For information on configuring the emulation through the printer's front panel, see the submenu below and the parameter descriptions that follow.

* = Factory Default

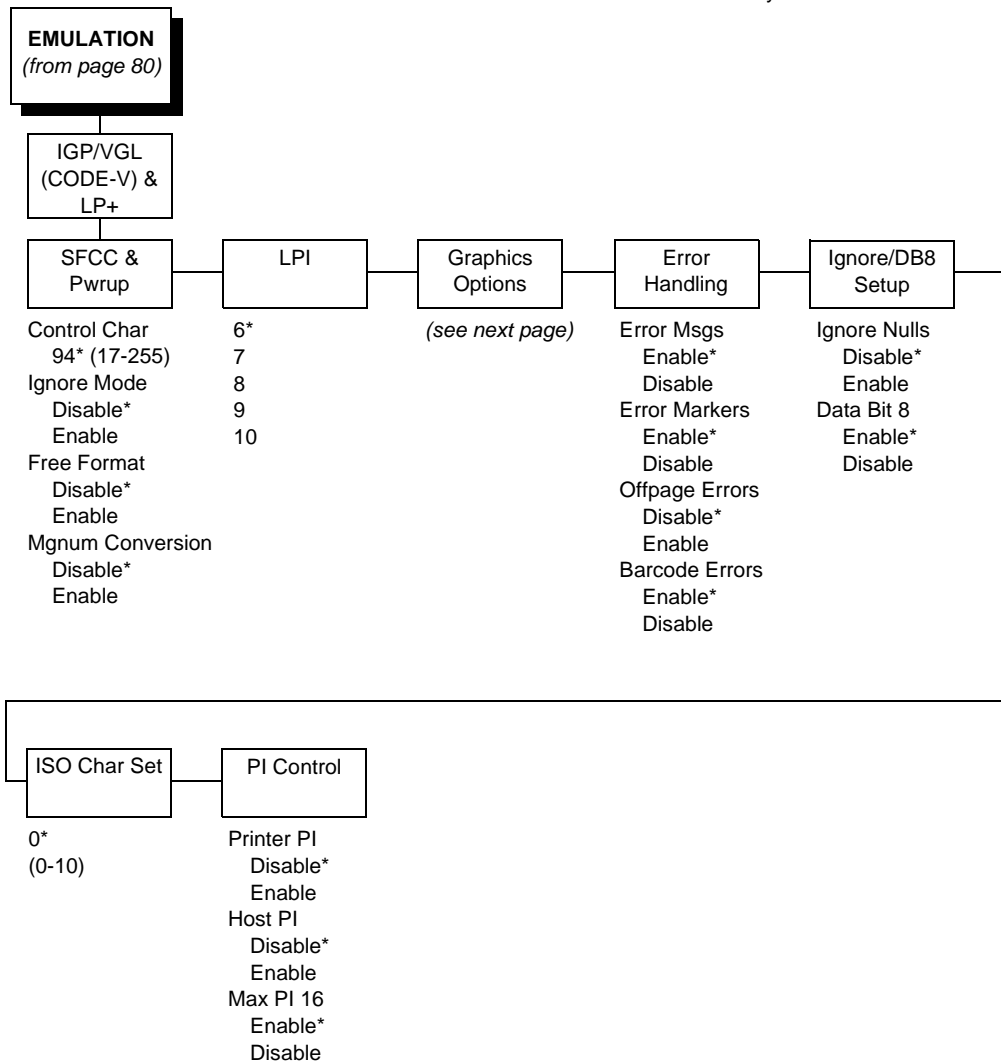

* = Factory Default

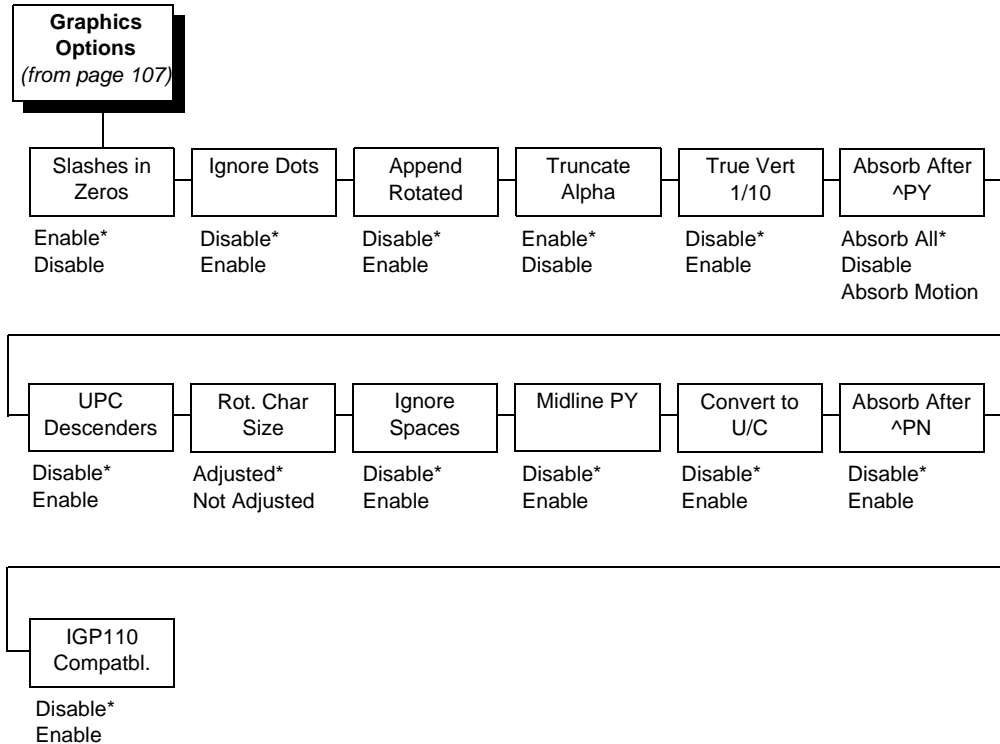

SFCC & Pwrap

This option has several suboptions which define the SFCC and power-up configuration used with Code V.

SFCC

This option selects the Special Function Control Code. The default value is the caret ^ (decimal 94). Valid values are 17 through 255. Throughout this section, the ^ is used as the SFCC. Run a configuration printout to determine the currently selected SFCC.

Ignore Mode

- **Disable.** The default.
- **Enable.** Selects the ignore mode as the power-up default, and selects the graphics mode ^PY as the power-up default. All characters are ignored until a ^A command is received.

Free Format

- **Disable.** The default.
- **Enable.** Selects free format mode as the power-up default, and selects the graphics mode ^PY as the power-up default. Free format causes the Code V to ignore carriage returns, line feeds, and all characters below hex 20 sent from the host.

Mgnum Conversion

- **Disable.** The default.
- **Enable.** Selects the graphics mode ^PY as the power-up default.

LPI

The number of lines to be printed per inch. For example, at 6 lpi there is 1/6 inch from the top of one print line to the top of the next print line.

Graphics Options

Following are several options which configure printing output:

Slashes in Zeros

This parameter allows you to print the numeral "0" with or without the slash. This option applies to all character sets except OCR-A and OCR-B.

- **Enable.** Zero is printed with a slash.
- **Disable.** Zero is printed without a slash.

Ignore Dots

- **Disable.** The default.
- **Enable.** Causes the Code V to expect position values to be specified in only 1/10ths of an inch. If the dot position is also given, it is treated as text.

Append Rotated

- **Disable.** Logos and alphanumeric strings are treated as separate elements.
- **Enable.** Appends logos to an alphanumeric string rotated in a clockwise, counterclockwise, or inverted orientation.

Truncate Alpha

When enabled, this parameter prevents the printing of Error 48 (Element Off Page Error) if alphanumeric data, including spaces, extends beyond the right side of the form.

True Vert 1/10

- **Disable.** A vertical 1/10 of an inch parameter is used as 7/72 of an inch. The absolute move is slightly smaller than expected. For example, a one inch move would be 70/72 of an inch. Vertical moves that have the same value will be identical in length.
- **Enable.** A vertical 1/10 of an inch parameter is used as 1/10 of an inch. Rounding occurs to the nearest 1/72 of an inch. This can cause vertical moves that have the same value to differ by $\pm 1/72$ of an inch.

Absorb after ^PY

- **Absorb Motion.** Prevents paper motion following a system terminator in a graphics ^PY command.
- **Absorb All.** The system ignores all the data and terminator until a host-generated terminator is detected.
- **Disable.** System terminators following a graphics command are sent to the printer and result in paper motion.

UPC Descenders

- **Disable.** UPC/EAN bar codes are printed without descenders if there is no human readable data.
- **Enable.** UPC/EAN bar codes are printed with descenders, even if there is no human readable data.

Rot. Char Size

- **Adjusted.** Rotated (clockwise/counterclockwise), expanded characters have a different size than an unrotated character with the same size parameters.
- **Not Adjusted.** Rotated, expanded characters will be the same size as unrotated characters with the same size parameters.

Ignore Spaces

- **Disable.** Trailing spaces are not deleted from alphanumeric elements in a graphics pass.
- **Enable.** Trailing spaces are deleted from alphanumeric elements in a graphics pass.

Midline PY (includes ^PN)

- **Disable.** The Graphics mode Enable command, ^PY, must be the first three characters of a line.
- **Enable.** The ^PY or ^PN can occur anywhere in a line.

Convert to U/C

- **Disable.** Lowercase characters are printed normally.
- **Enable.** All lowercase alphabetic characters are converted to uppercase.

Absorb After ^PN

- **Disable.** All line terminators that immediately follow the ^PN command are sent to the printer and processed.
- **Enable.** All line terminators that immediately follow the ^PN command are ignored.

IGP110 Compatbl.

This option instructs the Code V to behave similarly to the IGP-110 with respect to certain commands. All new users with new applications should select the Disable option. Selecting this mode insures the printer will behave as described in this manual.

- **Disable.** The IGP does not emulate the IGP-110 mode.
- **Enable.** The IGP emulates the IGP-110 version.

Error Handling

Following are several options which define how errors are reported:

Error Msgs

- **Enable.** Command syntax is checked and error messages printed when command parameters are incorrect.
- **Disable.** Error checking and error messages are suppressed.

Error Markers

- **Enable.** Prints the following error markers for those elements that print beyond the page boundaries:
 - >> for elements that begin off the right side of the page;
 - << for elements that begin at the indicated position but end off the page;
 - ◆ for elements where the starting position of the command contains an error other than an off-page error.

Offpage Errors

- **Disable.** Does not report errors for elements that start or end beyond the right edge of the page.
- **Enable.** Reports errors for elements that start or end beyond the right edge of the page.

Barcode Errors

- **Enable.** An error message will print when invalid bar code data is encountered.
- **Disable.** Code V will not print an error for illegal bar code data; the bar code will be skipped.



Note

When Barcode Errors is disabled, the Code V emulation will try to make the best use of invalid data by either truncating extra digits or adding zeros to the end of bar code data to meet minimum data length requirements for some bar codes. Not all errors will be corrected.

Ignore / DB8 Setup

Following are several options which define character filtering and data bit 8.

Ignore Nulls

- **Disable.** None of the null characters (hex 00 or 80) are ignored.
- **Enable.** Null characters are filtered out of the data stream.

Data Bit 8

- **Enable.** The PI line is not passed directly from host to printer; all 8 bits are used for data bits, and characters in the hex 80-FF range can be accessed.
- **Disable.** When the host PI line is enabled, data bit 8 internally indicates PI line status. To use the PI line, disable data bit 8 and enable the Host PI configuration option (under the PI Control option, below).



Note

Data bit 8 is interpreted as either data bit 8 or the PI signal, but never both. When enabled as data bit 8, data bit 8 has priority over the PI signal, and all data above hex 7F is used to access character data and not to interpret PI line data.

Conversely, when data bit 8 is disabled and the PI signal is used, data bit 8 of the data is reserved for use as the PI function, and you cannot access characters in the hex 80-FF range. Therefore, to access characters in the hex 80-FF range, data bit 8 must be enabled.

ISO Char Set

This parameter allows you to select a font for the IGP/VGL (Code V) feature. The default is 0, which is U.S. ASCII. The following values are valid choices:

0	U.S. ASCII
1	United Kingdom
2	Swedish/Finnish
3	Norwegian/Danish
4	Japanese
5	German
6	French
7	Italian
8	Spanish
9	PC Subset
10	Code V Version I

PI Control

Printer PI

- **Disable.** The ASCII emulation is configured with the PI line disabled.
- **Enable.** The ASCII emulation is configured with the PI line enabled.

Host PI

- **Disable.** The host does not send PI signals.
- **Enable.** The host sends PI signals. The Data Bit 8 configuration option must be disabled to transmit the PI line to the printer.

Max PI 16

- **Enable.** A paper slew of 0-15 will move 1-16 lines.
- **Disable.** A paper slew of 1-15 will move 1-15 lines. A paper slew of 0 will always move 1 line.

Maint/Misc Menu

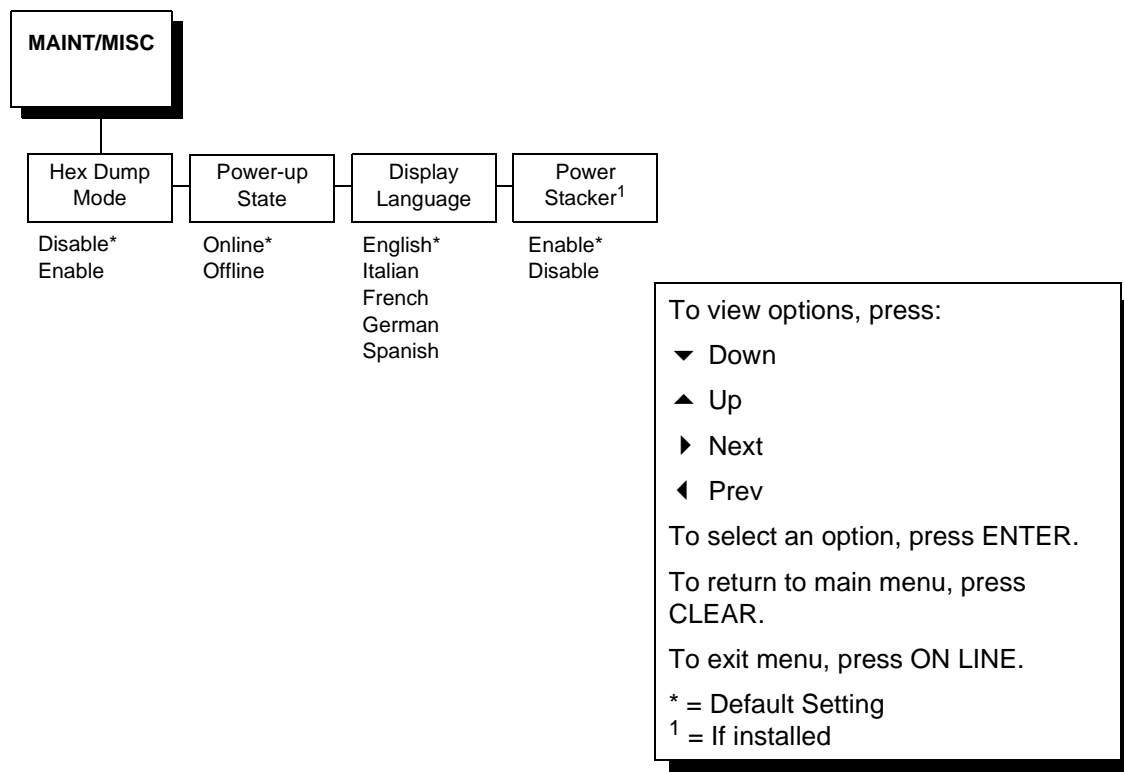

Hex Dump Mode

A hex code printout (or hex dump) translates all incoming data to hexadecimal equivalents. A hex dump lists each ASCII data character received from the host computer together with its corresponding two-digit hexadecimal code. Hex dumps can be used to troubleshoot some types of printer data reception problems. Figure 23 on page 280 shows a hex dump sample.

Power-up State

This parameter allows you to configure the printer to power-up in the offline or online state. Online is the default.

Display Language

This parameter chooses the language that will appear on the message display: English, Italian, French, German, or Spanish.

Power Stacker

This parameter, which is only presented with the 1500QS model, allows you to enable (the default) or disable power stacker operation.

Note



When running short print jobs with the power stacker enabled, it automatically moves to the top position.

Note



When you press the Online button, the stacker automatically moves down one inch. When you press the Offline button, the stacker moves up approximately one inch. When printing a batch file, the user must press the stacker down until the lower limit is reached.

Host Interface Menu

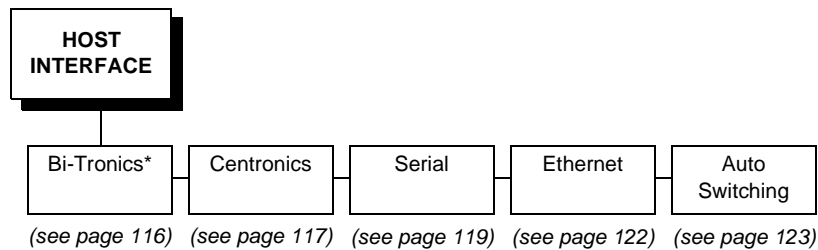

The Host Interface Menu Diagram enables you to select and configure an interface between the printer and your host computer:

- Bi-Tronics (factory default)
- Serial
- Centronics
- Ethernet
- Auto Switching

Note

The printer will not work online unless the type of interface selected from the HOST INTERFACE menu matches the type of interface in your host computer. The interface in your host computer is the one that connects to the data cable of the printer. For example, if the interface in your computer is a serial interface, then the serial interface must be selected from the HOST INTERFACE menu in the printer.

The currently selected interface is indicated with an asterisk on the control panel message display. Each interface has its own submenu with the set of associated interface parameters that you may configure. The host interface and its associated parameters control the interface between the printer and your host computer. Descriptions follow for each of the host interface submenus.

Bi-Tronics Submenu

Note

The Bi-Tronics parameters in the printer must be set the same as the interface in the host computer (at the other end of the data cable of the printer). Otherwise, the printer might not work online, and data characters from the computer might not print or might print as “garbled” text.

* = Factory Default

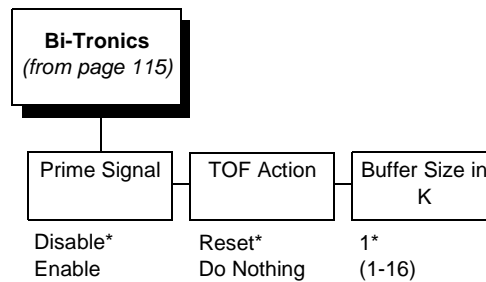

Prime Signal

- **Disable.** The parallel port does not perform a warm start (reboot) if the host asserts the prime signal.
- **Enable.** The parallel port performs a warm start (reboot) if the host asserts the prime signal.

TOF Action

- **Reset.** A form feed is performed before a warm start when the prime signal is asserted from the host. This setting is used only if the Prime Signal parameter is enabled.
- **Do Nothing.** No form feed is performed on reset.

Buffer Size in K

This option configures the amount of memory allocated for the Bi-Tronics port buffer. You can designate the size of the printer buffer from 1 through 16 Kbytes.

Centronics (Parallel) Submenu



The Centronics parameters in the printer must be set the same as the interface in the host computer (at the other end of the data cable of the printer). Otherwise, the printer might not work online, and data characters from the computer might not print or might print as "garbled" text.

* = Factory Default

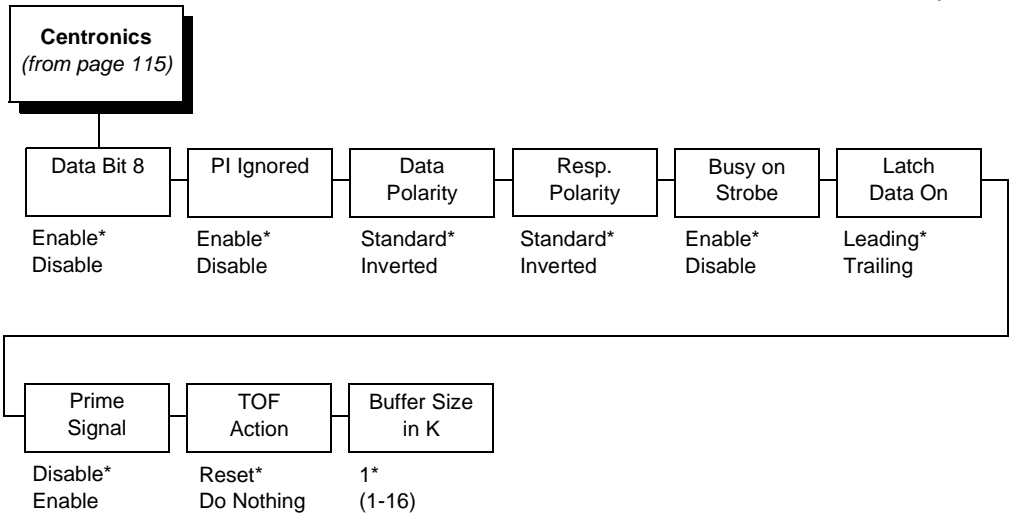

The Centronics submenu provides the options and settings available to configure the interface as required for your application. These options and available settings are outlined in the following paragraphs.

Data Bit 8

- **Enable.** Allows access to the extended ASCII character set.
- **Disable.** The printer interprets bit 8 of each incoming data character as a zero, regardless of its actual setting.

PI Ignored

The PI (Paper Instruction) signal is used to control vertical paper motion.

- **Enable.** Ignores the PI signal and treats the data as characters or control codes.
- **Disable.** Causes the printer to interpret the eight data lines as VFU commands when the PI signal is true.

Data Polarity

The Data Polarity parameter must be set to match the data polarity of your host computer.

- **Standard.** Does not expect the host computer to invert the data.
- **Inverted.** Expects the data received on the data lines from the host computer to be inverted. Ones become zeros, and vice-versa.

Resp. Polarity

The Response Polarity parameter must be set to match the response polarity of your host computer. This option sets the polarity of the Acknowledge, Online, Fault, Paper Empty, and Busy signals.

- **Standard.** Does not invert the response signals.
- **Inverted.** Inverts the response signals sent to the host computer.

Busy on Strobe

- **Enable.** Asserts a busy signal after each character is received.
- **Disable.** Asserts a busy signal only when the print buffers are full.

Latch Data On

The Latch Data On parameter specifies whether the data is read on the leading or trailing edge of the data strobe signal.

Prime Signal

- **Disable.** The parallel port does not perform a warm start (reboot) if the host asserts the prime signal.
- **Enable.** The parallel port performs a warm start (reboot) if the host asserts the prime signal.

TOF Action

- **Reset.** A form feed is performed before a warm start when the prime signal is asserted from the host. This setting is used only if the Prime Signal parameter is enabled.
- **Do Nothing.** No form feed is performed on reset.

Buffer Size in K

Configures the amount of memory allocated for the Centronics parallel port buffer. The default is 1 Kbyte, but you can specify between 1 and 16 Kbytes, in 1-Kbyte increments.

Serial Submenu

Note



The serial parameters in the printer must be set the same as the interface in the host computer (at the other end of the data cable of the printer). Otherwise, the printer might not work online, and data characters from the computer might not print or might print as "garbled" text.

* = Factory Default

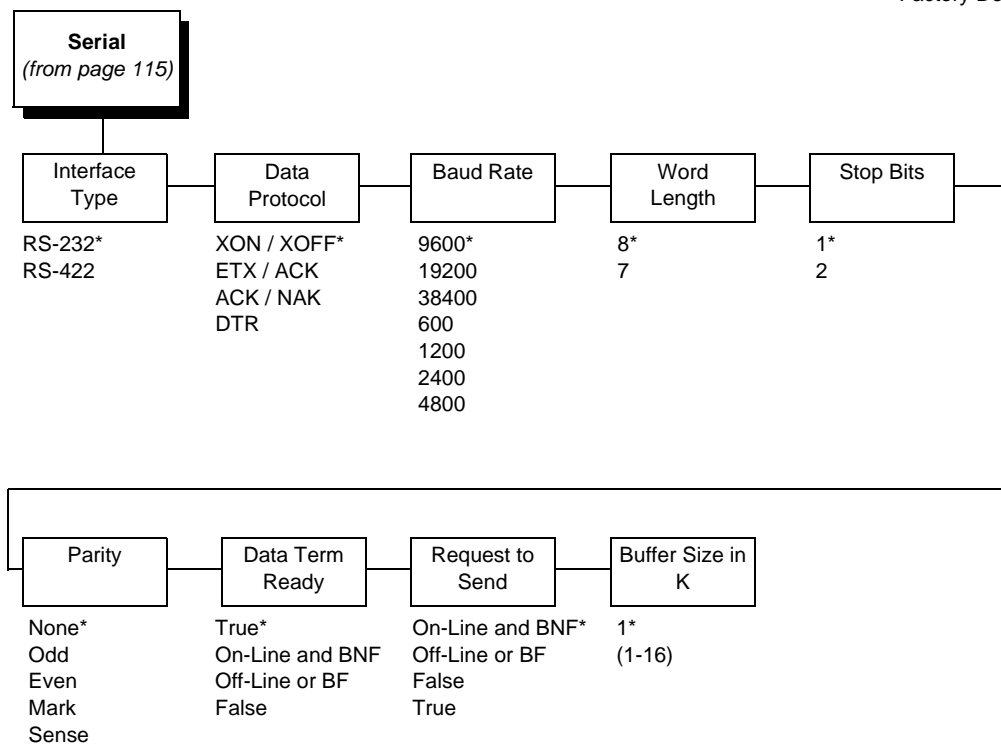

The serial submenu allows you to choose the configuration of the Serial host interface type, as shown above. Several other serial parameters are included on this menu, as described below.

Interface Type

Allows you to select either the RS-232 (the default) or RS-422 serial port interface.

Data Protocol

You can select one of the following serial interface protocols to meet the host interface requirements.

- **XON / XOFF.** The default. The printer controls the flow of communication from the host by turning the transmission on and off.

In some situations, such as when the buffer is full or the timing of signals is too slow or too fast, the printer will tell the host to stop transmission by sending an XOFF character.

An XOFF character is sent when the number of empty bytes in the buffer is less than or equal to 25 percent of the buffer size.

If the host keeps sending data after an XOFF is sent, the printer firmware will continue to send an XOFF for every 16 characters received.

When cleared, the printer will resume receiving data (XON). The data does not have any End of Text codes; XON / XOFF is a non-block protocol.

- **ETX / ACK.** End of Text / Acknowledge. The host controls the flow of communication to the printer by sending a block of data and ending the block with an End of Text (ETX) signal. When the printer receives the ETX signal, it will acknowledge the ETX, thereby acknowledging it has received the entire block of data.
- **ACK / NAK.** ACK means acknowledge; the device acknowledges it has accepted a transmission. NAK means a negative acknowledge; the device did not receive the transmission.
- **DTR.** Data Terminal Ready. The printer controls the data flow by sending this hardware signal to the host. If there is enough room in the printer buffer, the printer will send a high signal. If the buffer is full, the printer will send a low signal. DTR tells the host if it is safe to send more data. If the host sends data during an unsafe condition, data will be lost.

Baud Rate

Sets the baud rate of the serial interface in the printer. Baud rate is the speed at which serial data is transferred between the host computer and the printer. The choices for the RS-232 and RS-422 interfaces are 600, 1200, 2400, 4800, 9600, 19200, and 38400. The default is 9600 baud.

Note

If you select a baud rate that is 19200 or greater, you may need to increase the Buffer Size in K parameter from the default (1 Kbyte) to improve performance.

Word Length

Sets the length of the serial data word. The length of the data word can be set to 7 or 8 bits, and must match the corresponding data bits setting in the host computer. The default is 8 bits.

Stop Bits

Sets the number of stop bits in the serial data word. Either one or two stop bits can be selected. The setting must match the corresponding stop bit setting in the host computer. The default is 1 bit.

Parity

Set for odd parity, even parity, mark, sense, or no parity. The setting must match the corresponding parity setting in the host computer. The default is None.

Data Term Ready

This configuration is part of hardware flow control and determines when the Data Terminal Ready (DTR) signal is generated. This signal indicates whether or not the printer is ready to receive data.

- **True.** Continuously asserts the DTR signal (the default).
- **On-Line and BNF (buffer not full).** Asserts the DTR signal when the printer is online and the internal serial buffer is not full.
- **Off-Line or BF (buffer full).** Asserts the DTR signal when the printer is offline or the internal serial buffer is full.
- **False.** Never asserts the DTR signal.

Request to Send

This configuration is part of hardware flow control and determines when the Request to Send (RTS) signal is generated. This signal indicates whether or not the printer is ready to receive data.

- **On-Line and BNF.** Asserts the RTS signal when the printer is online and the internal serial buffer is not full (the default).
- **Off-Line or BF.** Asserts the RTS signal when the printer is offline or the internal serial buffer is full.
- **False.** Never asserts the RTS signal.
- **True.** Continuously asserts the RTS signal.

Buffer Size in K

Configures the amount of memory allocated for the serial port buffer. The default is 1 Kbyte, but you may specify between 1 and 16 Kbytes, in 1-Kbyte increments.

Ethernet Submenu

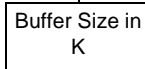
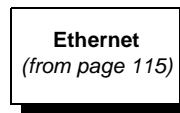

16*
(1-16)

* = Factory Default

The Ethernet interface allows you to locate the printer on a LAN rather than attach the host directly into the printer.

Buffer Size in K

This option configures the amount of memory allocated for the Ethernet buffer. The default is 16 Kbytes. You can specify between 1 and 16 Kbytes, in 1-Kbyte increments.

Auto Switching Submenu

* = Factory Default

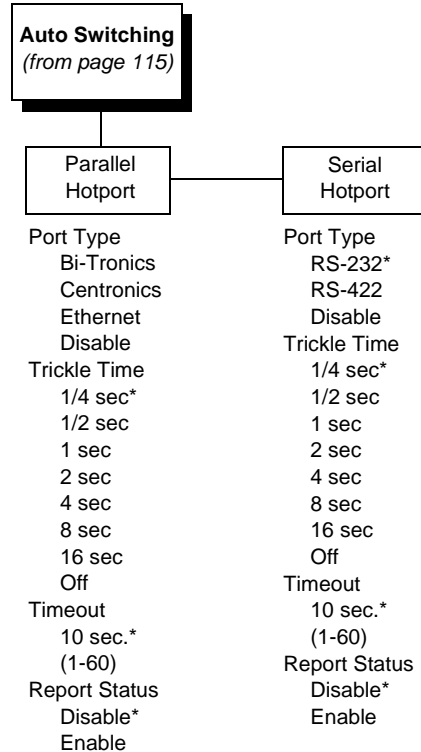

Auto Switching

Gives the printer the ability to handle multiple data streams sequentially. With Auto Switching, the printer can service hosts attached to the serial and parallel ports as if they were the only interface connected.

For example, if the host computer sends one print job to the RS-232 serial port and a separate print job to the Bi-Tronics parallel port, the printer's Auto Switching is able to handle both jobs, in the order they were received, without the user having to reconfigure the selected interface between jobs.

Port Type

Allows you to select the types of parallel and/or serial interfaces which are connected to the printer. For example, if your printer is attached to one host with a Centronics connection and a second host with an RS-422 serial connection, you would select Centronics under the Parallel Hotport menu and RS-422 under the Serial Hotport menu.

Trickle Time

When the printer is printing data from a host and a second job is received by the printer from a different host, Trickle Time prevents the second host from timing out while it is waiting for its data to be printed. In order to support this feature, the port has to be able to accept data from the host and store it for future use.

For example, if the printer is printing a job from the serial port and then receives a second print job from the parallel port, the data from the parallel port will “trickle” bit by bit into the printer buffer to prevent a timeout error from being sent back to the host connected to the parallel port.

The selected value is the time that the printer waits before getting the next byte of data from the host. The Trickle Time value should be less than the host time out value, but not too much shorter or else the printer fills up its buffer too fast.

Timeout

This is the value used by the printer to time out from the current port and check the other selected Port Types for data to print. When the printer has not received data from the host after a certain period of time, it needs to Timeout in order to service the other ports.

Report Status

- **Disable.** When a fault occurs on the printer, only the active port reports the fault to the host.
- **Enable.** The port will report any fault even when it is not the current active port.

Ethernet Params Menu

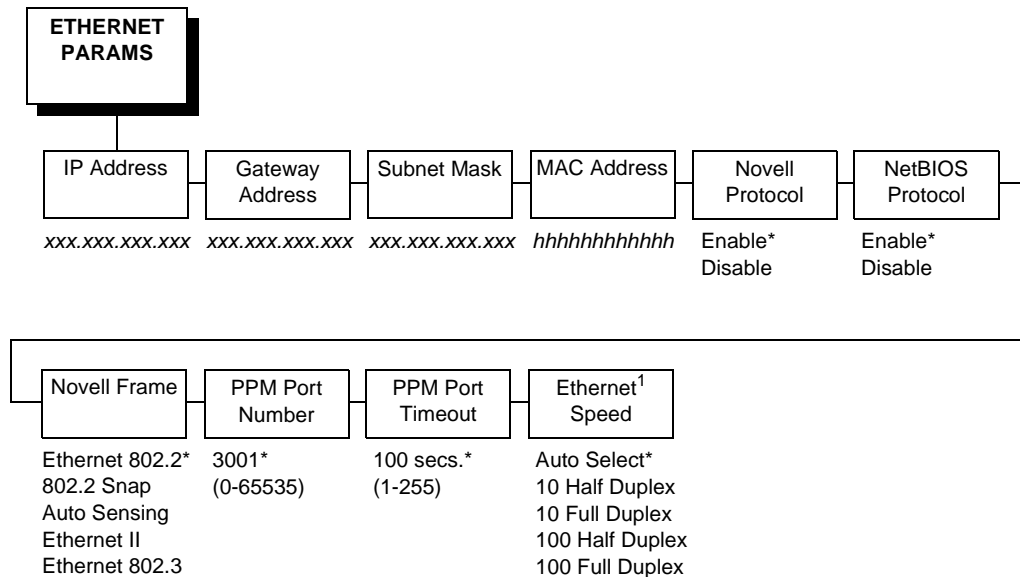

* Factory Default

¹ If you change the Ethernet speed setting, you must also change the switch or hub setting to match.

The ETHERNET PARAMS menu helps your printer communicate on a network.

For information on assigning the IP Address, Gateway Address, Subnet Mask, and MAC Address, refer to **Μεθοδος Οφ Αδφυστινγ Παπερ Ποσιτιον© ον παγε 170**.

You may also enable or disable the Novell or NetBIOS Protocols within this menu, as well as selecting which Novell Frame scheme is used in processing Novell signals. See Chapter 11, "Novell Configuration" for more details.

If the printer is connected to the Remote Management Software (RMS), the RMS Port number and PPM Port Timeout settings must match the settings in the Remote Management Software program.

IP Address

A numeric address such as 123.45.61.23 which identifies a printer or server in a LAN or WAN.

Gateway Address

A gateway address is the IP address of a hardware device (gateway) that translates data between two incompatible networks, which can include protocol translation.

Subnet Mask

A binary value used to divide IP networks into smaller subnetworks or subnets. This mask is used to help determine whether IP packets need to be forwarded to other subnets.

MAC Address

This menu item is the Manufacturer's Assigned Number, and is unique for each printer. It is read-only.

Novell Protocol

This option determines whether the Novell protocol will be available. The selections are as indicated below:

- **Enable.** (the default) makes the Novell protocol available with the ethernet installed.
- **Disable.** Makes the Novell protocol unavailable during printer operation.

NetBIOS Protocol

This option determines whether the NetBIOS protocol will be available. The selections are as indicated below:

- **Enable.** (the default) makes the NetBIOS protocol available with the ethernet installed.
- **Disable.** Makes the NetBIOS protocol unavailable during printer operation.

Novell Frame

This selection determines which framing scheme will be used in processing Novell signals.

- Auto Sensing (the default)
- Ethernet II
- Ethernet 802.3
- Ethernet 802.2
- 802.2 Snap

Ethernet Speed

This menu option only appears if a 10/100Base-T network interface card (NIC) is installed. The Ethernet Speed menu allows compatibility with different systems and networks. The factory default is Auto Select.

- **Auto Select.** (the default) This setting tells the 10/100Base-T NIC to perform an auto detection scheme and configure itself to be 10 Half Duplex, 10 Full Duplex, 100 Half Duplex, or 100 Full Duplex.
- **10 Half Duplex.** Tells the 10/100Base-T NIC to communicate at 10 Megabits per second using half duplex.
- **10 Full Duplex.** Tells the 10/100Base-T NIC to communicate at 10 Megabits per second using full duplex.
- **100 Half Duplex.** Tells the 10/100Base-T NIC to communicate at 100 Megabits per second using half duplex.
- **100 Full Duplex.** Tells the 10/100Base-T NIC to communicate at 100 Megabits per second using full duplex.

Printer Control Menu

The Printer Control Menu allows you to choose the printer's behavior. Options on this menu, as shown below, are described in the following pages.

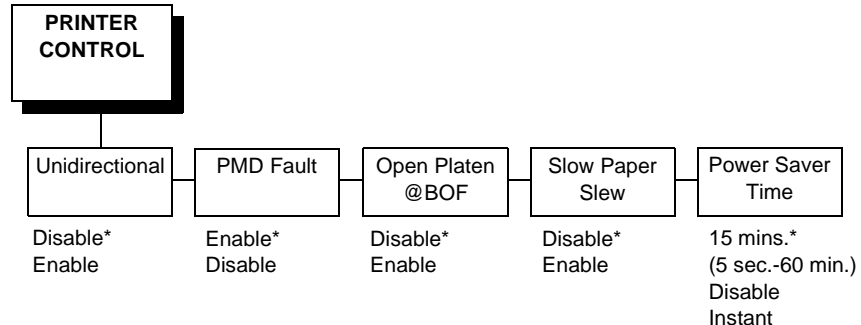

To view options, press:

- ▼ Down
- ▲ Up
- ▶ Next
- ◀ Prev

To select an option, press ENTER.

To return to main menu, press CLEAR.

To exit menu, press ON LINE.

* = Default Setting

Unidirectional

The Unidirectional feature affects both print quality and printing speed. By setting this feature, you can configure the printer to print in both directions of the shuttle sweep (bidirectional), or to print in one direction only (unidirectional).

You might want to enable this feature when printing bar codes, high quality text and graphics, or other printing that requires precise vertical alignment.

Although enabling this feature reduces print speed, it enhances the vertical alignment of dots and produces cleaner, sharper bar codes and text. Choices include the following:

- **Disable.** The default. The printer will print all data in both directions of the shuttle sweep (bidirectional printing). This choice produces higher printing speed.
- **Enable.** The printer will print all data in only one direction of the shuttle sweep (unidirectional printing). This choice produces higher print quality.

PMD (Paper Motion Detection) Fault

- **Enable.** If a paper jam occurs, an audible alarm beeps, the LCD displays the message, "CLEAR PAPER JAM," and the printer stops printing.
- **Disable.** You should disable PMD only if special paper requires it.

Caution

Once PMD is disabled, paper motion is not monitored. If a paper jam occurs, the printer ignores the condition and continues to print, which can cause severe damage to the printer.

Open Platen @ BOF (Bottom of Form)

Some special forms have perforation areas that are too thick to pass through the print station. This parameter, when enabled, opens and closes the platen when the perforations move across the platen. When enabling this parameter, you must set the forms length to match the physical distance between perforations.

Slow Paper Slew

This parameter affects the speed at which paper advances into the stacking area of the printer. The speed may be slowed down by enabling this feature.

- **Disable.** The default. The printer will slew and stack paper at maximum speed.
- **Enable.** Causes the paper to stack at a slower pace. This ensures that certain forms will stack more neatly.

Power Saver Time

Power Saver is also referred to as the ENERGY STAR® Office Equipment Program. The Power Saver feature places the printer in “sleep mode” when the printer has not been used for a specified number of minutes. In sleep mode the printer is in low-energy idle state, all fans and higher voltages are off, and only +5Vdc logical circuits are active.

You can designate the number of minutes after which the printer will go into sleep mode. The range of time is from 0 to 60 minutes. The default is 15 minutes.

Pressing any key on the control panel or sending a print job to the printer will turn off sleep mode.

Diagnostics Menu

The diagnostics menu allows you to choose the diagnostics tests to be run and provides you with important system information. Options on this menu, as shown below, are described in the following pages.

¹If Ethernet adapter is present

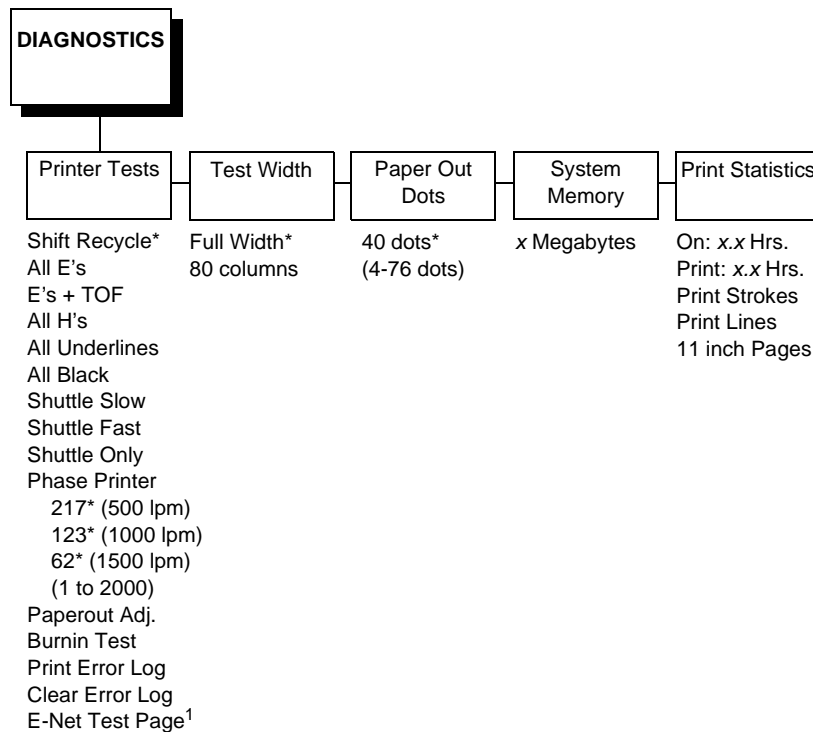

Printer Tests

The printer tests are used to check the print quality and printer operation.

Note

Your Customer Service Engineer typically runs these tests. They are described in more detail in the *P5000LJ Series Printers Maintenance Manual*.

The Printer Tests parameters are described below. (For test running procedures, see page 278.)

- **Shift Recycle.** A sliding alphanumeric pattern that identifies missing or malformed characters, improper vertical alignment, or vertical compression.
- **All E's.** A pattern of all uppercase E's that identifies missing characters, misplaced dots, smeared characters, improper phasing problems, or light/dark character variations.
- **E's + TOF.** A pattern of all E's followed by a form feed to the next page top of form, that identifies paper motion or feeding problems.
- **All H's.** A pattern of all uppercase H's used to detect missing characters, misplaced dots, smeared characters, or improper phasing.
- **All Underlines.** An underline pattern useful for identifying hammer bank misalignment.
- **All Black.** A condition where all dot positions are printed, creating a solid black band.
- **Shuttle Slow.** Verifies proper operation by exercising shuttle and ribbon motion at low speed.
- **Shuttle Fast.** Verifies proper operation by exercising shuttle and ribbon motion at fast speed.
- **Shuttle Only.** Exercises only the shuttle at fast speed.
- **Phase Printer.** It is recommended that only an authorized Printronix representative runs this test.

The Phase Printer test checks for wavy print. The initial phase value is set in the factory. The Customer Service Engineer (CSE) runs the test and checks the quality. (The phase value prints on the left margin.) If the print looks too wavy, the CSE changes the Phase Value parameter by pressing the ▼ key while the test is running. A value between 1 and 2000 displays. To change the value, the CSE presses the ► or ◀ key until the desired value displays, and then presses ENTER.

Note

The printer must be printing the phase pattern of “H’s” when the Phasing Value is changed or the new phasing value will not be written into non-volatile RAM (NVRAM). If the value is changed when not printing, the printer will return to its default phasing value when powered off and then back on.

- **Paperout Adj.** It is recommended that only a Hewlett-Packard Customer Service Engineer run this test.

The Paperout Adj. allows the Customer Service Engineer to specify where the last line of text will print when there is a paper out condition. Setting this parameter correctly prevents printing on the platen. (See the *P5000LJ Series Printers Maintenance Manual* for more information.)

- **Burnin Test.** Running this test is not recommended.
- **Print Error Log.** Prints a log of the last 50 errors that have occurred in the printer.
- **Clear Error Log.** Clears the error log.
- **E-Net Test Page.** Prints the Ethernet statistics stored on the Ethernet adapter (if present).

Test Width

This parameter permits you to run the self-tests at full width or 80 columns.

Caution

This parameter must match paper width used. If full width is selected for use with 80-column or 8.5-inch wide paper, damage to the hammer tips and platen may result.

Paper Out Dots

It is recommended that only an authorized Printronix representative sets this parameter.

Paper Out Dots allows the Customer Service Engineer to specify where the last line on the page will print when there is a paper out condition. Setting this parameter correctly prevents printing on the platen.

System Memory

This parameter displays the amount of RAM installed.

Print Statistics

You can view various printer statistics, such as hours of usage, and refer to these figures for preventive maintenance purposes. Printer statistics accumulate continuously; they do not reset when you turn off the printer.

All of the printer statistics are set to zero at the factory after burn-in testing.

- **On.** The cumulative time in hours the printer has been powered on. The range is from 0 to 30,000 hours.
- **Print.** The cumulative time in hours the printer has actually been printing. The range is from 0 to 30,000 hours.
- **Print Strokes.** The cumulative number of back-and-forth shuttle strokes the printer has printed during normal operation. The range is from 0 to 2,147,483,648 shuttle strokes.
- **Print Lines.** The cumulative number of lines the printer has printed. The range is from 0 to 2,147,483,648 print lines.
- **11 inch Pages.** The cumulative number of pages the printer has printed. The range in print pages is from 0 to 2,147,483,648 total inches of paper movement divided by 11.

RibbonMinder

RibbonMinder is a user-definable software feature which notifies the user when a ribbon should be changed. It does this by monitoring ink consumption and alerts you when the print quality falls below a level you designate. This is especially important if you are printing bar codes to be scanned.

```
ON LINE    100%
<printer emulation>
```

As printing continues, the percentage of usable ink in the ribbon decreases.

```
ON LINE    74%
<printer emulation>
```

Ribbon ink being consumed

```
ON LINE    8%
<printer emulation>
```

Ribbon life approaching end

When 0% usable ink appears, the printer is typically configured to stop printing and display the following message:

```
RIBBON INK OUT
CHANGE RIBBON
```

Note



Once you have set up options for RibbonMinder, it works without attention. When you begin printing with RibbonMinder enabled, the message display shows a ribbon life value of 100%. The ribbon life decreases as the ink is consumed.

RibbonMinder Menu

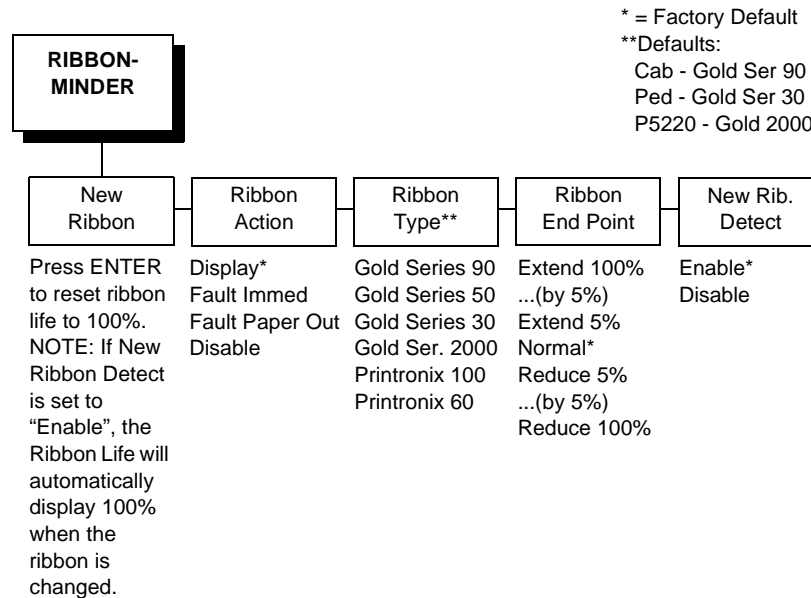

New Ribbon

This provides a means to manually set the printer when a new ribbon has been installed. The ribbon life displayed on the control panel (if active) is set to 100%. The count internal to the printer will also be reset, and the tabulation towards end of ribbon life will begin.

Ribbon Action

- Display.** The factory default for this setting is the DISPLAY mode. When DISPLAY is selected, the ribbon ink consumption will continually display on the control panel, decrementing as ink is consumed. When the ribbon life reaches 0%, the message RIBBON INK OUT / CHANGE RIBBON displays on the control panel. The printer will continue to accept new print jobs. No other indication (no flashing light, or warning beep) is given. The display can be cleared by replacing the ribbon when NEW RIBBON DETECT is enabled.

- **Fault immed.** When FAULT IMMED. mode is selected, and the ribbon life reaches 0%, the message RIBBON INK OUT/ CHANGE RIBBON displays on the control panel. The printer stops and goes into fault condition. To complete the job in progress, the user must press the CLEAR key. This allows the printer to continue printing for approximately two minutes. After two minutes, the printer goes into fault mode again, the RIBBON INK OUT/ CHANGE RIBBON display appears, and the printer status indicator flashes. Clear the display by (1) replacing the ribbon when NEW RIBBON DETECT is enabled, or (2) pressing the CLEAR key on the control panel. If the CLEAR key is pressed, the message will re-appear after approximately two minutes.
- **Fault paper out.** When FAULT PAPER OUT mode is selected, and the ribbon life reaches 5%, the printer continues to accept new print jobs until the printer runs out of paper. When an END OF FORMS/LOAD FORMS condition is cleared (paper is loaded), then the RIBBON INK LOW/ CHANGE RIBBON message appears and the printer status indicator flashes. The printer will not accept new print jobs until the ribbon is changed and the Ribbon Minder is reset to 100%.

In this mode, the Ribbon Minder is automatically reset when a “clean hands” ribbon is installed and NEW RIBBON DETECT is enabled. If another type of ribbon is used, the User must reset the Ribbon Minder using the New Ribbon menu selection.

- **Disable.** When DISABLE mode is selected, the ribbon life display is removed from the control panel, but the Ribbon Minder continues to monitor ink consumption. No indication (no flashing light, or warning beep) is given, and the printer continues to accept new print jobs indefinitely.

NOTE: When the printer displays “Ribbon Ink Out / Change Ribbon, “ disabling the ribbon action will not clear the message.

Ribbon Type

The factory default setting is dependent on the host printer. Printronix Gold Series 90 corresponds to the Cabinet version, Printronix Gold Series 60 for the Pedestal and Printronix Gold Series 2000 for the P5220. The relative length equivalents for each of the ribbon settings are:

Table 12. Length Equivalent Ribbon Settings

Ribbon Type (Char)	Equivalent Length	Actual Length
Gold Series 90 (90 million characters)	80 yards	90 yards
Gold Series 50 (50 million characters)	100 yards	55 yards
Gold Series 30 (30 million characters)	60 yards	40 yards
Gold Series 2000 (60 million characters)	100 yards	80 yards
Printronix 100 (50 million characters)	100 yards	100 yards
Printronix 60 (30 million characters)	60 yards	60 yards

Ribbon End Point

The factory default is NORMAL. This value corresponds to the character life expectancy of the installed ribbon. For example, the life of the Gold Series 90 ribbon is specified at 90 million characters. By selecting NORMAL Ribbon End Point, the Ribbon Minder will track characters up to 90 million before declaring RIBBON INK OUT / CHANGE RIBBON.

By changing this setting, the user can specify a point lower or higher at which the RIBBON INK OUT / CHANGE RIBBON message is displayed. Using the example above, if the Ribbon End Point is set to Reduce 50%, the RIBBON INK OUT / CHANGE RIBBON message would display at 45 million characters. If Ribbon End Point was set to Extend 50%, the message would display at 135 million characters. In this way, the user can set ribbon life to match the required print density for the application.

NOTE: The percentage of ribbon use displayed on the control panel by the Ribbon Minder Ink Consumption display tracks the consumption based on the adjusted Ribbon End Point. For example, if the Ribbon End Point is set to Reduce 50% (45 million characters for the Gold Series 90 ribbon), the Ribbon Minder Ink Consumption display will start at 100%, and decrement to reach 0% as 45 million characters are printed.

If the Ribbon Type is changed from the factory default to another value, Ribbon Usage will adjust accordingly, where 100% corresponds to the proportionate value of the selected type. For example, if the Ribbon Type is set to Printronix 60 (approximately 30 million), Ribbon End Point set to NORMAL would correspond to 30 million characters. With this same 60 yard ribbon, if Ribbon End Point was set to Reduce 50%, the character count would be set to 15 million, etc. Ribbon Minder will track the ink consumption based on these new parameters, display 100% when a new ribbon is installed and tracking usage to 0%.

NOTE: Ribbon Ink Consumption is determined not by actual character count, but by an accumulation of a specified number of printed dots in any one of a number of pre-defined vertical zones. It is stated here as a function of characters printed for user clarity.

New Rib. Detect

The factory default setting is Enable. When the RIBBON INK OUT / CHANGE RIBBON message displays, and a new ribbon is installed with New Ribbon Detect enabled, the Ribbon Minder will automatically reset by opening the platen. If New Ribbon Detect is set to Disable, the Ribbon Minder must be manually reset by using the New Ribbon function.

5

Approaches To Network Printing

Overview

Configuring your network printing is based on the network protocols and host environments you already use or plan to use. It is common to find multiple network protocols co-existing in the same network.

NIC is a multi-protocol device that is able to accommodate many protocols at the same time. The actual print job order operates on a first-in/first-out basis. This means it is possible to configure your NIC using any or all of the methods listed in this manual for use at the same time. This concept is what creates the ability to use powerful printer management tools in parallel with the act of printing. The protocol for a print job and the protocol for the management tool will often be different.

These ideas are also what differentiate networks by size and network protocol use. Some common network arrangements include peer to peer networks and print job servers.

Peer To Peer Networks

Peer to peer networks can be used when you have few machines, few printers, only one network protocol, and when any host can print to the printer. A variation of this is a mini-server which “shares” its printer with the other networked computers in a single room or building. NIC improves flexibility in printer placement and setup by becoming just another “peer,” rather than dedicated to a single machine.

A common peer to peer network arrangement is comprised of Windows® 95/98 with TCP/IP configured to use the netBEUI protocol to connect to the print server. A second common extension of this arrangement is to install a third party LPR PORT MONITOR on each PC and use simple TCP/IP to connect to the print server. If Windows NT is used for the peer computers, LPR is included and is easy to set up. Windows 95/98 does not have such a monitor, but many are available for free for download from the Web.

Print Job Servers

In most larger networks, print jobs usually are managed by designating one protocol and method for printing and then designating specific computers as print job servers, rather than by directing any host running any protocol to the networked printer resource. Computers designated as print job servers have large hard disk space to store print data and spool management software. All clients direct their print job to the computer designated as the print job server rather than the printer; therefore, the client to print job server network protocol used might not be the same as the print job server to NIC. Large network environments today are generally TCP/IP or Novell network protocols or a mixture of the two.

Common examples of larger networks utilizing the P5000LJ Series printers and NIC:

- **Many Windows 95/98 clients directing print jobs to an NT server.** The Windows 95/98 clients, NT server, and P5000LJ Series printer might or might not be in the same physical location, building, or even country. The printer is located based on where its output is needed, not where the jobs originate. Remote printer management tools (PPM, SNMP, etc.) give the same ability to the administrator today that networking provided in the past.
- **Windows 95/98, NT, Novell network client computers direct output to a Unix[®] machine designated as the print job server which spools and manages print jobs.** The designated print server could be an HP e3000, IBM AS/400, Unix (or Linux), or Novell machine.

Logical Printer Architecture

NIC implements a logical printer architecture which gives the system administrator the possibility to configure the print server to handle and act upon the print data in several ways. When a print job comes through the print server, there is a certain logical print path that it follows before it gets to the printer. Each logical print path consists of a sequence of logical steps where extra processing may be performed on the print data before it is sent to the printer. This ability to preprocess the print data before it is sent to the printer allows elimination of printing problems, or implementation of printer enhancements that may be difficult and time consuming to solve or introduce at the system, spool or queue level, yet be simplistic to perform at the print server level.

The logical print path for a print job going through NIC consist of three different phases:

- Phase 1 - The host sends the job to a destination or queue on NIC (e.g. d1prn).
- Phase 2 - The print job passes through the associated "model" (e.g. model "m1") on NIC for any extra processing associated with the model.
- Phase 3 - The processed print job is directed to the printer for output.

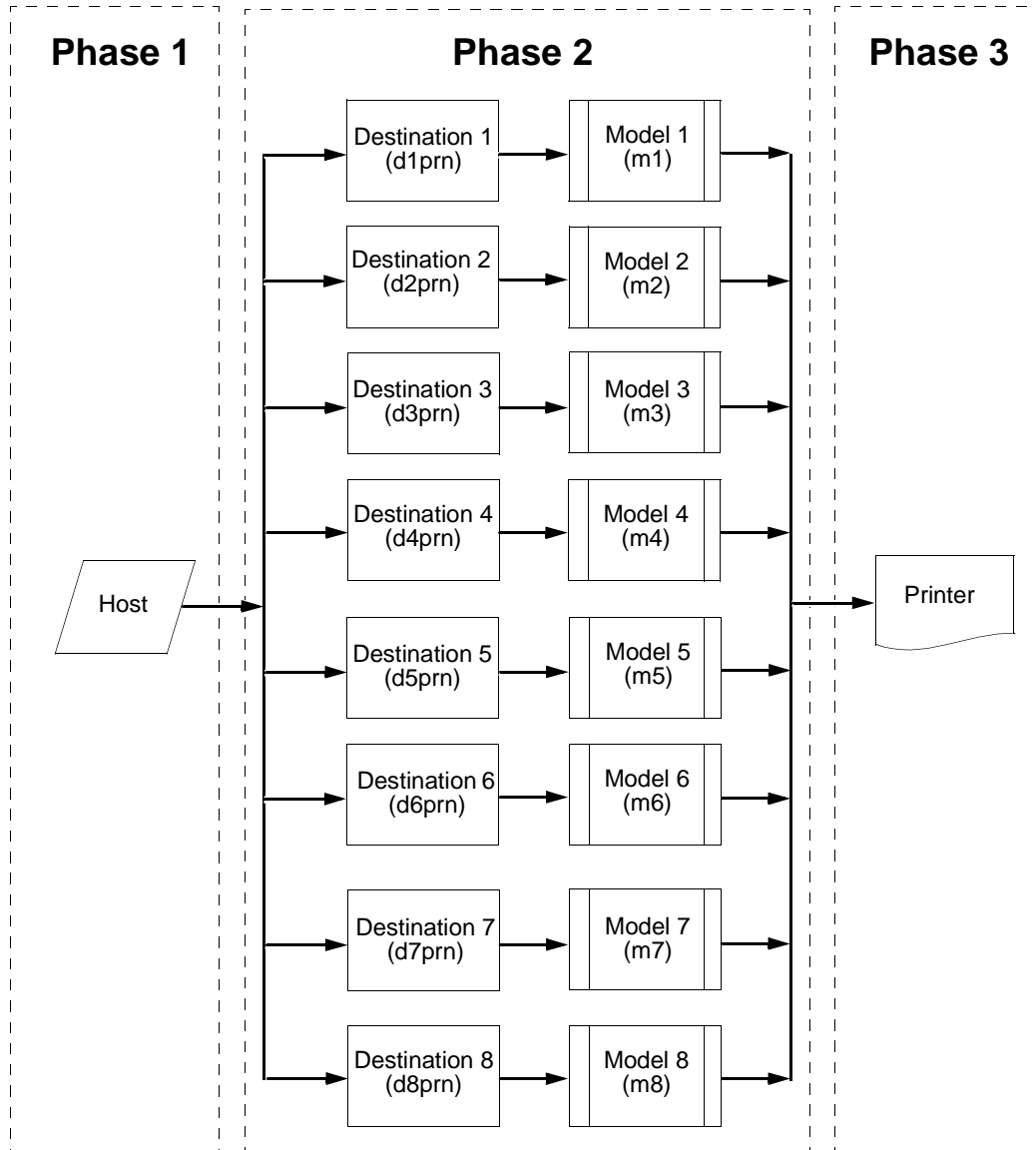

Figure 13. Print Path

Destinations/Queues

For every I/O port on NIC, there is at least one pre-defined logical print queue or destination to accept print jobs destined for it. This includes print jobs that are sent directly to the I/O port, such as port 9100. These queue or destination names are pre-defined but can be changed by the user.

Models

For every destination or queue, there is a pre-defined model associated with it. The model defines how the print job will be processed as it passes through to the printer. Models are a set of mini filters that can be used to modify the print data stream. The functions available for each model are as follows:

1. Insert carriage return after line feed
2. Insert a banner page before or after each print job
3. Insert header strings to
 - print using upper tray's paper
 - printer using lower tray's paper
 - print in landscape mode
 - print in portrait mode
4. Insert trailer strings to
 - reset the printer once the print job completes
 - force the end of the job
 - perform a form feed at the end of the data
5. Log one or all of the following information as each print job passes through the model
 - job ID and username
 - user ID and three messages per job about the start and finish
 - checksum value of the data transferred
 - miscellaneous messages from the printer
 - status of the printer based on the port interface signals
6. Load a specific printer configuration before processing a print job
 - to specify a printer configuration to be associated with a print queue
 - when a job is set to that print queue, the associated printer configuration will be loaded before the job is processed.
 - allows you to define up to four unique and independent printer personalities in a single printer.
 - allows you to effectively have four different printers in one.

6

Embedded NIC Web Page

Overview

The NIC comes with an extremely powerful printer management tool that allows you to monitor, configure, and manage both the printer and its print job. The NIC comes with an embedded web server that allows System Administrators and users access to its printer management capabilities from a standard web browser.

The NIC printer's IP address is used as a URL, similar to the URL of an Internet web page. When a web browser is activated and the printer's IP address is entered, the printer's embedded web server displays its home page, with links to the printer's status and configuration settings.

All of the NIC's configuration settings are protected by a password so unauthorized users cannot make changes. When you try to open any of the NIC's configuration pages, you are asked for your user name and password. At the prompt, enter **root** (unless you have another user configured with root privileges) followed by the associated password. If there is no password, press **ENTER**. For more information on setting passwords, refer to "NIC Security" on page 259.

When you configure settings on the NIC and press the SUBMIT button on the related form, re-power the NIC to ensure the latest settings are in use. To reset the NIC, select System Form from the Configuration Menu and click the REBOOT button.

The embedded NIC Web server gives you the ability to configure the network adapter, monitor printer status, and to manage print jobs. The NIC Web Page structure is divided into several menus as shown in Figure 14.

Configuration

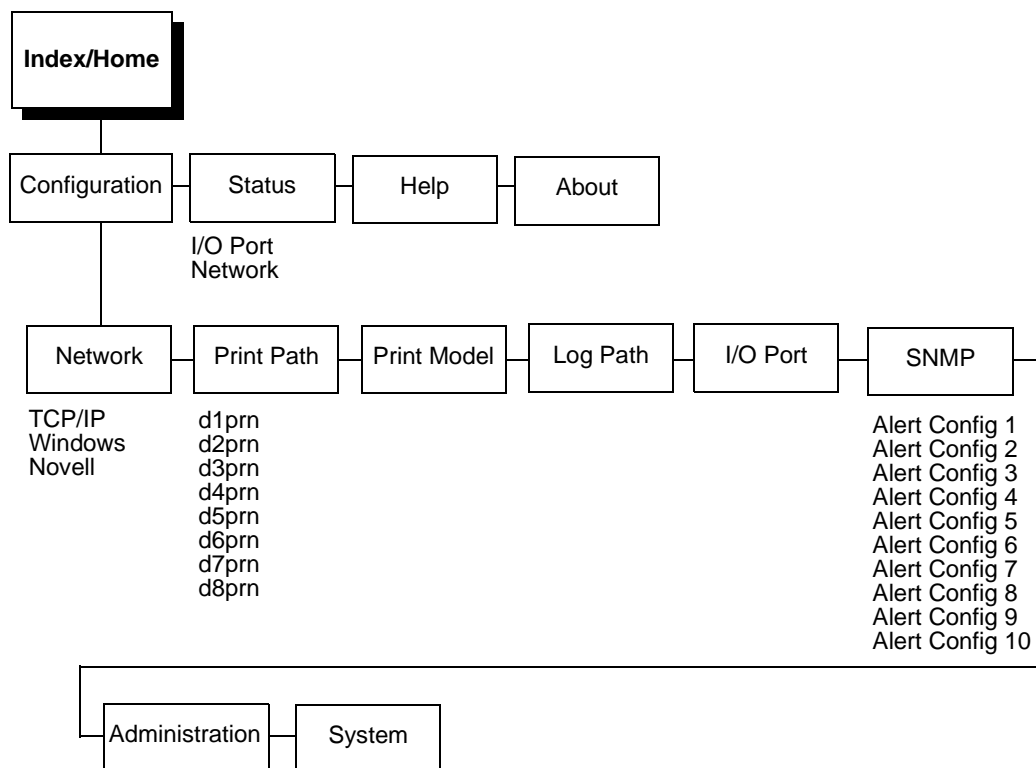

Figure 14. NIC HTML Structure

The Configuration menu items allow you to configure the settings for the following items:

- **Network.** This menu item allows you to change the network setting for each protocol; TCP/IP, NetBIOS over TCP/IP, and Netware.
- **Print Path.** This menu item allows you to change the name of the destination queues, and define how the print job is preprocessed before printing. It allows you to log information, and to specify the SMTP server's IP address.
- **Print Model.** This menu item allows you to specify and display print model settings.
- **Log Path.** This menu item allows you to specify and display log path settings.
- **I/O Port.** This menu item is typically not used. It allows you to configure the operation of the parallel port interface.
- **SNMP.** This menu item allows you to configure the SNMP trap manager settings. It also allows you to define the printer event types to monitor, and the e-mail address that should receive alert notifications.

- **Administration.** This menu item allows you to define or change the printer name, location, description, etc. It also allows you to change the root and guest user passwords.
- **System.** This menu item allows you to reboot the NIC, or restore its settings to the factory default.

Configuration Network

The network configuration allows you to specify the setting for each network protocol. Beside each protocol name is a check box which allows you to enable or disable each protocol depending on your network printing needs.

NOTE: TCP/IP is the only supported protocol which is *always* enabled.

TCP/IP Network

Interface

The two edit fields contain the NIC's IP address and subnet mask. The check boxes enable the RARP and BOOTP protocols, which are alternate methods of assigning IP addresses. On most networks, you want to enter a permanent IP address and subnet mask and disable RARP and BOOTP. However, if your network requires one of these, you should clear the IP address (and possibly the subnet mask) fields and ensure that the appropriate check box is selected.

Routing

The routing table tells the NIC which router or gateway to use to access other subnets or hosts. In most situations, you can add your router's IP address as the default router. All packets destined for other subnets will be forwarded to the default router for delivery to the destination host. If you have more complex routing requirements, add static routing entries for specific hosts or networks in the remaining Routing rows. Packets with IP addresses that match a given Destination and Mask (from the first two fields in a Routing row) route to the router/gateway named in the third field. Packets which do not match any of the listed Destinations and Masks route to the default router if one is set.

Windows Network (NetBIOS TCP/IP)

TCP/IP is used for Windows (i.e. Windows NT, Windows 95, and Windows for Workgroups) printing unless another protocol like IPX is available. Therefore, mandatory TCP/IP settings (i.e. IP address and subnet mask) are necessary on the NIC. Go to "TCP/IP Network" on this form to fill in these settings if you have not done so already.

Workgroup Name

This name specifies which Windows workgroup the NIC resides.

Novell Network

Protocol

Defines the packet structure of transmitted data or the control commands that manage the session, or both.

FrameType

This option determines which framing scheme will be used in processing Novell signals. The different types of Ethernet packet formats include:

- Auto Sensing
- Ethernet II
- Ethernet 802.3
- Ethernet 802.2 (the default)
- 802.2 Snap

Service Type

Allows you to change the Nest Server. The options are:

- Binary
- NDS
- Auto

File Server

Define a Novell file server for the NIC to service as either a PSERVER or an RPRINTER.

NDS

NDS (Novell Directory Services) is a distributed database of network information. An NDS contains information that defines every object on the network. For more information please see your Novell administrator.

Pserver

Define a password for the NIC to use when logging in to the file server as a PSERVER. This is an optional file server security feature.

Rprinter

Define an RPRINTER setup so the NIC knows to service a PSERVER.NLM on a Novell file server. Define the PSERVER.NLM name, the number of the printer serviced by the NIC within this PSERVER.NLM, and the destination on the NIC you want the print jobs to pass through.

Configuration Print Path

The NIC print path is the path a print job takes when it reaches the network adapter. First the job goes to a destination/queue (e.g. d1prn) where it then passes through an associated model (e.g. m1) for extra processing and logpath (e.g. l1) for job and printer logging. Finally the job reaches the NIC's I/O port (e.g. PRN) where it passes through to the attached printer. The "Print Path" form displays one destination's settings at a time. From here, you can then select another destination or you can go directly to an I/O port to configure port settings.

Destination Settings

Name

Name of the destination. The default destination queue names are d1prn, d2prn, d3prn, and d4prn.

Back Channel

I/O port to receive printer feedback when a print job passes through this destination. By default d1prn, d2prn, d3prn, and d4prn have no backchannel.

Services

Define what type(s) of print services the destination will support. By Default all services are enabled.

- **socket.** prints to a TCP port number (e.g. 4000) on the NIC.
- **lpd.** remote printing using the Line Printer Daemon.
- **lpsched.** System V printing using the "lp" command.
- **rprinter.** Novell's remote printer setup.
- **pserver.** Novell's PSERVER setup.
- **netbios.** prints from Windows stations relying on NetBIOS over TCP/IP.
- **ftpd.** prints using the File Transfer Protocol (FTP).

Selected Model

Defines the model configuration that is to be associated with the current destination. The default model names are m1, m2, m3, m4, m5, m6, m7, and m8.

Current Model Settings

Model Type

The option is available on the Print Model web page. For a description, see page 147.

Banner Page

The option is available on the Print Model web page. For a description, see page page 147.

Filter

The option is available on the Print Model web page. For a description, see page 147.

Header String

The option is available on the Print Model web page. For a description, see page 147.

Trailer String

The option is available on the on the Print Model web page. For a description, see page 148.

Printer Configuration

The option is available on the Print Model web page. For a description, see page 148.

Selected Log Path

This option defines the log path configuration that is to be associated with the current destination.

Current Log Path Settings

Log Path Type

The option is available on the Log Path web page. For a description, see page 148.

Log Path Port

The option is available on the Log Path web page. For a description, see page 149.

Configuration - Print Model

Name

Name of the model. The default model names are m1, m2, m3, m4, m5, m6, m7, and m8.

Model Type

Define what processing (if any) will be performed on print jobs passing through the associated destination. If set to "raw", the job will not be touched by the network adapter.

Banner Page

Tell the Ethernet Interface to produce a banner page with each print job. The type of banner page data can be text. You can also specify whether the banner page should come at the front or the end of a print job.

Filter

Specify whether the Ethernet Interface is to add carriage returns to print jobs passing through that contain solitary linefeeds. This is common with Unix text jobs resulting in stair-stepped output.

Header String

Define an escape sequence to be sent to the printer before each print job. For example, you may want to send a sequence to print the job in landscape mode or to a certain tray on the printer. You can specify up to four separate sequences per header string. The Ethernet Interface will execute them in order from top to bottom. If specifying fewer than four sequences, be sure to start at the top leaving undefined fields at the bottom.

The most common sequences are listed on the form:

- Print landscape - tells the printer to print in landscape mode.
- Print portrait - tells the printer to print in portrait mode.

Trailer String

Define an escape sequence to be sent to the printer after each print job. For example, you may want to send a sequence to add a formfeed so you don't have to manually press the formfeed button on the printer. You may also want to tell the printer to reset itself in case you have set a header string which tells the printer to do something special with the job. You can specify up to three separate sequences per trailer string. The Ethernet Interface executes them in order from top to bottom. If specifying fewer than four sequences, be sure to start at the top leaving undefined fields at the bottom.

The most common sequences are listed on the form:

- PCL Reset - tells the printer to reset itself once the data completes
- End of Transmission (EOT) - tells the printer to force the end of the job
- Formfeed - tells the printer to do a formfeed at the end of the data.

Printer Configuration

Specify a printer configuration number to be loaded before processing the print job. This ability to associate a printer configurations to a logical printer model allows you to define up to four unique and independent printer personalities in a single printer. Using this feature, you effectively have four different printers in one.

To associate a printer configuration to the currently selected destination queue, just select the desired printer configuration number from the drop down list. Once a printer configuration have been associated with a destination queue, any print job sent to that destination queue name will cause the printer to load the associated printer configuration before processing the print job.

Configuration - Log Path

Name

Name of the log path. The default names are I1, I2, I3, I4, I5, I6, I7, and I8.

Logpath Type

Define what type of log information will be tracked for each print job passing through the associated destination. The types are:

- job - job ID, username, etc.
- user - user ID and three messages per job about the start and finish
- checksum - value used when troubleshooting integrity of data transferred
- printer - miscellaneous messages from the printer
- i/o port - status of the printer based on the port interface signals.

Logpath Port

Define where logging information for print jobs passing through the associated destination will be reported. The choices are:

- prn - reported to the PRN port
- none - don't report any logging information
- TCP/IP port - to a TCP port number (specified in the edit field)
- syslog - to a host (specified by the IP address in the edit field) running a SYSLOG daemon
- email - to an e-mail address (specified by the e-mail address and the SMTP server IP address edit fields)

NOTE: The values defined in Logpath Type and Logpath Port are common among all destination queue.

Default: no logging turned on.

Configuration - I/O Port

I/O port configuration can be reached through a Print Path destination form (by clicking on a port) or through the I/O Port option under the Configuration Menu.

Parallel Port (PRN)

The parallel port on the Ethernet Interface can have its throughput altered by selecting a particular "Mode". The choices are:

- default - normal throughput rate which will work with most printers
- fast - increase data transfer rate
- test, non-printing - emulate an attached printer though no printer is actually attached

Configuration – SNMP

The SNMP Configuration form allows you to configure SNMP trap managers and the e-mail alert features of NIC. It allows you to configure how SNMP alerts are processed by a SNMP trap manager, an Unix syslog logging daemon, and/or have e-mail notifications sent. Up to 10 SNMP trap managers and e-mail recipients may be specified. Individual alerts fall into one of 12 alert group categories, providing the ability to filter alert notices as desired.

SNMP Manager Alert Posting Settings

Specifies whether alerts from the enabled alert group categories for this configuration will be sent to the SNMP manager. If this option is enabled, the following information must be entered:

- SNMP Manager IP Address - specifies the IP address of the SNMP trap manager
- UDP Port - specifies the UDP port number used by the SNMP trap manager for receiving trap messages. Acceptable values are 162, and 49152 through 65535
- Community Name - up to 15 character string specifying the trap community name.

Syslog Alert Posting Settings

Specifies whether alerts from the enabled alert group categories for this configuration will be sent to the Unix syslog daemon. If this option is enabled, the syslog daemon IP address must be entered in the syslog field in the Logpath Port section under the PrintPath menu item.

Default: Disabled

E-mail Alert Posting Settings

Specifies whether alerts from the enabled alert group categories for this configuration will be sent to the specified e-mail address. If this option is enabled, the following information must be entered:

- E-mail Address - specifies an e-mail address to which alert information will be sent
- Short E-mail Format - specifies whether a short (15-80 character) alert e-mail message should be sent.

If enabled, the message will contain the alert description, the severity level, and device name (unless the length of the message exceeds the Short E-mail Message Length, in which case the message will be truncated).

If disabled, the message will contain additional information including the device name and location, alert description, alert group, and alert severity level, and printer status.

Default: Disabled

- Short E-mail Message Length - Specifies the maximum size of the short e-mail message. Acceptable values are 15 to 80 characters.

Default: 80 characters

- Send Test Message - Provides a way to test the validity of the e-mail address/SMTP server address. If checked, a test message will be sent to the specified e-mail address when the submit button is pressed.

Default: All alert groups are disabled by default.

If the alert message is to be sent to a cellular phone or pager, the Short E-mail Format option should be enabled. Once this option is enabled, you may specify the maximum e-mail message length (15-80 characters). When enabled, the message will contain the alert description, the severity level, and device name (unless the length of the message exceeds the Short E-mail Message Length, in which case the message will be truncated).

If the Short E-mail format is disabled, the message will contain additional information including the device name and location, alert description, alert group, alert severity level, and printer status.

To test the validity of the e-mail address and the SMTP server address, enable the Send Test Message option. If the Send Test Message box is checked, a test message will be sent to the specified e-mail address when the submit button is pressed.

Alert Groups

Specifies which alert groups are enabled for reporting for this configuration. When an alert occurs that is contained in one of the enabled alert groups, it will be posted to the specified SNMP manager, Unix syslog daemon, and/or e-mail address. The following table describes which printer events belongs to which Alert Group.

Default: All alert groups are disabled by default.

Table 13. Alert Groups and Printer Events

Alert Group	Printer Events
Offline	Printer is Offline Hold Print Time Out
Warning	COMM Check Invalid Address CU Time Out CU Not Enabled File System Full File Exist Hex Dump Mode Half Speed Mode Printer Warm Print Head Warm 2B-Toner Density Too High 2C-Toner Density Too Low
Media Input	Load Paper Paper Out Time Out Fanfold Paper Empty No Fanfold Paper 63-CutSheet Feeder Fail Cutsheet Pick Miss No Paper Tray Paper Jam at Entrance Cutsheet Cover Open Cutsheet Paper Empty Tray Mismatch
Media Output	Stacker Full Stacker Jam Time Out Stacker Full Time Out Stacker Fault Time Out Stacker Jam Stacker Fault Stack Over Flow Stack Under Flow Stacker Fail Stacker Interlock Fail Stacker Not Ready

Table 13. Alert Groups and Printer Events

Alert Group	Printer Events
Media Path	Clear Paper Jam Paper Jam Time Out Paper Jam Fuser Paper Jam Exit Cutsheet Path Open Paper Jam at Drum Paper Jam at Fuser Paper Jam at Exit Tractor MTR FWD Speed Error Tracker MTR BKWD Speed Error Paper Jam at Entrance Cutsheet Motor Fail Cutsheet Feeder Fail Clear Jam at Fuser Input Clear Jam at Fuser Exit Clear Jam Near TOF Lever
Marker	Ribbon Stall Time Out Ribbon Ink Out Ribbon Stall Ribbon Drive Shuttle Over Speed Ribbon Fault Ribbon Detected Print Head Up Ribbon Broken Ribbon Load Bad Ribbon Take-up Full 2A-Toner Empty Add Toner Install Toner Cup
Cutter	Cutter Fault Cutter Fail
Barcode	Barcode Fail Specification Barcode Quiet Zone Too Small Barcode Improper Data Format
Scanner	Unscannable Check Media Poor Scanning Check Head and Heat Poor Scanning Inspect Head Poor Scanning Check Media Contrast Too Low Check Media
Intervention	These are error messages that need some kind of user intervention to solve them.
Consumable	Ribbon Low Toner Low

Table 13. Alert Groups and Printer Events

Alert Group	Printer Events
Label	Label Present Gap Not Detected

NOTE: Not all of the alerts are available on all of the printers. The alerts available for monitoring will depend on the printer type and the options installed on the printer.

Configuration - Administration

The Administration Configuration form is broken down into general print server-related settings and password security.

System Information

The System Information form allows you to specify the following information about the printer:

- Name - name given to the print server in Novell and Windows environments. The default name is "M_XXXXXX" where "XXXXXX" equals the last six digits of the network adapter's Ethernet address. (e.g. M_031C1A)
- Description - optional field to help identify the printer's features and capabilities
- Location - optional field to help identify the printer's physical location
- Contact - optional field to help identify the individual or group responsible for the printer.

Passwords

Only a user with root privileges can alter the NIC's settings. Guest users can only view settings but cannot alter them. Both types of users can be assigned passwords. To change a password, type in the old password in the "Old" field. Then type the new password twice: once in the "New" field, and once in the "Confirm" field.

Default: No passwords for root or guest users.

Configuration - System

The System Configuration form allows you to change the NIC 's operation mode. Select "Reboot" to re-power the print server. Select "Default" to reset the print server and have it come up with factory default settings.

Status

The Status menu items allow you to view the current status of both the printer and the network. The submenu items available are as follows:

- I/O Port - this menu item allows you to view the current status of the printer, including the print jobs that are queued or are currently active.
- Network - this menu item allows you to view the current status of the network connection.

Status - I/O Port

The I/O Port Status form allows you to remotely see what is happening on the NIC I/O port. The port's status and a list of active and queued jobs will be displayed. You can cancel a job (as long as you have permission to) by clicking on the Cancel icon beside the desired job. If you see "waiting" in the "Status" line, this indicates the network adapter is either waiting for data from the host or for feedback from the printer. If you see "blocked" in this line, this indicates the printer is not allowing the NIC to send anymore data. The printer could be busy processing data it has already received or it could be in an error state.

The printer status display is automatically refreshed every minute.

NOTE: You cannot cancel a print job with an IPDS Emulation. Do not click the Cancel icon.

Status - Network

This form allows you to view the current status of the network. The statistical data provided is broken down by network protocol. You can use this form to troubleshoot network-related problems.

7

TCP/IP Configuration

TCP/IP NIC Configuration

This configuration procedure assumes you have an existing network and TCP/IP attached to a Windows 95/98/NT, Unix, or other machine.

You will configure network printing by adding the necessary TCP/IP values to the NIC and associating the Print Server as an output port for a Windows printer on a 95/98/NT client or server, or to a print queue or logical printer in Unix, AS/400®, or HP e3000.

Before You Begin

1. You must obtain the IP address and subnet mask to be used for the NIC. In addition, a gateway value may be needed. A gateway is a device that knows how to find other TCP/IP devices on other sections of the network that may need to know about the P5000LJ printer.
2. The NetBEUI/NetBIOS protocol may be used to define the network port for a Windows printer, for example. (Use the following sequence: Start, Settings, Printers, Add, network printer, network path or queue name...) NetBEUI/NetBIOS does not route, which means you must use it on a single network segment, but this setup is ideal for a single network or a small network.

Creating Aliases

All TCP/IP systems are designed to make multiple operations easy by using an alias, which is a logical name to IP/MAC address association. This step is important in the Unix world if DNS (Domain Name Services) is being used; it can also simplify the other environments.

Locate the hosts file. (If you are using Windows 95/98 and have never had a hosts file, you can create one by using Notepad or any other text editor and saving it to the Windows directory.) Edit the file to add your new P5000LJ Printer, and save the file. Rebooting is not necessary.

Location of hosts file:

Windows 95/98	windows
NT	windows/system32/drivers/etc
Unix	/etc
HP e3000	host.net.sys

Example of entries in a hosts file:

```
10.200.30.123 printer1
10.200.30.130 accounting
192.168.2.33 next_state
10.200.30.18 MIS
```

Note

Make the names easy to remember but descriptively useful.

In most Unix systems using DNS, a hosts table is constructed as shown above. The file `nsswitch.conf` or its equivalent is then edited to associate a MAC (hardware address) to an IP address in the hosts file. In doing this, any individual client workstation needs only a single address entry—specifically, the DNS host address—as a ping to `printer1` is actually resolved by the DNS machine and returned to the client workstation. This means an administrator need maintain only one hosts file for all to use, making updating central.

For peer to peer and small networks, using a local hosts table on each workstation can function in place of DNS.

Methods For Setting TCP/IP Values

Methods available to set TCP/IP values vary based the operating environment (see Table 14).

Table 14. Available TCP/IP Setup Methods

Operating Environment	arp	bootp	DHCP
Unix, HP e3000, Windows NT, OS/2	✓	✓	✓
Windows 95/98	✓		
AS/400	✓	✓*	

Note



*AS/400 can use bootp as of OS/400 v4.3

- **arp.** Easy to use but cannot be routed, so printer and host computer must be on same network segment. Requires the use of print server MAC.
- **bootp.** Workhorse method. Can be routed, and allows assigning of IP address, subnet mask, and gateway value in one step.
- **DHCP** (Dynamic Host Configuration Protocol). Easy in concept, but a poor choice for printers, because printers must always have the same IP values. If the MAC value is known, however, DHCP can be used to facilitate the location of print servers.

If you are unsure which method to use, you can use the front panel of the printer to set the TCP/IP values without a live network connection.

For bootp, arp, and NetBEUI/NetBIOS, the MAC address of the NIC is required. If the NIC is pre-installed, the MAC address can be obtained by using the P5000LJ printer diagnostic print test E-Net Test Page, or by using the printer control panel to view the MAC Address value in the ETHERNET PARAMS configuration submenu (see page 125 for details). In addition, a label attached to the rear of the printer shows the MAC address, which reads 00:80:72:xx:yy:zz. This value is also known as the "hardware address" or "ethernet address."

The DHCP is useful to locate a print server. DHCP generally is not useful for using other than NetBEUI/NetBIOS, as most queueing mechanisms need to know the static location (IP address) of a printer, and with each DHCP power on cycle will likely change.

Assign TCP/IP Values

Method 1: Using the Printer Control Panel

All of the basic TCP/IP values can easily be set and stored in the NIC via the printer front panel under the ETHERNET PARAMS menu. Refer to “Configuration Using The Printer Control Panel” on page 68 for detailed instructions.

Set the IP Address, Subnet Mask or Gateway Values, then press the ON LINE key to store those values in the NIC. These steps do not require the printer to be connected to your network.

After setting the TCP/IP values, connect the printer to the designated hub or switch port via UTP cable. With the P5000LJ printer powered on, use a ping to the assigned IP Address for the NIC:

- **Windows 95/98/NT, OS/2.** Open a DOS shell (or OS/2 window) and type:
`ping xxx.xxx.xxx.xxx` using the IP value you assigned above.
- **AS/400.** At a command prompt, type:
`ping 'xxx.xxx.xxx.xxx'` (IP address must be in single quotes).
- **Unix.** At a terminal session command prompt, type:
`ping xxx.xxx.xxx.xxx.`

Note

If you made a hosts table alias name entry (or set up DNS) you can ping the alias instead of having to remember the actual IP Address. Similarly, the alias can be substituted for the URL in telnet sessions or Web browser sessions.

If you receive a “reply received from...” message, then proceed. If you get a “destination unreachable” message or “no reply from...” message, recheck values and cables you have used.

Once you have established a positive ping response, you may wish to use a browser to change or set items (such as the workgroup name to match that of your client network), or to change other values or names or check printer status. To do this, open your browser. In the URL line, enter the IP Address of the NIC and press ENTER. When the P5000LJ Series Printer Web Page displays, click on “Configuration.” When prompted for a user name and ID, enter `root` and press ENTER. Press ENTER again for a blank password. You may now change the workgroup name and other values.

If your web browser is set to use a proxy (or you don't know), use a telnet command session order to finish your setup using store and set commands (refer to Chapter 13, “Commands”).

Use the following example of a telnet session to change the Windows workgroup name in the NIC from “workgroup” (the default) to “Acme.”

For Windows 95/98/NT or OS/2, open a DOS window. For AS/400, start from a command prompt. For Unix, start from a terminal session prompt:

```
telnet xxx.xxx.xxx.xxx
> login
> user 'root' (default user name for configuration)
> anything (default is no password)
> welcome root user (sample response)
> store pserver smb workgroup Acme
> ok
> reset (print server will need about 30 seconds to reset)
session disconnected
```

You should now be able to browse the NIC in "Network Neighborhood," which has resources d1prn, d2prn, d3prn, d4prn.

- The TCP/IP values are not stored in the printer configuration, so it is not necessary to use the printer configuration menu for the above.
- If the printer is attached to your network via UTP cable and you entered a gateway value, then executing the E-Net Test Page will verify your settings and execute a ping to the gateway. A "good" response is "gw-IP is alive" which assures you of a functioning network connection (cable is good, connection is functional, values are correct, all that remains is setting up printing).

Method 2: Setting TCP/IP Values Using A Network

Start with the printer powered off. Have the IP Address, Subnet Mask, and Gateway values ready.

For arp assignment, the syntax is:

```
arp -s ipaddress MAC_address
```

Example using Windows 95/98/NT:

On a DOS command prompt, enter:

```
arp -s 192.168.20.20 00-80-72-09-00-5F
```

(set the static arp value; be certain to replace the IP Address of this example with a valid one of your own)

```
list arp -a
```

(to ensure you have the "static entry")

Example using Unix (not AIX):

On a command prompt, enter:

```
arp -s 192.168.20.20 00:80:72:09:00:5F
```

(set the static arp value; be certain to replace the IP Address of this example with a valid one of your own)

Example using AIX:

On a command prompt, enter:

```
arp -s ether 192.168.20.20 00:80:72:09:00:5F
```

(set the static arp value; be certain to replace the IP Address of this example with a valid one of your own)

Note

Windows uses hyphens to separate the values in the MAC address; Unix and others use colons.

Now power the printer up, and wait a minute or more for the NIC to obtain the address above.

Test by issuing the command `ping IP_address`.

If you do not get a positive ping response, check your arp table entry, and check that the printer is on the same “wire” as you (the same IP address range, different only in the value after the last period). Verify that you have not typed an IP address that you or someone else is already using. If you have, type the command `arp -d IP_address` at a DOS prompt to delete the incorrect entry and then type the correct value.

If you do get a positive ping response, remove the static arp entry (to avoid conflict) by using either telnet or a web browser. At a DOS prompt, type the command `arp -d 192.168.20.20` (with your own IP Address value in place of this one). Then store this value into the NIC.

Telnet

Using a DOS window (or a third party tool capable of a telnet session), use the following:

```
telnet xxx.xxx.xxx.xxx or hosts_table_name
login: root (default)
password: (no password is default)
welcome root user> (ignore warning messages about differences)
store TCP/IP 1 addr from current (save the arp assigned value)
list TCP/IP (you will see your IP address and a subnet address. If the
subnet address is incorrect, use the following command to modify it)
store TCP/IP 1 mask 255.255.255.0 (enter your mask value in place
of this one)
```

If you have a gateway value, enter it now using the following commands:

```
store TCP/IP add default router gateway_value 1
reset (after a minute or so, you should be able to ping the print server)
```

Web Browser

Initiate the Web browser and enter the IP Address or hosts table name in the URL line.

Click on "Configuration."

Log in as **root**, no password.

Enter the values you need for subnet mask and gateway and click "Submit."

Delete the static arp entry: at a DOS prompt, type the command **arp -d 192.168.20.20** (with your own IP Address value in place of this one). Then click on "System Administration" and "Reset Adapter" to store the values

Note



Windows 95/98 pre-winsoc2 TCP/IP has a bug in which an arp entry will not be created unless a valid arp entry exists in the arp table on the client you are using. To ensure you have a valid arp entry, ping your own workstation in the DOS window and type the command **arp -a** to view the arp table before using the **arp -s** command.

Using BOOTP

BOOTP allows you to assign an IP address to the NIC upon bootup. In addition, the BOOTP server can provide additional details such as a default router/gateway address. To configure the NIC with its TCP/IP settings using BOOTP, complete the following steps.

1. On your BOOTP server, make an entry in the `/etc/bootptab` file for the NIC.

Syntax:

```
NICIPname:\  
:sm=netmask:\  
:hd=homedirectory:\  
:bf=null:\  
:gw=defaultgateway:\  
:ht=ethernet:\  
:ha=ethernetaddress:\  
:ip=ipaddress:\  
:ts=timeserver:\  
:to=timezone:
```

Example:

```
spike:\  
:sm=255.255.255.0:\  
:hd=/usr/null:\  
:bf=null:\  
:gw=192.75.11.1:\  
:ht=ethernet:\  
:ha=008072070060:\  
:ip=192.75.11.9:\  
:ts=192.75.11.7:\  
:to=25200:
```

2. Turn the NIC on so that it immediately sends out a BOOTP request. Wait one minute to allow the IP address assignment process to complete. You should see the STAT LED (on the NIC) slow down indicating it knows about an IP address to use.
3. Try to ping the NIC IP address from a network station to see if it can be seen on your network.

Note

You will be able to communicate with the NIC from network stations on different subnets if the print server has been told about its default router/gateway in the BOOTP response from the BOOTP server.

8

HP e3000/NIC Configuration

Overview

This chapter details the HP e3000 Host Configuration setup and NIC setup.

HP e3000 / MPE-XL / MPE / iX: Host Configuration

Note



With the release of MPE/iX version 5.5 and higher, it is now possible to use the spooler on the HP e3000 to control printing on devices attached to a network. *The Native Mode Spooler Reference Manual* (HP P/N 32650-90166, Edition 5, Sept. 1998 or later) and *Configuring and Managing MPE/iX Internet Services* (HP P/N 32650-90835) are essential references to assist you in this configuration.

Follow the instructions below to configure printing to a NIC by using TCP/IP print to socket, sometimes referred to as "native tcpip mode." The configuration parameters are set via entries in the file "npconfig" (npconfig.pub.sys).

1. If you have not already done so, use program sysgen (sysgen.pub.sys) to add the necessary logical device descriptions. Create one logical device for each P5000LJ Series Printer you wish to add:
 - a. log in as **MANAGER.SYS**
 - b. enter the command **:run sysgen.pub.sys**
 - c. at the > prompt, enter **io** to start the I/O configurator
 - d. enter the command
io> ad ldev=xx;id=HPTCPJD;path=NONE
HPTCPJD is the HP-supplied logical network device type.
 - e. enter the **ld xx** configuration command to view the addition, where **xx** is the logical device number you chose in step d.
 - f. enter the commands:
io> hold (to save the I/O configuration)
io> exit (to exit the I/O configurator)

- g. at the `SYSGEN` prompt, enter the commands:

```
SYSGEN> keep
SYSGEN> exit
```
 - h. to have the new configuration take effect, reboot the system with the command, `start norecovery`. It is also possible to configure the device online by using the command, `ioconfig`.
2. Identify the IP address, Subnet mask, and Gateway value to be used for each NIC. These values are necessary for any network printing. Often, only the IP address value will vary from printer to printer.

You can assign these values to NIC by entering the values in the printer control panel (see page 68), or by using the `bootpd` process as described in *Configuring and Managing MPE/iX Internet Services*. If you use `bootpd`, create an entry in the `bootpd` configuration file for each NIC you are adding. For example:

```
printer1: ht=ether: ha=00807209yyyy:
ip=xxx.xxx.xxx.xxx:\
sm=xxx.xxx.xxx.xxx: gw=xxx.xxx.xxx.xxx:
```

Note

Be sure to replace the `xxx` fields with the correct IP Address, Subnet mask, and Gateway mask values you are using.

In this example, the `ha` value is the MAC address of NIC being added. Replace `yyyy` with the last four digits of the MAC address for the individual print server. If NIC is pre-installed, the MAC address can be obtained by using the P5000LJ Series printer diagnostic print test E-Net Test Page, or by using the printer control panel to view the MAC Address value in the ETHERNET PARAMS configuration submenu (displayed on page 125). In addition, a label attached to the rear of the printer will show the MAC address, which reads 00:80:72:xx:yy:zz.

3. Configure the printer so the active emulation is PCL, PCL/PGL, or PCL/VGL, depending on your printer software. This configuration should also be set as the printer's power-up configuration.
4. Log in to NIC using a telnet session. You can use telnet on your HP e3000, or another workstation with TCP/IP installed (such as Windows, etc.), or via a web browser session. Use the following commands to establish a reverse communication channel for PJJ to function:
 - a. `telnet xxx.xxx.xxx.xxx` or `telnet host_name`
(example: `telnet 192.192.192.192` or `telnet LJ50001`)

Note

The `telnet host_name` command will only work if the host's table entry (with the `xxx.xxx.xxx.xxx` format has been defined in the host file of the HP e3000).

- b. log in as user name `root`, no password (or by using the user name and password you may have stored in the adapter).

```
c. set dest dlprn backchannel prn
save
list dest (this will allow you to see your change)
exit
```

5. The npconfig file is read each time the printer commands **spooler nn;start** or **startspool nn** are used, meaning if corrections are needed to the file it is not necessary to restart the HP e3000, only the spooler. Stop the spooler by using a **stopspool** command, then restart it using one of the commands described above.

Create or modify the npconfig file. As a starting point, you can use the system file npconfig.samp.

For each logical network printer that points to a physical NIC using the npconfig file entries, make the following minimum entries (assume a logical device 201 has been set in sysgen):

```
201 ( network_address = xxx.xxx.xxx.xxx
tcp_port_number = 9100
pjl_supported = true
snmp_enabled = false
jam_recovery = false
data_timeout = 30 )
```

The entry **snmp_enabled = false** must be entered as shown.

If you have other HP LaserJet printers already configured while using a global **setup_file** entry, and you experience font or other difficulties with the P5000LJ line matrix printers, create a separate setup file which is empty to override the global entries. This may be required since the P5000LJ printer uses PCL Level II, which is a minimal set of PCL, and the typical HP e3000 global setup file may contain PCL commands beyond those in PCL II. This will not affect your ability to use the P5000LJ printer effectively. The syntax for the setup file is **setup_file = name**.

Use npconfig entries **banner_header** and **banner_trailer** for banner or trailer pages. Be aware that the default value is "true," so banners will print by default.

NIC Configuration Verification

1. Print the Current Configuration in the printer and verify the installed Function Code. Install the latest version via ftp if not present and reenter all printer configurations. The Function Code version installed is listed as "Program File Version xxxx Part No. xxxxxx" at the top of the configuration printout. Ethernet Version is a few lines below the program File version on the configuration printout. The Ethernet firmware version must be 1.1.3 or later and is only copied to the printer when the Function Code is loaded via the Network Interface (via ftp).
2. On the Current Configuration printout:
 - a. Under Host Interface, verify Ethernet is selected and change the buffer size to 8K (from 16K).
 - b. Under Ethernet Parameters, verify the IP address, Subnet mask, and Gateway are correctly listed.
 - c. If you are not using Novell or NetBIOS for network printing, disable Novell and NetBIOS under Ethernet parameters. This avoids unnecessary protocol broadcasts.

Note

When going through the menus, continue pressing the arrow key until the menu you want displays.

3. Print the E-Net Test Page as follows:
 - a. OFFLINE / CONFIG CONTROL
 - b. LEFT ARROW twice to PRINTER DIAGNOSTICS
 - c. DOWN ARROW to PRINTER TESTS
 - d. DOWN ARROW again to SHIFT RECYCLE
 - e. LEFT ARROW to E-NET TEST PAGE (or, if something else displays, press left arrow repeatedly until E-Net Test Page is displayed).
4. Verify the Subnet mask (Netmask) is correct in two locations on the E-Net Test Page: under Network Information and TCP/IP Routing Table. The Netmask must be the same in both locations.

For example, if the desired Netmask is listed as 255 . 255 . 255 . 0 under Network Information, and if the Netmask is listed as 255 . 255 . 255 . 255 under TCP/IP Routing Table, then the Netmask does not match and you must correct the Netmask.

To correct an incorrectly associated Subnet mask (Netmask) complete the following steps:

 - a. Take the printer offline.
 - b. Modify the Gateway from the front panel to the default address of 0 . 0 . 0 . 0.

- c. Place the printer online and wait for the front panel to display "E-Net Ready." This will write the Gateway address to the network I/F NvRam.
 - d. Take the printer offline and enter the desired Gateway address.
 - e. Place the printer online and wait for the front panel to display "E-Net Ready." This will write the Gateway address to the network I/F NvRam.
 - f. Print E-Net Test Page and verify both listed Netmasks are the same and that `xxx.xxx.xxx.xxx is alive` is printed under Default Gateway Ping Test (`xxx.xxx.xxx.xxx` = Gateway IP address).
5. Inspect "Printer Destinations" on the E-Net Test Page. Reprint the E-Net Test Page and verify the backchannel is set to `prn` for the `d1prn` queue. On an HP e3000 host, `prn` must be listed under BACK for the `d1prn` queue so that Printer Job Language (PJL) will operate properly. (PJL must be operational for Page Level Recovery [PLR] to function.) The backchannel for the `d1prn` printer queue can be set with a telnet session from a PC running a DOS session as shown below:
- ```
C:\telnet 15.31.40.147
Network Printer Server Version 1.1.3 (15.31.40.147)
login: root
Password: (carriage return)
Welcome root User
15.31.40.147:root> set dest d1prn backchannel prn
ok
15.31.40.147:root> save
15.31.40.147:root> exit
```
6. The `npconfig.pub.sys` file is loaded each time the spooler is started. Verify the `npconfig.pub.sys` file contains the (`pjl_supported`), (`snmp_enabled`), and (`data_timeout`) lines for each P5000LJ printer. Here is a typical list of the `npconfig.pub.sys` entry for a P5000LJ printer:

| npconfig.pub.sys Listing       | Comments                                 |
|--------------------------------|------------------------------------------|
| 6 Network Address = 192.6.1.71 | IP address - no leading zeros            |
| tcp port number = 9100         | This line optional                       |
| setup file = SETUP6.PUB.SYS    | Optional - specific setup file for LDev6 |
| pjl supported = TRUE           | Required for PLJ to function             |
| snmp enabled = FALSE           | Required                                 |
| data timeout = 30              | Required                                 |
| banner header = false          | Optional - turns off headers             |
| banner trailer = false         | Optional - turns off trailers            |

The line `setup_file = filename` is the file that contains customized setup strings to specify the printer operating mode for this logical device. This file must be an unnumbered file. When no setup file is specified, the default MPE/iX environment or the global setup file is applied at print time to the printer. The spooler will send the contents of the setup file, even if it is empty, which overrides its own default initialization. So, for example, if you want the pitch to be determined by the printer's front panel setting (e.g., CPI 10, etc.), set the `setup_file` to an empty file.

7. Whenever any parameters are changed (PCL-II, Host Interface, etc.) the configuration must be saved. Then, the saved configuration must be designated as the Power Up Configuration. If this step is not performed, the printer will revert to the factory default configuration at power up (parallel I/F – not Ethernet) and communication with the host would become non-functional.

As we have changed some configuration values in this procedure (Host Interface Buffer size), you must save this configuration to a numbered location (1-8) and designate that configuration as the power up configuration. Failure to save and designate the saved configuration as the desired power up configuration will result in problems, such as loss of communication, after powering off/on the printer.

---

## Methods Of Adjusting Paper Position

---

When the HP e3000 spooler is active and the paper needs to be adjusted (the print is too far up or too far down on the page) or replaced, use one of the methods below to set the paper position. You can also defer printing or temporarily stop the spooler (`stopspool nn`) to ensure no print jobs will release.

**Note**

P5000LJ printers have Line Feed (LF), Form Feed (FF), and Set TOF keys on the printer panel. These keys are intended to be used to adjust paper position **before** the start of any print job.

When the HP e3000 spooler owns the printer, the FF, LF, and Set TOF keys do not operate. If you press any of these keys, the message "Invalid Key - Press View" displays. (If you want to check your output, press the View key.) When the HP e3000 spooler does not own the printer, these keys have their normal function.

---

### Method 1

---

Place the printer offline from the control panel, open the printer platen, and manually roll paper back and forth as required via the knob on the tractor shaft. To put the printer back into active service, close the platen, press CLEAR, and place back online. This procedure is safe at any time.

---

## Method 2

---

Place the printer offline from the control panel. Press and hold either the SHIFT+Up arrow or SHIFT+Down arrow to “micro-step” the paper up or down as needed. Place the printer back online.

---

**Note**

The operation of the View key has been enhanced to include a new function. Normally, pressing the View key will move paper six inches up so the print can be viewed, and a second depression of the View key will move the paper down into the print position. This function is helpful when aligning forms.

The new function of the View key is invoked with a long depression of the View key. When the View key is pressed and held, paper will advance three complete forms, allowing tearoff at the rear of the printer. After advancing paper three forms for tearoff, placing the printer ONLINE will move paper downward two forms and printing will resume.

---

## Using Page Level Recovery On P5000LJ Printers

---

The native mode spooler on MPE/iX 5.5 (and later) supports Page Level Recovery (PLR). PLR provides the ability to restart printing at any page of a document due to device problems or a suspended spooler. (Refer to the *HP e3000 MPE/iX Native Mode Spooler Reference Manual* for more information.) Clarification on how it is handled for P5000LJ printers is described below.

---

**Note**

One feature of the Printer Job Language (PJM) spooler is the ability to keep track of pages printed as a part of Page Level Recovery. On a paper jam or paper out condition, the printer control panel displays the page number counted.

---

There are three types of PLR that can occur, and all three use silent run techniques. That is, the data is sent to the printer and the printer interprets it but does not start actual printing until the printer reaches a target starting page specified by the spooler (e.g., the page following the last one printed).

## Restarting at a user-specified page number in a command

Processing of a spool file can be suspended and then resumed. It can be suspended by using the **spooler** command with the **suspend** parameter or by using the **suspendspool** command. It can be resumed with the **spooler** command with the **resume** parameter or by using the **resumespool** command. When the spool file resumes printing, it can start exactly where it left off or at another specified page.

For P5000LJ printers, the optional **offset** parameter in the **spooler** command can only be used to specify an absolute offset (i.e., absence of a + or – sign). When the **offset** parameter is not used, printing resumes where it stopped. When the **offset** parameter is used, a silent run (PLR) will occur up until the specified starting place.

---

**Note**

The CIPER protocol devices (e.g., C256x using the HP-IB interface) allow you to specify the **offset** parameter with the + or – sign. With spooled network printers such as P5000LJ printers, unpredictable results will occur if the **offset** parameter is used with the + or – sign.

---

For example, to suspend spooling and to position 7 pages from the beginning of the spool file, enter the following command:

```
spooler 6;suspend;offset=7
```

In this case, the absence of a + or – sign indicates an absolute offset from the beginning of the spool file.

Because P5000LJ printers are typically connected to the network with the NIC, many of the spooler commands (e.g., those described above) should be avoided for mid-file suspension. This is because of two reasons: 1) a great deal of data is buffered in the network process and must be completed, and, 2) the network connection can be dropped if the printer is ready to receive data but no data is being sent. (Refer to the *HP e3000 MPE/iX Native Mode Spooler Reference Manual*.)

## Restarting at the point of interruption when a device exception occurs

When a device exception occurs, this is an unexpected recovery situation. A device exception includes things such as paper jams, load paper error, etc.

Assume that the P5000LJ printer is connected to the network with the NIC. In order for PLR (silent run) to take place after a device exception and without specifying spooler commands to restart, the printer **must** be power cycled (e.g., after the jam). This is different from the way it may work with other HP printers that support PLR and use an “internal” JetDirect interface. This is also different from the way it works with the C256X printers that use the HP-IB interface. This caveat may be one of the reasons it appears that PLR does not work for P5000LJ printers. Note that printing will start with the page following the last one printed.

## Restarting at the point of interruption when a particular spool file is reprinted after being interrupted previously by a command

In this case, a spool file is reprinted after being interrupted by a command such as `spoolf #0 nnn;defer`. For P5000LJ printers, when the spool file is undeferred, after being interrupted with the deferred option, a silent run (PLR) will occur up until the page following the last one printed.

A spool file can also be interrupted with the `spooler ldev; stop` command, but this command should be avoided for a P5000LJ printer connected to the network with the NIC. This is due to network printing problems with stopping mid-file server.

## HP e3000 / MPE-XL / MPE / iX: DTC Configuration

### MPE-XL / MPE / iX Typical Configuration

Within NMMGR follow the menu:

Open Config

DTS

Go to Profiles

Add or

Modify

Printer Type [22] (21, 22, or 26)

or Printer Type File Name \_\_\_\_\_

Line Speed [9600] (300 through 38400)

Record Width [132] (1 . . . 2048 bytes)

Modem Type [0] (0-None, 1-US, 2-Europe)

Parity [NONE] (None, Even, Odd, 0's, 1's)

Initially Spooled [Y] (Y,N)

Device Class . . . user's choice

Save Data

Prior Screen . . . twice

Go to DTC

Config Card

Assign Profile to LDEV

Save Data

Validate Link/DTX

After successful Validation, run SYSGEN to cross-validate the DTS configuration with the system configuration. In order for any TIO changes to take effect, you must reboot the system.

Within SYSGEN

```
sysgen> io
```

```
io> LD
```

```
io> HO
```

```
sysgen> K . . . (Keep configuration)
```

---

**Note**



Ensure that the P5000LJ Printer configuration matches the system baud rate and parity.

---

---

# 9

# *Windows Configuration*

---

## Overview

This chapter details a complete Windows configuration setup including:

1. Identifying the NIC on the network using TCP/IP as the underlying protocol
2. Configuring the NIC with its mandatory TCP/IP settings (IP address and subnet mask)
3. Configuring a new printer on the Windows station

---

## Windows Environment Description

The NIC supports network printing under Windows environments by using TCP/IP. In a Windows NT<sup>®</sup> setup, pure TCP/IP is used as the network protocol whereas with Windows 95<sup>®</sup> or Windows 98<sup>®</sup>, NetBIOS over TCP/IP is used.

Figure 15 shows two of the most common Windows setups you will see with the NIC. The ideal configuration is a network printer defined on the NT server to be shared by Windows 95 clients. However, any Windows station can also go directly to the NIC.

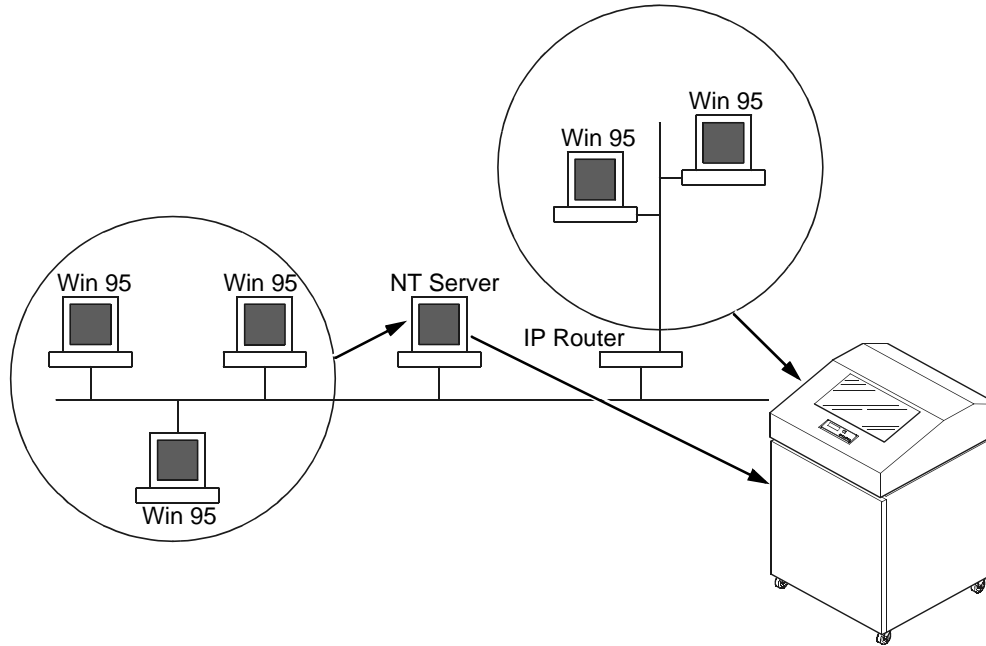

Figure 15. Windows Integration

## Windows NIC Configuration

The IP address and subnet mask are mandatory TCP/IP settings and are needed before the print server can be detected on the network. There are also additional optional settings. This section offers alternative methods for configuring your NIC in a Windows environment and mentions some of the more common optional settings available.

### Mandatory

Since TCP/IP is used for Windows printing, the NIC must be configured with a minimum of an IP address and subnet mask before it can be seen on the network.

### Optional

Additional settings, like routing entries, can be configured. This allows communication across subnets when no other router exists.

Configuration of the NIC can be done from the printer control panel, Web browser, or host commands.



## Communicating Across Routers

---

Since Windows environments rely on TCP/IP to communicate with the NIC, crossing routers becomes an issue.

After following one of the NIC configuration methods mentioned, you should be able to communicate only with the print server from the same subnet. This means any hosts across a router will not see your NIC. In order for hosts across a router to see your NIC, store a default router/gateway within the print server so that any packets destined for another subnet get forwarded to this router automatically. The router (or series of routers) can then take over ensuring the packets get to their final destination on another subnet on your network.

To configure a default router/gateway within the NIC:

1. Load a Web browser on your Windows station and direct it to the URL **`http://P5000LJIPaddress/networkConf.html`** (e.g., **`http://192.75.11.9/networkConf.html`**).

---

**Note**

If prompted for a User ID and password first, type in **root** for the ID and press ENTER at the password prompt since there is no password by default.

---

2. At the Network Configuration HTML form that displays, click in the first field below the “Gateway” heading and type in the IP address of the default router/gateway for the NIC subnet.
3. Click on the SUBMIT button when done and physically repower the print server to make the new settings take effect.

## Changing Workgroup Names

---

Windows environments define groups of related computers as “workgroups.” By default, the NIC belongs to the workgroup called WORKGROUP. However, you may want to change this to suit your network better. To do this:

1. Load a Web browser on your Windows station and direct it to the URL **`http://P5000LJIPaddress/networkConf.html`** (e.g., **`http://192.75.11.9/networkConf.html`**).

---

**Note**

If prompted for a User ID and password first, type in **root** for the ID and press ENTER at the password prompt since there is no password by default.

---

2. At the Network Configuration HTML form that displays, search for the “Windows (NetBIOS TCP/IP)” section and highlight the “Workgroup Name” field.
3. Type in the new workgroup name for the NIC.

- Click SUBMIT button when done and physically repower the print server to make the new settings take effect.

## Changing Destination Names

When defining some printers within Windows environments, the NIC requires that you specify a pre-defined destination rather than any name you would like. For example, when creating a new printer under Windows NT, you are presented with a screen similar to Figure 16.

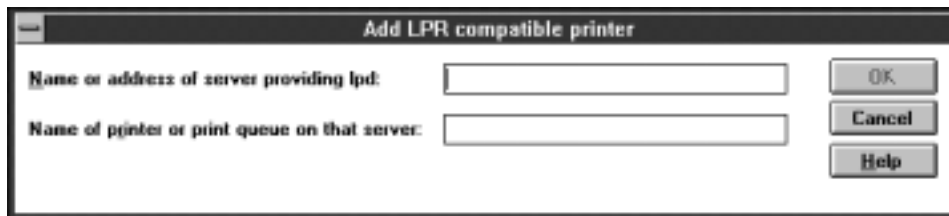

**Figure 16. Windows NT Print Setup Dialogue Box**

The first field requires the IP address for the NIC and the second field must be filled in with a valid destination from the print server (e.g., d1prn). Otherwise, LPR will not be able to access the printer. Table 15 outlines the default destinations to choose from.

**Table 15. NIC Default Destinations**

| Destination | Mapped I/O Port |
|-------------|-----------------|
| d1prn       | PRN             |
| d2prn       | PRN             |
| d3prn       | PRN             |
| d4prn       | PRN             |

This name can be changed to something more meaningful using the built-in HTML forms. To do this:

- Load a Web browser on your Windows station and direct it to the URL `http://P5000LJIPaddress/destConf.html` (e.g., `http://192.75.11.9/destConf.html`)

### Note



If prompted for a User ID and password first, type in **root** for the ID and press ENTER at the password prompt since there is no password by default.

2. At the Print Path Configuration HTML form that displays, select a destination link from the top of the page to bring up the appropriate destination form. By default, you should see a line near the top of the form showing the destinations listed in Table 15.
3. Once the desired destination HTML form displays, highlight the "Name" field and type in the new name for this destination.
4. Click on the SUBMIT button when done and physically repower the print server to make the new setting take effect.

## Windows Host Configuration

This section covers Windows NT, Windows 95, and Windows 3.1 new printer setups.

### Windows NT 3.51 Host Setup

To configure a new printer on a Windows NT 3.51 station:

1. Open the "Control Panel."
2. Double click on "Printers."
3. Select "Create a Printer" from the Printer menu to display the dialogue box in Figure 17.

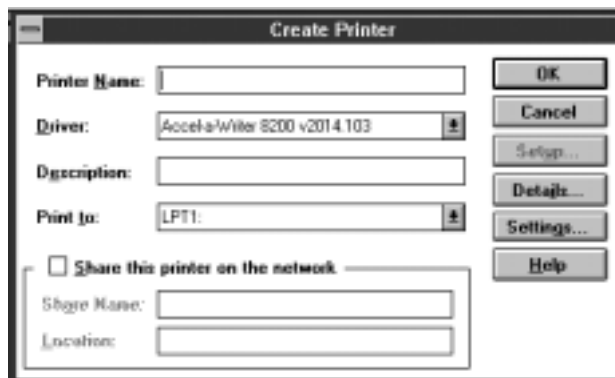

**Figure 17. Create a Printer Dialogue Box**

4. Define a name to represent this print setup and select the appropriate driver for the printer that will be used in this setup. For printer driver choose "generic text" or Epson "FX1050" or "Proprinter" based on print need.
5. Under the "Print To" field, select "Other..."
6. Select "LPR Port" from the list that displays, and click OK to bring up a dialogue box similar to the one found in Figure 18.



**Figure 18. Add LPR Compatible Printer Dialogue Box**

7. Type in the IP address or host name of the NIC in the first field.
8. Type in the name of a pre-defined destination/queue on the NIC in the second field.

---

**Note**



This name must be a name of an existing destination/queue on the NIC, and it must be lowercase by default. You will probably use **dlprn**.

---

9. Click OK when done specifying these two fields.

You now have a new network printer which relies on the standard TCP/IP print protocol, LPD, to print remotely to a printer with the NIC.

## Windows NT 4.0 Host Setup

---

This installation procedure assumes that the NIC adapter is configured with the correct IP address, subnet mask, and gateway (if required). In addition, the administrator can “ping” and telnet to the NIC adapter from the server console.

If this is not the case, use the printer front panel to configure the NIC adapter before proceeding.

1. Select “Settings:Printers” from the Start menu. The Printers window opens.
2. Double-click the “Add Printer” icon. The “Add Printer Wizard” window displays.
3. For Windows NT, skip to the next step.  
For Windows 2000, click “Next.”

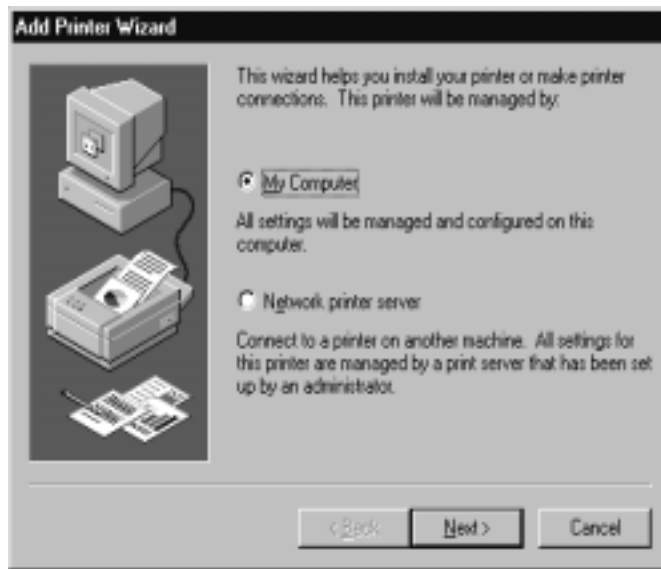

4. For Windows NT, select “My Computer” and click “Next.”  
For Windows 2000, select “Local Printer” and deselect “Automatically detect and install Plug and Play printers.” Then click “Next.”



5. For Windows NT, click “Add Port...”  
For Windows 2000, click “Create a New Port...”

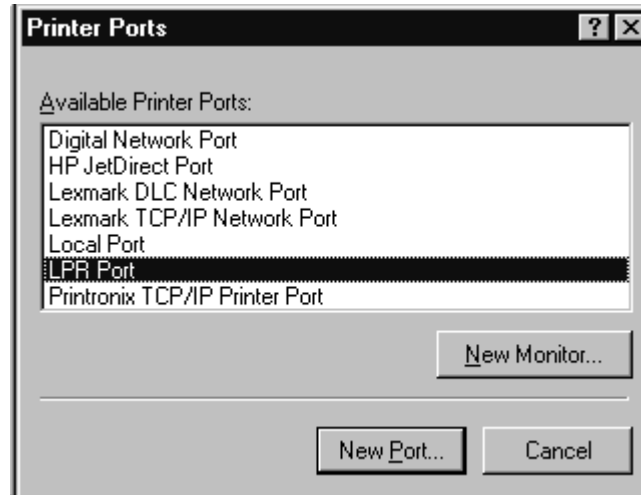

6. For Windows NT, double-click "LPR Port." If LPR Port is not listed, the Microsoft TCP/IP Printing service is not installed. For Windows 2000, select "LPR Port" from the pull down menu and then click "Next." If LPR Port is not listed, it means that the Microsoft TCP/IP Printing service is not installed. To install the Microsoft TCP/IP Printing service, refer to "Installing Microsoft TCP/IP Printing" on page 191.

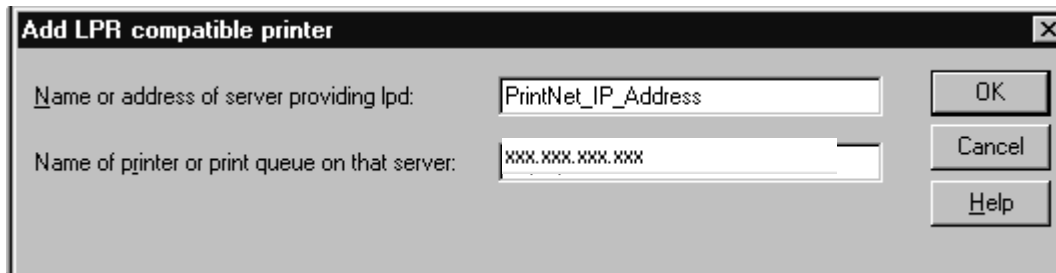

7. In the "Name or address of server providing lpd:" box, enter the IP address of the NIC adapter. In the "Name of printer or print queue on that server:" box, enter the name of the print queue.

**NOTE:** This name must be a name of an existing destination/que on the NIC, and must be lowercase by default. You will probably use **d1prn**.

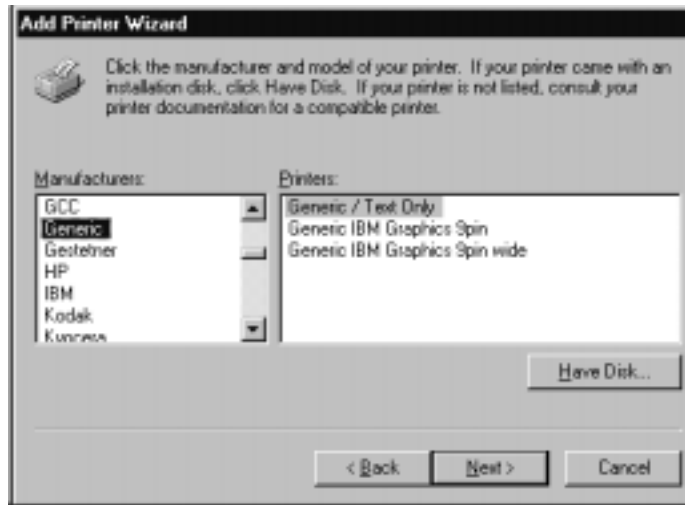

8. Select the “Generic/Text only” printer driver or install the P5000LJ printer driver. The generic driver is good for troubleshooting installation problems. The network administrator can always go back and install the P5000LJ printer driver at a later time. If you have the P5000LJ Utility CD and you want to install the P5000LJ printer driver, click on “Have Disk...”

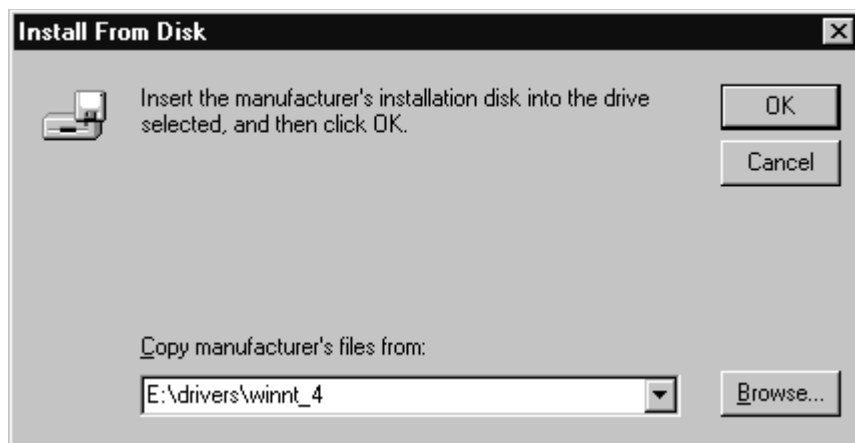

9. In the “Copy manufacturer's files from” box, enter the path to the P5000LJ Utility CD printer driver folder containing the NT driver. Click “OK.”

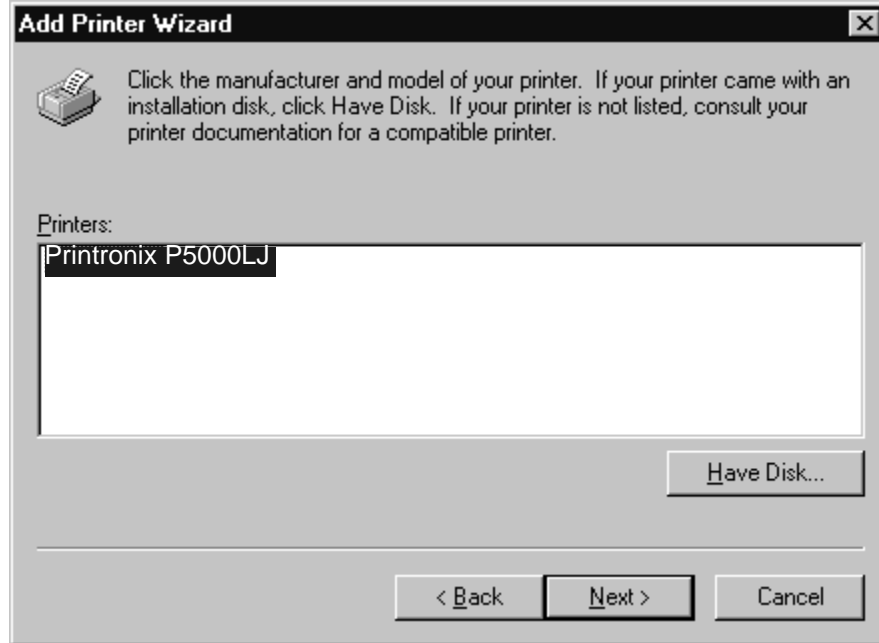

10. Click "Printronix P5000LJ" in the "Printers" dialog box, and then click "Next."

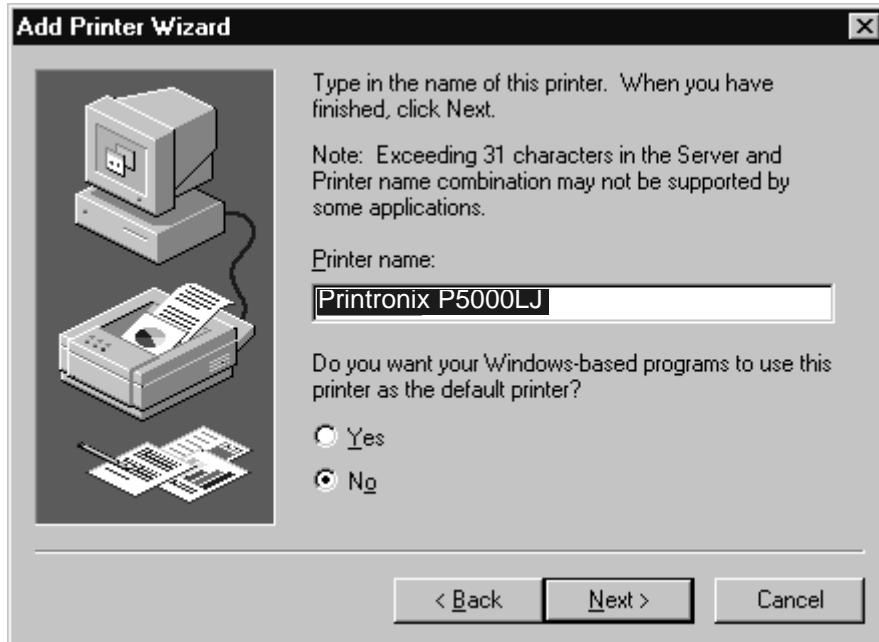

11. In the "Printer name" box, enter a name for this printer. Click "Next."



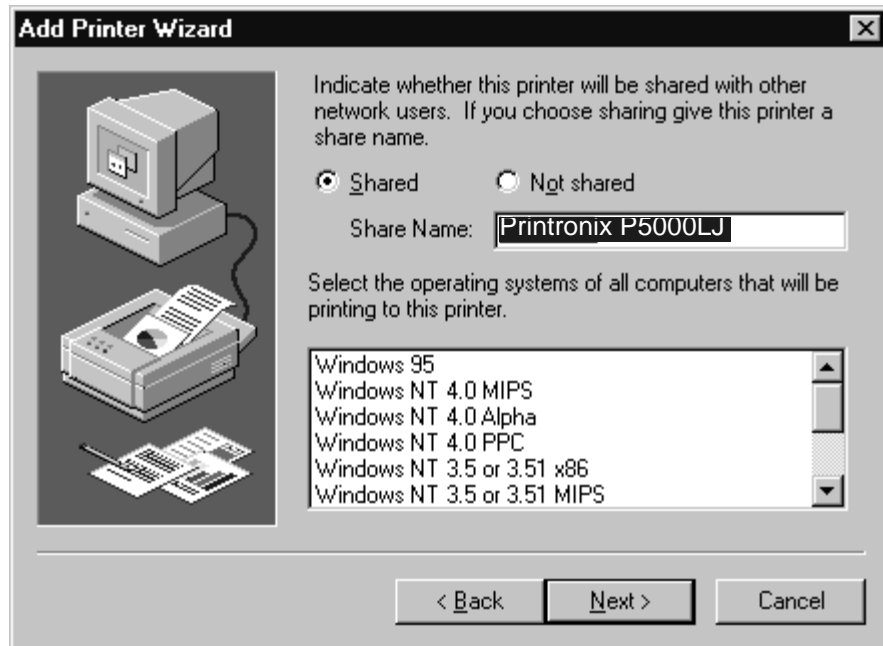

12. Determine if the printer is shared with other network users. If it is shared, the share name and the operating system must be selected.



13. Print a Windows test page.
14. If there are any problems during or after installation, see "Windows NT 4.0 or 2000 Host Setup Problems" on page 191.

## Windows 95/98/ME Host Setup

---

To configure a new printer on a Windows 95 station:

1. Select "Settings:Printers" from the Start menu.
2. Double click on the "Add Printer" icon.
3. Select "Network Printer" from the second window of the Add Printer wizard that loaded.
4. At the next window, click on BROWSE to help fill in the network path of this printer.
5. At the "Browse for Printer" dialogue box that displays, double click on the appropriate workgroup containing the NIC. By default, the print server falls under the workgroup, "WORKGROUP."
6. Continue searching the network until you see the NIC name, M\_XXXXXX, where XXXXXX equals the last six digits of the print server Ethernet address found when a configuration is printed.
7. Once you see the NIC, double click on it to display a list of pre-defined destinations/queues to choose from.
8. Select a destination/queue that will use d1prn.
9. Click OK once you have selected a destination.
10. Back at the network path window, select NEXT since this path should now be filled in for you.
11. At the next window, select the appropriate print driver and click on NEXT.
12. Fill in a name for this new network printer at the next window and decide if you want this to be the default printer. This printer name can be anything you would like as long as it is unique.
13. When prompted for a test page, select either "Yes" or "No" depending on the state of the attached printer and click on FINISH.

Windows may ask for a disk or CD-ROM to load the appropriate printer driver to complete this new printer setup.

There should now be a new printer icon within the Printers folder. This new network printer relies on NetBIOS over TCP/IP as the underlying protocol to print to the NIC.

## Windows 3.1 Host Setup

---

If you are running Windows 3.1 stations on your network, you will need to rely on either TCP/IP or IPX to print to the NIC. If IPX is used, you will have a print queue defined on a Novell file server to which your Windows 3.1 stations will send their print jobs. The NIC will then service this print queue as either a PSERVER or an RPRINTER. Please see Chapter 11, "Novell Configuration" for additional details.

If you want to rely on TCP/IP, you will need a third party TCP stack loaded onto your Windows station since TCP/IP support did not automatically come with Windows until the introduction of Windows NT and Windows 95. You may also be running a third party stack if you decided not to use a Microsoft operating system.

Some common TCP stacks are FTP Software's® OnNet, NetManager's® Chameleon, and Frontier Technologies'® SuperTCP. In each case, they allow your Windows 3.1 station to communicate with other TCP/IP devices. This means you can send print jobs to the NIC as well.

The most common print method offered with Windows TCP stacks is LPR/LPD, a multi-platform remote printing protocol used on everything from PCs to mainframes. The LPR print setup is very simplistic, involving only two parameters:

1. **NIC IP address.** The IP address or host name of the print server you want to print to.
2. **NIC destination/queue.** A pre-defined name on the print server telling the device which I/O port to send the jobs to. The standard name for the PRN port is d1prn. This destination name is case sensitive, and, by default, all names are lowercase.

## Windows Troubleshooting Tips

---

This section provides information on possible solutions to some standard configuration errors. If you require technical support, please have as much of the following information as you can available when you call:

1. What level of software are you running?
2. What type of attachment do you have?
3. What is your host operating system?
4. Give a detailed description of the problem.
5. How often, and when, does the problem occur?
6. Give a detailed description of your network and the components attached.

Please follow these tips to determine what the problem may be with your NIC configuration.

## NIC Cannot Be Found On The Network

---

- Have you assigned the NIC a unique and valid IP address which corresponds with the other IP addresses on your network? For example, are you sure no other device is using this IP address?
- Are you sure you are trying to talk to the NIC from a Windows station on the same subnet? Currently, the print server can only be seen locally unless you configured a routing entry earlier.
- If you look at the back of the printer, is the STAT LED flashing once a second or is it quicker than that? A slower, once-a-second rate tells you that the print server is in fact configured with an IP address. A faster rate says it knows nothing about this so, you may need to try the configuration process again.
- Have you confirmed that the network connection to the NIC is working correctly? Trying different network cables and locations will help narrow down the problem.

## HTML Configuration Forms Will Not Display

---

- Can you ping the NIC from your Windows station? If not, refer to the section titled, "NIC Cannot Be Found On The Network".
- Have you used the correct URL for the NIC home page? It should be **http://P5000LJIPaddress** (e.g., **http://192.75.11.9**)
- Is HTTP support enabled? If not, refer to "Web Browser/HTTP Problem" on page 191.

## Errors Occur When Defining An LPR Printer

---

- Can you ping the NIC from your Windows NT station? If not, refer to the "NIC Cannot Be Found On The Network" section.
- Did you specify the correct IP address or host name for the NIC in the first field of the "Add LPR Compatible Printer" box?
- Did you specify a valid destination/queue on the NIC in the second field of the "Add LPR Compatible Printer" dialogue box? If so, did you also enter it in lowercase letters?
- LPR is available only on Windows NT, not on Windows 95 or 98 (unless third party software is added).

## Cannot Browse The NIC On The Network

---

- Have you looked under the right Windows workgroup? By default, the NIC will be found under “WORKGROUP.”
- Are you able to browse other Windows stations and devices on the network from this same station?
- Has this Windows station been given enough time to update its registry so it can see this newly added workgroup device? Sometimes Windows stations can take considerable time, depending on the size of the network.

## Printer Errors When Printing Or No Output

---

- Is there a large job currently printing taking up all of the printer resources? Usually when printing from Windows 95 stations, a busy printer can cause Windows to display a printer error message. This is because it demands immediate printer attention rather than holding the data until the printer is ready again. The best way around this is to use a central spooling station like an NT server.
- Have you tried restarting the spooler under “Control Panel:Services”? Sometimes this is needed to get printing started.

---

### Note



As a last resort, you may want to reboot the Windows station. Sometimes this is the only option to completely clear this situation. The NIC usually has nothing to do with this problem.

---

## TCP/IP Access Problem

---

If you can ping the printer from a workstation, but you cannot Web browse, Telnet, or print to the printer through the NIC, there may be an incorrect entry in the TCP access list. In order for this workstation to use the NIC in this case, one of two things must happen:

1. The TCP list must have an entry added to grant access to this workstation.
2. All entries must be deleted from the TCP list to grant all workstations/ hosts access to the above TCP services.

To view the current access list, use the printer control panel to access the configuration menu (see Chapter 4 for configuration menu information). From the DIAGNOSTICS/Printer Tests menu choose the E-Net Test Page. When the page prints, look under the “TCP ACCESS TABLE” section for the TCP access list entries.

To add or delete a TCP access list entry, refer to “TCP Access Lists” on page 261.

**Note**

When the following procedure is used, the TCP access list will be cleared, but all IP addresses will need to be entered again after the procedure is complete.

---

To reset all TCP/IP values to the factory defaults when access is impossible:

1. Obtain a printer configuration printout using the control panel. See Chapter 4 for configuration menu information.
2. Power off the printer.
3. On the NIC, place SWITCH 2 in the down position.
4. Power on the printer and wait for the ONLINE state.
5. On the Print Server Interface, place SWITCH 2 in the up position.
6. From a workstation attached to this network segment, create an ARP entry. The NIC IP address and hardware or MAC address are needed. At the workstation enter:

```
arp -s <ipaddress> <MACaddress>
```

```
ping <ipaddress>
```

7. Try to ping this IP address to see if the NIC can be seen on your network. If the interface does not respond, verify you are on the same network segment as the printer and that the ARP entry was created.
8. Telnet into the NIC using the same IP address as above. Log in as **root** with no password.
9. At the system prompt, enter:

```
store tcpip from default
```

```
config http on
```

```
save
```

```
reset
```

**Note**

This will reset all TCP/IP settings to factory default and reset the NIC.

---

10. Power the printer off and then back on.
11. Set the IP address, subnet mask, and default gateway parameters to the desired values.
12. If Web browser access does not work, Telnet into the NIC as **root**. Enter the following command:

```
config http on
```

If you are still experiencing difficulty accessing or browsing the printer, contact technical support.

## Web Browser/HTTP Problem

---

In some cases you may not be able to browse the printer web page simply because the NIC HTTP may be turned off.

If you cannot ping the NIC IP address, make sure the IP Address, subnet mask, and default gateway are set correctly by checking the Ethernet Parameters menu from the operator panel. See Chapter 4 for configuration menu information.

If you can ping the NIC IP address but cannot access the web pages, perform the following procedure to verify the NIC HTTP is turned on.

1. Telnet into the Print Server and log in as `root` with no password.
2. At the system prompt enter the following commands:  

```
config http on
save
reset
```
3. After approximately 30 seconds, point your browser to the Print Server IP address. The printer web pages should now be accessible.

If you are still experiencing difficulty accessing or browsing the printer, contact technical support.

## Windows NT 4.0 or 2000 Host Setup Problems

---

The installation procedure covered earlier in this chapter assumes that the NIC adapter is configured with the correct IP address, subnet mask and gateway (if required), and that the administrator can ping and telnet to the NIC adapter from the server console. If this is *not* the case, use the printer front panel to configure the NIC adapter before proceeding.

## Installing Microsoft TCP/IP Printing

---

The NIC installation for Windows NT 4.0 or 2000 also requires “Microsoft TCP/IP Printing” service on the server. To install this service, click on the Network icon in the Control Panel and click on the “Services” tab. Click on “Add Service” and select “Microsoft TCP/IP printing.”

- Are you logged in as the “Administrator”?  
This installation requires administrator privileges.
- “LPR port” is not listed in step 6.  
Cancel the installation and install Microsoft TCP/IP printing service on the server.
- LPR configuration warning during step 7.

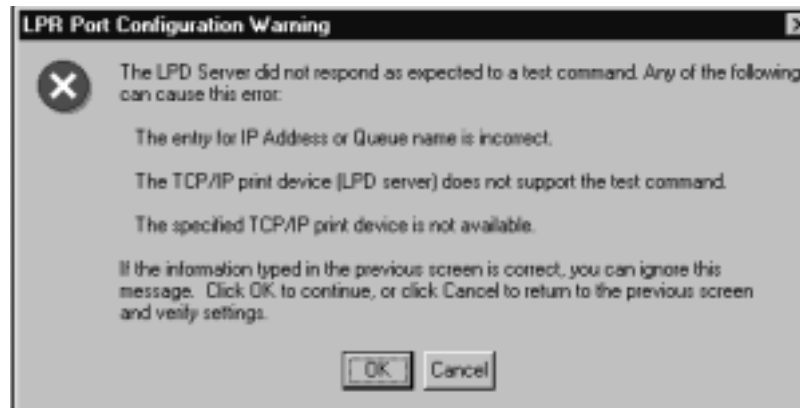

The Ethernet cable is not plugged in, or the printer is not turned on. This message is a communication failure between the NT 2000 server and the NIC. Check cabling, IP address settings, gateway, etc.

- Test page does not print or prints incorrectly.
  1. Is the printer online? Re-send test page.
  2. The print queue name in step 6 should be **d1prn**; however, the name can be changed. To verify the queue names, print an Ethernet Test Page.
  3. The Printronix NT print driver requires P-Series emulation active on the printer. The Generic/Text driver should print in any printer emulation.
  4. Delete then re-install Microsoft TCP/IP Print service on the server.



---

# 10

## *Unix Configuration*

### **Overview**

---

This chapter details a complete Unix setup including:

1. Configuring the NIC with its mandatory TCP/IP settings (i.e., IP address and subnet mask).
2. Configuring the Unix host station with a new printer.

## Unix Environment Description

The NIC supports network printing under various TCP/IP environments including all variations of Unix. Printing can come from multiple hosts directly or through central spooling machines. Figure 19 illustrates this.

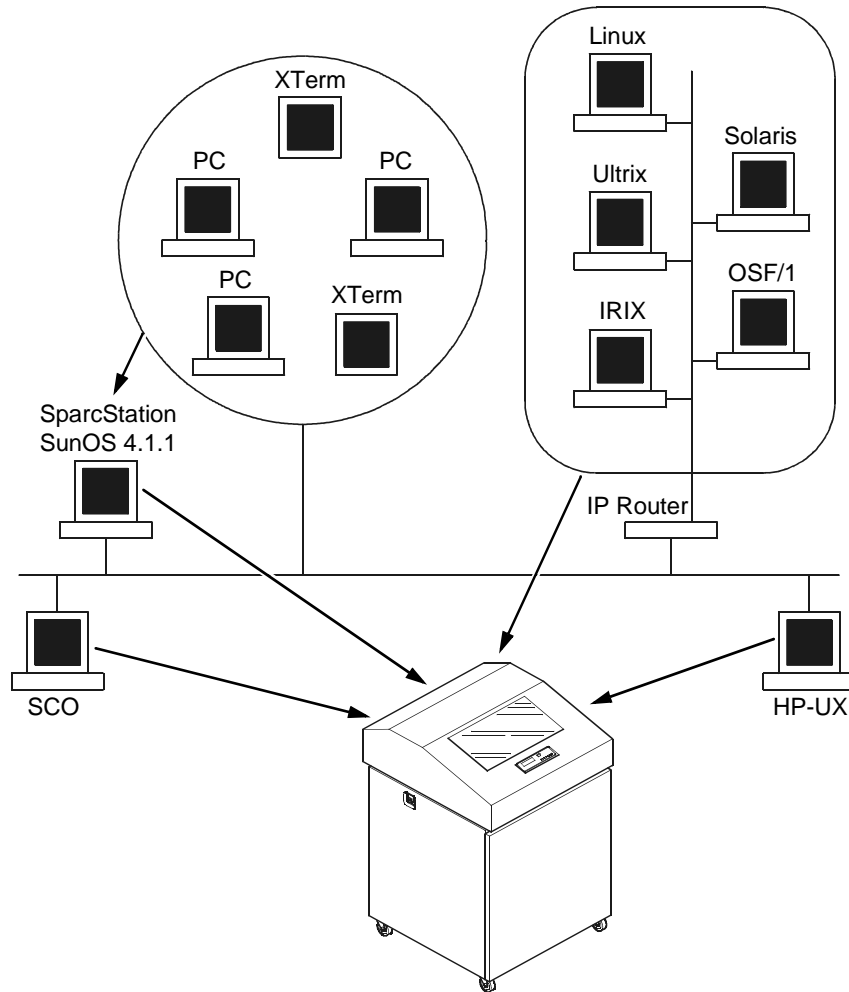

Figure 19. Unix Integration

## Unix NIC Configuration

---

There are mandatory settings needed before the print server can be detected on the network, as well as some additional optional settings. This section offers alternative methods for configuring your NIC and mentions some of the more common optional settings available.

### Mandatory

---

The NIC must be assigned TCP/IP values of IP Address, Subnet Mask, and Gateway Value (if required) before setting up and establishing print queues and logical Unix printers. Refer to Chapter 7, "TCP/IP Configuration" for more information.

Additionally, the file "etc/hosts" on the Unix system (or the DNS server known to the Unix workstation being set up) must be updated to include the IP Address and logical name for the NIC, or a DNS server needs to be set with this information so that the Unix print daemons (software processes) can communicate with the physical NIC.

### Optional

---

Additional settings, like routing entries, can be configured allowing for communication across subnets.

Configuration of the NIC can be done from the control panel or through host commands.

### Communicating Across Routers

---

Since Unix environments rely on TCP/IP to communicate with the NIC, attention must be paid to routing.

After following one of the NIC configuration methods mentioned (other than the BOOTP method), you will most likely only be able to communicate with the print server from the same subnet. This means any host across a router will not be able to see your NIC. In order to communicate across a router, it is possible to store a static default router/gateway within the print server so that any packets destined for another subnet get forwarded to this router automatically. The router (or series of routers) can then take over ensuring the packets get to their final destination on another subnet on your network.

To configure a default router/gateway within the NIC:

1. Use the printer front panel to configure the gateway value.
2. Load a Web browser on your Unix station on the same subnet and direct it to the URL `http://P5000LJIPaddress/networkConf.html` (e.g., `http://192.75.11.9/networkConf.html`)

**Note**

If prompted for a User ID and password first, type in `root` for the ID and press ENTER at the password prompt since there is no default password.

---

3. At the Network Configuration HTML form that displays, click in the first field below the “Gateway” heading and type in the IP address of the default router/gateway for the NIC subnet.
4. Click on the SUBMIT button when done and physically repower the print server to make sure the new setting is in effect.

## Unix Host Configuration

---

There may be times when you would prefer to or have to perform the manual setup steps for a new printer definition. There may also be times when you require a less common print solution such as direct socket capabilities. This section covers these additional setups.

### Printing Setup On HP-UX

---

#### Method 1, SAM

A simple way to set up printing on HP-UX is using SAM, the system administration tool.

1. At the command prompt in a terminal session, start SAM.
2. Double click on “Printers/Plotters.”
3. Under “Actions,” choose “Add Remote Printer.”
4. In the entry panel that opens, make the following entries (remember Unix is case sensitive, so `d1prn` is not the same as `D1PRN`):
  - a. For Printer Name, enter anything you want. This is actually the Unix Queue name, for example, “Accounting.”
  - b. For Remote System Name, enter the DNS/pingable name, for example, “MyP5000LJ.”
  - c. For Remote Printer Name, enter a dest on the P5000LJ, for example, “d1prn.”
  - d. Accept defaults for Remote Cancel model and Remote Status model.
  - e. Check the box next to “Remote Printer is on a BSD system.”
  - f. Click on OK.
5. You will be asked if you want to add the new printer to HP Vue, this is optional. Other optional choices include making this the system printer and allowing anyone to cancel a job.
6. Test your new printer by either a command line print:  
`lp -d Accounting /etc/inetd.conf`  
or, via an application which can be directed to a selected printer.

## Method 2, Command Line

The following procedure requires root privilege.

1. Assume a print queue (aka Unix printer). **Quality** is desired.
2. DNS/IP Address name of NIC.
3. The dest d4prn is to be used on the NIC.
4. The default BSD interface file **rmodel** on the HP-UX system will be used.
5. Issue the following commands (in order shown):  
**lpshut** (stops the print scheduler)  
**lpadmin -pQuality -mrmodel -v/dev/null -ormMyP5000LJ -orpd4prn -ob3** (sets up queue)  
**lpsched** (restarts print scheduler)  
**accept Quality** (allows queue to accept jobs)  
**enable Quality** (allows queue to pass jobs)

Explanation of command line:

- m indicates the model **rmodel** is to be associated with **Quality**
- v indicates the use of **/dev/null** as a file interlock to avoid contention
- orm is the name of remote Print Server
- orp is the name of the remote printer on the remote Print Server
- ob3 declares that the remote Print Server is a BSD type

Other useful commands are **lpstat** and **lpmove [ /usr/lib ]**

6. You can now do a test print:  
**lp -d Quality /etc/inetd.conf**

## HP-UX Typical Configuration, Parallel or Serial Attachment

Printers set up on HP-PB & CIO computers:

**Table 16. Drivers Required**

| Interface | HP-PB | CIO 6 CHANNEL MUX | CIO 16 CHANNEL MUX |
|-----------|-------|-------------------|--------------------|
| Serial    | mux2  | mux0,cio_ca0      | mux0_16,cio,ca0    |
| Parallel  | lpr2  | N/A               | N/A                |

The Drivers shown in this table should be installed in the Kernel Configuration.

## HP-UX Configuration Guidelines

Within SAM follow the menu:

Printers and Plotters

Printers/Plotters

Printer/Plotter Manager menu ... select Actions

Add Local Printer/Plotter

Add parallel Printer/Plotter or

Add serial Printer/Plotter

If parallel printer is selected:

Printer Name

user's choice

Printer Model Interface

user's choice

Printer Device File Name

SAM creates a special file

Printer Class

user's choice

If serial printer is selected:

The system displays the Serial Interface Hardware Paths

Port

select a valid port

Printer Name

user's choice

Printer Model Interface

user's choice

Printer Device File Name

SAM creates a special file

Printer Class

user's choice

## Printing Setup On Sys V

This setup involves any Unix operating system using System V print spooling (e.g., SCO, Solaris®, DG/UX®, Sun 2.5.x, 2.6, 2.7 and similar, etc.). This means an interface file is used for each defined printer and in the case of any System V print setup involving a NIC, the RSHD protocol is used to transfer data from the host to the print server.

To manually configure a new System V printer on a Unix station, create a dummy device file that acts as a locking mechanism between contending print jobs.

Sys V printing is characterized by use of the `lp` printer interface program, `lpsched` printer scheduler, and the use of an interface file. The file `lpadmin` is used in setting up the print queue definition. As of Sun 2.6 and on, the interface file `netstandard` is provided in a generic interface file intended for network print servers such as the NIC. Also as of Sun 2.6 the ability to print to a socket (sometimes called raw tcp) or a remote printer (`dest` for P5000LJ) is provided.

Root access is required to use `lpshut` (stop the print scheduler to add a new printer with `lpadmin`), `lpsched` and `lpadmin`.

For the following example, assume the print queue to be created is `lobby`, and the ping-able IP Address name of the P5000LJ is `LJ_PS1`, and you wish to print to remote printer (`dest`) `d1prn` on `LJ_PS1`. As always with Unix, commands are case-sensitive. Also, be sure to use the `bourne` or `korn` shell, not the `cshell` when using the commands.

The command structure:

- stop print scheduler
- use **lpadmin** to describe print queue (often referred to as the logical Unix printer of the same name)
- start the print scheduler
- enable the print queue
- accept the print queue (allow it to accept print jobs)
- do a test print

Several examples are shown below.

### Example 1: Using the dest d1prn (Sun 2.5.x)

```
lpshut
lpsystem -t bsd lobby
lpadmin -p lobby -v/dev/null (gives file locking)
lpadmin -p lobby -i/usr/lib/lp/model/netstandard
lpadmin -p lobby -sLJ_PS1:d1prn
lpsched
enable lobby
accept lobby
```

### Example 2: Using the dest d1prn (Sun 2.6, 2.7 and Similar)

```
lpshut
lpadmin -p lobby -v/dev/null (gives file locking)
lpadmin -p lobby -i/usr/lib/lp/model/netstandard -o
protocol=bsd
lpadmin -p lobby -sLJ_PS1:d1prn
lpsched
enable lobby
accept lobby
```

### Example 3: Using the raw tcp socket 9100 (Sun 2.1, 2.7 and Similar):

```
lpshut
lpadmin -p lobby -v/dev/null (gives file locking)
lpadmin -p lobby -i/usr/lib/lp/model/netstandard
lpadmin -p lobby -o dest=LJ_PS1:9100 -o protocol=tcp
lpsched
enable lobby
accept lobby
```

To do a test print for either form using the `/etc/hosts` file:

```
lp -d lobby /etc/hosts
```

## LPR/LPD Printing Setup On BSD Systems (Sun 4.x, DEC' Ultrix', Free BSD, etc.)

NIC also supports Unix operating systems which follow a BSD print system (e.g., SunOS 4.1.x). This means a printcap file is used to define all printers available on the host and interface scripts are not commonly used. Instead, LPR/LPD printers are defined.

To manually configure an LPR/LPD printer on a BSD Unix system:

1. Define an entry for this new printer within the printcap file, /etc/printcap.

Syntax:

```
printername:
:sh:pw#80:mx#0:\
:rm=P5000LJname:\
:rp=P5000LJdestination:\
:lp=:\
:sd=/usr/spool/lpd/printername:\
:lf=/usr/spool/lpd/printername/log:\
:af=/usr/spool/lpd/printername/acct:
```

where *printername* is any name you would like to give to this new printer, *P5000LJname* is the host or IP name of the print server, and *P5000LJdestination* is one of the pre-defined destinations/queues on the device.

Example:

```
1000Q:
:sh:pw#80:mx#0:\
:rm=spike:\
:rp=d1prn:\
:lp=:\
:sd=/usr/spool/lpd/ 1000Q:\
:lf=/usr/spool/lpd/ 1000Q/log:\
:af=/usr/spool/lpd/ 1000Q/acct:
```

2. Create the spool directory specified by the **sd=** entry in the printcap entry for this printer.

Example:

```
touch /usr/spool/lpd/ 1000Q
```

3. Create the log and account files specified by the **lf=** and **af=** entries in the printcap entry for this printer.

Example:

```
touch /usr/spool/lpd/1000Q/log
touch /usr/spool/lpd/1000Q/acct
```

4. Create the spool directory to use, set the correct permissions and ownership of the spool directory and objects within it, and start the printer daemon for this new printer:

```
mkdir /usr/spool/lpd/1000Q
chmod -R g+rxw,o+rx /usr/spool/lpd/1000Q
chmod -R daemon.daemon /usr/spool/lpd/1000Q
lpc start 1000Q
```



5. Start the printer daemon for this new printer.

Example:

```
lpc start 1000Q
```

You now have a new printer which relies on LPR/LPD to print to a NIC. Use the following command to test printing:

Syntax:

```
lpr -printername filename
```

Example:

```
lpr -1000Q /etc/hosts
```

## FTP Printing

NIC contains four logical printers (destinations) labeled as d1prn through d4prn. For FTP printing, establish an FTP session, followed by a **put** to the **dest**. Since the printer emulation can be PCL<sup>®</sup>-II, Epson<sup>®</sup>, or Proprinter<sup>®</sup>, be sure the file you **put** to print is both printable and suitable for the printer emulation. Straight text is usable in all cases.

Example:

Type the commands as shown, followed by the enter key. Assume the file you want to print is `/etc/inetd.conf`, which is a simple text file.

```
ftp MyP5000LJ (MyP5000LJ needs to be a ping-able DNS name, or if no
DNS, in the local /etc/hosts file, or it can be a dotted IP Address for the
NIC)
```

at the user prompt, type **root**

at the password prompt, press ENTER (default password for **root** is blank until you change it)

```
cd dest/d1prn
put /etc/inetd.conf
quit
```

### Note



If the file you want to print is a binary file, enter the command **bin** before the **put** command.

## Remote Shell Printing

The NIC is BSD capable, and has an internal lp daemon. Each Unix system has a remote shell function which can be used to access this process: Sun, etc. is **rsh**; UX is **remsh**; AIX is **rcmd**.

For example, printing the file `/etc/inetd.conf` on an HP-UX system to the second logical **dest** in the NIC:

```
remsh MyP5000LJ lp -d d2prn < /etc/inetd.conf
```

You may also use this form:

```
cat /etc/inetd.conf | remsh MyP5000LJ lp -d d2prn
```

In this form of printing the printer status will be fed back as to on/off line.

## Unix Troubleshooting Tips

---

This section provides information on possible solutions to some standard configuration errors. If you require technical support, please have the following information (or as much as possible) when you call:

1. What level of software are you running?
2. What type of attachment do you have?
3. What is your host operating system?
4. Give a detailed description of the problem.
5. How often, and when, does the problem occur?
6. Give a detailed description of your network and the components attached.

Please follow these tips to determine what the problem may be with your NIC configuration.

### Nothing Prints

---

- Can you ping the NIC from your Unix station? If not, please refer to Chapter 7, "TCP/IP Configuration" for information.
- Is the NIC able to communicate with the attached printer? To test this, you can:
  1. `telnet` to the print server (e.g., `telnet 192.75.11.9`) and log in as `root`.
  2. Enter the command `start fox prn`.
  3. Execute `stop prn` right after starting the test.

This test will send the same text line over and over to the attached printer.

- Is the job getting stuck in the Unix host queue? If so, check that the printer is online. If it is, there is a configuration error on the Unix station so creating a new print setup may be needed.
- Is the control panel showing any activity to indicate it is receiving data? If so, but there is nothing printing, check to see if a manual form feed is needed. Also, ensure that the printer can support the type of job coming through.
- Do all jobs fail or just certain ones? For example, is it possible that jobs from a certain application are the only ones to fail? If so, check the type of data it sends to make sure it matches the printer emulation. Check the application printer configuration for mistakes.
- If you are using System V, was the spooler restarted?

## Stair-stepped Output

---

Stair-stepped output is print which starts at the top left of the page but every line thereafter starts a little further over to the right. It also refers to Unix jobs that print one line of text at the top of a page followed by a series of blank pages.

This kind of output happens only with Unix text jobs if carriage return insertion is not incorporated into the print setup. The printer may be told to do a linefeed but the Unix job does not specify anything about a carriage return to follow this.

To fix this, carriage return insertion must be enabled somewhere in the print setup. The easiest and most common location is on the NIC itself within the appropriate model. The feature is called **onlcr** and the command syntax is:

```
set model modelname stty onlcr
save
```

For example, if printing to the destination `d1prn`, the associated model is `m1`. Therefore, the command is:

```
set model m1 stty onlcr
save
```

## No Form Feed Or Extra Page Comes Out

---

Unix text jobs may also have problems outputting the last page of a job especially when the BSD Remote (LPD) print method is used. This means the form feed button has to be pressed on the printer to get this last page out.

To make this process automatic, tell the NIC to handle this task by setting this feature "on" in the appropriate model. The command syntax is:

```
set model modelname trailer $FF
save
```

For example, if printing to the destination `d2prn`, the associated model is `m2`. Therefore, the command is:

```
set model m2 trailer $FF
save
```

For default destination model mappings of the NIC, please see "NIC Naming Schemes" on page 264.



---

# 11

## *Novell Configuration*

### **Overview**

---

This chapter details a complete Novell setup, including:

1. Identifying the NIC on the network.
2. Configuring the NIC with its mandatory print setup settings.
3. Configuring a new print queue on the file server.

See Chapter 12, “Novell Configuration For 10/100Base-T Interfaces” for information about additional options available with the 10/100 Base-T interface.

## Novell Environment Description

The NIC card supports network printing under Novell environments by using IPX. It supports all 3.1X versions of NetWare. Figure 20 provides a Novell setup overview. Version 4.1X is supported under bindery emulation only.

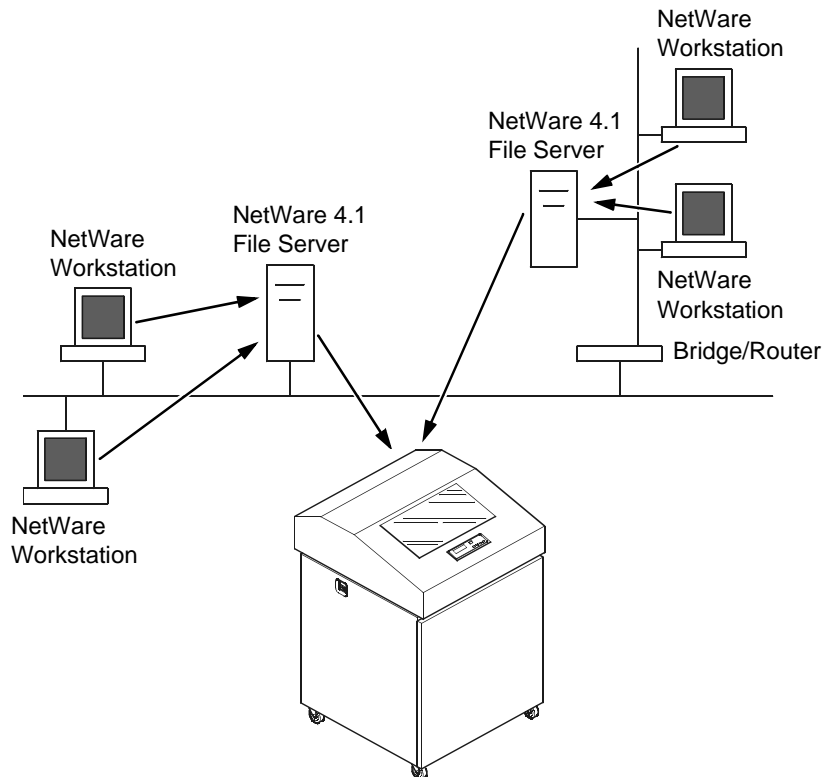

Figure 20. Novell Integration

## Novell NIC Configuration

### Mandatory

Under all Novell environments, the NIC card does not require any network settings to make it visible on the network. Simply plug it in to your network and power it on. However, with a new print queue setup on a Novell file server, there can be some mandatory settings needed on the NIC.

## Optional

Additional settings are available to fine-tune the NIC's Novell functionality. These options include:

- **NDS Context.** The NDS context in which the print server object was created. This option is required if you create the print server object in a different context from the context the file server object for the file server that you logged in with is on.
- **NDS Tree.** The NDS tree the print server object was created in. This is only needed if your environment uses more than one NDS tree.
- **Mode.** The mode the NIC will run in. This can be either auto, bindery, or NDS. The default is auto so that the NIC can autosense which mode it should run in. See "NetWare Version 4.x and 5.x RPRINTER Setup" on page 213 for information on what to do when using both bindery and NDS file servers at the same time.
- **Preferred File Server.** In a bindery setup, this specifies the file server that the print server object was created on. In an NDS setup, this specifies a file server(s) that the print server object resides on. Since NDS is distributed, most administrators will not know which file server(s) the print server object is actually stored on, so in most NDS environments this option is not used.

See Chapter 12, "Novell Configuration For 10/100Base-T Interfaces" for additional information about these options.

## Using HTML Forms

When defining a new print queue on a Novell file server, a new print server must be defined to represent the NIC. This name must match the pre-defined name given to the print server. By default, this name is in the format `M_XXXXXX` where `XXXXXX` equals the last six digits of the NIC address found on a configuration printout or control panel settings under Ethernet parameters, MAC Address (e.g., `M_071C1A`)

To use the HTML forms to define a print queue, do the following:

1. Load a Web browser on a network station that can communicate with the print server over TCP/IP. The command to change the print server name is:

Syntax:

```
store pserver name newname
```

Example to change the name to `micro1`:

```
store pserver name micro1
```

2. Direct your Web browser to URL  
`http://P5000LJIPaddress/adminConf.html`  
 (e.g., `http://192.75.11.9/adminConf.html`)

**Note**

If prompted for a User ID and password first, type in `root` for the ID and press ENTER at the password prompt since there is no password by default.

3. At the Administration Configuration HTML form that displays, highlight the field beside the "Name" heading and type in the new name of the print server.
4. Click on the SUBMIT button when done and physically repower the printer to make the new setting take effect.

---

## Novell Host Configuration

Under all versions of NetWare<sup>®</sup>, both PSERVER and RPRINTER setups are supported by the NIC. Since a PSERVER setup is the most common, you will find the necessary steps to configure the NIC as a PSERVER shown first. Configuration for RPRINTER and NPRINTER setup follow the PSERVER information.

---

**Note**

The NIC can service up to four printers on one file server. It can not service multiple file servers at one time.

---

### NetWare Version 3.x PSERVER Setup

To configure a print queue on a NetWare 3.1x network:

1. Log on to the Novell file server as supervisor.
2. Enter PCONSOLE.
3. Select "Print Queue Information" from the PCONSOLE Main Menu.
4. Press INSERT to add a new queue to the list of currently defined queues showing.
5. Type in the name of this new queue when prompted and press ENTER. This can be any name you would like.
6. Press ESCAPE to return to the Main Menu.
7. Select "Print Server Information" and press ENTER.
8. Press INSERT when the list of existing print servers displays.
9. Type the name of the NIC when prompted for a print server name and press ENTER when done. By default, the NIC is named `M_XXXXXX` where `XXXXXX` equals the last six digits of the print server Ethernet address found on configuration printouts or reading MAC address on control panel. (e.g., `M_071C1A`).
10. Back at the print server list, select this newly defined NIC and press ENTER.



11. Select "Print Server Configuration" from the menu that displays.
12. Select "Printer Configuration" from the next menu to display a list of configured printers.
13. Select the first item listed as "NOT INSTALLED" and press ENTER.
14. At the printer configuration window, type in the name for this new printer. This name must be one of the pre-defined destinations/queues on the NIC. This will normally be "d1prn."
15. Go to the "Type" field and press ENTER to see the possible choices.
16. Select "Defined Elsewhere" from this list.
17. When done, press ESCAPE and select "Yes" to save the changes to this new printer.
18. Press ESCAPE again to return to the Print Server Configuration menu.
19. Select "Queues Serviced by Printer."
20. Select this new printer from the printer list that displays and press ENTER.
21. At the empty queue list that displays, press INSERT.
22. Select the queue created in step 5 and press ENTER.
23. When prompted for the priority, press ENTER to select the default or select a priority.
24. Press ESCAPE until back at the PCONSOLE Main Menu.
25. Repower the printer.
26. Wait two minutes and then select "Print Queue Information" from the PCONSOLE Main Menu.
27. Select this new queue from the menu that displays. Select "Currently Attached Servers" to see which print server is servicing this queue.

At this point, the NIC name (e.g., M\_071C1A) should show within this window. This means the NIC knows about this new Novell print queue it must service as a PSERVER. Therefore, it will poll this queue regularly looking for jobs to print.

---

**Note**



The NIC can service up to four printers on one file server. It can not service multiple file servers at one time.

---

## NetWare Version 3.x RPRINTER Setup

These steps are for Novell environments with Netware 3.x (or earlier) file servers.

To configure a new RPRINTER on a NetWare 3.x network:

1. Log in to the NIC command shell, npsh, as root.

If you have TCP/IP available and this print server already has an IP address stored within it, you can use the built-in HTML configuration forms or a Telnet session. Please see "Configuration Alternatives" on page 69 for additional details. If you have only Novell available, you will need to use a PC, laptop, or terminal.

### Note



If you use HTML configuration, you will need to go to the Network Configuration HTML form `http://P5000LJIPaddress/networkConf.html` (e.g., `http://192.75.11.9/networkConf.html`) and look under the "Novell" section. The settings in the following step are found there. If using a Telnet session, you will need to manually execute the commands listed in the next step.

2. Store the RPRINTER settings on the NIC. This will refer to an existing PSERVER.NLM on the file server or to one that you will create later in these steps.  
Syntax:  

```
store rprinter add PSERVERname printernumber
P5000LJdestination
```

Example for an RPRINTER servicing printer **0** of the PSERVER.NLM called `pserver1` and sending jobs to the NIC destination `d1prn`:  

```
store rprinter add pserver1 0 d1prn
```
3. Leave this NIC login session and log on to the NetWare 3.x file server as Supervisor.
4. Load a PSERVER.NLM if there is not one loaded already. This will be the PSERVER that the NIC services as an RPRINTER so it must match the PSERVER name given in step 2.
5. Enter PCONSOLE.
6. Select "Print Queue Information" from the PCONSOLE Main Menu.
7. Press INSERT to add a new queue to the list of currently defined queues.
8. Type in the name of this new queue when prompted and press ENTER. This can be any name you would like.
9. Press ESCAPE to return to the Main Menu.
10. Select "Print Server Information" and press ENTER.
11. Press INSERT when the list of existing print servers displays.
12. Select the print server that you want the Print Server to service as an RPRINTER. This is the PSERVER.NLM loaded in step 4.

13. Select "Print Server Configuration" from the menu that displays.
14. Select "Printer Configuration" from the next menu to display a list of configured printers.
15. Select an item from the list (e.g., either an existing printer name or a "Not Installed" one) to display the printer configuration window.
16. Assign a name (if not an existing printer) to this printer.
17. At the "Type" field, select "Remote Other/Unknown."
18. Press ESCAPE to save the changes.
19. Press ESCAPE until back at the Print Server Configuration menu.
20. Select "Queues Serviced by Printer" to display a list of defined printers.
21. Select the printer you just defined and press ENTER.
22. At the list of queues that displays, press INSERT to add a queue to the list.
23. Select the queue defined and press ENTER.
24. When prompted for a priority, press ENTER to select the default or select a priority.
25. Press ESCAPE until you have exited PCONSOLE.
26. Reload the PSERVER.NLM that the NIC is to service as an RPRINTER.
27. Repower the Print Server by turning the printer off and then on.
28. Wait two minutes and then check your PSERVER to see if the appropriate printer is being serviced. The PSERVER should indicate that the printer is "Waiting for job."

At this point, the NIC knows to receive any jobs this PSERVER.NLM has to send to it through the defined printer.

## **NetWare Version 4.x and 5.x PSERVER Setup**

---

NIC destinations are case sensitive and will not be recognized if they are typed incorrectly. By default, they are all lower case. If you are setting up a NetWare 4 or 5 environment, the destination must be renamed to uppercase to match the PCONSOLE entry.

The NIC can be used in a NetWare 4 or 5 environment with either of the following options:

- Set the NIC up as a PSERVER, replacing a dedicated printer.
- Set the NIC up as an RPRINTER, interacting with an existing PSERVER (see page 213).

Following a PSERVER setup, bindery emulation is required. To configure the NIC as a PSERVER in a NetWare 4 environment:

1. Log in to the Novell as supervisor.
2. Enter **PCONSOLE**.
3. Press F4.
4. Select "Print Queues."

5. Press INSERT to add a queue.
6. Type in a new queue name and press ENTER.
7. Press ESCAPE.
8. Select "Print Servers."
9. Press INSERT to add the new print server.
10. Type the name of the NIC. By default, it is M\_XXXXXX where XXXXXX equals the last six digits of the Ethernet address (e.g., M\_000BF5).
11. Select this new print server and press ENTER.
12. Select "Printers."
13. Press INSERT to add a printer to the list.
14. Type in the name of one of the default destinations on the unit for the "Name" field and go to the type field.
15. Press ENTER at this field and select "Defined Elsewhere." If "Defined Elsewhere" is not available, choose "Parallel."
16. Press ENTER on the "Print Queues Assigned" field.
17. Press INSERT to display all queues; select the one you defined in step 6. Then press ENTER.
18. Select a priority and press ENTER. Priority 1 should be sufficient.
19. Press ESCAPE until you are back to Main Menu.
20. Reboot the Print Server by repowering the printer.
21. Check the "Currently Attached Servers" and verify the print server is active.
22. Press ESCAPE until you are out of the PCONSOLE.

Even though the entire print set up is done through PCONSOLE, you may want to communicate directly with the print server in order to modify settings, monitor the unit, etc. To communicate with the print server, the optional host software, **npsh.exe**, may be used. **npsh.exe** is a DOS executable program that can be run from a DOS prompt on a NetWare workstation.

**npsh.exe** performs the following:

**npsh nvplist**

Lists all of the NIC devices on the network; each name is in the default format M\_XXXXXX (where XXXXXX equals the last six digits of the unit Ethernet address). This is regardless of whether it is configured as a PSERVER or an RPRINTER.

**npsh unitname**

Starts a Telnet-like session with the named print server, allowing you to configure, monitor, and troubleshoot the unit with the built-in command set.

**npsh unitname command**

Initiates a single Command with guest access only to the unit instead of entering into a complete session.

To communicate with the unit using **npsh.exe**:

- a. From a DOS prompt on a Novell workstation, begin an npsh session with the unit.

**npsh unitname**

Starts a Telnet-like session with the named print server with guest access only.

- b. To obtain root access to the unit, type:

**supervisor**

A standard login screen is displayed prompting you for the login name and password.

- c. Login to the unit as root user.

**root**

Root users require the use of a password as configured in the unit user list.

- d. Enter the password. If this password is not yet set, press enter at the password prompt. Otherwise, enter the password that is already stored in the unit.

**password**

You are now logged in to the unit as a root user and can access any npsh command on the unit.

---

**Note**

Because **npsh.exe** makes use of broadcasts, you may have problems communicating across a router.

---

## **NetWare Version 4.x and 5.x RPRINTER Setup**

---

NIC can be configured to service both RPRINTER, NDS mode, and PSERVER, bindery mode.

Use the following procedure to set up an RPRINTER form of attachment on a 4.x or 5.x server:

1. NIC requires a bindery server login on the 4.x or 5.x as the first step to servicing RPRINTER. This bindery login is necessary for registering the NIC PSERVER name; no bindery queues or printers are set up. Using PCONSOLE, bindery mode, create a bindery printer server object whose name matches that of the NIC at the root context of the 4.x or 5.x box (i.e., M\_03092B). After creating the bindery PrintServer on the 4.x or 5.x server, reboot NIC and use the **debug Novell pserver** command via a Telnet or npsh session, or print the E-Net Test Page out to make sure there is a successful server login.
2. Using either PCONSOLE in NDS mode, or NWADMIN:
  - a. create an NDS queue (any name you want), or simply use an existing one;
  - b. create a print server to use (any valid name, or choose one already in existence);

- c. create a printer object to use with the print server object you chose or created, and attach it to the chosen queue;

**Note**

The 4.x or 5.x queue name, print server name, and printer object don't have to match any NIC name; multiple printers can be defined, but only one print server can be attached to.

Example:

```
NDS queue name: Finance
NDS print server name: Fin_Q
NDS printer name: Fin_Prt_1
NDS printer name: Accounting_Prt_1
```

3. At a 4.x or 5.x console session, if a `pserver.nlm` session is already running for `Fin_Q`, first unload it, then reload it to find the new objects, or, simply issue `load pserver Fin_Q`.

If you are successful the print server console screen will show a “printer status” option. In the “printer status” window, note the numbers assigned to the printers you created. Assume for our example that one printer previously existed (number 0), and we are adding two more, whose numbers became 1, and 2.

On the load command you must strictly follow case of the name (this is not required on the NIC).

4. Via a Telnet or `npsh` session create RPRINTER attachments:

```
store rprinter add Fin_Q 1 d1prn
```

This command assigns destination `d1prn` as the RPRINTER 1 service path.

```
store rprinter add Fin_Q 2 d4prn
```

This command assigns destination `d4prn` as the RPRINTER 2 service path.

For NIC entries, case does not have to be observed. Also, if you want to change the destination names from `dxprn`, do so first with the `set dest dest name new name` command, being sure to use the save command so these reappear after a reboot.

5. Reboot the NIC adapter (power the printer off and on, or use the `reset` command) so the new RPRINTER service names are broadcast.
6. Open a Telnet or `npsh` session and log into NIC. Wait a minute or two, then use the `list rprinter` command, and you should see your entries. You could also do this by looking at the connection status on the 4.x or 5.x PSERVER printer status entries.

7. If you add, delete or change RPRINTER entries on NIC or 4.x or 5.x console, you should always unload and reload the pserver.nlm module to register the changes. The NIC can be configured and ready before the pserver.nlm is reloaded, or NIC can be reset after pserver.nlm is reloaded.
8. A web browser can also be used to see the RPRINTER attachments, etc. and status.

## Novell Troubleshooting Tips

---

This section provides information on possible solutions to some standard configuration errors. If you require technical support, please have as much of the following information available when you call:

1. What level of software are you running?
2. What type of attachment do you have?
3. What is your host operating system?
4. Give a detailed description of the problem.
5. How often, and when, does the problem occur?
6. Give a detailed description of your network and the components attached.

Please follow these tips to determine what the problem may be with your NIC configuration.

### NetWare 3.x - No PSERVER Connection

---

- Has the NIC been power cycled once the PCONSOLE steps were completed? This will make the print server boot up and realize which print queue and file server it needs to service.
- Is the NIC already servicing a queue on another file server? If so, it can not service another file server at the same time.
- When defining a new print server within PCONSOLE, did you use the correct name for the NIC (e.g., M\_071C1A)? By default, it only recognizes itself as M\_xxxxxx where xxxxxx equals the last six digits of its Ethernet address found on the configuration printout.
- When defining a new printer name within PCONSOLE, did you use a pre-defined destination/queue rather than a name of your own? By default, the NIC only recognizes names like "d1prn." All other names will be ignored by the device.
- Is the NIC in Bindery mode as seen under the `list pserver` output on the device? If servicing only a NetWare 3.x file server, it must be set to handle Bindery services. The default setting is "Bindery."
- Is there an available NetWare user license for the NIC to use while it acts as a PSERVER? Every PSERVER takes up one user license since it logs in to the Novell file server.

- Have you given the connection process some time after repowering the NIC? In larger Novell environments, the file server identification and connection process can take several minutes.

## **NetWare 4.x and 5.x - No PSERVER Connection**

---

- Has the NIC been power cycled once the PCONSOLE steps were completed? This will make the print server boot up and realize which print queue and file server it needs to service.
- Is the NIC already servicing a queue on another file server? If so, it can not service another file server at the same time.
- When defining a new print server within PCONSOLE, did you use the correct name for the NIC (e.g., M\_071C1A)? By default, it only recognizes itself as M\_XXXXXX where XXXXXX equals the last six digits of its Ethernet address found on the configuration printout.
- When defining a new printer name within PCONSOLE, did you use a pre-defined destination/queue rather than a name of your own? By default, the NIC only recognizes names like "d1prn." All other names will be ignored by the device.
- Is the NIC in Bindery mode as seen under the `list pserver` output on the device? If servicing only a NetWare 4.x file server, it must be set to handle Bindery services. The default setting is "Bindery."
- Is there an available NetWare user license for the NIC to use while it acts as a PSERVER? Every PSERVER takes up one user license since it logs in to the Novell file server.
- Have you given the connection process some time after repowering the NIC? In larger Novell environments, the file server identification and connection process can take several minutes.



---

# 12

## *Novell Configuration For 10/100Base-T Interfaces*

---

### Overview

---

This chapter provides additional information for Novell environments using the 10/100Base-T interface, including:

1. **NIC Configuration.** This section includes information about setting the preferred file server; setting password security; adjusting polling time; changing the NIC name; changing the NIC frame type; changing the NIC mode; setting the NIC NDS context; and setting the NIC preferred NDS tree.
2. **Host Configuration.** This section includes information about the NDS PSERVER setup; Bindery PSERVER setup; referencing a Bindery queue in NDS; and RPRINTER/NPRINTER setups.
3. **Troubleshooting tips.** This section covers PSERVER setups, RPRINTER/NPRINTER setups, and printing related problems.

---

### Novell NIC Configuration (10/100Base-T)

---

There are no mandatory Novell settings needed before the print server can be detected on the network. However, there can be some mandatory settings needed before a Novell print queue can be serviced by the NIC. These mandatory settings are covered separately for Netware 3.x, 4.x, and 5.x under the Host Configuration heading.

The print server setup in a Novell environment is much simpler than that required in a TCP/IP one. No addresses, masks, or router entries are necessary, and, in most cases, the NIC can simply be connected to the network, turned on, and then configured for printing from a Novell station through PCONSOLE or Netware Administrator. See Figure 21 for an example of a Novell network which shows the use of file servers and how they relate to the print server.

There are, however, some optional parameters you may wish to change such as the preferred file server(s), print server password, polling time, frame type, print server name, NDS context, and NDS preferred tree. The following sections describe these optional parameters.

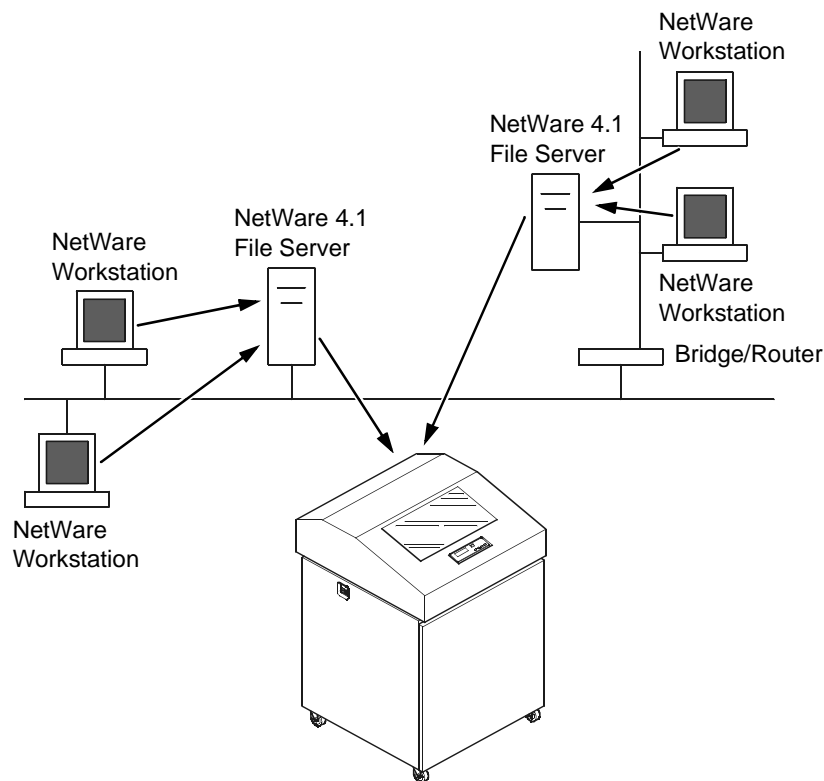

Figure 21. Novell Integration

## Preferred File Server (NDS & Bindery)

In a bindery setup, the preferred file server specifies the file server that the print server object was created on. In an NDS setup, it specifies a file server that the print server object resides on. Since NDS is distributed, most administrators will not know which file server(s) the print server object is actually stored on, so in most NDS environments this option is not used. This feature is useful in a large Novell network so that the NIC does not ignore important file servers. If you are setting up the NIC to work with a Bindery file server, it is a good idea to set a preferred server on the NIC.

To view those file servers that the NIC does acknowledge at a given time, use the `debug nest fserver` command. See Chapter 13, "Commands" for more information.

## Adding Preferred File Server

### HTML Method

1. Load a Web browser on a network station that can communicate with the print server over TCP/IP.
2. Direct your Web browser to URL:  
**`http://P5000LJIPaddress/networkConf.html`**  
(e.g., **`http://192.75.11.9/networkConf.html`**)

---

**Note**

If prompted for a User ID and password first, type in **root** for the ID and press ENTER at the password prompt since there is no password by default.

---

3. Look under the "Novell" section and add the name of the preferred file server in the "File Server" field.
4. Click on the SUBMIT button when done and physically re-power the print server to make the new settings take effect.

### Manual (Telnet) Method

1. Telnet to the print server. This will bring up a login screen:  
**`telnet ipaddress`**

---

**Note**

If prompted for a User ID and password first, type in **root** for the ID and press ENTER at the password prompt since there is no password by default.

---

2. You should now see a prompt displayed that has the NIC's IP address followed by a colon then **root**.  
**`ipaddress:root>`**
3. At the prompt, enter:  
**`store pserver novell fserver add fservername`**  
where **`fservername`** is the name of the Novell file server you want to add as a preferred file server. This adds the specified file server as a preferred file server on the NIC.
4. Reset the unit to ensure the changes take effect.  
**`reset`**

## Removing Preferred File Server

### HTML Method

1. Load a Web browser on a network station that can communicate with the print server over TCP/IP.
2. Direct your Web browser to URL:  
`http://P5000LJIPaddress/networkConf.html`  
(e.g., `http://192.75.11.9/networkConf.html`)

---

#### Note



If prompted for a User ID and password first, type in **root** for the ID and press ENTER at the password prompt since there is no password by default.

---

3. Look under the Novell section and remove the name of the preferred file server from the File Server field.
4. Click on the SUBMIT button when done and physically re-power the print server to make the new settings take effect.

### Manual (Telnet) Method

1. Telnet to the print server. This will bring up a login screen:  
`telnet ipaddress`

---

#### Note



If prompted for a User ID and password first, type in **root** for the ID and press ENTER at the password prompt since there is no password by default.

---

2. You should now see a prompt displayed that has the NIC's IP address followed by a colon then **root**.  
`ipaddress:root>`
3. At the prompt, enter:  
`store pserver novell fserver del fservername`  
where **fservername** is the name of the Novell file server you want to remove as a preferred file server.
4. Reset the unit to ensure the changes take effect.  
`reset`

## Setting Password Security (NDS & Bindery)

---

In addition to the general security measures, a Novell setup provides further password security. A password can be set on the NIC and within your PCONSOLE or Netware Administrator setup so that when the NIC tries to login to the file server, the passwords are compared.

To set the password on the Novell host for use in a PSERVER setup, you will need to complete the steps as follows.

### Netware 4.x and 5.x

1. Log in to NetWare Administrator as a user with security equal to "Admin" on your Novell host.
2. Double click on the print server object you are using for your setup. This will bring up the print server objects details pages.
3. Select the "Change Password..." button on the "Identification" page.
4. At the prompts, type and re-type the new password. Press OK when you are finished.
5. Proceed to the next section to store the password on the NIC.

### Netware 3.x

1. Enter **PCONSOLE** as supervisor on your Novell host.
2. Select "Print Server Information" from the main menu.
3. Select the appropriate printer and press ENTER.
4. Select "Change Password."
5. At the prompts, type and re-type the new password. Press ENTER when you are finished.
6. Proceed to the next section to store the password on the NIC.

### Print Server Setup - HTML Method

1. Load a Web browser on a network station that can communicate with the print server over TCP/IP.
2. Direct your Web browser to URL:  
**http://P5000LJIPaddress/networkConf.html**  
(e.g., **http://192.75.11.9/networkConf.html**)

---

#### Note



If prompted for a User ID and password first, type in **root** for the ID and press ENTER at the password prompt since there is no password by default.

3. Look under the "Novell" section and add the new password to the "Pserver Password" field.

**Note**

The passwords entered in Netware Administrator or PCONSOLE must match the password set on the unit.

---

4. Click the SUBMIT button when done and physically re-power the printer to make the new settings take effect.

### Print Server Setup - Manual (Telnet) Method

1. Telnet to the print server. This will bring up a login screen:

```
telnet ipaddress
```

**Note**

If prompted for a User ID and password first, type in **root** for the ID and press ENTER at the password prompt since there is no password by default.

---

2. You should now see a prompt displayed that has the NIC's IP address followed by a colon then **root**.

```
ipaddress:root>
```

3. At the prompt, enter:

```
store pserver novell passwd password
```

**Note**

The passwords entered in Netware Administrator or PCONSOLE must match the password set on the unit.

---

4. Reset the unit to ensure the changes take effect.

```
reset
```

### Adjusting Polling Time (NDS & Bindery)

---

You can set the poll time the NIC will use when checking for new jobs under a PSERVER setup. To do this, complete the following steps.

#### Netware 4.x and 5.x

1. Log in to NetWare Administrator as a user with security equal to "Admin" on your Novell host.
2. Double click on the printer object for which you wish to change the poll time. This will bring up the printer objects details pages.
3. Click on "Configuration" to display the configuration page.
4. Change the "Service Interval" to the desired number (in seconds).

**Note**

You may also want to change the “Service mode for forms” to “Change forms as needed.” If you do not do this, the NIC will need to poll the file server twice as much to get all the information it needs.

---

5. Re-power the NIC by turning the printer off and on to make the changes take effect.

### Netware 3.x

1. Enter **PCONSOLE** as supervisor on your Novell host.
2. Select “Print Server Information” from the main menu and press ENTER.
3. Select the print server you have been using for your PSERVER setup and press ENTER. By default, this will be **M\_XXXXXX** where **XXXXXX** equals the last six digits of the print server’s Ethernet address found on the bottom of the device (e.g., **M\_091C1A**).
4. Select “Print Server Configuration” from the menu that displays.
5. Select “Printer Configuration” from the next menu to display a list of configured printers.
6. Select the printer for which you wish to alter the poll time and press ENTER.
7. Change the “Sampling Interval” to the desired number (in seconds).

**Note**

You may also want to change the “Service mode for forms” to “Change forms as needed.” If you do not do this, the NIC will need to poll the file server twice as much to get all the information it needs.

---

8. Press ESCAPE and select “Yes” to save the changes to this new printer.
9. Re-power the NIC by turning the printer off and on to make the changes take effect.

## Changing The Print Server Name (NDS & Bindery)

---

When defining a new print queue on a Novell file server, a new print server must be defined to represent the NIC. This name must match the pre-defined name given to the print server. By default, this name is in the format **M\_XXXXXX** where **XXXXXX** equals the last six digits of the NIC’s Ethernet address found on the bottom of the device (e.g., **M\_091C1A**). You must make sure that the print server object that you are using for your PSERVER setup has the same name as that stored on the NIC. If you need to rename the print server object in Netware Administrator, please delete the object and re-create it with the new name. Netware administrator seems to have some problems with renaming objects.

**Note**



Changing the name will effect all of the protocols that are running on the NIC.

---

### HTML Method

1. Load a Web browser on a network station that can communicate with the print server over TCP/IP.
2. Direct your Web browser to URL:  
`http://P5000LJIPaddress/adminConf.html`  
(e.g., `http://192.75.11.9/adminConf.html`)

**Note**



If prompted for a User ID and password first, type in `root` for the ID and press ENTER at the password prompt since there is no password by default.

---

3. Look under the “System Information” section and enter the new name into the “Name” field.
4. Click on the SUBMIT button when done and physically re-power the printer to make the new settings take effect.

### Manual (Telnet) Method

1. Telnet to the print server. This will bring up a login screen:  
`telnet ipaddress`

**Note**



If prompted for a User ID and password first, type in `root` for the ID and press ENTER at the password prompt since there is no password by default.

---

2. You should now see a prompt displayed that has the NIC’s IP address followed by a colon then `root`.  
`ipaddress:root>`
3. At the prompt, enter:  
`store pserver name name`
4. Reset the unit to ensure the changes take effect.  
`reset`



## Changing The Frame Type (NDS & Bindery)

---

The NIC allows the user to store a particular frame type for the unit to adhere to in a Novell environment.

### HTML Method

1. Load a Web browser on a network station that can communicate with the print server over TCP/IP.
2. Direct your Web browser to URL:  
`http://P5000LJIPaddress/networkConf.html`  
(e.g., `http://192.75.11.9/networkConf.html`)

---

#### Note



If prompted for a User ID and password first, type in `root` for the ID and press ENTER at the password prompt since there is no password by default.

---

3. Look under the “Novell” section and go to the “Frame Type” field to select the appropriate frame type.
4. Click on the SUBMIT button when done and physically re-power the printer to make the new settings take effect.

### Manual (Telnet) Method

1. Telnet to the print server. This will bring up a login screen:  
`telnet ipaddress`

---

#### Note



If prompted for a User ID and password first, type in `root` for the ID and press ENTER at the password prompt since there is no password by default.

---

2. You should now see a prompt displayed that has the NIC’s IP address followed by a colon then `root`.  
`ipaddress:root>`
3. At the prompt, enter:  
`store pserver novell frametype [ethernet2 | 802.3 | 802.2 | 802.2snap | autosense]`
4. Reset the unit to make the changes take effect.  
`reset`

## Changing The Print Server Mode (NDS & Bindery)

The NIC allows the user to store a particular mode for the unit to operate in. This will be either NDS, Bindery, or autosense. If autosense is used, the NIC will first attempt to log in to a NDS file server, and, if it fails, it will try to log in to a Bindery file server.

---

**Note**

If you are using both NDS and Bindery file servers in your setup, make sure the mode is set to auto.

---

### HTML Method

1. Load a Web browser on a network station that can communicate with the print server over TCP/IP.
2. Direct your Web browser to URL:  
`http://P5000LJIPaddress/networkConf.html`  
(e.g., `http://192.75.11.9/networkConf.html`)

---

**Note**

If prompted for a User ID and password first, type in `root` for the ID and press ENTER at the password prompt since there is no password by default.

---

3. Look under the “Novell” section and go to the “Service Type” field to select the appropriate mode.
4. Click on the SUBMIT button when done and physically re-power the printer to make the new settings take effect.

### Manual (Telnet) Method

1. Telnet to the print server. This will bring up a login screen:  
`telnet ipaddress`

---

**Note**

If prompted for a User ID and password first, type in `root` for the ID and press ENTER at the password prompt since there is no password by default.

---

2. You should now see a prompt displayed that has the NIC’s IP address followed by a colon then `root`.  
`ipaddress:root>`
3. At the prompt, enter:  
`store pserver novell mode [nds | bindery | auto]`
4. Reset the unit to make the changes take effect.  
`reset`

## Setting The NIC Context (NDS)

The NIC allows you to store the print server object in any context within the NDS tree you choose. By default, the NIC will look for the print server object in the same context as the file server object it connects to is stored in.

### HTML Method

1. Load a Web browser on a network station that can communicate with the print server over TCP/IP.
2. Direct your Web browser to URL:  
`http://P5000LJIPaddress/networkConf.html`  
 (e.g., `http://192.75.11.9/networkConf.html`)

#### Note



If prompted for a User ID and password first, type in **root** for the ID and press ENTER at the password prompt since there is no password by default.

3. Look under the "Novell" section and enter the new context in the "NDS Context" field.
4. Click on the SUBMIT button when done and physically re-power the printer to make the new settings take effect.

### Manual (Telnet) Method

1. Telnet to the print server. This will bring up a login screen:  
`telnet ipaddress`

#### Note



If prompted for a User ID and password first, type in **root** for the ID and press ENTER at the password prompt since there is no password by default.

2. You should now see a prompt displayed that has the NIC's IP address followed by a colon then **root**.  
`ipaddress:root>`
3. At the prompt, enter:  
`store pserver novell context context`
4. Reset the unit to make the changes take effect.  
`reset`

## Setting The Print Server Preferred NDS Tree (NDS)

The NIC supports Novell environments that have multiple trees. If your environment has more than one tree, you may want to set a preferred tree. By default, the NIC will try to log in to each tree it finds until it is successful.

### HTML Method

1. Load a Web browser on a network station that can communicate with the print server over TCP/IP.
2. Direct your Web browser to URL:  
`http://P5000LJIPaddress/networkConf.html`  
(e.g., `http://192.75.11.9/networkConf.html`)

---

**Note**

If prompted for a User ID and password first, type in **root** for the ID and press ENTER at the password prompt since there is no password by default.

3. Look under the “Novell” section and enter the preferred tree in the “NDS Preferred Tree” field.
4. Click on the SUBMIT button when done and physically re-power the printer to make the new settings take effect.

### Manual (Telnet) Method

1. Telnet to the print server. This will bring up a login screen:  
`telnet ipaddress`

---

**Note**

If prompted for a User ID and password first, type in **root** for the ID and press ENTER at the password prompt since there is no password by default.

2. You should now see a prompt displayed that has the NIC’s IP address followed by a colon then **root**.  
`ipaddress:root>`
3. At the prompt, enter:  
`store pserver novell tree tree`
4. Reset the unit to make the changes take effect.  
`reset`

---

## Novell Host Configuration (10/100Base-T)

---

This section covers PSERVER and RPRINTER/NPRINTER setups on the NIC. The NIC can handle up to eight RPRINTER/NPPRINTER setups.

Although the entire print setup is done through Netware Administrator or PCONSOLE, you may need to communicate directly with the print server in order to modify settings, monitor the unit, etc.

For Netware 4.x environments, you can obtain a NWAdmn3x snap-in program called MPAdmin. This snap-in can be used to configure PSERVER setups as well as additional settings on the NIC.

---

**Note**

NWAdmn3x is only included with Netware 4.11 and higher releases. If you are using Netware 4.10, you can either upgrade to Netware 4.11 or go to Novell's web site and get the patches to upgrade the Nwadmin program for Netware 4.10 to Nwadm3x for Netware 4.11. Alternatively, you can perform the setup without using MPAdmin.

---

## NDS PSERVER Setup (Netware 4.x and 5.x)

---

There are a number of ways to configure the NIC for use in a Novell NDS PSERVER setup. These include using the MPAdmin snap-in for Netware Administrator, using generic print server objects in Netware Administrator, or by using PCONSOLE. The following steps describe a setup using generic print server object in Netware Administrator. Setups using PCONSOLE are less common and will not be discussed.

To create a printer/print queue in an NDS environment using Netware Administrator print server objects, you need to complete the following steps:

1. Log in to NetWare Administrator as a user with security equal to "Admin" on your Novell host.
2. Click with the right mouse button on a branch in the tree that you would like to create a print queue object in.
3. Select "Create..." from the menu that pops up to bring up the "New Object" dialogue.
4. Select "Print Queue" from the "Class of new object" list, and then click "OK."
5. Select "Directory Service Queue," and type the name of the queue in the "Print Queue name" field.
6. Fill in the "Print Queue Volume" field by typing in a volume or browsing for one. Click "Create" when you are done.
7. Click with the right mouse button on a branch in the tree that you would like to create a printer object in.
8. Select "Create..." from the menu that pops up to bring up the "New Object" dialogue.
9. Select "Printer" from the "Class of new object" list, and then click "OK."

10. Type in the name for the printer in the “Printer name” field.



**Note** The Printer object name must match one of the destination names on the NIC. Most likely, this will be d1prn.

---

In NDS, a printer object can only be attached to one print server object at a time, as Novell is using the printer object to represent a physical printer. A physical printer can only be attached to one parallel or serial port at a time. Thus, if you assign a printer object to another print server object, the new print server object will “steal” it from the old one (this also happens with non-NIC print server objects).

To properly process print jobs sent to the NIC, the printer object created in Novell must refer to the destination on this server and not to the actual physical printer. On the NIC, print jobs must pass through an extra layer (a “destination”) before being sent on to the printer. This destination allows for further processing of the print job before sending it to the printer.

If you are using multiple print servers, you will have to either rename all your destinations to ensure that no printer object names conflict or keep all the printer objects for one print server in a different context than those for the other print server.

11. Select “Define additional properties” and click “Create.”
12. Click “Assignments” in the dialogue that pops up, and then click the “Add...” button.
13. Select the queue you defined earlier, or browse for a different one.
14. Click “OK” to assign this queue to this printer.
15. Click “OK” to close the Printers details dialogue and make the changes permanent.
16. Click a branch in the tree (i.e., context) that you would like to create the NIC print server object in.



**Note** If the context you choose is different than the one the file server object for the file server you are using is in, you must set the context on the NIC. See “Setting The NIC Context (NDS)” on page 227.

---

17. Click with the right mouse button to bring up a submenu, and choose “Create...” from this menu. A dialog titled “New Object” pops up.
18. Select “Print Server” in the “Class of new object” list, click “OK.”
19. Type in the name for the print server in the “Print Server name” field. By default, the name is M\_XXXXXXX where XXXXXX equals the last six digits of the print server’s Ethernet address found on the bottom of the device (e.g., M\_091C1A).

**Note**

The name you use here must match the name stored on the NIC. This name can be found by using the `list pserver` command. See “List Commands” on page 254 for more information.

---

20. Select the “Define additional properties” and click the “Create” button.
21. Click “Assignments” in the dialogue that pops up, and then click the “Add...” button.
22. Select the printer you created earlier.
23. Click “OK” to assign this printer to this print server.
24. Click “OK” to close the printer servers details dialogue and make the changes permanent.
25. Physically re-power the printer to make the new settings take effect.

### Bindery PSERVER Setup (Netware 3.x, 4.x, and 5.x)

---

A Bindery PSERVER setup is possible under Netware 3.x, Netware 4.x and Netware 5.x. If you are using Netware 4.x or 5.x, Bindery emulation is required. Please consult your Novell manual on how to set up Bindery emulation. A Bindery setup using PCONSOLE in Netware 3.x is described in “NetWare Version 3.x RPRINTER Setup” on page 210. The setup using PCONSOLE in Netware 4.x is described in “NetWare Version 4.x and 5.x RPRINTER Setup” on page 213.

### Referencing A Bindery Queue In NDS (Netware 3.x, 4.x, and 5.x)

---

To reference a Bindery queue when you perform your PSERVER setup in NDS, you create a PSERVER object for the NIC on the file server where the Bindery queue resides. This is important because to service the queue, the NIC must log on to the queue’s file server. Since the queue is not an NDS queue, the NIC cannot log in under NDS, so it must log in under Bindery.

This only works if there is a valid PSERVER object on the file server. This PSERVER object must have the same name that was used for the NDS setup. By default, this will be “M\_XXXXXX” where “XXXXXX” equals the last six digits of the print server’s Ethernet address found on the bottom of the device (e.g., M\_091C1A). This PSERVER object does not need to have any printers or queues assigned to it. Also, when referencing a Bindery queue in NDS, the Novell Mode on the NIC must be set to “auto” so that both NDS and Bindery logins are possible. See “Setting The NIC Context (NDS)” on page 227.

## RPRINTER/NPRINTER Setup (Netware 3.x, 4.x, and 5.x)

This procedure associates an existing PSERVER with a remote NIC acting as a RPRINTER/NPRINTER in a NetWare 3.x or Netware 4.x or Netware 5.x environment. It is the PSERVER's responsibility to get jobs from the queue and to pass them off to the NIC acting as the remote printer. Unlike a PSERVER setup, the NIC does not deal directly with the queues.

---

**Note**

As an RPRINTER/NPRINTER, the print server does not use a login ID. A non-NIC print server such as PSERVER.NLM or PSERVER.EXE must be running for RPRINTER to operate. Also, if the NIC loses a connection to a PSERVER, it will automatically reconnect when that server becomes available again.

---

The following steps assume that you have created a PSERVER object in either Netware 3.x or Netware 4.x or Netware 5.x and have assigned printers and queues to it. If you have not already done this, do it now. The setup is similar to creating a PSERVER setup for the NIC, except that there are no restrictions about which names you may use for the print server and printer objects.

---

**Note**

Write down the printer number(s) assigned to the printer(s) you are going to use for this setup. You will need them in a later step.

---

### HTML Method

1. Load a PSERVER on your Netware 3.x or Netware 4.x or Netware 5.x file server (i.e., issue a `load pserver pservername` command on the file server).

---

**Note**

If it is an NDS PSERVER on a Netware 4.x or 5.x file server, you must specify the PSERVER name and context for `pservername`. For example:  
`load pserver .sales_ps.sales.hp`

2. Load a Web browser on a network station that can communicate with the print server over TCP/IP.
3. Direct your Web browser to URL:  
`http://P5000LJIPaddress/networkConf.html`  
(e.g., `http://192.75.11.9/networkConf.html`)

---

**Note**

If prompted for a User ID and password first, type in `root` for the ID and press ENTER at the password prompt since there is no password by default.



4. Look under the "Novell" section and find a row in the RPRINTER category.
5. Click "Enabled" and enter the name used with the PSERVER.NLM started in step 1 into the "Print Server Name" field.

---

**Note**



If it is an NDS pserver, only enter the PSERVER name and not the context (e.g., `sales_ps`).

---

6. Enter the printer number of the printer you would like serviced into the "Printer Number" field, and then select the destination on the NIC you would like to use for output.
7. Repeat steps 4 through 6 for each additional printer you would like to have serviced.
8. Click the SUBMIT button when done and physically re-power the printer to make the new settings take effect.

### Manual (Telnet) Method

1. Load a PSERVER on your Netware 3.x or Netware 4.x or Netware 5.x file server (i.e., issue a `load pserver pservername` command on the file server).

---

**Note**



If it is an NDS PSERVER on a Netware 4.x or 5.x file server, you must specify the pserver name and context for `pservername`. For example:  
`load pserver .sales_ps.sales.hp`

---

2. Telnet to the print server. This will bring up a login screen:  
`telnet ipaddress`

---

**Note**



If prompted for a User ID and password first, type in `root` for the ID and press ENTER at the password prompt since there is no password by default.

---

3. You should now see a prompt display that has the NIC's IP address followed by a colon then `root`.  
`ipaddress:root>`
4. At the prompt, store the RPRINTER settings on the NIC. The `pservername` refers to the existing PSERVER.NLM on the file server created in step 1.

Syntax:

```
store rprinter add pservername printernumber
P5000LJdestination
```

Example for an RPRINTER servicing printer 0 of the PSERVER.NLM called `pserver1` and sending jobs to the NIC destination `d1prn`:  
`store rprinter add pserver1 0 d1prn`



**Note** If it is an NDS pserver, only enter the PSERVER name and not the context (e.g., `sales_ps`).

---

5. Physically re-power the printer to make the new settings take effect.

Wait two minutes and then check your PSERVER to see if the appropriate printer is being serviced. The printer should display a message such as "Waiting for job." At this point, the NIC knows to receive any jobs this PSERVER.NLM has to send to it through the defined printer.

---

## NPDS Configuration (Netware 4.11 and Above)

---

### Overview

In 1998, Novell released a new printing system designed to make network administration of printers easier and more fully functional. This system is called Novell Distributed Print Services (NDPS), and can be used with Novell Netware 4.11 and above along with the supporting software on clients. This section gives high-level instructions to install and use NDPS with the printer. These instructions assume that you understand NDPS architecture well enough to be able to use these instructions along with Novell's instructions to install the NIC into NDPS. See Novell's documentation to better understand terms not defined here.

The drivers used with the P5000LJ printer can be automatically downloaded into a Windows machine when a NDPS printer is installed, if the driver is installed into the NDPS Broker Resource Management Service. See Novell's documentation for more information.

The NIC can be installed into NDPS using the Novell Printer Gateway feature of NDPS. Within this Novell Printer Gateway, use the following various printer connection modes to install the printer into NDPS:

- setup using Forward Jobs to a Queue Mode
- setup using LPR Mode
- setup using PPRINTER Mode

## Setup using Forward Jobs to a Queue Mode

In this mode, an NDPS printer agent receives jobs from an NDPS client, then forwards these jobs to an existing Netware queue. The Netware queue would then be serviced by the NIC in some manner.

1. The P5000LJ printer must first be set up to service some Netware queue, either by doing a PSERVER or RPRINTER mode setup from previous chapters.
2. When setting up the NDPS printer agent, use the "Novell Printer Gateway."
3. For the "Novell PDS," choose "((NONE))."
4. For the "Port Handler," choose "Froward Jobs to a Queue," then choose the queue used in step 1 above, and note the Caution statement about the Queue User Name.
5. For the "Select Printer Drivers" dialog, choose no driver unless you have a driver into the Broker's RMS which is to be used with the P5000LJ printer.

## Setup using LPR Mode

In this mode, an NDPS printer agent receives jobs from an NDPS client, then forwards these jobs to a printer using the LPR protocol.

1. The NIC must first be set up with IP connectivity and be able to receive jobs using the LPR protocol.
2. When setting up the NDPS printer agent, use the "Novell Printer Gateway."
3. For the "Novell PDS," choose "((NONE))."
4. For the "Port Handler," choose "Remote (LPR on IP)," then enter the hostname/ipaddress and printer name (d1prn - d4prn by default) in the next dialog.

**NOTE:** When the IPDS feature is installed, queue name d4prn is not available.

5. For the "Select Printer Drivers" dialog, choose no driver unless you have a driver installed into the Broker's RMS which is to be used with the P5000LJ printer.

## Setup Using RPRINTER Mode

In this mode, an NDPS printer agent receives jobs from an NDPS client, then forwards these jobs to a printer using the RPRINTER IPX protocol.

1. The NIC must first be set up to function in RPRINTER mode, choosing any desired Print Server Name and Printer Number.
2. When setting up the NDPS printer agent, use the "Novell Printer Gateway."
3. For the "Novell PDS," choose "((NONE))."
4. For the "Port Handler," choose "Remote (rprinter on IPX)."

5. In the next dialog, for the “SAP Name” enter the Print Server Name from step 1, and enter the Printer Number from step 1 above.
6. For the “Select Printer Drivers” dialog, choose no driver unless you have a driver installed into the Broker’s RMS which is to be used with the P5000LJ printer.

The P5000LJ printer will need to be rebooted to attach to the NDPS printer agent in this mode.

## Troubleshooting (10/100Base-T)

---

### PSERVER Setup

---

If there is no connection with the NIC after you have completed the print setup, there are several things to confirm.

---

**Note**

The debug information that is mentioned in this section can be found by either telneting to the NIC and issuing the commands given, or by launching a browser to the Novell status page on the NIC  
(e.g., <http://192.168.11.9/networkNovellStatus.html>).

---

- Have you tried repowering the NIC? Wait about a minute before checking to see if it has logged in and attached to a queue.
- Is the network connector fastened tightly to the unit?
- Is the NIC already servicing a queue on another file server? If so, it cannot service another file server at the same time.
- Is there an available NetWare user license for the NIC to utilize while it acts as a PSERVER? Every PSERVER takes up one user license since it logs in to the Novell file server.
- When going through the PSERVER setup steps, did you name the NIC “M\_XXXXXX” where “XXXXXX” equals the last six digits of the Ethernet address? This is the default format of the unit’s name when it is acting as a PSERVER.

---

**Note**

This “M\_XXXXXX” name must have six digits after the “\_”, so if necessary, pad out each byte with a zero (0).

---

- Has the NIC’s name been changed from its default of “M\_XXXXXX”, and, if so, have you incorporated this new name into your PSERVER setup?
- Is there a password set for the Print Server to utilize when it is logging in to the file server? Make sure the NIC’s PSERVER password matches that of the PSERVER setup or set both places to no password.

- When setting the NIC up as a PSERVER, did you specify a destination on the NIC (e.g., d1prn) for the printer name, and did you remember this name is case sensitive?

---

**Note**

NIC destinations are case sensitive so they will not be recognized if they are typed incorrectly. By default, they are all in lowercase. If you are setting up in a NetWare 4.x environment, the destination must be renamed to uppercase to match the PCONSOLE or Netware Administrator entry. Please see **set dest destination name newname** on page 247 for information on changing names.

---

- Does the destination you used in your PSERVER setup have the Novell service enabled? See Chapter 13, “Commands” for information on enabling/disabling services.
- Try doing a **debug nest ipx** telnet command on the NIC (or find the “IPX Layer” section on the Novell HTML status page). Check that a board has been bound to the NIC and that the network number is correct for your network. If not, you may want to set a specific frame type for the NIC to use. You can find out what frame type is bound to which board number using the **debug nest odi** command (or from the “ODI Layer” section on the Novell HTML status page).
- Try a **debug nest fserver** telnet command (or find the “File Servers” section on the Novell HTML status page). If no file servers show up, then there is probably a problem with the network connection, or the NIC is not on a Novell network. Try a **debug nest sap** telnet command (or find the “SAP” section on the Novell HTML status page) to see if the NIC is seeing any network activity.
- Try a **debug nest pserver** telnet command (or find the “PSERVER” section on the Novell HTML status page). Look for a valid queue under the “EPS QUEUES” section. If the printer field contains a number and there is a valid file server but no queue, then you probably made an error in the setup and should try again. If it is an NDS PSERVER setup, look for a line with the following type of message “Could not login to NDS Tree <TREE> as <PSERVER.<CONTEXT>.” This means that either the tree is wrong; the context stored on the NIC for the print server object is wrong; the print server object password is wrong; or the print server object name is wrong.

- Try a **debug nest rprinter** telnet command (or find the “RPRINTER” section on the Novell HTML status page). Look for the following type of line: “(0:ENPReadConfig):[0:213] Destination = <X>,” where <X> is between 0 and 3. If they all say “Destination = 65536,” then the PSERVER setup did not complete properly. If there was a valid queue under “EPS QUEUES” in the **debug nest pserver** command, then the printer name probably doesn’t match an existing destination name on the NIC, or Novell has been disabled for that destination. If there is a valid “Destination =” line, then double check that there is an entry for this number under the “ENP INFO” section.

---

**Note**

Debug messages for the PSERVER setup are in the RPRINTER section here because the PSERVER setup on the NIC shares some code with the RPRINTER setup.

---

- Try a **debug nest logs** telnet command (or find the “General Messages” section on the Novell HTML status page). Look for a valid entry for the printer. It will look something like this: “(0:InitSinglePrinter): printer=<X> name=<NAME>.” Then look for the following lines: “(0:Printf): RemoteMonitor(<X>); printer is” and “(0:Printf): WAITING\_FOR\_JOB.” If you see these lines, the NIC is setup properly and the problem points to a setup issue on the workstation.
- If the NIC has logged in to the file server but has not attached to the queue, there may be a permission problem. Make sure the appropriate users have rights to this queue (they should be in the group “everyone”). Also, you may have to assign the queue to **root** so it is available to everyone.
- Did you rename any objects in Netware Administrator during your setup? Netware Administrator seems to have problems renaming objects. If so, delete everything and start over.

If none of these solutions help your situation, you may want to try the whole setup again. Completely delete the setup that is giving you trouble and go through the setup again following each step carefully.

---

**Note**

Be sure to reboot the printer before beginning a new setup and after completing a PSERVER setup. Wait at least a minute for the Print Server to log in and attach to a queue.

---

---

## RPRINTER/NPRINTER Setup

---

If there is no connection with the NIC after you have completed the print setup, there are several things to confirm.

---

**Note**

The debug information that is mentioned in the section can be found by either telneting to the NIC and issuing the commands given, or launching a browser to the Novell status page on the NIC.

(e.g., <http://192.168.11.9/networkNovellStatus.html>)

---

- Have you tried repowering the printer? Wait about a minute before checking to see if it has logged in and attached to a queue.
- Is the network connector fastened tightly to the unit?
- Is the NIC already servicing a queue on another file server? If so, it cannot service another file server at the same time.
- Is there an entry when a **list rprinter** telnet command is done on the NIC (not found on the Novell HTML status page)? When the NIC is configured as an RPRINTER, this command should produce the appropriate entry.
- If the NIC has logged in to the file server but has not attached to the queue, there may be a permission problem. Make sure the appropriate users have rights to this queue (they should be in the group “everyone”). Also, you may have to assign the queue to **root** so it is available to everyone.
- Does the destination you used in your RPRINTER setup have the Novell service enabled? Please see Chapter 13, “Commands” for information on enabling/disabling services.
- Try doing a **debug nest ipx** telnet command on the NIC (or find the “IPX Layer” section on the Novell HTML status page). Check that a board has been bound to the NIC and that the network number is correct for your network. If not, you may want to set a specific frame type for the NIC to use. See “Changing The Frame Type (NDS & Bindery)” on page 225. You can find out what frame type is bound to which board number using the **debug nest odi** command (or from the “ODI Layer” section on the Novell HTML status page).
- Try a **debug nest sap** telnet command (or find the “SAP” section on the Novell HTML status page) to see if the NIC is seeing any network activity.
- Try a **debug nest rprinter** telnet command (or find the “RPRINTER” section on the Novell HTML status page). Look for an entry for one of the numbers 4 to 7 under “ENP INFO.” The “dest” field should match the destination used on the NIC. If no entry is found, check that the destination has the Novell service enabled. If the “ERROR-CODE” field has an error of 308, make sure no other RPRINTER setup is servicing this printer object at the same time. Only one RPRINTER connection is allowed to service a PSERVER.NLM printer.

- If the NIC has logged in to the file server but has not attached to the queue, there may be a permission problem. Make sure the appropriate users have rights to this queue (they should be in the group “everyone”). Also, you may have to assign the queue to `root` so it is available to everyone.

If none of these solutions help your situation, you may want to try the whole setup again. Completely delete the setup that is giving you trouble and go through the setup again following each step carefully.

---

**Note**

Be sure to reboot the printer before beginning a new setup and after completing an RPRINTER setup. Wait at least a minute for the Print Server to login and attach to a queue.

---

## Printing Related

---

### The job goes to the queue but nothing prints

If nothing is printing, make sure you have a connection to the NIC first. See the PSERVER or RPRINTER sections above if you are having connection-related problems. Otherwise, consider these points when trying to solve printing problems in a Novell environment:

- Does the job leave the queue, or is it stuck there indefinitely? If it leaves properly, the problem points to the actual printing mechanism on your Novell system (e.g., CAPTURE, NPRINT, etc.); to the print job format; or to the printer itself. Otherwise, review the configuration steps you have already followed.
- Have you confirmed that you can print from the NIC to the printer ignoring the Novell setup altogether? Please see `start fox|tts|loopb prn` on page 256 for a good test.
- Is anything happening on the printer when the print job is sent? Sometimes, the print job may have arrived at the printer but can be waiting for a manual form feed. If this is the case, please see “Set Commands” on page 247 for information on trailer strings.
- Is the printing mechanism you are using (e.g., CAPTURE, NPRINT, etc.) configured to service the appropriate queue?
- Is the NIC configured as the queue’s “Currently Attached Server”? If not, make sure you have associated the queue and the printer. See “Novell Host Configuration” on page 208.
- Is there a hold on the print job? If you select the job from PCONSOLE’s CURRENT PRINT JOB ENTRIES, change the User Hold or Operator Hold to “No.”
- If you look in PCONSOLE’s CURRENT QUEUE STATUS within the PRINT QUEUE INFORMATION menu, is the server configured to service entries in this queue? It is possible to turn servicing off here.



If you have followed the suggestions above and are still having printing problems, try rebooting the NIC. Then either review every step you took when configuring the NIC, or try re-doing the setup, paying special attention to each step explained in "Novell Host Configuration" on page 208.

### **The job prints incorrectly**

This category can be broken down into several sub-categories such as lost characters, garbled data, extra banner pages, or blank pages at the end of the job. However, the reason for these mishaps can generally be traced to the printing mechanism used on your Novell system. These points should be considered when configuring your print method (e.g., CAPTURE, NPRINT, etc.):

- Did you include the "No Tabs" option?
- Did you specify "No Banner" with PostScript printers?
- Did you turn off banner pages and form feeds if this is already taken care of within an application or on the NIC? Doubling up of these types of print features is easy to do since these options are provided both on the NIC (in a model) and within the print command.
- Are you running the latest version of PSERVER (later than 1.22)? If not, upgrade the PSERVER software.
- In a PSERVER setup, did you ensure that the printer name (e.g., d1prn) was set up as "Defined Elsewhere"?
- Is the timeout option in the CAPTURE command set high enough so the printer does not time out before the print processing has had a chance to complete? This can be a problem with graphic jobs.

Some other things to consider when garbled data persists are:

- tab expansion (**x~~t~~ab**) set on (in a model) with graphic jobs
- the correct driver for the printer if printing from within Windows

For additional information on these suggestions or on various Novell printing mechanisms, please refer to your *NetWare User Manuals*.



---

# 13

# Commands

---

## Command Shell Overview

---

The NIC comes with an in-depth command shell which allows you to manipulate objects like destinations, I/O ports, and models. Additionally, it provides you with monitoring and troubleshooting capabilities.

### Access Methods

---

There are many ways this command shell can be accessed:

- built-in HTML forms
- a Telnet session from a TCP/IP host to the NIC
- a single remote shell command (i.e., rsh, rcmd, remsh) from a TCP/IP host

### Main Command Shell Prefixes

---

All configurable commands start with either **store** or **set**. Troubleshooting commands usually start with **debug**, and view commands start with **list**.

If the **store** prefix is used, the NIC must be repowered for the changes to take effect. Since **store** affects flash memory settings only, the print server must reset and read the new settings now in flash memory.

If the **set** prefix is used, a **save** command must also be executed so that the new settings are retained after power cycles. Since **set** only affects the settings in memory, they will be lost after a power cycle unless they are saved to flash memory.

### Getting Command Help

---

The NIC command shell provides several online help tools. These include the following:

#### ? Command

Typing ? when logged in to the command shell will produce a full listing of all commands available.

## Command Prefixes

Typing in the first portion of a command will produce an error message showing the correct syntax. For example, typing in `store tcpip` will produce a list of all commands that start with this prefix.

## Complete Command List

This section outlines the entire NIC command set including the command syntax, a description, and, in most cases, an example for each command listed.

### Note



If you see the word *ifnum* in any shell commands, you should substitute a 1 unless directed to do otherwise. This 1 represents the one network interface (i.e., Ethernet) supported.

## Store Commands

These commands change the settings stored in flash memory and do not affect the current or working settings in memory. A power cycle is needed before the stored settings become current.

```
store ifc ifnum utp [-]li [-]rx
```

```
store ifc 1 utp li
```

Modify the physical UTP interface properties where `li` enables link integrity and `rx` enables the increased receive threshold.

```
store ifc from default
```

Set all UTP settings back to factory defaults.

```
store ifc from current
```

Store all current UTP settings to flash memory so they are retained after a power cycle. This ensures all current settings match what is stored in flash memory.

```
store pserver opts [[-]jobsecurity] [jobtimeout seconds]
```

```
store pserver opts jobsecurity jobtimeout 5
```

If `jobsecurity` is disabled, any user can cancel queued jobs on the NIC including guest users. If `jobtimeout` is set to some value other than 0, the NIC will only wait this amount of *seconds* when getting printer feedback. This is only used if you have a logpath port and type set on a particular destination.

```
store pserver tcpsocket TCPportnumber port newTCPportnumber
```

```
store pserver tcpsocket 4000 port 5000
```

Change a pre-defined *TCPportnumber* on the NIC to a *newTCPportnumber*. The default number is 9100 for prn.

```
store pserver tcpsocket TCPportnumber dest destination
store pserver tcpsocket 5000 dest dlprn
```

Assign a pre-defined *TCPportnumber* to a particular *destination* on the NIC. Therefore, if you are using a print method that sends jobs directly to a TCP port number, you still have the option to process the job data through this destination setting.

```
store pserver novell passwd password
store pserver novell passwd mplex
```

Store the *password* for the NIC to use when logging in to a Novell file server. This *password* would have to match one set on the file server.

```
store pserver novell user name username
store pserver novell user name microl
```

Define a *username* on the NIC to be used when it logs in to a Novell file server to find information. This *username* must match a user pre-defined on the Novell file server.

```
store pserver novell user passwd password
store pserver novell user passwd mplex2
```

Define a *password* on the NIC for the Novell user already defined. This *password* must match the one stored on the Novell file server. Passwords are optional as long as there is not one defined on the file server for the user.

```
store pserver novell fserver add|del fileservername
store pserver novell fserver add fs1
```

Add or remove a server entry on the NIC for the Novell file server it will be servicing.

```
store pserver smb workgrp newworkgroupname
store pserver smb workgrp eng
```

Define a different Windows workgroup as defined by *newworkgroupname* for the NIC to be visible within. By default, the print server only comes up within the group called "WORKGROUP."

```
store pserver from default
```

Set all general print server settings back to factory defaults.

```
store pserver from current
```

Store all current general print server settings to flash memory so they are retained after a power cycle. This ensures all current settings match what is stored in flash memory.

```
store rprinter add|del printservername printernumber
destination
```

```
store rprinter add pserver1 0 dlprn
```

Add or delete the RPRINTER settings on the NIC for a Novell environment. The *printservername* must be the name of an existing PSERVER.NLM on your Novell file server. The *printernumber* is the printer number within this PSERVER.NLM. The *destination* is the queue on the NIC where the print jobs will be sent to.

```
store tcpip ifnum addr IPaddress
store tcpip 1 addr 192.75.11.9
```

Store the IP address for the NIC.

```
store tcpip ifnum mask netmask
store tcpip 1 mask 255.255.255.0
```

Store the subnet mask for the NIC.

```
store tcpip ifnum opts [[-]rarp] [[-]bootp] [[-]dhcp]
store tcpip 1 opts -rarp -bootp -dhcp
```

Enable or disable the automatic RARP, BOOTP, or DHCP requests for IP addresses upon bootup. If you are storing the NIC TCP/IP network settings within the device, you will not need to rely on RARP, BOOTP, or DHCP for new settings.

```
store tcpip ifnum frametype [[-]ethernet2]
[[-]802.2snap]
store tcpip 1 frametype ethernet2 802.2snap
```

Control which frame type(s) is supported with the TCP/IP protocol. By default, both **ethernet2** and **802.2snap** are enabled but normal TCP/IP communications rely on Ethernet 2. This setting has no effect on other supported network protocols (e.g., Novell).

```
store tcpip route add|del host|net IPaddress ifnum
store tcpip route add net 192.75.12.0 1
store tcpip route del net 192.75.12.9 1
```

Add or delete a static route to a particular TCP/IP host or subnet specified by **IPaddress** so the NIC knows how to communicate with it. Normally one entry for a default router/gateway is all that is needed for communications between different subnets. Please see the next command for details.

```
store tcpip route add|del default routerIPaddress
ifnum
store tcpip route add default 192.75.11.1 1
```

Store a default router/gateway defined by **routerIPaddress** so the NIC knows where to direct packets destined for another subnet. It is easier to store one default entry rather than an entry per remote host or network as in the previous command.

```
store tcpip tcp rxwin packets
store tcpip tcp rxwin 2
```

Determine the receive window size for the NIC. Usually the **packets** value ranges from 2 to 8 with the lower number allowing for more simultaneous TCP connections with the print server.

```
store tcpip tcp opts [-]keepalive [-]disbufmgmt
store tcpip tcp opts keepalive -disbufmgmt
```

Control whether the NIC maintains a connection with a host when data cannot be accepted into its buffer. Normally the **keepalive** feature is enabled so when the printer can not accept data, the print job connection is maintained and continued once the situation clears. If **disbufmgmt** is disabled (i.e., "-"), the NIC will not buffer any data when there is a blocked situation with the printer. Normally it is best to have both **keepalive** and **disbufmgmt** enabled.

```
store tcpip tcp access [root] add|del IPaddress
```

```
store tcpip tcp access add 192.75.11.25
```

Add or remove an entry from the NIC TCP access list defined by *IPaddress*. If the list has an entry, only this host can print to and remotely interact with the print server.

```
store tcpip from default
```

Set all TCP/IP network settings back to factory defaults.

```
store tcpip from current
```

Store all current TCP/IP network settings to flash memory so they are retained after a power cycle. This ensures all current settings match what is stored in flash memory.

## Set Commands

---

These settings alter the current or working settings in memory only. Therefore, they will be lost if the NIC is power cycled. To ensure this does not happen, be sure to issue a **save** command so the current settings get written to flash memory.

```
set date year month day
```

```
set date 1997 02 10
```

Set the current date noting the four-digit *year*, the two-digit *month* from 01 through 12, and the *day* being the number in the month. If the NIC is reset, this value will be lost so you will need to set the date again.

```
set dest destination name newname
```

```
set dest dlprn name laser
```

Change the current name of the *destination* to a new name as indicated by *newname*. This *newname* must be nine characters or less or it will be truncated. These names are case sensitive.

```
set dest destination backchannel prn [prn]
```

```
set dest dlprn backchannel prn
```

Establish a return path for printer feedback for a given *destination*. Since the NIC I/O port is bi-directional, however, you will most likely use the same I/O port that the *destination* is currently sending jobs to.

```
set dest destination model modelname
```

```
set dest dlprn model m4
```

Associate a model with a destination. Jobs sent to the named *destination* are processed according to the options defined in the named model.

```
set dest destination logpath logpathname
```

```
set dest dlprn logpath l4
```

Associate a logpath with a destination. Jobs sent to the named *destination* are logged according to the settings defined in the named logpath.

```
set dest destination service [[-]socket][[-]lpd]
[[-]lpsched] [[-]rprinter] [[-]pserver] [[-]netbios]
[[-]ftpd]
```

```
set dest dlprn service -netbios
```

Set the *destination* to handle only certain print services. To add a service, specify the service name. To disable a service, use “-” before the name. The available services are:

- socket** Direct socket printing via TCP/IP.
- lpd** LPR printing with TCP/IP including LPR clients on any platform.
- lpsched** LP or System V printing with TCP/IP.
- rprinter** Novell RPRINTER support.
- pserver** Novell PSERVER support.
- netbios** Windows 95 and Windows for Workgroups printing.
- ftpd** Printing using the File Transfer Protocol (ftp) via TCP/IP.

**set dest from default**

Set all destination settings back to factory defaults.

**set dest from stored**

Set all current destination settings to the values stored in flash memory.

**set logpath logpath name newname**

**set logpath l1 name pagecount**

Change the current name of the *logpath* to a new name as indicated by *newname*. This *newname* must be nine characters or less or it will be truncated. These names are case sensitive.

**set logpath logpath type [[-]job] [[-]user] [[-]pgcnt] [[-]cksum] [[-]printer] [[-]ioport]**

**set logpath l2 type job user printer pgcnt**

Establish the type of printer and print job logging to be done within this *logpath*. The options are:

- job** Job ID, username, etc.
- user** User ID along with three messages per job about start and finish.
- pgcnt** For total pages printed in a job.
- cksum** 16-bit checksum value to confirm integrity of data printed.
- printer** For special printer feedback.
- ioport** Printer error messages determined through the parallel port pins.



```
set logpath logpath port TCPportnumber | email | syslog
set logpath 13 port 2000
```

Determine where the log information should be sent for a print job or attached printer. The choices are:

***TCPportnumber*** TCP port number ranging from 1024 to 65000.

**email** Particular user's email address. This address is set using the **set sysinfo email *emailname@IPaddress*** command.

**syslog** A central TCP/IP host running the SYSLOG daemon. This host is set using the **set sysinfo syslog *IPaddress*** command.

```
set logpath from default
```

Set all logpath settings back to factory defaults.

```
set logpath from stored
```

Set all current logpath settings to the values stored in flash memory.

```
set model model name newname
```

```
set model m1 name landscape
```

Change the current name of the *model* to a new name as indicated by *newname*. This *newname* must be nine characters or less or it will be truncated. These names are case sensitive.

```
set model model type raw
```

```
set model m2 type raw
```

Set the model *type* to *raw* so that it does not process the data passing through it in any way.

```
set model model banner [ps|text|auto [after]]
```

```
set model m2 banner text
```

Determine whether a banner page should be added for print jobs passing through the *model* mapped destination/queue. *auto* will determine which type is needed depending on the type of print job data passing through. By default, banner pages are added to the front of the job. If *after* is set, the banner page will come at the end.

```
set model model stty [[-]onlcr] [[-]descramble] [xtab
tablength|none]
```

```
set model m3 stty onlcr
```

Control extra job processing done by the *model*. The processing options are:

**onlcr** Carriage return insertion for Unix text jobs. Adds carriage returns to text jobs with solitary linefeeds. This will prevent stair-stepped output or output running off the right side of the page.

**descramble** Automatic descrambling of print jobs passing through which have been scrambled using the proprietary scramble Unix utility, **npsscramble**.

**xtab** Tab expansion from 1 to 16 spaces.

```
set model model trailer trailerstring
set model m7 trailer $FF
```

Set a trailer string to be sent to the printer at the end of any print jobs passing through this *model*. *trailerstring* can consist of up to nine elements. An example element is a hexadecimal code (e.g., 0x04) or a pre-defined variable on the print server (e.g., \$FF for a formfeed). Use *list var* to see all available variables.

```
set model from default
```

Set all model settings back to factory defaults.

```
set model from stored
```

Set all current model settings to the values stored in flash memory.

```
set prn [-]autofd
```

```
set prn -autofd
```

Assert or do not assert the AUTOFD line for carriage return insertion. This only affects printers that support this function (e.g., impact printers).

```
set prn flush
```

```
set prn flush
```

Flush the data in the parallel port input and output buffers.

```
set prn unlock
```

```
set prn unlock
```

Release the access lock on the parallel port.

```
set prn timeout minutes |none
```

```
set prn timeout none
```

Terminate the print job sent to the parallel port if it is not printed after the timeout period in *minutes* expires. The *minutes* value ranges from 0 though 255 with 0 indicating no timing out to take place. This is the default setting and should be fine for most print setups.

```
set prn [-]opost
```

```
set prn -opost
```

Allow or disallow output processing on the parallel port such as carriage return insertion (i.e., *onlcr*).

```
set prn [-]onlcr
```

```
set prn -onlcr
```

Enable or disable carriage return insertion on the parallel port. This may be needed for Unix text jobs coming through with solitary linefeeds. This feature is almost always set at the model level rather than the I/O port level though.

```
set prn xtab tablength |none
```

```
set prn xtab none
```

Set the tabstop width as indicated by *tablength*. The range is 1 through 16 spaces.

```
set prn from default
```

Set all parallel port settings back to factory defaults.

```
set prn from stored
```

Set all current parallel port settings to the values stored in flash memory.

**set snmp**

To add a user named **snmp** with **root** privileges, please follow the steps below:

1. Login to the NIC as a root user.
2. Add a user named **snmp**.  
**set user add snmp**
3. Set the user type to **root**.  
**set user type snmp root**
4. Set the password for the **snmp** user.  
**set user passwd snmp snmppassword**
5. Save the changes.  
**save**

The user **snmp** is now created and **snmppassword** is the only community string which will allow write access.

**set snmp manager index ipaddress trap-community**

The Print Server continuously generates traps, but unless the trap table is filled in, no SNMP manager will receive this information. To set the Print Server to send traps to a particular SNMP manager, use this command to add an SNMP manager to the trap table.

**index** is the index number of the trap table. **ipaddress** is the IP address of the SNMP manager receiving traps. **trap-community** is the community string sent along with the trap information.

**set sysinfo name newname****set sysinfo name salesprinter**

Set a descriptive name defined by **newname** for NIC identification purposes. This is not used in the operation of the print server in any way.

**set sysinfo location description****set sysinfo location salesdept**

Set the physical location of the NIC. This is for identification purposes and is not used in the operation of the print server in any way.

**set sysinfo contact contactname****set sysinfo contact Paul\_Harris**

Set a person or department to contact in case of print server trouble.

**set sysinfo loginfo [-]sys | [-]tcp | [-]ipx | [-]spx****set sysinfo loginfo -sys ipx**

Set the NIC debugging information type. Usually this information includes unexpected errors or exceptions from the print server divided into these groups:

**sys** General system messages.

**tcp** TCP stack messages.

**ipx** IPX stack messages.

**spx** SPX stack messages.

**Note**

This is not printer or job logging information.

```
set sysinfo logport null|syslog
set sysinfo logport null
```

Define where the debugging information should be sent to. This can be sent to an output device off of the NIC I/O port or to a central TCP/IP host running a SYSLOG daemon. To set this host, use the command **set sysinfo syslog *hostIPAddress***.

```
set sysinfo email emailname@IPAddress
set sysinfo email joe@192.75.11.5
```

Define the user email address to receive printer and job logging information from a particular logpath on the NIC. ***emailname*** is the host or IP name of the user, and ***IPAddress*** is the IP address where the mail is stored on your network.

```
set sysinfo syslog hostIPAddress
set sysinfo syslog 192.75.11.30
```

Set the IP address of the host running the SYSLOG daemon. NIC debugging or print job and printer logging information can be sent to that IP address.

```
set sysinfo dns DNSserverIPAddress
set sysinfo dns 192.75.11.2
```

Set your DNS server IP address so the NIC can resolve host names when used with its built-in Telnet and Ping clients.

```
set sysinfo descramblekey hexvalue
set sysinfo descramblekey 1234
```

Set the key value used for descrambling print jobs that have passed through the **npscramble** utility on a TCP/IP host. This key is a four-digit hexadecimal value obtained from the host software, npscramble. Within the npscramble source code, there is a variable called SR\_KEY which contains the default key value. This can be changed to any four-digit value you would like.

```
set sysinfo module [[-]novell] [[-]netbios]
set sysinfo module -novell
```

Enable and disable certain network protocol stacks within the NIC. Sometimes it helps to disable any protocols you are not using on your network.

```
set time hours [minutes [seconds]]
set time 10 30
```

Set the current time noting the ***hours*** based on the 24-hour system and the ***minutes*** and ***seconds*** ranging from 0 through 59. If the NIC is reset, this value will be lost so you will need to set the time again.

```
set user add|del username
set user add eng
```

Add or remove a user on the NIC defined by *username*.

---

**Note**

Be careful not to delete the **root** user, or you will be unable to configure any further settings on the print server. You will have to go back to factory defaults to correct this problem.

---

```
set user passwd username password
set user passwd eng mplex1
```

Assign a *password* to a defined user on the NIC. This *password* must be less than eleven characters.

```
set user type username root|guest
set user type eng root
```

Assign root or guest privileges to a particular user defined by *username*. Guest permissions allow viewing of settings only. Root permissions allow complete control of the NIC.

```
set user from default
```

Set all user settings back to factory defaults.

```
set user from stored
```

Set all current user settings to the values stored in flash memory.

```
set user passwd snmp com_name
```

Sets the new SNMP R/W community name as the *com\_name* value.

```
set var variablename variablestring
```

```
set var LANDSCAPE 0x1b 0x26 0x6c 0x31 0x4f
```

```
set var FINISH $FF $PCL-RST
```

Define a new variable to be used in header, trailer, or switch strings on the NIC and call it *variablename*. *variablestring* can be a space-separated list of words, hexadecimal numbers (e.g., 0x04), or references to other pre-defined variables. It is easiest to make up the *variablestring* with hexadecimal values as shown in the example.

One variable counts as one element within header and trailer strings.

Defined variables are referenced in strings by placing an **\$** before the variable name (e.g., **set model m1 trailer \$FF**).

```
set var from default
```

Set all variable settings back to factory defaults.

```
set var from stored
```

Set all current variable settings to the values stored in flash memory.

## List Commands

---

These commands list the current or working settings for a particular section within the command shell. To view stored settings in flash memory, you will need to add in **stored** within the beginning of any of the following commands. For example, **list prn** shows you the current prn settings but **list stored prn** shows you the settings sitting in flash memory. Normally these should match.

**list arp**

List the current ARP table that the NIC adheres to in a TCP/IP network.

**list date**

List the current date on the NIC.

**list dest**

List the current destination settings (e.g., names and mapped I/O ports, models, and logpaths).

**list diff**

List the differences between the current settings and the stored settings in flash memory. Normally, you want these values to match, so issue a **save** command followed by a **reset**.

**list ifc**

List the current UTP interface settings (e.g., link integrity).

**list key**

List the license details and license key number.

**list logins**

List any active user logins on the NIC.

**list logpath**

List the current logpath settings (e.g., names and mapped destinations).

**list model**

List the current model settings (e.g., names and mapped destinations).

**list pserver**

List the current general print server settings (e.g., print server name and Novell mode).

**list prn**

List the current parallel port setting (e.g., mode).

**list rprinter**

List any current RPRINTER definitions.

**list snmp**

List Trap Table containing SNMP Managers.

**list sysinfo**

List the current NIC system information (e.g., contact name and protocol stacks enabled).

**list tcpip**

List all current TCP/IP network settings (e.g., IP address and subnet mask).

**list test**

List the status of output tests on the I/O ports.

**list time**

List the current time on the NIC.

**list user**

List the current user definitions (e.g., user names and types).

**list var**

List all pre-defined variables including any newly created ones. Any of these defined variables can be referenced in a string by placing a \$ before the variable name (e.g., `set model m1 trailer $FF`).

## Debug Commands

---

The `debug` set of commands help troubleshoot problems that may occur on the NIC. Some of the output may be cryptic, but it helps when troubleshooting.

**debug eeprom**

List ROM contents.

**debug io**

List statistics from the I/O port module.

**debug ip**

List IP stack statistics.

**debug lpd**

List statistics from the lpd daemon.

**debug lpq**

List statistics from the queue module.

**debug mem**

List statistics from the NIC memory module.

**debug nest fserver**

View the Novell file server(s) the NIC has acknowledged and connected to.

**debug nest ipx**

Determine whether a board has been bound to the NIC under Novell and that the network number is correct for your network.

**debug nest logs**

View miscellaneous Novell log messages.

**debug nest odi**

Determine what frame type is bonded to which board number under Novell.

**debug nest pserver**

View the Novell PSERVER log messages including queues attached to.

**debug nest rprinter**

View the Novell PSERVER and RPRINTER log messages and destinations used on the NIC.

**debug nest sap**

Determine whether the NIC is seeing any Novell network activity.

**debug netbios**

List NetBIOS (i.e., Windows 95 and WfW) statistics.

**debug nif**

List network interface statistics.

**debug novell**

List file and print servers.

**debug tcp**

List TCP stack statistics.

## Miscellaneous Commands

---

These commands do not fall under any specific section of the command shell, but they are used quite frequently.

**save [default]**

Save the current settings to flash memory so they are available after power cycles. Sysinfo, destination, model, logpath, variable, user, and I/O port settings will be saved. If **default** is specified as well, factory settings will be saved, overwriting any new settings you have configured.

**reset**

Perform a warm boot or hardware reset simulating a power-on reset. Restores current settings to those stored in flash memory since the flash memory settings will be read and loaded into memory upon bootup.

**load [default]**

Load the settings stored in flash memory and use them as the current or working settings. If **default** is specified as well, factory settings will be loaded.

**lpstat [ioport] [jobID]****lpstat prn**

Display active and queued jobs and I/O port status for a given **ioport** or **jobID**. Specifying one of these parameters will shorten the output focusing on the particular I/O port or print job specified.

**cancel jobID****cancel dlprn-10**

Remove a job from an I/O port queue. Use **lpstat** to find a particular job ID first.



```
start fox|tts|loopb prn
start fox prn
```

Begin a debugging test on one of the I/O ports on the NIC. The tests available are:

- fox** A continuous stream of text sent to the attached printer. This is a good test for troubleshooting hardware as long as the attached printer supports text output.
- tts** A continuous stream of Gandalf 400C TTS-compatible text sent to the attached printer.
- loopb** Loopback test. Any input characters from the device attached to the I/O port is echoed back.

```
stop prn
stop prn
```

Stop an output test on an I/O port.

```
disable ioport|destination
disable prn
```

Disable an *ioport* so that queued jobs are not printed, or disable a *destination* so jobs can not be queued to it.

```
enable ioport|destination
enable prn
```

Enable an *ioport* so that queued jobs are printed, or enable a *destination* so jobs can be queued to it.

```
close tcp TCPindexnumber
close tcp 3
```

Force a TCP/IP connection between a TCP/IP host and the NIC to close. The *TCPindexnumber* can be retrieved from "debug tcp" output.

```
ping [-s] hostIPAddress [datasize [packetnumber]]
ping 192.75.11.30
```

**ping** another TCP/IP host specified by *hostIPAddress* on the NIC network. *datasize* is the datagram packet size which defaults to 64 bytes if no size is included in the syntax, and *packetnumber* is the number of requests to be sent.

---

**Note**

To use a host or IP name instead of the address, you must have set the DNS server on the NIC. Use the command **set sysinfo dns...** to do this.

---

```
telnet hostIPAddress [escapecharacter]
telnet 192.75.11.35
```

Start a Telnet session with another TCP/IP host specified by *hostIPAddress* on the NIC network. If *escapecharacter* is used, it resets the key sequence used to exit the Telnet session. It will return you to the telnet> prompt where you can execute **quit**. Use the **keycode** command to find out exact escape characters if needed. The default character is CTRL-].

---

**Note**



To use a host or IP name instead of the address, you must have set the DNS server on the NIC. Use the command `set sysinfo dns...` to do this.

---

***chr string***

Echo *string* or redirect *string* to an I/O port using `chr string > ioport`.

**keycode**

Determine the hexadecimal value for a key to be used as the escape character with the NIC built-in telnet command.

---

# 14

## *Extra Features*

---

### NIC Security

---

There are TCP access lists available to restrict host connections with the device.

#### Users And Passwords

---

By default, the NIC supports two logical user types:

**root**      Access to everything within the print server including all configurable settings.

**guest**     Ability to list settings only.

Using set commands, other users can be created.

Passwords can be set for each user type. However, most often you would just set a password for the root user to protect the NIC configuration. Guest users cannot alter the print server configuration in any way.

You can configure a root password on your NIC using either Telnet or a Web browser as follows:

#### Telnet

Using Telnet, set a root password by entering the following commands.

Syntax:

```
set user passwd username password
save
```

Example:

```
set user passwd root your_password_for_root
save
```

---

#### Note



If prompted for a User ID and password first, type in **root** for the user ID and press ENTER at the password prompt since there is no password by default.

---

## Web Browser

1. Using a Web browser, direct the browser to URL  
`http://P5000LJIPaddress/adminConf.html`  
(e.g., `http://192.75.11.9/adminConf.html`)

---

**Note**

If prompted for a User ID and password first, type in `root` for the user ID and press ENTER at the password prompt since there is no password by default.

---

2. At the “Administration Configuration” HTML form that displays, scroll down to the “Passwords” section.
3. Click within the “Old” field beside the “Root Password” heading and enter the existing root password. By default, there is no root password so you can go to the next step without typing anything in this field.
4. Within the “Root Password” section, click within the “New” field and enter the new root password.
5. Within the “Root Password” section, click within the “Confirm” field and enter the new root password again. Remember this is case sensitive.
6. Click on the SUBMIT button when done and physically repower the print server to make the new setting takes effect.

From this point on, anytime you log in to the NIC as `root`, you will need to specify this password or your login attempt will fail.

To clear this password or change it, use the same “Administration Configuration” HTML form. Just enter the appropriate “Old” password and put in the new one (or nothing if you do not want a root password any longer). The commands directly on the NIC are:

```
set user from default
save
```

---

**Note**

Remember your password. If you forget it, the only way to recover your password is as follows:

1. set Dipswitch 1 on the adapter to the “on” position
2. power up
3. set Dipswitch 1 to the “off” position
4. power up a second time.

You will also have to restore all IP values.

---

## TCP Access Lists

Within TCP/IP environments, the NIC can restrict host access to destinations/queues and remote command (i.e., **rsh**, **rcmd**, **remsh** and **telnet**) execution services. This is done using an access list similar in function to the Unix **.rhosts** file.

To view the current access list on the print server, complete the steps below.

---

### Note



Access list settings are not configurable through the HTML forms provided with the NIC.

---

1. Start a Telnet session with the NIC.

Syntax:

```
telnet P5000LJIPaddress
```

2. Log in as **root** and press ENTER at the password prompt since there is no password by default (or your password for your home set).
3. List the current access list.

Syntax:

```
List tcpip
```

If the TCP access table entry list is empty, all hosts have access to the NIC services. If there are entries in the list, only those hosts specified have access to printing and remote command execution.

To add and delete access list entries, the commands are:

Syntax:

```
store tcpip tcp access add|del hostIPaddress |
networkaddress
reset
```

where *hostIPaddress* is the IP address of a TCP/IP host on your network and *networkaddress* is the address of a subnet on your network.

Example:

```
store tcpip tcp access add 192.75.11.25
store tcpip tcp access add 192.75.12.0
store tcpip tcp access del 192.75.11.25
reset
```

---

### Note



Although the maximum number of entries in the access list is 10, each entry can refer to a network rather than a specific host. This allows all hosts on that specified network plus any individual hosts specified in the list to have access.

---

## Printer Monitoring And Logging

One of the key aspects of maintaining a computing environment is monitoring printer status and logging this information to useful places. The NIC allows this through its built-in HTML forms, command set, SNMP traps, e-mail alerts, and logpaths.

### Printer And Print Job Monitoring

To view the current status of an I/O port on the NIC, you can use either Telnet or a Web browser as follows:

#### Telnet

Using Telnet, enter the `lpstat` command directly on the print server (after you have logged in as `guest` or `root`).

#### Web Browser

Using a Web browser, select the desired I/O port on the "Status" HTML form that comes with the NIC:

`http://P5000LJIPaddress/indexStatus.html`  
(e.g., `http://192.75.11.9/indexStatus.html`).

Whether using Telnet or a Web browser, you are given a description of each I/O port status and a list of queued jobs. Table 17 describes some of the common terms you may encounter.

**Table 17. Key Printer Logging Terms**

| Term           | Description                                                                                                                                                                 |
|----------------|-----------------------------------------------------------------------------------------------------------------------------------------------------------------------------|
| <b>idle</b>    | There is no job queued for the NIC I/O port.                                                                                                                                |
| <b>blocked</b> | The printer is not allowing the NIC to send data to it. If this condition persists, check that there is not a printer error and that the printer is online and ready to go. |
| <b>waiting</b> | The NIC knows about a print job but is waiting for the host to send more data or to send an expected packet.                                                                |

## Printer Logging Through Logpaths

Destinations are logical queues with associated models and logpaths. Models allow extra processing needed with the print jobs. Logpaths are used if logging is desired for each job.

Each logpath on the NIC consists of two parts:

**Type** The type of log information to be captured. The choices are **job** for job ID and username, **user** for user ID (and three messages per job), **pgcnt** for total pages printed in a job, **cksum** for file checksums, **printer** for special printer feedback, and **ioport** for parallel printer status messages.

**Port** Where this log information will be sent to. The choices are a **TCP port number** (e.g., 2000), an **email address** (including an alias), or a central host running a **SYSLOG daemon**.

To view the current logpath settings on the print server, you can use either Telnet or a Web browser as follows:

### Telnet

Using Telnet, type the commands and your variable data as shown in the example below:

Syntax:

```
list logpath
list logpath logpath
set logpath logpath port ioport
set logpath logpath type user job
save
```

Example:

```
10.221.1.25:root> list logpath
NAME LOG PORT LOG FLAGS
11 - -
12 - -
13 - -
14 - -
10.221.1.25:root> list logpath 12
 log port:
 log flags:
10.221.1.25:root> set logpath 12 port 9999
ok
10.221.1.25:root> set logpath 12 type user job
 ok: user
 ok: job
save
```

**Note**

If prompted for a User ID and password first, type in **root** for the ID and press ENTER at the password prompt since there is no password by default.

---

**Web Browser**

1. Using a Web browser, direct the browser to URL  
**`http://P5000LJIPaddress/destConf.html`**  
(e.g., **`http://192.75.11.9/destConf.html`**)
- 

**Note**

If prompted for a User ID and password first, type in **root** for the ID and press ENTER at the password prompt since there is no password by default.

---

2. At the “Print Path Configuration” HTML form that displays, select a destination link (e.g., d1prn) from the top of the page to bring up the appropriate destination form.
3. Once the desired destination HTML form displays, scroll down to the “Logpath Type” and “Logpath Port” sections to view the current logpath settings for this particular destination.

Whether using Telnet or a Web browser, you can alter any of these settings at this point and then click on the SUBMIT button to store them into the NIC. Remember to repower the NIC to make the settings take effect.

## NIC Naming Schemes

---

A single I/O Port destination can be configured with a variety of model and logpath combinations. For instance, once you set the parameters for m1 and l1, you can assign the model and logpath to more than one I/O port destination such as d1prn, d2prn, and d8prn. You may now use the same set of model and logpath parameters more than once without having to redefine those parameters each time for another I/O Port destination.



---

# 15

## *Interfaces*

---

### Overview

---

The printer interface is the point where the data line from the host computer plugs into the printer. The interface processes all communications signals and data to and from the host computer. It consists of a printed circuit board assembly (PCBA) and a connector for the data cable from the host computer. Communication signals and data may be sent over Ethernet, parallel, or serial lines.

When data is sent through multiple interfaces, the Autoport Switching feature forces the printer to automatically switch between the serial and parallel port and between the Ethernet adapter and the serial port when NIC is installed.

This chapter describes the following interfaces:

- Centronics
- Bi-Tronics
- RS-232 serial
- RS-422 serial

---

#### Note



To determine which interface is installed on your printer, refer to Table 1 on page 19. If you require a parallel interface and it is not installed, contact your authorized Printronix representative.

---

## Centronics Parallel Interface

The Centronics interface enables the printer to operate with controllers designed for buffered Centronics printers. The length of the data cable from the host computer to the printer must not exceed 15 feet (5 meters).

**Table 18. Centronics Interface Connector Pin Assignments**

| Input Signals     |     | Output Signals |     | Miscellaneous  |         |
|-------------------|-----|----------------|-----|----------------|---------|
| Signal            | Pin | Signal         | Pin | Signal         | Pin     |
| DATA LINE 1       | 2   | ACKNOWLEDGE    | 10  | CHASSIS GROUND | 17      |
| Return            | 20  | Return         | 28  |                |         |
| DATA LINE 2       | 3   | ONLINE         | 13  | GROUND         | 30      |
| Return            | 21  | Return         | 28  |                |         |
| DATA LINE 3       | 4   | FAULT          | 32  | Spares         | 14      |
| Return            | 22  | Return         | 29  |                |         |
| DATA LINE 4       | 5   | PAPER EMPTY    | 12  | No Connection  | 34, 35, |
| Return            | 23  | Return         | 28  |                | 36      |
| DATA LINE 5       | 6   | BUSY           | 11  | +5 Volts       | 18      |
| Return            | 24  | Return         | 29  |                |         |
| DATA LINE 6       | 7   |                |     |                |         |
| Return            | 25  |                |     |                |         |
| DATA LINE 7       | 8   |                |     |                |         |
| Return            | 26  |                |     |                |         |
| DATA LINE 8       | 9   |                |     |                |         |
| Return            | 27  |                |     |                |         |
| DATA STROBE       | 1   |                |     |                |         |
| Return            | 19  |                |     |                |         |
| PAPER INSTRUCTION | 15  |                |     |                |         |
| Return            | 29  |                |     |                |         |
| PRIME             | 31  |                |     |                |         |
| Return            | 30  |                |     |                |         |

## Centronics Interface Signals

---

The Centronics interface signals between the host computer and the printer are defined as follows:

**Data Lines 1 through 8.** Provide eight standard or inverted levels from the host that specify a character or function code. Data Line 8 allows access to the extended ASCII character set. You may enable or disable this line via the Data Bit 8 parameter on the Centronics submenu.

**Data Strobe.** Carries a low true, 100 ns min. pulse from the host that clocks data into the printer.

**Paper Instruction (PI).** Carries a VFU control signal from the host with the same timing as the data lines.

**Acknowledge.** A low true pulse from the printer indicating the character or function code has been received and the printer is ready for the next data transfer.

**Online.** A high true level from the printer to indicate the printer is ready for data transfer and the ON LINE key on the operator panel has been activated. When the printer is in online mode, it may accept data from the host.

**Paper Empty (PE).** A high true level from the printer to indicate the printer is in a fault condition.

**Busy.** A high true level from the printer to indicate the printer cannot receive data.

## Centronics Parallel Interface Configuration

---

Your printer is configured at the factory to match the interface you specified. By using the operator panel, you may verify and change several interface parameters in order to meet specific application requirements.

Refer to "Centronics (Parallel) Submenu" on page 117 for Centronics parameter descriptions and information on selecting values for the following parameters:

- Data Bit 8 (enable or disable)
- Data Polarity (standard or inverted)
- Strobe Polarity (standard or inverted)
- Response Polarity (standard or inverted)
- Busy on Strobe (enable or disable)
- Latch Data On Leading or Trailing Edge of Strobe
- Prime Signal (enable or disable)
- TOF Action at Prime Signal (do nothing or form feed)
- I/O Buffer Size (1-6)

Some application programs require a unique configuration. If the printer is not working properly in the configuration you have selected, contact an authorized Printronix representative.

## Bi-Tronics Parallel Interface

---

Bi-Tronics is a parallel interface with bidirectional capabilities. Features include the following:

- Timing of the signals has been reduced, thereby speeding data transmission.
- Bidirectional communication. Both the host and the printer can send data.
- Versatility. If a device cannot send data along particular lines, the Bi-Tronics interface can send data via other operating modes, such as Nibble Mode which is discussed later.
- Less user interaction. The host can ask the printer about printing status and supported features, such as fonts and internal errors. For example, instead of having to physically check if the printer has run out of paper, you can create a program to query this from the host. The printer will respond and a message will display on the host.

### Operating Modes

---

The Bi-Tronics interface supports three operating modes, which are determined by negotiation between the printer and the host.

#### Compatibility Mode

This mode provides compatibility with Centronics-like host I/O. Data is transferred from the host to the printer in 8-bit bytes over the data lines.

Compatibility mode can be combined with nibble and byte modes to provide bidirectional communication.

#### Nibble Mode

Eight bits equals one byte. When a byte of data is sent to the printer, the eight bits are sent over eight data lines.

Some devices cannot send data over their eight data lines. To bypass this, the Bi-Tronics interface permits data to be sent as half a byte over four status lines. (Half a byte equals one nibble.) Two sequential four-bit nibbles are sent over the lines.

Data is transferred from printer to host in four-bit nibbles over the status lines, and the host controls the transmission.

#### Byte Mode

The printer and host send data to each other along eight data lines (one bit per line).

If bidirectional communication is supported by the printer and the host, the host will take control of the data transfer.

## The Negotiation Phase

---

The negotiation phase determines which operating mode will be used. At this time, the host and the printer will sense what devices are attached, the supported signals available, and which mode to use. The selected mode, in turn, defines the pins on the Bi-Tronics interface connector.

There are 36 pins on the parallel interface. Each one sends a different signal. Pin 1, for example, can send a Strobe signal or a HostClk signal, depending on the mode selected. Table 19 shows the different definitions.

## Signals

---

Bi-Tronics interface signals between the host and the printer are defined below.

**Host Clock / nWrite.** Driven by the host. Data is transferred from host to printer. When the printer sends data, two types are available. In Nibble mode, the signal is set high. In Byte mode, the signal is set low.

**Data 1 through Data 8.** These pins are host-driven in Compatibility mode and bidirectional in Byte mode. They are not used in Nibble mode. Data 1 is the least significant bit; Data 8 is the most significant bit.

**Printer Clock / Peripheral Clock / Interrupt.** Driven by the printer. A signal from the printer indicating the character or function code has been received and the printer is ready for the next data transfer.

**Printer Busy / Peripheral Acknowledge / nWait.** Driven by the printer. Indicates the printer cannot receive data. (Data bits 4 and 8 in Nibble Mode.)

**Acknowledge Data Request / nAcknowledge Reverse.** Driven by the printer. Indicates the printer is in a fault condition. (Data bits 3 and 7 in Nibble mode.)

**Xflag.** Driven by the printer. A high true level indicating the printer is ready for data transfer and the printer is online. (Data bits 2 and 6 in Nibble mode.)

**Host Busy / Host Acknowledge / NDStrobe.** Driven by the host. Activates auto-line feed mode.

**Peripheral Logic High.** Driven by the printer. When set high, the printer indicates all of its signals are in a valid state. When set low, the printer indicates its power is off or its signals are in an invalid state.

**nReverse Request.** Driven by the host. Resets the interface and forces a return to Compatibility mode idle phase.

**nData Available / nPeripheral Request.** Driven by the printer. Indicates the printer has encountered an error. (Data bits 1 and 5 in Nibble mode.)

**1284 Active / nAStrobe.** Driven by the host. A peripheral device is selected.

**Host Logic High.** Driven by the host. When set to high, the host indicates all of its signals are in a valid state. When set to low, the host indicates its power is off or its signals are in an invalid state.

**nInit.** Resets init interface from the host.

**Note**



The length of the data cable from the host computer to the printer should not exceed 10 meters (32 feet).

**Table 19. Bi-Tronics Signals**

| Pin | Source of Data | Type of Mode            |            |            |
|-----|----------------|-------------------------|------------|------------|
|     |                | Compatible              | Nibble     | Byte       |
| 1   | Host           | nStrobe                 | HostClk    | Host/Clk   |
| 2   | Host/Printer   | Data 1 (LSB)            |            |            |
| 3   | Host/Printer   | Data 2                  |            |            |
| 4   | Host/Printer   | Data 3                  |            |            |
| 5   | Host/Printer   | Data 4                  |            |            |
| 6   | Host/Printer   | Data 5                  |            |            |
| 7   | Host/Printer   | Data 6                  |            |            |
| 8   | Host/Printer   | Data 7                  |            |            |
| 9   | Host/Printer   | Data 8 (MSB)            |            |            |
| 10  | Printer        | nAck                    | PtrClk     | PtrClk     |
| 11  | Printer        | Busy                    | PtrBusy    | PtrBusy    |
| 12  | Printer        | PError                  | AckDataReq | AckDataReq |
| 13  | Printer        | Select                  | Xflag      | Xflag      |
| 14  | Host           | nAutoFd                 | Host Busy  | HostAck    |
| 15  |                | Not Defined             |            |            |
| 16  |                | Logic Grid              |            |            |
| 17  |                | Chassis Grid            |            |            |
| 18  | Printer        | Peripheral Logic High   |            |            |
| 19  |                | Signal Ground (nStrobe) |            |            |
| 20  |                | Signal Ground (Data 1)  |            |            |
| 21  |                | Signal Ground (Data 2)  |            |            |
| 22  |                | Signal Ground (Data 3)  |            |            |
| 23  |                | Signal Ground (Data 4)  |            |            |

Table 19. Bi-Tronics Signals (continued)

| Pin | Source of Data | Type of Mode                              |             |             |
|-----|----------------|-------------------------------------------|-------------|-------------|
|     |                | Compatible                                | Nibble      | Byte        |
| 24  |                | Signal Ground (Data 5)                    |             |             |
| 25  |                | Signal Ground (Data 6)                    |             |             |
| 26  |                | Signal Ground (Data 7)                    |             |             |
| 27  |                | Signal Ground (Data 8)                    |             |             |
| 28  |                | Signal Ground (PErrror, Select, nAck)     |             |             |
| 29  |                | Signal Ground (Busy, nFault)              |             |             |
| 30  |                | Signal Ground (nAutoFd, nSelectIn, nInit) |             |             |
| 31  | Host           | nInit                                     |             |             |
| 32  | Printer        | NFault                                    | nDataAvail  | aDataAvail  |
| 33  |                | Not Defined                               |             |             |
| 34  |                | Not Defined                               |             |             |
| 35  |                | Not Defined                               |             |             |
| 36  | Host           | nSelectIn                                 | 1284 Active | 1284 Active |

## RS-232 And RS-422 Serial Interfaces

### Note



The RS-232 and RS-422 serial interface circuit characteristics are compatible with the Electronic Industry Association Specifications EIA®-232-E and EIA-422-B.

The RS-232 and RS-422 serial interfaces enable the printer to operate with bit serial devices that are compatible with an RS-232 controller. The input serial data transfer rate (in baud) is selectable from the printer operator panel. Baud rates of 600, 1200, 2400, 4800, 9600, 19,200, and 38,400 are available for RS-232 and RS-422.

The input format consists of a single start bit, 7 or 8 data bits, and one or two stop bits. The number of data bits is determined by printer configuration. The data bits are interpreted with the least significant bit first. Parity checking is determined by printer configuration options selected from the operator panel.

The printer interface uses a first-in/first-out buffer. The asynchronous interface accepts data as it is provided by the host. The length of the data cable from the host computer to the printer must not exceed 50 feet (15 meters) for RS-232 or 4000 feet (1220 meters) for RS-422. (A copper conductor, twisted-pair telephone cable with a shunt capacitance of 16 pF/foot [52.5 pF/meter] terminated in a 100 ohm resistive load must be used for the RS-422.)

Table 20. RS-232 Serial Interface Connector Pin Assignments

| Input Signals             |     | Output Signals            |     | Miscellaneous  |     |
|---------------------------|-----|---------------------------|-----|----------------|-----|
| Signal                    | Pin | Signal                    | Pin | Signal         | Pin |
| Receive Data (RD)         | 3   | Transmit Data (TD)        | 2   | Chassis Ground | 1   |
| Clear To Send (CTS)       | 5   | Request To Send (RTS)     | 4   | Signal Ground  | 7   |
| Data Set Ready (DSR)      | 6   | Data Terminal Ready (DTR) | 20  |                |     |
| Data Carrier Detect (DCD) | 8   |                           |     |                |     |

Table 21. RS-422 Serial Interface Connector Pin Assignments

| Input Signals        |     | Output Signals        |     | Miscellaneous  |     |
|----------------------|-----|-----------------------|-----|----------------|-----|
| Signal               | Pin | Signal                | Pin | Signal         | Pin |
| - Receive Data (-RD) | 15  | - Transmit Data (-TD) | 19  | Chassis Ground | 1   |
| + Receive Data (+RD) | 17  | + Transmit Data (+TD) | 25  | Signal Ground  | 7   |

## RS-232 And RS-422 Serial Interface Signals

The RS-232/RS-422 connector mounted on the printer is a 25-pin DB-25S type. The mating connector is a DB-25P. RS-232 and RS-422 compatible serial interface signals are defined as follows:

### RS-232

**Transmitted Data (TD).** Serial data stream from the printer for transmitting status and control information to the host. Subject to protocol selection.

**Received Data (RD).** Serial data stream to the printer.

**Request To Send (RTS).** Control signal from the printer. Subject to configuration.

**Clear To Send (CTS).** Status signal to the printer indicating the host is ready to receive data/status signals from the printer.

**Data Set Ready (DSR).** Status signal to the printer indicating the host is in a ready condition.



**Data Carrier Detect (DCD).** Status signal to the printer. The ON condition is required for the printer to receive data.

**Data Terminal Ready (DTR).** Control signal from the printer. Subject to configuration.

## **RS-422**

**+RD, -RD.** Serial data stream differentially received by printer.

**+TD, -TD.** Differentially driven serial data stream for transmitting status and control information to the host. Subject to protocol selection.

---

**Note**

$\pm$ RD and  $\pm$ TD form signal and return paths of a differential line signal.

---

## **RS-232 And RS-422 Serial Interface Protocol**

---

**X-ON/X-OFF.** The printer transmits an X-ON character (hex 11) when entering the Online mode or when the buffer is almost empty. The printer transmits an X-OFF character (hex 13) when entering the Offline mode or when the buffer is almost full.

## **RS-232 And RS-422 Serial Interface Error Handling**

---

---

**Note**

All serial errors are treated as faults that require operator intervention.

---

**Parity Error Handling.** Parity error checking is a configuration option selected from the operator panel.

With odd or even parity checking selected, a character with a parity error is replaced with a question mark (?) character.

When parity checking is not selected ("NONE" on the operator panel), parity errors are ignored and the characters are printed as received.

**Framing Error Handling.** Framing error checking is always in effect for the serial interface.

When a framing error occurs, an exclamation point (!) is printed. If 20 successive errors are received, a line feed is added to force printing to occur.

**Overrun Error Handling.** Overrun error checking is always in effect for the serial interface.

When a data overrun error occurs, an asterisk (\*) is printed. If 20 successive errors are received, a line feed is added to force printing to occur.

## **RS-232 And RS-422 Serial Interface Configuration**

---

By using the control panel, you can verify and change several interface parameters in order to meet specific application requirements.

Refer to “Serial Submenu” on page 119 for RS-232 and RS-422 parameter descriptions and information on selecting values for the following parameters:

### **RS-232 and RS-422**

- Baud Rate (data rate selected from the operator panel)
- Data Bits (7 or 8 Bits)
- Stop Bits (1 or 2 Bits)
- Parity (None, Odd, Even, Mark or Sense)

### **RS-232 only**

- Data Terminal Ready logic
- Request to Send logic

Some application programs require a unique configuration. If the printer is not working properly with the configuration you selected, contact an authorized Printronix representative.

---

# 16

## *Routine Service And Diagnostics*

---

### Routine Service

---

Periodic cleaning ensures efficient operation and clear print quality, and it is the only maintenance your printer requires. If the printer is located in a dusty area or is used for heavy duty printing, clean it more often.

If print quality does not improve even after cleaning, contact your authorized Printronix representative.

---

#### Warning



**Disconnect the power source before cleaning the printer.**

**Vor dem Säubern des Druckers ist die Netzverbindung zu unterbrechen.**

**Débranchez l'alimentation avant de nettoyer l'imprimante.**

**Desconecte la fuente de energía antes de limpiar la impresora.**

**Staccare la fonte di energia prima della pulitura della stampante.**

---

### Exterior Cleaning

---

Clean with a soft, lint-free cloth and mild detergent soap. (Dishwashing liquid works well.) Do not use abrasive powders or chemical solvents. Clean the windows with plain water or mild window cleaner. Always apply the cleaning solution to the cloth; never pour cleaning solution directly onto the printer.

### Interior Cleaning

---

Over time, particles of paper and ink accumulate inside impact printers. This is normal. Paper dust and ink build-up must be removed periodically to avoid degraded print quality. Most paper dust accumulates around the ends of the platen and ribbon path.

To clean the interior of the printer, perform the following steps and refer to Figure 22 for cabinet models.

1. Power off the printer and unplug the printer power cord.
2. Open the printer cover. Fully raise the forms thickness lever. Unload paper. Refer to the *P5000LJ Series Printers Quick Reference Guide*.

3. Unlatch both ribbon spools and carefully lift them off the hubs. Raise the ribbon out of the ribbon path.
4. Using a soft-bristled, non-metallic brush (such as a toothbrush), brush paper dust and ribbon lint off the tractors, shuttle cover assembly, base casting, and ribbon guides. Vacuum up the residue.

---

**Caution**

**Vacuum carefully around the hammer bank and surrounding area to avoid damage.**

---

5. Wipe the splined shaft with a soft cloth.
6. Check the ribbon mask and hammer bank cover for bits of torn paper or ribbon lint. Check the holes in the ribbon mask surrounding each hammer tip. Gently remove paper or lint particles with a wooden stick or pair of tweezers. (Do not pry or apply force to the hammer tips.)
7. Using a soft cloth lightly moistened with anhydrous alcohol (no water), remove dust and ink from the platen. (The platen is the thick silver bar behind the hammer bank cover that rotates when the forms thickness lever is rotated.) Clean the ribbon guides.

---

**Caution**

**When cleaning the platen, be very careful not to get any alcohol in the hammer bank, because alcohol will cause severe damage to the hammer bank. Only a trained service technician should clean the shuttle assembly.**

---

8. Brush and vacuum up dust or residue that has accumulated inside the lower cabinet.
9. For cabinet models:  
Wipe the lower cabinet interior with a clean, lint-free cloth dampened (not wet) with water and mild detergent, or spray the surfaces lightly with window cleaning solution. Dry the lower cabinet interior by wiping it with a clean, lint-free cloth.
10. For models with a power paper stacker:  
Wipe all power stacker components using a soft cloth lightly moistened with anhydrous alcohol (no water) to remove dust.
11. Reinstall the ribbon and load paper. Refer to the *P5000LJ Series Printers Quick Reference Guide*.

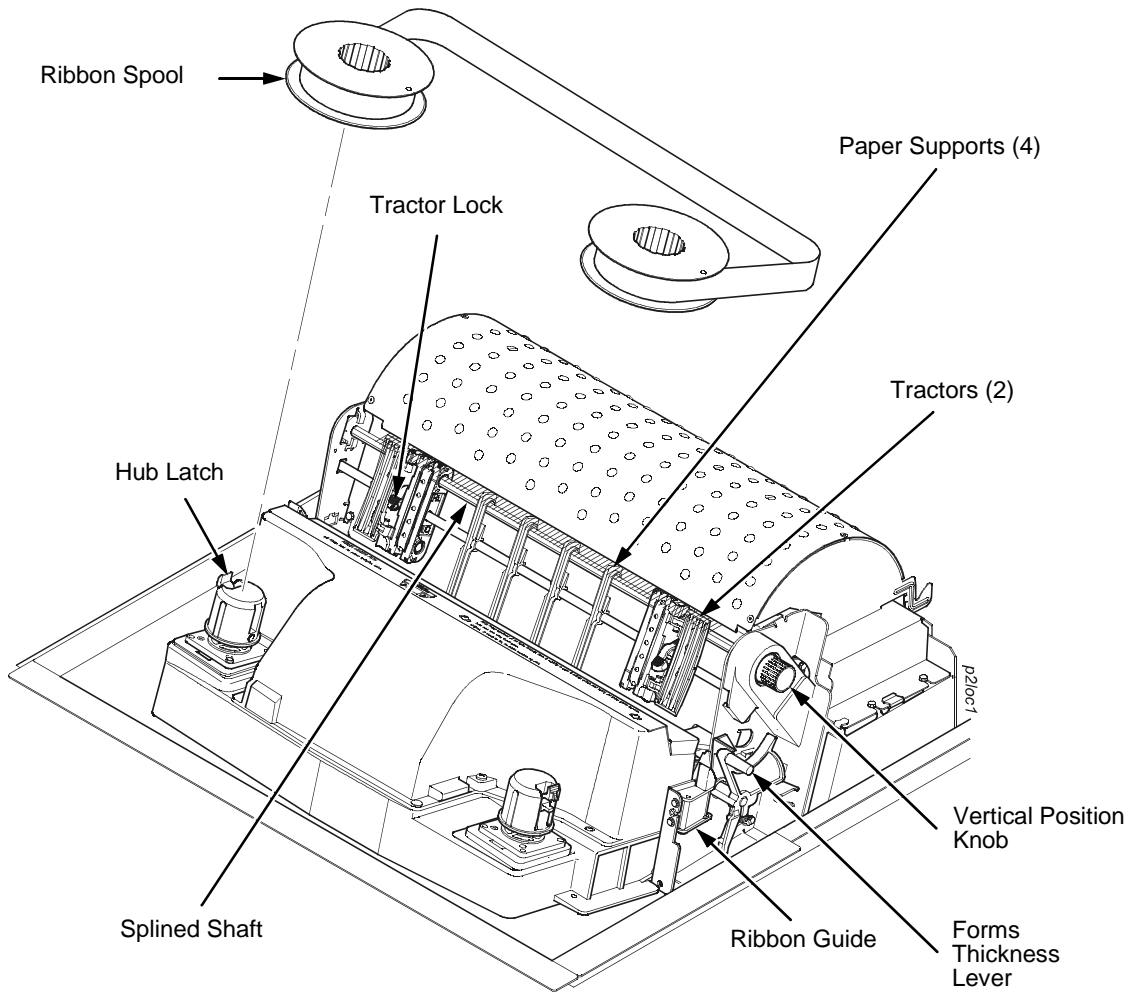

Figure 22. Cleaning the Print Mechanism (Cabinet Models)

## Diagnosing Problems

This section is designed to help you recover from any problems which may arise with normal printer operation.

### Printer Self-Tests

The printer self-tests are used to check the print quality and operation of your printer. Your authorized Printronix representative will typically run these tests. For a description of each test, see page 129.

To activate a test, select it and press the ENTER key. To stop the test, press ENTER again.

#### Note



Whenever you run a self-test, the top-of-form setting is lost. You must reset the top-of-form. See your *P5000LJ Series Printers Quick Reference Guide*.

An example procedure for running the self-test "All E's," which determines whether print quality is acceptable, is described in Table 22.

**Table 22. Sample Print Test (All E's)**













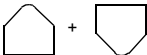

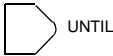
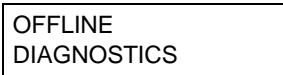

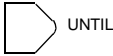
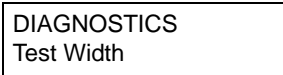



| Step | Key                                                                                                                       | Result                                                                              | Notes                                     |
|------|---------------------------------------------------------------------------------------------------------------------------|-------------------------------------------------------------------------------------|-------------------------------------------|
| 1.   | Install the ribbon. Load full-width (136-column) computer paper. Set top-of-form. See your <i>Quick Reference Guide</i> . |                                                                                     |                                           |
| 2.   | ON LINE<br>                            |  | The printer must be offline for testing.  |
| 3.   |                                        |  | Allows you to make configuration changes. |
| 4.   |                                        |  |                                           |
| 5.   |                                        |  |                                           |
| 6.   |                                        |  |                                           |

Table 22. Sample Print Test (All E's) (continued)

| Step | Key                                                                                                                                                                                                  | Result                          | Notes                                                                      |
|------|------------------------------------------------------------------------------------------------------------------------------------------------------------------------------------------------------|---------------------------------|----------------------------------------------------------------------------|
| 7.   |                                                                                                                     | Test Width<br>Full Width*       |                                                                            |
| 8.   |  OR                                | Test Width<br>X                 | Cycle through the choices.<br>X = <b>Full Width</b> or <b>80 columns</b> . |
| 9.   | ENTER<br>                                                                                                           | Test Width<br>X*                | The width you have chosen will be used for the printer test.               |
| 10.  |  UNTIL                                                                                                              | DIAGNOSTICS<br>Test Width       |                                                                            |
| 11.  |  UNTIL                                                                                                              | DIAGNOSTICS<br>Printer Tests    |                                                                            |
| 12.  |                                                                                                                     | Printer Tests<br>Shift Recycle* |                                                                            |
| 13.  |  OR                              | Printer Tests<br>All E's        |                                                                            |
| 14.  | ENTER<br>                                                                                                         | Printer Tests<br>All E's*       | Starts the test.                                                           |
| 15.  | ENTER<br>                                                                                                         | Printer Tests<br>All E's*       | Stops the test.                                                            |
| 16.  |  +                             | ENTER SWITCH<br>LOCKED          | Locks the ENTER key.                                                       |
| 17.  | ON LINE<br>                                                                                                       | ONLINE                          |                                                                            |
| 18.  | Examine the print quality. The characters should be fully formed and of uniform density. If the test does not run or characters appear malformed, contact your authorized Printronix representative. |                                 |                                                                            |
| 19.  | If the print quality is good, set the top-of-form.                                                                                                                                                   |                                 |                                                                            |

## Printing A Hex Dump

```

!"#$%&'()*+,-./ 20 21 22 23 24 25 26 27 28 29 2A 2B 2C 2D 2E 2F
0123456789:;<=>? 30 31 32 33 34 35 36 37 38 39 3A 3B 3C 3D 3E 3F
@ABCDEFGHIJKLMNO 40 41 42 43 44 45 46 47 48 49 4A 4B 4C 4D 4E 4F
PQRSTUVWXYZ[\]^_ 50 51 52 53 54 55 56 57 58 59 5A 5B 5C 5D 5E 5F
`abcdefghijklmno 60 61 62 63 64 65 66 67 68 69 6A 6B 6C 6D 6E 6F
pqrstuvwxyz{|}~ 70 71 72 73 74 75 76 77 78 79 7A 7B 7C 7D 7E 7F
!"#$%&'()*+,-./ 21 22 23 24 25 26 27 28 29 2A 2B 2C 2D 2E 2F 30
123456789:;<=>?@ 31 32 33 34 35 36 37 38 39 3A 3B 3C 3D 3E 3F 40
ABCDEFGHIJKLMN! "#$%& 41 42 43 44 45 46 47 48 0D 0A 21 22 23 24 25 26
'()*+,-./0123456 27 28 29 2A 2B 2C 2D 2E 2F 30 31 32 33 34 35 36
789:;<=>?@ABCDEF 37 38 39 3A 3B 3C 3D 3E 3F 40 41 42 43 44 45 46
GHIJKLMNOPQRSTU 47 48 49 4A 4B 4C 4D 4E 4F 50 51 52 53 54 55 56
WXYZ[\]^_`abcdef 57 58 59 5A 5B 5C 5D 5E 5F 60 61 62 63 64 65 66
ghijklmnopqrstu 67 68 69 6A 6B 6C 6D 6E 6F 70 71 72 73 74 75 76
vwxyz{|}~ !"#$%&' 77 78 79 7A 7B 7C 7D 7E 20 21 22 23 24 25 26 27
'()*+,-./01234567 28 29 2A 2B 2C 2D 2E 2F 30 31 32 33 34 35 36 37
89:;<=>?@ABCDEF 38 39 3A 3B 3C 3D 3E 3F 40 41 42 43 44 45 46 47
HI.!"#$%&'()*+,- 48 49 0D 0A 22 23 24 25 26 27 28 29 2A 2B 2C 2D
./0123456789:;<= 2E 2F 30 31 32 33 34 35 36 37 38 39 3A 3B 3C 3D
>?@ABCDEFGHIJKLM 3E 3F 40 41 42 43 44 45 46 47 48 49 4A 4B 4C 4D
NOPQRSTUVWXYZ[\] 4E 4F 50 51 52 53 54 55 56 57 58 59 5A 5B 5C 5D
^_`abcdefghijklm 5E 5F 60 61 62 63 64 65 66 67 68 69 6A 6B 6C 6D
nopqrstuvwxyz{|} 6E 6F 70 71 72 73 74 75 76 77 78 79 7A 7B 7C 7D
~ !"#$%&'()*+,- 7E 20 21 22 23 24 25 26 27 28 29 2A 2B 2C 2D 2E
/0123456789:;<=> 2F 30 31 32 33 34 35 36 37 38 39 3A 3B 3C 3D 3E
?@ABCDEFGHIJ.!"#$ 3F 40 41 42 43 44 45 46 47 48 49 4A 0D 0A 23 24
%&'()*+,-./01234 25 26 27 28 29 2A 2B 2C 2D 2E 2F 30 31 32 33 34
56789:;<=>?@ABCD 35 36 37 38 39 3A 3B 3C 3D 3E 3F 40 41 42 43 44
EFGHIJKLMNOPQRST 45 46 47 48 49 4A 4B 4C 4D 4E 4F 50 51 52 53 54
UVWXYZ[\]^_`abcd 55 56 57 58 59 5A 5B 5C 5D 5E 5F 60 61 62 63 64
efghijklmnopqrst 65 66 67 68 69 6A 6B 6C 6D 6E 6F 70 71 72 73 74
uvwxyz{|}~ !"#$% 75 76 77 78 79 7A 7B 7C 7D 7E 20 21 22 23 24 25
&'()*+,-./012345 26 27 28 29 2A 2B 2C 2D 2E 2F 30 31 32 33 34 35
6789:;<=>?@ABCDE 36 37 38 39 3A 3B 3C 3D 3E 3F 40 41 42 43 44 45
FGHIJK.!"#$%&'()*+ 46 47 48 49 4A 4B 0D 0A 24 25 26 27 28 29 2A 2B
,-./0123456789: 2C 2D 2E 2F 30 31 32 33 34 35 36 37 38 39 3A 3B
<=>?@ABCDEFGHIJK 3C 3D 3E 3F 40 41 42 43 44 45 46 47 48 49 4A 4B
LMNOPQRSTUVWXYZ[4C 4D 4E 4F 50 51 52 53 54 55 56 57 58 59 5A 5B
\]^_`abcdefghijkl 5C 5D 5E 5F 60 61 62 63 64 65 66 67 68 69 6A 6B
lmnopqrstuvwxyz{| 6C 6D 6E 6F 70 71 72 73 74 75 76 77 78 79 7A 7B
}~ !"#$%&'()*+,- 7C 7D 7E 20 21 22 23 24 25 26 27 28 29 2A 2B 2C

```

**Figure 23. Hex Dump Sample**



A hex code printout (or hex dump) is a translation of all host interface data to its hexadecimal or symbolic equivalent. A hex dump lists all ASCII character data received from the host computer with their corresponding two-digit hexadecimal codes. Hex dumps are used to troubleshoot printer data reception problems.

Printable characters print as the assigned symbol; nonprintable characters are indicated by a period (.).

See Appendix C for hex-to-ASCII conversion. Table 23 shows the procedure for printing a hex dump.

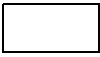
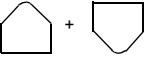
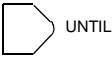

Table 23. Printing a Hex Dump

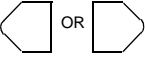
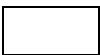
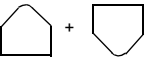
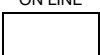
| Step | Key                                                                                                                                  | Result                        | Notes                                            |
|------|--------------------------------------------------------------------------------------------------------------------------------------|-------------------------------|--------------------------------------------------|
| 1.   | Make sure the printer is on. Raise the printer cover.                                                                                |                               |                                                  |
| 2.   | ON LINE<br>                                         | OFFLINE<br>CONFIG. CONTROL    | The printer must be offline for testing.         |
| 3.   |                                                     | ENTER SWITCH<br>UNLOCKED      | Allows you to make configuration changes.        |
|      |                                                                                                                                      | OFFLINE<br>CONFIG. CONTROL    |                                                  |
| 4.   |                                                     | OFFLINE<br>MAINT / MISC       |                                                  |
| 5.   |                                                     | MAINT / MISC<br>Hex Dump Mode |                                                  |
| 7.   |                                                    | Hex Dump Mode<br>Disable*     |                                                  |
| 8.   |                                                   | Hex Dump Mode<br>Enable       | Cycle through the choices.                       |
| 9.   | ENTER<br>                                         | Hex Dump Mode<br>Enable*      | An asterisk (*) indicates this choice is active. |
| 16.  |                                                   | ENTER SWITCH<br>LOCKED        | Locks the ENTER key.                             |
| 17.  | ON LINE<br>                                       | ONLINE                        |                                                  |
| 18.  | Go to the host computer and send a file. The printer outputs a hex dump. Refer to the ASCII chart in Appendix C.                     |                               |                                                  |
| 19.  | When the hex dump is complete, change the Hex Dump Mode back to Disable by following the steps outlined above and selecting Disable. |                               |                                                  |

## **Fault Messages**

---

If a fault condition occurs in the printer, the status indicator on the control panel flashes on and off, and the message display indicates the specific fault. Fault messages are summarized in Table 24.

Displayed faults fall into one of two categories:

- Operator correctable
- Field service required

For operator correctable faults, follow the suggested corrective action in the fault message description. After correcting the displayed fault, press the CLEAR key to clear the error message and status indicator, and resume printing. If the fault message reappears, contact your authorized Printronix representative.

### **Fault Messages Requiring Field Service Attention**

For faults that require field service, do two things to try to clear the fault before calling your authorized Printronix representative:

1. Set the printer power switch to O (off), wait 15 seconds, then turn the printer on again. Run your print job again. If the message does not appear, it was a false indication and no further attention is required.
2. If the message reappears, press the CLEAR key. If the message goes away, it was a false indication and no further attention is required. If the message reappears, call your authorized Printronix representative.

Table 24 explains the fault messages and offers solutions where possible.

Table 24. LCD Message Troubleshooting Table

| Displayed Message           | Explanation                                                                                                                        | Action Required                                                                                                                                          |
|-----------------------------|------------------------------------------------------------------------------------------------------------------------------------|----------------------------------------------------------------------------------------------------------------------------------------------------------|
| 8.5V PWR FAIL*              | Internal power failure.                                                                                                            | Contact your authorized Printronix representative. <sup>1</sup>                                                                                          |
| 15V PWR FAIL*               | Controller voltage failure.                                                                                                        | Contact your authorized Printronix representative. <sup>1</sup>                                                                                          |
| 23.5V PWR FAIL*             | Controller voltage failure.                                                                                                        | Contact your authorized Printronix representative. <sup>1</sup>                                                                                          |
| 48V PWR FAIL*               | Internal power failure.                                                                                                            | Contact your authorized Printronix representative. <sup>1</sup>                                                                                          |
| A TO D OVERUN*              | Fatal firmware error on controller board.                                                                                          | Contact your authorized Printronix representative. <sup>1</sup>                                                                                          |
| ACCESS NULL PTR*            | Fatal firmware error on controller board.                                                                                          | Contact your authorized Printronix representative. <sup>1</sup>                                                                                          |
| BUFFER OVERRUN              | Host sends data after the printer buffer is full. (Serial interface.)                                                              | Check your serial host interface parameter settings; if necessary, adjust them so they match the settings of the attached host.                          |
| CLEAR PAPER JAM             | No paper motion.                                                                                                                   | Clear jam and reload paper. (See <i>Quick Reference Guide</i> .) If this message recurs, contact your authorized Printronix representative. <sup>1</sup> |
| CLEARING PROGRAM FROM FLASH | The program successfully loaded into printer RAM and the checksum matched. The old program is now being deleted from flash memory. | None                                                                                                                                                     |
| CLOSE PLATEN                | The forms thickness lever is open.                                                                                                 | Close the forms thickness lever.                                                                                                                         |
| COIL HOT*                   | One or more hammer coils are overheating.                                                                                          | Contact your authorized Printronix representative. <sup>1</sup>                                                                                          |
| CTL VOLT FAIL*              | Controller voltage failure.                                                                                                        | Contact your authorized Printronix representative. <sup>1</sup>                                                                                          |
| DIAGNOSTIC PASSED           | The printer passed its memory and hardware initialization tests.                                                                   | None                                                                                                                                                     |
| DRVR CIR BAD*               | Hammer coil count test failed.                                                                                                     | Contact your authorized Printronix representative. <sup>1</sup>                                                                                          |

Table 24. LCD Message Troubleshooting Table (continued)

| Displayed Message                | Explanation                                                                              | Action Required                                                                                                       |
|----------------------------------|------------------------------------------------------------------------------------------|-----------------------------------------------------------------------------------------------------------------------|
| ERROR: DC PROGRAM NOT VALID      | Printer cannot find the data controller program or the validation checksum is corrupt.   | Download the program again. If the message occurs again, call your authorized Printronix representative. <sup>1</sup> |
| ERROR: DRAM AT ADDRESS XXXXXXXX  | The printer found a defective memory location.                                           | Call your authorized Printronix representative. <sup>1</sup>                                                          |
| ERROR: EC PROGRAM NOT VALID      | Printer cannot find the engine controller program or the validation checksum is corrupt. | Download the program again. If the message occurs again, call your authorized Printronix representative. <sup>1</sup> |
| ERROR: EC STOPPED AT STATE XXXX  | Hardware fault in the engine controller.                                                 | Call your authorized Printronix representative. <sup>1</sup>                                                          |
| ERROR: FLASH DID NOT PROGRAM     | The printer encountered an error trying to program flash memory.                         | Download the program again. If the message occurs again, call your authorized Printronix representative. <sup>1</sup> |
| ERROR: FLASH NOT DETECTED        | The printer could not find any flash memory.                                             | Call your authorized Printronix representative. <sup>1</sup>                                                          |
| ERROR: NO DRAM DETECTED          | The printer could not find any DRAM.                                                     | Call your authorized Printronix representative. <sup>1</sup>                                                          |
| ERROR: NVRAM FAILURE             | The security PAL is not present or the non-volatile memory has failed.                   | Call your authorized Printronix representative. <sup>1</sup>                                                          |
| ERROR: PROGRAM NEEDS MORE DRAM   | The printer requires more DRAM memory in order to run the downloaded program.            | Add DRAM. Call your authorized Printronix representative. <sup>1</sup>                                                |
| ERROR: PROGRAM NEEDS MORE FLASH  | The printer requires more flash memory in order to run the downloaded program.           | Add flash memory. Call your authorized Printronix representative. <sup>1</sup>                                        |
| ERROR: PROGRAM NOT COMPATIBLE    | The printer is not compatible with the downloaded program.                               | Use the correct emulation software option(s) for this model.                                                          |
| ERROR: PROGRAM NOT VALID         | The printer does not see a program in flash memory.                                      | There is no program in printer memory. Download program again.                                                        |
| ERROR: SECURITY PAL NOT DETECTED | The security PAL is not present or has failed.                                           | Call your authorized Printronix representative. <sup>1</sup>                                                          |
| ERROR: SHORT AT ADDRESS XXXX     | Hardware failure in DRAM or CMX controller circuitry.                                    | Call your authorized Printronix representative. <sup>1</sup>                                                          |

Table 24. LCD Message Troubleshooting Table (continued)

| Displayed Message                  | Explanation                                                                                                       | Action Required                                                                                                                                                                                                                                                                                                                                              |
|------------------------------------|-------------------------------------------------------------------------------------------------------------------|--------------------------------------------------------------------------------------------------------------------------------------------------------------------------------------------------------------------------------------------------------------------------------------------------------------------------------------------------------------|
| ERROR: WRITING TO FLASH            | Hardware or software fault in flash memory.                                                                       | Download the program again. If the message occurs again, call your authorized Printronix representative. <sup>1</sup>                                                                                                                                                                                                                                        |
| ERROR: WRONG CHECKSUM              | The printer received the complete program but the checksum did not match. The data was corrupted during download. | Download the program again. If the message occurs again, call your authorized Printronix representative. <sup>1</sup>                                                                                                                                                                                                                                        |
| ETHERNET ADAPTER BEING INITIALIZED | NIC is processing the boot procedure.                                                                             | None                                                                                                                                                                                                                                                                                                                                                         |
| ETHERNET DETECTED                  | NIC has established communication.                                                                                | None                                                                                                                                                                                                                                                                                                                                                         |
| EXHAUST FAN FLT                    | Sensors cannot detect current in fan circuit.                                                                     | Power off the printer and remove the paper path. Check that the fan cable connector is connected. Check for obstruction of vents and fan airway, and remove any obstructions. Check for items beneath the printer blocking cabinet vents. Power back on the printer. If this message recurs, contact your authorized Printronix representative. <sup>1</sup> |
| FIRMWARE ERROR*                    | Application software tried to perform an illegal printer function or damaged memory detected on board.            | Contact your authorized Printronix representative. <sup>1</sup>                                                                                                                                                                                                                                                                                              |
| FRAMING ERROR                      | Serial framing error. (Serial interface.)                                                                         | Check your serial host interface parameter settings; if necessary, adjust them so that they match the settings of the attached host.                                                                                                                                                                                                                         |
| HAM. COIL OPEN*                    | Electrical malfunction of one or more hammer coils.                                                               | Contact your authorized Printronix representative. <sup>1</sup>                                                                                                                                                                                                                                                                                              |
| HAMMER COIL BAD X, X, X,...        | Coil # failed current test at power-up.                                                                           | Record message, clear to continue printing, and contact your authorized Printronix representative.                                                                                                                                                                                                                                                           |
| HB NOT INSTALLED*                  | Self-test does not detect hammer coils.                                                                           | Contact your authorized Printronix representative. <sup>1</sup>                                                                                                                                                                                                                                                                                              |

Table 24. LCD Message Troubleshooting Table (continued)

| Displayed Message             | Explanation                                                                                                      | Action Required                                                                                                                                                                                                                                                                                                                    |
|-------------------------------|------------------------------------------------------------------------------------------------------------------|------------------------------------------------------------------------------------------------------------------------------------------------------------------------------------------------------------------------------------------------------------------------------------------------------------------------------------|
| HMR BANK FAN FLT              | Sensors cannot detect current in fan circuit.                                                                    | Power off printer and remove paper path. Check that fan cable is connected. Check for obstruction of vents and fan airway; remove any obstructions. Check for items beneath the printer blocking cabinet vents. Power back on the printer. If this message recurs, contact your authorized Printronix representative. <sup>1</sup> |
| ILL EXT BUS ACC*              | Fatal firmware error on controller board.                                                                        | Contact your authorized Printronix representative. <sup>1</sup>                                                                                                                                                                                                                                                                    |
| ILL INST ACCSS*               | Fatal firmware error on controller board.                                                                        | Contact your authorized Printronix representative. <sup>1</sup>                                                                                                                                                                                                                                                                    |
| ILLGL OPR ACCSS*              | Fatal firmware error on controller board.                                                                        | Contact your authorized Printronix representative. <sup>1</sup>                                                                                                                                                                                                                                                                    |
| INTAKE FAN FAULT              | Sensors cannot detect current in fan circuit.                                                                    | See description for HMR BANK FAN FLT.                                                                                                                                                                                                                                                                                              |
| LO DRV. SHORT *               | Circuit(s) on the hammer bank or in the hammer bank power cable shorted to ground.                               | Contact your authorized Printronix representative. <sup>1</sup>                                                                                                                                                                                                                                                                    |
| LOAD PAPER                    | Printer is out of paper.                                                                                         | Load paper. (See <i>Quick Reference Guide</i> .)                                                                                                                                                                                                                                                                                   |
| LOADING PROGRAM FROM PORT XX% | The new program is loading into printer RAM. XX indicates how much of the program has loaded.                    | None                                                                                                                                                                                                                                                                                                                               |
| LOADING PROGRAM INTO FLASH    | The printer has deleted the previous program from flash memory and is loading the new program into flash memory. | None                                                                                                                                                                                                                                                                                                                               |
| PAP BAD TABLE*                | Fatal firmware error on controller board.                                                                        | Contact your authorized Printronix representative. <sup>1</sup>                                                                                                                                                                                                                                                                    |
| PAP BSY TOO LNG*              | Fatal firmware error on controller board.                                                                        | Contact your authorized Printronix representative. <sup>1</sup>                                                                                                                                                                                                                                                                    |
| PAP FIFO OVERFL*              | Fatal firmware error on controller board.                                                                        | Contact your authorized Printronix representative. <sup>1</sup>                                                                                                                                                                                                                                                                    |
| PAP FIFO UNDRFL*              | Fatal firmware error on controller board.                                                                        | Contact your authorized Printronix representative. <sup>1</sup>                                                                                                                                                                                                                                                                    |

**Table 24. LCD Message Troubleshooting Table (continued)**

| Displayed Message | Explanation                                                                                                                      | Action Required                                                                                                                 |
|-------------------|----------------------------------------------------------------------------------------------------------------------------------|---------------------------------------------------------------------------------------------------------------------------------|
| PAP ILLGL ST*     | Fatal firmware error on controller board.                                                                                        | Contact your authorized Printronix representative. <sup>1</sup>                                                                 |
| PAP INCMPL ENER*  | Fatal firmware error on controller board.                                                                                        | Contact your authorized Printronix representative. <sup>1</sup>                                                                 |
| PAP INVLD CMD*    | Fatal firmware error on controller board.                                                                                        | Contact your authorized Printronix representative. <sup>1</sup>                                                                 |
| PAP INVLD PARM*   | Fatal firmware error on controller board.                                                                                        | Contact your authorized Printronix representative. <sup>1</sup>                                                                 |
| PAP NOT SCHED*    | Fatal firmware error on controller board.                                                                                        | Contact your authorized Printronix representative. <sup>1</sup>                                                                 |
| PAP NT AT SPEED*  | Fatal firmware error on controller board.                                                                                        | Contact your authorized Printronix representative. <sup>1</sup>                                                                 |
| PAP UNEXP INT*    | Fatal firmware error on controller board.                                                                                        | Contact your authorized Printronix representative. <sup>1</sup>                                                                 |
| PARITY ERROR      | Parity error (serial interface)                                                                                                  | Check your serial host interface parameter settings; if necessary, adjust them so they match the settings of the attached host. |
| PLAT INV CMD*     | Fatal firmware error on controller board.                                                                                        | Contact your authorized Printronix representative. <sup>1</sup>                                                                 |
| PLAT INV PARM*    | Fatal firmware error on controller board.                                                                                        | Contact your authorized Printronix representative. <sup>1</sup>                                                                 |
| PLAT INV STATE*   | Fatal firmware error on controller board.                                                                                        | Contact your authorized Printronix representative. <sup>1</sup>                                                                 |
| POWER SAVER MODE  | Status message: printer is in low-energy idle state; all fans and higher voltages are off; only +5Vdc logic circuits are active. | None                                                                                                                            |
| POWER SUPPLY HOT* | Circuits are overheating on the power supply board.                                                                              | Contact your authorized Printronix representative. <sup>1</sup>                                                                 |
| PRINTER HOT*      | Controller board sensors report high temperatures on the board.                                                                  | Contact your authorized Printronix representative. <sup>1</sup>                                                                 |
| PROTECTED INSTR*  | Fatal firmware error on controller board.                                                                                        | Contact your authorized Printronix representative. <sup>1</sup>                                                                 |
| PWR SUPP VOLT *   | Power supply failed.                                                                                                             | Replace power supply board.                                                                                                     |

Table 24. LCD Message Troubleshooting Table (continued)

| Displayed Message                  | Explanation                                                                                                               | Action Required                                                                                                                                                                      |
|------------------------------------|---------------------------------------------------------------------------------------------------------------------------|--------------------------------------------------------------------------------------------------------------------------------------------------------------------------------------|
| RESETTING . . .<br>PLEASE WAIT     | The printer finished loading the program into flash memory and is automatically resetting itself.                         | None                                                                                                                                                                                 |
| RESTORING<br>BOOT CODE             | Normal download initialization message.                                                                                   | None                                                                                                                                                                                 |
| RIB INVLD CMD*                     | Fatal firmware error on controller board.                                                                                 | Contact your authorized Printronix representative. <sup>1</sup>                                                                                                                      |
| RIB INVLD STATE*                   | Fatal firmware error on controller board.                                                                                 | Contact your authorized Printronix representative. <sup>1</sup>                                                                                                                      |
| RIBBON DRIVE*                      | CMX controller does not detect ribbon drive motor.                                                                        | Contact your authorized Printronix representative. <sup>1</sup>                                                                                                                      |
| RIBBON INK OUT<br>CHANGE RIBBON    | RibbonMinder software has determined that the ribbon is out of ink.                                                       | Install a new ribbon and set ribbon life to 100%.                                                                                                                                    |
| SECURITY CODE<br>VIOLATION*        | Security code of PAL on controller board does not match code of firmware on the controller board.                         | Contact your authorized Printronix representative. <sup>1</sup>                                                                                                                      |
| SECURITY PAL NOT<br>DETECTED       | The security PAL is missing or has failed.                                                                                | Contact your authorized Printronix representative. <sup>1</sup>                                                                                                                      |
| SENDING PROGRAM<br>TO EC PROCESSOR | The printer is loading the engine controller program into the engine controller.                                          | None                                                                                                                                                                                 |
| SHUTL INV CMD*                     | Fatal firmware error on controller board.                                                                                 | Contact your authorized Printronix representative. <sup>1</sup>                                                                                                                      |
| SHUTL INV PARM*                    | Fatal firmware error on controller board.                                                                                 | Contact your authorized Printronix representative. <sup>1</sup>                                                                                                                      |
| SHUTTLE JAM                        | No shuttle movement or shuttle is moving at the wrong speed.                                                              | Check for obstruction to shuttle, a twisted ribbon, or forms thickness lever closed too tightly. If fault source is not apparent, contact your authorized Printronix representative. |
| SOFTWARE ERROR *<br>Cycle power    | Application software tried to perform illegal printer function, or damaged logic circuits were found on controller board. | Contact your authorized Printronix representative. <sup>1</sup>                                                                                                                      |
| STACK OVERFLOW*                    | Fatal firmware error on controller board.                                                                                 | Contact your authorized Printronix representative. <sup>1</sup>                                                                                                                      |



**Table 24. LCD Message Troubleshooting Table (continued)**

| Displayed Message                                                                                                                                                                                                                                                                                   | Explanation                                                                                        | Action Required                                                 |
|-----------------------------------------------------------------------------------------------------------------------------------------------------------------------------------------------------------------------------------------------------------------------------------------------------|----------------------------------------------------------------------------------------------------|-----------------------------------------------------------------|
| STACK UNDERFLOW*                                                                                                                                                                                                                                                                                    | Fatal firmware error on controller board.                                                          | Contact your authorized Printronix representative. <sup>1</sup> |
| STACKER FAULT                                                                                                                                                                                                                                                                                       | Failed motor circuit.                                                                              | Contact your authorized Printronix representative. <sup>1</sup> |
| STACKER FULL                                                                                                                                                                                                                                                                                        | Reached full capacity.                                                                             | Remove paper stack.                                             |
| STACKER JAM                                                                                                                                                                                                                                                                                         | Jammed paper, or foreign object, in unit's travel path.                                            | Remove paper or foreign object.                                 |
| TABLE MISMATCH<br>DOWNLOAD AGAIN                                                                                                                                                                                                                                                                    | EC software update in progress.                                                                    | Download the program again.                                     |
| TCB CORRUPTED*                                                                                                                                                                                                                                                                                      | Fatal firmware error on controller board.                                                          | Contact your authorized Printronix representative. <sup>1</sup> |
| UNDEF INTERRUPT*                                                                                                                                                                                                                                                                                    | Fatal firmware error on controller board.                                                          | Contact your authorized Printronix representative. <sup>1</sup> |
| UNDFNED OPCODE*                                                                                                                                                                                                                                                                                     | Fatal firmware error on controller board.                                                          | Contact your authorized Printronix representative. <sup>1</sup> |
| UP DRV. SHORT *                                                                                                                                                                                                                                                                                     | Hammer driver circuits on the boards shorted to ground.                                            | Contact your authorized Printronix representative. <sup>1</sup> |
| WAITING FOR<br>ETHERNET ADAPTER                                                                                                                                                                                                                                                                     | This status message appears when the printer is first powered on if the optional NIC is installed. | None                                                            |
| <sup>1</sup> Before contacting an authorized Printronix representative, power off the printer, wait 15 seconds, then power it back on and rerun your print job. If the message reappears, press CLEAR. If the fault message still displays, then contact your authorized Printronix representative. |                                                                                                    |                                                                 |



# A

## *Printer Specifications And Regulatory Information*

### **Ribbon Specifications**

Use only these Hewlett-Packard ribbons in LP Series and LineJet printers:

| <b>Printronix Part Number</b>                             | <b>HP Product Reference</b> | <b>Quantity</b> | <b>Ribbon Type</b> | <b>Yield</b>                                  | <b>Compatibility</b>                                                                                                                |
|-----------------------------------------------------------|-----------------------------|-----------------|--------------------|-----------------------------------------------|-------------------------------------------------------------------------------------------------------------------------------------|
| High Yield Gold Series Ribbons for Increased Productivity |                             |                 |                    |                                               |                                                                                                                                     |
| 172293-001                                                | N/A                         | 6 pack          | Text/Barcode/OCR   | 30 Million Characters<br>3400 Shipping Labels | All Printronix line matrix printers<br>All HP LineJet and LP Series printers                                                        |
| 175006-001                                                | N/A                         | 6 pack          | Text/Barcode/OCR   | 50 million characters<br>4800 shipping labels | All Printronix line matrix printers<br><br>All HP LineJet and LP Series printers                                                    |
| 179006-001                                                | N/A                         | 6 pack          | Text/Barcode/OCR   | 90 million characters<br>7400 shipping labels | All Printronix cabinet model line matrix printers<br><br>HP LineJet 500Q, 1000Q, 1500LQ<br><br>HP LPQ500k, LPQ1000, LPQ1500, LPQ475 |

## Appendix A Ribbon Specifications

| Printronix Part Number | HP Product Reference | Quantity | Ribbon Type         | Yield                                         | Compatibility                                                                                                                                               |
|------------------------|----------------------|----------|---------------------|-----------------------------------------------|-------------------------------------------------------------------------------------------------------------------------------------------------------------|
| Standard Ribbons       |                      |          |                     |                                               |                                                                                                                                                             |
| 107675-001             | C3207A               | 6 pack   | Text                | 30 million characters                         | All Printronix line matrix printers<br><br>All HP LineJet and LP Series printers                                                                            |
| 107675-007             | C3208A               | 6 pack   | Text                | 50 million characters                         | All Printronix cabinet model line matrix printers<br><br>HP LineJet 500Q, 1000Q, 1500Q<br><br>HP LPQ500, LPQ1000, LPQ1500, LPQ475, LPQ800, LPQ1200, LPQ1400 |
| 107675-005             | C3209A               | 6 pack   | Barcode/OCR         | 27 million characters<br>2800 shipping labels | All Printronix line matrix printers<br><br>All HP LineJet and LP Series printers                                                                            |
| 107675-008             | C3210A               | 6 pack   | Barcode/OCR         | 45 million characters<br>4667 shipping labels | All Printronix cabinet model line matrix printers<br><br>HP LineJet 500Q, 1000Q, 1500Q<br><br>HP LPQ500, LPQ1000, LPQ1500, LPQ475, LPQ800, LPQ1200, LPQ1400 |
| 140768-001             | C3212A               | 6 pack   | Non-inked, security | 30 million characters                         | All Printronix line matrix printers<br><br>All HP LineJet and LP Series printers                                                                            |

Note



Genuine Printronix ribbons can be used in all HP LineJet and LP-Series printers.

---

## **Genuine Printronix P5000LJ Supplies**

---

For additional information or to locate the Genuine PRINTRONIX Supplies distributor in your area, e-mail [p5000lj@printronix.com](mailto:p5000lj@printronix.com) or contact:

### **United States**

Phone: 800.733.1900

Fax: 714.368.2600

### **Europe, the Middle East, and Africa**

Phone: 33.1.46.25.1900

Fax: 33.1.46.25.1919

### **Asia Pacific**

Phone: 65.6548.4116

Fax: 65.6546.1588

## Printer Dimensions

---

### Cabinet Model:

|         |                                                                |
|---------|----------------------------------------------------------------|
| Height: | 42.5 inches (108 cm)                                           |
| Width:  | 27 inches (68.6 cm)                                            |
| Depth:  | 29 inches (73.7 cm)                                            |
| Weight: | 225 lbs. (102.1 kg) unpackaged<br>285 lbs. (129.3 kg) packaged |

### Cabinet Model with Power Stacker Option

|         |                                                            |
|---------|------------------------------------------------------------|
| Height: | 42.5 inches (108 cm)                                       |
| Width:  | 27 inches (68.6 cm)                                        |
| Depth:  | 32.5 inches (82.5 cm)                                      |
| Weight: | 246 lbs. (112 kg) unpackaged<br>306 lbs. (139 kg) packaged |

### Pedestal Model:

|         |                                                              |
|---------|--------------------------------------------------------------|
| Height: | 35 inches (88.9 cm)                                          |
| Width:  | 24.6 inches (62.5 cm)                                        |
| Depth:  | 20.7 inches (52.6 cm)                                        |
| Weight: | 105 lbs. (47.6 kg) unpackaged<br>115 lbs. (52.2 kg) packaged |

## Environmental Characteristics

---

### Temperature

#### Operating:

41° to 104° F (5° to 40° C) up to 5000 feet (1524 meters)

41° to 90° F (5° to 32° C) up to 8000 feet (2438 meters)

#### Storage:

- 40° to 158° F (- 40° to 70° C)

### Relative Humidity

Operating: 15% to 80% (non-condensing)

Storage: 10% to 90% (non-condensing)

## ENERGY STAR®

P5000LJ printers comply with the requirements of the ENERGY STAR® Office Equipment Program of the U.S. Environmental Protection Agency. When in the reduced power state, the printer displays "Power Saver Mode," and is activated at the control panel.

## Electrical Characteristics

| Current                        |             |            |             |                     |            |
|--------------------------------|-------------|------------|-------------|---------------------|------------|
|                                | LJ500P      | LJ500Q     | LJ1000Q     | LJ1500Q<br>LJ1500QS | LJ1500P    |
| Printing, Typical <sup>1</sup> | 2.15A       | 2.43A      | 3.28A       | 4.37A               | 3.72A      |
| Printing, Maximum <sup>2</sup> | 3.60A       | 3.05A      | 4.39A       | 6.06A               | 5.19A      |
| Non-Printing <sup>3</sup>      | 0.90A       | 1.17A      | 1.19A       | 1.16A               | 1.10A      |
| Power                          |             |            |             |                     |            |
| Printing, Typical <sup>1</sup> | 190W        | 191W       | 271W        | 364W                | 310W       |
| Printing, Maximum <sup>2</sup> | 320W        | 244W       | 380W        | 514W                | 440W       |
| Non-Printing <sup>3</sup>      | 90W         | 84W        | 86W         | 84W                 | 80W        |
| Heat                           |             |            |             |                     |            |
| Printing, Typical <sup>1</sup> | 648 BTU/hr  | 652 BTU/hr | 925 BTU/hr  | 1342 BTU/hr         | 1058BTU/hr |
| Printing, Maximum <sup>2</sup> | 1092 BTU/hr | 833 BTU/hr | 1297 BTU/hr | 1754 BTU/hr         | 1502BTU/hr |
| Non-Printing <sup>3</sup>      | 307 BTU/hr  | 287 BTU/hr | 294 BTU/hr  | 287 BTU/hr          | 273BTU/hr  |

<sup>1</sup> Printing, Typical = 120 VAC, 50/60 Hz, Shift Recycle (ASCII Swirl), High Speed Mode

<sup>2</sup> Printing, Maximum = 120 VAC, 50/60 Hz, All Black, High Speed Mode

<sup>3</sup> Non-Printing = 120 VAC, 50/60 Hz, Standby Mode

## **Material Safety Data Sheets**

---

If the customer site needs a Material Safety Data Sheet, provide the following information:

- Printronix P5000LJ Model
- Chemical substance description
- Customer name
- Customer address
- Customer telephone number
- Customer FAX number



---

## Communication Notices

---

**Federal Communications Commission (FCC) Statement:** This equipment has been tested and found to comply with the limits for a Class A digital device, pursuant to Part 15 of the FCC Rules. These limits are designed to provide reasonable protection against harmful interference when the equipment is operated in a commercial environment. This equipment generates, uses, and can radiate radio frequency energy and, if not installed and used in accordance with the instruction manual, may cause harmful interference to radio communications. Operation of this equipment in a residential area is likely to cause harmful interference, in which case the user will be required to correct the interference at his own expense.

Properly shielded and grounded cables and connectors must be used in order to meet FCC emission limits. Printronix is not responsible for any radio or television interference caused by using other than recommended cables and connectors or by any unauthorized changes or modifications to this equipment. Unauthorized changes or modifications could void the user's authority to operate the equipment.

This device complies with Part 15 of the FCC Rules. Operation is subject to the following two conditions: (1) this device may not cause harmful interference, and (2) this device must accept any interference received, including interference that may cause undesired operation.

**Canadian Department of Communications Compliance Statement:** This Class A digital apparatus complies with Canadian ICES-003.

**Avis de conformité aux normes du ministère des Communications du Canada:** Cet appareil numérique de la classe A est conforme à la norme NMB-003 du Canada.

**European Community (EC) Conformity Statement:**

This product is in conformity with the protection requirements of EC Council Directive 89/336/EEC on the approximation of the laws of the Member States relating to electromagnetic compatibility. Printronix cannot accept responsibility for any failure to satisfy the protection requirements resulting from a non-recommended modification of the product, including the fitting of non-Printronix option cards.

**German Conformity Statement:**

Zulassungsbescheinigung Gesetz über die elektromagnetische Verträglichkeit von Geräten (EMVG) vom 30. August 1995

Dieses Gerät ist berechtigt in Übereinstimmung mit dem deutschen das EG-Konformitätszeichen - CE - zu führen.

Der Aufsteller der Konformitätserklärung ist die Printronix.....(1)

Informationen in Hinsicht EMVG Paragraph 3 Abs. (2) 2:

|                                                                                  |
|----------------------------------------------------------------------------------|
| Das Gerät erfüllt die Schutzanforderungen nach EN 50082-1 und EN 55022 Klasse A. |
|----------------------------------------------------------------------------------|

EN 55022 Klasse A Geräte bedürfen folgender Hinweise:

Nach dem EMVG: "Geräte dürfen an Orten, für die sie nicht ausreichend entstört sind, nur mit besonderer Genehmigung des Bundesministers für Post und Telekommunikation oder des Bundesamtes für Post und Telekommunikation betrieben werden. Die Genehmigung wird erteilt, wenn keine elektromagnetischen Störungen zu erwarten sind." (Auszug aus dem EMVG, Paragraph 3, Abs. 4) Dieses Genehmigungsverfahren ist nach Paragraph 9 EMVG in Verbindung mit der entsprechenden Kostenverordnung (Amtsblatt 14/93) kostenpflichtig.

Nach der EN 55022: "Dies ist eine Einrichtung der Klasse A. Diese Einrichtung kann im Wohnbereich Funkstörungen verursachen; in diesem Fall kann vom Betreiber verlangt werden, angemessene Maßnahmen durchzuführen und dafür aufzukommen."

Anmerkung: Um die Einhaltung des EMVG sicherzustellen sind die Geräte, wie in den Handbüchern angegeben, zu installieren und zu betreiben.

This product has been tested and found to comply with the limits for Class A Information Technology Equipment according to European Standard EN 55022. The limits for Class A equipment were derived for commercial and industrial environments to provide reasonable protection against interference with licensed communication equipment.

**Warning**

This is a Class A product. In a domestic environment this product may cause radio interference in which case the user may be required to take adequate measures.

警告使用者:  
這是甲類的資訊產品, 在居住的環境中使用時, 可能會造成射頻干擾, 在這種情況下, 使用者會被要求採取某些適當的對策。

注意  
この装置は、第一種情報技術装置です。この装置を家庭環境で使用すると電波妨害を引き起こすことがあります。この場合には使用者が適切な対策を講ずるよう要求されることがあります。 VCCI-A

---

此为A级产品。在生活环境中，该产品可能会造成无线电干扰。在这种情况下，可能需要用户对其干扰采取切实可行的措施。



---

# B

## *Paper Specifications And Forms Design*

---

### Introduction

P5000LJ Series printers use dot matrix line printing technology, which permits a high degree of printing flexibility. Dot matrix technology enables the user to print graphic images, line drawn characters, special characters, and multiple alphabets.

The first section of this appendix lists general specifications for continuous form paper. (Specific brands or types of paper are not recommended.) Adherence to these specifications will ensure the best print quality and reliable operation.

The second section goes into more detail, providing definitions, guidelines, and a checklist to use for designing forms that will run smoothly through the print station of the P5000LJ Series printer.

---

### General Paper Specifications

This section describes the minimum paper specifications that must be met to ensure the best printer performance.

Always test paper and forms before buying large quantities. Make all measurements at 20° to 26° Celsius (68° to 78° Fahrenheit) and 45% to 55% relative humidity. P500LJ printers perform well with forms that meet the specifications listed in Table 25 and Table 26 below.

---

#### Note



Printronix conforms to ANSI® Standard X3.96-1983, "American National Forms Information Systems for Continuous Business Forms," and ISO Recommendation No. 2784, which cover common form widths and depths, standards for sprocket feed holes and margins, and other basic tolerances.

---

**Table 25. Paper Sizes**

|                        |                                     |
|------------------------|-------------------------------------|
| Maximum form width     | 17.0 inches (43.18 cm) edge to edge |
| Minimum form width     | 3.0 inches (7.62 cm) edge to edge   |
| Maximum Printing Width | 13.6 inches (34.54 cm)              |
| Maximum Right Margin   | 1 to 13.6 inches (2.54 to 34.54 cm) |
| Maximum Left Margin    | 0 to 13.5 inches (0 to 34.29 cm)    |
| Maximum Form Length    | 16 inches (40.64 cm)                |
| Minimum Form Length    | 2 inches (5.08 cm)                  |

**Table 26. Paper Weights**

|                          |                                                           |
|--------------------------|-----------------------------------------------------------|
| <b>Single-Part Forms</b> |                                                           |
| Standard                 | 15 to 100 pound (57 to 380 gm/meter <sup>2</sup> )        |
| Best Print Quality       | 18 to 60 pound (68 to 227 gm/meter <sup>2</sup> )         |
| <b>Multipart Forms</b>   |                                                           |
| Carbon Paper             | 12 pounds (46 gm/meter <sup>2</sup> ) up to 6 total pages |
| Carbons                  | 8 pounds (30 gm/meter <sup>2</sup> ) up to 6 total pages  |
| Pack Thickness           | Maximum 0.025 inch (0.635 mm) total                       |
| Carbonless               | Up to 4-part forms                                        |

Test the paper first if you plan to use it in environments with humidity of less than 20% or greater than 80%. Also test paper that you plan to use at high humidity to ensure satisfactory feeding and handling, and test paper to be used at low humidity to determine if static buildup must be eliminated for proper paper stacking.

## Paper Guidelines

---

The terms below describe continuous form paper.

### Terms And Definitions

---

|                  |                                                                                                                                                                                                                                    |
|------------------|------------------------------------------------------------------------------------------------------------------------------------------------------------------------------------------------------------------------------------|
| Chaff            | Residual bits of paper not completely removed after the punch process that creates tractor pin holes, major and minor perforations, etc.                                                                                           |
| Cut Point        | The area along a perforation where a cut has been made that extends through the entire form.                                                                                                                                       |
| Cut-to-Tie Ratio | The ratio of cut points to tie points occurring along a perforation.                                                                                                                                                               |
| Evenness         | The amount of variation between the thickest and thinnest points measured across the print area (i.e., between the side perforations).                                                                                             |
| Form Thickness   | Thickness measured at the thickest point of the entire form. This includes glue lines, compressed staples, perforations, etc., and is not limited to the printed region of the form.                                               |
| Margin           | The region outside the print area of the form. The margin is typically bounded by the outermost vertical perforations (i.e., where the tractor holes are located) and the edge of the form.                                        |
| Print Area       | The region where printing occurs, and which is always between the side perforations.                                                                                                                                               |
| Print Station    | The area in the printer where the actual impacts of printing occur.                                                                                                                                                                |
| Staple           | A punch-cut fastening stitch located along the vertical edge and within the side perforation region of a multipart form. (Note that this is <i>not</i> a metal staple.)                                                            |
| Tenting          | The measured thickness between the print area of the form and the peak thickness of a major perforation. Tenting is typically caused by overly stiff perforations or incorrect registration of the inner parts of multipart forms. |
| Tie Point        | The area along a perforation between the cut points (see above).                                                                                                                                                                   |

The figures below illustrate the terms used in this appendix.

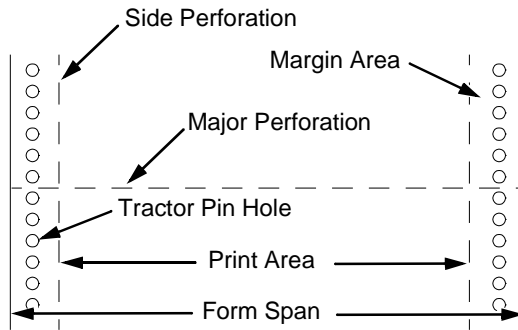

Figure 24. Basic Forms Terminology

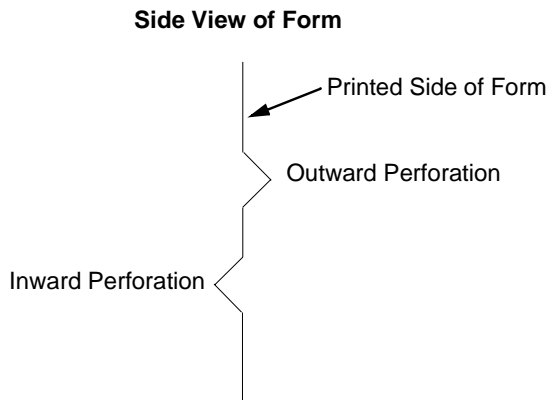

Figure 25. Inward and Outward Perforations

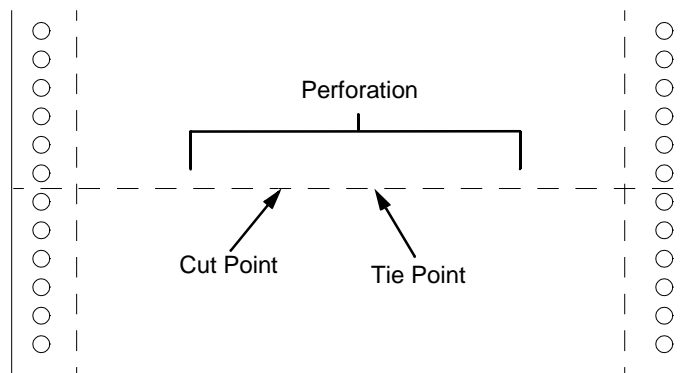

Figure 26. Cut Points and Tie Points



## Environmental Considerations

---

Before they are used, forms should be stored for at least 24 hours—preferably 48 hours—in the environment in which they will be used. This stabilizes the moisture content of the paper, resulting in better feeding and stacking. Forms should *never* be stored in environments that result in damage such as delamination of glues, creasing, folding, etc.

## Form Types

---

Three kinds of continuous form paper are specified for use with the printer:

- Edge-perforated, fanfolded, single-part forms
- 2- to 6-part multipart carbon forms
- 2- to 4-part multipart carbonless forms

For all forms, the width range is from 3 to 17 inches, and the length range is from 2 to 12 inches.

## Form Weight

---

Use 15 to 100 pound (6.80 to 45.36 kg) stock. Light weight and recycled forms must be strong enough to assure that tractor holes and perforations do not tear or detach during form feed, skipping, and ejecting operations.

## Form Thickness

---

Forms must be no thicker than 0.025 inches (0.0635 cm). This figure is for the thickest point of the form—including glue lines, staples, perforations, etc.—and is not restricted to just the print area.

## Form Evenness

---

The evenness of forms must not exceed 0.003 inches (0.00762 cm) across the print area (between the side perforations).

Tenting caused by buildup of perforation thickness must be minimized. A perforation thickness measured at the major perforation that exceeds 1.25 times the forms thickness measured in the print area will result in an unpredictable and unreliable form. The perforation thickness must never exceed the maximum forms thickness of 0.025 inches (0.0635 cm).

## Tractor Pin Engagement

---

The printer uses tractors with 6-pin engagement. Detailed engagement specifications are given in ISO-2784, but are summarized in the table below.

| Specification                                                                                                              | Inches        | Millimeters |
|----------------------------------------------------------------------------------------------------------------------------|---------------|-------------|
| Hole centerline (CL) to edge of form                                                                                       | 0.236 ± 0.028 | 6.0 ± 0.10  |
| Hole Diameter (Serrations or any occlusion due to incorrect registration of multipart forms cannot exceed this dimension.) | 0.156 ± 0.004 | 4.0 ± 0.10  |
| Distance between centers of two consecutive holes                                                                          | 0.500 ± 0.002 | 12.7 ± 0.05 |
| Maximum deviation of holes from their centerline                                                                           | 0.004         | 0.10        |
| Maximum deviation of lefthand hole to adjacent righthand hole (CL to CL)                                                   | 0.006         | 0.15        |
| Maximum parallel deviation of lefthand hole CL to righthand hole CL                                                        | 0.006         | 0.15        |

## Methods Of Forms Attachment

Any method of attachment (staples, crimps, gluing, etc.) must be designed in a way that does not permit air to be trapped between copies of a form. Hard or wire brads and staples must not be used.

Any attachment must not coincide with the major perforation or any horizontal perforation.

### Gluing

Gluing must be controlled and uniform, since it is a major contributor to the maximum form thickness. A form that meets the maximum forms thickness requirement in the print area but which exceeds the maximum thickness at a glue line is considered an unreliable and unpredictable form.

### Staples

Staples must be used only in the margin area of the form and must not be in line with the path of the tractor holes. Ideally, staples are placed in the margins so that they coincide with areas of the form where printing does not occur.

The figure below shows acceptable and unacceptable ways of fabricating staples.

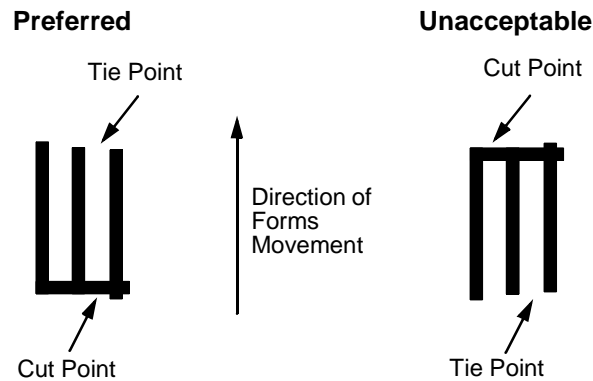

### Cut-To-Tie Ratio

A common cut-to-tie ratio for bond forms is 4:1 (that is, 80% cut to 20% ties). This value is dictated chiefly by the application program under which the form runs. Lower cut-to-tie ratios will yield better form handling, but stacking may suffer due to increased stiffness of the perforations. Some level of experimentation is required to determine the best cut-to-tie ratio. But remember that a cut-to-tie ratio that causes a thickness buildup of greater than 0.025 inch (0.635 mm) or that creates an evenness variation of greater than 0.003 inch (0.0762 mm) will result in an unreliable and unpredictable form.

### Perforation Intersections

Whenever a horizontal perforation intersects with a vertical perforation, the point of intersection must be a tie point. Cut points at such intersections make the form unacceptable.

### Chaff Content

Tractors holes should be clear of chaff. As much as possible, there should not be loose chaff in the box in which the paper is packed.

## Form Design Checklist

Use this checklist to help you remember key areas of consideration when designing and ordering forms and paper stocks.

### Environment

- \_\_\_\_\_ Before they are used, forms are given at least 24 hours of condensing time in the environment in which they will be used.
- \_\_\_\_\_ Forms are not stored in environments that result in damage such as delamination of glue lines, creasing, folding, etc.

### Type Of Form

| Form Type (Check One) |        |        |        |        |        |
|-----------------------|--------|--------|--------|--------|--------|
| 1 Part                | 2 Part | 3 Part | 4 Part | 5 Part | 6 Part |
|                       |        |        |        |        |        |

<----- Carbonless Range ----->

<----- Carbon Range ----->

Recycled Paper? Yes \_\_\_\_\_ No \_\_\_\_\_ If yes, assure adequate form strength to prevent tractor holes and perforations from tearing or detaching during form feeds and page ejects.

Security Form? Yes \_\_\_\_\_ No \_\_\_\_\_ If yes, the last page of the form should have a minimum 50% reflectance, and, if possible, the stippled page faces inward to the form.

### Form Weight

Form weight = \_\_\_\_\_  
 (Minimum = 15 lb. / 6.8 kg ; Maximum = 100 lb / 45.36 kg)

### Form Thickness

Form thickness = \_\_\_\_\_  
 (0.025 inches / 0.0635 cm maximum measured at the thickest point of the form, which includes perforations, compressed staples, glue lines, etc.)

## Form Evenness

The evenness of the form = \_\_\_\_\_  
(Not to exceed 0.003 in. / 0.00762 cm)

Tenting due to buildup of perforation thickness must be minimized. A perforation thickness measured at the major perforation that exceeds 1.25 times the forms thickness measured in the print area will result in an unreliable and unpredictable form. Perforation thickness must not exceed the maximum form thickness of 0.025 in. / 0.0635 cm.

## Tractor Pin Holes

The holes which engage the tractor pins must conform to the following specifications:

| Specification                                                                                                              | Inches        | Millimeters |
|----------------------------------------------------------------------------------------------------------------------------|---------------|-------------|
| Hole centerline (CL) to edge of form                                                                                       | 0.236 ± 0.028 | 6.0 ± 0.1   |
| Hole Diameter (Serrations or any occlusion due to incorrect registration of multipart forms cannot exceed this dimension.) | 0.156 ± 0.004 | 4.0 ± 0.1   |
| Distance between centers of two consecutive holes                                                                          | 0.500 ± 0.002 | 12.7 ± 0.05 |
| Maximum deviation of holes from their centerline                                                                           | 0.004         | 0.1         |
| Maximum deviation of lefthand hole to adjacent righthand hole (CL to CL)                                                   | 0.006         | 0.15        |
| Maximum parallel deviation of lefthand hole CL to righthand hole CL                                                        | 0.006         | 0.15        |

## Methods Of Forms Attachment

- \_\_\_\_\_ Must not allow air entrapment between copies of the form
- \_\_\_\_\_ Must not use hard brads or staples
- \_\_\_\_\_ Must not coincide with major perforation or any horizontal perforation
- \_\_\_\_\_ Gluing lines must not result in a form that exceeds 0.025 in. / 0.0635 cm thickness
- \_\_\_\_\_ Staples must be used only in margin area of form
- \_\_\_\_\_ Staple cuts must not be in the direction of form movement through the tractors
- \_\_\_\_\_ Staples must not occur in-line with the path of the tractor holes
- \_\_\_\_\_ Staples should be placed in the margins so that they coincide with areas of the form where printing will not occur

### Cut-To-Tie Ratio

\_\_\_\_:\_\_\_\_ (Typical ratio is 4:1, or 80% cut to 20% tie)

Thickness Buildup = \_\_\_\_\_ in. / cm

---

**Note**



A cut-to-tie ratio that causes a thickness buildup greater than 0.025 in. / 0.0635 cm, or that creates an evenness variation greater than 0.003 in. / 0.00762 cm, will result in an unreliable and unpredictable form.

---

### Perforation Intersections

\_\_\_\_\_ Horizontal-vertical perforations are tie points. Cut points at such intersections are unacceptable.

### Chaff Content

\_\_\_\_\_ Tractor holes are clear of chaff.

\_\_\_\_\_ There is no loose chaff in the box the paper is packed in.

## Summary

---

Because it is impossible to test all possible forms available for use in the printer, Printronix recommends that paper conform to the specifications outlined in this appendix for the best printer performance.

But the guidelines in this appendix are not a substitute for actual testing. Always test forms—including special single-part paper, multipart forms, forms with glue strips, carbonless forms, card stock, and labels—for satisfactory feeding, registration, and print quality prior to purchase. For best results in selecting standard or specialty forms, consult a forms vendor who can ensure conformance to the guidelines in this appendix and who can recommend cost-effective purchases.

### Storage And Handling

---

The performance of the printer depends to a large degree on the condition of the paper used; therefore, the following principles for packaging, handling, and storage are recommended.

### Packaging

To avoid damage during handling, use top and bottom fillers in continuous form cartons to hold the paper stack firmly in place. Proper packaging ensures that the paper remains flat and is not damaged along the edges.

## **Storage**

Do not store cartons directly on the floor, and do not stack them more than six high. Set each carton upright and squarely on the one underneath. Do not place anything else on the stack of paper, because this can damage the paper.

## **Preconditioning Forms**

Protect paper from temperature and humidity extremes. Store paper in the same environment as the printer for 24 to 48 hours before using the paper. This allows the moisture content of the paper to stabilize.

LP Series and LineJet printers are used at temperatures from 5° to 40° C (41° to 104° F) up to 1524 meters (5000 feet), from 5° to 32° C (41° to 90° F) up to 2438 meters (8000 feet), with a non-condensing relative humidity of 10% to 90%. For best results, however, store the printer paper at 18° to 24° C (65° to 75° F), with a relative humidity of 40% to 50%.

If the printer is in an environment subject to extremes of temperature or humidity, store the printer paper in a better environment and move it to the printer as needed.





# C

## Standard ASCII Character Set

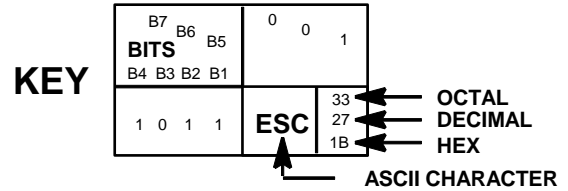

| BITS<br>B7 B6 B5<br>B4 B3 B2 B1 | ROW | COLUMN |                | 0             |                | 1  |                | 2 |                | 3 |                 | 4 |                 | 5 |                  | 6   |                  | 7 |   |
|---------------------------------|-----|--------|----------------|---------------|----------------|----|----------------|---|----------------|---|-----------------|---|-----------------|---|------------------|-----|------------------|---|---|
|                                 |     | 0      | 1              | 0             | 1              | 0  | 1              | 0 | 1              | 0 | 1               | 0 | 1               | 0 | 1                | 0   | 1                | 0 | 1 |
| 0 0 0 0                         | 0   | NUL    | 0<br>0<br>0    | DLE           | 20<br>16<br>10 | SP | 40<br>32<br>20 | 0 | 60<br>48<br>30 | @ | 100<br>64<br>40 | P | 120<br>80<br>50 | , | 140<br>96<br>60  | p   | 160<br>112<br>70 |   |   |
| 0 0 0 1                         | 1   | SOH    | 1<br>1<br>1    | DC1<br>(XON)  | 21<br>17<br>11 | !  | 41<br>33<br>21 | 1 | 61<br>49<br>31 | A | 101<br>65<br>41 | Q | 121<br>81<br>51 | a | 141<br>97<br>61  | q   | 161<br>113<br>71 |   |   |
| 0 0 1 0                         | 2   | STX    | 2<br>2<br>2    | DC2           | 22<br>18<br>12 | "  | 42<br>34<br>22 | 2 | 62<br>50<br>32 | B | 102<br>66<br>42 | R | 122<br>82<br>52 | b | 142<br>98<br>62  | r   | 162<br>114<br>72 |   |   |
| 0 0 1 1                         | 3   | ETX    | 3<br>3<br>3    | DC3<br>(XOFF) | 23<br>19<br>13 | #  | 43<br>35<br>23 | 3 | 63<br>51<br>33 | C | 103<br>67<br>43 | S | 123<br>83<br>53 | c | 143<br>99<br>63  | s   | 163<br>115<br>73 |   |   |
| 0 1 0 0                         | 4   | EOT    | 4<br>4<br>4    | DC4           | 24<br>20<br>14 | \$ | 44<br>36<br>24 | 4 | 64<br>52<br>34 | D | 104<br>68<br>44 | T | 124<br>84<br>54 | d | 144<br>100<br>64 | t   | 164<br>116<br>74 |   |   |
| 0 1 0 1                         | 5   | ENQ    | 5<br>5<br>5    | NAK           | 25<br>21<br>15 | %  | 45<br>37<br>25 | 5 | 65<br>53<br>35 | E | 105<br>69<br>45 | U | 125<br>85<br>55 | e | 145<br>101<br>65 | u   | 165<br>117<br>75 |   |   |
| 0 1 1 0                         | 6   | ACK    | 6<br>6<br>6    | SYN           | 26<br>22<br>16 | &  | 46<br>38<br>26 | 6 | 66<br>54<br>36 | F | 106<br>70<br>46 | V | 126<br>86<br>56 | f | 146<br>102<br>66 | v   | 166<br>118<br>76 |   |   |
| 0 1 1 1                         | 7   | BEL    | 7<br>7<br>7    | ETB           | 27<br>23<br>17 | '  | 47<br>39<br>27 | 7 | 67<br>55<br>37 | G | 107<br>71<br>47 | W | 127<br>87<br>57 | g | 147<br>103<br>67 | w   | 167<br>119<br>77 |   |   |
| 1 0 0 0                         | 8   | BS     | 10<br>8<br>8   | CAN           | 30<br>24<br>18 | (  | 50<br>40<br>28 | 8 | 70<br>56<br>38 | H | 110<br>72<br>48 | X | 130<br>88<br>58 | h | 150<br>104<br>68 | x   | 170<br>120<br>78 |   |   |
| 1 0 0 1                         | 9   | HT     | 11<br>9<br>9   | EM            | 31<br>25<br>19 | )  | 51<br>41<br>29 | 9 | 71<br>57<br>39 | I | 111<br>73<br>49 | Y | 131<br>89<br>59 | i | 151<br>105<br>69 | y   | 171<br>121<br>79 |   |   |
| 1 0 1 0                         | 10  | LF     | 12<br>10<br>0A | SUB           | 32<br>26<br>1A | *  | 52<br>42<br>2A | : | 72<br>58<br>3A | J | 112<br>74<br>4A | Z | 132<br>90<br>5A | j | 152<br>106<br>6A | z   | 172<br>122<br>7A |   |   |
| 1 0 1 1                         | 11  | VT     | 13<br>11<br>0B | ESC           | 33<br>27<br>1B | +  | 53<br>43<br>2B | ; | 73<br>59<br>3B | K | 113<br>75<br>4B | [ | 133<br>91<br>5B | k | 153<br>107<br>6B | {   | 173<br>123<br>7B |   |   |
| 1 1 0 0                         | 12  | FF     | 14<br>12<br>0C | FS            | 34<br>28<br>1C | ,  | 54<br>44<br>2C | < | 74<br>60<br>3C | L | 114<br>76<br>4C | \ | 134<br>92<br>5C | l | 154<br>108<br>6C |     | 174<br>124<br>7C |   |   |
| 1 1 0 1                         | 13  | CR     | 15<br>13<br>0D | GS            | 35<br>29<br>1D | -  | 55<br>45<br>2D | = | 75<br>61<br>3D | M | 115<br>77<br>4D | ] | 135<br>93<br>5D | m | 155<br>109<br>6D | }   | 175<br>125<br>7D |   |   |
| 1 1 1 0                         | 14  | SO     | 16<br>14<br>0E | RS            | 36<br>30<br>1E | .  | 56<br>46<br>2E | > | 76<br>62<br>3E | N | 116<br>78<br>4E | ^ | 136<br>94<br>5E | n | 156<br>110<br>6E | ~   | 176<br>126<br>7E |   |   |
| 1 1 1 1                         | 15  | SI     | 17<br>15<br>0F | US            | 37<br>31<br>1F | /  | 57<br>47<br>2F | ? | 77<br>63<br>3F | O | 117<br>79<br>4F | _ | 137<br>95<br>5F | o | 157<br>111<br>6F | DEL | 177<br>127<br>7F |   |   |



---

# D

## *Monitoring Printers*

---

### **Implementing Remote Management Software (RMS)**

---

Remote printer management includes the following tasks:

- Monitoring the status of network printers
- Responding to alarms
- Gathering statistics on printer operations

The three elements of network printer monitoring and management are:

- Agent/manager model
- MIB, the management information database
- SNMP, the protocol used to get management information

#### **Agent/Manager Model**

---

The elements of a monitoring system, MIB and SNMP, are implemented in an agent/manager model:

- The **manager** is a console, workstation, or server on working hubs or routers which has a global knowledge of NIC and printers. OpenView is a management console.
- **Agents** are utilities that reside on devices, such as a NIC, that respond through SNMP to management requests for information. The information is stored in a MIB (Management Information Base).

#### **MIB**

---

A MIB is a Management Information Base that contains information a device makes available to SNMP. The MIB describes information about actual objects to be managed, controlled, and viewed. There are many different MIBs defined.

#### **Standards of Network Printer MIBs**

The Printer MIB contained in the NIC is based on the following standards:

- System and Interfaces Group MIB (RFC 1213 of March 1991)
- Host Resource MIB (RFC 1514 of September 1993)
- Printer MIB (RFC 1759 of March 1995)

## Components of the Printer MIB

The printer MIB gives the network manager access to most of the information that is normally accessible through the NIC command set for configuring the server with SNMP. Some objects identified by this MIB are not applicable to the NIC.

The complete definition of the Printer MIB is provided in the Printer MIBs in DOS Format and Printer MIBs in TAR Format, which are shipped with the NIC. The MIB is provided in a subset of the ASN.1 syntax. The Printer MIB is composed of the following sections:

- General
- Cover
- Localization
- Input
- Output
- Marker
- Media Path
- Channel
- Interpreter
- Console
- Alert

## Information Provided by the MIB

The Printer MIB contains the following types of information about network printers:

**Descriptions.** Printer configuration, location, and contact.

**Status.** Current operating status of printers.

**Alerts.** Reportable events from printers.

## SNMP

---

SNMP is the network protocol used to communicate between manager and agent. Managers request information, usually through automated polling at specified intervals, and agents respond. Though used primarily on TCP/IP networks, SNMP can be implemented on other protocols, for example, IPX.

SNMP is a standard by which a network manager can get statistics and configuration information from the NICs and other devices on the network. This is done through a Network Management Station (NMS), such as OpenView and NetView®.

## Monitoring Tools

---

Many tools can be used to monitor printers with SNMP agents. One of these tools is NetView. There are also other MIB browsers, which are not described here.

### Monitoring With AIX NetView/6000

---

The AIX NetView/6000 program can manage any IP-addressable device with an SNMP agent.

NetView/6000 can be used to set a network topology, monitor a network, diagnose problems, and measure network performance.

Through its MIB Browser, information about the resources affecting an event (such as an alarm) can be obtained.

### Monitoring With Web JetAdmin

---

Web JetAdmin (version 6.x) can monitor IP addressable devices containing the printer MIB.

### OS/2 TCP/IP

---

To get SNMP.EXE to work correctly to browse MIB items, you may need to delete the following file:

```
d:\mptn\etc\mib2.tbl
```

### Setting The SNMP Community Name

---

The default SNMP read-only community name is "public" and cannot be changed.

Change the SNMP R/W community name with the command:

```
set user passwd snmp com_name
save
```

where *com\_name* is the new SNMP R/W community name.

The default is no R/W community name.

---

**Note**

Changing SNMP community names or access rights may hinder or disable applications that are monitoring your printers.

---

## **Reference**

For further information on SNMP and MIB, refer to the following:

- RFC 1155 — Structure and Identification of Management Information for TCP/IP-based Internets (SMI)
- RFC 1156 — Management Information Base for Management of TCP/IP Internets (MIB)
- RFC 1157 — A Simple Network Management Protocol (SNMP)
- The Simple Book: An Introduction to Management of TCP/IP-based Internets

## **Getting the Latest MIB Information**

To obtain the latest copy of these and other RFCs, FTP the files from one of the following two sources:

Internet:

**ftp.isi.edu**

World Wide Web:

**<http://www.ietf.org/rfc.html>**

---

# Index

## Symbols

? Command, 243

## Numerics

10/100Base-T

Novell Host configuration, 229

Troubleshooting, 236

15V PWR FAIL \* message, 283

20 CPI Condensed, 94, 96

23.5V PWR FAIL \* message, 283

48V PWR FAIL \* message, 283

8.5V PWR FAIL \* message, 283

## A

A TO D OVERUN \* message, 283

Absorb After ^PN, 111

Absorb after ^PY, 110

Access Lists, TCP, 261

Access Methods, Command Shell, 243

ACCESS NULL PTR \* message, 283

Acknowledge signal, 267

Active Emulation Menu, 79

Administration, configuration, 154

AIX NetView/6000, 317

Alert groups, 151

Aliases, 158

All Black, 130

All E's, 130

All H's, 130

All Underlines, 130

Alt. Set 80-9F, 92

Alternate Character Set, 94

Alternate Set 80-9F, 97, 98

Append Rotated, 109

ASCII Character Set, 313

Auto LF, 91, 94, 96, 98, 100

Auto Switching, 123

Auto Switching Submenu, 123

Auto Switching, 123

Port Type, 123

Report Status, 124

Timeout, 124

Trickle Time, 124

Auto Uppercase, 104

Autoport Switching, 265

Autowrap, 103

## B

Banner Page, 147

Banner Page, Print Path, 146

Barcode Errors, 112

Baud Rate, 120

Bindery PSERVER Setup (Netware 3.x, 4.x and 5.x), 231

Bi-Tronics interface, 268

Negotiation phase, 269

operating modes, 268

signals, 269

Bi-Tronics submenu, 116

Buffer Size in K, 117

Prime Signal, 116

TOF Action, 117

BSD Systems, LPR/LPD print setup, 200

BUFFER OVERRUN message, 283

Buffer Size in K, 117, 119, 121, 122

Burnin Test, 131

Busy on Strobe, 118

Busy signal, 267

Byte mode, 268

---

## C

- Cautions, 17
- Centronics
  - configuration, 267
  - interface signals, 267
  - Parallel Interface, 266
- Centronics (Parallel) submenu, 117
  - Buffer Size in K, 119
  - Busy on Strobe, 118
  - Data Bit 8, 118
  - Data Polarity, 118
  - Latch Data On, 118
  - PI Ignored, 118
  - Prime Signal, 118
  - Resp. Polarity, 118
  - TOF Action, 119
- Chaff content, 307
- Changing parameter settings, 49
- Changing parameters, 54
- Character Set, 92, 94, 96, 98
  - ASCII, 313
- Cleaning
  - exterior, 275
  - interior, 275
- Clear Error Log, 131
- CLEAR PAPER JAM message, 283
- Clear to send (CTS) signal
  - RS-232 serial interface, 272
- CLEARING PROGRAM FROM FLASH, 42, 44, 283, 286
- CLOSE PLATEN message, 283
- COIL HOT, 283
- Command Help, 243
  - ?, 243
- Command Prefixes, 244
- Command Shell
  - Access Methods, 243
  - Getting Command Help, 243
  - Main Command Shell Prefixes, 243
  - overview, 243
- Command, complete list, 244
- Commands
  - debug, 255
  - list, 254
  - miscellaneous, 256
  - set, 247
  - Store, 244
- Communicating, Windows, 177
- Compatibility mode, 268
- Compress CPI, 105
- Compressed Print, 101
- Configuration
  - administration, 154
  - Centronics parallel interface, 267
  - deleting, 64
  - HP e3000/NIC, 165
  - I/O Port, 149
  - loading values, 60
  - Log Path, 148
  - NPDS, 234
  - power-up, 62
  - print, 58
  - Print Model, 147
  - protecting, 66
  - RS-232 serial interface, 274
  - RS-422 serial interface, 274
  - save, 56
  - SNMP, 150
  - System, 155
  - TCP/IP NIC, 157
- Configuration Control Menu, 77
  - Delete Configuration, 78
  - Load Configuration, 77
  - Power-Up Configuration, 78
  - Print Configuration, 78
  - Protect Configuration, 78
  - Save Configuration, 78
- Configuration Main Menu, 74
- Configuration Menus, overview, 73
- Configuration network, 143
- Configuration Print Path, 145
  - Destination settings, 145
- Configuration Printout, 84
- Configuration setup, NIC, 67



---

- Configurations, 48
- Configuring printer, 45
- Configuring the printer, 45
- Connection to network, 67
- Control Code 06, 91, 97, 100
- Control Code 08, 91
- Control panel, 45
- Control panel configuration
  - gateway address, 68
  - IP Address, 68
  - subnet mask, 68
- Convert to U/C, 111
- CPI/LPI Select, 87
- CR Edit, 103
- CTL VOLT FAIL \* message, 283

## D

- Data Bit 8, 112, 118
- Data carrier detect (DCD) signal, RS-232 serial interface, 273
- Data lines 1 through 8 signal, 267
- Data Polarity, 118
- Data Protocol, 120
- Data set ready (DSR) signal, RS-232 serial interface, 272
- Data strobe signal, 267
- Data Term Ready, 121
- Data Terminal Ready (DTR) signal, RS-232 serial interface, 273
- Debug Commands, 255
- Default configuration values, factory, 50
- Define CR Code, 91, 93, 96, 97, 100, 103
- Define LF Code, 91, 94, 96, 98, 101, 103
- Definitions, 303
- Delete Configuration, 78
- Deleting configurations, 64
- Destination names, changing, 178
- Destination settings
  - Back Channel, 145
  - Name, 145
  - Services, 145
- Diagnosing problems, 278
- Diagnostic tools, 22

- Diagnostic, tests, 278
- Diagnostics Menu, 129
  - Paper Out Dots, 131
  - Print Statistics, 132
  - Printer Tests, 130
  - System Memory, 131
  - Test Width, 131
- DIAGNOSTICS PASSED, 42, 283
- Dimensions, printer, 294
- Display Function, 83
- Display Language, 114
- Downloading
  - function code, 29
  - optional font files, 39
  - preparation, 30
  - to flash memory, 39
- DRVR CIR BAD \* message, 283

## E

- E's + TOF, 130
- Electrical characteristics, 295
- Elong/Alt. Font, 101
- E-mail alert posting, 150
- Emulation Menu, 80
  - LP Plus Emulations, 80
  - Optional Emulations, 80
  - PCL -II Emulation, 81
  - PCL-II Emulation, 80
- Emulations, 23
  - downloading software through serial or parallel port, 33
  - installing, 32
  - printer, 21
- Energy Star, 295
- E-Net Test Page, 131
- ENTER key
  - locking, 48
  - unlocking, 48
- Environment Description, Windows, 175
- Environmental characteristics, 294
  - Energy Star, 295
  - relative humidity, 294
- Environmental considerations, 305

Epson FX Emulation, 95  
 20 CPI Condensed, 96  
 Alternate Set 80-9F, 97  
 Auto LF, 96  
 Character Set, 96  
 Define CR Code, 96  
 Define LF Code, 96  
 Printer Select, 96

**ERROR**  
 DC PROGRAM NOT VALID, 42, 284  
 DRAM AT ADDRESS XXXXXXXX, 284  
 EC PROGRAM NOT VALID, 42, 284  
 EC STOPPED AT STATE XXXX, 42, 284  
 FLASH NOT DETECTED, 42, 284  
 NO DRAM DETECTED, 42  
 NVRAM FAILURE, 42, 284  
 PROGRAM NEEDS MORE DRAM, 42  
 PROGRAM NEEDS MORE FLASH, 43  
 PROGRAM NOT COMPATIBLE, 43  
 PROGRAM NOT VALID, 43  
 SECURITY PAL NOT DETECTED, 43  
 SHORT AT ADDRESS XXXX, 43  
 WRITING TO FLASH, 42, 43  
 WRONG CHECKSUM, 43

Error handling, 111  
 RS-232 serial interface, 273  
 RS-422 serial interface, 273

Error Markers, 111

Error messages See Fault messages, 282

Error Msgs, 111

ERROR NO DRAM DETECTED, 284  
 ERROR OCCURRED / FLUSHING QUEUES\*, 43  
 ERROR PROGRAM NEEDS MORE DRAM, 284  
 ERROR PROGRAM NEEDS MORE FLASH, 284  
 ERROR PROGRAM NOT COMPATIBLE, 284  
 ERROR PROGRAM NOT VALID, 284

Error Report, 106

ERROR SECURITY PAL NOT DETECTED, 284  
 ERROR SHORT AT ADDRESS XXXX, 284  
 ERROR WRITING TO FLASH, 284, 285  
 ERROR WRONG CHECKSUM, 285

ESC d Command, 98

ETHERNET ADAPTER BEING INITIALIZED  
 message, 285

ETHERNET DETECTED message, 285

ETHERNET PARAMETERS menu  
 Ethernet speed, 127  
 Gateway address, 126  
 IP address, 125  
 MAC address, 126  
 NetBIOS protocol, 126  
 Novell frame, 126  
 Novell protocol, 126  
 Subnet mask, 126

Ethernet Params Menu, 125

Ethernet speed, Ethernet Parameters menu, 127

Ethernet Submenu, 122  
 Buffer Size in K, 122

EVFU Select, 92, 101

EXHAUST FAN FLT message, 285

Exterior cleaning, 275

## **F**

Face, CPI Delay, 83

Factory default configuration values, 50

Fault messages, 282  
 15V PWR FAIL \*, 283  
 23.5V PWR FAIL \*, 283  
 48V PWR FAIL \*, 283  
 8.5V PWR FAIL \*, 283  
 A TO D OVERUN \*, 283  
 ACCESS NULL PTR \*, 283  
 BUFFER OVERRUN, 283  
 CLEAR PAPER JAM, 283  
 CLOSE PLATEN, 283  
 COIL HOT, 283  
 CTL VOLT FAIL \*, 283  
 DRVR CIR BAD \*, 283  
 ETHERNET ADAPTER BEING  
 INITIALIZED, 285  
 ETHERNET DETECTED, 285  
 EXHAUST FAN FLT, 285  
 FIRMWARE ERROR, 285  
 FRAMING ERROR, 285  
 HAM. COIL OPEN \*, 285

---

HAMMER COIL BAD X, X, X, 285  
 HB NOT INSTALLED \*, 285  
 ILL EXT BUS ACC \*, 286  
 ILL INST ACCSS \*, 286  
 ILLGL OPR ACCSS \*, 286  
 INTAKE FAN FAULT, 286  
 LO DRV. SHORT \*, 286  
 LOAD PAPER, 286  
 PAP BAD TABLE \*, 286  
 PAP BSY TOO LNG \*, 286  
 PAP FIFO OVERFL \*, 286  
 PAP FIFO UNDRFL \*, 286  
 PAP ILLGL ST \*, 287  
 PAP INCMPL ENER \*, 287  
 PAP INVLD CMD \*, 287  
 PAP INVLD PARM \*, 287  
 PAP NOT SCHED \*, 287  
 PAP NT AT SPEED \*, 287  
 PAP UNEXP INT \*, 287  
 PARITY ERROR, 287  
 PLAT INV CMD \*, 287  
 PLAT INV PARM \*, 287  
 PLAT INV STATE \*, 287  
 POWER SAVER MODE, 287  
 POWERSUPPLY HOT \*, 287  
 PRINTER HOT \*, 287  
 PROTECTED INSTR \*, 287  
 PWRSUPP VOLT \*, 287  
 RIB INVLD CMD \*, 288  
 RIB INVLD STAT \*, 288  
 RIBBON DRIVE, 288  
 RIBBON INK OUT CHANGE RIBBON, 288  
 SECURITY CODE VIOLATION, 288  
 SHUTL INV CMD \*, 288  
 SHUTL INV PARM \*, 288  
 SHUTTLE JAM, 288  
 SOFTWARE ERROR \*, 288  
 STACK OVERFLOW \*, 288  
 STACK UNDERFLOW \*, 289  
 STACKER FAULT, 289  
 STACKER FULL, 289  
 STACKER JAM, 289  
 TCB CORRUPTED \*, 289  
 UNDEF INTERRUPT \*, 289  
 UNDFNED OPCODE \*, 289  
 UP DRV. SHORT \*, 289  
 WAITING FOR ETHERNET ADAPTER, 289  
 FF Valid at TOF, 94  
 File Server, Novell Network, 144  
 Filter, Print Model, 147  
 Filter, Print Path, 146  
 FIRMWARE ERROR message, 285  
 Flash messages  
     CLEARING PROGRAM FROM FLASH, 42,  
         44, 283, 286  
     DIAGNOSTICS PASSED, 42, 283  
     ERROR  
         DC PROGRAM NOT VALID, 42, 284  
         DRAM AT ADDRESS XXXXXXXX, 284  
         EC PROGRAM NOT VALID, 42, 284  
         EC STOPPED AT STATE XXXX, 42, 284  
         FLASH NOT DETECTED, 42, 284  
         NO DRAM DETECTED, 42  
         NVRAM FAILURE, 42, 284  
         PROGRAM NEEDS MORE DRAM, 42  
         PROGRAM NEEDS MORE FLASH, 43  
         PROGRAM NOT COMPATIBLE, 43  
         PROGRAM NOT VALID, 43  
         WRITING TO FLASH, 42  
     ERROR NO DRAM DETECTED, 284  
     ERROR OCCURRED / FLUSHING  
         QUEUES\*, 43  
     ERROR PROGRAM NEEDS MORE  
         DRAM, 284  
     ERROR PROGRAM NEEDS MORE  
         FLASH, 284  
     ERROR PROGRAM NOT COMPATIBLE, 284  
     ERROR PROGRAM NOT VALID, 284  
     ERROR SECURITY PAL NOT  
         DETECTED, 284  
     ERROR SHORT AT ADDRESS XXXX, 284  
     ERROR WRITING TO FLASH, 284, 285  
     ERROR WRONG CHECKSUM, 285  
     ERROR, DRAM AT ADDRESS  
         XXXXXXXX, 42

ERROR, SECURITY PAL NOT  
DETECTED, 43  
ERROR, SHORT AT ADDRESS XXXX, 43  
ERROR, WRITING TO FLASH, 43  
ERROR, WRONG CHECKSUM, 43  
LOADING PROGRAM FROM PORT  
XX%, 43, 286  
PLEASE WAIT... RESET IN PROGRESS, 44  
RESETTING . . . / PLEASE WAIT, 288  
RESTORING BOOT CODE, 44, 288  
SECURITY CODE VIOLATION, 44  
SENDING PROGRAM TO EC  
PROCESSOR, 44, 288  
TABLE MISMATCH / DOWNLOAD AGAIN, 44  
TABLE MISMATCH DOWNLOAD AGAIN, 289  
Font Attributes, 87  
Form design checklist, 308  
    chaff content, 310  
    Cut-To-Tie Ratio, 310  
    environment, 308  
    form evenness, 309  
    form thickness, 308  
    form weight, 308  
    methods of forms attachment, 309  
    perforation intersections, 310  
    tractor pin holes, 309  
    type of form, 308  
Form evenness, 305  
Form thickness, 305  
Form types, 305  
Form weight, 305  
Forms attachment, methods, 306  
Frame Type, changing, 225  
FrameType, Novell Network, 144  
FRAMING ERROR message, 285  
Free Format, 109  
FTP Printing, 201  
Function code  
    copy to computer, 31  
    downloading, 29  
    loading to flash memory, 32

## G

Gateway Address, control panel configuration, 68  
Gateway address, Ethernet Parameters menu, 126  
Graphics Density, 83  
Graphics formatting, 22  
Graphics Options, 109  
Graphics options, 23  
Guidelines, paper, 303

## H

HAM. COIL OPEN \* message, 285  
HAMMER COIL BAD X, X, X message, 285  
Handling, 310  
HB NOT INSTALLED \* message, 285  
Header String, Print Model, 147  
Header String, Print Path, 146  
Help, Command, 243  
Hex code printout, 280  
Hex Dump Mode, 114  
High Speed Print, 101  
Host configuration  
    Novell, 208  
    Unix, 196  
Host Interface Menu, 115  
Host Setup, Windows 3.1, 187  
HP e3000 / MPE-XL / MPE / iX  
    DTC Configuration, 173  
    Host Configuration, 165  
HP e3000/NIC Configuration, 165  
HP-UX, Print setup, 196  
HTML forms, 207

## I

I/O Port  
    configuration, 149  
    Parallel port (PRN), 149  
    status, 155  
Ignore Char, 105  
Ignore Dots, 109  
Ignore Mode, 108  
Ignore Nulls, 112  
Ignore Spaces, 110  
Ignore/DB8 Setup, 112

---

- IGP/PGL Emulation, 102
  - Auto Uppercase, 104
  - Autowrap, 103
  - Compressed CPI, 105
  - CR Edit, 103
  - Define CR Code, 103
  - Define LF Code, 103
  - Error Report, 106
  - Ext Execute Copy, 105
  - Ignore Char, 105
  - IGP100 Compatibility, 106
  - Optimized Ratio, 106
  - PI Slew Range, 103
  - Power on IGP/PGL, 104
  - Select Font, 104
  - Select LPI, 104
  - Select SFCC, 103
  - Skip Cmd Prefix, 104
  - UPC Descenders, 105
- IGP/VGL Emulation, 107
  - Absorb After ^PN, 111
  - Absorb after ^PY, 110
  - Append Rotated, 109
  - Barcode Errors, 112
  - Convert to U/C, 111
  - Data Bit 8, 112
  - Error Handling, 111
  - Error Markers, 111
  - Error Msgs, 111
  - Free Format, 109
  - Graphics Options, 109
  - Ignore Dots, 109
  - Ignore Mode, 108
  - Ignore Nulls, 112
  - Ignore Spaces, 110
  - Ignore/DB8 Setup, 112
  - IGP110 Compatbl., 111
  - ISO Character Set, 113
  - LPI, 109
  - Mgnum Conversion, 109
  - Midline PY, 111
  - Offpage Errors, 112
  - PI Control, 113
  - Rot. Char Size, 110
  - SFCC, 108
  - SFCC & Pwrap, 108
  - Slashes in Zeros, 109
  - Truncate Alpha, 110
  - UPC Descenders, 110
- IGP100 Compatibility, 106
- IGP110 Compatbl., 111
- ILL EXT BUS ACC \* message, 286
- ILL INST ACCSS \* message, 286
- ILLGL OPR ACCSS \* message, 286
- INTAKE FAN FAULT message, 286
- Interface
  - Bi-Tronics, 268
  - Centronics, 266
  - RS-232 serial, 271
  - specifications, 296
  - type, 120
- Interface, overview, 265
- Interfaces, 21
- Interior cleaning, 275
- IP Address, control panel configuration, 68
- IP address, Ethernet Parameters menu, 125
- ISO Character Set, 113

**L**

- Latch Data On, 118
- Line matrix printing, 24
- Line Terminator, 83
- LinePrinter Plus Emulation, 86
  - CPI/LPI Select, 87
  - Font Attributes, 87
  - Page Format, 88
  - Print Character Set, 87
  - Printer Protocol, 87
  - Reset Cmd CFG Ld, 89
- List Commands, 254
- LO DRV. SHORT \* message, 286
- Load Configuration, 77
- LOAD PAPER message, 286
- Loading configuration values, 60
- LOADING PROGRAM FROM PORT XX%, 43, 286

---

Log Path  
    configuration, 148  
    Logpath Port, 149  
    Logpath Type, 148  
    Name, 148  
Log Path Port, Print Path, 147  
Log Path Type, Print Path, 147  
Logging, printer, 262  
Logical Printer Architecture, 138  
    Destinations/Queues, 139  
    Models, 140  
Logpath Port, Log Path, 149  
Logpath Type, Log Path, 148  
Logpaths, logging printer, 263  
LP Plus Emulations, 80  
LPI, 109  
LPI Adjust, 84  
LPR/LPD, Print setup on BSD Systems, 200

## M

MAC address, Ethernet Parameters menu, 126  
Maint/Misc Menu, 114  
    Display Language, 114  
    Hex Dump Mode, 114  
    Power Stacker, 115  
    Power-up State, 114  
Maintenance, 275  
Manual  
    cautions, 17  
    notes, 17  
    printing conventions, 17  
    related documents, 18  
    warnings, 17  
Maximum Line Width, 83  
Menu  
    Configuration Control, 77  
    Diagnostics, 129  
    Epson FX Emulation, 95  
    Ethernet Params, 125  
    Host Interface, 115  
    IGP/PGL Emulation, 102  
    IGP/VGL Emulation, 107  
    LinePrinter Plus Emulation, 86

Main, 74  
Maint/Misc, 114  
Printer Control, 127  
P-Series Emulation, 90  
P-Series XQ Emulation, 100  
RibbonMinder, 132  
    Serial Matrix Emulation, 97  
Mgnum Conversion, 109  
MIB, 315  
Midline PY, 111  
Miscellaneous Commands, 256  
Model Type, Print Model, 147  
Model Type, Print Path, 146  
models, setting onlcr, 203  
Monitoring tools, 317  
    AIX NetView/6000, 317  
    OS/2 TCP/IP, 317  
    setting SNMP community name, 317  
    Web JetAdmin, 317  
Monitoring, printer, 262

## N

Name, Log Path, 148  
Name, Print Model, 147  
Naming scheme, 264  
NDS  
    setting NIC content, 227  
    setting print server preferred NDS tree, 228  
NDS & Bindery  
    change print server mode, 226  
    changing Frame Type, 225  
    changing print server name, 223  
    password security, 221  
    Polling time, 222  
    Preferred File Server, 218  
NDS PSERVER Setup (Netware 4.x and 5.x), 229  
NDS, Novell Network, 144  
Negotiation phase, 269  
NetBIOS protocol, Ethernet Parameters menu, 126  
NetBIOS TCP/IP  
    Windows Network, 144  
    Workgroup Name, 144

---

- Netware 3.x, 4.x, and 5.x
  - Bindery PSERVER Setup, 231
  - Bindery Queue in NDS, 231
  - PPRINTER/NPRINTER Setup, 232
- Netware 4.x and 5.x, NDS PSERVER Setup, 229
- NetWare Version 4.x and 5.x
  - Novell, 211, 213
- Network
  - configuration, 143
  - status, 155
  - TCP/IP, 143
- Network connection, 67
- Network Interface Card (NIC), 26
- Network printing overview, 137
- New Rib. Detect, 136
- New Ribbon, 133
- Nibble mode, 268
- NIC
  - configuration setup, 67
  - downloading software, 37
  - naming scheme, 264
  - Reset mode, 27
  - Run mode, 27
  - setting content, 227
  - Windows configuration, 176
- NIC Configuration Verification, 168
- NIC Security, 259
  - guest, 259
  - passwords, 259
  - root, 259
  - users, 259
- NIC Web page
  - configuration, 142
  - overview, 141
- Notes, 17
- Novell
  - Environment description, 206
  - Host configuration, 208
  - Host configuration (10/100Base-T), 229
  - HTML forms, 207
  - NetWare Version 3.x PSERVER Setup, 208
  - NetWare Version 3.x RPRINTER Setup, 210
  - NetWare Version 4.x and 5.x, 211, 213
  - NIC configuration, 206
  - NIC Configuration (10/100Base-T), 217
  - Troubleshooting Tips, 215
- Novell 4.x and 5.x, troubleshooting, 216
- Novell Configuration for 10/100Base-T, overview, 217
- Novell configuration, overview, 205
- Novell frame, Ethernet Parameters menu, 126
- Novell Network, 144
  - File Server, 144
  - FrameType, 144
  - NDS, 144
  - Protocol, 144
  - Pserver, 145
  - Rprinter, 145
  - Service Type, 144
- Novell protocol, Ethernet Parameters menu, 126
- NPDS configuration, 234

**O**

- Offpage Errors, 112
- onlcr, 203
- Online signal, 267
- Open Platen @ BOF, 128
- Operating modes, 48
- Optimized Ratio, 106
- Optional Emulations, 80
- Optional Fonts, downloading to flash memory, 39
- OS/2 TCP/IP, 317
- Output control, 22
- Overrun error handling, 273
- Overstrike, 91, 98

**P**

- P5000LJ Series Printer Family, 19
  - Page level recovery, 171
  - supplies, 293
- Page Format, 88
- Page Length Adjust/Inches, 84
- Page Length Adjust/Lines, 84
- Page Length Representation, 83
- Page level recovery, 171
- PAP BAD TABLE \* message, 286
- PAP BSY TOO LNG \* message, 286

---

PAP FIFO OVERFL \* message, 286  
PAP FIFO UNDRFL \* message, 286  
PAP ILLGL ST \* message, 287  
PAP INCMPL ENER \* message, 287  
PAP INVLD CMD \* message, 287  
PAP INVLD PARM \* message, 287  
PAP NOT SCHED \* message, 287  
PAP NT AT SPEED \* message, 287  
PAP UNEXP INT \* message, 287  
Paper  
    adjusting position, 170  
    guidelines, 303  
    specifications, 301  
Paper empty (PE) signal, 267  
Paper instruction (PI) signal, 267  
Paper Out Dots, 131  
Paperout Adj., 131  
Parallel port (PRN), I/O Port, 149  
Parameter settings  
    changing, 49  
    saving, 49  
Parameters, changing, 54  
Parity, 121  
PARITY ERROR message, 287  
Parity, error handling, 273  
Password security, setting, 221  
Passwords, 154  
PCL -II Emulation, 80  
    Configuration Printout, 84  
    Display Functions, 83  
    Face, CPI Delay, 83  
    Graphics Density, 83  
    Line Terminator, 83  
    LPI Adjust, 84  
    Maximum Line Width, 83  
    Page Length Adjust/Inches, 84  
    Page Length Adjust/Lines, 84  
    Page Length Representation, 83  
    Perforation Skip, 83  
    Primary Character Set, 82  
    PTX Linefeed, 84  
    Reset Cmd CFG Ld, 85  
    Secondary Character Set, 82  
    Symbol Set Print, 85  
Peer to peer networks, 137  
Perforation Skip, 83  
Phase Printer, 130  
PI Control, 113  
PI Ignored, 118  
PI Slew Range, 103  
Pin assignments  
    RS-232 serial interface, 272  
    RS-422 serial interface, 272  
PLAT INV CMD \* message, 287  
PLAT INV PARM \* message, 287  
PLAT INV STATE \* message, 287  
PLEASE WAIT... RESET IN PROGRESS, 44  
PMD (Paper Motion Detection) Fault, 128  
Polling time, adjusting, 222  
Port Type, 123  
Power on IGP/PGL, 104  
POWER SAVER MODE message, 287  
Power Saver Time, 129  
Power Stacker, 115  
POWERSUPPLY HOT \* message, 287  
Power-Up Configuration, 78  
Power-up configuration, 62  
Power-up State, 114  
Preferred File Server, 218  
Prefixes, Command, 244  
Primary Character Set, 82  
Prime Signal, 116, 118  
Print Character Set, 87  
Print Configuration, 78  
Print current configuration, 58  
Print Error Log, 131  
Print job servers, 138  
Print Model, 147  
    Banner Page, 147  
    configuration, 147  
    Filter, 147  
    Header String, 147  
    Model Type, 147  
    Name, 147



---

- Printer Configuration, 148
- Trailer String, 148
- Print Path
  - Banner Page, 146
  - Filter, 146
  - Header String, 146
  - Log Path Port, 147
  - Log Path Type, 147
  - Model Type, 146
  - Printer Configuration, 146
  - Selected Log Path, 146
  - Selected Model, 146
  - Trailer String, 146
- Print Path, configuration, 145
- Print server
  - change mode, 226
  - changing name, 223
  - setting preferred NDS tree, 228
- Print setup
  - HP-UX, 196
  - Sys V, 198
- Print Statistics, 132
- Printer
  - architecture, 19
  - built-in diagnostic tools, 22
  - cleaning, 21
  - configuration, 45
  - dimensions, 294
  - emulations, 21, 23
  - features, 21
  - graphics formatting, 22
  - graphics options, 23
  - handling, 310
  - installing printer emulations, 32
  - interfaces, 21
  - line matrix printing, 24
  - loading function code to flash memory, 32
  - locking the ENTER key, 48
  - logging, 262
  - logging through logpaths, 263
  - monitoring, 262
  - monitoring tools, 317
  - operating modes, 48
  - output control, 22
  - predefined configurations, 48
  - protocols, 23
  - Remote Management Software, 315
  - ribbon specifications, 291
  - SNMP, 316
  - storage, 310
  - unlocking the ENTER key, 48
  - vertical formatting, 22
- Printer Configuration, Print Model, 148
- Printer Configuration, Print Path, 146
- Printer Control Menu, 127
  - Open Platen @ BOF, 128
  - PMD (Paper Motion Detection) Fault, 128
  - Power Saver Time, 129
  - Slow Paper Slew, 128
  - Unidirectional, 128
- PRINTER HOT \* message, 287
- Printer Protocol, 87
- Printer Select, 96, 98
- Printer settings, changing, 45
- Printer Tests, 130
  - All Black, 130
  - All E's, 130
  - All H's, 130
  - All Underlines, 130
  - Burnin Test, 131
  - Clear Error Log, 131
  - E's + TOF, 130
  - E-Net Test Page, 131
  - Paperout Adj., 131
  - Phase Printer, 130
  - Print Error Log, 131
  - Shift Recycle, 130
  - Shuttle Fast, 130
  - Shuttle Only, 130
  - Shuttle Slow, 130
- Printing conventions, 17
- Printing speed, 25
- Printouts, hex code, 280
- Problems, diagnosing, 278

---

Proprinter XL Emulation, 93  
    20 CPI Condensed, 94  
    Alternate Character Set, 94  
    Auto LF, 94  
    Character Set, 94  
    Define CR Code, 93  
    Define LF Code, 94  
    FF Valid at TOF, 94  
Protect Configuration, 78  
PROTECTED INSTR \* message, 287  
Protecting configurations, 66  
Protocol, Novell Network, 144  
Protocols, 23  
    RS-232 serial interface, 273  
    RS-422 serial interface, 273  
P-Series Emulation, 90  
    Alt. Set 80-9F, 92  
    Auto LF, 91  
    Character Set, 92  
    Control Code 06, 91  
    Control Code 08, 91  
    Define CR Code, 91  
    Define LF Code, 91  
    EVFU Select, 92  
    Overstrike, 91  
    Select SFCC, 92  
    SFCC d Command, 92  
P-Series XQ Emulation, 100  
    Auto LF, 100  
    Compressed Print, 101  
    Control Code 06, 100  
    Define CR Code, 100  
    Define LF Code, 101  
    Elong/Alt. Font, 101  
    EVFU Select, 101  
    High Speed Print, 101  
    Slew Relative, 102  
    Upper Case Select, 101  
Pserver, Novell Network, 145  
PTX Linefeed, 84  
PWRSUPP VOLT \* message, 287

## R

Received data (RD) signal  
    RS-232 serial interface, 272  
    RS-422 serial interface, 273  
Referencing A Bindery Queue In NDS (Netware 3.x, 4.x, and 5.x), 231  
Related documents, 18  
Relative humidity, 294  
Remote Management Software, 315  
    Agent/Manager Model, 315  
    MIB, 315  
Remote shell printing, 201  
Report Status, 124  
Request to Send, 121  
Request To Send (RTS) signal, RS-232 serial interface, 272  
Reset Cmd CFG Ld, 85, 89  
Reset mode, 27  
RESETTING . . . / PLEASE WAIT, 288  
Resp. Polarity, 118  
RESTORING BOOT CODE, 44, 288  
RIB INVLD CMD \* message, 288  
RIB INVLD STATE \* message, 288  
Ribbon Action, 133  
RIBBON DRIVE message, 288  
Ribbon End Point, 135  
RIBBON INK OUT CHANGE RIBBON message, 288  
Ribbon specifications, 291  
Ribbon Type, 135  
RibbonMinder Menu, 132  
    New Rib. Detect, 136  
    New Ribbon, 133  
    Ribbon Action, 133  
    Ribbon End Point, 135  
    Ribbon Type, 135  
Rot. Char Size, 110  
Routers  
    Unix, 195  
    Windows, 177  
Rprinter, Novell Network, 145

---

RPRINTER/NPRINTER Setup (Netware 3.x, 4.x, and 5.x), 232

RS-232 serial interface, 271

clear to send (CTS), 272

configuration, 274

data carrier detect (DCD), 273

data set ready (DSR), 272

error handling, 273

framing error handling, 273

overrun error handling, 273

parity error handling, 273

pin assignments, 272

protocol, 273

request to send (RTS), 272

X-ON/X-OFF signal, 273

RS-232 serial interface signals

data terminal ready (DTR), 273

received data (RD), 272

transmitted data (TD), 272

RS-422 serial interface

configuration, 274

error handling, 273

framing error handling, 273

overrun error handling, 273

parity error handling, 273

pin assignments, 272

X-ON/X-OFF signal, 273

RS-422 serial interface signals, 272

received data (RD), 273

transmitted data (TD), 273

Run mode, 27

## S

Save Configuration, 78

Save current configuration, 56

Saving parameter settings, 49

Secondary Character Set, 82

SECURITY CODE VIOLATION, 44

SECURITY CODE VIOLATION message, 288

Security, NIC, 259

Select Font, 104

Select LPI, 104

Select SFCC, 92, 103

Selected Log Path, Print Path, 146

Selected Model, Print Path, 146

Self-tests, running, 278

SENDING PROGRAM TO EC

PROCESSOR, 44, 288

Serial interface, RS-232, 271

Serial Matrix Character Set Menu, 99

Serial Matrix Emulation, 97

Alternate Set 80-9F, 98

Auto LF, 98

Character Set, 98

Control Code 06, 97

Define CR Code, 97

Define LF Code, 98

ESC d Command, 98

Overstrike, 98

Printer Select, 98

Serial Submenu, 119

Baud Rate, 120

Buffer Size in K, 121

Data Protocol, 120

Data Term Ready, 121

Interface Type, 120

Parity, 121

Request to Send, 121

Stop Bits, 121

Word Length, 121

Service Type, Novell Network, 144

Service, routine, 275

Set Commands, 247

SFCC, 108

SFCC & Pwrup, 108

SFCC d Command, 92

Shell commands, 243

Shift Recycle, 130

SHUTL INV CMD \* message, 288

SHUTL INV PARM \* message, 288

Shuttle Fast, 130

SHUTTLE JAM message, 288

Shuttle Only, 130

Shuttle Slow, 130

## Signals

- Bi-Tronics interface, 269
- Centronics parallel interface, 267
- RS-232 serial interface, 272
- RS-422 serial interface, 272

Slashes in Zeros, 109

Slew Relative, 102

Slow Paper Slew, 128

SNMP, 316

- configuration, 150
- manager alert posting, 150
- setting community name, 317

SOFTWARE ERROR \* message, 288

Software, downloading through the NIC, 37

Specifications

- electrical, 295
- environmental, 294
- interfaces, 296
- paper, 301
- ribbon, 291

Speed, printing, 25

STACK OVERFLOW \* message, 288

STACK UNDERFLOW \* message, 289

STACKER FAULT message, 289

STACKER FULL message, 289

STACKER JAM message, 289

Standard printer features, 21

Status

- I/O Port, 155
- menu, 155
- Network, 155

Stop Bits, 121

Storage, 310

Store Commands, 244

Subnet Mask, control panel configuration, 68

Subnet mask, Ethernet Parameters menu, 126

Supplies, P5000LJ, 293

Symbol Set Print, 85

Sys V, Print setup, 198

Syslog alert posting, 150

## System

configuration, 155

information, 154

System Memory, 131

## T

TABLE MISMATCH / DOWNLOAD AGAIN, 44

TABLE MISMATCH DOWNLOAD AGAIN, 289

TCB CORRUPTED \* message, 289

TCP Access Lists, 261

TCP/IP Access Problem, Windows, 189

TCP/IP Network, 143

Interface, 143

Routing, 143

TCP/IP NIC

Aliases, 158

assign values, 160

setting values, 159

setting values using a Network, 161

TCP/IP NIC configuration, 157

Temperature, 294

Terms, 303

Test Width, 131

Testing the printer, 278

Timeout, 124

TOF Action, 117, 119

Tractor pin engagement, 305

Trailer String, Print Model, 148

Trailer String, Print Path, 146

Transmitted data (TD) signal

RS-232 serial interface, 272

RS-422 serial interface, 273

Trickle Time, 124

Troubleshooting

10/100Base-T, 236

Novell 4.x and 5.x, 216

printing related, 240

RPRINTER/NPRINTER Setup, 239

Troubleshooting Tips

Unix, 202

Windows, 187

Truncate Alpha, 110

---

## U

UNDEF INTERRUPT \* message, 289  
UNDFNED OPCODE \* message, 289  
Unidirectional, 128  
Unix  
    Host configuration, 196  
    NIC configuration, 195  
    Routers, 195  
    Troubleshooting Tips, 202  
    using BOOTP, 163  
UP DRV. SHORT \* message, 289  
UPC Descenders, 105, 110  
Upper Case Select, 101  
URL, home page, 70  
Using BOOTP, Unix, 163

## V

Vertical formatting, 22

## W

WAITING FOR ETHERNET ADAPTER  
message, 289  
Warnings, 17  
Web JetAdmin, 317  
Windows  
    communicating, 177  
    environment description, 175  
    mandatory configuration, 176  
    NIC configuration, 176  
    NT 3.51configuration, 179  
    optional configuration, 176  
    routers, 177  
    TCP/IP access problem, 189  
Windows 3.1, host setup, 187  
Windows 95/98/ME Host Setup, 186  
Windows Configuration overview, 175  
Windows Network (NetBIOS TCP/IP), 144  
Windows NT 4.0 Host Setup, 180  
Windows Troubleshooting Tips, 187  
Word Length, 121  
Workgroup Names, changing, 177

## X

X-ON/X-OFF signal, RS-232 serial interface, 273





-----  
Printronix, Inc.  
14600 Myford Road  
Irvine, CA 92606-1005  
Phone: 714 / 368-2300  
Fax: 714 / 368-2600  
Customer Solutions Center: 714 / 368-2686

---

Printronix  
Nederland BV  
P.O. Box 163, Nieuweweg 283  
NL-6600 Ad Wijchen  
The Netherlands  
Phone: (31) 24 6489489  
Fax: (31) 24 6489499

---

Printronix Schweiz GmbH  
42 Changi South Street 1  
Changi South Industrial Estate  
Singapore 486763  
Phone: (65) 6542-0110  
Fax: (65) 6543-0220

Visit our web site at:  
[www.p5000lj.com](http://www.p5000lj.com)



173952-001D



## Free Manuals Download Website

<http://myh66.com>

<http://usermanuals.us>

<http://www.somanuals.com>

<http://www.4manuals.cc>

<http://www.manual-lib.com>

<http://www.404manual.com>

<http://www.luxmanual.com>

<http://aubethermostatmanual.com>

Golf course search by state

<http://golfingnear.com>

Email search by domain

<http://emailbydomain.com>

Auto manuals search

<http://auto.somanuals.com>

TV manuals search

<http://tv.somanuals.com>