

PRO-FORM® 650 CardioCrossTrainer

Model No. PFEL2605.0

Serial No. _____

Serial
Number
Decal

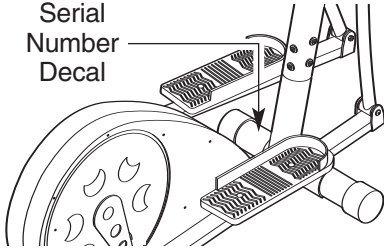

USER'S MANUAL

QUESTIONS?

As a manufacturer, we are committed to providing complete customer satisfaction. If you have questions, or if parts are damaged or missing, PLEASE CONTACT OUR CUSTOMER SERVICE DEPARTMENT DIRECTLY.

CALL TOLL-FREE:

1-888-533-1333

Mon.-Fri., 6 a.m.-6 p.m. MST

ON THE WEB:

www.proformservice.com

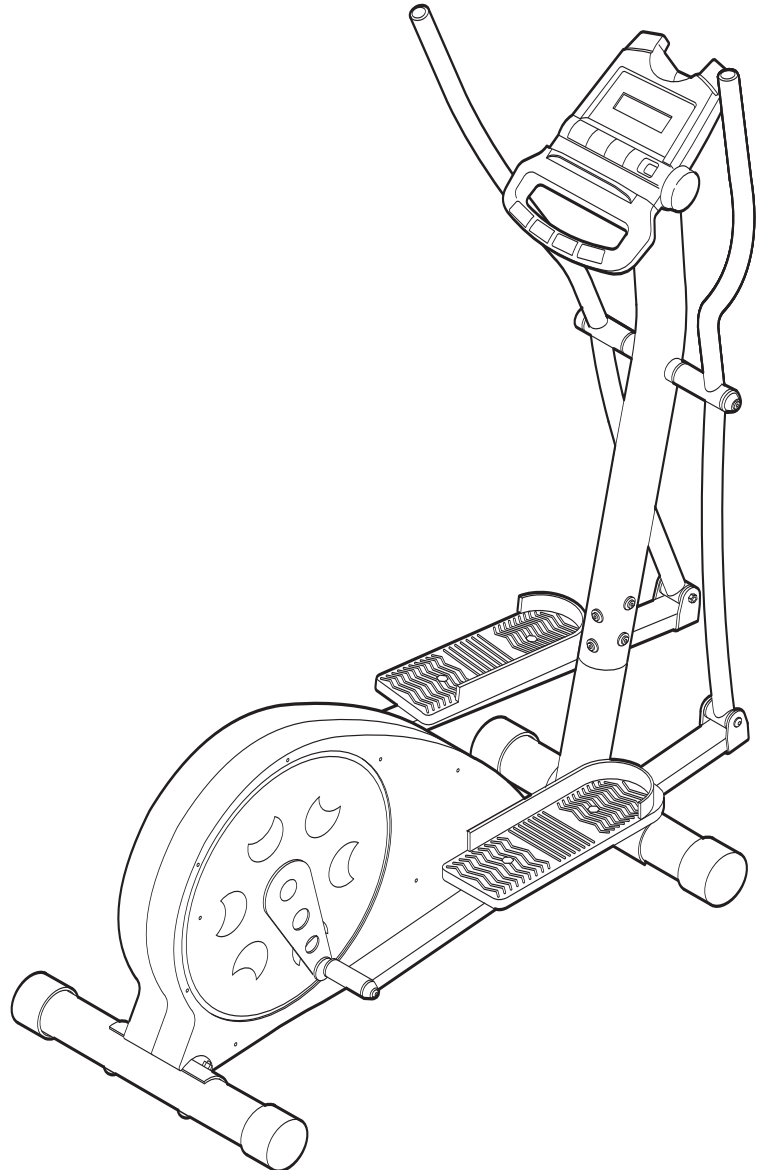

CAUTION

Read all precautions and instructions in this manual before using this equipment. Keep this manual for future reference.



Visit our website at

www.proform.com

*new products, prizes,
fitness tips, and much more!*

TABLE OF CONTENTS

IMPORTANT PRECAUTIONS	2
BEFORE YOU BEGIN	3
ASSEMBLY	4
HOW TO USE THE ELLIPTICAL EXERCISER	8
MAINTENANCE AND TROUBLESHOOTING	11
CONDITIONING GUIDELINES	12
PART LIST	14
EXPLODED DRAWING	15
HOW TO ORDER REPLACEMENT PARTS	Back Cover
LIMITED WARRANTY	Back Cover

IMPORTANT PRECAUTIONS

⚠ WARNING: To reduce the risk of serious injury, read the following important precautions before using the elliptical exerciser.

1. Read all instructions in this manual and all warnings on the elliptical exerciser before using the elliptical exerciser.
2. It is the responsibility of the owner to ensure that all users of the elliptical exerciser are adequately informed of all precautions.
3. The elliptical exerciser is intended for home use only. Do not use the elliptical exerciser in a commercial, rental, or institutional setting.
4. Keep the elliptical exerciser indoors, away from moisture and dust. Place the elliptical exerciser on a level surface, with a mat beneath it to protect the floor or carpet. Make sure that there is enough clearance around the elliptical exerciser to mount, dismount, and use it.
5. Inspect and properly tighten all parts regularly. Replace any worn parts immediately.
6. Keep children under 12 and pets away from the elliptical exerciser at all times.
7. The elliptical exerciser should not be used by persons weighing more than 250 pounds.
8. Wear appropriate exercise clothes when using the elliptical exerciser. Always wear athletic shoes for foot protection while exercising.
9. When mounting and dismounting the elliptical exerciser, always hold the handlebars and step onto and off the pedal that is in the lowest position.
10. The pulse sensor is not a medical device. Various factors may affect the accuracy of heart rate readings. The pulse sensor is intended only as an exercise aid in determining heart rate trends in general.
11. Keep your back straight when using the elliptical exerciser; do not arch your back.
12. If you feel pain or dizziness while exercising, stop immediately and cool down.
13. When you stop exercising, allow the pedals to slowly come to a stop.

⚠ WARNING: Before beginning this or any exercise program, consult your physician. This is especially important for persons over the age of 35 or persons with pre-existing health problems. Read all instructions before using. ICON assumes no responsibility for personal injury or property damage sustained by or through the use of this product.

BEFORE YOU BEGIN

Thank you for selecting the new PROFORM® Cardio Crosstrainer 650 low-impact elliptical exerciser. The Cardio Crosstrainer 650 is an incredibly smooth exerciser that moves your feet in a natural elliptical path, minimizing the impact on your knees and ankles. Welcome to a whole new world of natural, elliptical-motion exercise.

For your benefit, read this manual carefully before you use the elliptical exerciser. If you have questions after reading this manual, see the front cover of this manual. To help us assist you, please note the

product model number and serial number before contacting us. The model number is PFEL2605.0. The serial number can be found on a decal attached to the elliptical exerciser (see the front cover of this manual).

To avoid a registration fee for any service needed under warranty, you must register the elliptical exerciser at www.proformservice.com/registration.

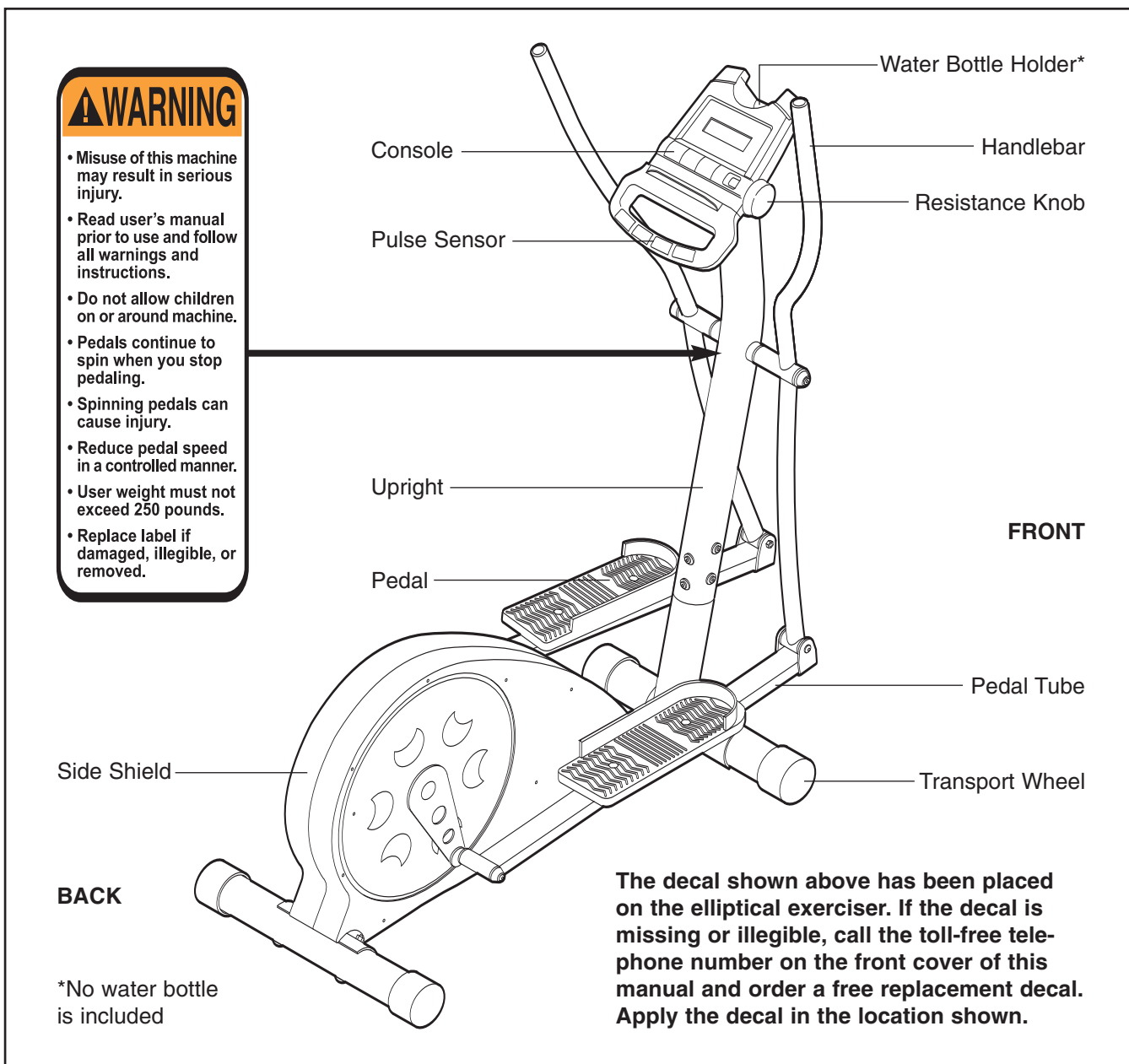

Before reading further, please familiarize yourself with the parts that are labeled in the drawing below.



ASSEMBLY

To hire an authorized service technician to assemble the elliptical exerciser, call toll-free 1-800-445-2480.

Assembly requires two persons. Place all parts of the elliptical exerciser in a cleared area and remove the packing materials. Do not dispose of the packing materials until assembly is completed.

Assembly requires a phillips screwdriver , two adjustable wrenches , and a rubber mallet .

See the drawings below to identify the small parts needed for assembly. The number in parentheses below each drawing is the key number of the part, from the PART LIST on page 14. The number following the key number is the quantity needed for assembly. **Note: Some small parts may have been preassembled. If a part is not found in the parts bag, check to see if it has been preassembled.**

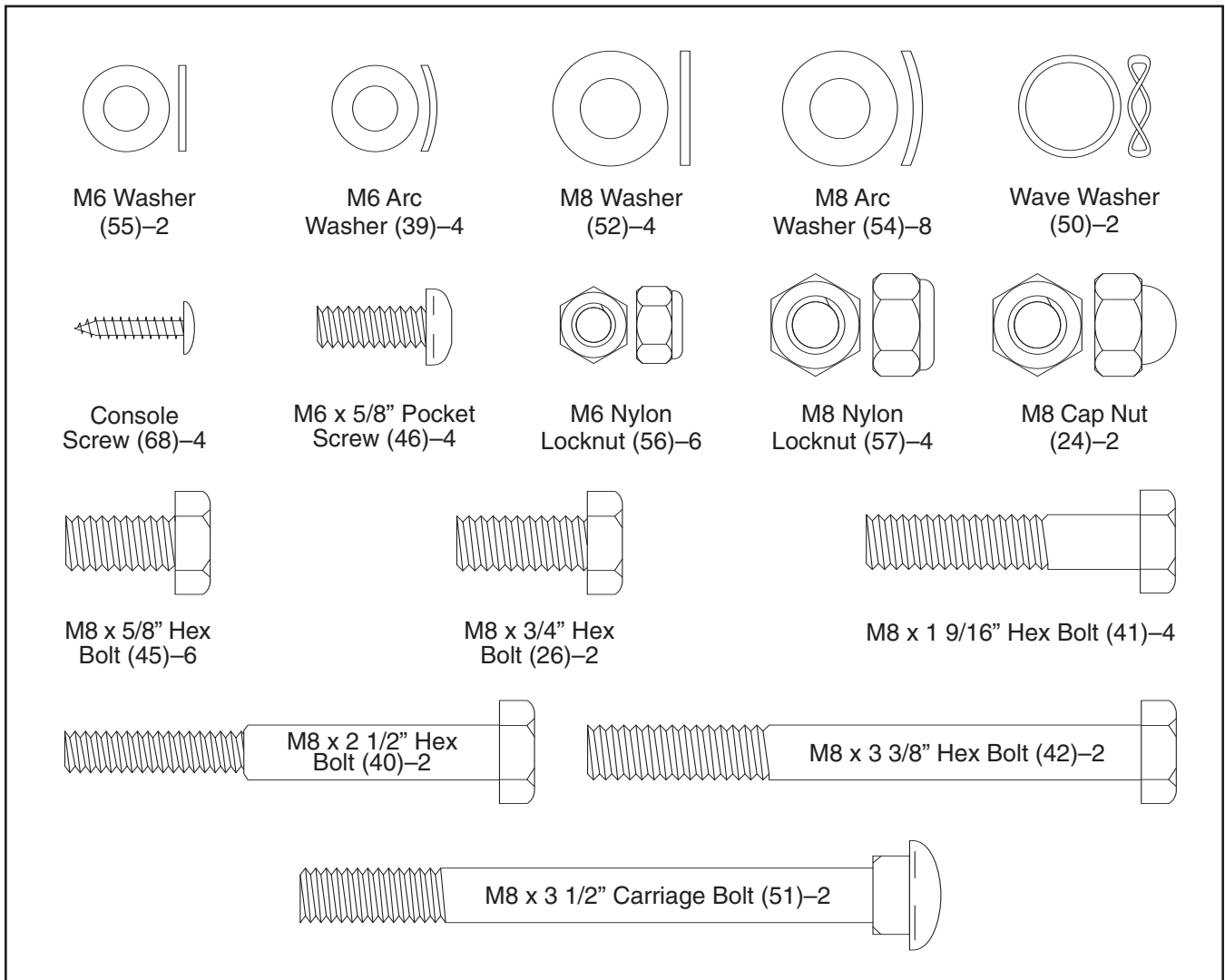

1. Identify the Front Stabilizer (2), which has Transport Wheels (29) attached to it. Attach the Front Stabilizer to the Frame (1) with two M8 x 3 1/2" Carriage Bolts (51), two M8 Arc Washers (54), and two M8 Cap Nuts (24).

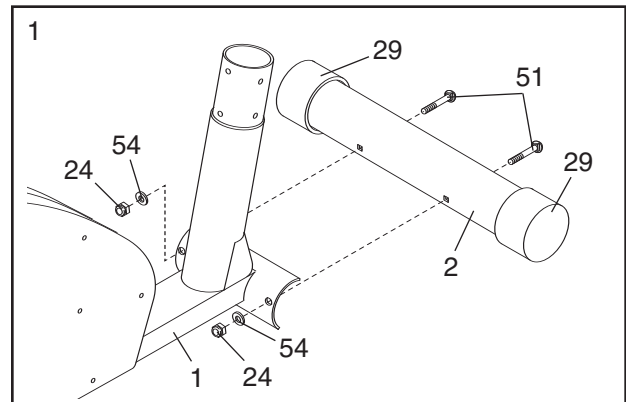

2. Tip the Frame (1) up onto its front end as shown. While another person holds the Frame, attach the Rear Stabilizer (20) to the Frame with two M8 x 3 3/8" Hex Bolts (42).

With the help of another person, tip the Frame (1) back down so that it is resting on the Rear and Front Stabilizers (2, 20).

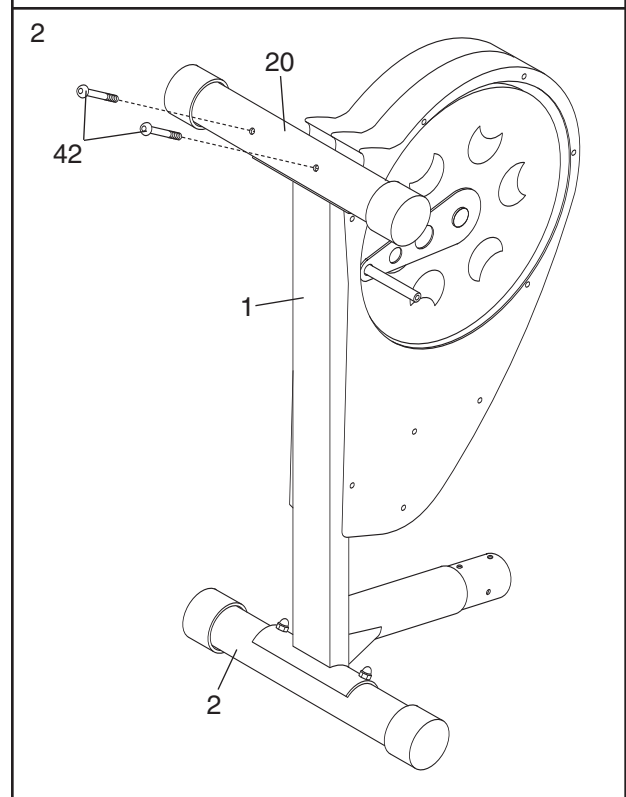

3. The Console (22) requires three "AA" batteries; alkaline batteries are recommended. Insert three batteries into the Console; **make sure that the batteries are oriented as shown by the markings inside of the Console.**

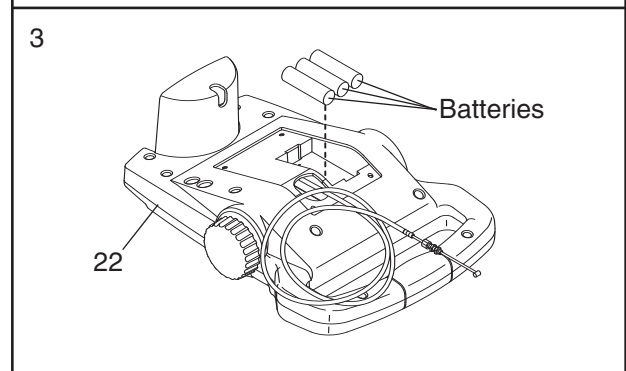

- While another person holds the Console (22) near the top of the Upright (3), feed the console cable and the console wire down through the Upright. Next, attach the ground wire to the Upright with a Console Screw (68).

Attach the Console (22) to the Upright (3) with three Console Screws (68). **Be careful to avoid pinching the cables or the wires.**

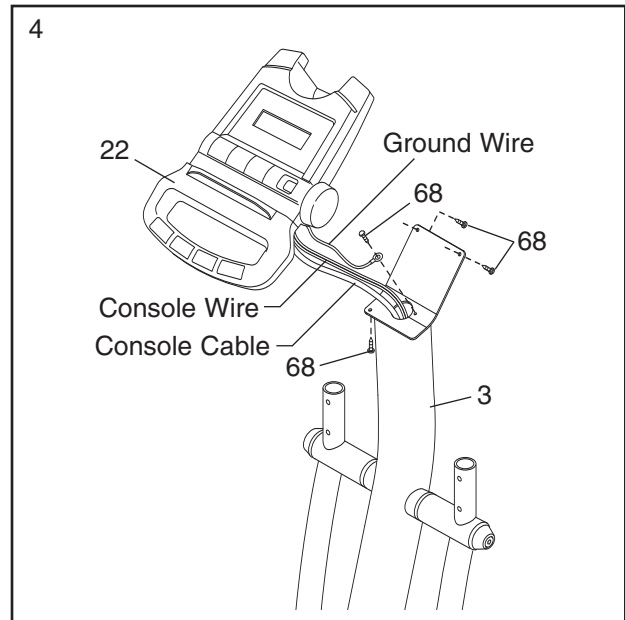

- While another person holds the Upright (3) near the Frame (1), connect the console wire to the Reed Switch Wire (67). Next, connect the console cable to the Resistance Cable (70) in the following way:

- See drawing A. Pull up on the metal bracket on the Resistance Cable (70), and insert the tip of the console cable (a) into the wire clip inside of the metal bracket.
- See drawing B. While another person pulls up on the Upright (3), slide the console cable (a) into the metal bracket on the Resistance Cable (70) as shown.
- See drawing C. Using pliers, squeeze together the prongs on the upper end of the metal bracket.

Slide the Upright (3) onto the Frame (1). **Be careful to avoid pinching the cables or the wires.** Align the holes in the Upright with the holes in the Frame. Attach the Upright with six M8 x 5/8" Hex Bolts (45) and six M8 Arc Washers (54).

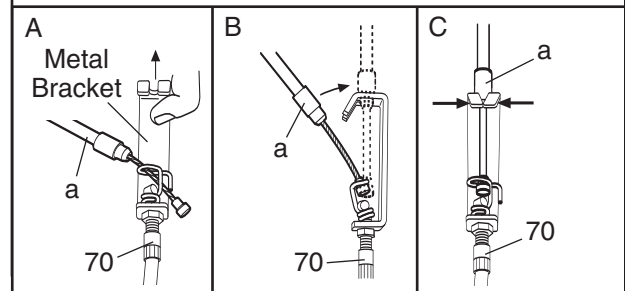
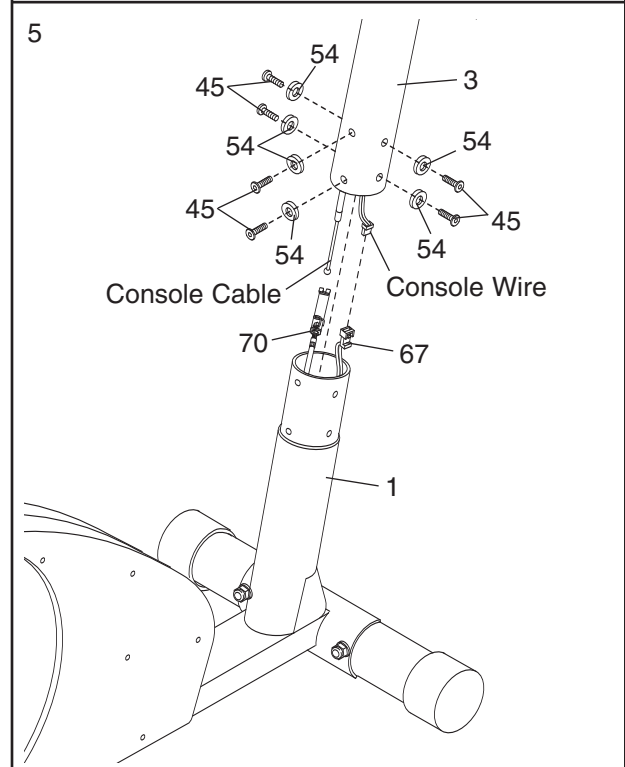

- Identify the Right Pedal (63), which has an "R" molded into its bottom surface, and the Right Pedal Tube (64), which is marked with a sticker.

Attach the Right Pedal (63) to the Right Pedal Tube (64) with two M8 x 1 9/16" Hex Bolts (41), two M8 Washers (52), and two M8 Nylon Locknuts (57).

Attach the Left Pedal (not shown) to the Left Pedal Tube (not shown) in the same way.

- Apply a thin film of the included grease to the parts shown at the right.

Slide a Wave Washer (50) onto the axle on the Right Crank Arm (15). Next, slide the Right Pedal Tube (64) onto the axle. Attach the Right Pedal Tube with an M8 x 3/4" Hex Bolt (26) and a Nylon Bushing (32).

Attach the Right Pedal Tube (64) to the right Handlebar Leg (5) with an M8 x 2 1/2" Hex Bolt (40), an M6 Washer (55), and an M6 Nylon Locknut (56).

Repeat this step to attach the Left Pedal Tube (not shown) to the left side of the elliptical exerciser.

- Insert a Plastic Sleeve (16) into the top of the right Handlebar Leg (5). Then, insert a Handlebar (6) into the right Handlebar Leg. Align the holes in the Handlebar with the holes in the Handlebar Leg. Attach the Handlebar with two M6 x 5/8" Pocket Screws (46), two M6 Arc Washers (39), and two M6 Nylon Locknuts (56).

Attach the other Handlebar (6) to the left Handlebar Leg (5) in the same way.

- Make sure that all parts of the elliptical exerciser are properly tightened.** Place a mat under the elliptical exerciser to protect the floor or carpet from damage.

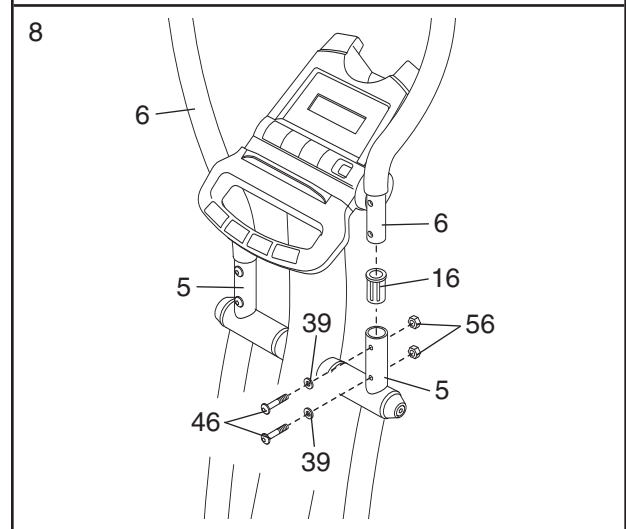
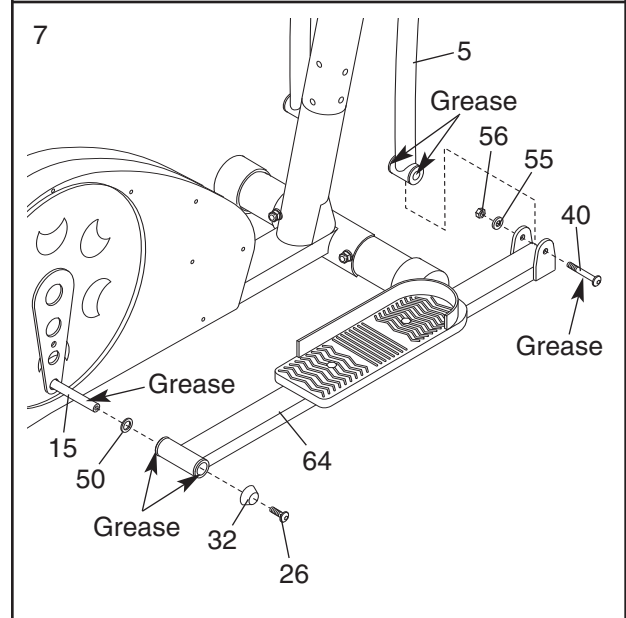
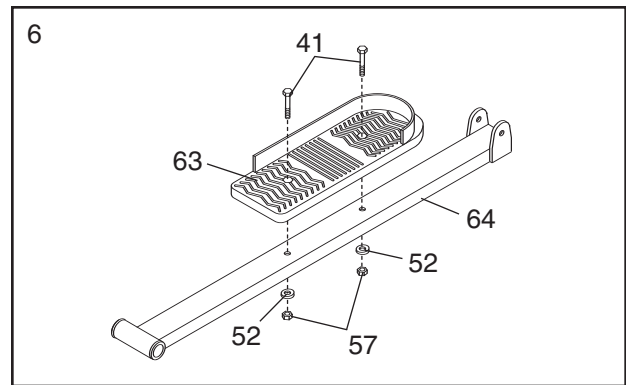

HOW TO USE THE ELLIPTICAL EXERCISER

HOW TO EXERCISE ON THE ELLIPTICAL EXERCISER

To mount the elliptical exerciser, firmly hold the handlebars and carefully step onto the pedal that is in the lowest position. Next, step onto the

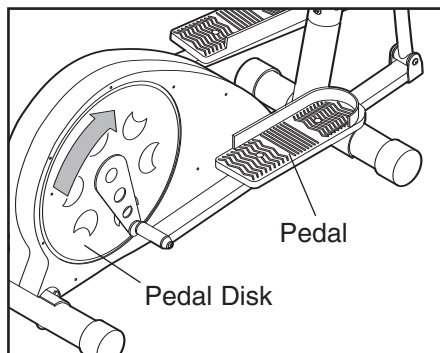

other pedal. Push the pedals until they begin to move with a continuous motion. **Note: The pedal disks can turn in either direction. It is recommended that you turn the pedal disks in the direction shown above; however, for variety, you can turn the pedal disks in the opposite direction.**

To dismount the elliptical exerciser, allow the pedals to come to a complete stop. **CAUTION: The elliptical exerciser does not have a freewheel; the pedals will continue to move until the flywheel stops.** When the pedals are stationary, step off the highest pedal first. Then, step off the lowest pedal.

To add upper-body exercise to your workouts on the elliptical exerciser, push and pull the handlebars to work your arms, shoulders, and back.

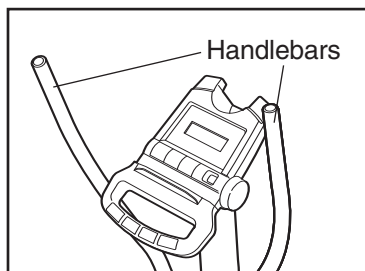

HOW TO ADJUST THE RESISTANCE

To increase the resistance of the pedals, turn the resistance knob clockwise; to decrease the resistance, turn the knob counterclockwise.

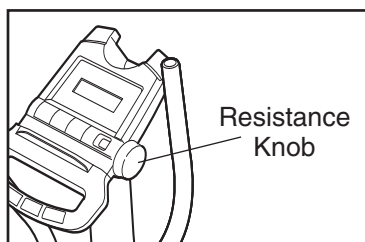

Important: Stop turning the knob when turning becomes difficult, or damage may result.

FEATURES OF THE CONSOLE

The easy-to-use console is designed to help you get the most from your workouts. As you exercise, the console will display the following modes:

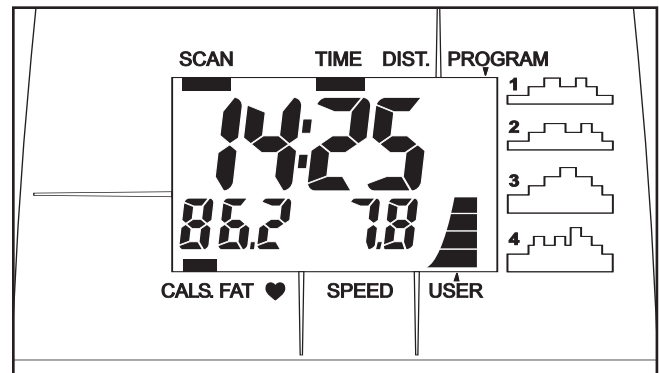

Time—This mode displays the elapsed time (or the time remaining in a pace program). Note: If you stop pedaling, the time will begin to flash.

Distance—This mode displays the distance that you have pedaled.

Calories—This mode displays the approximate number of calories you have burned.

Fat calories—This mode displays the approximate number of fat calories you have burned (see FAT BURNING on page 12).

Pulse—This mode displays your heart rate when you use the pulse sensor.

Speed—This mode displays your pedaling speed.

Scan—When this mode is selected, the upper section of the display will show both the time mode and the distance mode, and the lower left section of the display will show the calories mode and the fat calories mode.

The console also offers four pace programs. Each program automatically prompts you to increase or decrease your pace as it guides you through an effective workout.

HOW TO USE THE MANUAL MODE

Note: If there is a sheet of clear plastic on the console, peel off the plastic.

1 Turn on the console.

To turn on the console, press the On/Reset button or begin pedaling.

2 Select the manual mode.

Each time the console is turned on, the manual mode will be selected. If a pace program has been selected, select the manual

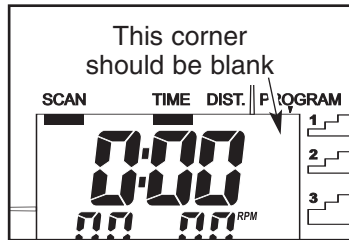

mode by pressing the Program button repeatedly until the upper right corner of the display is blank.

3 Begin pedaling and adjust the resistance of the pedals.

As you exercise, adjust the resistance of the pedals as desired by turning the resistance knob.

4 Follow your progress with the display.

When the console is turned on, the scan mode will be selected, as shown by the mode bar below the word SCAN. As you exercise, the upper section of the display will alternately show the elapsed time and the distance that you have pedaled; the lower left section of the display will alternately show the number of calories you have burned and the number of fat calories you have burned; and the lower right section will show your pedaling speed.

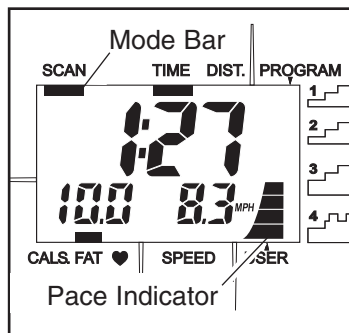

In addition, the pace indicator on the right side of the display will provide a visual representation of your pedaling pace. As you increase or decrease your pace, the indicator will increase or decrease in height.

To cancel the scan mode, press the Mode button. The mode bar below the word SCAN will disappear. The upper section of the display will then show only the elapsed time, and the lower left section of the display will show only the number of calories you have burned. Press the Mode button again. The upper section of the display will then show only the distance pedaled, and the lower left section of the display will show only the number of fat calories you have burned. To select the scan mode again, press the Mode button repeatedly until a mode bar appears below the word SCAN.

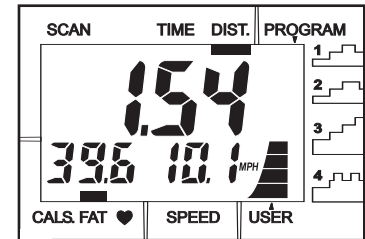

To reset the display, press the On/Reset button.

Note: The console can show speed and distance in either miles or kilometers. To change the unit of measurement, hold down the On/Reset button for about six seconds. When the batteries are replaced, it may be necessary to reselect the desired unit of measurement.

5 Measure your heart rate if desired.

Note: If there are sheets of clear plastic on the metal contacts of the pulse sensor, peel off the plastic.

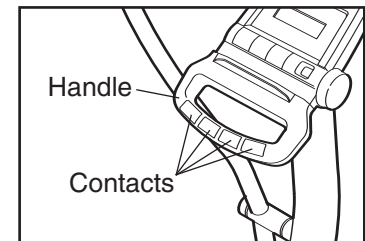

To use the pulse sensor, hold the handle on the console, with your right palm covering the two right contacts and your left palm covering the two left contacts. Avoid moving your hands. When your pulse is detected, the heart-shaped indicator in the display will flash each time your heart beats and two dashes (--) will appear. After a moment, your heart rate will be shown. For the most accurate heart rate reading, continue to hold the handgrips for about 15 seconds.

6 When you are finished exercising, the console will automatically turn off after a few minutes.

If the pedals are not moved and the console buttons are not pressed for a few minutes, **the console will automatically turn off to conserve the batteries.**

HOW TO USE A PACE PROGRAM

1 Turn on the console.

See step 1 on page 9.

2 Select one of the four pace programs.

Each time the console is turned on, the manual mode will be selected.

To select a pace program, press the Program button repeatedly until the number 1, 2, 3, or 4 appears in the upper right corner of the display.

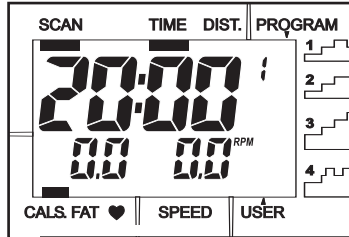

The four profiles on the right side of the console show how the target pace will change during the programs. For example, profile number 1 shows that during program 1, the target pace will increase near the beginning of the program, and then decrease near the end.

3 Start the program.

To start the program, begin pedaling. Each program consists of either 20 or 30 one-minute periods. One target pace is programmed for each period. (The same target pace setting may be programmed for consecutive periods.)

The target pace settings for the program will be shown by the target pace indicator in the display. (The pace indicator will show your actual pedaling pace.) As the

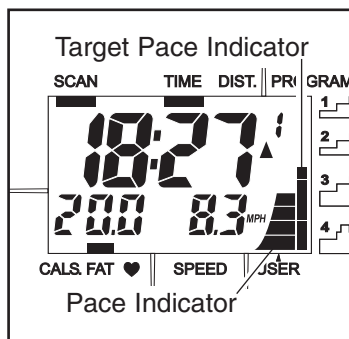

target pace indicator changes in height during the program, adjust your pedaling pace so that both indicators are the same height. If your pedaling pace is slower than the current target pace setting, an arrow will appear next to the pace indicators to prompt you to increase your pace; if your pace is faster than the target pace, an arrow will prompt you to decrease your pace.

Important: The target pace settings for the program are intended only to provide a goal. Your actual pace may be slower than the target pace settings, especially during the first few months of your exercise program. Make sure to exercise at a pace that is comfortable for you.

During the program, adjust the resistance of the pedals as desired by turning the resistance knob.

The display will show the time remaining in the program. If you continue exercising after the program is completed, the display will continue to show your exercise feedback.

4 Follow your progress with the display.

See step 4 on page 9.

5 Measure your heart rate if desired.

See step 5 on page 9.

6 When you are finished exercising, the console will automatically turn off after a few minutes.

See step 6 on page 9.

MAINTENANCE AND TROUBLESHOOTING

Inspect and properly tighten all parts of the elliptical exerciser regularly. Replace any worn parts immediately.

The elliptical exerciser can be wiped clean with a soft cloth and mild detergent. **Do not use abrasives or solvents.** To prevent damage to the console, keep liquids away from the console and keep the console out of direct sunlight.

When storing the elliptical exerciser, remove the batteries from the console. Keep the elliptical exerciser in a clean, dry location, away from moisture and dust.

CONSOLE TROUBLESHOOTING

If the console does not function properly, the batteries should be replaced. To replace the batteries, see assembly steps 3 and 4 on pages 5 and 6.

HANDGRIP PULSE SENSOR TROUBLESHOOTING

If the handgrip pulse sensor does not function properly, see step 5 on page 9.

CONDITIONING GUIDELINES

WARNING:



Before beginning this or any exercise program, consult your physician. This is especially important for individuals over the age of 35 or individuals with pre-existing health problems.

The pulse sensor is not a medical device. Various factors may affect the accuracy of heart rate readings. The pulse sensor is intended only as an exercise aid in determining heart rate trends in general.

The following guidelines will help you to plan your exercise program. Remember that proper nutrition and adequate rest are essential for successful results.

EXERCISE INTENSITY

Whether your goal is to burn fat or to strengthen your cardiovascular system, the key to achieving the desired results is to exercise with the proper intensity. The proper intensity level can be found by using your heart rate as a guide. The chart below shows recommended heart rates for fat burning, maximum fat burning, and cardiovascular (aerobic) exercise.

165	155	145	140	130	125	115	
145	138	130	125	118	110	103	
125	120	115	110	105	95	90	
20	30	40	50	60	70	80	

To find the proper heart rate for you, first find your age near the bottom of the chart (ages are rounded off to the nearest ten years). Next, find the three numbers above your age; the three numbers are your “training zone.” The lowest number is the recommended heart rate for fat burning; the middle number is the recommended heart rate for maximum fat burning; and the highest number is the heart rate for aerobic exercise.

Fat Burning

To burn fat effectively, you must exercise at a relatively low intensity level for a sustained period of time. During the first few minutes of exercise, your body uses easily accessible *carbohydrate* calories for energy. Only after the first few minutes of exercise does your body begin to use stored *fat* calories for energy. If your goal is to burn fat, adjust the intensity of your exercise until your heart rate is near the lowest number or the middle number in your training zone as you exercise.

Aerobic Exercise

If your goal is to strengthen your cardiovascular system, your exercise must be “aerobic.” Aerobic exercise is activity that requires large amounts of oxygen for prolonged periods of time. This increases the demand on the heart to pump blood to the muscles, and on the lungs to oxygenate the blood. For aerobic exercise, adjust the intensity of your exercise until your heart rate is near the highest number in your training zone.

WORKOUT GUIDELINES

Each workout should include the following three parts:

A warm-up, consisting of 5 to 10 minutes of stretching and light exercise. A proper warm-up increases your body temperature, heart rate, and circulation in preparation for exercise.

Training zone exercise, consisting of 20 to 30 minutes of exercising with your heart rate in your training zone. (During the first few weeks of your exercise program, do not keep your heart rate in your training zone for longer than 20 minutes.)

A cool-down, with 5 to 10 minutes of stretching. This will increase the flexibility of your muscles and will help to prevent post-exercise problems.

EXERCISE FREQUENCY

To maintain or improve your condition, plan three workouts each week, with at least one day of rest between workouts. After a few months of regular exercise, you may complete up to five workouts each week, if desired. The key to success is make exercise a regular and enjoyable part of your everyday life.

SUGGESTED STRETCHES

The correct form for several basic stretches is shown at the right. Move slowly as you stretch—never bounce.

1. Toe Touch Stretch

Stand with your knees bent slightly and slowly bend forward from your hips. Allow your back and shoulders to relax as you reach down toward your toes as far as possible. Hold for 15 counts, then relax. Repeat 3 times. Stretches: Hamstrings, back of knees, and back.

2. Hamstring Stretch

Sit with one leg extended. Bring the sole of the opposite foot toward you and rest it against the inner thigh of your extended leg. Reach toward your toes as far as possible. Hold for 15 counts, then relax. Repeat 3 times for each leg. Stretches: Hamstrings, lower back, and groin.

3. Calf/Achilles Stretch

With one leg in front of the other, reach forward and place your hands against a wall. Keep your back leg straight and your back foot flat on the floor. Bend your front leg, lean forward and move your hips toward the wall. Hold for 15 counts, then relax. Repeat 3 times for each leg. To cause further stretching of the achilles tendons, bend your back leg as well. Stretches: Calves, achilles tendons, and ankles.

4. Quadriceps Stretch

With one hand against a wall for balance, reach back and grasp one foot with your other hand. Bring your heel as close to your buttocks as possible. Hold for 15 counts, then relax. Repeat 3 times for each leg. Stretches: Quadriceps and hip muscles.

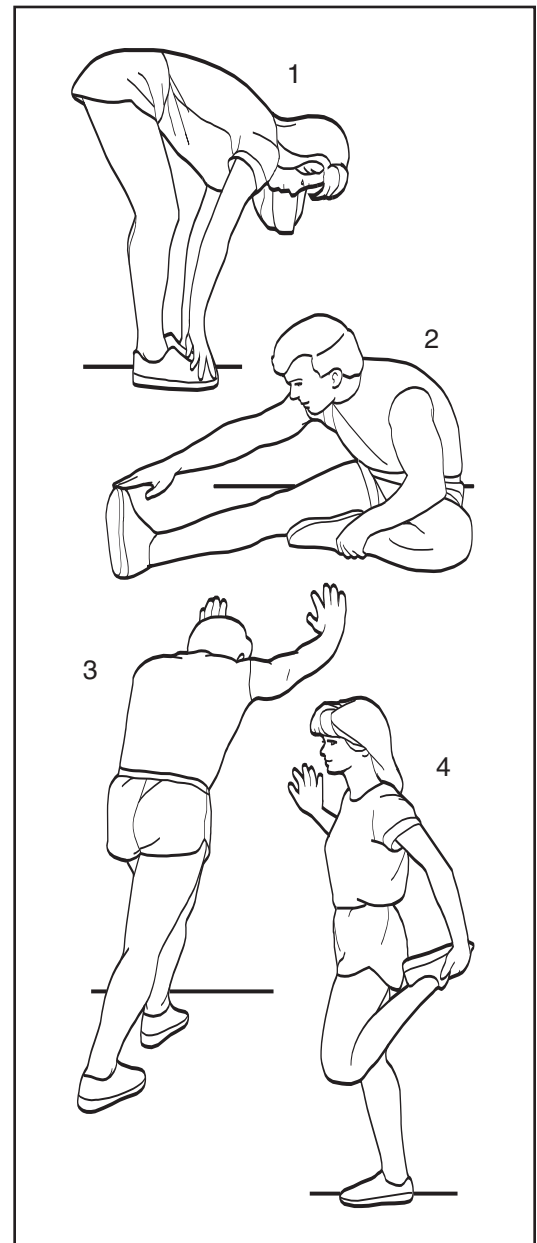

PART LIST—Model No. PFEL2605.0

R0905A

Key No.	Qty.	Description	Key No.	Qty.	Description
1	1	Frame	38	2	Adjustment Bracket
2	1	Front Stabilizer	39	4	M6 Arc Washer
3	1	Upright	40	2	M8 x 2 1/2" Hex Bolt
4	1	Left Pedal Tube	41	4	M8 x 1 9/16" Hex Bolt
5	2	Handlebar Leg	42	2	M8 x 3 3/8" Hex Bolt
6	2	Handlebar	43	1	M8 x 2 3/8" Hex Bolt
7	1	Flywheel	44	1	M8 x 2 3/8" Tap Hex Bolt
8	1	Left Pedal	45	6	M8 x 5/8" Hex Bolt
9	1	Flywheel Axle	46	4	M6 x 5/8" Pocket Screw
10	1	"C" Magnet	47	12	M5 x 5/8" Pocket Screw
11	2	Upright Spacer	48	5	M4 x 1 9/16" Pocket Screw
12	2	Crank Cover	49	2	M4 x 5/8" Pocket Screw
13	2	Handlebar Endcap	50	4	Wave Washer
14	1	Driving Wheel Assembly	51	2	M8 x 3 1/2" Carriage Bolt
15	1	Right Crank Arm	52	5	M8 Washer
16	2	Plastic Sleeve	53	5	M10 Washer
17	8	Handlebar Bushing	54	8	M8 Arc Washer
18	1	Spring	55	2	M6 Washer
19	2	Foam Handle Grip	56	7	M6 Nylon Locknut
20	1	Rear Stabilizer	57	6	M8 Nylon Locknut
21	1	Left Side Shield	58	2	M10 Nylon Locknut
22	1	Console	59	2	M8 Hex Nut
23	4	Leg Bushing	60	1	Magnet
24	2	M8 Cap Nut	61	2	M3 x 1/2" Pocket Screw
25	1	Left Disc Cover	62	2	M10 Spacer
26	4	M8 x 3/4" Hex Bolt	63	1	Right Pedal
27	2	Bearing Cover	64	1	Right Pedal Tube
28	2	Rear Stabilizer Endcap	65	1	Right Side Shield
29	2	Transport Wheel	66	1	Right Disc Cover
30	1	Drive Belt	67	1	Reed Switch/Wire
31	2	Plastic Washer	68	5	Console Screw
32	4	Nylon Bushing	69	1	Reed Switch Bracket
33	2	Flywheel Bearing	70	1	Resistance Cable
34	2	Crank Bearing	#	1	Allen Wrench Set
35	2	Pedal Tube Endcap	#	1	Grease
36	1	"C" Clip	#	1	User's Manual
37	2	Eyebolt			

Note: "#" indicates a non-illustrated part. Specifications are subject to change without notice. See the back cover of this manual for information about ordering replacement parts.

EXPLODED DRAWING—Model No. PFEL2605.0

R0905A

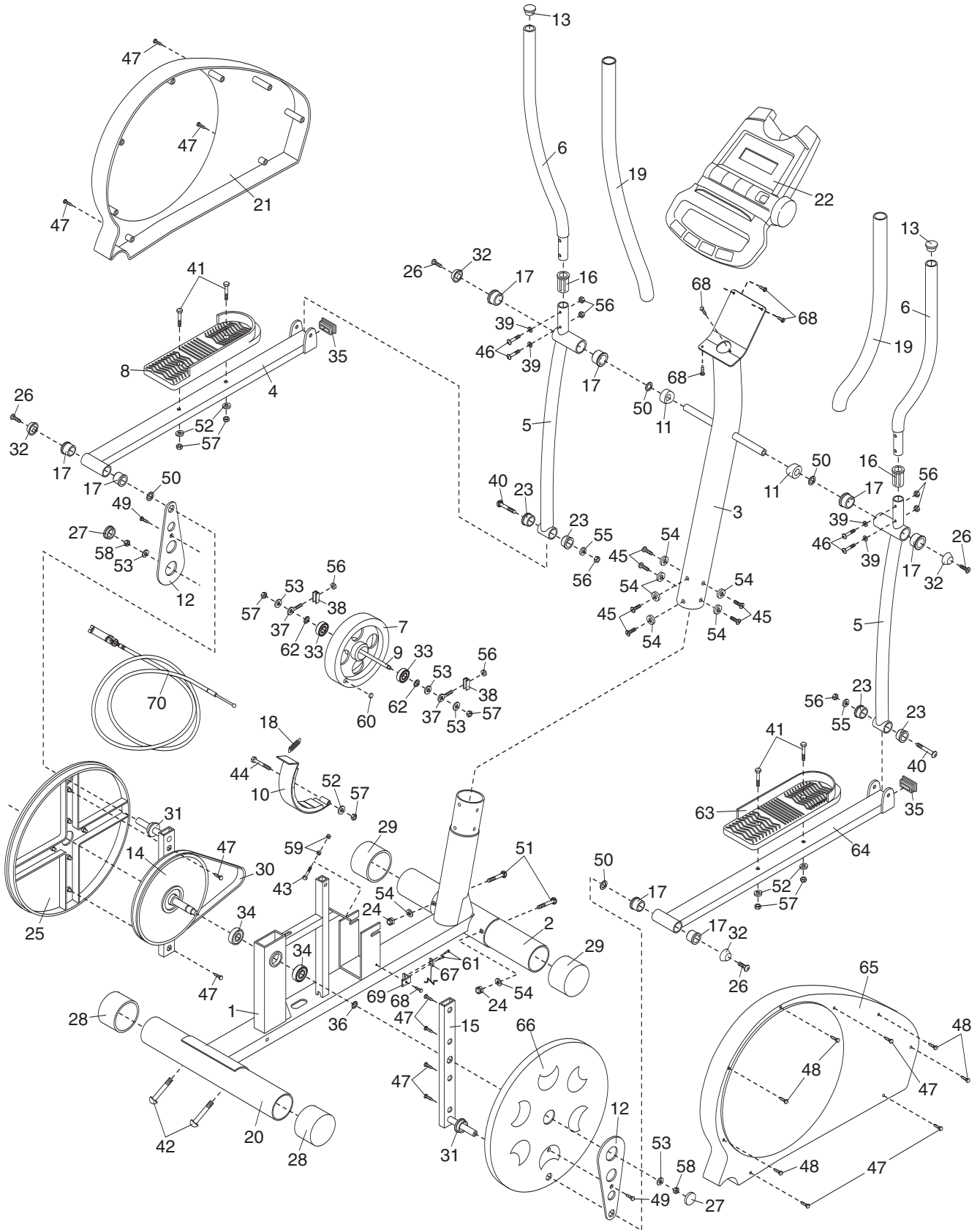

HOW TO ORDER REPLACEMENT PARTS

To order replacement parts, see the front cover of this manual. To help us assist you, please be prepared to give the following information when calling:

- the MODEL NUMBER of the product (PFEL2605.0)
- the NAME of the product (PROFORM Cardio Crosstrainer 650 elliptical exerciser)
- the SERIAL NUMBER of the product (see the front cover of this manual)
- the KEY NUMBER and DESCRIPTION of the part(s) (see page 14)

PROFORM is a registered trademark of ICON IP, Inc.

LIMITED WARRANTY

ICON Health & Fitness, Inc. (ICON), warrants this product to be free from defects in workmanship and material, under normal use and service conditions, for a period of ninety (90) days from the date of purchase. This warranty extends only to the original purchaser. ICON's obligation under this warranty is limited to replacing or repairing, at ICON's option, the product through one of its authorized service centers. All repairs for which warranty claims are made must be pre-authorized by ICON. If the product is shipped to a service center, freight charges to and from the service center will be the customer's responsibility. For in-home service, the customer will be responsible for a minimal trip charge. This warranty does not extend to any product or damage to a product caused by or attributable to freight damage, abuse, misuse, improper or abnormal usage or repairs not provided by an ICON authorized service center; products used for commercial or rental purposes; or products used as store display models. No other warranty beyond that specifically set forth above is authorized by ICON.

ICON is not responsible or liable for indirect, special or consequential damages arising out of or in connection with the use or performance of the product or damages with respect to any economic loss, loss of property, loss of revenues or profits, loss of enjoyment or use, costs of removal or installation or other consequential damages of whatsoever nature. Some states do not allow the exclusion or limitation of incidental or consequential damages. Accordingly, the above limitation may not apply to you.

The warranty extended hereunder is in lieu of any and all other warranties and any implied warranties of merchantability or fitness for a particular purpose is limited in its scope and duration to the terms set forth herein. Some states do not allow limitations on how long an implied warranty lasts. Accordingly, the above limitation may not apply to you.

This warranty gives you specific legal rights. You may also have other rights which vary from state to state.

ICON HEALTH & FITNESS, INC., 1500 S. 1000 W., LOGAN, UT 84321-9813

Free Manuals Download Website

<http://myh66.com>

<http://usermanuals.us>

<http://www.somanuals.com>

<http://www.4manuals.cc>

<http://www.manual-lib.com>

<http://www.404manual.com>

<http://www.luxmanual.com>

<http://aubethermostatmanual.com>

Golf course search by state

<http://golfingnear.com>

Email search by domain

<http://emailbydomain.com>

Auto manuals search

<http://auto.somanuals.com>

TV manuals search

<http://tv.somanuals.com>