

PRO-FORM[®]

XP 160

Model No. PFANBE2525.0

Serial No. _____

Write the serial number in the space above for reference.

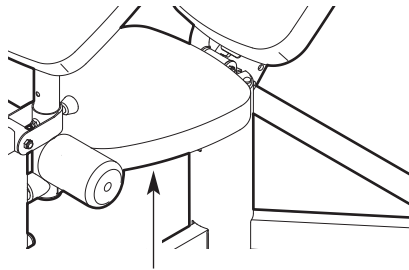

Serial Number Decal (under seat)

USER'S MANUAL

QUESTIONS?

As a manufacturer, we are committed to providing complete customer satisfaction.

If you have questions, or if there are missing or damaged parts, please call the telephone number on the warranty card accompanying this manual or contact the establishment where you purchased this product.

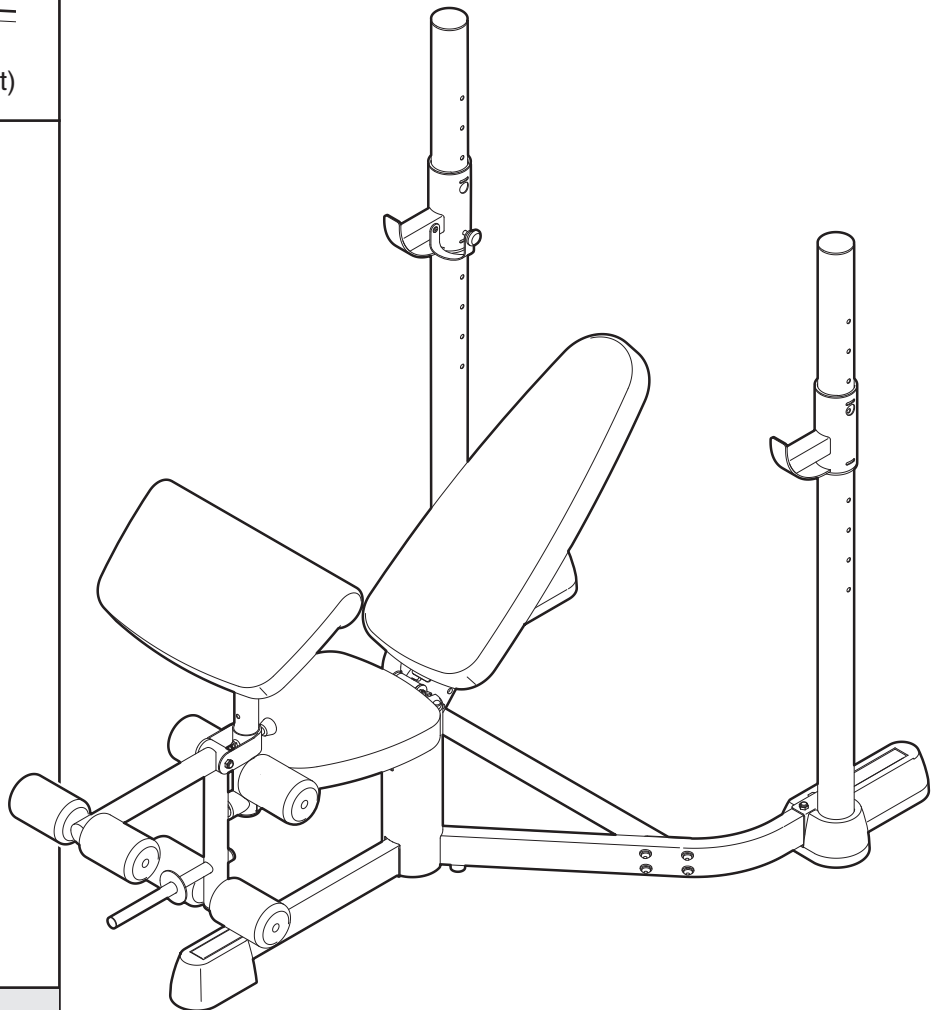

⚠ CAUTION

Read all precautions and instructions in this manual before using this equipment. Save this manual for future reference.

TABLE OF CONTENTS

WARNING DECAL PLACEMENT	2
IMPORTANT PRECAUTIONS	3
BEFORE YOU BEGIN	4
ASSEMBLY	5
ADJUSTMENTS	9
EXERCISE GUIDELINES	10
ORDERING REPLACEMENT PARTS	Back Cover

Note: A PART IDENTIFICATION CHART and a PART LIST/EXPLODED DRAWING are attached in the center of this manual. Remove the PART IDENTIFICATION CHART and PART LIST/EXPLODED DRAWING before beginning assembly.

WARNING DECAL PLACEMENT

The decal shown here has been placed on the weight bench. If the decal is missing, call the telephone number on the warranty card accompanying this manual and order a free replacement decal. Apply the decal in the location shown.

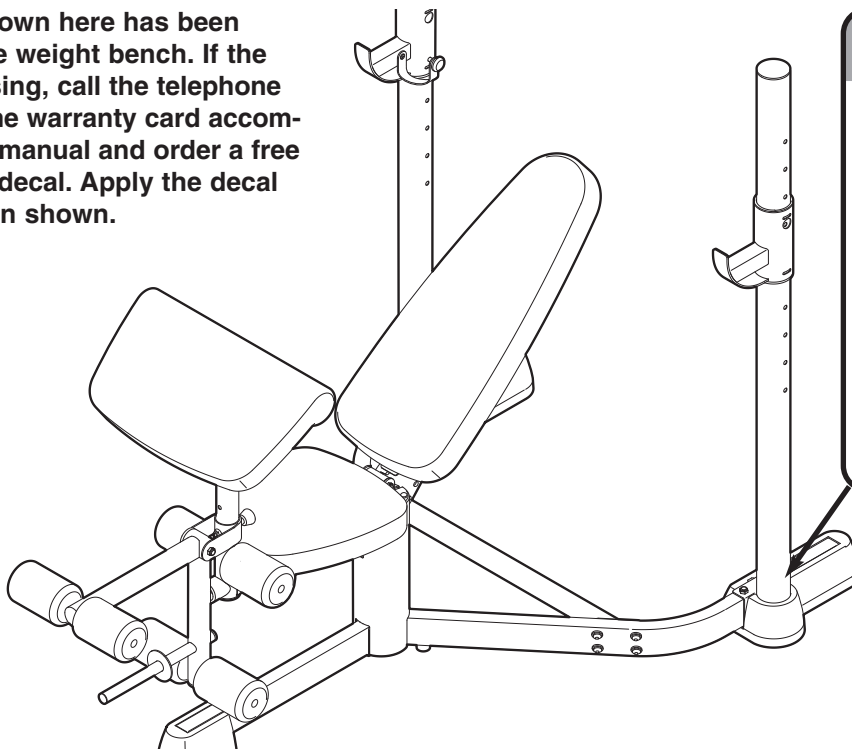

▲WARNING

- Misuse of this machine may result in serious injury.
- Read user's manual prior to use and follow all warnings and instructions.
- Do not allow children on or around machine.
- Keep body, clothing, and hair free and clear of all moving parts.
- Replace label if damaged, illegible, or removed.

IMPORTANT PRECAUTIONS

⚠️ WARNING: To reduce the risk of serious injury, read the following important precautions before using the weight bench.

1. Read all instructions in this manual and all warnings on the weight bench before using the weight bench. Use the weight bench only as described in this manual.
2. It is the responsibility of the owner to ensure that all users of the weight bench are adequately informed of all precautions.
3. The weight bench is intended for home use only. Do not use the weight bench in any commercial, rental, or institutional setting.
4. Keep the weight bench indoors, away from moisture and dust. Place the weight bench on a level surface, with a mat beneath it to protect the floor or carpet. Make sure that there is enough clearance around the weight bench to mount, dismount, and use the weight bench.
5. Inspect and properly tighten all parts regularly. Replace any worn parts immediately.
6. Keep hands and feet away from moving parts.
7. Keep children under 12 and pets away from the weight bench at all times.
8. Always wear athletic shoes for foot protection while exercising.
9. The weight bench is designed to support a maximum of 610 pounds, including a maximum user weight of 300 pounds. Do not place more than 310 pounds, including the barbell, on the weight rests. Do not place more than 150 pounds of weight on the leg lever. Note: The weight bench does not include a barbell or weights.
10. Always make sure that the locking pin is fully inserted into the pivot bracket and the frame before exercising.
11. If you feel pain or dizziness while exercising, stop immediately and begin cooling down.

⚠️ WARNING: Before beginning this or any exercise program, consult your physician. This is especially important for persons over the age of 35 or persons with pre-existing health problems. Read all instructions before using. ICON assumes no responsibility for personal injury or property damage sustained by or through the use of this product.

BEFORE YOU BEGIN

Thank you for selecting the versatile PROFORM® XP 160 weight bench. The weight bench is designed to help develop every major muscle group of the body. Whether your goal is to tone your body, build dramatic muscle size and strength, or improve your cardiovascular system, the weight bench will help you to achieve the specific results you want.

For your benefit, read this manual carefully before using the weight bench. If you have questions after reading this manual, call the telephone number on the

warranty card accompanying this manual. To help us assist you, please note the product model number and serial number before calling. The model number is PFANBE2525.0. The serial number can be found on a decal attached to the weight bench (see the front cover of this manual).

Before reading further, please review the drawing below and familiarize yourself with the parts that are labeled.

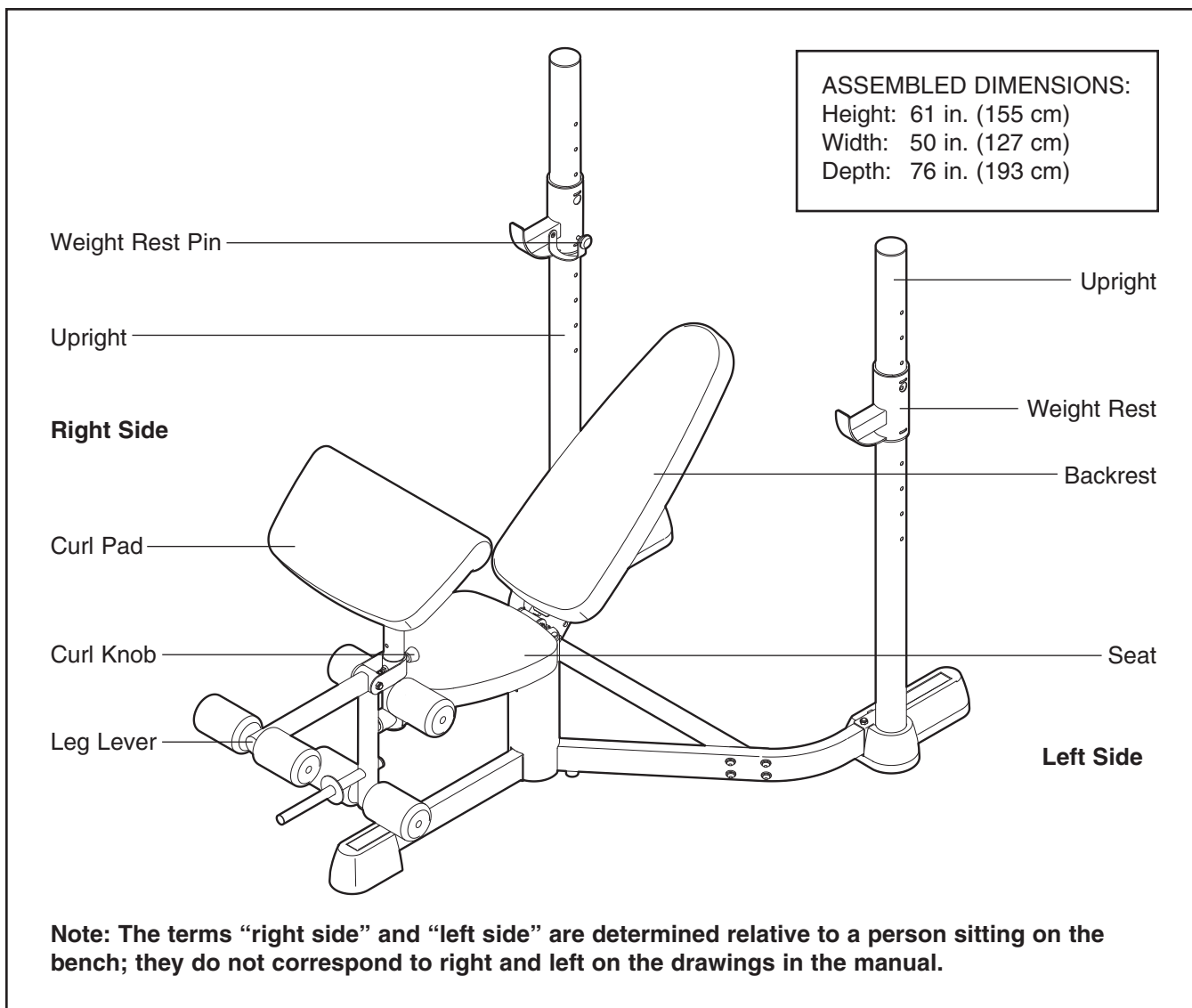

ASSEMBLY

Make Assembly Easier

Everything in this manual is designed to ensure that the weight bench can be assembled successfully by anyone. Most people find that by setting aside plenty of time, assembly will go smoothly.



Before beginning assembly, carefully read the following information and instructions:

- Assembly requires two people.
- Make sure that there is enough clearance to walk around the weight bench as you assemble it.
- Place all parts in a cleared area and remove the packing materials. Do not dispose of the packing materials until assembly is completed.
- As you assemble the weight bench, make sure all parts are oriented as shown in the drawings.

- Tighten all parts as you assemble them, unless instructed to do otherwise.

- **For help identifying small parts, use the PART IDENTIFICATION CHART.**

The included hex keys  and the following tools (not included) may be required for assembly:

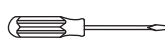
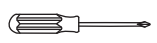
- Two adjustable wrenches 
- One rubber mallet 
- One standard screwdriver 
- One Phillips screwdriver 
- Clear tape or masking tape, and soapy water.

Assembly will be more convenient if you have a socket set, a set of open-end or closed-end wrenches, or a set of ratchet wrenches.

1. Attach a Seat Base Bumper (31) to the Left Base (33) with an M4 x 16mm Self-tapping Screw (38) and an M4 Washer (39).

The Uprights (4) can be assembled at an Olympic width or a mid-width.

For an Olympic width, attach an Upright (4) to the outside of the Left Base (33) with an M10 x 55mm Button Bolt (47) and an M10 Washer (37); and with two M10 x 95mm Button Bolts (46) and two M10 Nylon Locknuts (41).

Attach the Left Foot (16) to the Left Base (33) with two M4 x 16mm Self-tapping Screws (38) and two M4 Washers (39).

For a Mid-width, attach an Upright (4) to the inside of the Left Base (33) as described above (see the inset drawing). Then attach the Right Foot (17) to the Left Base as described above.

Repeat this step with the Right Base (not shown). Make sure that the Right Base is oriented as shown in step 3.

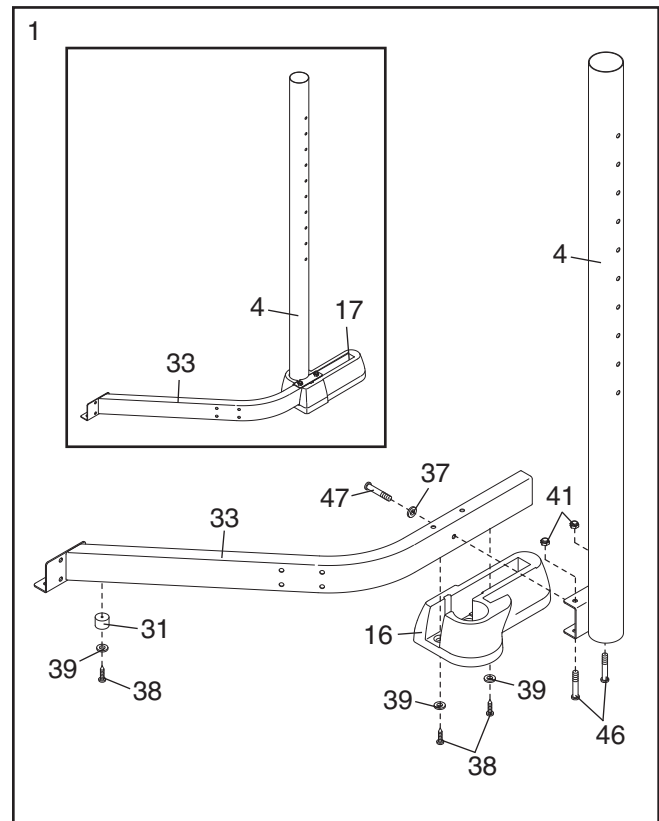

2. Attach the Front Foot (15) to the Seat Base (1) with two M4 x 16mm Self-tapping Screws (38) and two M4 Washers (39).

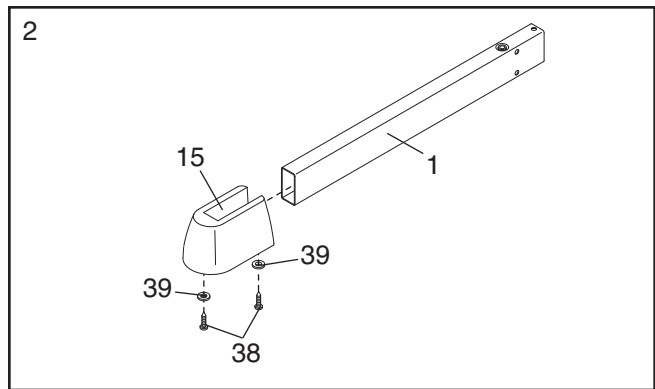

3. Attach the Right and Left Bases (2, 33) to the Seat Base (1) with two M10 x 58mm Button Bolts (48) and two M10 Nylon Locknuts (41). **Do not tighten the Nylon Locknuts yet.**

Insert two M10 x 100mm Screws (45) up through the Base Plate (34) and the Seat Base (1). **Place a piece of tape over the Bolt heads to hold them in place.**

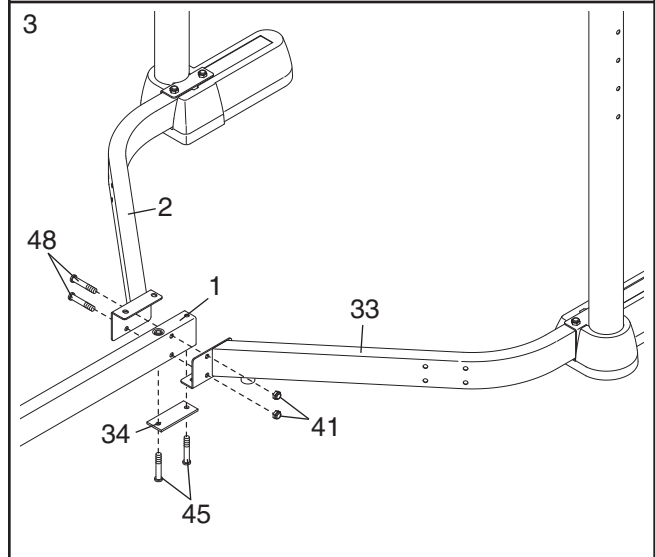

4. Orient the Center Base (3) as shown and attach it to the Right and Left Bases (2, 33) with eight M10 x 55mm Button Bolts (47), eight M10 Washers (37), and eight M10 Nylon Locknuts (41).

See step 3. Tighten the M10 Nylon Locknuts (41) used in step 3.

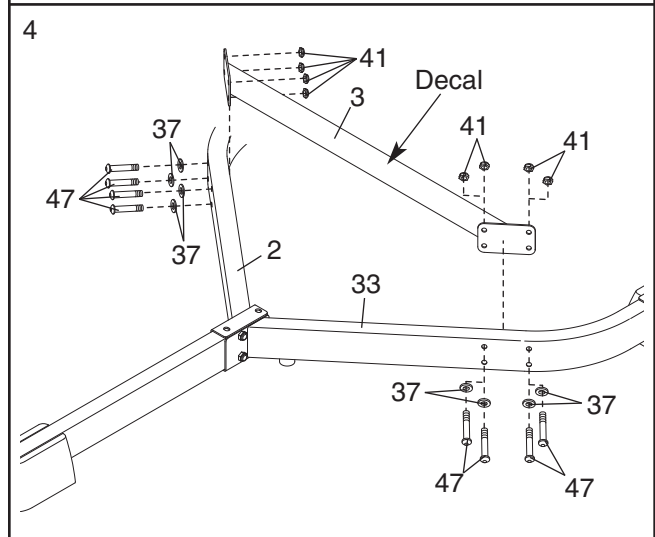

- Attach the Seat Frame (5) to the Seat Base (1) with the indicated two M10 x 100mm Screws (45).

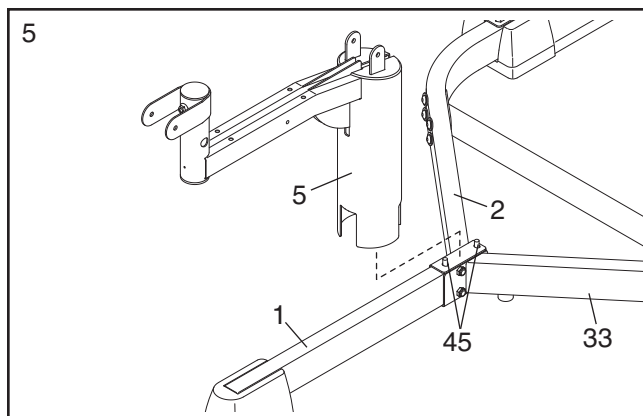

- Attach the Backrest (11) to the Backrest Frame (8) with four M6 x 15mm Button Screws (40).

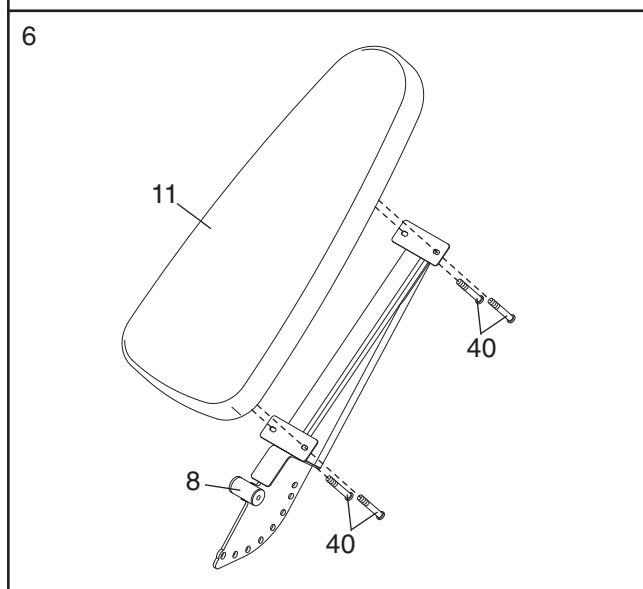

- Grease the M10 x 87mm Button Bolt (50). Attach the Backrest Frame (8) to the Seat Frame (5) with the Bolt and an M10 Nylon Locknut (41). **Do not overtighten the Nylon Locknut; the Backrest Frame must be able to pivot easily.**

Engage the Backrest Frame (8) with the Backrest Knob (22) and fully tighten the Knob into the Seat Frame (5).

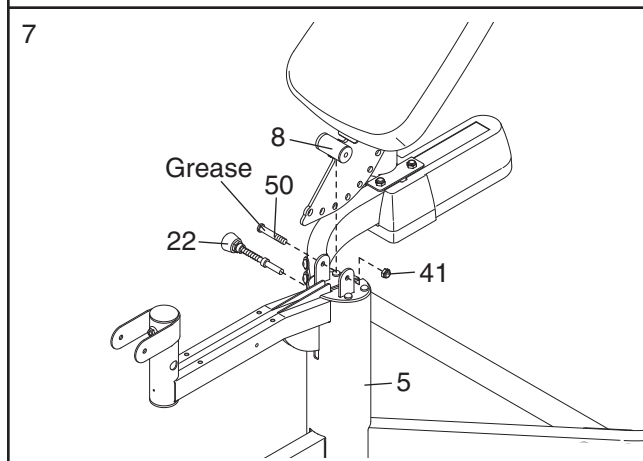

- Attach the Seat Bumper (27) to the Seat Frame (5) with an M4 x 16mm Self-tapping Screw (38) and an M4 Washer (39).

Grease an M10 x 82mm Button Bolt (49). Attach the Leg Lever (6) to the Seat Frame (5) with the Bolt and an M10 Nylon Locknut (41). **Do not overtighten the Nylon Locknut; the Leg Lever must be able to pivot easily.**

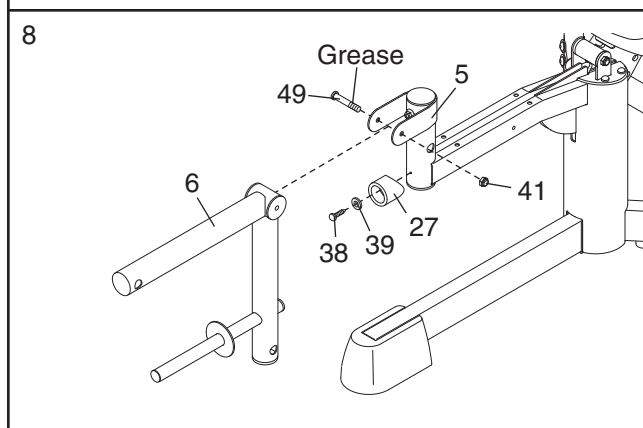

9. Attach the Seat (12) to the Seat Frame (5) with four M6 x 63mm Button Screws (43) and four M6 Washers (44).

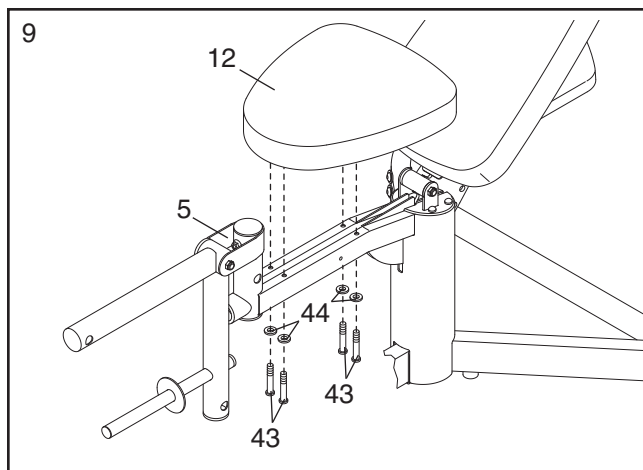

10. Insert a Pad Tube (10) into the Leg Lever (6). Slide two Foam Pads (14) onto the Pad Tube.

Assemble the other two Pad Tubes (10) to the Leg Lever (6) and the Seat Frame (5) in the same manner.

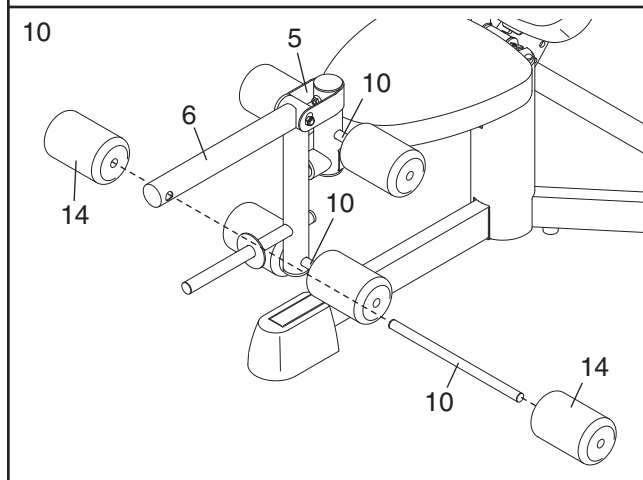

11. Attach a Weight Rest Pin (24) to the Left Weight Rest (42) with an M4 x 16mm Self-tapping Screw (38).

Slide the Left Weight Rest (42) onto the indicated Upright (4) and engage the Weight Rest Pin (24) into the Weight Rest and Upright.

Repeat this step with the Right Weight Rest (9) and other Upright (4). Set both Weight Rests at the same height.

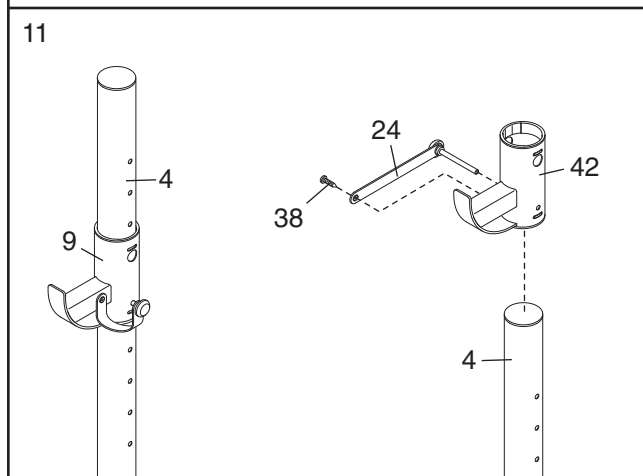

12. Attach the Curl Pad (13) to the Curl Post (7) with two M6 x 15mm Button Screws (40).

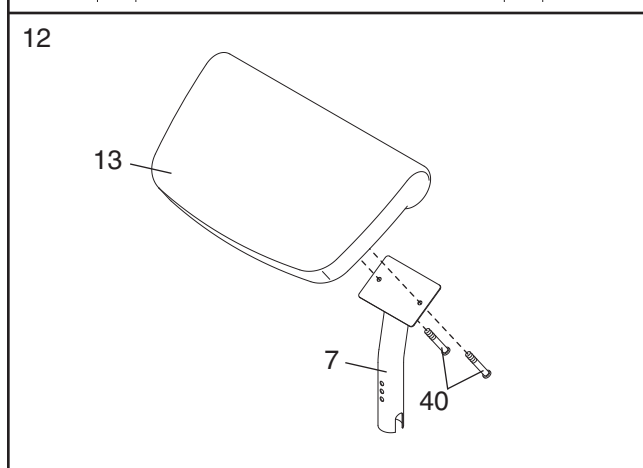

13. Make sure that all parts have been properly tightened. The use of the remaining parts will be explained in ADJUSTMENTS, beginning on the next page.

ADJUSTMENTS

This section explains how to adjust the weight bench. See the EXERCISE GUIDELINES on page 10 for important information about how to get the most benefit from your exercise program. Also, refer to the accompanying exercise guide to see the correct form for each exercise.

Make sure all parts are properly tightened each time the weight bench is used. Replace any worn parts immediately. The weight bench can be cleaned with a damp cloth and a mild, non-abrasive detergent. Do not use solvents.

ATTACHING THE CURL PAD

To use the Curl Pad (13), first remove the 56mm Round Cap (20) from the Seat Frame (5). Then insert the Curl Post (7) into the Seat Frame and secure it with the Curl Knob (23).

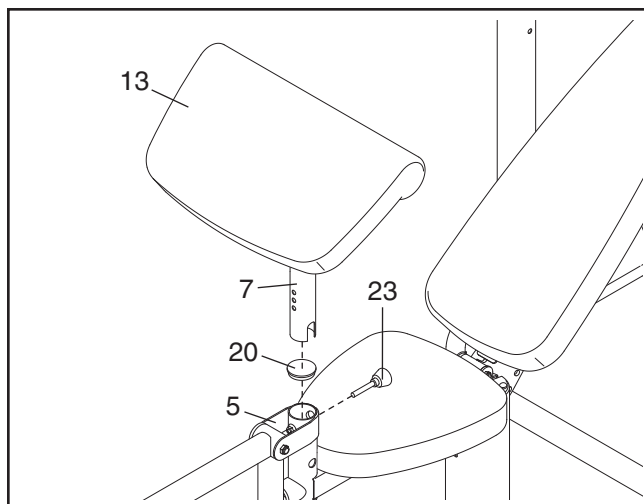

ADJUSTING THE BACKREST

To adjust the Backrest (11), pull the Backrest Knob (22, not shown) out and move the Backrest to the desired position. Reengage the Knob into the Backrest Frame (8).

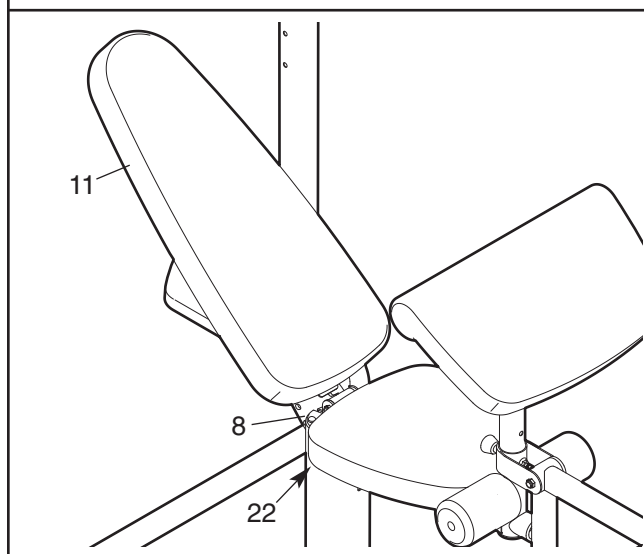

ADJUSTING THE WEIGHT RESTS

To adjust the Right Weight Rest (9), remove the Weight Rest Pin (24) from the Upright (4). Raise or lower the Weight Rest to the desired height and engage the Pin into the Weight Rest and Upright.

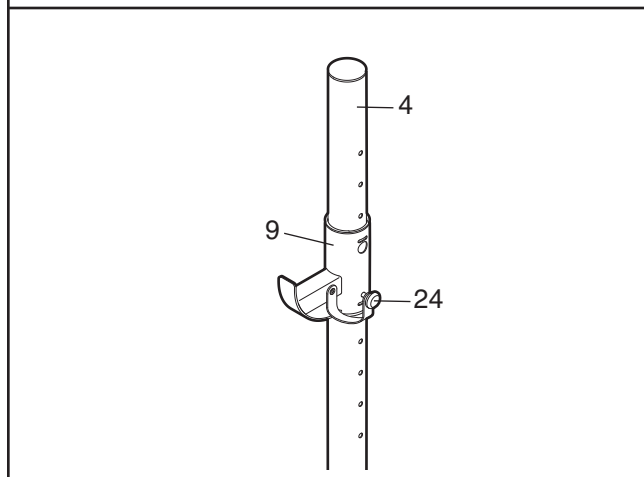

⚠ WARNING: Always adjust both Weight Rests (9, 42) to the same height before exercising.

ATTACHING WEIGHTS

To use the Leg Lever (6), slide the desired weight (not included) onto the weight tube. Secure the weight with the Spring Clip (35).

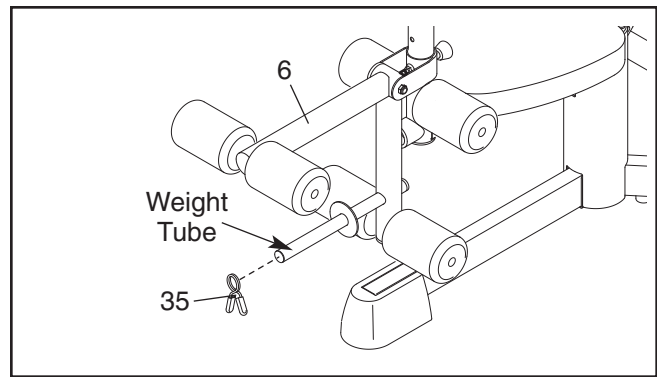

EXERCISE GUIDELINES

THE FOUR BASIC TYPES OF WORKOUTS

Muscle Building

To increase the size and strength of your muscles, push them close to their maximum capacity. Your muscles will adapt and grow as you progressively increase the intensity of your exercise. You can adjust the intensity level of an individual exercise in two ways:

- by changing the amount of weight used
- by changing the number of repetitions or sets performed. (A “repetition” is one complete cycle of an exercise, such as one sit-up. A “set” is a series of repetitions.)

The proper amount of weight for each exercise depends upon the individual user. You must gauge your limits and select the amount of weight that is right for you. Begin with 3 sets of 8 repetitions for each exercise you perform. Rest for 3 minutes after each set. When you can complete 3 sets of 12 repetitions without difficulty, increase the amount of weight.

Toning

You can tone your muscles by pushing them to a moderate percentage of their capacity. Select a moderate amount of weight and increase the number of repetitions in each set. Complete as many sets of 15 to 20 repetitions as possible without discomfort. Rest for 1 minute after each set. Work your muscles by completing more sets rather than by using high amounts of weight.

Weight Loss

To lose weight, use a low amount of weight and increase the number of repetitions in each set. Exercise for 20 to 30 minutes, resting for a maximum of 30 seconds between sets.

Cross Training

Cross training is an efficient way to get a complete and well-balanced fitness program. An example of a balanced program is:

- Plan strength training workouts on Monday, Wednesday, and Friday.
- Plan 20 to 30 minutes of aerobic exercise, such as running on a treadmill or riding on an exercise cycle or an elliptical exerciser, on Tuesday and Thursday.
- Rest from both strength training and aerobic exercise for at least one full day each week to give your body time to regenerate.

The combination of strength training and aerobic exercise will reshape and strengthen your body, plus develop your heart and lungs.

PERSONALIZING YOUR EXERCISE PROGRAM

Determining the appropriate length of time for each workout, and the numbers of repetitions or sets to complete, is an individual matter. It is important to avoid overdoing it during the first few months of your exercise program. Progress at your own pace and be sensitive to your body's signals. If you experience pain or dizziness at any time while exercising, stop immediately and begin cooling down. Find out what is wrong before continuing. Remember that adequate rest and a proper diet are important factors in any exercise program.

WARMING UP

Begin each workout with 5 to 10 minutes of stretching and light exercise to warm up. Warming up prepares your body for more strenuous exercise by increasing circulation, raising your body temperature and delivering more oxygen to your muscles.

WORKING OUT

Each workout should include 6 to 10 different exercises. Select exercises for every major muscle group, emphasizing areas that you want to develop most. To give balance and variety to your workouts, vary the exercises from session to session.

Schedule your workouts for the time of day when your energy level is the highest. Each workout should be followed by at least one day of rest. Once you find the schedule that is right for you, stick with it.

EXERCISE FORM

Maintaining proper form is an essential part of an effective exercise program. This requires moving through the full range of motion for each exercise, and moving only the appropriate parts of the body. Exercising in an uncontrolled manner will leave you feeling exhausted. On the exercise guide accompanying this manual you will find photographs showing the correct form for several exercises, and a list of the muscles affected. Refer to the muscle chart on the next page to find the names of the muscles.

The repetitions in each set should be performed smoothly and without pausing. The exertion stage of each repetition should last about half as long as the return stage. Proper breathing is important. Exhale during the exertion stage of each repetition and inhale during the return stroke. Never hold your breath.

Rest for a short period of time after each set. The ideal resting periods are:

- Rest for three minutes after each set for a muscle building workout.
- Rest for one minute after each set for a toning workout.
- Rest for 30 seconds after each set for a weight loss workout.

Plan to spend the first couple of weeks familiarizing yourself with the equipment and learning the proper form for each exercise.

COOLING DOWN

End each workout with 5 to 10 minutes of stretching. Include stretches for both your arms and legs. Move slowly as you stretch and do not bounce. Ease into each stretch gradually and go only as far as you can without strain. Stretching at the end of each workout is an effective way to increase flexibility.

STAYING MOTIVATED

For motivation, keep a record of each workout. List the date, the exercises performed, the resistance used, and the numbers of sets and repetitions completed. Record your weight and key body measurements at the end of every month. Remember, the key to achieving the greatest results is to make exercise a regular and enjoyable part of your everyday life.

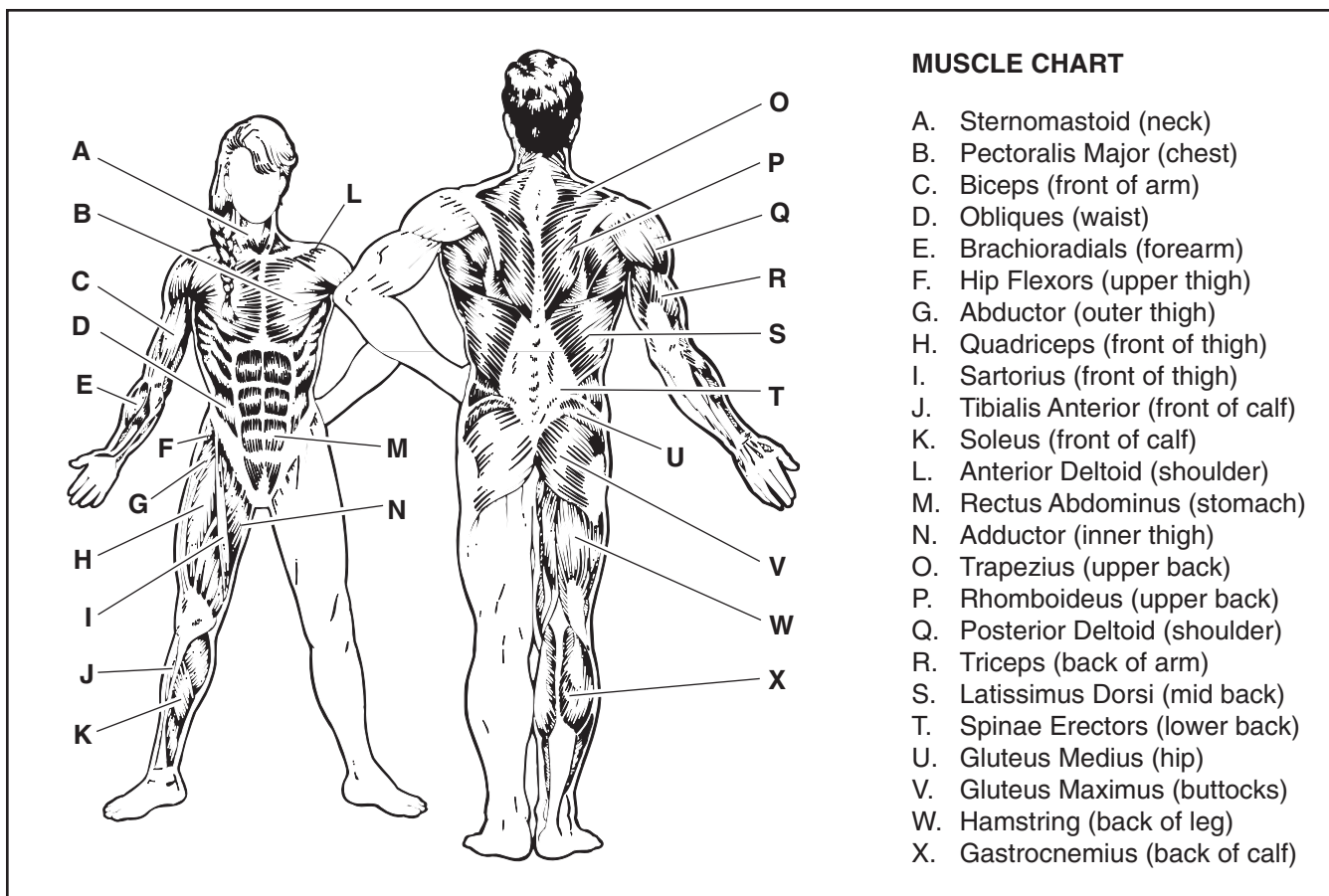

MUSCLE CHART

- A. Sternomastoid (neck)
- B. Pectoralis Major (chest)
- C. Biceps (front of arm)
- D. Obliques (waist)
- E. Brachioradialis (forearm)
- F. Hip Flexors (upper thigh)
- G. Abductor (outer thigh)
- H. Quadriceps (front of thigh)
- I. Sartorius (front of thigh)
- J. Tibialis Anterior (front of calf)
- K. Soleus (front of calf)
- L. Anterior Deltoid (shoulder)
- M. Rectus Abdominus (stomach)
- N. Adductor (inner thigh)
- O. Trapezius (upper back)
- P. Rhomboideus (upper back)
- Q. Posterior Deltoid (shoulder)
- R. Triceps (back of arm)
- S. Latissimus Dorsi (mid back)
- T. Spinae Erectors (lower back)
- U. Gluteus Medius (hip)
- V. Gluteus Maximus (buttocks)
- W. Hamstring (back of leg)
- X. Gastrocnemius (back of calf)

PART IDENTIFICATION CHART

Refer to the drawings below to identify small parts used in assembly. The number in parentheses by each drawing is the key number of the part, from the PART LIST in the center of this manual. **Note: Some small parts may have been pre-attached. If a part is not in the parts bag, check to see if it has been preattached.**

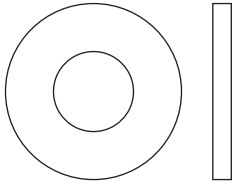

M10 Washer (37)



M6 Washer (44)



M4 Washer (39)

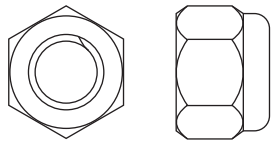

M10 Nylon Locknut (41)

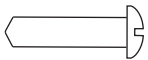

M4 x 16mm Self-tapping Screw (38)

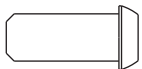

M6 x 15mm Button Screw (40)

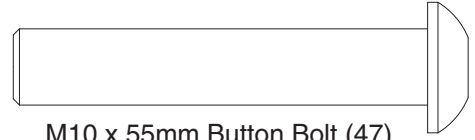

M10 x 55mm Button Bolt (47)

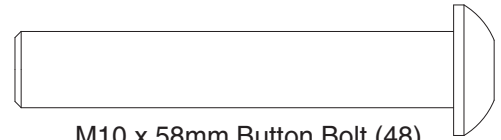

M10 x 58mm Button Bolt (48)

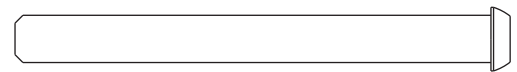

M6 x 63mm Button Screw (43)

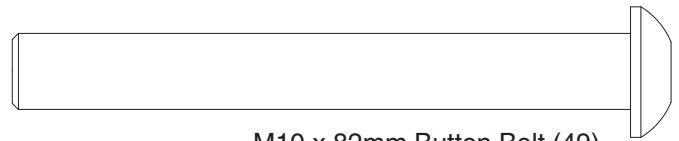

M10 x 82mm Button Bolt (49)

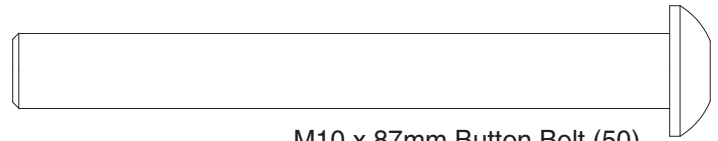

M10 x 87mm Button Bolt (50)

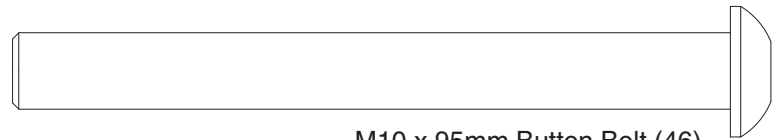

M10 x 95mm Button Bolt (46)

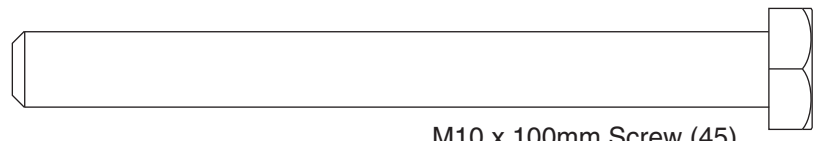

M10 x 100mm Screw (45)

**MAKE ASSEMBLY EASIER. REMOVE AND USE THIS
PART IDENTIFICATION CHART AND PART
LIST/EXPLODED DRAWING DURING ASSEMBLY.**

**SAVE THIS PART IDENTIFICATION CHART
PART LIST/EXPLODED DRAWING FOR FUTURE REFERENCE**

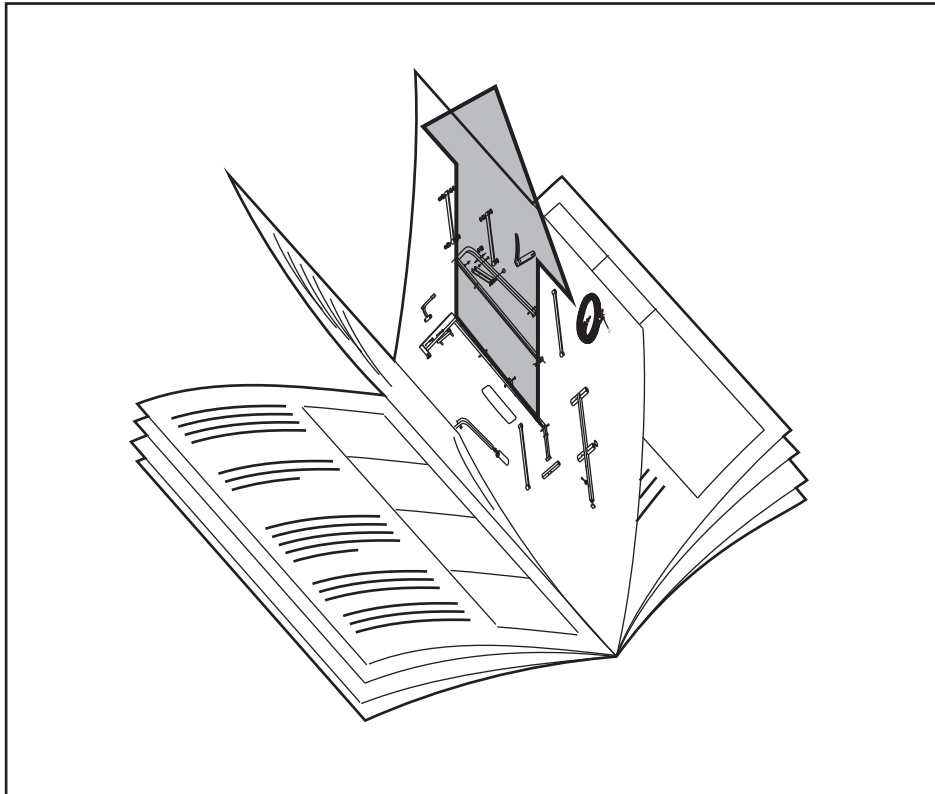

PART LIST—Model No. PFANBE2525.0

R0906A

Key No.	Qty.	Description	Key No.	Qty.	Description
1	1	Seat Base	28	2	Backrest Frame Bushing
2	1	Right Base	29	2	Leg Lever Bushing
3	1	Center Base	30	2	25mm Round Cap
4	2	Upright	31	2	Seat Base Bumper
5	1	Seat Frame	32	1	Right Seat Cap
6	1	Leg Lever	33	1	Left Base
7	1	Curl Post	34	1	Base Plate
8	1	Backrest Frame	35	1	Spring Clip
9	1	Right Weight Rest	36	1	25mm x 50mm Inner Cap
10	3	Pad Tube	37	10	M10 Washer
11	1	Backrest	38	15	M4 x 16mm Self-tapping Screw
12	1	Seat	39	9	M4 Washer
13	1	Curl Pad	40	6	M6 x 15mm Button Screw
14	6	Foam Pad	41	16	M10 Nylon Locknut
15	1	Front Foot	42	1	Left Weight Rest
16	1	Left Foot	43	4	M6 x 63mm Button Screw
17	1	Right Foot	44	4	M6 Washer
18	2	76mm Round Cap	45	2	M10 x 100mm Screw
19	2	50mm Round Cap	46	4	M10 x 95mm Button Bolt
20	2	56mm Round Cap	47	10	M10 x 55mm Button Bolt
21	1	Left Seat Cap	48	2	M10 x 58mm Button Bolt
22	1	Backrest Knob	49	1	M10 x 82mm Button Bolt
23	1	Curl Knob	50	1	M10 x 87mm Button Bolt
24	2	Weight Rest Pin	#	—	User's Manual
25	6	19mm Round Inner Cap	#	—	Hex Key
26	4	Weight Rest Bushing	#	—	Grease Pack
27	1	Seat Bumper	#	—	Exercise Guide

Note: “#” indicates a non-illustrated part. Specifications are subject to change without notice. See the back cover of this manual for information about ordering replacement parts.

EXPLODED DRAWING—Model No. PFANBE2525.0

R0906A

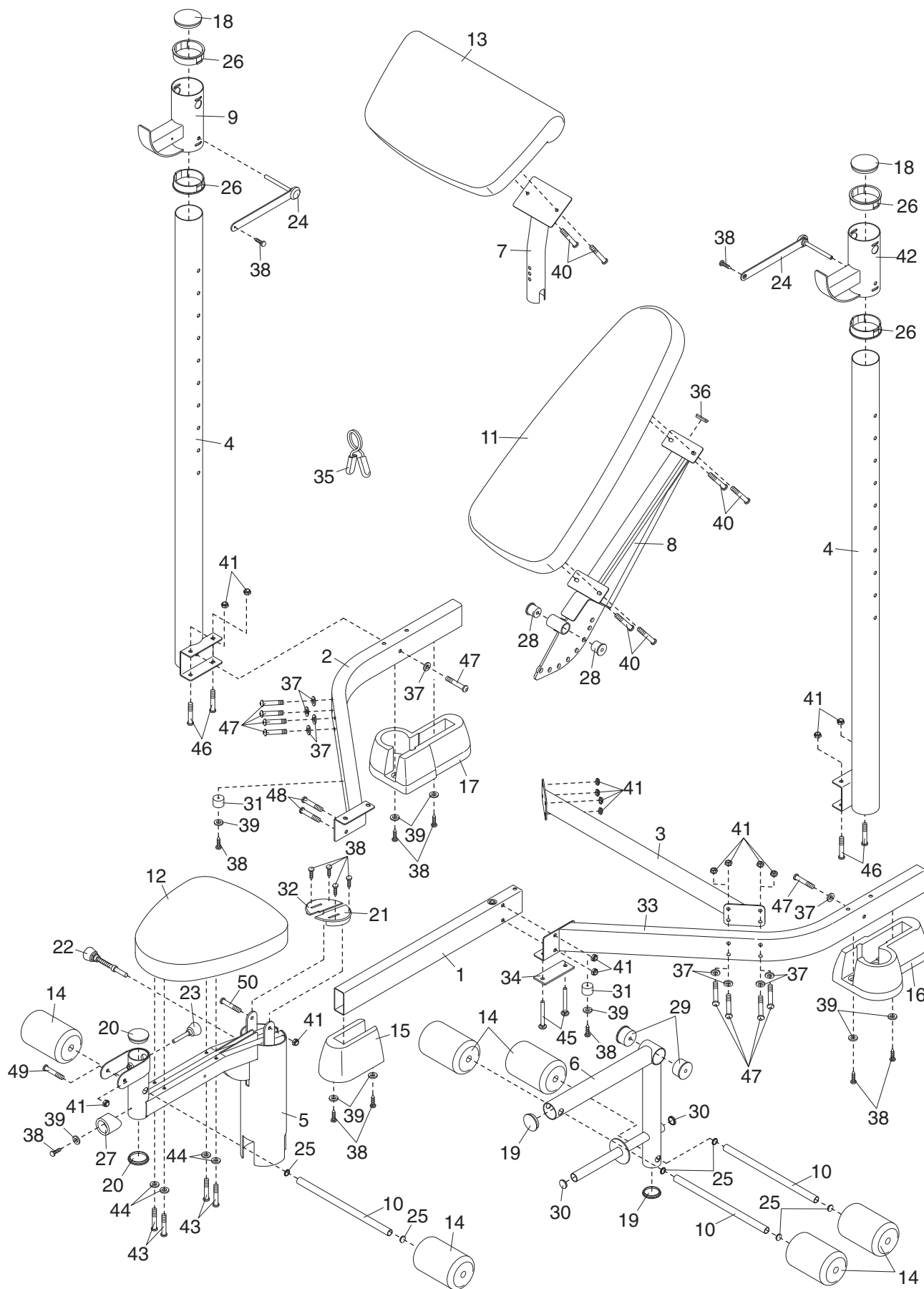

ORDERING REPLACEMENT PARTS

To order replacement parts, please call the telephone number on the warranty card accompanying this manual. To help us assist you, be prepared to provide the following information:

- the MODEL NUMBER of the product (PFANBE2525.0)
- the NAME of the product (PROFORM XP 160 weight bench)
- the SERIAL NUMBER of the product (see the front cover of this manual)
- the KEY NUMBER and DESCRIPTION of the part(s) (see the PART LIST and EXPLODED DRAWING in the center of this manual)

Free Manuals Download Website

<http://myh66.com>

<http://usermanuals.us>

<http://www.somanuals.com>

<http://www.4manuals.cc>

<http://www.manual-lib.com>

<http://www.404manual.com>

<http://www.luxmanual.com>

<http://aubethermostatmanual.com>

Golf course search by state

<http://golfingnear.com>

Email search by domain

<http://emailbydomain.com>

Auto manuals search

<http://auto.somanuals.com>

TV manuals search

<http://tv.somanuals.com>