

PRO-FORM[®]

680 MRT

www.proform.com

Model No. PMTL39708.0

Serial No. _____

Write the serial number in the space above for future reference.

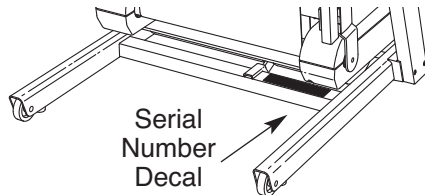

USER'S MANUAL

QUESTIONS?

If you have questions, or if parts are damaged or missing, **DO NOT CONTACT THE STORE**; please contact Customer Care.

IMPORTANT: Please register this product (see the limited warranty on the back cover of this manual) before contacting Customer Care.

CALL TOLL-FREE:

1-888-533-1333

Mon.–Fri. 6 a.m.–6 p.m. MT

Sat. 8 a.m.–4 p.m. MT

ON THE WEB:

www.proformservice.com

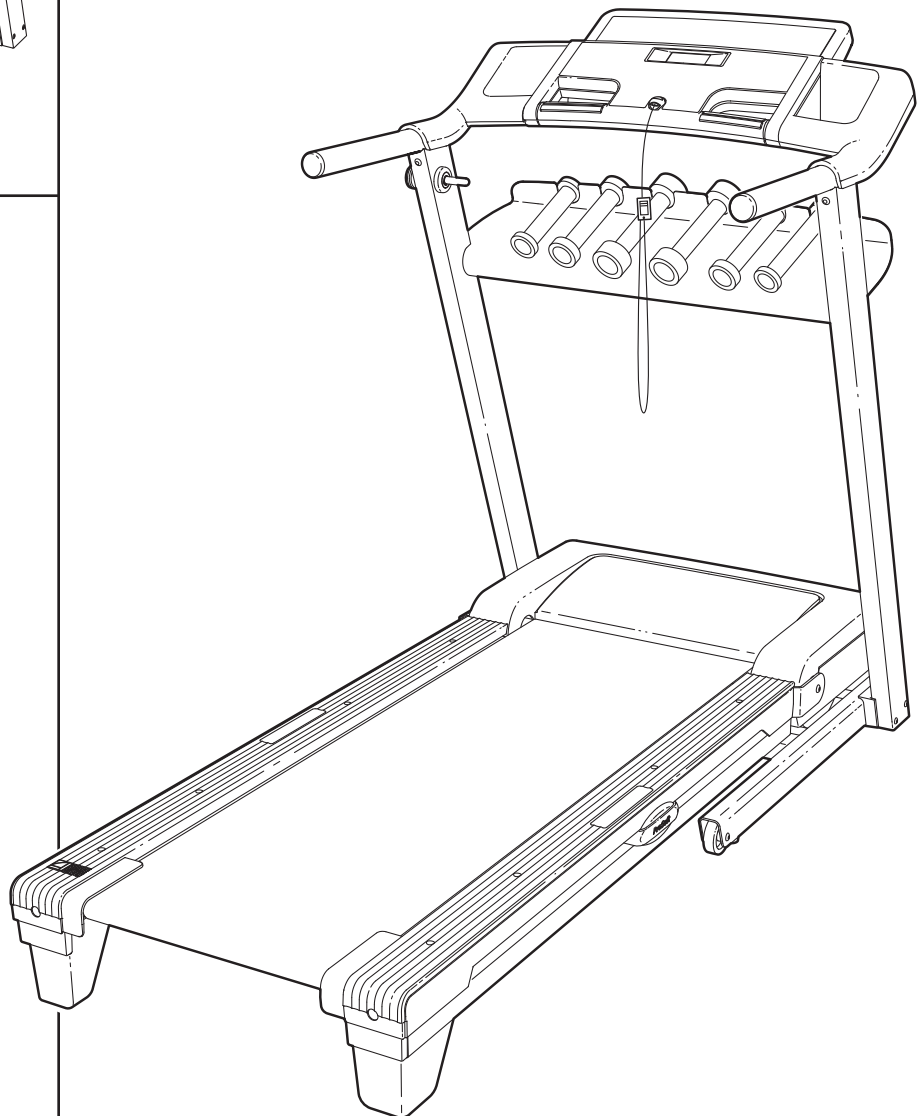

CAUTION

Read all precautions and instructions in this manual before using this equipment. Save this manual for future reference.



TABLE OF CONTENTS

WARNING DECAL PLACEMENT	2
IMPORTANT PRECAUTIONS	3
BEFORE YOU BEGIN	5
ASSEMBLY	6
OPERATION AND ADJUSTMENT	13
HOW TO FOLD AND MOVE THE TREADMILL	19
TROUBLESHOOTING	21
EXERCISE GUIDELINES	24
PART LIST	26
EXPLODED DRAWING	28
ORDERING REPLACEMENT PARTS	Back Cover
LIMITED WARRANTY	Back Cover

WARNING DECAL PLACEMENT

This drawing shows the locations of the warning decals. **If a decal is missing or illegible, please see the front cover of this manual and request a free replacement decal. Apply the decal in the location shown.** Note: The decals may not be shown at actual size.

⚠ CAUTION

KEEP HANDS AND FEET AWAY FROM THIS AREA WHILE THE TREADMILL IS IN OPERATION.

⚠ PRECAUCIÓN

Mantenga sus manos y pies alejados de esta area mientras la caminadora esté en operación.

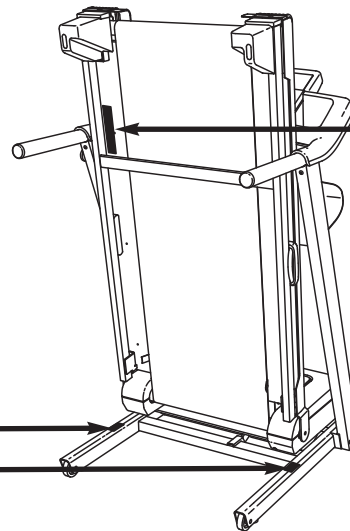

⚠ WARNING:

Protect yourself and others from risk of serious injury. Read the user's manual and:

- Stand only on the side rails when starting or stopping treadmill.
- Change speed in small increments.
- Hold handrails to prevent falling, and always wear the safety clip while operating treadmill.
- Stop if you feel faint, dizzy, or short of breath.
- Fully engage storage latch before treadmill is moved or stored.
- Reduce incline to its lowest level before folding treadmill into storage position.

• Never allow children on or around treadmill.

• Remove key when not in use.

• Keep clothing, fingers, and hair away from moving belt.

• Never try to adjust or fix the belt while it is moving.

• Always wear athletic shoes while operating treadmill.

⚠ ADVERTENCIA:

Protéjase y proteja a otros de riesgo de lesiones serias. Lea el manual del usuario y:

- Párese solo en los rieles de soporte para los pies al comenzar o para la cinta de correr.
- Cambie la velocidad en aumentos pequeños.
- Sostenga las barandas para prevenir caídas, y siempre porte el sujetador mientras opera la cinta de correr.
- Pásele a la cinta de correr débil, mareado o corto de aliento.
- Enganche el seguro de almacenamiento completamente antes que la cinta de correr se mueva o se gaste.
- Reduzca la inclinación al nivel más bajo antes de doblar la cinta de correr a la posición de almacenamiento.

• Nunca permita a los niños en o alrededor de la cinta de correr.

• Quite la llave cuando no este en uso.

• Mantenga ropa, dedos, y cabello lejos de la banda en movimiento.

• Nunca trate de ajustar o arreglar la banda mientras que se este movimiento.

• Siempre use zapatos atléticos mientras opera la cinta de correr.

IMPORTANT PRECAUTIONS

⚠ WARNING: To reduce the risk of serious injury, read all important precautions and instructions in this manual and all warnings on your treadmill before using your treadmill. ICON assumes no responsibility for personal injury or property damage sustained by or through the use of this product.

1. Before beginning any exercise program, consult your physician. This is especially important for persons over age 35 or persons with pre-existing health problems.
2. It is the responsibility of the owner to ensure that all users of this treadmill are adequately informed of all warnings and precautions. Use the treadmill only as described.
3. Place the treadmill on a level surface, with at least 8 ft. (2.4 m) of clearance behind it and 2 ft. (0.6 m) on each side. Do not place the treadmill on any surface that blocks air openings. To protect the floor or carpet from damage, place a mat under the treadmill.
4. Keep the treadmill indoors, away from moisture and dust. Do not put the treadmill in a garage or covered patio, or near water.
5. Do not operate the treadmill where aerosol products are used or where oxygen is being administered.
6. Keep children under age 12 and pets away from the treadmill at all times.
7. The treadmill should be used only by persons weighing 250 lbs. (113 kg) or less.
8. Never allow more than one person on the treadmill at a time.
9. Wear appropriate exercise clothes while using the treadmill. Do not wear loose clothes that could become caught in the treadmill. Athletic support clothes are recommended for both men and women. *Always wear athletic shoes; never use the treadmill with bare feet, wearing only stockings, or in sandals.*
10. When connecting the power cord (see page 13), plug the power cord into a surge suppressor (not included) and plug the surge suppressor into a grounded circuit capable of carrying 15 or more amps. No other appliance should be on the same circuit. Do not use an extension cord.
11. Use only a single-outlet surge suppressor that meets all of the specifications described on page 13. To purchase a surge suppressor, please see the front cover of this manual, or see your local electronics store.
12. Failure to use a properly functioning surge suppressor could result in damage to the control system of the treadmill. If the control system is damaged, the walking belt may slow, accelerate, or stop unexpectedly, which may result in a fall and serious injury.
13. Keep the power cord and the surge suppressor away from heated surfaces.
14. Never move the walking belt while the power is turned off. Do not operate the treadmill if the power cord or plug is damaged, or if the treadmill is not working properly. (See TROUBLESHOOTING on page 21 if the treadmill is not working properly.)
15. Read, understand, and test the emergency stop procedure before using the treadmill (see HOW TO TURN ON THE POWER on page 15).
16. Never start the treadmill while you are standing on the walking belt. Always hold the handrails while using the treadmill.
17. The treadmill is capable of high speeds. Adjust the speed in small increments to avoid sudden jumps in speed.
18. The pulse sensor is not a medical device. Various factors, including the user's movement, may affect the accuracy of heart rate readings. The pulse sensor is intended only as an exercise aid in determining heart rate trends in general.

19. Use the included dumbbells only as described in this manual. Properly store the dumbbells in the dumbbell rack when you are not using them. If the dumbbells are improperly stored, they may fall off the rack, causing the user to trip.
20. Never leave the treadmill unattended while it is running. Always remove the key, unplug the power cord, and switch the reset/off circuit breaker to the off position when the treadmill is not in use. (See the drawing on page 5 for the location of the circuit breaker.)
21. Do not attempt to raise, lower, or move the treadmill until it is properly assembled. (See ASSEMBLY on page 6, and HOW TO FOLD AND MOVE THE TREADMILL on page 19.) You must be able to safely lift 45 lbs. (20 kg) to raise, lower, or move the treadmill.
22. When folding or moving the treadmill, make sure that the storage latch is holding the frame securely in the storage position.
23. Never insert any object into any opening on the treadmill.
24. Inspect and properly tighten all parts of the treadmill regularly.
25. **DANGER:** Always unplug the power cord immediately after use, before cleaning the treadmill, and before performing the maintenance and adjustment procedures described in this manual. Never remove the motor hood unless instructed to do so by an authorized service representative. Servicing other than the procedures in this manual should be performed by an authorized service representative only.
26. This treadmill is intended for in-home use only. Do not use this treadmill in a commercial, rental, or institutional setting.

SAVE THESE INSTRUCTIONS

BEFORE YOU BEGIN

Thank you for selecting the new PROFORM® 680 MRT treadmill. The 680 MRT treadmill offers a selection of features designed to make your workouts at home more effective. And when you're not exercising, the unique treadmill can be folded up, requiring less than half the floor space of other treadmills.

For your benefit, read this manual carefully before using the treadmill. If you have questions after read-



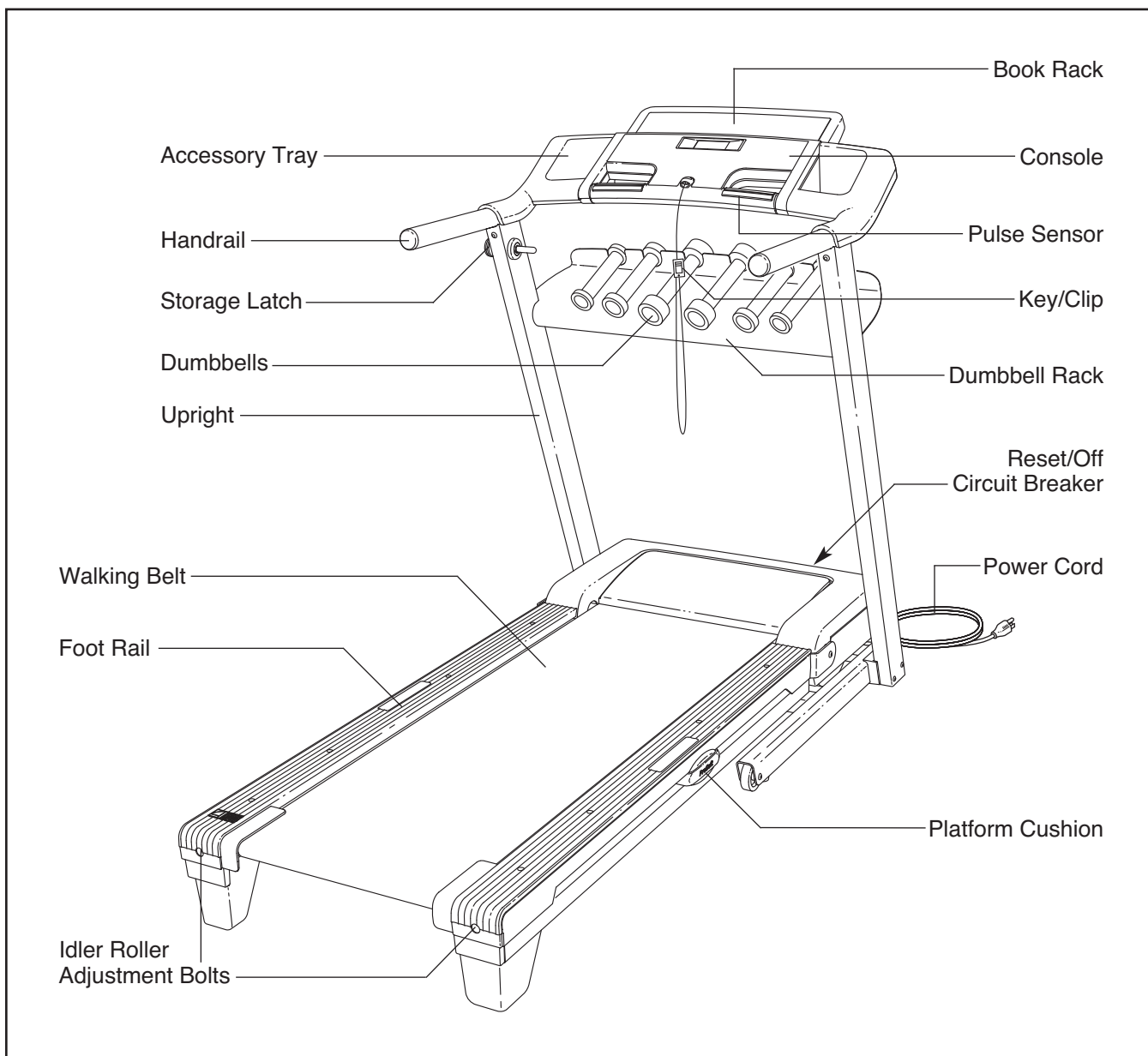

ing this manual, please see the front cover of this manual. To help us assist you, please note the product model number and serial number before contacting us. The model number and the location of the serial number decal are shown on the front cover of this manual.

Before reading further, please review the drawing below and familiarize yourself with the labeled parts.



ASSEMBLY

Assembly requires two persons. Set the treadmill in a cleared area and remove all packing materials. **Do not dispose of the packing materials until assembly is completed.** Note: The underside of the treadmill walking belt is coated with high-performance lubricant. During shipping, a small amount of lubricant may be transferred to the top of the walking belt or the shipping carton. This is a normal condition and does not affect treadmill performance. If there is lubricant on top of the walking belt, simply wipe off the lubricant with a soft cloth and a mild, non-abrasive cleaner.

Assembly requires the included hex keys  and your own Phillips screwdriver , adjustable wrench , scissors , and rubber mallet .

Use the drawings below to identify the assembly hardware. The number in parentheses below each drawing is the key number of the part, from the PART LIST near the end of this manual. The number after the parentheses is the quantity needed for assembly. **Note: If a part is not in the hardware kit, check to see if it is preattached to one of the parts to be assembled. To avoid damaging plastic parts, do not use power tools for assembly. Extra hardware may be included.**

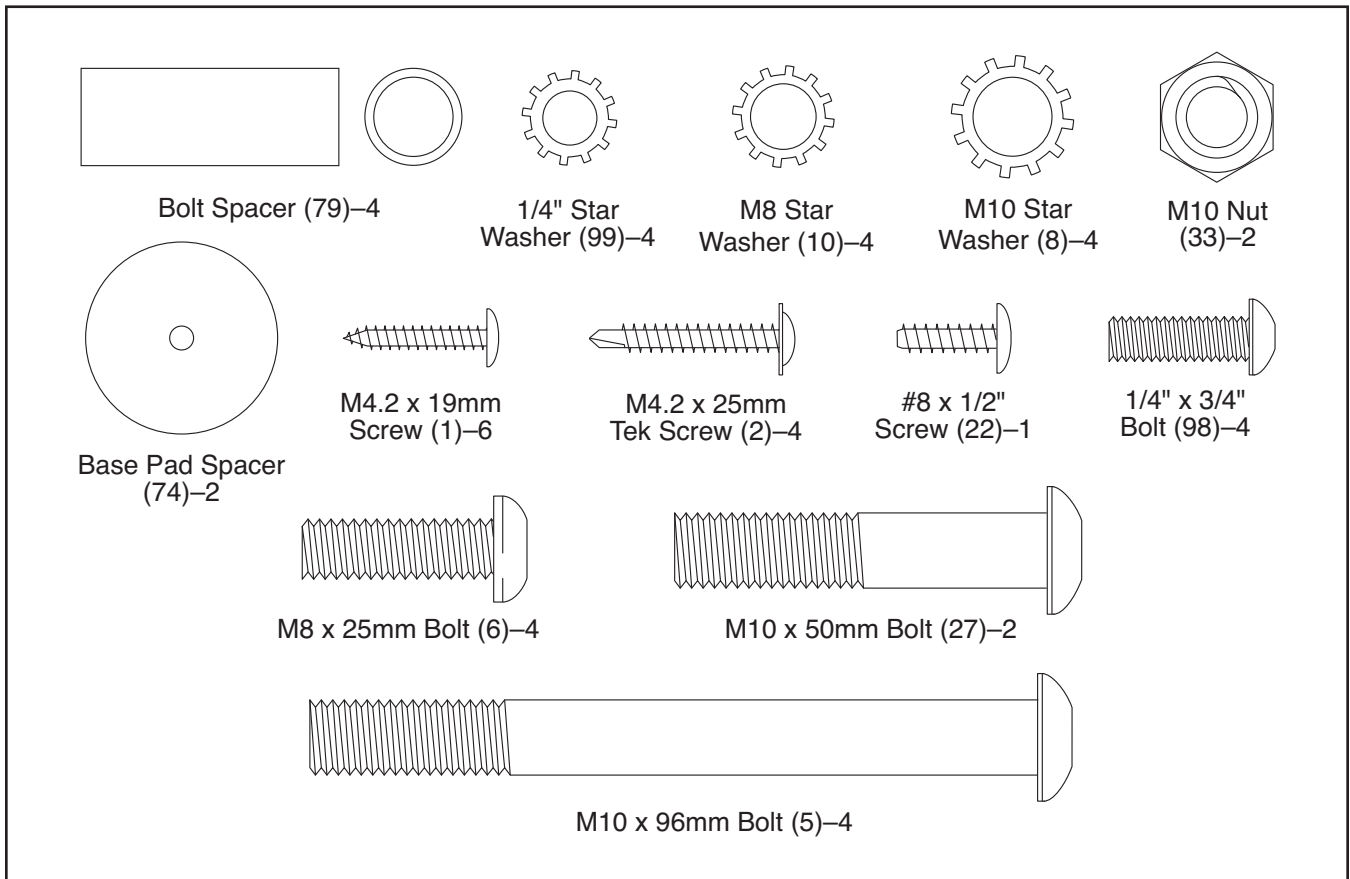

1. **Make sure that the power cord is unplugged.**

With the help of a second person, carefully tip the treadmill onto its left side. Partially fold the Frame (48) so that the treadmill is more stable; **do not fully fold the Frame yet.**

Cut the tie securing the Wire Harness (77) to the Base (85). Next, locate a tie in the indicated hole in the Base, and use the tie to pull the Wire Harness out of the hole.

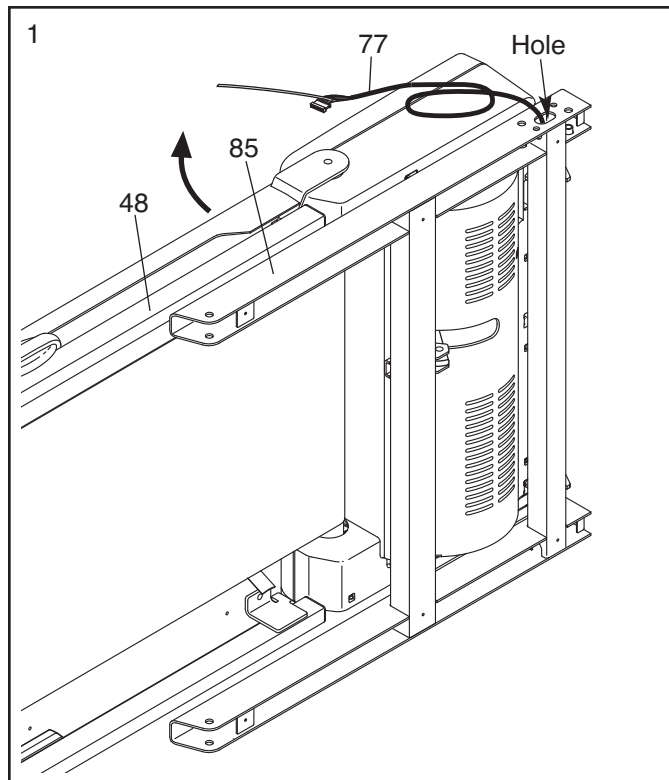

2. Attach two Base Pads (81) to the Base (85) in the locations shown with two M4.2 x 25mm Tek Screws (2) and two Base Pad Spacers (74).

Attach the other two Base Pads (81) with only two M4.2 x 25mm Tek Screws (2).

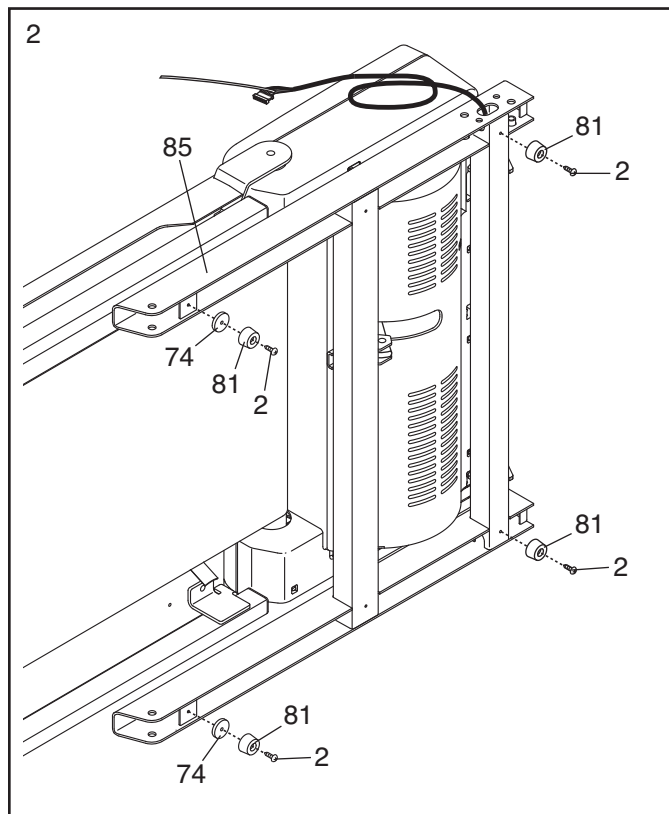

- Attach a Wheel (86) to the Base (85) with an M10 x 50mm Bolt (27) and an M10 Nut (33). **Do not overtighten the Nut; the Wheel must turn freely.**

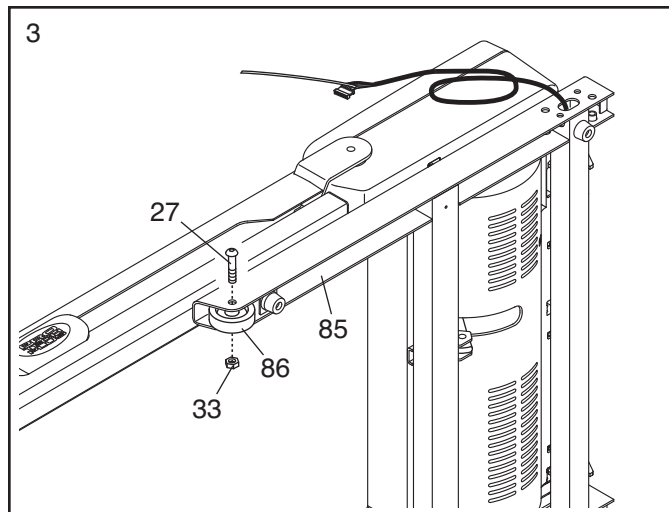

- Identify the Right Upright (78) and the Right Upright Spacer (80), which are marked with stickers.

Insert the Wire Harness (77) through the Right Upright Spacer (80) as shown. Then, set the Right Upright Spacer on the Base (85).

Have a second person hold the Right Upright (78) near the Base (85). **See the inset drawing.** Tie the wire tie in the Right Upright securely around the end of the Wire Harness (77). Then, pull the other end of the wire tie until the Wire Harness is routed completely through the Right Upright.

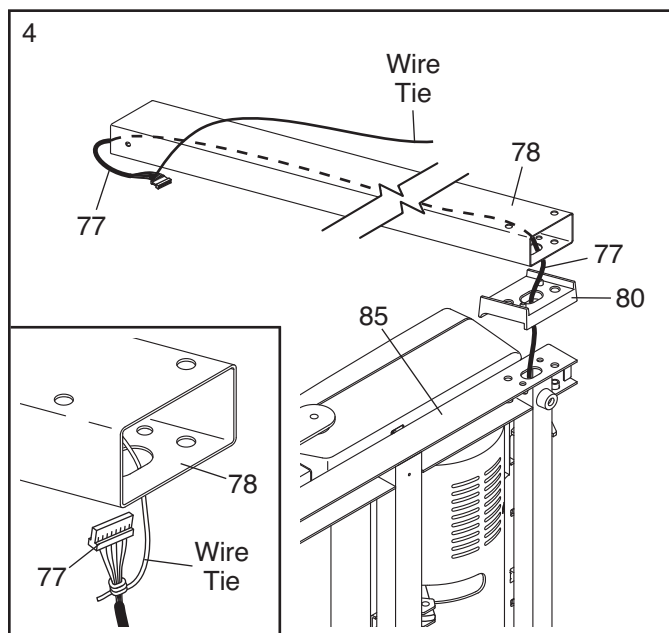

- Hold a Bolt Spacer (79) inside the lower end of the Right Upright (78). Insert an M10 x 96mm Bolt (5) with an M10 Star Washer (8) into the Right Upright and the Bolt Spacer. **Repeat this step with a second Bolt Spacer (79), M10 x 96mm Bolt (5), and M10 Star Washer (8).**

Hold the Right Upright (78) against the Right Upright Spacer (80). **Be careful not to pinch the Wire Harness (77).** Tighten the M10 x 96mm Bolts (5) until the heads of the Bolts touch the Upright; **do not fully tighten the Bolts yet.**

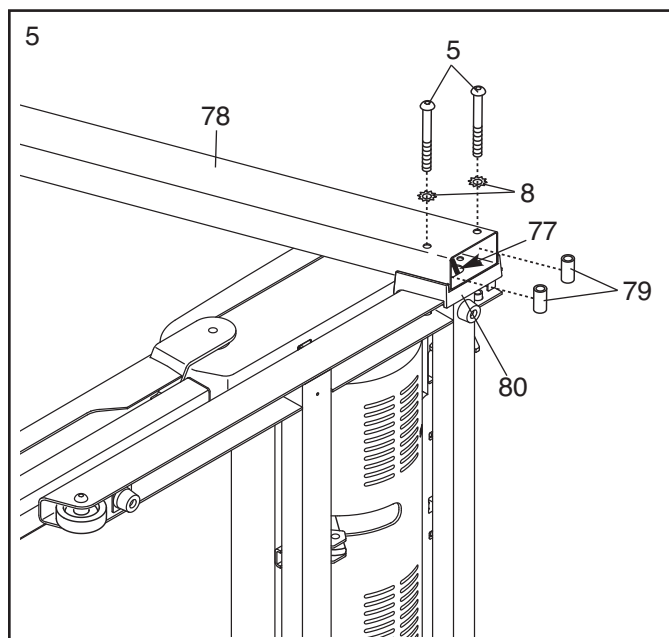

6. Press a Base Cap (82) into the Base (85).

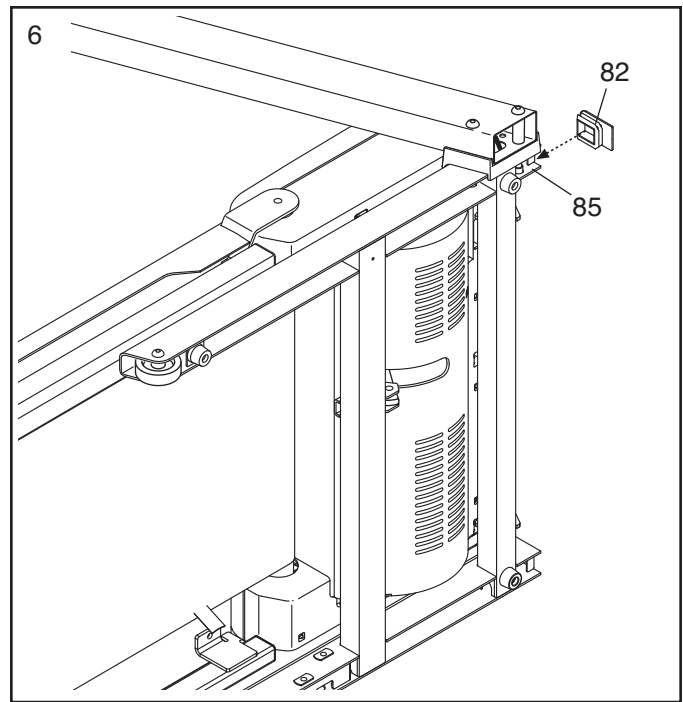

7. With the help of a second person, carefully tip the treadmill onto its right side. Partially fold the Frame (48) so that the treadmill is more stable; **do not fully fold the Frame yet.**

Attach a Wheel (86) to the Base (85) with an M10 x 50mm Bolt (27) and an M10 Nut (33). **Do not overtighten the Nut; the Wheel must turn freely.**

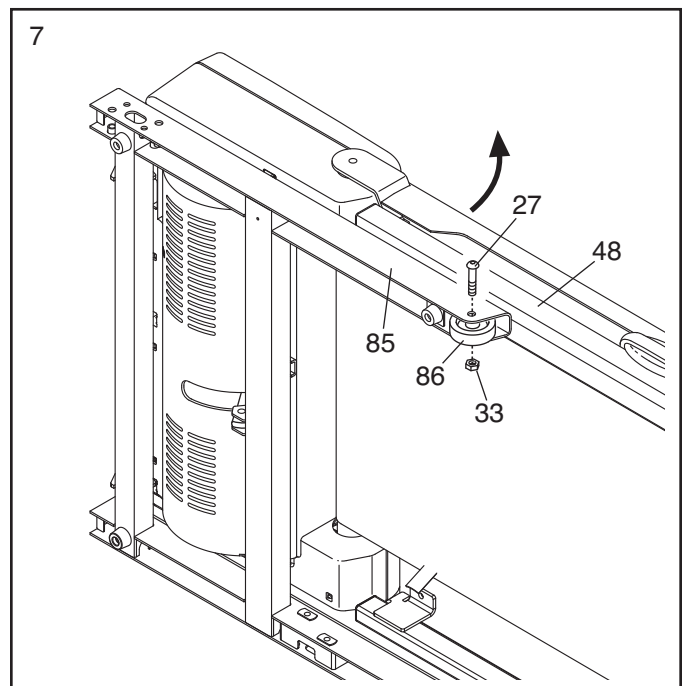

8. Hold a Bolt Spacer (79) inside the lower end of the Left Upright (73). Insert an M10 x 96mm Bolt (5) with an M10 Star Washer (8) into the Left Upright and the Bolt Spacer. **Repeat this step with a second Bolt Spacer (79), M10 x 96mm Bolt (5), and M10 Star Washer (8).**

Orient the Left Upright Spacer (83) and the Left Upright (73) as shown. Hold the Left Upright Spacer and the Left Upright against the Base (85). Tighten the M10 x 96mm Bolts (5) until the heads of the Bolts touch the Upright; **do not fully tighten the Bolts yet.**

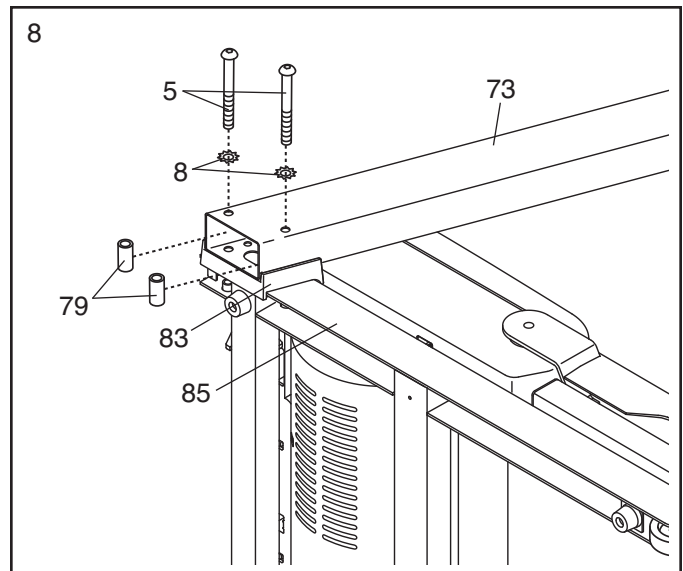

9. Press a Base Cap (82) into the Base (85).

With the help of a second person, tip the treadmill so that the Base (85) is flat on the floor.

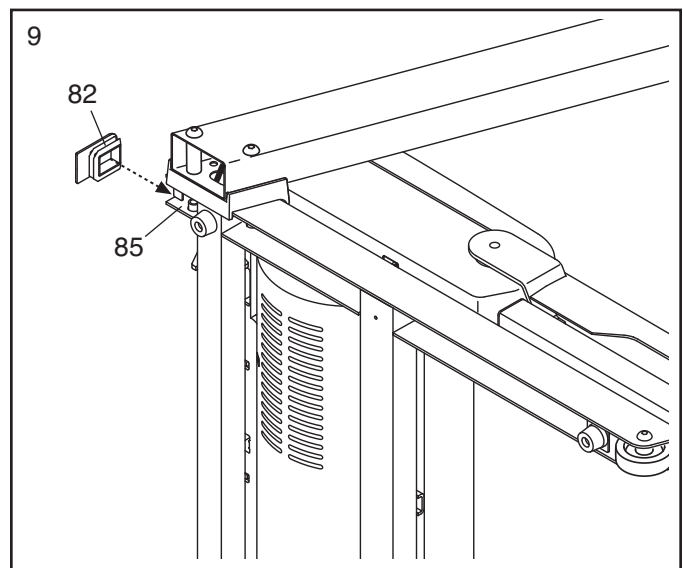

10. Attach the Dumbbell Rack (100) to the Uprights (73, 78) with four 1/4" x 3/4" Bolts (98) and four 1/4" Star Washers (99); **do not fully tighten the Bolts yet.**

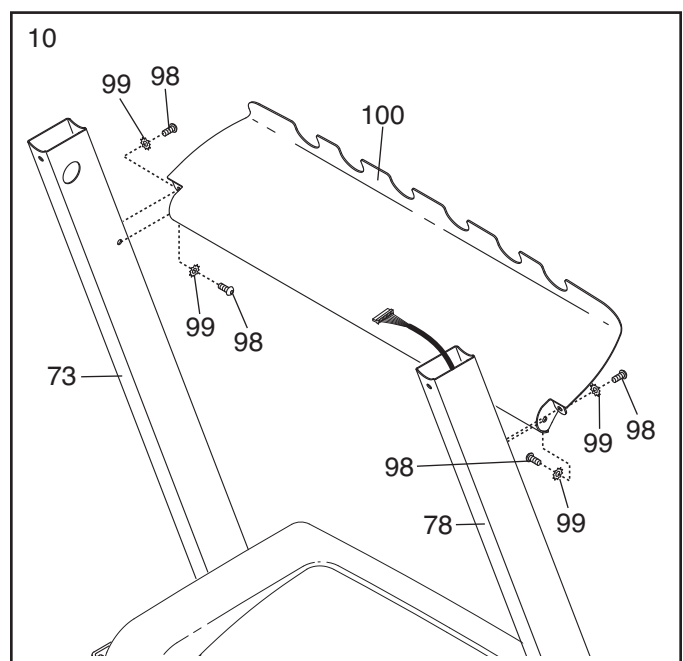

11. Set the Console (87) face down on a soft surface to avoid scratching the Console. Identify the Right Handrail (90), which has a large hole in the location shown. Hold the Right Handrail near the Console. Attach the console ground wire to the Right Handrail with a #8 x 1/2" Screw (22).

Next, insert the console wire into the large hole in the Right Handrail (90) and out of the top as shown. Attach the Right Handrail with three M4.2 x 19mm Screws (1). **Make sure that no wires are pinched. Start all three Screws before tightening any of them; do not over-tighten the Screws.**

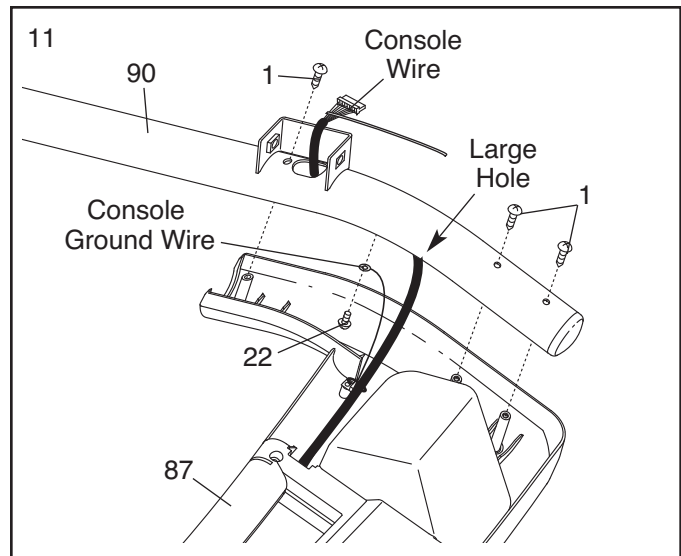

12. Attach the Left Handrail (89) to the console assembly with three M4.2 x 19mm Screws (1). **Start all three Screws before tightening any of them; do not overtighten the Screws.**

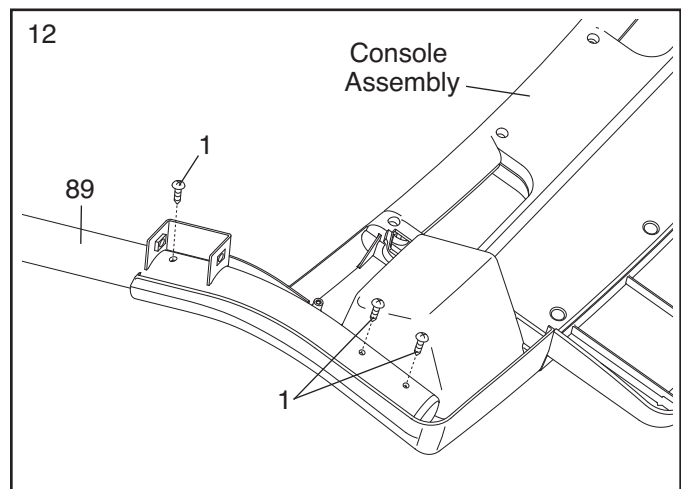

13. Have a second person hold the console assembly near the Right Upright (78). Cut the ties on the Right Handrail (90) and the Left Handrail (not shown). If necessary, press the four Cage Nuts (38) back into place.

Connect the Wire Harness (77) to the console wire. **See the inset drawing. The connectors should slide together easily and snap into place.** If they do not, turn one connector and try again. **IF THE CONNECTORS ARE NOT CONNECTED PROPERLY, THE CONSOLE MAY BE DAMAGED WHEN THE POWER IS TURNED ON.** Remove the wire ties from the Wire Harness and the console wire. Then, insert the connectors into the Right Upright (78).

Set the console assembly on the Right Upright (78) and the Left Upright (not shown). **Make sure that no wires are pinched.**

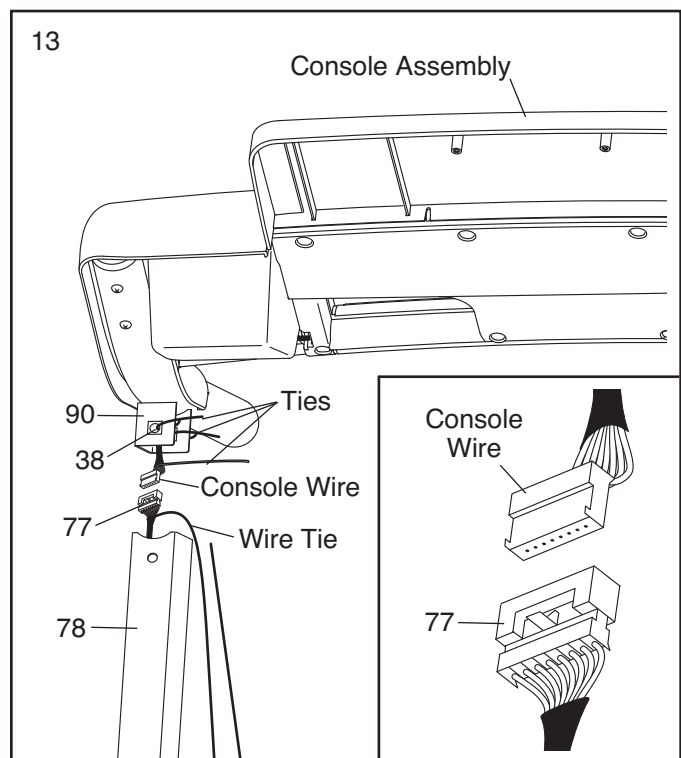

14. Partially tighten four M8 x 25mm Bolts (6) with four M8 Star Washers (10) into the Uprights (73, 78) and the Handrails (89, 90). **Then, tighten all four Handrail Bolts.**

See steps 5, 8, and 10. Tighten the four M10 x 96mm Bolts (5) and the four 1/4" x 3/4" Bolts (98).

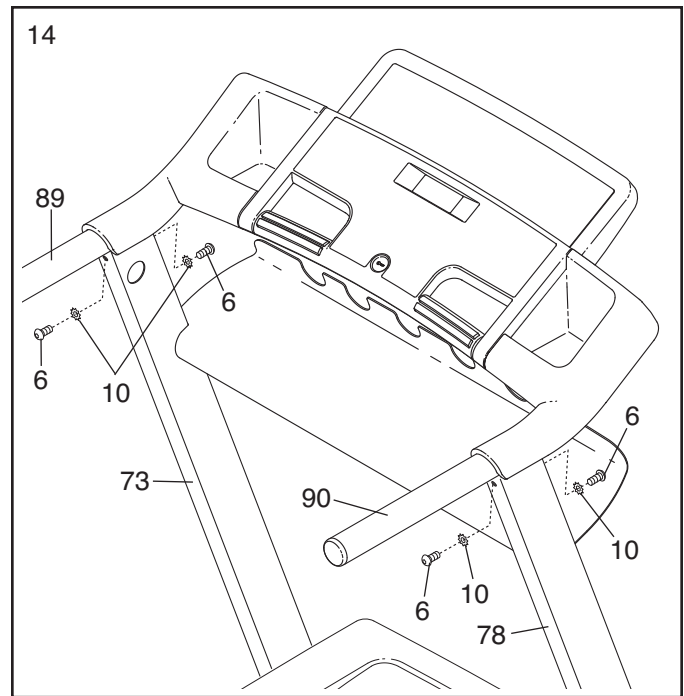

15. Press the Latch Insert (70) into the Left Upright (73). If necessary, tap on the Latch Insert with a rubber mallet.

Locate the Latch Pin Assembly (72). Remove the knob from the pin. Make sure that the collar and the spring are on the pin. Next, insert the pin into the Latch Insert (70), and tighten the knob back onto the pin.

Set the Dumbbells (not shown) in the Dumbbell Rack (100), with the heaviest dumbbells in the center of the Dumbbell Rack.

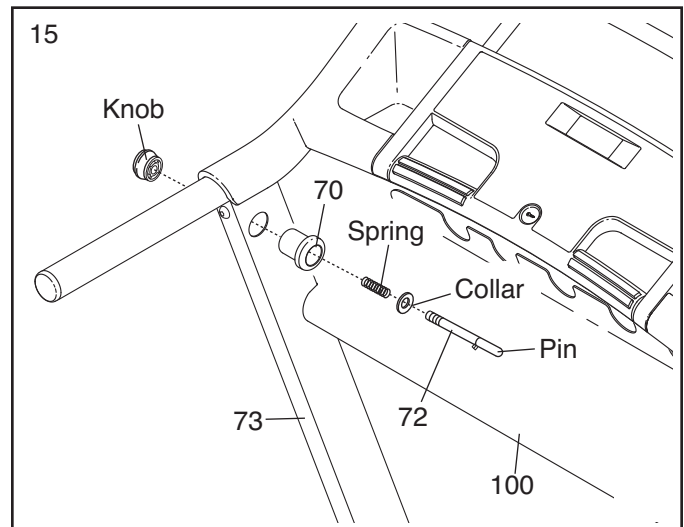

16. **Make sure that all parts are properly tightened before you use the treadmill.** If there are sheets of clear plastic on the treadmill decals, remove the plastic. To protect the floor or carpet, place a mat under the treadmill. Keep the included hex keys in a secure place; the large hex key is used to adjust the walking belt (see pages 22 and 23).

OPERATION AND ADJUSTMENT

THE PRE-LUBRICATED WALKING BELT

Your treadmill features a walking belt coated with high-performance lubricant. **IMPORTANT: Never apply silicone spray or other substances to the walking belt or the walking platform. Such substances will deteriorate the walking belt and cause excessive wear.**

HOW TO PLUG IN THE POWER CORD

⚠ DANGER: Improper connection of the equipment-grounding conductor can result in an increased risk of electric shock. Check with a qualified electrician or serviceman if you are in doubt as to whether the product is properly grounded. Do not modify the plug provided with the product—if it will not fit the outlet, have a proper outlet installed by a qualified electrician.

Your treadmill, like any other type of sophisticated electronic equipment, can be seriously damaged by sudden voltage changes in your home's power. Voltage surges, spikes, and noise interference can result from weather conditions or from other appliances being turned on or off. **To decrease the possibility of your treadmill being damaged, always use a surge suppressor with your treadmill (see drawing 1 at the right).** To purchase a surge suppressor, please see the front cover of this manual, or see your local electronics store.

Use only a single-outlet surge suppressor that is UL 1449 listed as a transient voltage surge suppressor (TVSS). The surge suppressor must have a UL suppressed voltage rating of 400 volts or less and a minimum surge dissipation of 450 joules. The surge suppressor must be electrically rated for 120 volts AC and 15 amps. There must be a monitoring light on the surge suppressor to indicate whether it is functioning properly. Failure to use a properly functioning surge suppressor could result in damage to the control system of the treadmill. If the control system is damaged, the walking belt may slow, accelerate, or stop unexpectedly, which may result in a fall and serious injury.

This product must be grounded. If it should malfunction or break down, grounding provides a path of least resistance for electric current to reduce the risk of electric shock. This product is equipped with a cord having

an equipment-grounding conductor and a grounding plug. **Plug the power cord into a surge suppressor, and plug the surge suppressor into an appropriate outlet that is properly installed and grounded in accordance with all local codes and ordinances. IMPORTANT: The treadmill is not compatible with GFCI-equipped outlets.**

This product is for use on a nominal 120-volt circuit, and has a grounding plug that looks like the plug illustrated in drawing 1 below. A temporary adapter that looks like the adapter illustrated in drawing 2 may be used to connect the surge suppressor to a 2-pole receptacle as shown in drawing 2 if a properly grounded outlet is not available.

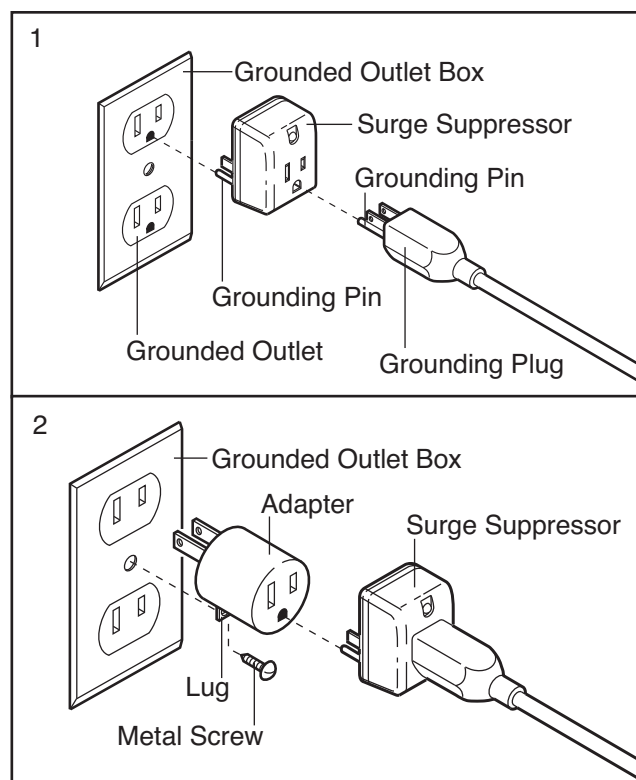

The temporary adapter should be used only until a properly grounded outlet (drawing 1) can be installed by a qualified electrician.

The green-colored rigid ear, lug, or the like extending from the adapter must be connected to a permanent ground such as a properly grounded outlet box cover. Whenever the adapter is used it must be held in place by a metal screw. **Some 2-pole receptacle outlet box covers are not grounded. Contact a qualified electrician to determine if the outlet box cover is grounded before using an adapter.**

CONSOLE DIAGRAM

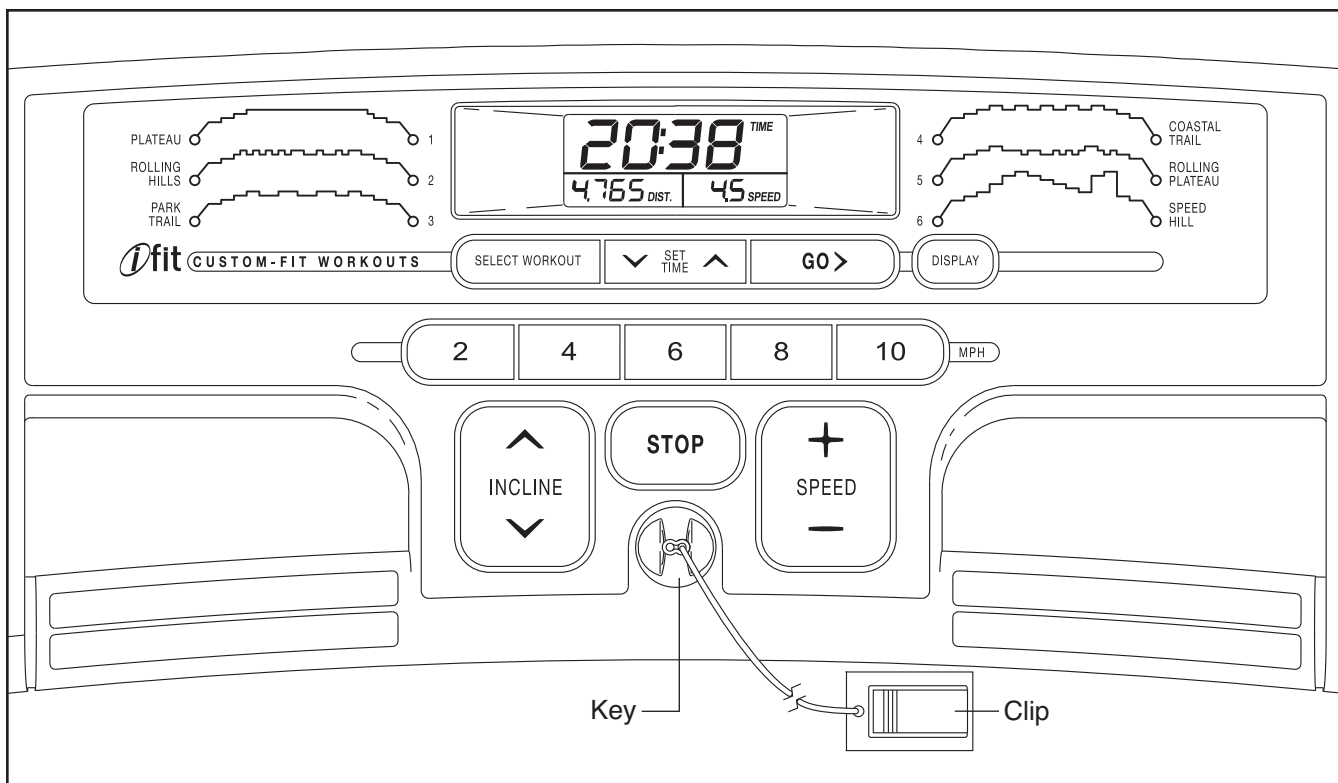

FEATURES OF THE CONSOLE

The treadmill console offers an impressive array of features designed to make your workouts more effective and enjoyable.

When you use the manual mode, you can change the speed and incline of the treadmill with the touch of a button. As you exercise, the console will display instant exercise feedback. You can even measure your heart rate using the handgrip pulse sensor.

In addition, the console offers six iFit custom-fit preset workouts. Each workout automatically controls the speed and incline of the treadmill as it guides you through an effective exercise session.

To turn on the power, see page 15. **To use the manual mode,** see page 15. **To use a preset workout,**

see page 17. **To use the information mode,** see page 18.

IMPORTANT: If there is a sheet of clear plastic on the console, remove the plastic. To prevent damage to the walking platform, wear clean athletic shoes while using the treadmill. The first time you use the treadmill, observe the alignment of the walking belt, and center the walking belt if necessary (see page 23).

Note: The console can display speed and distance in either miles or kilometers. To find out which unit of measurement is selected or to change the unit of measurement, see THE INFORMATION MODE on page 18. Note: For simplicity, all instructions in this section refer to miles.

HOW TO TURN ON THE POWER

IMPORTANT: If the treadmill has been exposed to cold temperatures, allow it to warm to room temperature before turning on the power. If you do not do this, you may damage the console displays or other electrical components.

Plug in the power cord (see page 13). Next, locate the reset/off circuit breaker on the treadmill frame near the power cord. Switch the circuit breaker to the reset position.

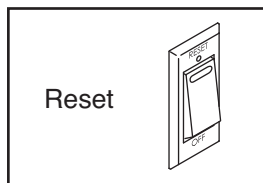

IMPORTANT: The console features a display demo mode, designed to be used if the treadmill is displayed in a store. If the displays light as soon as you plug in the power cord and switch the reset/off circuit breaker to the reset position, the demo mode is turned on. To turn off the demo mode, hold down the Stop button for a few seconds. If the displays remain lit, see THE INFORMATION MODE on page 18 to turn off the demo mode.

Next, stand on the foot rails of the treadmill. Find the clip attached to the key (see the drawing on page 14) and slide the clip onto the waistband of your clothes. Then, insert the key into the console. After a moment, the displays will light. **IMPORTANT:** In an emergency situation, the key can be pulled from the console, causing the walking belt to slow to a stop. Test the clip by carefully taking a few steps backward; if the key is not pulled from the console, adjust the position of the clip.

HOW TO USE THE MANUAL MODE

1. Insert the key into the console.

See HOW TO TURN ON THE POWER at the left.

2. Select the manual mode.

When the key is inserted, the manual mode will be selected. If a preset workout has been selected, remove the key and then reinsert it.

3. Start the walking belt.

To start the walking belt, press the Go button, the Speed increase button, or one of the speed buttons numbered 2 through 10.

If you press the Go button or the Speed increase button, the walking belt will begin to move at 1 mph. As you exercise, change the speed of the walking belt as desired by pressing the Speed increase and decrease buttons. Each time you press a button, the speed setting will change by 0.1 mph; if you hold down a button, the speed setting will change in increments of 0.5 mph. Note: After you press a button, it may take a moment for the walking belt to reach the selected speed setting.

If you press one of the numbered speed buttons, the walking belt will gradually change speed until it reaches the selected speed setting.

To stop the walking belt, press the Stop button. The time will begin to flash in the display. To restart the walking belt, press the Go button or the Speed increase button.

4. Change the incline of the treadmill as desired.

To change the incline of the treadmill, press the Incline increase or decrease button. Each time you press the Incline increase or decrease button, the incline will change by 0.5%. Note: After you press a button, it may take a moment for the treadmill to reach the selected incline setting.



5. Follow your progress with the displays.

The lower left display—

As you exercise, the lower left display can show the elapsed time and the distance that you have walked or run. The lower left display will also show the incline of the treadmill each time the incline level changes. Note: When a workout is selected, the display will show the time remaining in the workout instead of the elapsed time.



The lower right display—

The lower right display can show the approximate number of calories that you have burned and the speed of the walking belt. The display also shows your heart rate when you use the handgrip pulse sensor (see step 6).



The upper display—

The upper display can show the elapsed time, the distance that you have walked or run, the approximate number of calories that you have burned, or the speed of the walking belt. Press the Display button repeatedly until the upper display shows the information that you are most interested in viewing. Note: While information is shown in the upper display, the same information will not be shown in the lower displays.

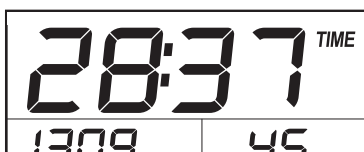

To reset the displays, press the Stop button, remove the key, and then reinsert the key.

6. Measure your heart rate if desired.

Before using the handgrip pulse sensor, remove the sheets of clear plastic from the metal contacts on the pulse bar. In addition, make sure that your hands are clean.

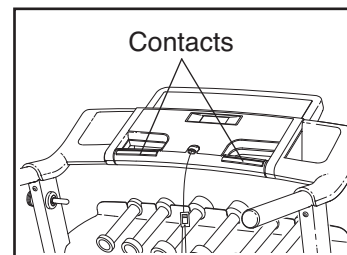

To measure your heart rate, **stand on the foot rails** and hold the metal contacts on the handrail. **Avoid moving your hands.** When your pulse is detected, a heart symbol in the lower right display will flash each time your heart beats, one or two dashes will appear, and then your heart rate will be shown. **For the most accurate heart rate reading, continue to hold the contacts for about 15 seconds.**

7. When you are finished exercising, remove the key from the console.

Step onto the foot rails, press the Stop button, and **adjust the incline of the treadmill to the lowest setting. The incline must be at the lowest setting or you may damage the treadmill when you fold it to the storage position.** Next, remove the key from the console and put it in a secure place.

When you are finished using the treadmill, switch the reset/off circuit breaker to the "off" position and unplug the power cord. **IMPORTANT: If you do not do this, the treadmill's electrical components may wear prematurely.**

HOW TO USE A PRESET WORKOUT

1. Insert the key into the console.

See HOW TO TURN ON THE POWER on page 15.

2. Select a preset workout.

To select a preset workout, press the Select Workout button repeatedly until the number of the desired workout appears in the upper display. Note: The name, number, and profile of each workout is listed on the console.

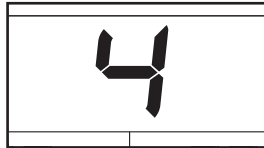

When you select a preset workout, the incline level of the workout will flash in the lower left display, the speed setting will flash in the upper display, and then the workout duration will appear in the lower left display.

3. Select the duration of the workout if desired.

You can set the duration of the workout to a time between 15 and 45 minutes, in increments of 5 minutes. To set the duration of the workout press the Set Time increase or decrease button until the desired time is selected. The new workout settings will appear in the displays.

4. Press the Go button or the Speed increase button to start the workout.

A moment after you press the button, the treadmill will automatically adjust to the first speed and incline settings of the workout. Hold the handrails and begin walking.

Each workout is divided into 30 one-minute segments, unless you have changed the duration of the workout (see step 3). One speed setting and one incline setting are programmed for each seg-

ment. Note: The same speed setting and/or incline setting may be programmed for consecutive segments.

Tones will sound at the end of each segment. Three seconds before the speed and/or incline of the treadmill is about to change, the speed and/or incline will flash in the display and a series of tones will sound to alert you. The treadmill will then automatically adjust to the speed and/or incline settings for the next segment.

The workout will continue in this way until the last segment ends. The walking belt will then slow to a stop.

If the speed or incline setting is too high or too low at any time during the workout, you can manually override the setting by pressing the speed or incline buttons; **however, when the next segment of the workout begins, the treadmill will automatically adjust to the speed and incline settings for the next segment.**

To stop the workout at any time, press the Stop button. To restart the workout, press the Go button. The walking belt will begin to move at 1 mph. When the next segment of the workout begins, the treadmill will automatically adjust to the speed and incline settings for the next segment.

5. Follow your progress with the displays.

See step 5 on page 16.

6. Measure your heart rate if desired.

See step 6 on page 16.

7. When you are finished exercising, remove the key from the console.

See step 7 on page 16.

THE INFORMATION MODE

The console features an information mode that keeps track of the total distance that the walking belt has moved and the total number of hours that the treadmill has been used. The information mode also allows you to select a unit of measurement and to turn on and turn off the display demo mode.

To select the information mode, hold down the Stop button while inserting the key into the console and then release the Stop button. When the information mode is selected, the following information will be shown:

An "E" for English miles or an "M" for metric kilometers will appear in the lower right display. Press the Speed increase button to change the unit of measurement if desired.



The lower left display will show the total number of miles (or kilometers) that the walking belt has moved.



The upper display will show the total number of hours the treadmill has been used.

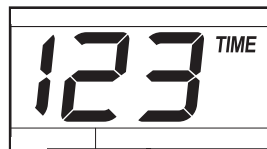

The console features a display demo mode, designed to be used if the treadmill is displayed in a store. While the demo mode is turned on, the console will function normally when you plug in the power cord, switch the reset/off circuit breaker to the reset position, and insert the key into the console. However, when you remove the key, the displays will remain lit, although the buttons will not function. If the demo mode is turned on, a "d" will appear in the lower right display while the information mode is selected. To turn on or off the demo mode, press the Speed decrease button.

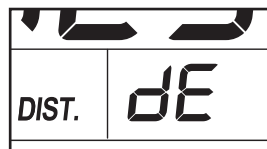

To exit the information mode, remove the key from the console.

HOW TO USE THE DUMBBELLS

To exercise your upper body as you walk on the treadmill, hold the 2-pound dumbbells at your sides or press the dumbbells above your head. To increase the intensity of your exercise, use the 3-pound or 5-pound dumbbells. The dumbbells can be stored in the dumbbell rack.

WARNING: Do not use the dumbbells at speeds faster than a walk. Using dumbbells and not holding the handrails may compromise your ability to maintain your balance. Exercises using dumbbells should be attempted only by experienced users.

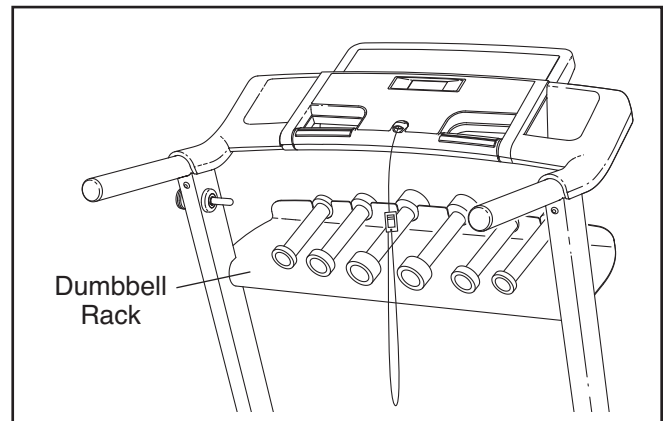

HOW TO FOLD AND MOVE THE TREADMILL

HOW TO FOLD THE TREADMILL FOR STORAGE

Before folding the treadmill, adjust the incline to the lowest position. If you do not do this, you may damage the treadmill when you fold it. Remove the key and unplug the power cord. **CAUTION:** You must be able to safely lift 45 lbs. (20 kg) to raise, lower, or move the treadmill.

1. Hold the metal frame firmly in the location shown by the arrow at the right. **CAUTION:** To decrease the possibility of injury, do not lift the frame by the plastic foot rails. Make sure to bend your legs and keep your back straight as you raise the frame. Raise the frame about halfway to the vertical position.
2. Move your right hand to the position shown and hold the treadmill firmly. Using your left hand, pull the latch knob to the left and hold it. Raise the frame until the pin is aligned with the gap between the frame and platform, and then slowly release the latch knob. **Make sure that the latch pin is fully inserted into the gap.**

To protect the floor or carpet from damage, place a mat under the treadmill. Keep the treadmill out of direct sunlight. Do not leave the treadmill in the storage position in temperatures above 85° F (30° C).

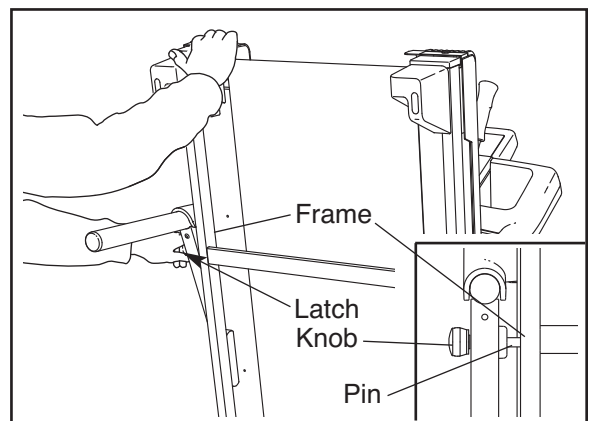
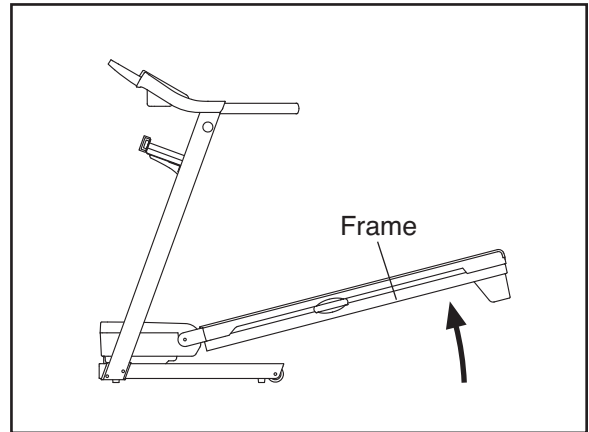

HOW TO MOVE THE TREADMILL

Before moving the treadmill, convert it to the storage position as described above. **Make sure that the latch pin is fully inserted into the gap.** Remove the dumbbells from the dumbbell rack.

1. Hold a handrail and the frame, and place one foot against one of the wheels.
2. Tilt the treadmill back until it rolls freely on the wheels. Do not pull back on the frame. Carefully move the treadmill to the desired location. **Never move the treadmill without tipping it back. To reduce the risk of injury, use extreme caution while moving the treadmill. Do not attempt to move the treadmill over an uneven surface.**
3. Place one foot against a wheel, and carefully lower the treadmill until it is resting in the storage position. Place the dumbbells back on the dumbbell rack with the heaviest dumbbell in the center of the rack.

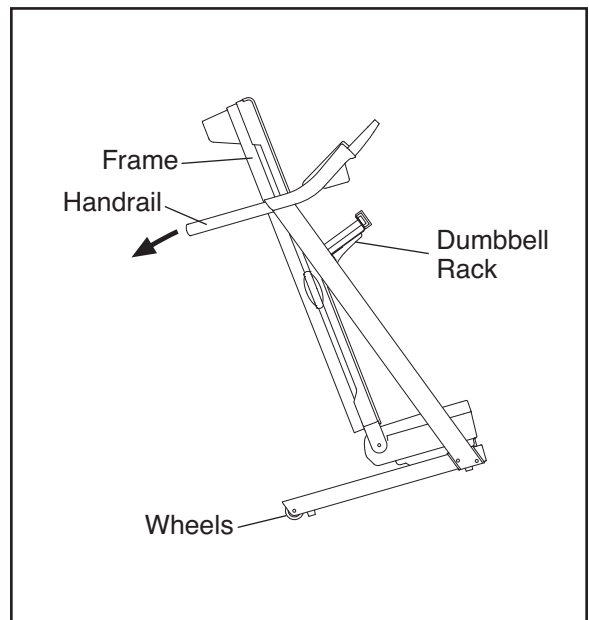

HOW TO LOWER THE TREADMILL FOR USE

1. Hold the upper end of the treadmill with your right hand. Pull the latch knob to the left and hold it. Pivot the frame down until it is past the latch pin. Then, release the latch knob.

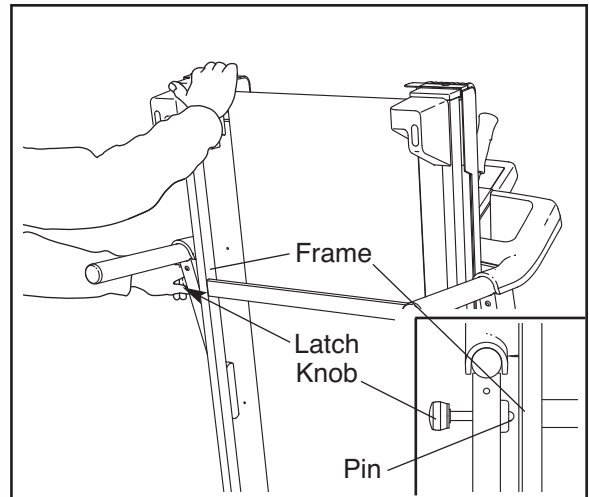

2. Hold the metal frame firmly with both hands and lower it to the floor. **CAUTION: Do not grip only the plastic foot rails or drop the frame to the floor. Bend your legs and keep your back straight.**

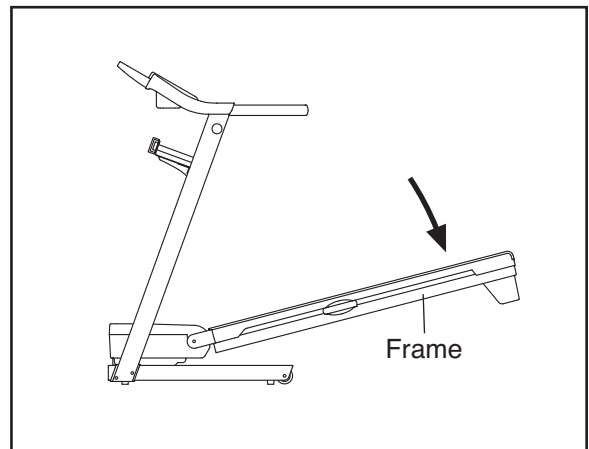

TROUBLESHOOTING

Most treadmill problems can be solved by following the steps below. Find the symptom that applies, and follow the steps listed. If further assistance is needed, please see the front cover of this manual.

PROBLEM: The power does not turn on

SOLUTION: a. Make sure that the power cord is plugged into a surge suppressor, and that the surge suppressor is plugged into a properly grounded outlet (see page 13). Use only a single-outlet surge suppressor that meets all of the specifications described on page 13. **IMPORTANT: The treadmill is not compatible with GFCI-equipped outlets.**

b. After the power cord has been plugged in, make sure that the key is inserted into the console.

c. Check the reset/off circuit breaker located on the treadmill frame near the power cord. If the switch protrudes as shown, the circuit breaker has tripped. To reset the circuit breaker, wait for five minutes and then press the switch back in.

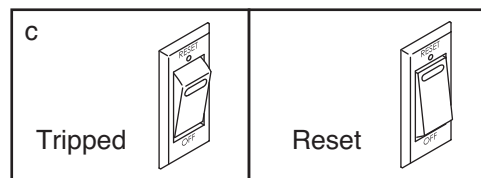

PROBLEM: The power turns off during use

SOLUTION: a. Check the reset/off circuit breaker (see the drawing above). If the circuit breaker has tripped, wait for five minutes and then press the switch back in.

b. Make sure that the power cord is plugged in. If the power cord is plugged in, unplug it, wait for five minutes, and then plug it back in.

c. Remove the key from the console. Reinsert the key into the console.

d. If the treadmill still will not run, please see the front cover of this manual.

PROBLEM: The console displays remain lit when you remove the key from the console

SOLUTION: a. The console features a display demo mode, designed to be used if the treadmill is displayed in a store. If the displays remain lit when you remove the key, the demo mode is turned on. To turn off the demo mode, hold down the Stop button for a few seconds. If the displays are still lit, see THE INFORMATION MODE on page 18 to turn off the demo mode.

PROBLEM: The displays of the console do not function properly

SOLUTION: a. Adjust the incline level of the treadmill to 5 percent. Remove the dumbbells from the dumbbell rack.

Remove the key from the console and **UNPLUG THE POWER CORD**. With the help of a second person, carefully tip down the Uprights (73, 78). There may be two M4.2 x 19mm Pan Head Screws (12) in the bottom of the Belly Pan (69). If there are, remove them. Note: A Phillips screwdriver with a shaft at least 5 in. (13 cm) long is required. Then, raise the Uprights.

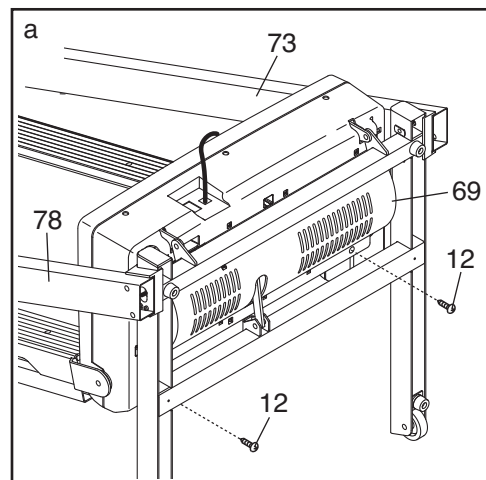

Remove the three M4.2 x 19mm Screws (13) and carefully pivot the Motor Hood (53) off.

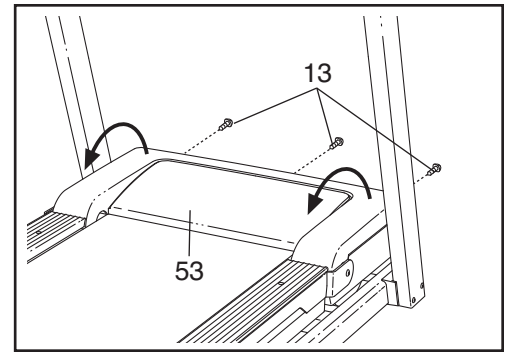

Locate the Reed Switch (54) and the Magnet (42) on the left side of the Pulley (44). Turn the Pulley until the Magnet is aligned with the Reed Switch. **Make sure that the gap between the Magnet and the Reed Switch is about 1/8 in. (3 mm).** If necessary, loosen the M4.2 x 19mm Screw (1), move the Reed Switch slightly, and then retighten the Screw. Reattach the Motor Hood (not shown) with the three M4.2 x 19mm Screws (not shown) and with the two M4.2 x 19mm Pan Head Screws (not shown) if necessary. Run the treadmill for a few minutes to check for a correct speed reading.

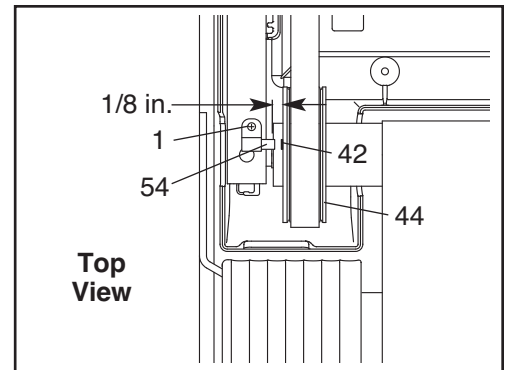

PROBLEM: The incline of the treadmill does not change correctly

SOLUTION: a. With the key in the console, press one of the Incline buttons. **While the incline is changing, remove the key.** After a few seconds, re-insert the key. The treadmill will automatically rise to the maximum incline level and then return to the minimum level. This will recalibrate the incline system.

PROBLEM: The walking belt slows when walked on

SOLUTION: a. Use only a single-outlet surge suppressor that meets all of the specifications described on page 13.

b. If the walking belt is overtightened, treadmill performance may decrease and the walking belt may become damaged. Remove the key and **UNPLUG THE POWER CORD.** Using the hex key, turn both idler roller bolts counterclockwise, 1/4 of a turn. When the walking belt is properly tightened, you should be able to lift each edge of the walking belt 2 to 3 in. (5 to 7 cm) off the walking platform. Be careful to keep the walking belt centered. Then, plug in the power cord, insert the key, and run the treadmill for a few minutes. Repeat until the walking belt is properly tightened.

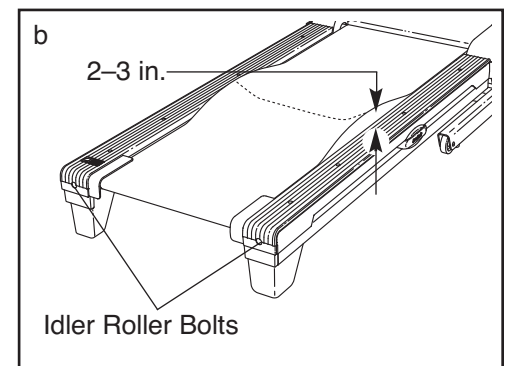

c. If the walking belt still slows when walked on, see the front cover of this manual.

PROBLEM: The walking belt is off-center or slips when walked on

SOLUTION: a. **If the walking belt is off-center**, first remove the key and **UNPLUG THE POWER CORD**. **If the walking belt has shifted to the left**, use the hex key to turn the left idler roller bolt clockwise 1/2 of a turn; **if the walking belt has shifted to the right**, turn the bolt counterclockwise 1/2 of a turn. Be careful not to overtighten the walking belt. Then, plug in the power cord, insert the key, and run the treadmill for a few minutes. Repeat until the walking belt is centered.

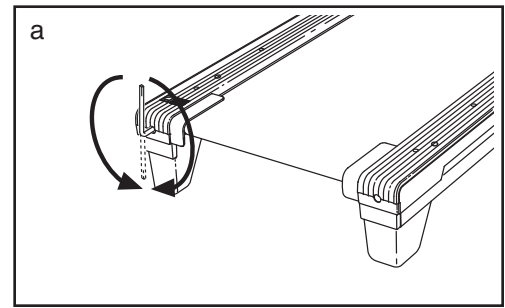

b. **If the walking belt slips when walked on**, first remove the key and **UNPLUG THE POWER CORD**. Using the hex key, turn both idler roller bolts clockwise, 1/4 of a turn. When the walking belt is correctly tightened, you should be able to lift each side of the walking belt 2 to 3 in. (5 to 7 cm) off the walking platform. Be careful to keep the walking belt centered. Then, plug in the power cord, insert the key, and carefully walk on the treadmill for a few minutes. Repeat until the walking belt is properly tightened.

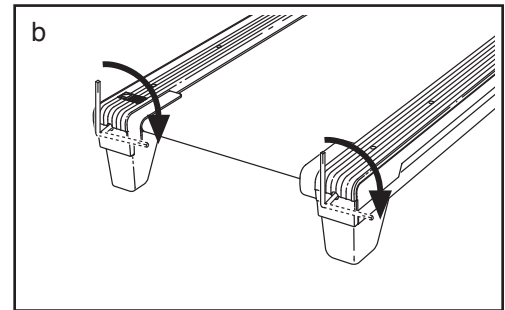

EXERCISE GUIDELINES

⚠️ WARNING: Before beginning this or any exercise program, consult your physician. This is especially important for individuals over the age of 35 or individuals with pre-existing health problems.

The pulse sensor is not a medical device. Various factors, including your movement, may affect the accuracy of heart rate readings. The sensor is intended only as an exercise aid in determining heart rate trends in general.

These guidelines will help you to plan your exercise program. For detailed exercise information, obtain a reputable book or consult your physician. Remember, proper nutrition and adequate rest are essential for successful results.

EXERCISE INTENSITY

Whether your goal is to burn fat or to strengthen your cardiovascular system, exercising at the proper intensity is the key to achieving results. You can use your heart rate as a guide to find the proper intensity level. The chart below shows recommended heart rates for fat burning and aerobic exercise.

165	155	145	140	130	125	115	♥
145	138	130	125	118	110	103	♥
125	120	115	110	105	95	90	♥
<hr/>							
20	30	40	50	60	70	80	

To find the proper intensity level, find your age at the bottom of the chart (ages are rounded off to the nearest ten years). The three numbers listed above your age define your “training zone.” The lowest number is the heart rate for fat burning, the middle number is the heart rate for maximum fat burning, and the highest number is the heart rate for aerobic exercise.

Burning Fat—To burn fat effectively, you must exercise at a low intensity level for a sustained period of time. During the first few minutes of exercise, your body uses *carbohydrate calories* for energy. Only after the first few minutes of exercise does your body begin to use stored *fat calories* for energy. If your goal is to burn fat, adjust the intensity of your exercise until your heart rate is near the lowest number in your training zone. For maximum fat burning, exercise with your heart rate near the middle number in your training zone.

Aerobic Exercise—If your goal is to strengthen your cardiovascular system, you must perform aerobic exercise, which is activity that requires large amounts of oxygen for prolonged periods of time. For aerobic exercise, adjust the intensity of your exercise until your heart rate is near the highest number in your training zone.

WORKOUT GUIDELINES

Warming Up—Start with 5 to 10 minutes of stretching and light exercise. A warm-up increases your body temperature, heart rate, and circulation in preparation for exercise.

Training Zone Exercise—Exercise for 20 to 30 minutes with your heart rate in your training zone. (During the first few weeks of your exercise program, do not keep your heart rate in your training zone for longer than 20 minutes.) Breathe regularly and deeply as you exercise—never hold your breath.

Cooling Down—Finish with 5 to 10 minutes of stretching. Stretching increases the flexibility of your muscles and helps to prevent post-exercise problems.

EXERCISE FREQUENCY

To maintain or improve your condition, complete three workouts each week, with at least one day of rest between workouts. After a few months of regular exercise, you may complete up to five workouts each week, if desired. Remember, the key to success is to make exercise a regular and enjoyable part of your everyday life.

SUGGESTED STRETCHES

The correct form for several basic stretches is shown at the right. Move slowly as you stretch—never bounce.

1. Toe Touch Stretch

Stand with your knees bent slightly and slowly bend forward from your hips. Allow your back and shoulders to relax as you reach down toward your toes as far as possible. Hold for 15 counts, then relax. Repeat 3 times. Stretches: Hamstrings, back of knees and back.

2. Hamstring Stretch

Sit with one leg extended. Bring the sole of the opposite foot toward you and rest it against the inner thigh of your extended leg. Reach toward your toes as far as possible. Hold for 15 counts, then relax. Repeat 3 times for each leg. Stretches: Hamstrings, lower back and groin.

3. Calf/Achilles Stretch

With one leg in front of the other, reach forward and place your hands against a wall. Keep your back leg straight and your back foot flat on the floor. Bend your front leg, lean forward and move your hips toward the wall. Hold for 15 counts, then relax. Repeat 3 times for each leg. To cause further stretching of the achilles tendons, bend your back leg as well. Stretches: Calves, achilles tendons and ankles.

4. Quadriceps Stretch

With one hand against a wall for balance, reach back and grasp one foot with your other hand. Bring your heel as close to your buttocks as possible. Hold for 15 counts, then relax. Repeat 3 times for each leg. Stretches: Quadriceps and hip muscles.

5. Inner Thigh Stretch

Sit with the soles of your feet together and your knees outward. Pull your feet toward your groin area as far as possible. Hold for 15 counts, then relax. Repeat 3 times. Stretches: Quadriceps and hip muscles.

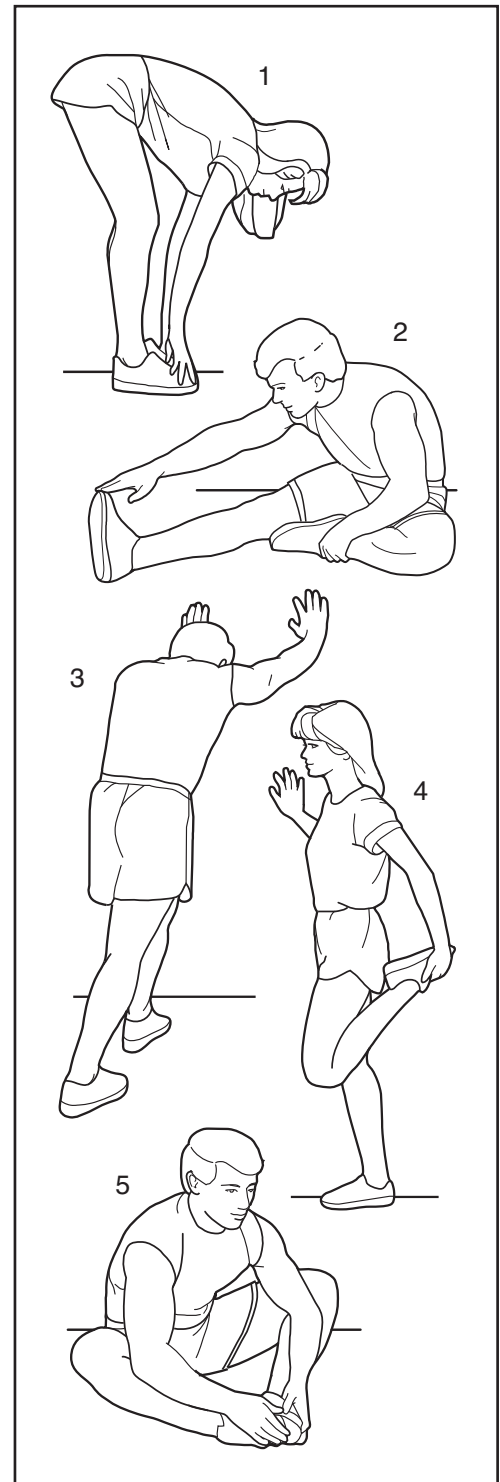

PART LIST—Model No. PMTL39708.0

R0509A

To locate the parts listed below, see the EXPLODED DRAWING near the end of this manual.

Key No.	Qty.	Description	Key No.	Qty.	Description
1	16	M4.2 x 19mm Screw	51	1	Left Foot
2	4	M4.2 x 25mm Tek Screw	52	1	Right Foot
3	1	Idler Roller	53	1	Motor Hood
4	1	Lift Motor Spacer	54	1	Reed Switch
5	4	M10 x 96mm Bolt	55	1	Reed Switch Clamp
6	4	M8 x 25mm Bolt	56	2	Frame Spacer
7	1	3/8" Star Washer	57	1	Lift Frame/Roller Ground Wire
8	4	M10 Star Washer	58	1	Incline Motor
9	1	M4.2 x 13mm Hypot Screw	59	2	Idler Roller Bracket
10	4	M8 Star Washer	60	1	Drive Motor
11	5	M4.2 x 13mm Screw	61	1	Motor Bracket
12	11	M4.2 x 16mm Screw	62	3	Lift Frame Cable Tie
13	3	M4.2 x 19mm Hood Screw	63	1	Lift Frame
14	2	M8 x 35mm Screw	64	1	5mm Hex Key
15	2	M8 x 90mm Screw	65	1	Power Cord
16	2	M10 x 30mm Bolt	66	1	Controller
17	2	M6 x 70mm Bolt	67	1	Grommet
18	1	3/8" x 1 3/4" Bolt	68	1	Reset/Off Circuit Breaker
19	1	3/8" x 1 1/2" Bolt	69	1	Belly Pan
20	2	3/8" x 1" Bolt	70	1	Latch Insert
21	1	M6 x 45mm Bolt	71	1	4mm Hex Key
22	7	#8 x 1/2" Screw	72	1	Latch Pin Assembly
23	8	M5.5 x 25mm Screw	73	1	Left Upright
24	2	1/4" x 3/8" Bolt	74	2	Base Pad Spacer
25	2	3/8" x 3/4" Bolt	75	2	Frame Cap
26	1	3/8" x 4" Bolt	76	1	Lift Frame/Base Ground Wire
27	2	M10 x 50mm Bolt	77	1	Wire Harness
28	4	M4.2 x 13mm Belt Guide Screw	78	1	Right Upright
29	2	M6 Split Washer	79	4	Bolt Spacer
30	2	M6 Washer	80	1	Right Upright Spacer
31	3	3/8" Jam Nut	81	4	Base Pad
32	2	3/8" Motor Nut	82	2	Base Cap
33	4	M10 Nut	83	1	Left Upright Spacer
34	1	6mm Hex Key	84	2	Caution Decal
35	4	M8 Flange Nut	85	1	Base
36	2	3/8" Locknut	86	2	Wheel
37	3	Hood Clip	87	1	Console
38	4	Cage Nut	88	1	Console Back
39	1	Left Foot Rail	89	1	Left Handrail
40	2	Platform Cushion	90	1	Right Handrail
41	2	Belt Guide	91	4	Handrail Cap
42	1	Magnet	92	2	Cable Tie
43	1	Motor Belt	93	1	Key/Clip
44	1	Drive Roller/Pulley	94	2	Releasable Tie
45	1	Walking Belt	95	8	8" Cable Tie
46	1	Walking Platform	96	1	Controller Ground Wire
47	1	Right Foot Rail	97	4	Nut Insert
48	1	Frame	98	4	1/4" x 3/4" Bolt
49	1	Warning Decal	99	4	1/4" Star Washer
50	2	Idler Roller Bracket Plate	100	1	Dumbbell Rack

Key No.	Qty.	Description	Key No.	Qty.	Description
101	2	2-lb. Dumbbell	108	2	Foot Rail Decal
102	2	3-lb. Dumbbell	*	—	8" Blue Wire, 2F
103	2	5-lb. Dumbbell	*	—	6" Blue Wire, M/F
104	2	M8 Locknut	*	—	6" Blue Wire, 2F
105	1	5/32" Hex Key	*	—	6" Red Wire, M/F
106	1	Incline Stop Plate	*	—	6" Black Wire, M/F
107	1	Filter Wire	*	—	User's Manual

Note: Specifications are subject to change without notice. See the front cover of this manual for information about ordering replacement parts. *These parts are not illustrated.

EXPLODED DRAWING A—Model No. PMTL39708.0

R0509A

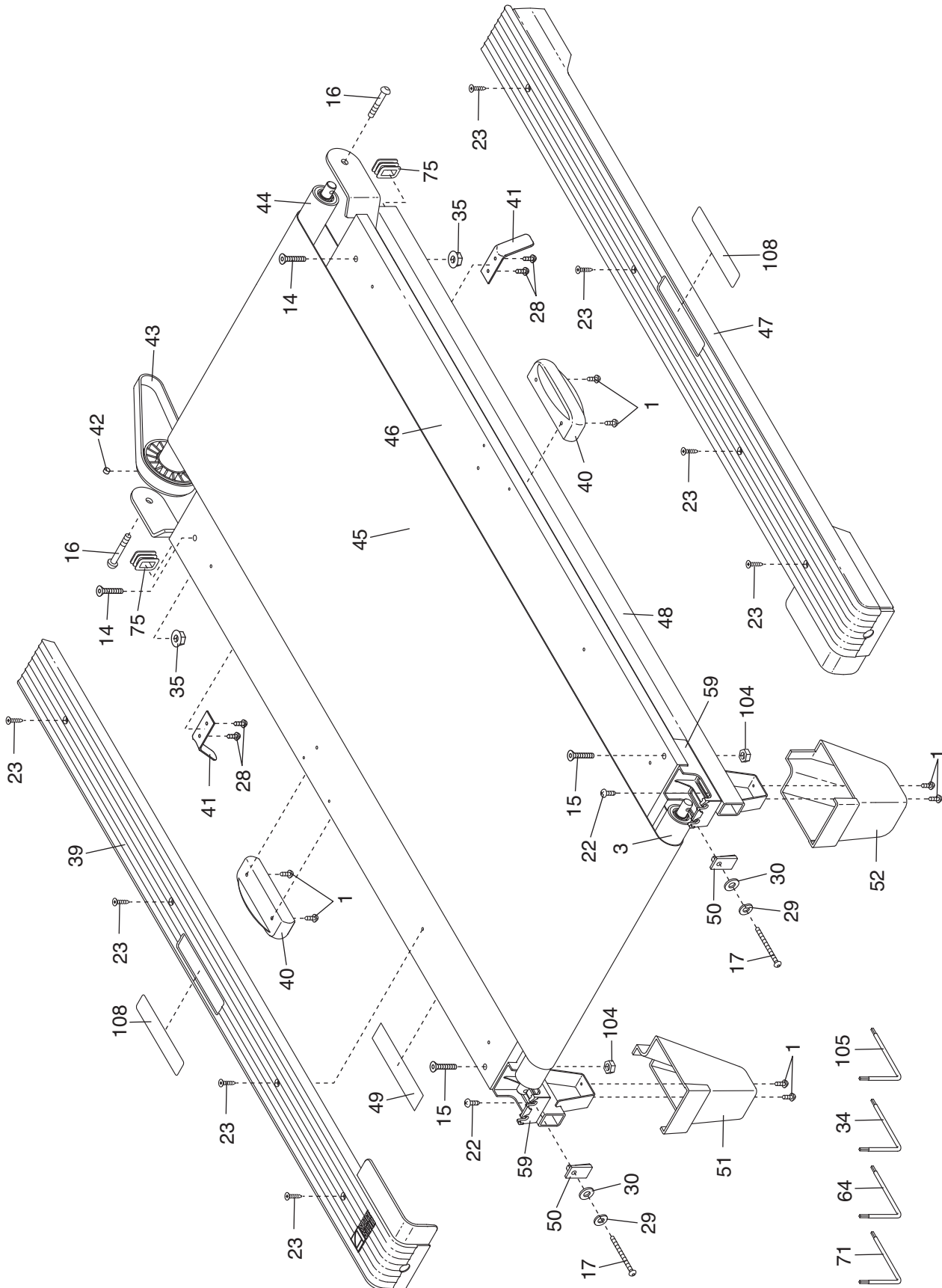

EXPLODED DRAWING B—Model No. PMTL39708.0

R0509A

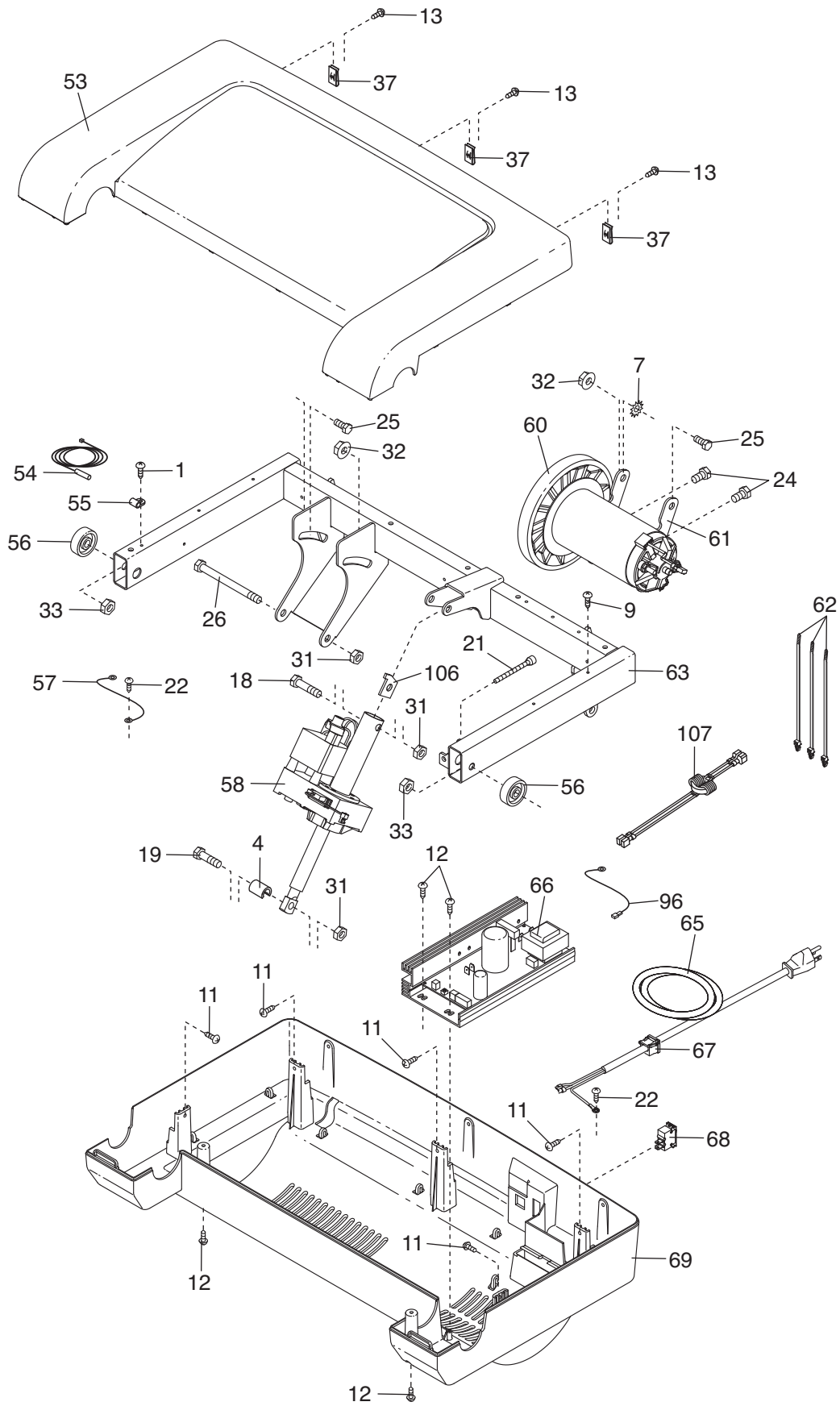

EXPLODED DRAWING C—Model No. PMTL39708.0

R0509A

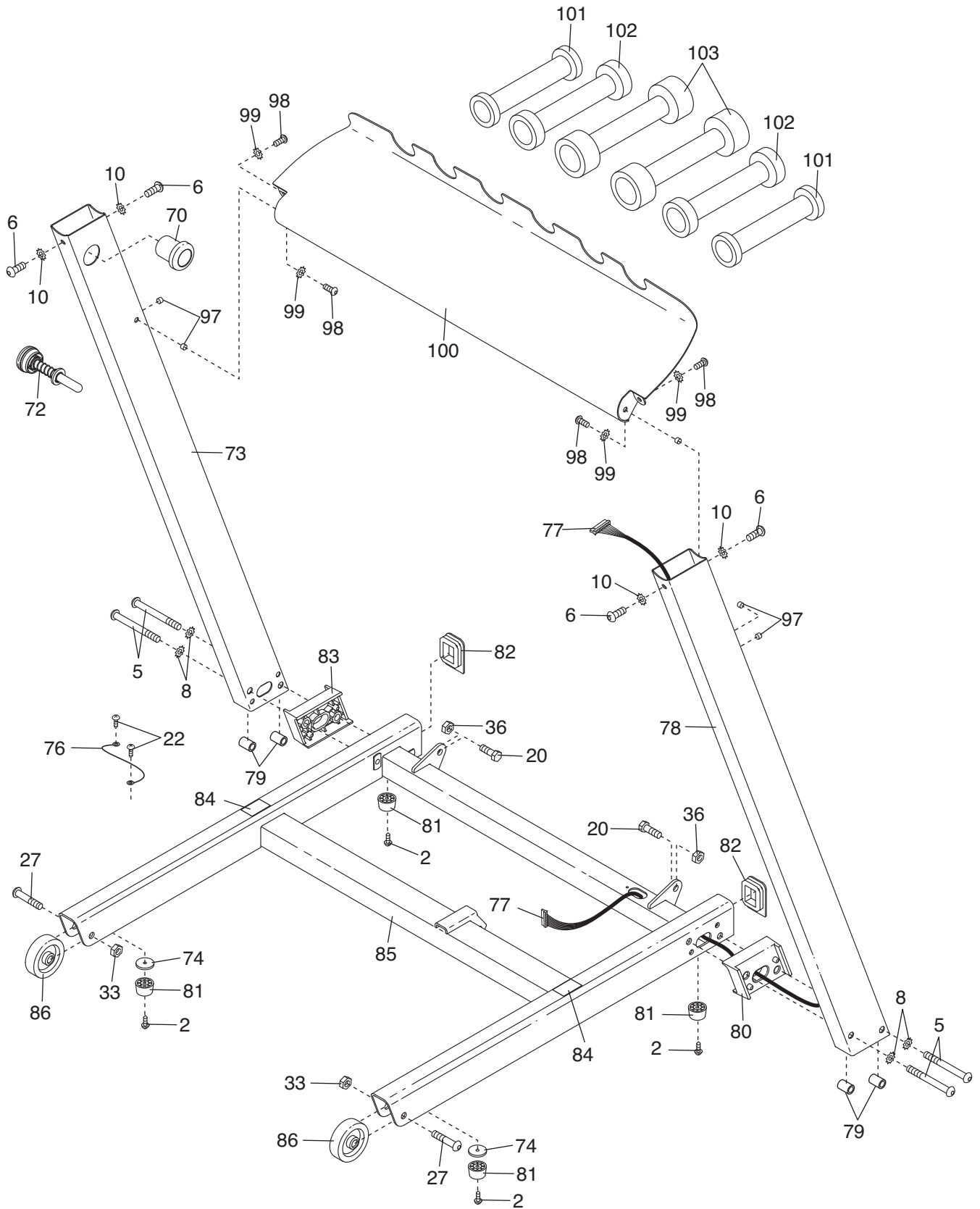

EXPLODED DRAWING D—Model No. PMTL39708.0

R0509A

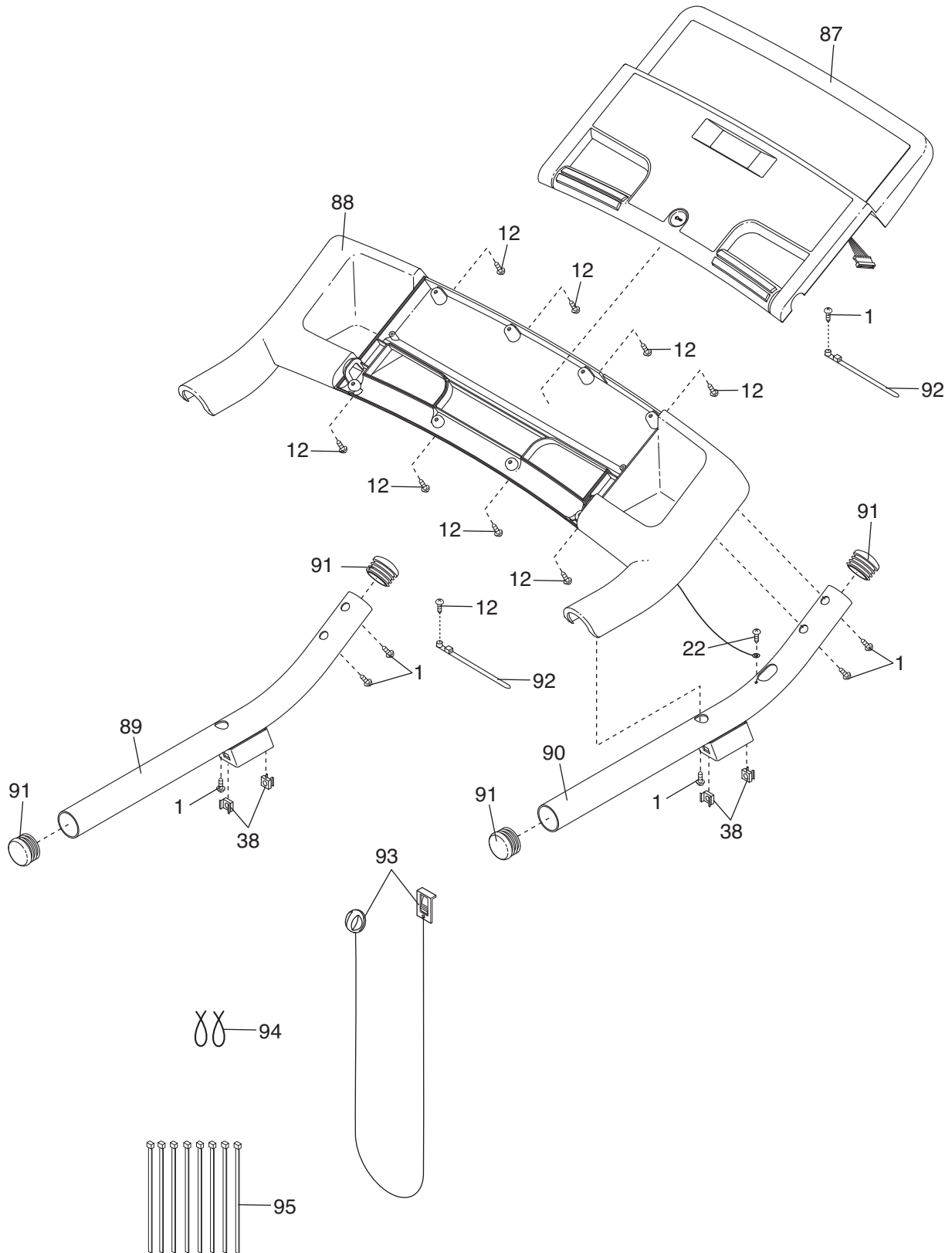

ORDERING REPLACEMENT PARTS

To order replacement parts, please see the front cover of this manual. To help us assist you, be prepared to provide the following information when contacting us:

- the model number and serial number of the product (see the front cover of this manual)
- the name of the product (see the front cover of this manual)
- the key number and description of the replacement part(s) (see the PART LIST and the EXPLODED DRAWING near the end of this manual)

LIMITED WARRANTY

IMPORTANT: You must register this product within 30 days of the purchase date to avoid added fees for service needed under warranty. Go to www.proformservice.com/registration.

ICON Health & Fitness, Inc. (ICON) warrants this product to be free from defects in workmanship and material, under normal use and service conditions. The drive motor is warranted for three (3) years after the date of purchase. Parts and labor are warranted for ninety (90) days after the date of purchase.

This warranty extends only to the original purchaser. ICON's obligation under this warranty is limited to repairing or replacing, at ICON's option, the product through one of its authorized service centers. All repairs for which warranty claims are made must be preauthorized by ICON. If the product is shipped to a service center, freight charges to and from the service center will be the customer's responsibility. For replacement parts shipped while the product is under warranty, the customer will be responsible for a minimal handling charge. For in-home service, the customer will be responsible for a minimal trip charge. This warranty does not extend to any damage to a product caused by or attributable to freight damage, abuse, misuse, improper or abnormal usage, or repairs not provided by an ICON authorized service center; to products used for commercial or rental purposes or as store display models; or to products transported or purchased outside the US. No other warranty beyond that specifically set forth above is authorized by ICON.

ICON is not responsible or liable for indirect, special, or consequential damages arising out of or in connection with the use or performance of the product; damages with respect to any economic loss, loss of property, loss of revenues or profits, loss of enjoyment or use, or costs of removal or installation; or other consequential damages of whatsoever nature. Some states do not allow the exclusion or limitation of incidental or consequential damages. Accordingly, the above limitation may not apply to you.

The warranty extended hereunder is in lieu of any and all other warranties, and any implied warranties of merchantability or fitness for a particular purpose are limited in their scope and duration to the terms set forth herein. Some states do not allow limitations on how long an implied warranty lasts. Accordingly, the above limitation may not apply to you.

This warranty gives you specific legal rights. You may also have other rights that vary from state to state.

ICON Health & Fitness, Inc., 1500 S. 1000 W., Logan, UT 84321-9813

Free Manuals Download Website

<http://myh66.com>

<http://usermanuals.us>

<http://www.somanuals.com>

<http://www.4manuals.cc>

<http://www.manual-lib.com>

<http://www.404manual.com>

<http://www.luxmanual.com>

<http://aubethermostatmanual.com>

Golf course search by state

<http://golfingnear.com>

Email search by domain

<http://emailbydomain.com>

Auto manuals search

<http://auto.somanuals.com>

TV manuals search

<http://tv.somanuals.com>