



MOSFET POWER AMPLIFIERS

Installation Instructions / Owner's Manual

HA400 • HA600 • HA1000 • HA740 • HA1040
HA700M • HA1000M



PROFILE

INTRODUCTION

Congratulations on your purchase of a Baja state-of-the-art power amplifier. Your selection of a Baja car audio product indicates a true appreciation of fine musical reproduction. Whether adding to an existing system or including your Baja amplifier in a new system, you are certain to notice immediate performance benefits.

KEEP YOUR SALES RECEIPT

Take this time to attach your sales receipt to the manual and put in a safe place. In case of any unforeseen reason this product may need warranty service, your receipt will be necessary to establish purchase date.

RECOMMENDATION

A power amplifier's performance is only as good as its installation. Proper installation will maximize the systems over all performance. It is recommended that you have our product installed by an authorized Profile retailer. However, if you decide to install it yourself, please carefully read through this manual and take your time to do a quality installation.

IMPORTANT! Before making any connections, disconnect the cars battery until the installation is completed to avoid possible damage to the electrical system.

WARNING!

Exposure to high power sound system can cause hearing loss or damage. Listening to your system at loud levels while driving, will impair your ability to hear traffic sounds and emergency vehicles. Use common sense when listening to your system.

Serial # _____

Model # _____



SAFETY PRECAUTIONS

Fuse amplifier's power wire at the battery.

Be sure to fuse the power wire within 12" of the car's battery. This will protect the car's battery in case of a short circuit between the power amplifier and battery. **THIS IS A MUST.** The amplifier's built-in fuse will only protect the power amplifier and not the car's battery! The fuse value is based on the amplifiers rated power and how many amplifiers will be run off the same power wire. Please see the specification section at the back of this manual for your amplifiers rated value.

Use high grade wires and connectors.

To ensure maximum power transfer and secure safe connections, it is recommended to use high grade wires and terminal rings (for connection at battery)

Do not run any wires underneath vehicle.

Exposed wires have a chance of being cut or damaged. It is best to run all wires through the vehicle under the carpet and/or side panels. This lends to a cleaner installation and less risk of damage.

Use caution when mounting amplifier.

Remember there are many electrical wires, gas lines, vacuum lines, brake lines as well as a gas tank in the automobile. Make sure you know where they are when mounting the amplifier to avoid puncturing lines, shorting wires or drilling holes in the gas tank.

Run signal wires away from electrical wires

To avoid possibility of induced noise from the car's electrical system (i.e. popping noises or engine noise), run wires away from the car's electrical wiring.

Make all ground wires as short as possible and at the same point.

In order to reduce the chance of ground loops (i.e. engine noise), make the grounding wire as short as possible to reduce the wire's resistance. Also, when using multiple components, make sure all units are grounded at the same point.

Avoid sharp edges when running the wires.

To avoid the possibility of power, signal or speaker shorts, be careful not to allow the amplifier's wires to come in contact with sharp edges. Use a grommet to protect the wire when running through the fire wall.

FEATURES AND BENEFITS

Built-in Crossover

The Baja amplifiers include a built-in variable **high and low pass crossovers. The crossover features a variable frequency selection of (80 Hz ~ 1.2k Hz) for precise high pass filter and (50 Hz ~ 250 Hz) for low pass filter.

** HA1000, HA700M and HA1000M models only have a 50 Hz ~ 250 Hz low pass filter.

Bass Boost

For added low frequency performance the amplifiers are equipped with a variable 0~12 dB bass boost @ 45Hz.

Treble Boost

For added high frequency performance two 4 channel amplifier models, HA740 & HA1040, are equipped with a variable 0~12 dB treble boost @ 8k Hz on channels 1 & 2.

Subsonic Filter

Models HA1000, HA700M and HA1000M are equipped with a variable 20~50 Hz subsonic filter. This filter avoids the reproduction of inaudible low frequencies on the amplifier which could damage the subwoofers because they can generate over-displacement of the subwoofer cone.

Phase Control

Mono subwoofer amplifier models, HA700M and HA1000M are equipped with a continuously adjustable phase lag control on the subwoofer(s) from 0 to 180 degrees. This control helps to align the phase shift of a subwoofer for a smooth blending.

High Level Input

All Baja amps excluding 4 Channel amplifiers have high level input connector to accept high (speaker) level signal from a factory radio without pre-amp (RCA) output.

RCA Line Output

This pre-amp signal output can be used to connect signal input to an additional amplifier or crossover at an ease without using splitters.



Tri-Mode Capable (Excluding HA700M & HA1000M models)

If so desired the amplifier may be run in stereo and mono at the same time. For example, this feature would allow you to run a pair of mids and tweeters in stereo and a subwoofer in mono.

Remote Turn-on

Automatically turns amplifier on when connected to the head unit's remote output. The amplifier will turn on and off with the head unit to save current consumption. This control also operates the reset circuit for the amplifier's protection. It must be connected with the head unit in order to reset protection circuits.

Adjustable Input Sensitivity

Allows you to fine-tune the level matching between your source and the power amplifier.

Power and Speaker Terminals

Heavy gauge power and speaker terminals with protective covers are provided for maximum power and signal transfer with minimal resistance.

Impedance Stability

For 2 and 4 channel amplifiers, they are stable with a 2 ohm or greater impedance load under stereo mode and 4 ohm or greater impedance load under bridged (mono) mode. For mono subwoofer amplifiers (HA700M & HA1000M), they are stable with a 2 ohm or greater impedance load.

Fuse(s)

This protects the amplifier against short circuits and excessive current.

DC Offset Protection

This circuit protects the output of the amplifier against DC voltage. If for some reason DC voltage is detected at the output stage, the amplifier will shut down protecting the speakers from direct current.

Short Circuit Protection

The circuit protects the amplifier from damage due to a short found in the speakers or wiring. If one of the speakers or its wiring comes in contact with ground, the amplifier will shut down. To resume normal operation, correct the problem and turn the head unit off, then back on. The amplifier will reset and play again.

Thermal Protection

To protect the amplifier circuitry against damage caused by prolonged exposure to high temperatures, a thermal protection circuit is activated if the amplifier reaches excessively high operating temperature. Once the thermal circuit is activated, the amplifier will shut down to cool off. The Amplifier will automatically turn back on once it cools down to a safe operating temperature.

Protection Indicator

This red diagnostic LED on the side panel indicates that the amplifier has gone into protection. Once on, the amplifier will have no output. To resume normal operation, turn head unit off and back on again. If the amplifier immediately goes back into protection, check for high temperature, short circuits or low impedance.



POWER CONNECTIONS

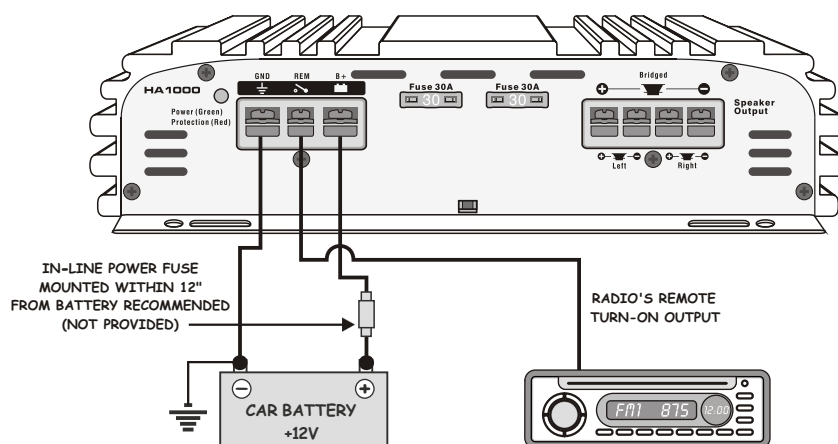

IMPORTANT! Before making any connections, disconnect the car's battery until the installation is completed to avoid possible damage to the electrical system.

Connect the B+ terminal of the amplifier to the car's battery.

At times, the amplifier will need to draw large levels of current that cannot be provided by any circuit in the car's fuse box. We recommended using a 4 to 10 gauge power wire (red) for your connections depending on the amplifier size and length of the wire. Strip one end of the wire to connect to the terminal on the amplifier marked B+. Loosen screw terminal and connect bare wire and tighten. Use caution to make sure no stray wire strands come in contact with surrounding terminals causing short circuits. Run the wire directly to the positive terminal of the car's battery. Make sure to use an in-line fuse within 12" of the car's battery to protect the electrical system and amplifier against short circuits and/or power surges.

Connect the ground terminal of the amplifier to the car's chassis.

For the ground connection, use a 4-10 gauge wire (black) to connect to the terminal marked GND and then connect it to the car's chassis. Try to keep the length of the cable as short as possible, preferably less than 6". Also make sure that the point on the car where the connection is to be made is free of paint and dirt.

Connect the remote terminal of the amplifier to a switchable +12V source.

This connection allows the amplifier to be turned on and off with the power control of the radio. If the radio has a REMOTE output wire, connect it to the amplifier's terminal marked REM (using a 16 gauge wire or heavier). Now when the radio is turned on, the amplifier will automatically turn on. This connection can also be made to the radio's Power Antenna wire.

MOUNTING LOCATION

Before you start the installation, it will be necessary to find a mounting location for the amplifier. Find a location in which the amplifier will receive adequate ventilation in order to dissipate the heat it develops during operation. Two popular mounting locations are in the trunk or under the seat.

Select the location in which you wish to mount the amplifier. **Use caution when mounting the amplifier. There are many wires, gas lines, vacuum lines, brake lines as well as a gas tank in the automobile. Make sure you know where they are when mounting the amplifier to avoid puncturing lines, shorting wires or drilling holes in the gas tank.** Once you are ready, use a pencil to mark the mounting holes in the bottom panel. After you have marked the locations of the holes move amplifier out of the way and drill small starter holes to make the tapping screws easier to install. Use provided screws to tighten down the amplifier.

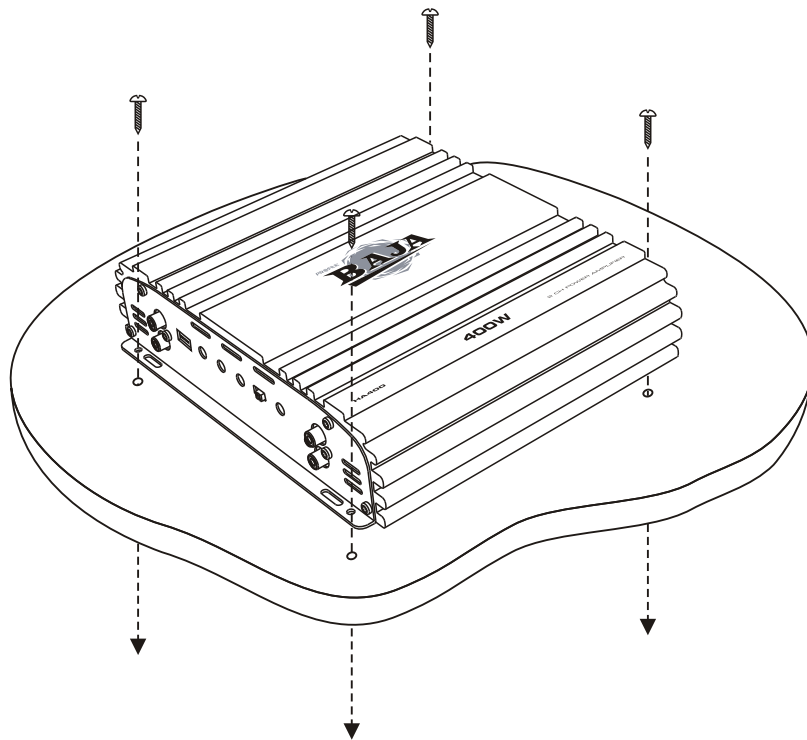

SIGNAL CONNECTIONS

Connect the RCA output of the head unit (AM/FM cassette player, CD, or DAT) to the RCA input terminals of the amplifier.

To make these connections, we recommend high quality RCA cables, which are available at your local car audio retailer. Run signal wires away from electrical wires to avoid possibility of induced noise from the car's electrical system (i.e. popping noises or engine noise). Please note that when making these connections the signal inputs correspond with the speaker outputs. For example: If you connect the radios front right RCA to "CH 1"then speaker output "CH 1" will operate the front right speaker.

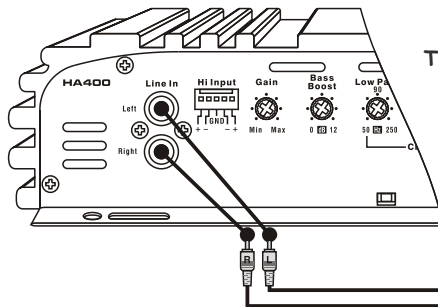

TWO CHANNEL SIGNAL CONNECTIONS

FOUR CHANNEL SIGNAL CONNECTIONS
(RADIO WITH FRONT AND REAR OUTPUTS)

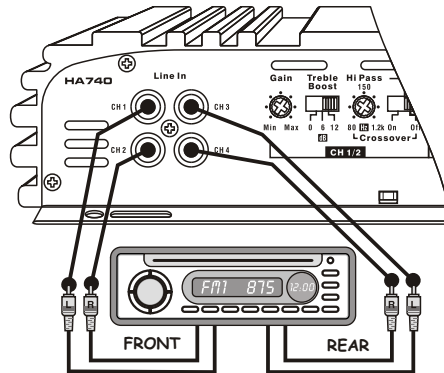

FOUR CHANNEL SIGNAL CONNECTIONS
(RADIO WITH ONLY ONE SET OF RCA'S)

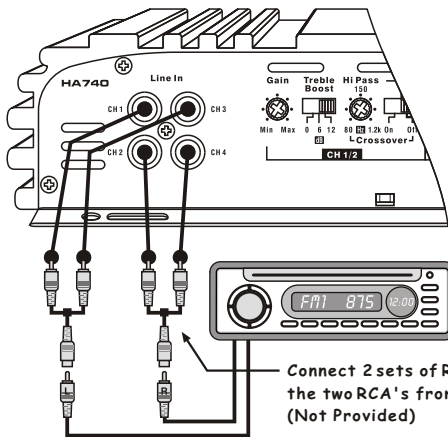

Connect 2 sets of RCA "Y" adaptors to split the two RCA's from the radio into 4 outputs (Not Provided)

HIGH LEVEL CONNECTIONS (OPTIONAL)

High level inputs have been included in all Baja amplifiers excluding 4 Channel amps to connect the amplifier to a factory radio without low-level RCA outputs. This connection will allow you to connect directly to the speaker output of the radio, without the need of an external adapter.

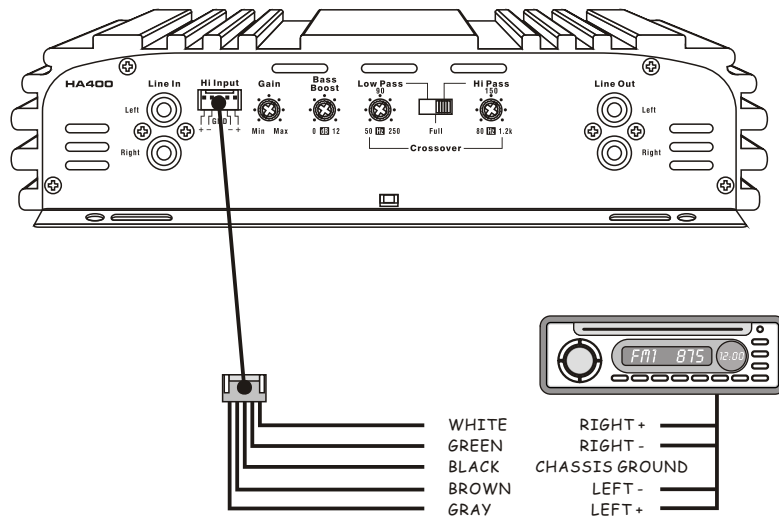

SPEAKER CONNECTIONS

Make the speaker connections using speaker wire that is at least 14 gauge or heavier.

As with any audio component, proper phasing of the amplifier and speakers is essential for strong bass response. When connecting, make sure that positive (+) from the amplifier is connected to the positive (+) of the speaker, and the same for negative (-).

TWO CHANNEL SPEAKER CONNECTIONS

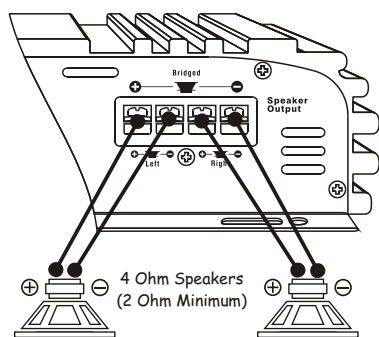

HA700M & HA1000M SPEAKER CONNECTIONS

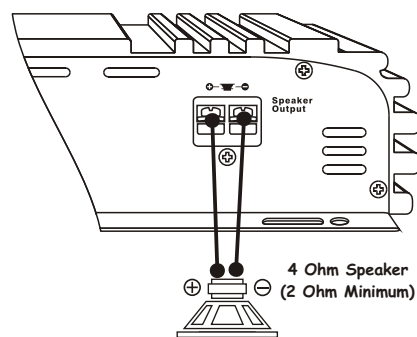

FOUR CHANNEL SPEAKER CONNECTIONS

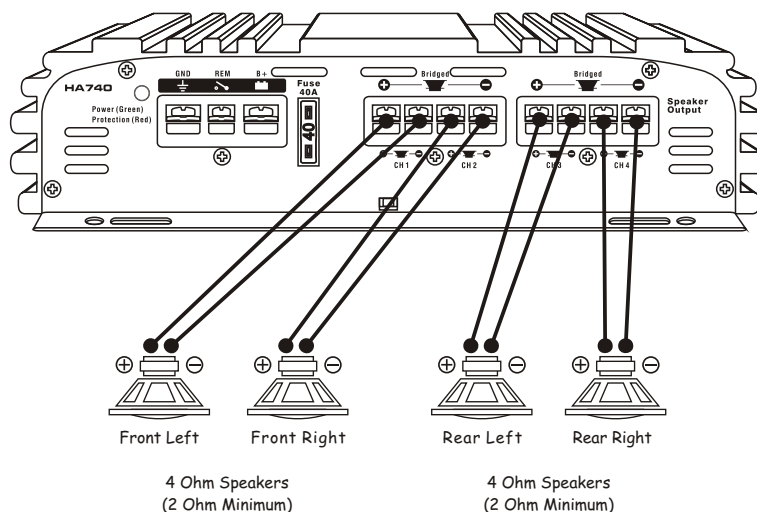

SPEAKER CONNECTIONS (BRIDGED)

Two and four channel amplifiers are capable of being bridged ** into a mono configuration. This feature allows you the flexibility of using the amplifier to drive a subwoofer or a center channel. In this configuration the amplifier sums the right and left channel to deliver one channel (mono) output.

Please note: In order for the amplifier to sum left and right signal information, both left and right RCA connections must be made.

****CAUTION!** In the bridged mode, the amplifier must see a 4 Ohm load or higher. Any lower than 4 Ohms will cause internal damage to the amplifier!

TWO CHANNEL BRIDGED SPEAKER CONNECTIONS

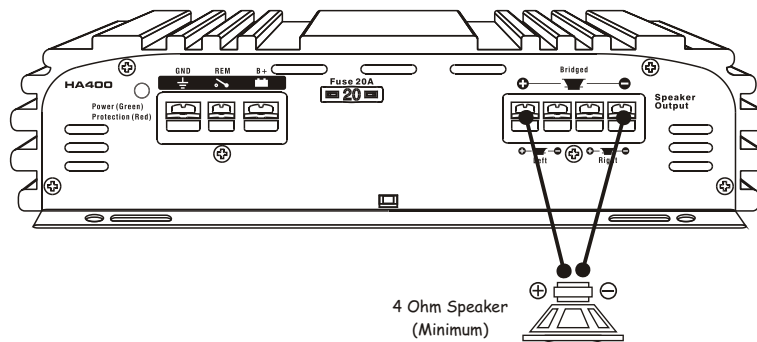

FOUR CHANNEL BRIDGED SPEAKER CONNECTIONS

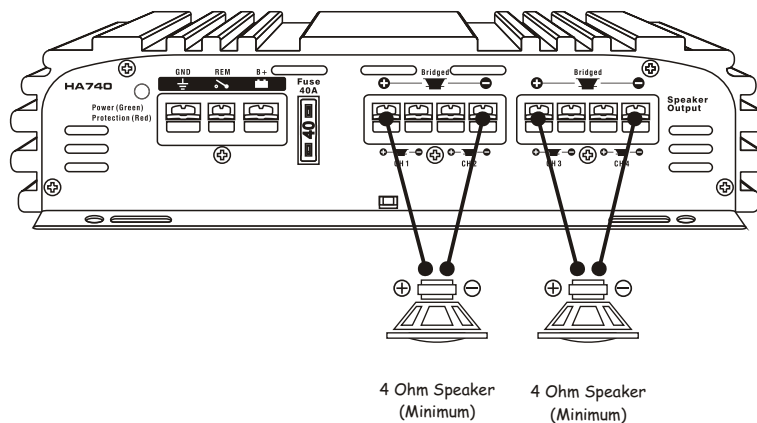

SPEAKER CONNECTIONS (TRI-MODE)

All 2 channel amplifiers are capable of running both in Mono & Stereo mode. This feature gives the amplifier the ability to run stereo satellites (midbass & tweeter) simultaneously with a mono subwoofer.

These connections are more complicated because they require the use of passive crossover networks (Not provided) to divide the frequencies to the speakers. We have included a sample diagram for 4 Ohm connections. If you wish to use multiple speakers to achieve a lower impedance and higher power, it is strongly recommended that you seek professional advice from your Profile retailer before attempting to make these connections.

Please Note: In the Tri-mode configuration, the amplifier's built-in crossover must be set to "FULL"(OFF) position.

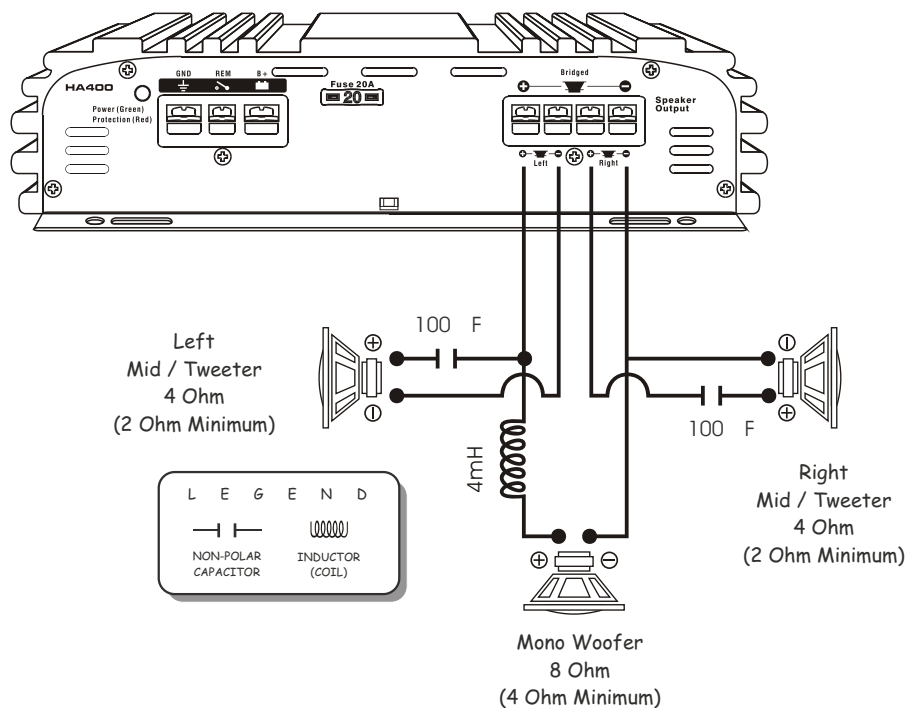

CAUTION! In Tri-mode operation, the amplifier must see a 2 Ohm load or higher for the stereo satellites and no lower than 4 Ohms for the subwoofer(s). Any lower than the above mentioned impedance will cause internal damage to the amplifier.

SETTING THE CROSSOVER AND BASS/TREBLE BOOST

(Please note: If you intend to use the amplifier in the Tri-mode configuration, it is necessary to set the crossover control to the "Full" setting in order to receive full range output)

The Baja amplifiers are equipped with a built-in variable crossover network allowing you to select the crossover type, "Low-Pass" or "High-Pass".

Low Pass Setting with Bass Boost.

If you wish to drive subwoofer(s), you would select the "Low Pass" crossover setting on the amplifier to filter out the high frequencies. This will only send low frequencies to your subwoofer(s) (see example settings below). The crossover point should be determined by the speaker's operating range that can be acquired from the speaker manufacturer. You can further enhance the bass response by using the bass boost and turning it in the clockwise direction.

You can add up to 12dB bass boost by increasing the Bass Boost control.

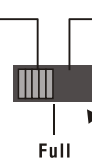

Select the crossover type on the amplifier's side panel.

(Low-pass is selected in this example for subwoofers)

High Pass Setting with Treble Boost.

If you wish to drive tweeters or midranges, you would select the "High Pass" crossover setting on the amplifier to filter out the low frequencies. This will only send high frequencies to your tweeters or midranges (see example settings below). The crossover point should be determined by the speaker's operating range that can be acquired from the speaker manufacturer. You can further enhance the high frequency response by using the treble boost and switching it to 6 or 12dB.

Note : Treble Boost is only available on channels 1 & 2 of two 4-channel amplifier models, HA740 & HA1040.

You can add up to 12dB Treble Boost by increasing the Treble Boost control.

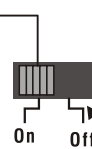
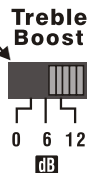

Select the crossover type on the amplifier's side panel.

(High-pass is selected in this example for tweeters/midranges)



USING SUBSONIC FILTER AND PHASE CONTROL

Using the Subsonic Filter.

Subsonic



Models HA1000, HA700M, and HA1000M are equipped with a variable 20~50Hz subsonic filter. This filter avoids the reproduction of inaudible low frequencies on the amplifier which could damage the subwoofers because they can generate over-displacement of the subwoofer cone. You would want to set the frequency point where you want the filter not to produce frequencies below that point. Generally, human ears cannot hear low frequencies below 20 Hz.

Using the Phase Control.

Phase



Mono subwoofer amplifier models, HA700M & HA1000M are equipped with a continuously adjustable phase lag control on subwoofer(s) from 0 to 180 degrees. This control helps to align the phase shift of a subwoofer for a smooth blending, without canceling the bass from other speakers or subwoofer(s).

SETTING THE GAIN

Fine tune the amplifier's input sensitivity.

Gain



The gain control has been included to allow adjustment to properly match the signal output of the radio. This is one of the most misunderstood adjustments. This is not a volume control and you will not get more power out of the amplifier in the maximum position! It may seem to deliver more output, but actually the system is only playing louder faster as you turn the volume control on the radio.

By rotating the control in the clockwise direction, the amplifier's input will become more sensitive and the music will play louder. Ideally, to properly level match the system the goal is to achieve maximum output from the amplifier without distortion at about 3/4 of the radio volume control.

To properly set the gain, start by setting the gain to its minimum position and turn the main radio volume up to 3/4 of maximum volume control. Then slowly raise the amp gain control until the system gets loud but before the point of distortion. It is very important when making these adjustments that you do not over drive the speakers that may be permanently damaged. The gain control should be adjusted very slowly. It may help to have another person assist you by adjusting the gain control while you listen for distortion.

TROUBLE SHOOTING THE SYSTEM

We have put together this trouble-shooting guide if you experience problems after installing the amplifier. Please keep in mind that the majority of problems incurred are caused by improper installation and not the equipment itself. In addition, there are many components in the system that could cause various signal problems such as inducted electrical noise and engine noise.

Before you can properly address the problem, you must first find the component that is causing the problem. This will take patience and a process of elimination.

LOOK FOR....

SOLUTION

No Output

Blown fuse	Replace
Bad RCA Cable(s)	Replace
+12V at power terminal	Check connection
+12V at remote terminal	Check connection
Grounding point clean and tight	Check for ground w/meter
Head Unit's fader not in center position	Set to center position

Low Output

Check level adjustments	Re-adjust
Bad RCA cable(s)	Replace
Improper level matching	Re-adjust

Engine Noise

Grounding points are clean and tight	Check for ground w/meter
Ground all components at same point	Ground at same point
Try different grounding point	Change for better ground
Bad RCA cable(s)	Replace
Use High Quality shielded RCA cables	Rejects inducted noise
Low Vehicle charging system and/or battery	Fix and/or replace

Protection L.E.D. Illuminated

Speaker short	Check speakers connection for short circuit
Speaker grounding out	Make sure speaker wires do not touch chassis ground
Impedance too low	Check speaker impedance (Min 2 ohm Stereo, 4 ohm Bridged)
Overheating	Check mounting location for adequate air circulation. Speaker impedance too low



SPECIFICATIONS

	HA400	HA600	HA1000
Max Power Output@4 Ohm	2 x 130W	2 x 200W	2 x 320W
RMS Power Output@4 Ohm	2 x 65W	2 x 100W	2 x 160W
Max Power Output@2 Ohm	2 x 200W	2 x 300W	2 x 500W
RMS Power Output@2 Ohm	2 x 100W	2 x 150W	2 x 240W
Bridged RMS Output@4 Ohm	1 x 200W	1 x 300W	1 x 480W
MOSFET Power Supply	Yes	Yes	Yes(Dual)
THD@RMS Power	<0.07%	<0.07%	<0.07%
Frequency Response	20Hz ~ 30kHz	20Hz ~ 30kHz	20Hz ~ 30kHz
Signal To Noise	>100dB	>100dB	>100dB
Stereo Separation	83dB	83dB	83dB
Pre-Amp Output	Yes	Yes	Yes
RCA Input Voltage	200mV ~ 7V	200mV ~ 7V	200mV ~ 7V
RCA Input Impedance	20K Ohms	20K Ohms	20K Ohms
High Level Input Impedance	42 Ohms	42 Ohms	42 Ohms
Load Impedance Stereo	2 ~ 8 Ohms	2 ~ 8 Ohms	2 ~ 8 Ohms
Load Impedance Bridged	4 ~ 8 Ohms	4 ~ 8 Ohms	4 ~ 8 Ohms
Crossover Type(12dB/Octave)	HP / FULL / LP	HP / FULL / LP	FULL / LP
LP Crossover Frequency(Variable)	50Hz ~ 250Hz	50Hz ~ 250Hz	50Hz ~ 250Hz
HP Crossover Frequency(Variable)	80Hz ~ 1.2kHz	80Hz ~ 1.2kHz	-----
Bass Boost@45Hz(Variable)	0dB ~ 12dB	0dB ~ 12dB	0dB ~ 12dB
Subsonic filter(12dB / Octave)	-----	-----	20Hz ~ 50Hz
Damping Factor	320	280	280
Fuse Value(ATC/ATO Type)	20A	40A	2 x 30A
Amp Dimensions(H x W x L)	2 1/4" x 9 11/16" x 9 1/16"	2 1/4" x 9 11/16" x 11 13/16"	2 1/4" x 9 11/16" x 14 3/16"
	HA740	HA1040	
Max Power Output@4 Ohm	4 x 120W	4 x 160W	
RMS Power Output@4 Ohm	4 x 60W	4 x 80W	
Max Power Output@2 Ohm	4 x 175W	4 x 250W	
RMS Power Output@2 Ohm	4 x 90W	4 x 125W	
Bridged RMS Output @ 4 Ohm	2 x 180W	2 x 225W	
MOSFET Power Supply	Yes	Yes	
THD@RMS Power	<0.07%	<0.07%	
Frequency Response	20Hz ~ 30Khz	20Hz ~ 30Khz	
Signal To Noise	>100dB	>100dB	
Stereo Separation	83dB	83dB	
Pre-Amp Output	Yes	Yes	
RCA Input Voltage	200mV ~ 7V	200mV ~ 7V	
RCA Input Impedance	20K Ohms	20K Ohms	
Load Impedance Stereo	2 ~ 8 Ohms	2 ~ 8 Ohms	
Load Impedance Bridged	4 ~ 8 Ohms	4 ~ 8 Ohms	
Crossover Type(12dB/Octave)	HP/FULL(CH 1 & 2) FULL/LP(CH 3 & 4)	HP/FULL(CH 1 & 2) FULL/LP(CH 3 & 4)	
LP Crossover Frequency(Variable)	50Hz ~ 250Hz	50Hz ~ 250Hz	
HP Crossover Frequency(Variable)	80Hz ~ 1.2kHz	80Hz ~ 1.2kHz	
Bass Boost@45Hz(Switchable)	0/6/12dB (CH 3 & 4)	0/6/12dB (CH 3 & 4)	
Treble Boost@8kHz(Switchable)	0/6/12dB (CH 1 & 2)	0/6/12dB (CH 1 & 2)	
Damping Factor	280	270	
Fuse Value(ATC/ATO Type)	40A	2 x 30A	
Amp Dimensions(H x W x L)	2 1/4" x 9 11/16" x 11 13/16"	2 1/4" x 9 11/16" x 14 3/16"	

SPECIFICATIONS

	HA700M	HA1000M
Max Power Output@4 Ohm	1 x 400W	1 x 650W
RMS Power Output@4 Ohm	1 x 200W	1 x 310W
Max Power Output@2 Ohm	1 x 700W	1 x 1000W
RMS Power Output@2 Ohm	1 x 350W	1 x 500W
MOSFET Power Supply	Yes	Yes
THD@RMS Power	<0.07%	<0.07%
Frequency Response	20Hz ~ 250Hz	20Hz ~ 250Hz
Signal To Noise	>100dB	>100dB
Stereo Separation	83dB	83dB
Pre-Amp Output	Yes	Yes
RCA Input Voltage	200mV ~ 7V	200mV ~ 7V
RCA Input Impedance	20K Ohms	20K Ohms
High Level Input Impedance	42 Ohms	42 Ohms
Load Impedance Mono	2 ~ 8 Ohms	2 ~ 8 Ohms
Crossover Type(12dB/Octave)	LP	LP
LP Crossover Frequency(Variable)	50Hz ~ 250Hz	50Hz ~ 250Hz
Bass Boost@45Hz(Switchable)	0 / 6 / 12dB	0 / 6 / 12dB
Subsonic Filter(12dB / Octave)	20Hz ~ 50Hz	20Hz ~ 50Hz
Phase Control(Variable)	0° ~ 180°	0° ~ 180°
Damping Factor	280	300
Fuse Value(ATC/ATO Type)	40A	2 x 30A
Amp Dimensions(H x W x L)	2 1/4" x 9 11/16" x 13"	2 1/4" x 9 11/16" x 14 3/16"

Due to continuing product improvements, specifications subject to change without notice.



PROFILE[®] LIMITED WARRANTY

Profile Consumer Electronics, Inc. warrants this product to be free from defects in material and workmanship for a period of **One (1) Year** from the date of sale to the original consumer purchaser. If this product is proven to be defective within this one year period, Profile will repair it when said product is returned, with a copy of the dated sales receipt, freight prepaid to Profile.

This warranty is valid only in the United States. This warranty does not cover any expense incurred in the removal and/or re-installation of this product. This warranty does not cover any Profile product damaged by accident, misuse, abuse, improper line voltage, fire, water, lightning, or other acts of God. This warranty is void if any parts and/or service is/are furnished by anyone other than Profile. This warranty is void if the factory applied serial number is altered or removed from the product.

This warranty does not cover cartons, cases, batteries, broken or marred cabinets, magnetic tapes, or any other accessories used in connection with this product or consequential damages due to a defect in the product.

Any implied warranties, including fitness for use and merchantability, are limited in duration to the period of the express warranty set forth above. No person is authorized to assume for Profile any other liability in connection with the sale of the product. Profile expressly disclaims liability for incidental and consequential damages that might be caused by this product. The remedies provided under this warranty are exclusive and lieu of all others.

This warranty gives you specific legal rights. You may have other rights which vary from state to state or province to province. Some states or provinces do not allow limitation on how long warranties last, so the above may not apply to you. Additionally, some states/provinces do not allow the exclusion to limitation of consequential or incidental damages, so the above limitation or exclusion may not apply to you.

* In the space below, record the model number that is located on the back of the unit along with the purchase date and location.

Model Number _____

Purchase Date _____ Where Purchased _____

RETAIN YOUR SALES RECEIPT ALONG WITH THIS CARD. IT IS YOUR ONLY VALID DOCUMENT TO RECEIVE WARRANTY SERVICE.

PRFILE® WARRANTY REPAIR POLICY

In the unlikely event of product failure, the following procedures should be followed

- 1) The unit must be under the 1-year warranty period.
- 2) The unit must have no physical damage.
- 3) A copy of the original proof of purchase must be sent with the unit.
- 4) Include a brief description of the problem or failure with the unit.
- 5) Include the return street address and daytime telephone number.
- 6) Allow 2~3 weeks for repair (this period includes shipping time).

Send unit to : **PROFILE CONSUMER ELECTRONICS, INC.**
15060 SHOEMAKER AVE.
SANTA FE SPRINGS, CA 90670
TEL: (562) 404-9393

Note: All units failing to meet the above requirements will be subject to a charge and or may not be repaired.



PROFILE CONSUMER ELECTRONICS, INC.
15060 SHOEMAKER AVE.
SANTA FE SPRINGS, CA 90670
TEL: (562) 404-9393 • FAX: (562) 404-9433
www.profileusa.com

Free Manuals Download Website

<http://myh66.com>

<http://usermanuals.us>

<http://www.somanuals.com>

<http://www.4manuals.cc>

<http://www.manual-lib.com>

<http://www.404manual.com>

<http://www.luxmanual.com>

<http://aubethermostatmanual.com>

Golf course search by state

<http://golfingnear.com>

Email search by domain

<http://emailbydomain.com>

Auto manuals search

<http://auto.somanuals.com>

TV manuals search

<http://tv.somanuals.com>