

PENTAX

**BINOCULARS
FERNGLÄSER
JUMELLES
BINOCOLI
PRISMÁTICOS**

雙筒望遠鏡
双眼鏡

OWNER'S MANUAL
BEDIENUNGSANLEITUNG
MANUEL D'UTILISATION
ISTRUZIONI
MANUAL DE INSTRUCCIONES
用戶備用冊
使用說明書

Complete **ZOOM**
8-16x21 UCF ZOOM

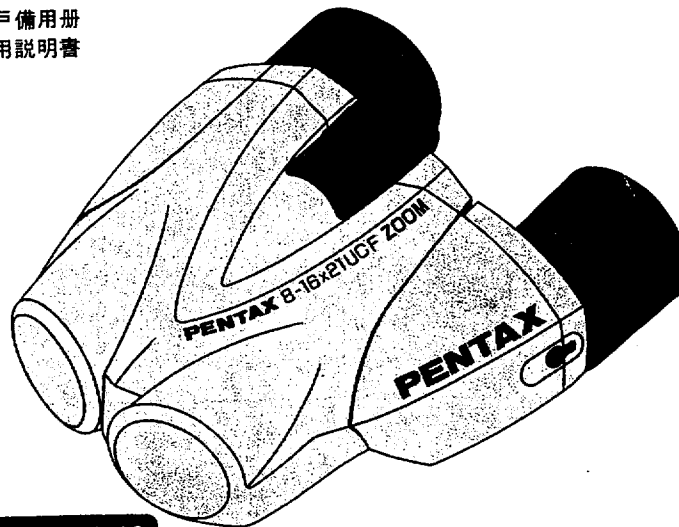

- ⚠ **WARNINGS**
Never attempt to look into the sun with binoculars.
- ⚠ **WARNUNG**
Blicken Sie nie mit einem Fernglas in die Sonne.
- ⚠ **ATTENTION**
N'observez jamais le soleil avec vos jumelles.
- ⚠ **AVVERTENZE**
Non guardate il sole attraverso il binocolo.
- ⚠ **ATENCION**
Nunca intente mirar al sol con prismáticos.
- ⚠ **警告**
切勿使用望遠鏡觀望太陽。
- ⚠ **警告**
双眼鏡で太陽を絶対見ないで下さい。



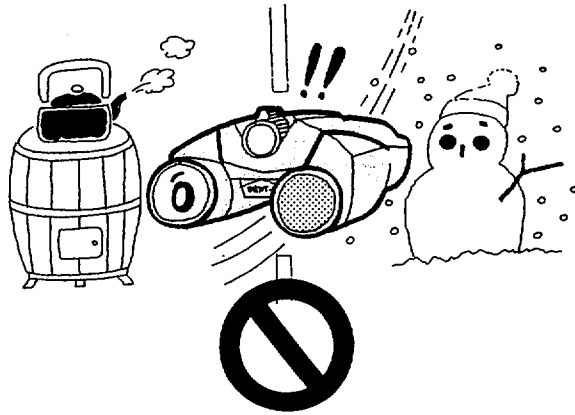
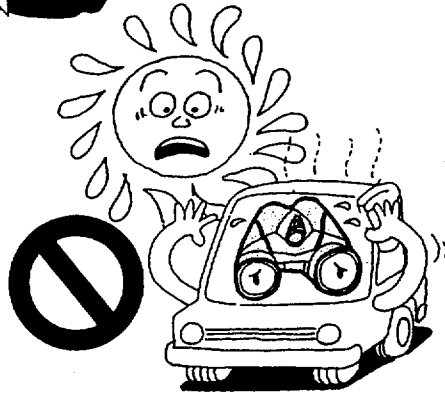
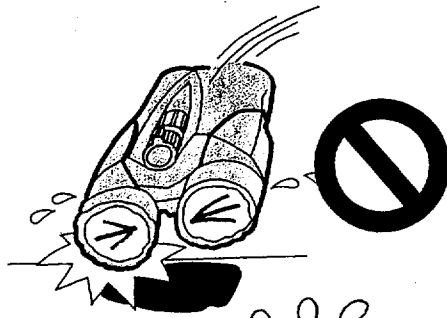
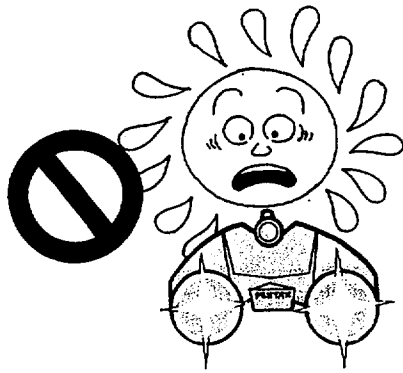

Features

Pentax 8-16x21 UCF (Uni-barrel Center Focusing) zoom binoculars cover a wide magnification range from 8X to 16X, offering excellent adaptability for virtually all viewing situations and provide clear and sharp images even at the edges of the field of vision. The binoculars employ a centralized control system with zoom, focus, and diopter adjusting rings positioned on the center axis to dramatically improve ease of operation and control. This comprehensive zoom range combined with centralized control system means that the Pentax 8-16x21 UCF zoom binoculars are unparalleled in ease-of-use and versatility.

⚠ Warnings

1. To avoid serious eye damage, **NEVER** look at the sun using the binoculars. Serious damage to the retina, or total loss of eyesight may occur.
2. Do not leave the binoculars in direct sunlight. Sun rays passing through the binoculars will be intensified, and should they focus on flammable materials, fire may occur.

⚠ Safety precautions

1. Do not use the binoculars while walking as depth perception and peripheral vision are dramatically altered.
2. Caution should be taken when adjusting the binocular barrels to avoid fingers being pinched.
3. Using the binoculars continuously for a long time may cause inflammation of the skin around the eyes where the eyepiece come in contact with the skin. Consult a physician if any symptoms are noticed.
4. Do not swing the binoculars by the neck strap.
5. Be careful with the vinyl bag. Keep the vinyl bag in which the binoculars are packed for delivery, and all other vinyl bags, out of the reach of children and infants, as there is a risk of suffocation.

Handling Precautions

1. Do not apply excessive force or pressure when operating the focus wheel, zoom ring, the diopter adjusting ring, or when mounting the binoculars on a tripod. (Please use the optional Tripod Adapter U to mount the binoculars on a tripod.)
2. Do not drop the binoculars or subject them to strong vibration, impact or pressure.
3. Never expose the binoculars to high temperature (Over 60 degrees centigrade or 140 degrees Fahrenheit). Avoid leaving the binoculars for an extended period of time in a hot humid place such as in a car parked in the sun or near a heater, as this could cause the binoculars to become deformed.
4. Care should be taken when the binoculars are taken between two places with widely varying temperatures difference as condensation or, in extreme cases, icelets may form that could cause rust or other damage. In such circumstances the binoculars should be covered so that the temperature change will be as gradual as possible. After the temperatures have stabilized, the binoculars may be uncovered and used again.
5. Reasonable care should be taken to prevent exposure to dirt, mud, sand, moisture, toxic gas, water, salt water, or any other substance which may penetrate the inside of the binoculars, or the mechanisms. These substances may cause internal damage or render the binoculars inoperable.
6. Keep in mind that the binoculars are not water or weather resistant. If water splashes onto the binoculars, allow them to dry naturally, then wipe away any residual dirt with a clean, soft, dry cloth.
7. Binoculars should be stored in a well-ventilated place to prevent fungus growth. Never store them in a closet with mothballs or in an environment where chemicals are handled.

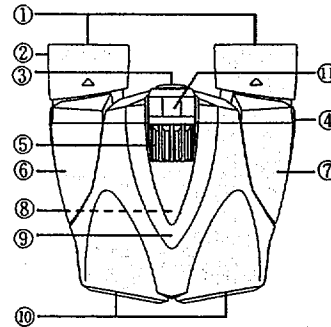

Names of Parts

- ① Eyepiece Lens
- ② Eyepiece Ring
- ③ Diopter Adjusting Ring (fully-retracted)
- ④ Neck Strap Hook
- ⑤ Central Focusing Wheel
- ⑥ Right Barrel
- ⑦ Left Barrel
- ⑧ Tripod Socket (bottom)
- ⑨ Uni-Barrel
- ⑩ Objective Lens
- ⑪ Zoom ring

How to use

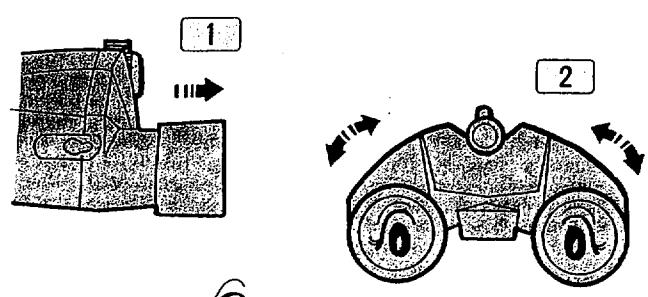

1. Eyepiece Rings
 For easy viewing, the binoculars are usually operated with the eyepiece rings pulled out. When wearing glasses, push back the eyepiece ring to the original position. When pulling out the eyepiece ring, do not pull too strong. Do not attempt to rotate it.

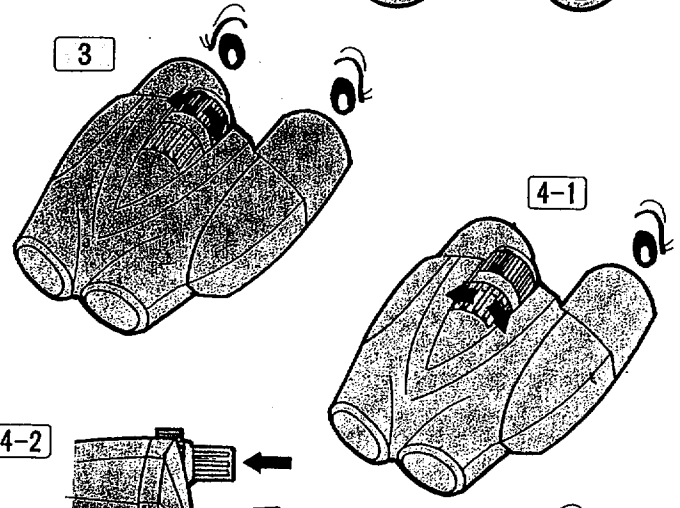

2. Adjusting the Eyepiece Width
 While looking at a distant object through both the right and left eyepiece lenses, adjust the barrels so that eyepieces are comfortably in front of your eyes.

3. Zooming
 Rotating the zoom ring to the left decreases magnification. Rotating the ring to the right increases magnification.

4. Adjusting the Diopter control
 Higher resolution can be obtained when adjusting the diopter control if this adjustment is made at the highest (16X) magnification. While looking through the left eyepiece lens with the left eye only, turn the central focusing wheel to focus on a distant object sharply. (See 4-1.) Next, press the diopter adjusting ring to set it to the diopter adjustment position (as shown in 4-2.) While looking through the right eyepiece lens with the right eye, turn the diopter adjusting ring until the same object comes into sharp focus. (See 4-3.) After focusing is completed, press in the diopter adjusting ring to the original, fully-retracted position to prevent it from being turned. To view objects at different distances, focus by just turning the central focusing wheel to the right or left.

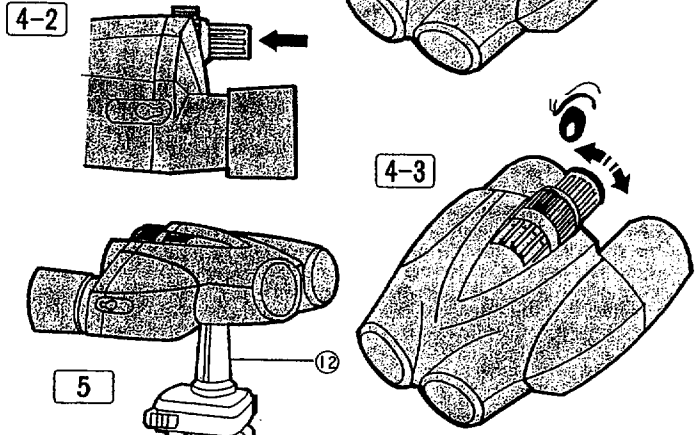

5. Mounting Binoculars on Tripod
 To mount the binoculars on a tripod, screw the optional Tripod Adapter U into the tripod socket and attach the binoculars on to the tripod.

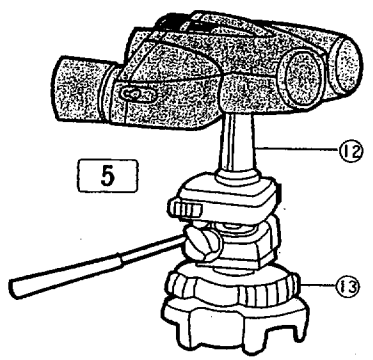

6. How to attach the Neck Strap
 To attach the neck strap to the binoculars, put the tip of the strap tack in the strap hook, and slide the strap tack to the eyepiece lens side while pressing it until it clicks. (See 6-1.) Check to see if the strap is securely attached to the binoculars by pulling the strap. The strap length can be adjusted according to your preference. It is best to provide enough slack in the strap for easy adjustment. (See 6-2.) CAUTION: Do not pull the strap in the direction perpendicular to the top of the uni-barrel.

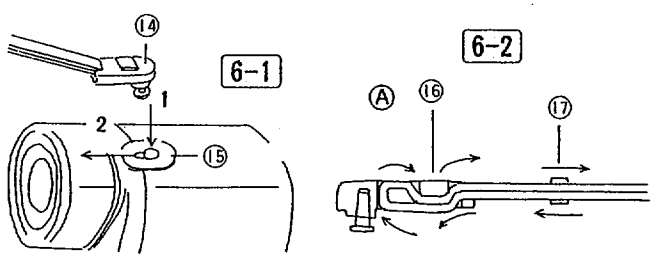

- 12 Pentax Tripod Adapter U
- 13 Tripod
- 14 Strap Tack
- 15 Strap Hook
- A How to pass the strap
- 16 Strap Clasp
- 17 Belt Ring

Specifications

Models	8-16x21UCF Zoom
Features	
Type	Porro prism, center Focusing Center Zooming (Linked-dual-Axis)
Magnification	8~16X
Effective diameter of objective lens	21 mm
Real field of vision	5.0° (8X) ~3.0° (16X)
Field of vision at 1000m Field of vision at 1000yards	87m(8X)~52m(16X) 261ft(8X)~156ft(16X)
Exit pupil aperture	2.6 mm(8X)~1.3 mm(16X)
Relative brightness	6.7(8X)~1.7(16X)
Eye relief	14 mm(8X)
Focusing range	About 3m to infinity About 9.8 ft to infinity
Eye width (ocular distance) adjustable range	55 mm to 73 mm 2.2 in to 2.9 in.
Height & width	115 mm×108 mm 4.5 in×4.3 in.
Thickness	61 mm 2.4 in.
Weight	330g 11.6 oz.
Accessories	Eyepiece Lens cap, Case, Neck strap



旭光学工業株式会社
〒174-8639 東京都板橋区前野町2-36-9
ペンタックス販売株式会社
〒100-0014 東京都千代田区家田町1-11-1

●お問い合わせは次の各サービス窓口へ

ペンタックスフォーラム	〒163-0401 東京都新宿区西新宿2-1-1 新宿三井ビル1階(登録書)	☎03(3348)2941(代)
旭光学 東京サービスセンター	〒104-0061 東京都中央区銀座西8-10 (土曜交通点交番並み)	☎03(3571)5621(代)
〃 札幌サービスセンター	〒060-0010 札幌市中央区北10条西18-36 ペンタックス札幌ビル4階	☎011(612)3231(代)
〃 仙台サービスセンター	〒981-3133 仙台市東区泉中央1-7-1 千代田生命泉中央ビル5階	☎022(371)6663(代)
〃 新潟サービスセンター	〒951-8067 新潟市本町通7番町1153 新潟本町通ビル4階	☎025(224)8391(代)
〃 横浜サービスセンター	〒231-0032 横浜市中区不老町1-6-9 横浜エクセレントVビル3階	☎045(681)8771(代)
〃 静岡サービスセンター	〒420-0858 静岡市広野町24-2 住友建設ビル5階	☎054(255)6308(代)
〃 名古屋サービスセンター	〒461-0001 名古屋市中区東1-19-8	☎052(962)5331(代)
〃 大阪サービスセンター	〒542-0081 大阪市中央区南船場1-17-9 パールビル2階	☎06(271)7996(代)
〃 広島サービスセンター	〒733-0035 広島市西区南観音3-5-2 空港通りビル6階	☎082(234)5681(代)
〃 福岡サービスセンター	〒810-0602 福岡市博多区中洲中島町3-8 パールビル1階	☎092(281)6898(代)
〃 お客様相談室	〒104-0061 東京都中央区銀座西8-10 (土曜交通点交番並み)	☎03(3572)6479



ペンタックスウイジョン株式会社 〒164-0011
東京都中野区中央2丁目37番地3号

札幌営業所	〒060-0010 札幌市中央区北10条西18丁目36番地 ペンタックス札幌ビル	☎011(615)7701(代)
仙台営業所	〒980-0811 仙台市青葉区一番町1丁目1番41号 日動仙台ビル7F	☎022(227)9255(代)
東京営業所	〒164-0011 東京都中野区中央2丁目37番3号	☎03(3367)3011(代)
名古屋営業所	〒461-0001 名古屋市中区東1丁目19番8号 ペンタックスビル2F	☎052(962)6711(代)
大阪営業所	〒542-0081 大阪市中央区南船場1丁目17番9号 パールビル4F	☎06(262)0121(代)
広島営業所	〒730-0041 広島市中区小町3丁目25番地 住金物産 広島ビル5F	☎082(246)9331(代)
高松営業所	〒760-0028 高松市鍛冶屋町6丁目12番地 池田ビル3F	☎0878(21)4833(代)
福岡営業所	〒812-0013 福岡市博多区博多駅前1丁目1番33号 はかた近代ビル4F	☎092(472)0635(代)

※日曜・祝日および土曜日は原則として休みます。
ただし、年末年始を除きペンタックスフォーラムは年中無休です。

PENTAX

- Asahi Optical Co., Ltd. 11-1, Nagata-cho 1-chome, Chiyoda-ku, Tokyo 100-0014, JAPAN
(Internet: //www.pentax.co.jp/)
- Pentax Europe n.v. Weveldlaan 3-5, 1930 Zaventem, BELGIUM
(Internet: //www.pentaxeuropa.com/)
- Pentax GmbH. Julius-Vosseler-Strasse, 104, D-22527 Hamburg, GERMANY
(Internet: //www.pentax.de/)
- Pentax U.K. Limited Pentax House, Heron Drive, Langley, Slough Berks SL3 8PN, U.K.
- Pentax France S.A. 12/14, rue Jean Poulmarch, 95100 Argenteuil Cedex, FRANCE
- Pentax Benelux B.V. (for Netherlands) Spinveld 25,4815 HR Breda, NETHERLANDS
(for Belgium & Luxemburg) Weveldlaan 3-5, 1930 Zaventem, BELGIUM
- Pentax (Schweiz) AG Industriestrasse 2,8305 Dietikon, SWITZERLAND
- Pentax Scandinavia AB P.O. Box 650,75127 Uppsala, SWEDEN
- Pentax Corporation 35 Inverness Drive East, Englewood, Colorado 80112, U.S.A.
(Internet: //www.pentax.com/)
- Pentax Canada Inc. 3131 Universal Drive, Mississauga, Ontario L4X 2E5, CANADA

- ☆ SPECIFICATIONS ARE SUBJECT TO CHANGE AT ANY TIME WITHOUT NOTIFICATION OR ANY OBLIGATION ON THE PART OF THE MANUFACTURER.
- ☆ DIE TECHNISCHEN DATEN DES PRODUKTES KÖNNEN JEDERZEIT OHNE WEITERE VERPFLICHTUNGEN SEITENS DES HERSTELLERS GEÄNDERT WERDEN.
- ☆ LES CARACTERISTIQUES DE CET APPAREIL SONT SUJETTES A MODIFICATIONS SANS AUCUN ENGAGEMENT DE LA PART DU FABRICANT.
- ☆ LE CARATTERISTICHE POSSONO ESSERE SOGGETTE IN QUALSIASI MOMENTO A VARIAZIONI SENZA ALCUN PREAVVISO O OBBLIGO DA PARTE DEL FABBRICANTE.
- ☆ LA FICHA TECNICA ES SUSCEPTIBLE DE MODIFICACION EN CUALQUIER MOMENTO SIN NOTIFICACION NI OBLIGACION ALGUNA POR PARTE DEL FABRICANTE.
- ☆ SPECIFICATIES KUNNEN TE ALLEN TIJDE WORDEN GEWIJZIGD ZONDER VOORAFGAANDE KENNISGEVING OF ENIGE VERPLICHTING VAN DE KANT VAN DE FABRIKANT.
- ☆ 上述部份規格如有更改，請恕廠方不另行通知。
- ☆ 記載内容の仕様などの一部が予告なく変更される場合があります。

Free Manuals Download Website

<http://myh66.com>

<http://usermanuals.us>

<http://www.somanuals.com>

<http://www.4manuals.cc>

<http://www.manual-lib.com>

<http://www.404manual.com>

<http://www.luxmanual.com>

<http://aubethermostatmanual.com>

Golf course search by state

<http://golfingnear.com>

Email search by domain

<http://emailbydomain.com>

Auto manuals search

<http://auto.somanuals.com>

TV manuals search

<http://tv.somanuals.com>