

INSTALLATION AND OPERATION INSTRUCTIONS

UTILITY COOLERS

MODEL NOS.

US4KP

US10KP

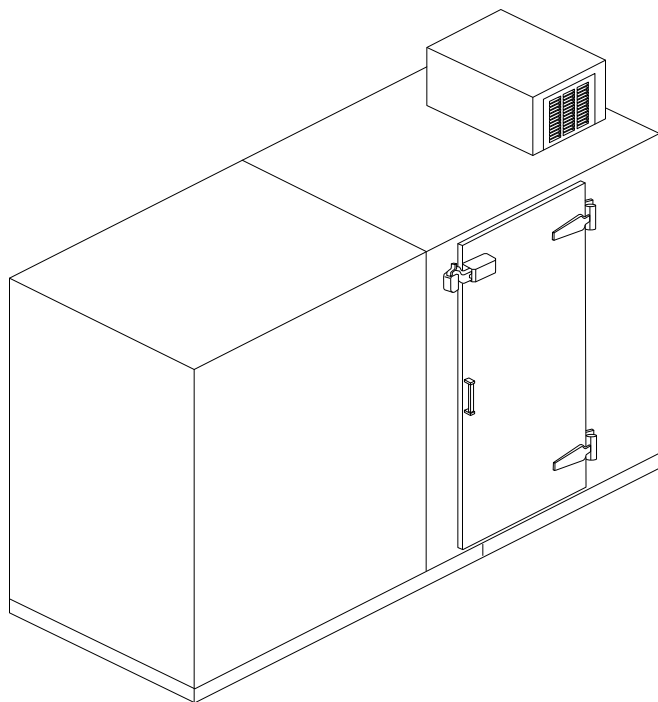

IMPORTANT INFORMATION

This manual has been prepared to assist you in the installation of your Utility Cooler and to acquaint you with its operation and maintenance.

We dedicate considerable time to ensure that our products provide the highest level of customer satisfaction. If service is required, your dealer can provide you with a list of qualified service agents. For your own protection, never return merchandise for credit without our approval.

We thank you for selecting a Perlick product and assure you of our continuing interest in your satisfaction

IMPORTANT WARRANTY INFORMATION

To register your product, visit our web site at (www.perlick.com). Click on "Commercial", then "Service". You will see the link to "Warranty Registration Form". You must complete and submit this form or the installation date will revert back to the ship Date.

Table of Contents

Cabinet Specifications	2
Preparing for Assembly	
Tools Required	3
Pre-Assembly	3
Placing the Utility Cooler	3
Cam Lock Fastening Method	3
Assembling the Cooler	
Preparing the Floor	4
Assembly	4
Assembly Order-Four Keg Cooler	5
Assembly Order-Ten Keg Cooler	6
General Information	
Electrical Requirements	7
Starting the Cooler	7
Temperature Control	7
Ventilation Requirements	7
Cleaning the Condensing Unit	7
Warranty Information	7
Replacement Parts	8
Wiring Diagrams	
Four Keg Self-contained	9
Ten Keg Self-contained	10



8300 West Good Hope Road • Milwaukee, WI 53223 • Phone 414-353-7060 • Fax 414-353-7069
Toll Free 800-558-5592 • E-Mail: Perlick@Perlick.com • www.Perlick.com

Form No. Z2026
Rev 01.28.09

Installation and Operating Instructions

Sizes and Specifications, Utility Coolers - Self Contained

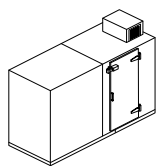

MODEL NOS.		US4KP	US10KP
KEG CAPACITY		4	10
DIMENSIONS EXTERIOR (mm)	Length	47" (1194)	93" (2362)
	Depth	47" (1194)	47" (1194)
	Height	77" (1956)	79" (2007)
CONDENSING UNIT		1/3	1/2
FULL LOAD AMPS		8.5	10.2
MAX. FUSE		15	15
SHIPPING WEIGHT lbs. (kg)		700 (318)	1150 (522)
EXTERIOR	Floor: Stucco galvanized steel. Roof, Walls & Doors: Stucco galvanized steel painted grey.		
INTERIOR	Floor: 16 gauge slip resistant stainless steel. Roof, Walls & Doors: 26 gauge stucco galvanized steel.		
ELECTRICAL	115 V, 60 Hz. 1ph AC. Junction box provided.		
PLUMBING	Evaporator condensate drains through access hole in wall. 20" x 1/2" I.D. drain line provided.		
REFRIGERATION	R134a refrigerant.		
INSULATION	4" UL Class 1 urethane foam. Flame Spreading Rate: 25 or less. Smoke Develop Rating: 450 or less.		
DOORS	Flush-mounted with cam-lift chrome hinges, automatic door closer, magnetic gaskets, chrome pull handle. Standard right hinged. Door size: 30" W x 55" H.		
FEATURES	Light "ON" indicator in door. Light switch and fixture installed on evaporator. Thermometer furnished loose.		
OPTIONAL ACCESSORIES	• Floor rack • Keg shelf kit		

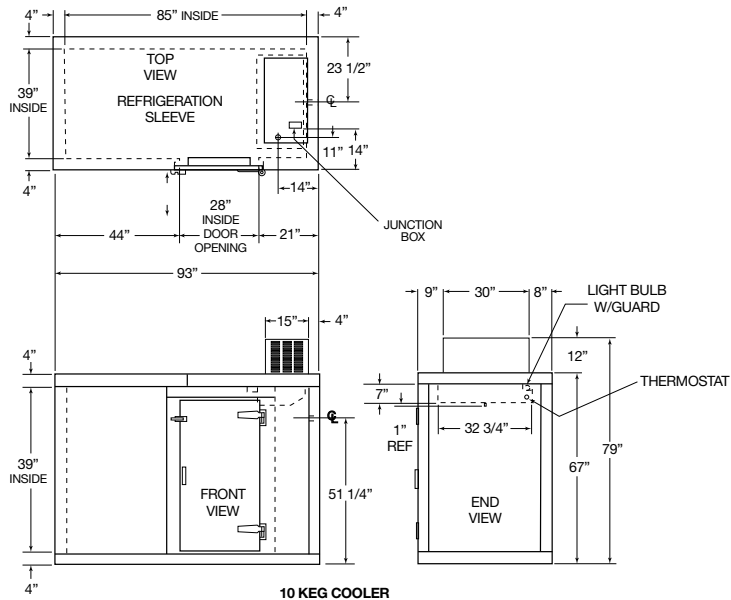
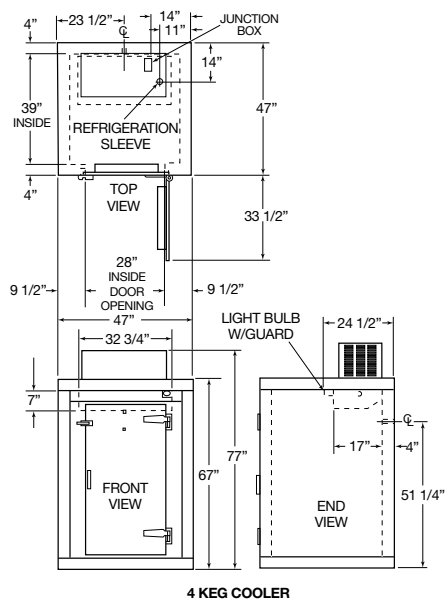

Perlick is committed to continuous improvement. Therefore, we reserve the right to change specifications without prior notice.

Preparing the Cabinet for Use

Tools Required

- Tape Measure.
- Chalk Line.
- Caulking Gun.
- Caulk (provided).
- Clam Lock Wrench (provided).
- Level.
- Screw Driver.
- Shims.

Pre-Assembly

Some panels have been protected with a strip-pable film to prevent surface damage. Remove this film before assembly. It is very difficult to remove it from the panel edges after panels have been joined together. **Note: Do not store panels with protective film in sunlight or high temperature areas for an extended period of time.**

Placing the Utility Cooler

This utility cooler should not be installed tight against any building or adjacent cooler wall. A minimum of two inches must be provided for air circulation. Shims for leveling the floor must also be incorporated into overall height and clearance requirements.

Remote Units: A minimum four inch clearance is required between the top of the utility cooler and the ceiling of the building in which it is being installed.

Self-contained Units: Sufficient clearance above the cooler must be allowed for ceiling panel and condensing unit installation. For ventilation requirements, see page 7.

The Cam Lock Fastening Method

This utility cooler utilizes the cam-lock fastening method. (See illustration on below.)

Insert the cam lock wrench into the lock before the panels are pushed together. Turn the handle Cam Hole counterclockwise as far as it will go to fully cock the

cam. Note: The cam must be fully cocked to assure proper locking. The panels should then be pushed together tightly and locked by turning the wrench clockwise.

Plugs are provided to insert in cam-lock holes after final assembly.

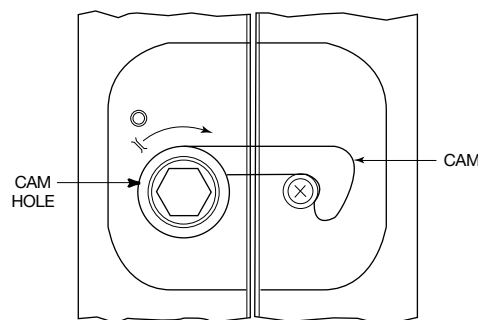

General Information

Preparing the Floor

Snap a chalk line on the building floor to establish cooler location. Place floor panel(s) on the floor and check for level. A level floor is essential to ensure that vertical panels will be plumb. If shimming is required to level the sections, the shims must extend under the entire section, not just the edges. Shims should be used at each end, at all wall seams, and at each floor seam. They should not be spaced further than 24 inches apart.

Assembly

1. Place (do not slide) all sections into position.
2. Each panel is numbered on the edge. For a four keg cooler, follow the assembly order on page 5. For a ten keg cooler, the assembly order appears on page 6.
Note: If ceiling height in building is restricted, panel(s) can be carried through the door opening and placed into position from inside the cooler.
3. Install cap plugs in all cam-lock holes.
4. Seal cooler to the floor.

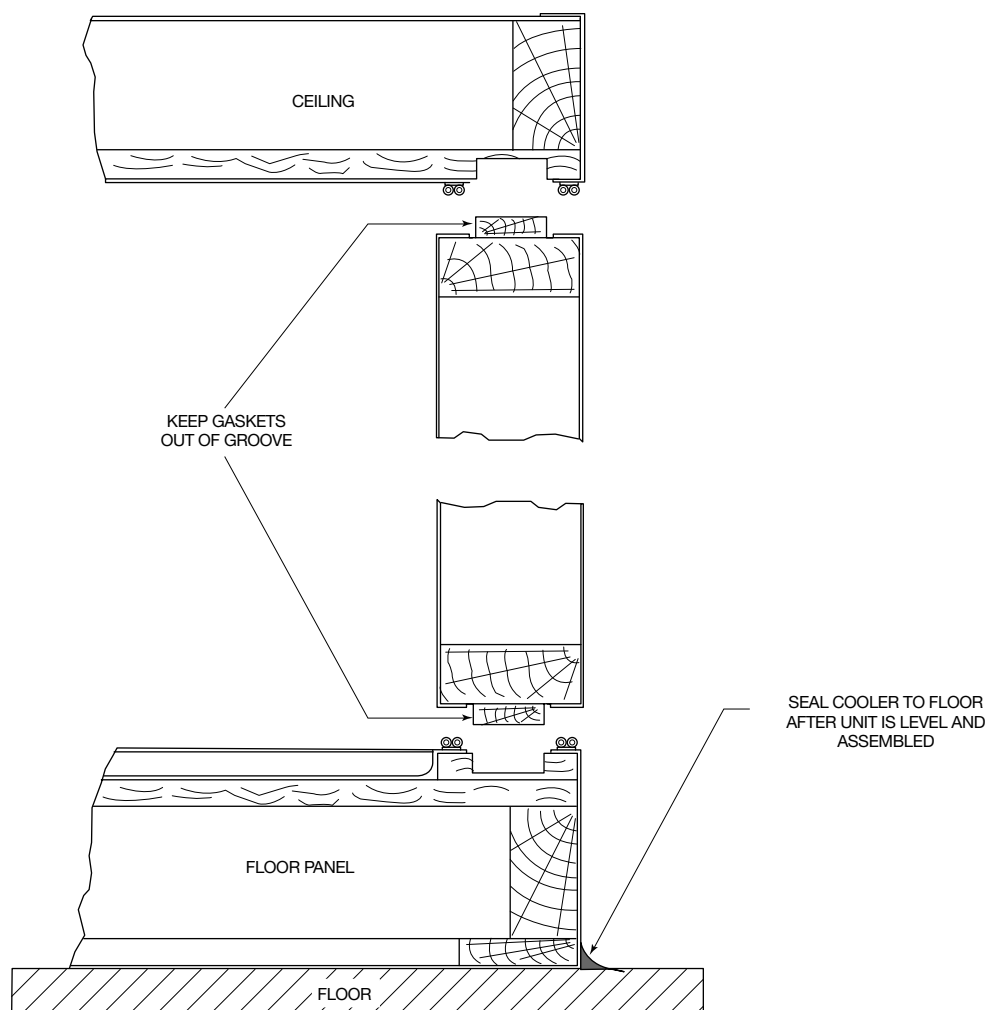

Four Keg Cooler

Four Keg Cooler Assembly

Assemble panels as follows:

Section 1:..... Floor

Section 2:..... Left Wall

Section 3:..... Left Back Wall

Section 4:..... Right Back Wall

Section 6:..... Front with Door

Section 5:..... Right Wall

Section 7:..... Ceiling

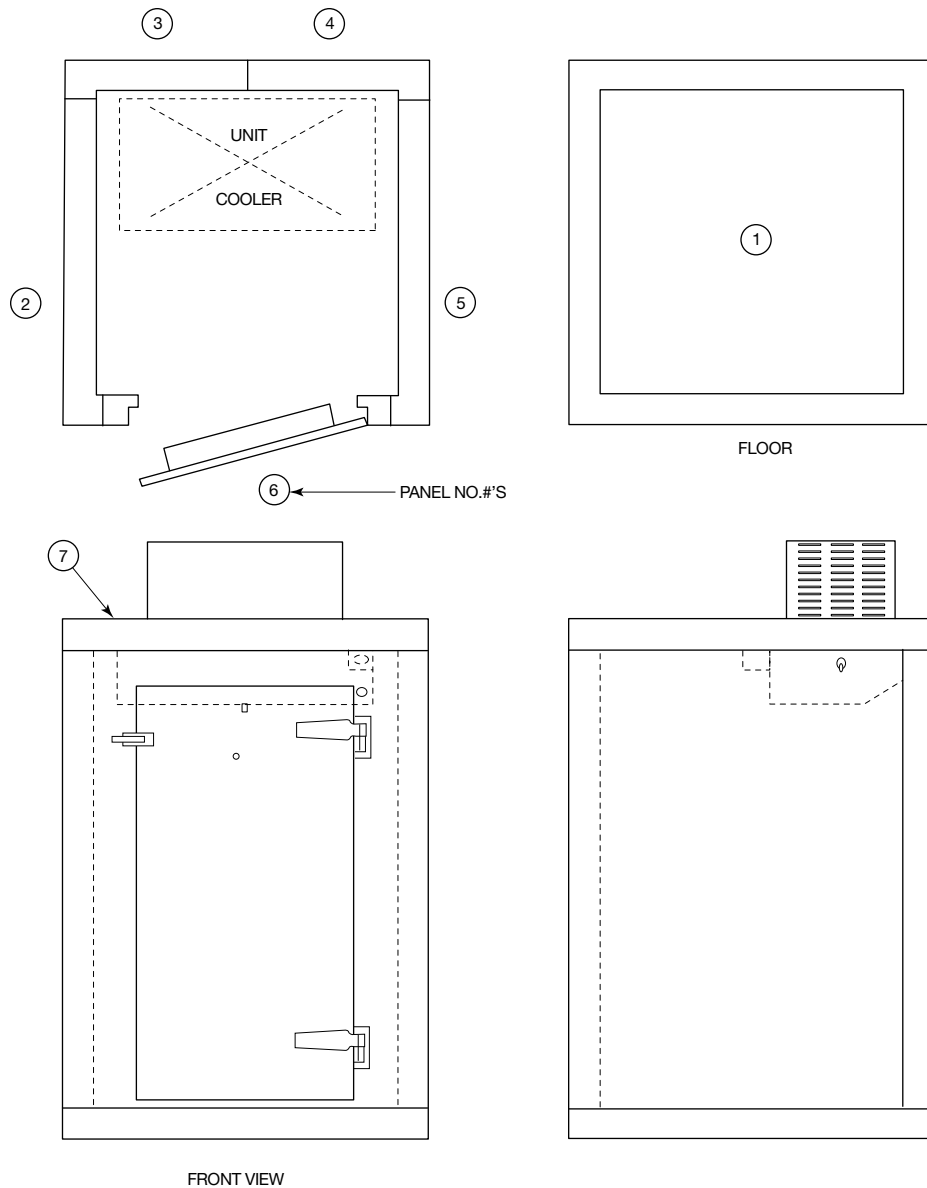

Ten Keg Cooler

Ten Keg Cooler Assembly

Assemble panels as follows:

Section 1 & 2: Floor-Section

Section 3: Left Wall

Section 4: Left Back Wall

Section 5: Right Back Wall

Section 3A: Right Wall

Section 6: Right Front Wall

Section 7: Door Section

Section 8: Left Front Panel

Section 9: Ceiling Panel with
Evaporator Housing

Section 10: Ceiling Panel

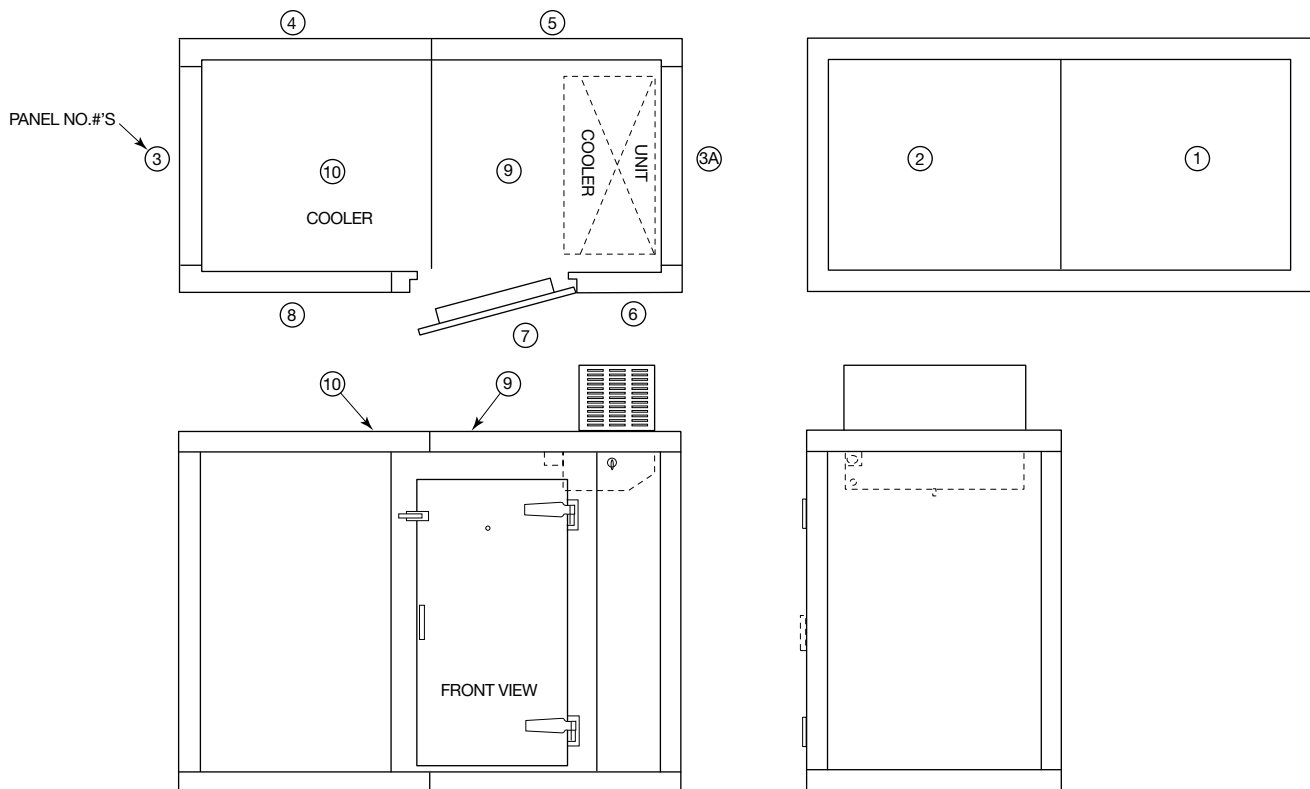

Perlick is committed to continuous improvement. Therefore, we reserve the right to change specifications without prior notice.

General Information

Electrical Requirements

The package unit must be installed so that the wiring conforms to, and is in accordance with National and Local Electrical Codes. (See Condensing Unit Data Plate for Electrical Specifications.)

CAUTION: Do not attempt to operate the condensing unit on any other power source than that listed on the unit data plate. See appropriate wiring diagram on pages 9, 10 or 11.

Starting The Cooler

Allow the empty utility cooler to operate 24 hours for a settling-out period before use.

Temperature Control

The temperature control is located on the evaporator housing. It is factory adjusted to maintain a temperature of approximately 34° F. cut out and 40° F. cut in. Cut out temperatures lower than 34°F. are not advisable as excessive frost may accumulate on the evaporator.

If excessive frost does accumulate, the unit is operating at too cold a temperature. To defrost the evaporator, turn off the electrical power to the condensing unit or turn the control to a warmer position to allow the fan motor to defrost it. The control should then be reset to a temperature that will not ice up the evaporator. A plastic drain hose should be attached to the drain pan of the evaporator and routed through the wall panel. A receptacle should be provided for accumulated condensing water or connect to a building drain facility.

Ventilation Requirements

Air-cooled units must be furnished with sufficient ventilation to maintain their efficiency. The table at right indicates the minimum room size/cubic footage, only the space above the condensing unit can be used. When the room size is below minimum, some type of forced ventilation must be provided.

There should be nothing on or around the machinery compartment area which will restrict the flow of room temperature air to the condenser or over the compressor.

Compressor H.P.	Natural Circulation Cu. Ft. Room Volume Needed	Forced Air Circulation C.F.M. Fresh Air Entering Room
1/3 to 1/2	600	220

Cleaning the Condensing Unit

Inspect the machinery compartment every 60 days. A heavy accumulation of dirt and/or grease on the front of the condensing unit (radiator) must be cleaned off with a stiff brush or vacuum cleaner. Be careful not to bend the aluminum fins on the condensing unit.

Warranty

This Utility Cooler is fully warranted against defects in both material and workmanship for a period of one (1) year from date of sale. Defective parts must be returned to Perlick freight prepaid. All parts found to be defective upon inspection will be replaced on a no-charge basis, F.O.B. our factory. Perlick is not responsible for parts damaged by alteration, unauthorized service, accident or abuse. All costs incident to replacement, including labor, refrigerant, and/or loss of sales are incidental to this warranty and must be borne by the user.

Replacement Parts

How to Order Replacement Parts

Contact your local Perlick dealer to order replacement parts.

Be prepared to provide the model and serial number of the cooler. The serial number is printed on a label which is attached to the inside wall, adjacent to the evaporator housing.

SELF-CONTAINED UTILITY COOLERS			
FOUR KEG		TEN KEG	
Description	Part Number	Description	Part Number
Compressor Only	57499	Compressor Only	57860
Condensing Unit Fan Motor	57513	Condensing Unit Fan Motor	C15250A2
Condensing Unit Fan Blade	C3150-3	Condensing Unit Fan Blade	C15250A3
Evaporator Coil Assembly	57861	Evaporator Coil Assembly	57872
Expansion Valve	57877	Expansion Valve	57877
Temp. Control (two-wired)	57891	Temp. Control (two-wired)	57891

ALL MODEL UTILITY COOLERS			
Description	Part Number	Description	Part Number
Switch	57878	Evaporator Fan Guard	57875
Light Bulb	C31358	Plug Button	57882
Bulb Guard	C25969-1	Door Sill	57883
Thermometer	57879	Door Closure	57884
Hinged Door Assy.	57880	Light Indicator	57858
Gasket-Door Assy.	57881	Hinge	57885
Evaporator Fan Motor	57873	Handle	57886
Evaporator Fan Blade	57874	Door Wiper Gasket	57908



Perlick is committed to continuous improvement. Therefore, we reserve the right to change specifications without prior notice.

Wiring Diagram — Four Keg Self-Contained Cooler

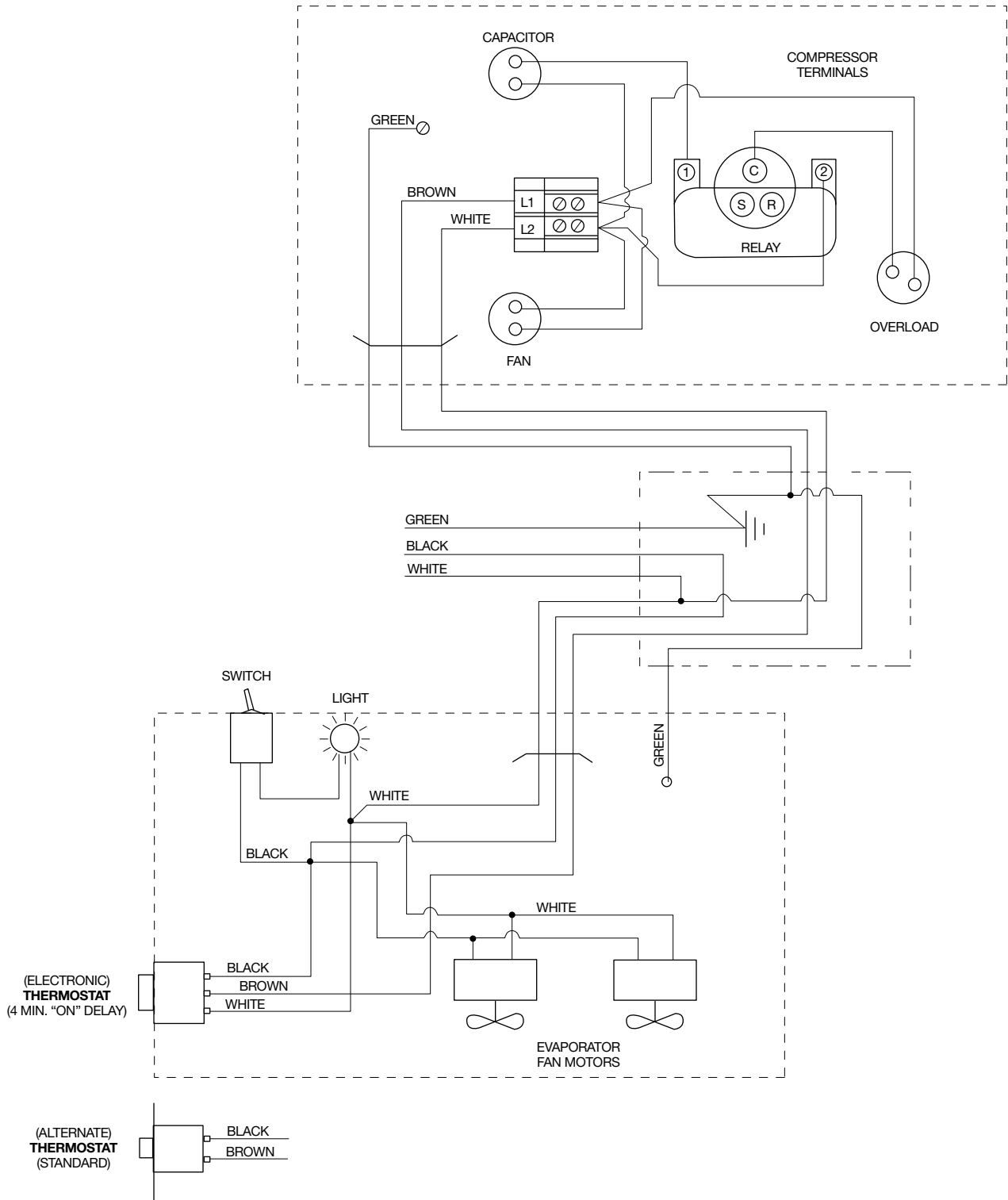

Wiring Diagram — Ten Keg Self-Contained Cooler

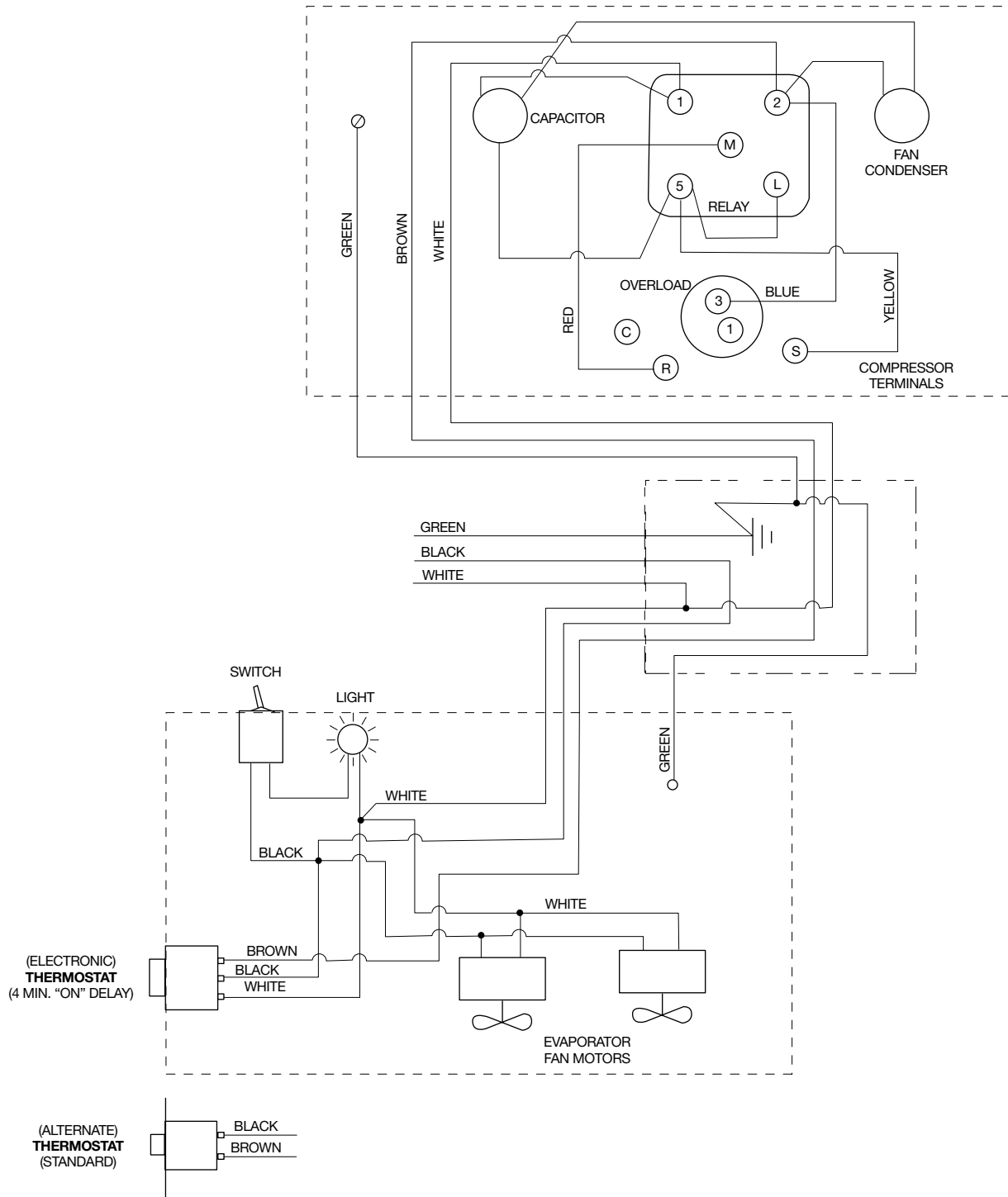

Perlick is committed to continuous improvement. Therefore, we reserve the right to change specifications without prior notice.





8300 West Good Hope Road • Milwaukee, WI 53223 • Phone 414-353-7060 • Fax 414-353-7069
Toll Free 800-558-5592 • E-Mail: Perlick@Perlick.com • www.Perlick.com

Form No. Z2026
Rev 01.28.09

Free Manuals Download Website

<http://myh66.com>

<http://usermanuals.us>

<http://www.somanuals.com>

<http://www.4manuals.cc>

<http://www.manual-lib.com>

<http://www.404manual.com>

<http://www.luxmanual.com>

<http://aubethermostatmanual.com>

Golf course search by state

<http://golfingnear.com>

Email search by domain

<http://emailbydomain.com>

Auto manuals search

<http://auto.somanuals.com>

TV manuals search

<http://tv.somanuals.com>