

INSTALLATION AND OPERATION INSTRUCTIONS

SINGLE DOOR FREEZER

MODEL NOS.

F24N
F24S

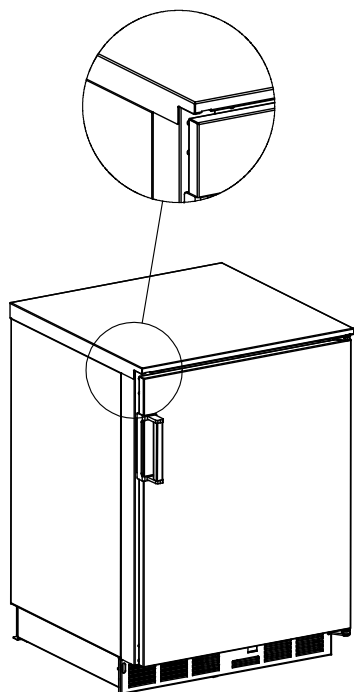

F24S

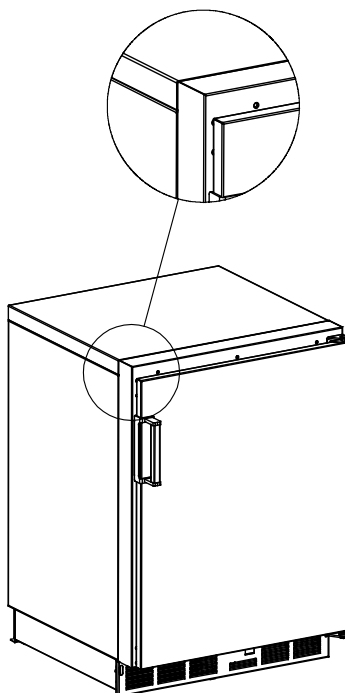

F24N

IMPORTANT INFORMATION

This manual has been prepared to assist you in the installation of your Freezer and to acquaint you with its operation and maintenance.

We dedicate considerable time to ensure that our products provide the highest level of customer satisfaction. If, however service is required, call Perlick at 1-800-777-7267 or your dealer who can provide you with a list of qualified service agents. For your own protection, never return merchandise for credit without our approval.

We thank you for selecting a Perlick product and assure you of our continuing interest in your satisfaction.

IMPORTANT WARRANTY INFORMATION

A Warranty card is enclosed that must be completed and mailed to the Perlick Corporation in order to register the warranty. If the card is not returned to Perlick, the warranty period will begin from the date the equipment is shipped from the factory.

Table of Contents

| | |
|---|-----|
| Cabinet Specifications | 2 |
| Installing | |
| Uncrating and Inspection | 3 |
| Plumbing | 3 |
| Electrical..... | 3 |
| Installing Shelves | 3 |
| Installing Casters or Legs..... | 3 |
| Placing The Cabinet..... | 3 |
| Sealing the Floor..... | 3 |
| Defrost System | 4 |
| Temperature Control | 4 |
| Cleaning..... | 5 |
| Cleaning Stainless Steel/Avoiding Corrosion | 5 |
| Replacement Parts | 6/7 |
| Wiring Diagram | 8 |



8300 West Good Hope Road • Milwaukee, WI 53223 • Phone 414-353-7060 • Fax 414-353-7069
Toll Free 800-558-5592 • E-Mail: Perlick@Perlick.com • www.Perlick.com

Sizes and Specifications

Single Door Freezer

MODEL NUMBERS

| | NO FINISHED TOP | FINISHED TOP |
|----------------------|-----------------|--------------|
| BLACK DOOR | F24NB | F24SB |
| STAINLESS STEEL DOOR | F24NS | F24SS |

SPECIFICATIONS

| | | |
|-----------------------|---|--|
| LENGTH (mm) | 24" (610) | 24" (610) |
| INTERIOR Cu. FT. (m3) | 4.9 (0.14) | 4.9 (0.14) |
| GLASS CAPACITY | 86 Glasses | 86 Glasses |
| CONDENSING UNIT H.P. | 1/5 HP | 1/5 HP |
| AMPS | 2.0 | 2.0 |
| SHIP WT lbs. (kg) | 145 (54) | 145 (54) |
| INTERIOR | Both Models: Inner Liner is stainless steel. Includes two adjustable vinyl coated shelves plus a bottom shelf | |
| EXTERIOR | Back, top, and sides are galvanized steel | Top and sides are 20ga stainless steel Back is galvanized steel |
| | Both models: Front is 20ga stainless steel. Doors are either black powder coat, 20ga CRS or 20ga stainless steel. Bottom is 18ga galvanized steel with 20ga stainless grille | |
| ELECTRICAL | 115V, 60Hz., 1 Phase. Furnished with 6 foot rubber plug-in cord | |
| PLUMBING | None required. Moisture drains to self evaporating condensate pan in machinery compartment | |
| INSULATION | 2 inch foamed-in-place polyurethane insulation | |
| TEMPERATURE RANGE | Adjustable from -10 to +10deg F (-23 to -12deg C) | |
| REFRIGERATION | R134a capillary tube type with hermetic condensing unit. Front access for condenser and cleaning | |
| VENTILATION | Front vented. | |
| DEFROST SYSTEM | Solid-state, push button hot gas defrost system, manually initiated at end of each day, automatically terminates after six hours. Evaporator automatically defrosts every 4 hours for approximately 20 minutes (time/temperature terminated) | |
| OPTIONAL ACCESSORIES | *Set of 4 casters (3 3/4" high) P/N 65426 *Set of 4 adjustable legs (6" - 7 1/4" high) P/N 65423 | |

+Capacity calculations based on use of 3" dia. Glasses on standard shelving.

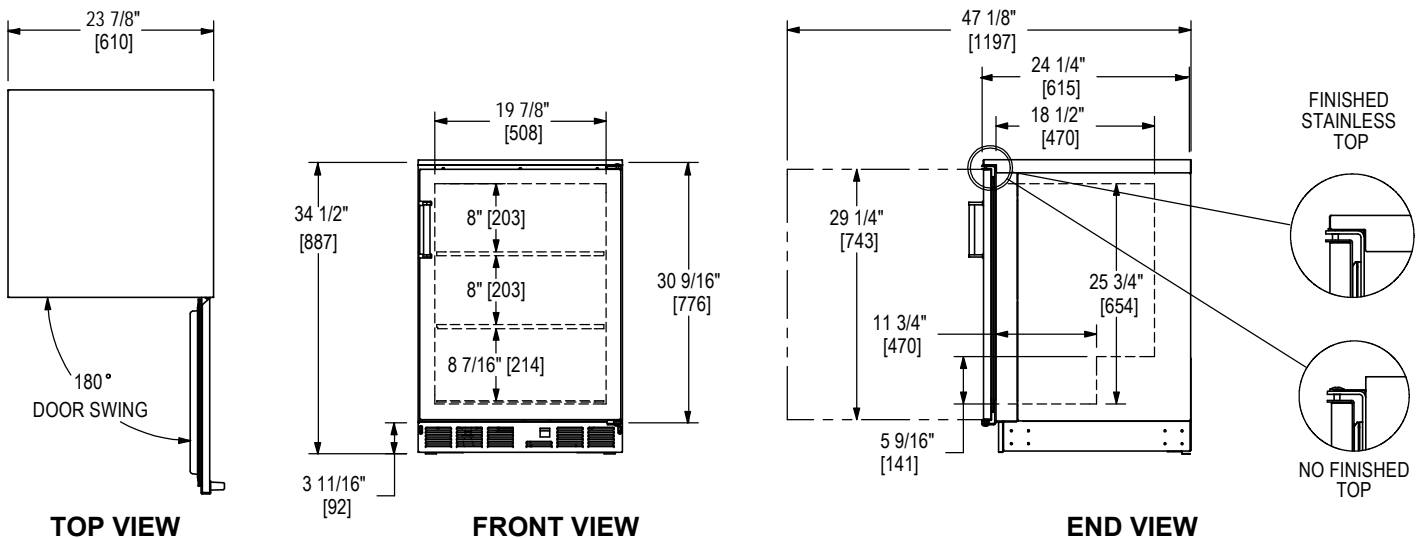
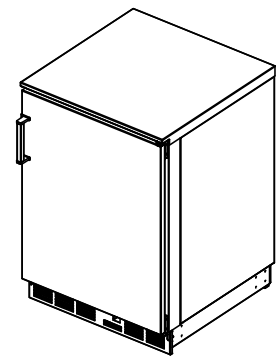

Perlick is committed to continuous improvement. Therefore, we reserve the right to change specifications without prior notice.

Preparing the Cabinet – Single Door Freezer

Uncrating and Inspection

Remove all crating material before operating. Carefully inspect cabinet for hidden damage. If damage is discovered, file your claim immediately with the transport company. Perlick is not responsible for damage in transit.

Plumbing

No plumbing connections are required. Condensate from the cooling coil is automatically evaporated through a condensate pan located in the condensing unit section.

Electrical

The cabinet must be connected to a separately fused power source (see Electrical Specification Plate) and grounded in accordance with National and Local Electrical Codes.
CAUTION: Do not attempt to operate the equipment on any other power source than that listed on the Electrical Specification Plate.

Placing the Cabinet

To assure maximum performance, fresh air must be allowed to circulate through the machinery compartment. Do not place anything in front of the cabinet that would obstruct air flow at these grilles. Do not place the unit in an unventilated small room.

Cabinet should be leveled front to back and side to side.

Installing Casters or Legs (optional)

Attach casters or legs to the mounting bracket with the lockwashers and 1/4-20 hex head nuts provided. Attach bracket and leg/caster assembly to the side of the cabinet base using the 1/4-20 hex head self-tapping machine screws provided.

Anti-tip (without Legs or Casters)

To prevent the cabinet from tipping forward and to provide a stable installation, the cabinet must be secured in place with an anti-tip device.

A set of metal anti-tip brackets and installation screws (#10-3/4" wood screw) are supplied. These brackets should be attached to the floor, at the back of the cabinet; each bracket located to catch each rear leveling leg when the cabinet is pushed backward into position.

THE ANTI-TIP BRACKETS MUST CATCH EACH OF THE LEVELING LEGS TO HAVE A STABLE AND SAFE INSTALLATION.

Some installation sites might need to be modified to provide a secure surface for attaching the bracket. Refer to the illustration below for anti-tip mounting bracket locations.

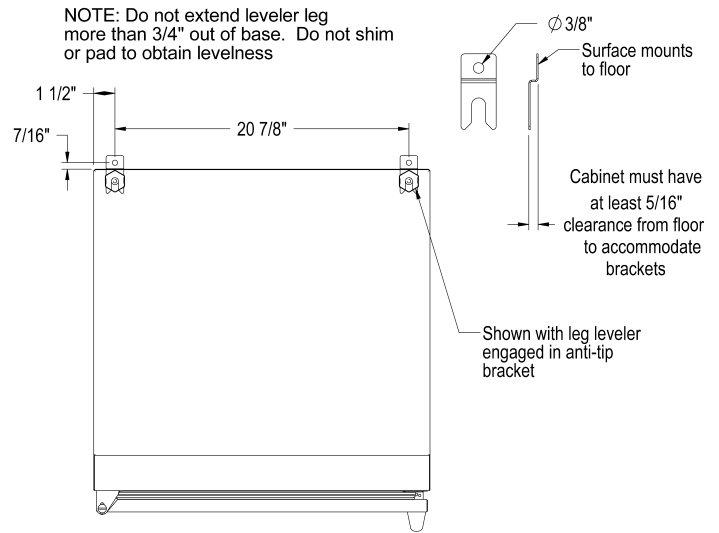

TOP VIEW
SHOWN

Operation Instructions – Single Door Freezer

For sanitation purposes, it may be necessary to seal the base of the cabinet to the floor. This can be accomplished by laying a bead of silicone sealant between the base of the cabinet and the floor as shown by the figure below.

When sealing the cabinet to the floor, make sure that the louvered front grille plate can still be removed for condenser maintenance and cleaning

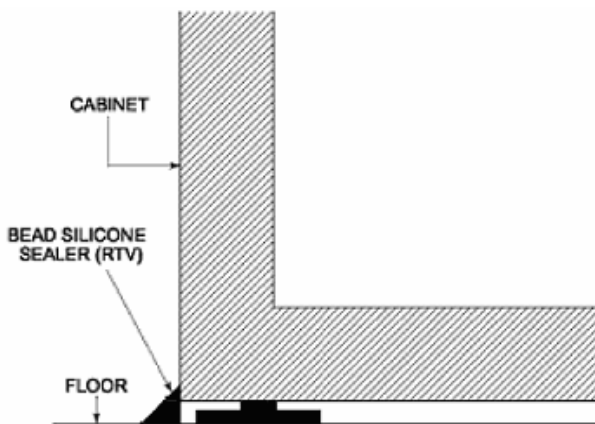

Defrost System - Hot Gas Defrost

This system consists of a six-hour, as well as a four hour cycle which includes a 20 minute evaporator defrost. The six hour defrost cycle is manually activated and automatically terminated, while the four hour cycle is completely automatic.

The Six Hour Solid-State Defrost Timer

This timer shuts off the power to the condensing unit, the evaporator fan, and the automatic four hour defrost timer.

To activate the six hour defrost system, depress the defrost switch located on the front grille of the cabinet. An amber light will illuminate and the defrost cycle will begin. When the defrost cycle ends, the light goes off and the cabinet resumes normal operation. To manually cancel the defrost cycle, momentarily turn off the electricity to the machine.

The Four Hour Defrost Timer

This timer ensures that frost will not buildup on the evaporator coil. Every four hours the hot gas by-pass valve is opened and hot gas is circulated through the evaporator coil. The defrost is terminated when the coil is clear of frost. The defrost cycle lasts for approximately 20 minutes.

During normal operation it is recommended that the doors are not left open to prevent excessive frost buildup on the coil.

Temperature Control

An adjustable temperature control is located inside the freezer on the evaporator fan panel assembly. Approximate temperature operating range: minus 15° F. minimum and plus 10° F. maximum. Make adjustments as shown to attain the desired temperature.

- **Colder Temperatures:** Turn the adjusting screw clockwise (to the right).
- **Warmer Temperatures:** Turn the adjusting screw counterclockwise (to the left).
- **Temperature Control "OFF":** Turn the adjusting screw completely counterclockwise to the "O" position until a click is noted.

The condenser fan and the evaporator fan motor turns off and on with the compressor.

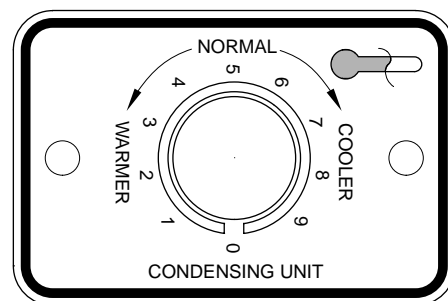

Perlick is committed to continuous improvement. Therefore, we reserve the right to change specifications without prior notice.

Cleaning Instructions – Single Door Freezer

Cleaning the Condenser:

- The condenser (located behind the front grille) should be inspected every 30 days, and cleaned, if necessary. Failure to keep the condenser clean will cause a loss in condensing unit efficiency, or compressor failure.

Cleaning the Cabinet:

- Use a damp cloth with a mild detergent and water to clean the inside and outside of the cabinet. Dry thoroughly. Do not allow cleaning agents or large amounts of water to go down the drain. Use an acceptable stainless steel polish to clean all stainless steel surfaces. Never use steel wool or scouring pads to clean stainless steel.

Avoiding Stainless Steel Corrosion

Corrosion can be prevented by following product cautions, cleaning instructions and avoiding use of certain chemicals or objects which will cause stainless steel corrosion.

STAINLESS STEEL ENEMY

- Steel wool or steel scouring pads
- Cherry/Orange/Olive juice
- Chlorine Bleach
- Sharp Objects

Replacement Parts – Single Door Freezer

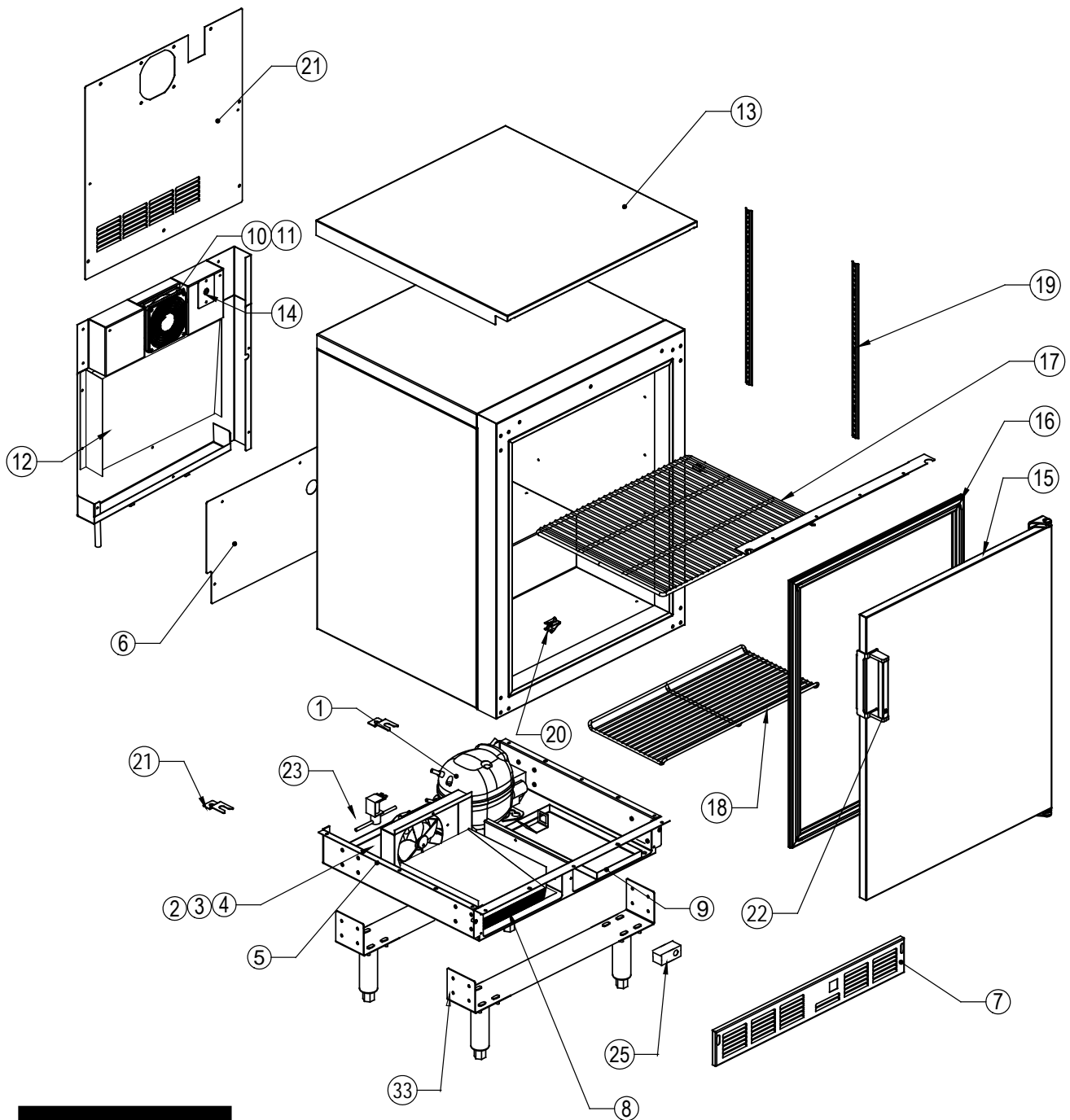

CAUTION

- Service should be done by a qualified refrigeration technician
- Disconnect all power before servicing the cabinet



Perlick is committed to continuous improvement. Therefore, we reserve the right to change specifications without prior notice.

Replacement Parts – Single Door Freezer

| MODEL NOS. | | All Models |
|------------|---|------------|
| ITEM | Description | Part #'s |
| 1 | Compressor for R134A | 63779 |
| 2 | Condenser Fan Motor | C15239A |
| 3 | Condenser Fan Motor Bracket | 60988-1 |
| 4 | Condenser Fan Blade | C22370 |
| 5 | Condenser Fan Shroud | 65206-2 |
| 6 | Rear Panel | 65159-1 |
| 7 | Front Grille | 65158-2 |
| 8 | Condenser Coil | 65252 |
| 9 | Condensate Pan | 65473 |
| 10 | Evaporator Fan Guard | 65254 |
| 11 | Evaporator Fan Motor | 65253 |
| 12 | Evaporator Assembly | H66136F |
| 13 | Top Overlay | 65429-1SS |
| 14 | Temperature Control w/ Dial Plate | 61282 |
| 15 | Door Assembly | 66223 |
| 16 | Magnetic Door Gasket | 66019 |
| 17 | Shelf | 66236-1 |
| 18 | Shelf, Bottom | 64809-1 |
| 19 | Pilaster | C19271 |
| 20 | Shelf Clip | C15875 |
| 21 | Evaporator Grille | 66139-2 |
| 22 | Tip Over Bracket | 63740 |
| 23 | Door Handle | C31409-1 |
| 24 | Bypass Valve/Solenoid Assem. | 63717 |
| 25 | Defrost Switch (Not shown) | C31659 |
| 26 | Solid State Controller (Not shown) | 57466 |
| 27 | Time Delay Relay (Not shown) | 63794 |
| 28 | Defrost Terminator (Not shown) | 57676 |
| 29 | Power Cord Wiring Harness (Not shown) | 65470 |
| 30 | Evap Assy Wiring Harness (Not shown) | 65475 |
| 31 | Relay Wiring Harness (Not shown) | 65476 |
| 32 | 6 Hr Defrost Wiring Harness (Not shown) | 61959 |
| 33 | Leg Kit set of 4 Includ. Bkts. | 65423 |
| 34 | Caster Kit set of 4 Includ. Bkts. (Not shown) | 65426 |
| 35 | Complete Hinge Set-Left | 66264L |
| 36 | Complete Hinge Set-Right | 66264R |

Wiring Diagram – Single Door Freezer

WIRING DIAGRAM FOR ONE DOOR FREEZER WITH HOT GAS DEFOST

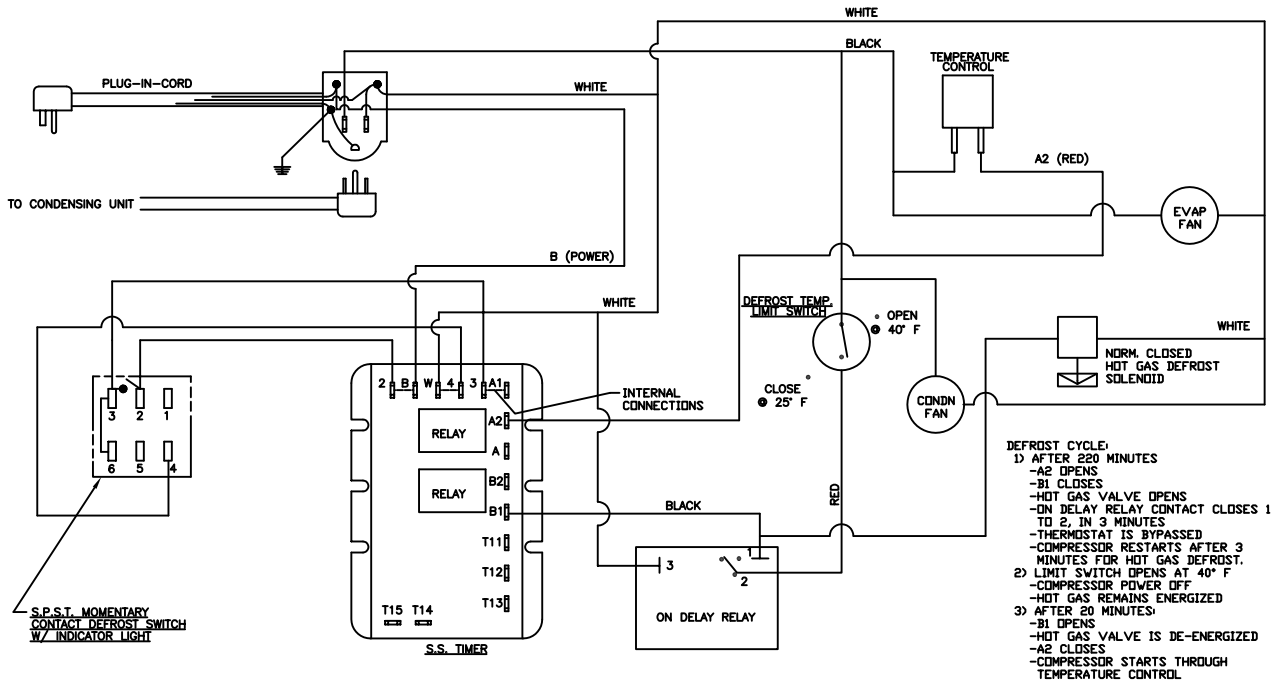

8300 West Good Hope Road • Milwaukee, WI 53223 • Phone 414-353-7060 • Fax 414-353-7069
 Toll Free 800-558-5592 • E-Mail: Perlick@Perlick.com • www.Perlick.com

Perlick is committed to continuous improvement. Therefore, we reserve the right to change specifications without prior notice.

Form No. Z2255
 Rev. 4.19.05

Free Manuals Download Website

<http://myh66.com>

<http://usermanuals.us>

<http://www.somanuals.com>

<http://www.4manuals.cc>

<http://www.manual-lib.com>

<http://www.404manual.com>

<http://www.luxmanual.com>

<http://aubethermostatmanual.com>

Golf course search by state

<http://golfingnear.com>

Email search by domain

<http://emailbydomain.com>

Auto manuals search

<http://auto.somanuals.com>

TV manuals search

<http://tv.somanuals.com>