

BEER LINE MAINTENANCE SYSTEM

**The best way to keep
beer lines clean**

MODEL NOS.
BLM 2000

**Technology that's revolutionizing
beer line cleaning.**

- Operates 24 hours a day/7 days a week keeping beer lines clean.
- Reduces cleaning cycle from 26 to 6 times per year.
- A single transponder covers 150 feet of line.
- Quick and easy to install. Takes only minutes per line.
- Brewery-fresh taste that lasts from cleaning to cleaning.
- Three-year limited manufacturer's replacement warranty.



Systems and products for the foodservice and brewing industries since 1917

Beer Line Maintenance System

Perlick Beer Line Maintenance System Component Specifications and Description

HOW IT WORKS:

The BLM2000 control unit generates a complex audio signal. It transports this signal through the beer lines via transponders that are attached to each beer line. The signal creates an unfriendly environment for yeast and bacteria cells to grow. The prevention of yeast and bacteria contamination allows beer to flow from keg to glass without any deterioration in quality.

Power Adapter	Converts standard electricity 220 Volts AC (VAC) or 110 VAC to 16 VAC. Operating voltage: 16 volts AC. "Daisy-chain" up to 10 Control Units with one power adapter. Grounded Adapter Weight: 1.03 lbs. (467 g.)
Control Unit	Converts the 16 VAC signal to a composite frequency electric signal. Amps: 50 milliamps Contains: control unit, instruction manual, double-sided tape, wall bracket, screw kit and warranty card. Weight: .287 lbs. (130 g.)
Transponder	Converts the composite frequency electrical signal to an audio signal. Single transponder weight: .154 lbs. (70 g.) Double transponder weight: .21 lbs. (95 g.)
Power Connect Cable	A 3¼ foot (1 m.) cable with male connector on both ends. Used to connect two control units together.
Power Extension Cable	A 16½ foot (5 m.) cable with a male connector on one end and a female connector on the other. Used to extend the cable of a power adapter or extend a power connect cable.
Recommended Cleaning Cycle	Chemically clean lines every eight weeks. Faucets disassembled and cleaned every four weeks.

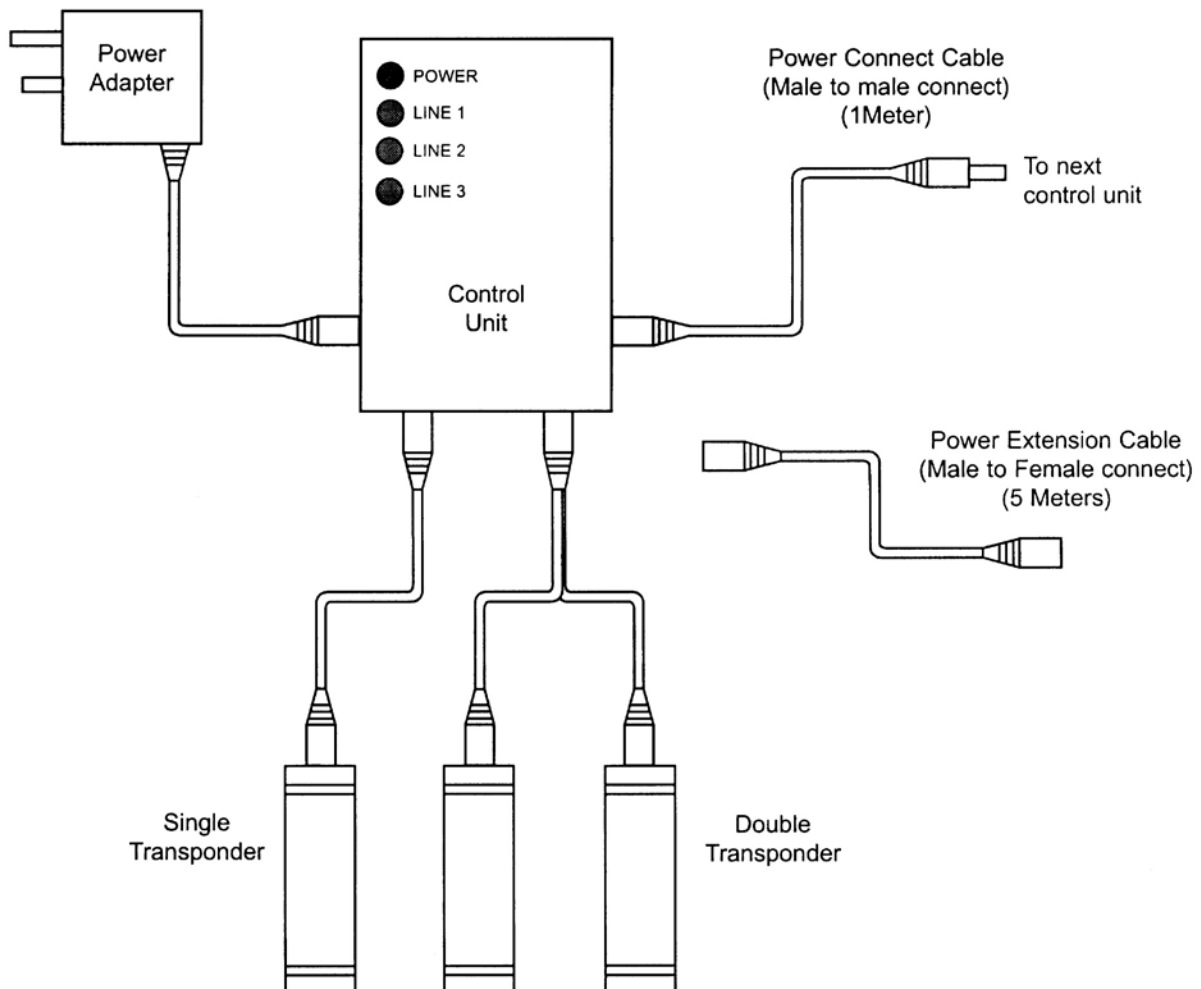

8300 West Good Hope Road • Milwaukee, WI 53223 • Phone 414-353-7060 • Fax 414-353-7069
E-Mail: Perlick@Perlick.com • www.Perlick.com

Free Manuals Download Website

<http://myh66.com>

<http://usermanuals.us>

<http://www.somanuals.com>

<http://www.4manuals.cc>

<http://www.manual-lib.com>

<http://www.404manual.com>

<http://www.luxmanual.com>

<http://aubethermostatmanual.com>

Golf course search by state

<http://golfingnear.com>

Email search by domain

<http://emailbydomain.com>

Auto manuals search

<http://auto.somanuals.com>

TV manuals search

<http://tv.somanuals.com>