

Digital Surround Receiver DFR9000

Instructions for Use
English 4



PHILIPS

Important notes for users in the U.K.

Mains plug

This apparatus is fitted with an approved 13 Amp plug. To change a fuse in this type of plug proceed as follows:

- 1 Remove fuse cover and fuse.
- 2 Fix new fuse which should be a BS1362 5 Amp, A.S.T.A. or BSI approved type.
- 3 Refit the fuse cover.

If the fitted plug is not suitable for your socket outlets, it should be cut off and an appropriate plug fitted in its place. If the mains plug contains a fuse, this should have a value of 5 Amp. If a plug without a fuse is used, the fuse at the distribution board should not be greater than 5 Amp.

Note: The severed plug must be disposed of to avoid a possible shock hazard if it is inserted into a 13 Amp socket elsewhere.

How to connect a plug

The wires in the mains lead are coloured with the following code: blue = neutral (N), brown = live (L).

As these colours may not correspond with the colour markings identifying the terminals in your plug, proceed as follows:

- Connect the blue wire to the terminal marked N or coloured black.
- Connect the brown wire to the terminal marked L or coloured red.
- Do not connect either wire to the earth terminal in the plug, marked E (or e) or coloured green (or green and yellow).

Before replacing the plug cover, make certain that the cord grip is clamped over the sheath of the lead - not simply over the two wires.

Copyright in the U.K.

Recording and playback of material may require consent. See Copyright Act 1956 and The Performer's Protection Acts 1958 to 1972.



This product is equipped with copy protection technology required by many motion picture companies that produce high definition movies. Consumers should note that not all high definition television sets are fully compatible with the applied technology and therefore may cause artifacts to be displayed in the picture. In case of 525 or 625 Progressive Scan picture problems, it is recommended that the user switches the connection to the 'standard definition' output.

Copyright protection

This product incorporates copyright protection technology that is protected by U.S. patents and other intellectual property rights. Use of this copyright protection technology must be authorised by Macrovision, and is intended for home and other limited viewing uses only unless otherwise authorised by Macrovision. Reverse engineering or disassembly is prohibited.

Recording is permissible insofar as copyright or other rights of third parties are not infringed upon.

Environmental information

All redundant packing material has been omitted. We have done our utmost to make the packaging easily separable into three mono materials:  cardboard (box),  polystyrene foam (buffer) and  polyethylene (bags, protective foam sheet).

Your set consists of materials which can be recycled if disassembled by a specialized company. Please observe the local regulations regarding the disposal of packing materials, exhausted batteries and old equipment.

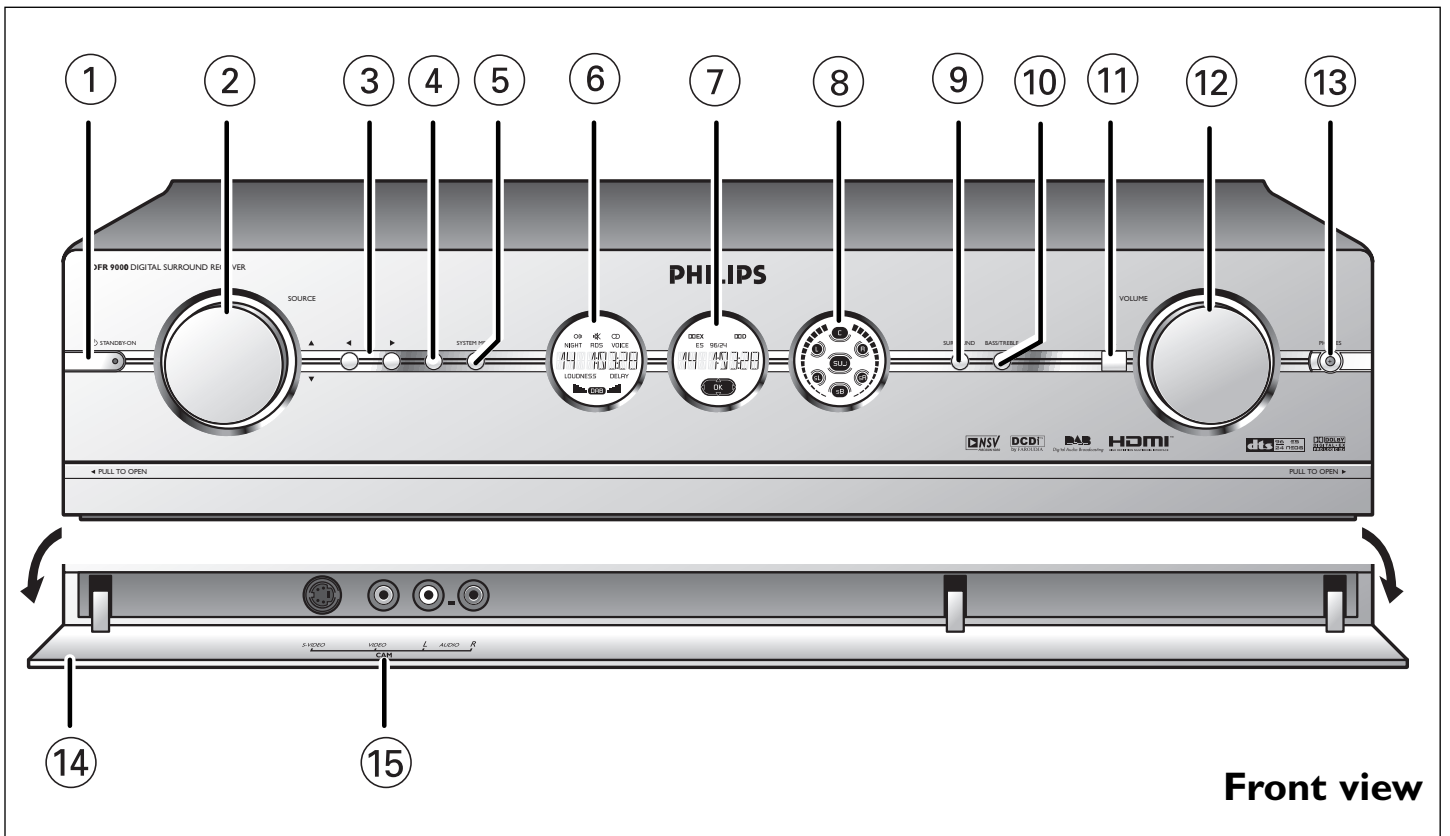

Front view

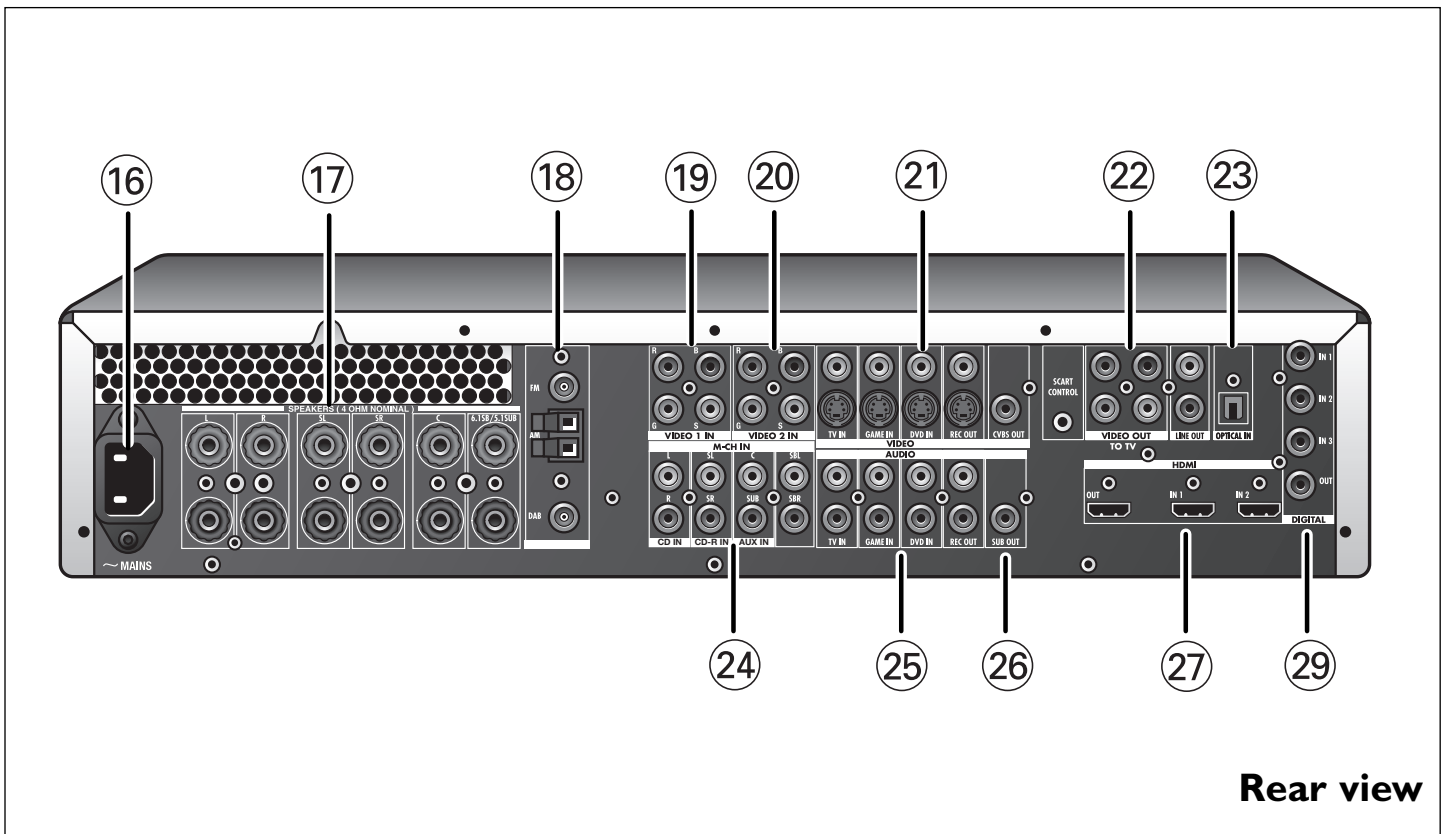

Rear view

Index

1. Important information	6
2. Introduction	7-8
Packaging contents.....	8
3. Functional overview	9-13
3.1 Front view	9
3.2 Rear view.....	10-11
3.3 Remote control.....	11-12
3.4 Displays	13
4. Installation	14-23
4.1 General remarks.....	14
4.2 Connecting to your TV.....	14-15
4.3 Connecting analogue audio equipment.....	15-16
4.4 Connecting digital audio equipment.....	16
4.5 Connecting analogue multi-channel equipment.....	17
4.6 Connecting digital HDMI equipment	18
4.7 Connecting video equipment.....	18-20
4.8 Connecting speakers.....	20-21
4.9 Positioning the speakers.....	21-22
4.10 Connecting antennas.....	22
4.11 Connecting a video camera	23
4.12 Connecting headphones	23
4.13 Installing the batteries in the remote control.....	23
4.14 Connecting to the mains	23
5. System menu	24
5.1 Basic menu navigation.....	24
6. Setting up the receiver	25-26
6.1 Positioning your DFR9000	25
6.2 Switching on and off.....	25
6.3 Selecting your system menu language	25
6.4 Setting the speaker size and distance	25-26
6.5 Setting the speaker volume.....	26
6.6 Reassigning input sockets.....	26
7. Operating the amplifier.....	27-28
7.1 Source selection.....	27
7.2 Sound control.....	27
7.3 Selecting surround modes	27
7.4 Playing sources.....	28
7.5 Recording from sources.....	28
7.6 Recording from the digital input	28
8. Operating the tuner.....	29-31
8.1 Tuning to radio stations (FM, FM-M and MW band).....	29
8.2 Preset radio stations (FM, FM-M and MW band).....	29-30
8.3 DAB radio stations.....	30-31
9. Surround modes	32

10. System menu overview33-39
 10.1 Configuration menu.....33-34
 10.2 Balance menu.....34
 10.3 Speakers menu34-35
 10.4 Tuner menu35
 10.5 Picture menu.....36
 10.6 Enhancement menu.....36-37
 10.7 AV input menu.....37-38
 10.8 Gain menu.....39

11. Troubleshooting.....40-42

12. Glossary.....43-45

13. Technical specifications.....46-47

Helpline49

Warranty50

1. Important information

- Please install and connect the product in the order described in this manual only. This assures best installation results with the least technical hassles.
- Please read this guide carefully before using your DFR9000 and keep it for future reference.
- During set-up and installation, it may be helpful to have the instructions for your audio system, TV or other components at hand.

Safety Precautions

- NEVER MAKE OR CHANGE CONNECTIONS WITH THE POWER OF YOUR AUDIO SYSTEM SWITCHED ON OR YOUR DFR9000 CONNECTED TO THE MAINS.
- Before operating the set, check that the operating voltage indicated on the type plate on the bottom of your set is identical with the voltage of your local mains supply. If not, please consult your dealer.
- The set should not be exposed to dripping or splashing.
No object filled with liquids, such as vases, should be placed on the product.



- Do not expose the set to excessive moisture, rain, sand or heat sources caused by heating equipment or direct sunlight.
- Allow a sufficient amount of free space all around your DFR9000 for adequate ventilation.
- Do not open the set. Contact your Philips retailer if you experience technical difficulties.
- Place the set on a flat, hard and stable surface. When the set is switched to standby mode, it is still consuming some power. To disconnect the set from the power supply completely, remove the AC power plug from the wall socket.
- Do not place the unit directly on a carpeted surface.
- To prevent your DFR9000 from overheating internally, make sure the air around your DFR9000 can circulate. Also, avoid putting any heat sources (e.g. a DVD player) underneath.
- To prevent your DFR9000 from overheating internally, never place anything on top of it.
- Do not use extension leads. To avoid safety hazards, use only the mains lead supplied with your set.
- Do not run mains leads under rugs or carpets or place heavy objects on them.
- Damaged mains leads should be replaced immediately by a mains lead meeting factory specifications.
- When disconnecting the mains lead from the wall socket, always pull on the plug; never pull on the lead.
- If you do not intend to use the set for any considerable length of time, disconnect the plug from the wall socket.
- Before moving the set, be certain to disconnect any interconnection leads with other components, and make certain that you disconnect the set from the wall socket.

Note: To avoid overheating of the set, a safety circuit has been built in. The set will turn down the volume or switch off sound completely if it becomes too hot. If this happens, wait until the set has cooled down.

This set complies with the radio interference requirements of the European Community.

2. Introduction

DFR9000

Congratulations on your purchase of one of the most sophisticated and reliable products on the market today. Your DFR9000 is a high-definition multimedia interface A/V receiver. Not only is your DFR9000 an excellent audio receiver with extremely clear sound, it also provides an HDMI interface for delivering excellent digital picture quality from source components to your TV or monitor screen. Your DFR9000 combines FM and DAB, giving the widest of listening options, as well as improved clarity of sound and more stations. We are sure that, used properly, it will bring you years of enjoyment. Please read this manual carefully before using your DFR9000 and keep it for future reference, as it is a convenient source of information about your DFR9000.

DFR9000 features

Dolby Digital EX and DTS ES

Dolby Digital EX and DTS ES are 6.1-channel formats, with the rear surround audio channel discretely encoded into the Dolby Digital and DTS bit-stream. The formats offer enhanced spatialization over the surround channels for complete 360° sound localization.

HDMI Digital AV connection

HDMI stands for High Definition Multimedia Interface. It is a direct connection that can carry digital HD video as well as digital multi-channel audio. By eliminating the conversion to analogue signals it delivers perfect picture and sound quality.

Digital Audio Broadcasting

Digital Audio Broadcasting (DAB) is the latest in digital radio technology. It allows you to enjoy your favorite radio stations in crystal clear, near CD-quality sound. What's more, you get an even wider choice of radio stations.

NSV™ Precision Video

NSV™ Precision Video is an embedded noise reduction technology that eliminates existing noise inherent in video signals, thereby providing a more refined picture viewing experience.

Video Upscaling

With Video Upscaling you can increase the resolution of SD (Standard Definition) video signals that DVD uses to HD (High Definition) so you will be able to see more details thanks to a sharper, more true-to-life picture.

UCD Digital Amplifier

The UCD Audiphile Digital Amplifier is a full digital Class D amplifier designed to give the lowest output impedance and the best audio performance and efficiency.

Trademark acknowledgment

HDMI, the HDMI logo and High-Definition-Multimedia Interface are trademarks or registered trademarks of HDMI Licensing LLC.

Noise Shaped Video is a trademark of Analog Devices Inc.

Packaging contents

Please check whether the following items are present in the box of the Digital Surround Receiver. They are provided to help you set up and use your DFR9000.

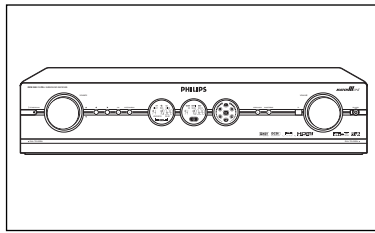

DFR9000

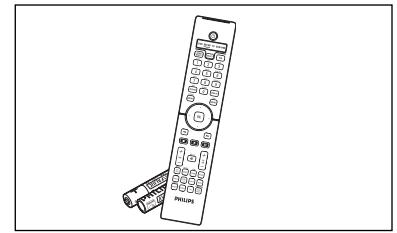

Remote control (including batteries)

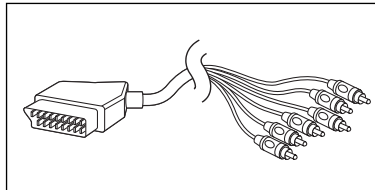

6-cinch to Scart cable

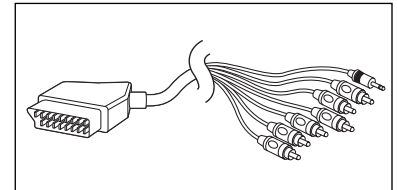

6-cinch + Scart control to Scart cable

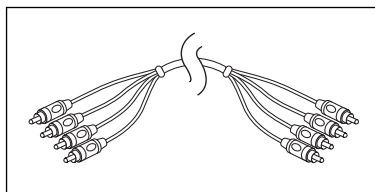

4-cinch audio cable (2x)

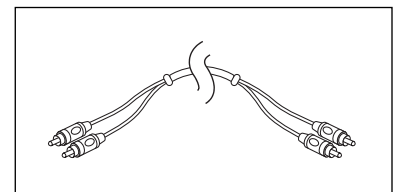

2-cinch audio cable

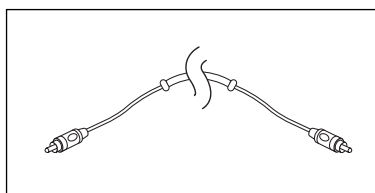

Digital cinch (coaxial) cable

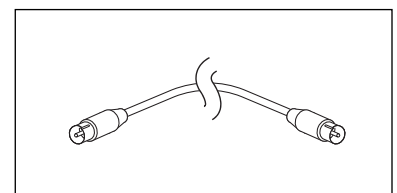

FM antenna cable

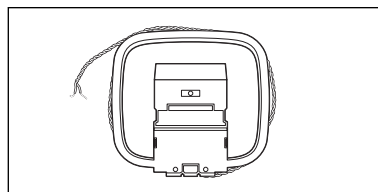

AM antenna

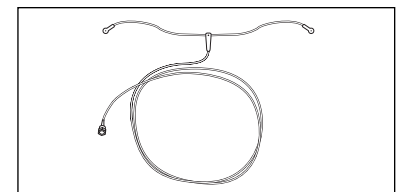

DAB antenna

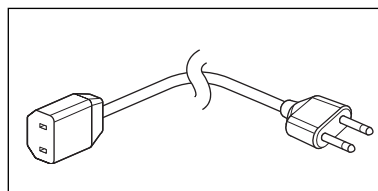

Mains lead Europe

OR

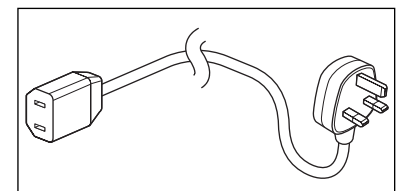

Mains lead U.K.

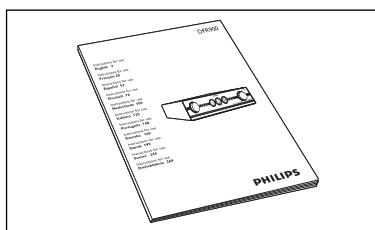

Instructions for Use

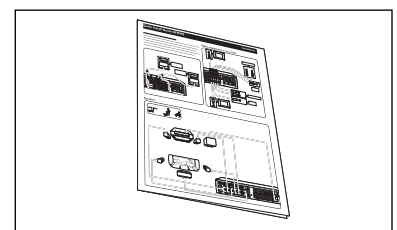

Quick Install Guide

3. Functional overview

Legend of illustrations on inside flap.

3.1 Front view

1 **STANDBY-ON**

Switches the DFR9000 on and to standby.

Standby/On indicator (indicator in the Power/standby button)

- Lights up red when your DFR9000 is connected to the mains and when it is switched off (to Standby).
- Goes out when your DFR9000 is switched on.

2 **SOURCE**

Selects the various connected sources in amplifier mode.

▲▼

- Navigates in up (▲) and down (▼) direction in the menu.
- Select previous (▼) and next (▲) radio stations in TUNER or DAB mode.

3 **◀▶**

- Navigates in left (◀) and right (▶) direction in the menu.
- Selects next (▶) or previous (◀) preset station in TUNER and DAB mode.

4 **OK**

- Confirms actions in the menu.
- Selects secondary audio services in DAB mode.

5 **SYSTEM MENU**

Opens and closes the system menu.

6 **Left display**

- Indicates the present status of the DFR9000.
- Indicates signal strength in DAB mode.
- Indicates the present source.

7 **Centre display**

Informs you on the present status of your DFR9000, selected surround modes and displays the system menu, submenus and menu settings.

8 **Right display**

- Shows which speakers are active.
- Indicates volume level.

9 **SURROUND**

Selects the various available surround modes. Availability of surround modes depends on speaker setup and type of input signal.

10 **BASS / TREBLE**

Enables the VOLUME control to adjust the low (Bass) and high (Treble) frequency response for all channels.

11 **IR**

Receives the signals from the remote control.

12 **VOLUME**

Controls the output level of all audio channels.

13 **PHONES**

Outputs audio signals when listening with headphones.

14 **Flap**

Covers the audio and video input sockets on the front of the DFR9000.

15 **CAM**

Inputs audio and video signals from a portable external source, e.g. a video camera.

3.2 Rear view

Note: Most of the input connectors at the rear of your DFR9000 are assigned for connecting to a specific audio/video playback/recording device. These connectors can be reassigned in the system menu. For this see '6.7 Reassigning input sockets' and '10.7 A/V input menu'.

16 MAINS

Mains inlet socket.

17 SPEAKERS (4 OHM NOMINAL)

Speaker connection panel for connecting:

L/R - Left (L) and right (R) front speakers;

SL/SR - Surround left (SL) and surround right (SR) speakers;

C - Centre speaker.

6.1SB/5.1SUB - Surround back speaker: To be connected in a 6.1 speaker configuration. If no surround back speaker is connected (5.1 or less speaker configuration), these sockets can be used for connecting a passive subwoofer.

18 ANTENNA

FM-, AM- and DAB antenna connectors.

19 VIDEO 1 IN (R, G, B, S)

RGBS video input sockets for connection to the SCART connector of a DVD player/recorder using the 6-cinch to Scart cable supplied.

These sockets can be reassigned for connection to other video equipment.

20 VIDEO 2 IN (R, G, B, S)

RGBS video input sockets for connection to the SCART connector of a satellite receiver; using the 6-cinch to Scart cable supplied.

These sockets can be reassigned for connection to other video equipment.

21 VIDEO

TV IN / GAME IN / DVD IN

CVBS (upper row) and S-Video (lower row) video input sockets for connecting to the CVBS or S-Video output sockets of a TV, game console or DVD player/recorder.

These sockets can be reassigned for connection to other video equipment.

REC OUT

CVBS (upper socket) and S-Video (lower socket) video output sockets for connecting to the CVBS or S-Video input sockets of a DVD recorder or VCR.

CVBS OUT

CVBS output socket for connection to a TV with a CVBS input socket.

22 TO TV

These output sockets are used for connecting your DFR9000 to the Scart connector of your TV, using the 6-cinch + Scart control to Scart cable.

SCART CONTROL

For inserting the 2.5mm jack. When your DFR9000 is activated, Scart control will automatically switch your TV to the correct (active) input source (provided that a Scart connection has been made). The active source will be shown on the TV screen.

VIDEO OUT

RGBS output sockets for inserting the four video cinch connectors.

These sockets can also be connected to the RGB input sockets of a TV.

LINE OUT

Audio output sockets for inserting the two audio cinch connectors.

23 OPTICAL IN

Audio input socket for connection to the digital (optical) audio output socket of a satellite receiver. This socket can be reassigned for connection to other digital equipment (e.g. a CD player; DVD player or CD recorder).

24 M-CH IN

Audio input sockets for connection to the multichannel audio output sockets of multichannel equipment. These sockets are assigned for connection to a SACD player. If no multichannel equipment is available the L/R, SL/SR and C/SUB sockets can be reassigned for connection to analog audio equipment (CD IN, CD-R IN and AUX IN). The SBL/SBR sockets has no function when no multichannel equipment is connected.

25 AUDIO - TV IN / GAME IN / DVD IN

Stereo audio input sockets for connection to the audio output sockets of a TV, game console or DVD player. If one of these sockets is connected to a recording device, this socket needs to be selected in the 'Configuration' menu (submenu 'Rec audio').

AUDIO - REC OUT

Stereo audio output sockets for connecting to the audio input sockets of a DVD recorder or VCR.

26 SUB OUT

Output socket for connecting to an active subwoofer.

27 HDMI - OUT

Output socket for connection to a TV with an HDMI input socket.

HDMI - IN 1

Input sockets for connection to the output socket of a SACD player.

HDMI - IN 2

Input sockets for connection to the output socket of an HDMI source device.

These sockets can be reassigned for connection to other HDMI equipment (e.g. an HDMI DVD player or a satellite receiver).

28 DIGITAL IN 1 / IN 2 / IN 3

Audio input sockets for connection to the digital (coaxial) output socket of digital playback/recording equipment.

IN 1: DVD player/recorder

IN 2: CD player/recorder

IN 3: Any digital (coaxial) device.

These sockets can be reassigned for connection to other digital playback/recording equipment (e.g. a CD player/recorder, DVD player/recorder).

DIGITAL OUT

Output socket for connection to the digital input socket of a CD recorder.

3.3 Remote control

Notes

- This remote control is a Philips system remote control which is capable of controlling other Philips equipment as well. Your DFR9000 however does not operate all functions of other equipment. If you wish to operate specific functions of other Philips equipment, please refer to the Instructions for Use, supplied with the respective equipment.
- Your DFR9000 can only be controlled via the remote control if the remote control is set to RECVR.
- Buttons with a blue function description can only perform this function in RECVR (receiver) mode.

1 

Switches the DFR9000 on and to standby.

2 AUDIO DIRECT

Switches between audio delay on and off. Audio delay must first be enabled in the system menu.

3 SELECT

Selects the device you wish to operate via the remote control. In RECVR mode, the DFR9000 can be operated. In DVD, TV and DVD+RW mode, Philips DVD players, TVs and DVD recorders can be operated.

Status window

Shows the selected device (underlined).

4 Source selection buttons

- In RECVR mode these buttons select the required source (only sources configured in the A/V input menu your DFR9000. See '10.7 A/V input menu').
- When SACD is selected as source, the SACD button toggles between audio input 1 and audio input 2. See '4.5 Connecting analogue multichannel equipment' and '4.6 Connecting digital HDMI equipment'.
- When TUNER is selected as source, the TUNER button toggles between FM, FM-M(ono), MW and DAB broadcasting.
- When system menu sub-item 'Audio in' (in 'Configuration' menu) is set to '3 x stereo', the CD/CDR button toggles between CD and CDR input.

Numerical keypad (0-9)

Your DFR9000 does not support this function.

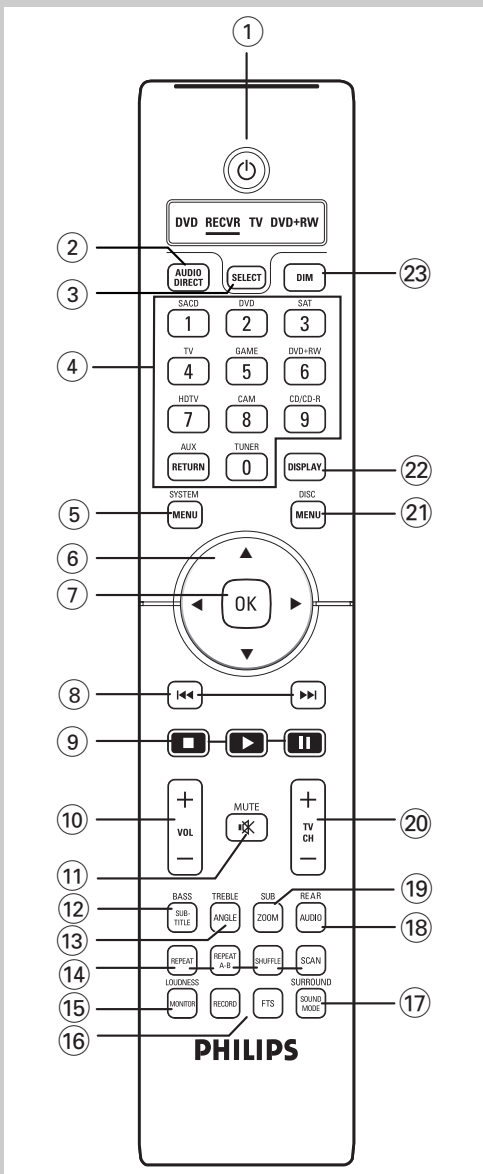

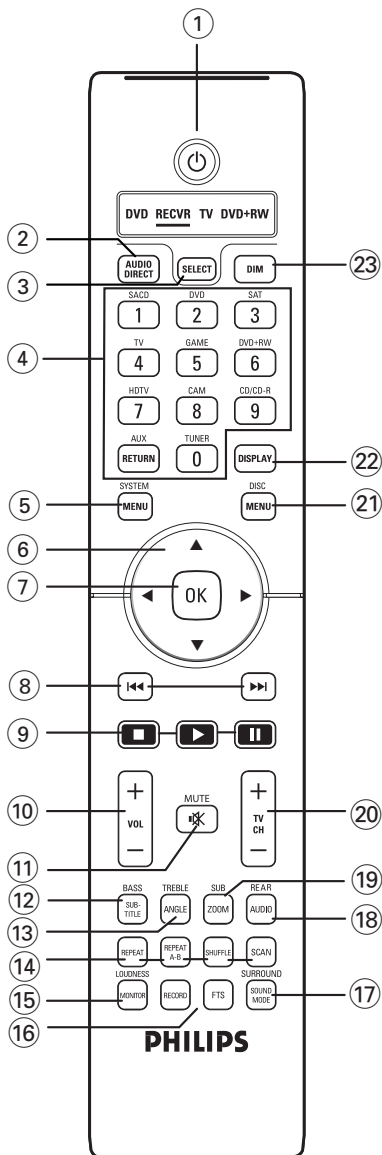

5 SYSTEM MENU

Opens and close the system menu.

6 ▲, ▼, ◀ and ▶

- Navigates in up (▲), down (▼), left (◀) and right (▶) direction in the system menu.
- Selects next (▼, ▶) or previous (▲, ◀) preset station in Tuner and DAB mode.

7 OK

- Confirms actions in the menu.
- Selects secondary audio services in DAB mode.

8 ◀▶▶▶

- Search previous/next frequency in TUNER mode.
- Select previous/next broadcasting frequency in DAB mode.

9 ■ (STOP) / ▶ (PLAY) / || (PAUSE)

In system menu mode, the ■ (STOP) closes the menu without storing any settings. The other functions are not supported by your DFR9000.

10 –VOL +

Adjusts the volume up (+) and down (–).

11 MUTE

Mutes speaker and headphones output.

12 BASS / SUBTITLE

Enables the –VOL + button to adjust the low frequency response.

13 TREBLE / ANGLE

Enables the –VOL + button to adjust the high frequency response.

14 REPEAT / REPEAT (A-B) / SHUFFLE / SCAN

These buttons have no function.

15 LOUDNESS / MONITOR

Switches loudness on and off.

16 RECORD / FTS

This button has no function.

17 SURROUND / SOUND MODE

Selects the various available surround modes. What surround modes are available is dependent on the number of speakers connected and the type of input signal (stereo or multichannel).

18 REAR / AUDIO

Enables the –VOL + button to adjust the volume of the surround rear speaker.

19 SUB / ZOOM

Enables the –VOL + button to adjust the volume of the subwoofer.

20 –TV CH +

Selects TV channels up (+) and down (–).

21 DISC MENU

These buttons have no function.

22 DISPLAY

In tuner mode: Toggles between RDS name and frequency on left display.

In DAB mode: Toggles between station name, programme type, ensemble, signal strength information on left and middle display.

In other (AV) modes: Toggles between surround mode information, video input information, audio input information and type of incoming signal (video- and audio stream information).

Information is shown on left and middle display.

23 DIM

Decreases/increases display brightness.

3.4 Displays

Left display

This display informs you on the current status of the active source.

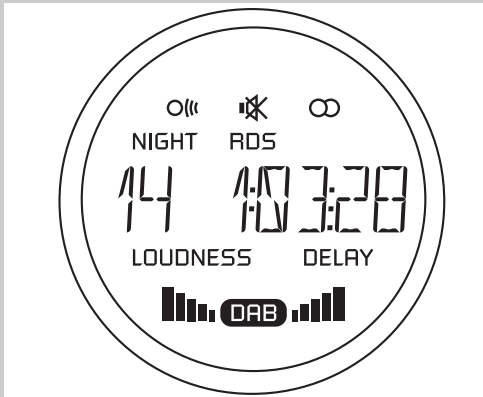

■■■■■■■■

This section of the display indicates the selected source, selected waveband, preset radio station number, tuner frequency, audio/video selection and shows feedback of the receiver during operation.

- 🔇 - Sound of active source muted.
- 📶 - Signal from remote control received.
- 🔊 - Radio station received in stereo.
- NIGHT** - Night mode selected.
- RDS** - RDS radio station is being received.
- DELAY** - Audio delay activated.
- LOUDNESS** - Loudness activated.
- DAB** - DAB broadcasting activated. Flashes if secondary audio services are available.
- - Indicate reception quality level.

Centre display

This display informs you on the the type of incoming audio signal, selected surround modes and displays the system menu, submenus and menu settings.

For an explanation of surround modes see '9. Surround modes'.

For an overview and expansion of menu items see '10. System menu overview'.



Input signal indications:

- DOLBY DIGITAL EX** - Dolby Digital EX available.
- DOLBY DIGITAL** - Dolby Digital available.
- DTS ES** - DTS ES available.
- DTS 96/24** - DTS 96/24 available.

■■■■■■■■

This section of the display is used for feedback of the receiver; selected wavebands, preset radio station numbers, tuner frequencies, selected sources, selected surround modes, audio/video indication, values, menu information and scrolling text.

Right display

This display informs you of the current channel output.

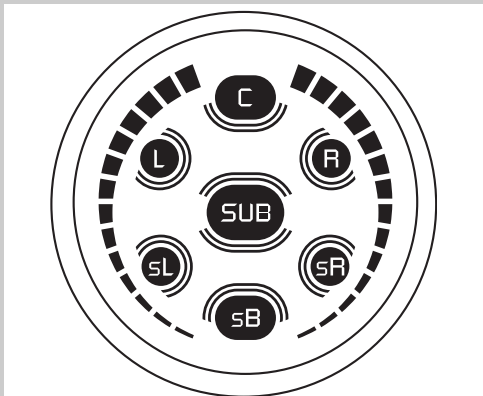

- C** - Centre speaker channel active.
- L R** - Left and right speaker channels active.
- SL SR** - Surround left and right speaker channels active.
- SUB** - Subwoofer channel active.
- SB** - Surround back channel active.
- ⦿ - Volume level indication.

4. Installation

4.1 General remarks

- Most input sockets of your DFR9000 are assigned for connection to a specific device. In the next chapters we will therefore only describe how to connect these specific devices to your DFR9000. If you wish to connect other devices, you first reassign the sockets for connection to these devices. This can be done in the system menu. For this see '6.7 Reassigning input sockets' and '10.7 A/V Input menu'. Connections can then be made as described below. Please refer to the chapter 'Functional overview' for an overview of connectors and the devices they are assigned to.
- The numbers between brackets refer to the numbers in the illustrations on page 3.
- The arrows in the illustrations indicate the direction of the signal.

4.2 Connecting to your TV

SCART/RGBS connection

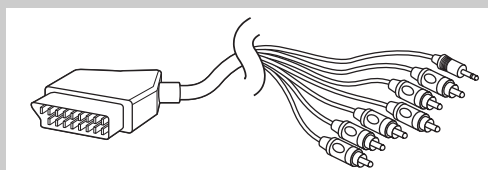
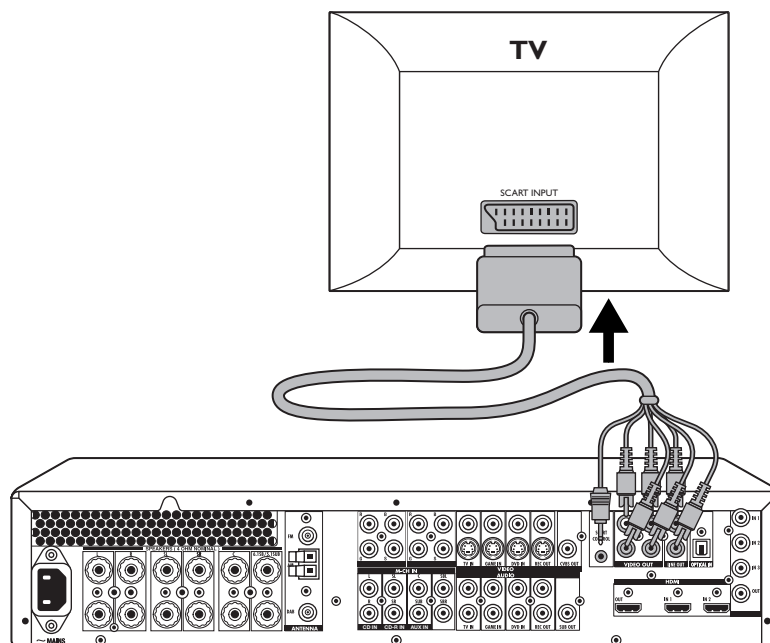

- Make sure the receiver is switched off and unplugged from the wall outlet before making any connections.
- Connect the Scart control (2.5 mm jack) of the 6-cinch + Scart control to Scart cable supplied to the SCART CONTROL connector (22) of your DFR9000.
> When your DFR9000 is reactivated after being switched off, Scart control switches your Scart-enabled TV to the correct input source immediately.
- Connect the red, green, blue and yellow plugs of the cable to the corresponding VIDEO OUT connectors (22) of your DFR9000.
- Connect the red and white audio plugs of the cable to the corresponding LINE OUT connectors (22) of your DFR9000.
- Connect the Scart connector at the other end of the cable to the Scart input connector of your TV.

S-Video / CVBS connection

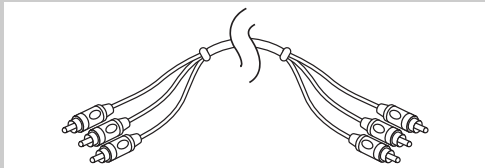
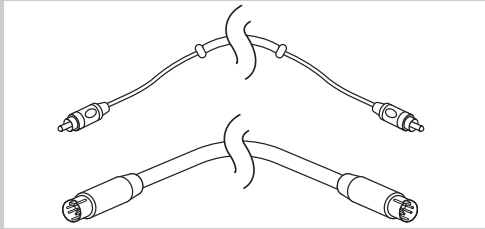
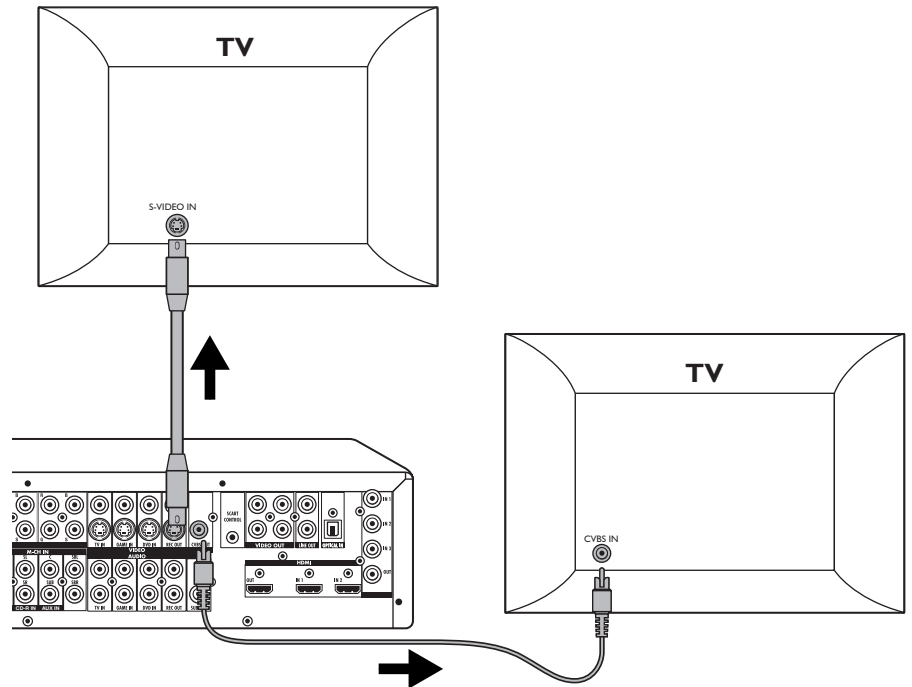

- If your TV is equipped with an S-Video input socket you can connect this socket to the REC OUT output socket (21 - lower row) of your DFR9000. For this, use an optional S-Video connection cable.
- If your TV is equipped with a CVBS input socket you can connect this socket to the CVBS output socket (21) of your DFR9000. For this use an optional 1-inch connection cable.

Notes:

- If your TV is equipped with progressive scan component video, connect an optional 3-inch connection cable to the RGB sockets (22) of your DFR9000.
- For connection to a TV with an HDMI input socket see 'Connecting HDMI equipment'.

4.3 Connecting analogue stereo audio equipment

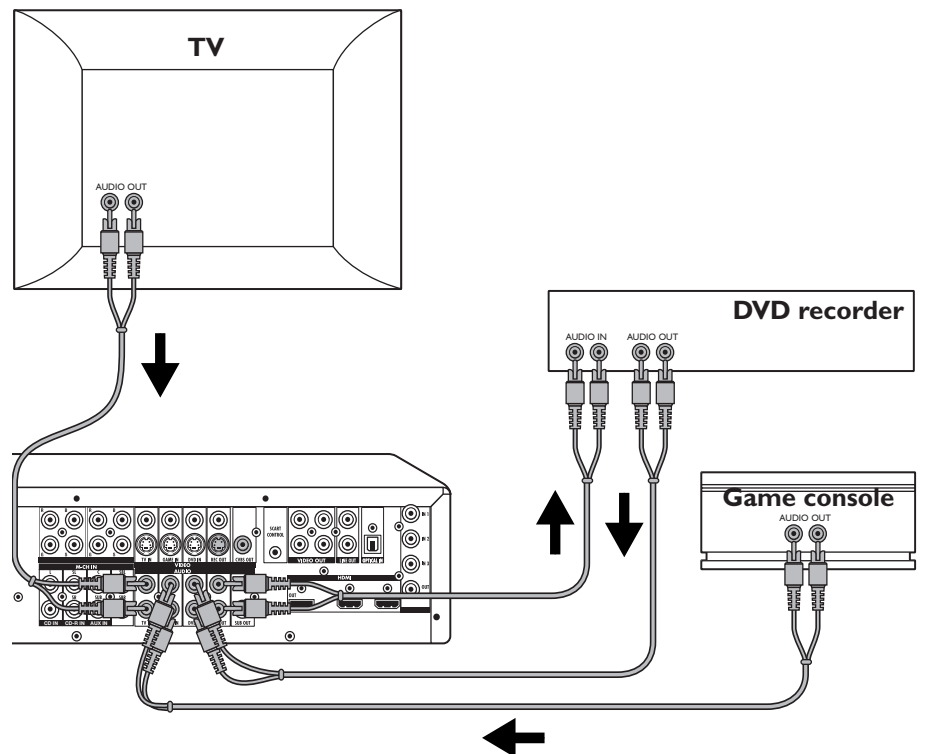

For connection to analogue audio equipment, six input sockets (AUDIO:TV IN, GAME IN and DVD IN - 25) and two output sockets (REC OUT 25) are available.

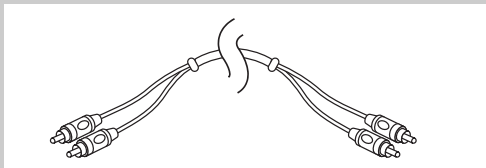

If you do not connect multichannel equipment (e.g. a SACD player) you can reassign the L/R, SL/SR and C/SUB sockets (24) for connection to analog audio equipment (CD IN, CD-R IN and AUX IN). For equipment you want to record with, you need to connect four plugs to the receiver (a set of stereo inputs and a set of stereo outputs). For playback devices, you only need to connect one set of stereo plugs.

For connection of analogue audio equipment, one 2-cinch audio cable is supplied.

- Make sure the receiver is switched off and unplugged from the wall outlet before making any connections.
- Connect the Audio Out sockets of a TV to the TV IN sockets (25) of your DFR9000.
- Connect the Audio Out sockets of a game console to the GAME IN sockets (25) of your DFR9000.
- Connect the Audio Out sockets of a DVD player/recorder to the DVD IN sockets (25) of your DFR9000.
- Connect the Audio In sockets of a DVD recorder to the REC OUT sockets (25) of your DFR9000.

> You can now adjust the sound of all analogue sources connected, using the sound controls of the receiver:

You can also record from the tuner and any additional source connected.

4.4 Connecting digital audio equipment

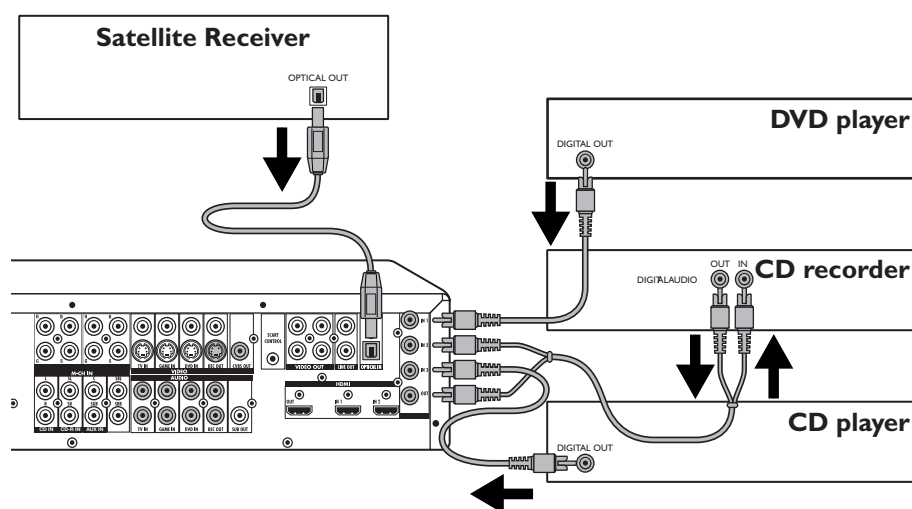

For connection to digital audio equipment, three digital input sockets (DIGITAL IN 1, IN 2 and IN 3 - 28), one optical/digital input socket (OPTICAL IN -23) and one digital output socket (DIGITAL OUT - 28) are available. The OPTICAL IN socket is for connection to digital playback equipment with optical output sockets that supply a digital signal via an optical path.

If you connect the DIGITAL OUT socket to the digital input of a digital recording device (e.g. a CD recorder) you can make direct digital recordings with this unit.

For equipment you want to record with, you need to connect two plugs to the receiver (one digital input and one digital output). For equipment that only plays, you only need to connect one plug.

For connection of digital (coaxial) audio equipment, one digital cinch (coaxial) cable is supplied. For connection to digital (optical) audio equipment, a digital (optical) cable is required.

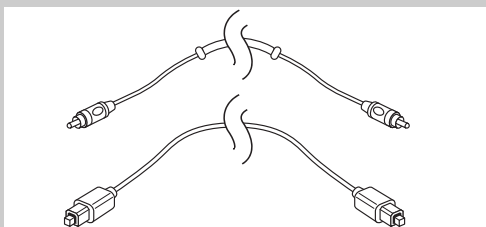

- Make sure the receiver is switched off and unplugged from the wall outlet before making any connections.
- Connect the optical output socket of a satellite receiver to the OPTICAL IN socket (23) of your DFR9000.
- Connect the digital output socket of a DVD player to the DIGITAL IN 1 socket (28) of your DFR9000.
- Connect the digital output socket of a CD recorder to the DIGITAL IN 2 socket (28) of your DFR9000.
- Connect the digital input socket of a CD recorder to the DIGITAL OUT socket (28) of your DFR9000.
- The DIGITAL IN 3 socket (28) of your DFR9000 is not assigned to any special device. You can connect any digital playback device to it, e.g. a CD player.

> You can now adjust the sound of any digital source connected, using the sound controls of the receiver:

You can also record from the tuner and any additional source connected.

Note: Digital recordings are only possible if not copy protected. For recording on a stereo recording device, do not use menu option 'Raw' ('Configuration' menu).

4.5 Connecting analogue multichannel equipment

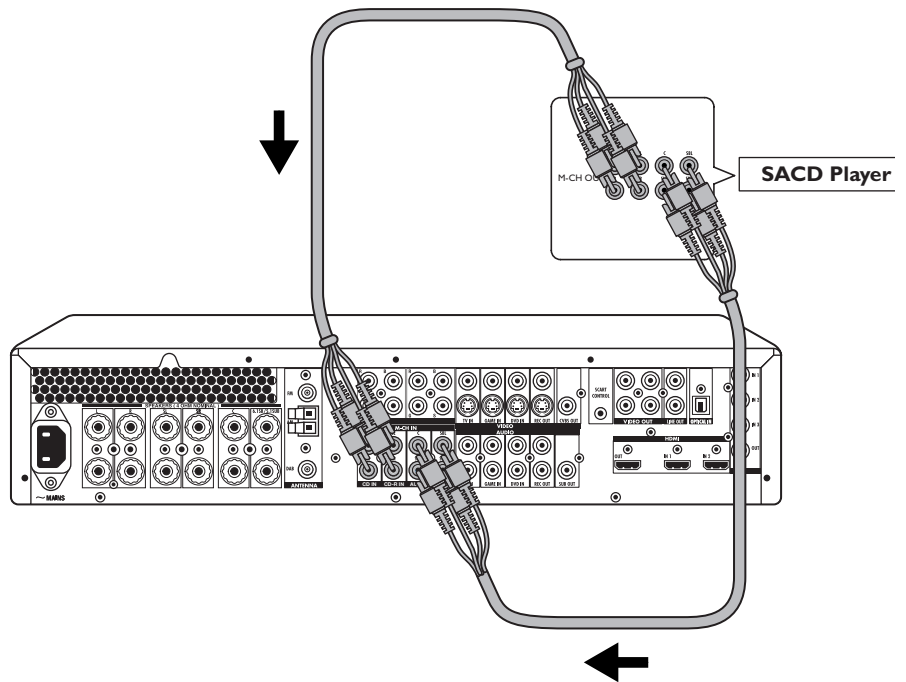

Your DFR9000 is equipped with eight multichannel audio inputs, allowing multichannel connection up to 7.1.

For multichannel connection, two 4-cinch audio cables are supplied.

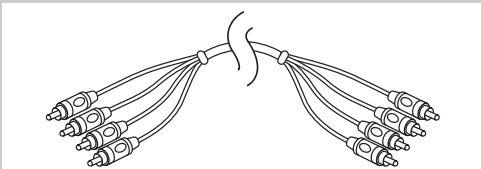

- Make sure the receiver is switched off and unplugged from the wall outlet before making any connections.
- Connect the SURROUND 'L' and 'R' output sockets of an SACD player to the M-CH IN (24) 'SL' and 'SR' input sockets of your DFR9000.
- Connect the CENTRE output socket of of an SACD player to the M-CH IN (24) 'C' input socket of your DFR9000.
- Connect the SUBWOOFER output socket of of an SACD player to the M-CH IN (24) 'SUB' input socket of your DFR9000.
- Connect the SURROUND 'BACK 'L' and 'R' output sockets of an SACD player to the M-CH IN (24) 'SBL' and 'SBR' input sockets of your DFR9000.
- Select 'SACD 1' in the 'A/V input' menu. See '5. System menu' and '10.7 'A/V input menu'.
> You can now adjust the sound of any multichannel source connected, using the sound controls of the receiver:

Notes:

- If you wish to play regular CDs or DVDs in your SACD player, you must also make an additional audio connection for playing regular CDs and DVDs otherwise the SACD player might output the signal to the wrong output sockets.
- In case your multichannel device has only one surround rear output socket ('L' or 'R') this socket can be connected to either the 'SBL' or the 'SBR' socket.
- Depending on the bass management of the source device, the subwoofer gain of the multichannel analogue audio input can be adapted in the 'Configuration' menu, sub-menu 'M(ultichannel) Subw(oofer) (Gain)'. See '10.1 Configuration menu'.
- If no multichannel equipment is available the L/R (CD IN), SL/SR (CDR-IN) and C/SUB (AUX IN) sockets can be connected to the output sockets of analogue audio equipment. The sockets must first be reassigned in the system menu. For this see '6.7 Reassigning input sockets' and '10.1 Configuration menu' ('Audio in'). The SBL/SBR sockets have no function when no multichannel equipment is connected.
- Make sure the SACD player (or other analogue multichannel source device) has the same speaker setup as your DFR9000.

4.6 Connecting digital HDMI equipment

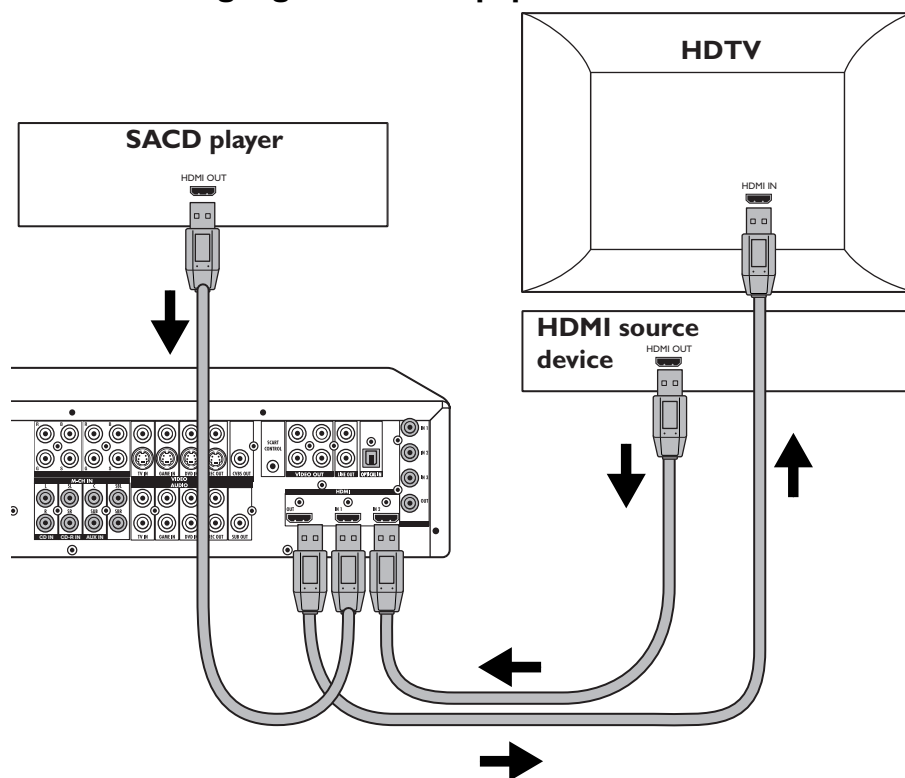

HDMI (High-Definition Multimedia Interface) provides the highest quality high-definition video and multichannel audio. HDMI can carry both uncompressed high-definition video and multichannel audio in all HD formats. Therefore just one single cable is needed for connecting your DFR9000 to HDMI-enabled equipment. Your DFR9000 has one HDMI output for connecting to an HDTV and two HDMI inputs for connecting to an HDMI-enabled SACD player and another HDMI source device.

For HDMI connection an optional HDMI connection cable is required.

Notes:

- HDMI connection can only be made to HDMI-equipped components with HDCP (High Bandwidth Digital Content Protection). If you wish to connect to a DVI connector (equipped with HDCP), you will need a separate adapter (DVI to HDMI) to do so. A DVI (with HDCP) connection, however, does not support audio signals. Consult your local audio dealer for more information.
- If you are using an HDMI source device with HDCP as input to your DFR9000, the output device (e.g. a TV) also has to be connected via HDMI (with HDCP).
- No high definition audio data (SACD, DVD-Audio) via HDMI is supported!

- Make sure the receiver is switched off and unplugged from the wall outlet before making any connections.
- Make sure a multichannel connection has been made. See '4.5 Connecting analogue multichannel equipment'.
- Connect the HDMI output socket of an HDMI-enabled SACD player to the HDMI IN 1 input socket (27) of your DFR9000.
- Connect the HDMI output socket of an HDMI source device to the HDMI IN 2 input socket (27) of your DFR9000.
- Connect the HDMI input socket of an HDTV to the HDMI OUT output socket (27) of your DFR9000.
- Select 'SACD 2' in the 'A/V input' menu. See '5. System menu' and '10.7 'A/V input menu'.

4.7 Connecting video equipment

Your DFR9000 is equipped with RGBS (VIDEO 1 IN - 19 and VIDEO 2 IN - 20), S-Video (VIDEO -21 - lower row) as well as CVBS (VIDEO - 21 - upper row) input/output sockets for connecting video equipment.

For RGBS connection one 6-cinch to Scart cable is supplied.

Scart/RGBS connection

Note: DIGITAL IN 1 (28) and OPTICAL IN (23) are assigned as audio inputs for VIDEO 1 IN (19) and VIDEO 2 IN (20). If the connected sources do not provide digital output, you should reassign other (analogue) audio input sockets for audio connection to this specific device. For this see '6.7 Reassigning input sockets' and '10.7 A/V Input menu'.

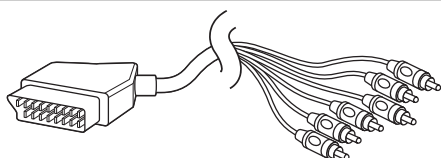

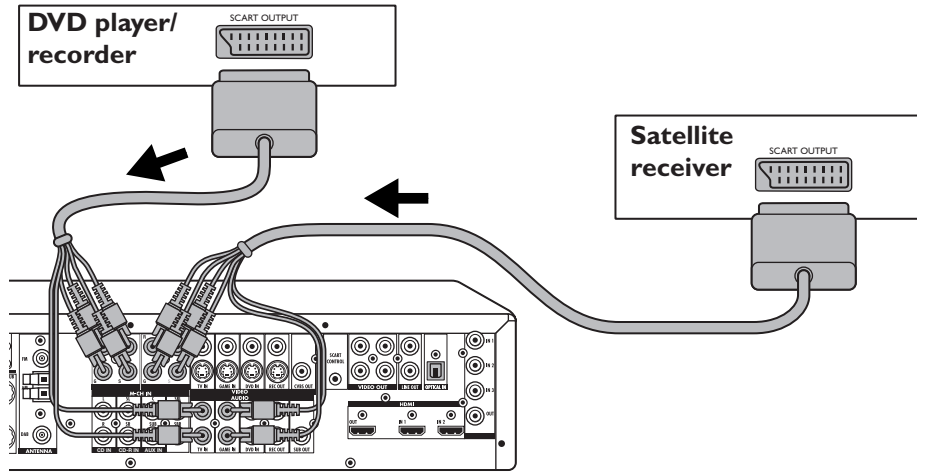

- Make sure the receiver is switched off and unplugged from the wall outlet before making any connections.
- Connect the red, green, blue and yellow plugs of a 6-cinch to Scart cable to the corresponding VIDEO 1 IN input sockets (19) of your DFR9000.
- Connect the red and white audio plugs to the input sockets you reassigned for audio connection. E.g. TV IN (25).
- Connect the Scart connector at the other end of the cable to the Scart output connector of a DVD player/recorder.
- Connect the red, green, blue and yellow plugs of a 6-cinch to Scart cable to the corresponding VIDEO 2 IN input sockets (20) of your DFR9000.
- Connect the red and white audio plugs to the input sockets you reassigned for audio connection. E.g. GAME IN (25).
- Connect the Scart connector at the other end of the cable to the Scart output connector of a satellite receiver.

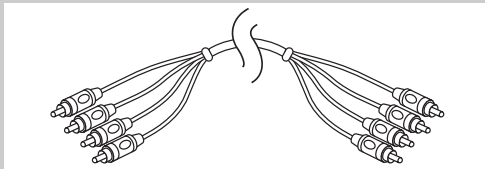

Note: If your DVD player/recorder or satellite receiver is equipped with RGBS output sockets you can connect these sockets to the appropriate VIDEO IN sockets (19, 20) of your DFR9000. For this use one of the 4-cinch connection cables supplied.

S-Video connection

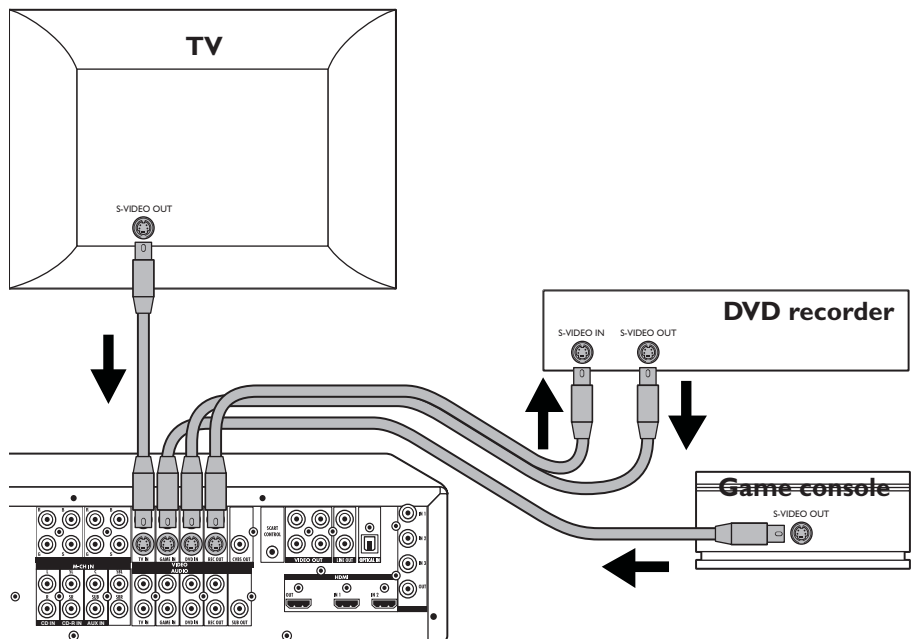

- Make sure the receiver is switched off and unplugged from the wall outlet before making any connections.
- Connect an optional S-Video connection cable between the S-Video output of a TV and the VIDEO TV IN input socket (21 - lower row) of your DFR9000.
- Connect an optional S-Video connection cable between the S-Video output of a game console and the VIDEO GAME IN input socket (21 - lower row) of your DFR9000.

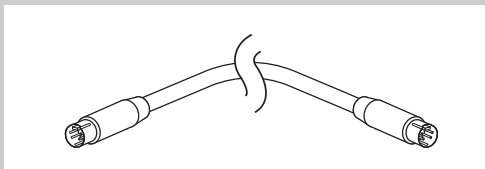

- Connect an optional S-Video connection cable between the S-Video output of a DVD player/recorder and the DVD IN input socket (21 - lower row) of your DFR9000.
- Connect an optional S-Video connection cable between the S-Video input of a DVD recorder and the REC OUT output socket (21 - lower row) of your DFR9000.
- For audio connection to the TV, game console and DVD player/recorder, see 'Connecting analogue equipment.'

CVBS connection

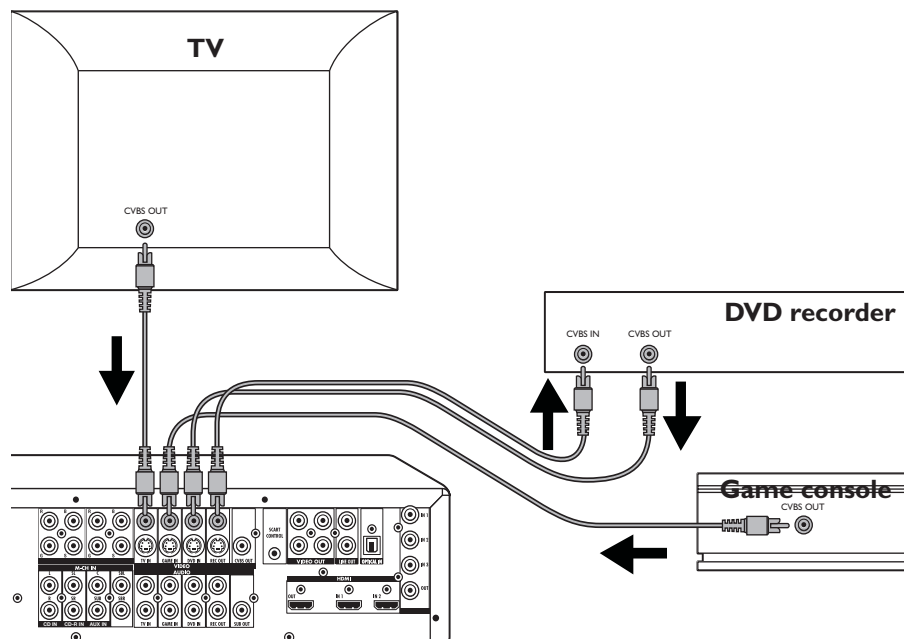

- Make sure the receiver is switched off and unplugged from the wall outlet before making any connections.
- Connect an optional 1-cinch connection cable between the CVBS output of a TV and the VIDEO TV IN input socket (21 - upper row) of your DFR9000.
- Connect an optional 1-cinch connection cable between the CVBS output of a game console and the VIDEO GAME IN input socket (21 - upper row) of your DFR9000.
- Connect an optional 1-cinch connection cable between the CVBS output of a DVD player/recorder and the DVD IN input socket (21 - upper row) of your DFR9000.
- Connect an optional 1-cinch connection cable between the CVBS input of a DVD recorder and the REC OUT output socket (21 - upper row) of your DFR9000.
- For audio connection to the TV, game console and DVD player/recorder, see 'Connecting analogue equipment.'

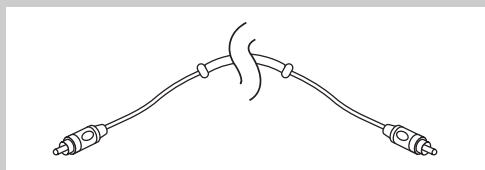

4.8 Connecting speakers

We will describe connection of a complete setup of seven speakers (including subwoofer and surround back speaker), but everyone's home setup will vary. Simply connect the speakers you have as described below. The receiver will work with just two stereo speakers (the front speakers in the illustration) but a complete setup is best for surround sound. As a minimum we recommend five speakers (two front speakers, a centre speaker and two surround speakers) for good surround sound. It is possible to reproduce some kind of surround sound with fewer speakers. This is done by redirecting the signals which are intended for the missing speakers to the existing ones. See '6.4 Setting the speaker size and distance', '6.5 Setting the speaker volume', '10.2 Balance menu' and '10.3 Speakers menu' on how to set up the receiver correctly for the number and size of the speakers used.

Notes:

- Always switch off your receiver before making any connections.
- Speakers with a nominal impedance of 4 Ω and 8 Ω can be connected, but speakers with a nominal impedance of 4 Ω give the best performance.

General

- 1 Twist exposed wire strands together.
- 2 Loosen speaker terminal and insert exposed wire.
- 3 Make sure you connect the speaker on the right to the right terminal and the speaker on the left to the left terminal. Also make sure the + and - cables are connected to the correct speaker terminals (\oplus to \oplus and \ominus to \ominus).
- 4 Tighten terminal.

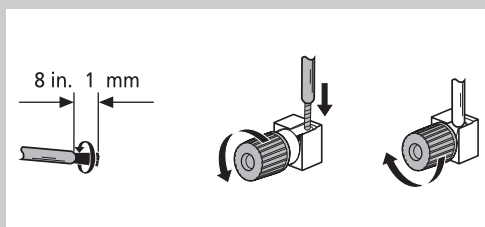

Connecting the speakers

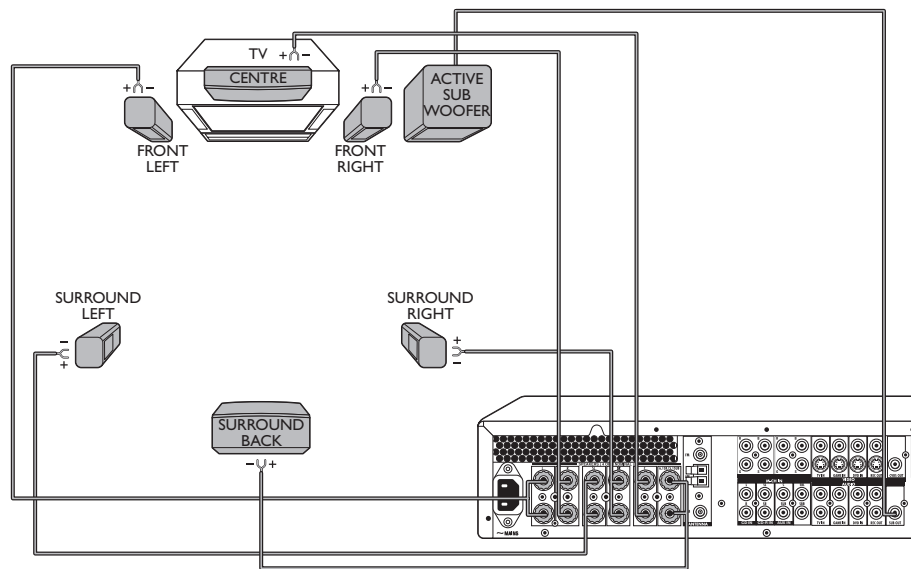

- Connect the left front speaker to the L(ef) terminals (17) and the right front speaker to the R(ight) terminals (17).
- Connect the left Surround speaker to the S(urround) L(ef) terminals (17) and the right Surround speaker to the S(urround) R(ight) terminals (17).
- Connect the centre speaker to the C terminal (17).

If you wish to connect an active subwoofer:

- Connect the active subwoofer to the SUB OUT terminal (26).
- The Surround back speaker can be connected to the 6.1 S(urround) B(ack)/5.1 SUB terminals (17).

For a 5.1 (or less) speaker configuration / if you wish to connect a passive subwoofer:

- Connect the passive subwoofer to the 6.1 S(urround) B(ack)/5.1 SUB terminals (17).

4.9 Positioning the speakers

Speaker positioning in a multichannel home theatre system can noticeably improve the quality of sound reproduced. Speakers are usually designed to perform best at a particular position. This could be on the floor, on stands, near the wall or away from walls.

Below you will find a few tips on getting the best sound from your speakers, but you should also follow the instructions on positioning in the Instructions for use, supplied with your speakers to get the most out of them.

General hints for positioning

- If possible, use the same model or brand of speakers for all front speakers. This creates a seamless front soundstage and eliminates the possibility of distracting sonic disturbances that occur when a sound moves across mismatched front-channel speakers.
- Avoid positioning the speakers in a corner, as this will boost the bass tones too much.
- Placing the speakers behind curtains, furniture etc. will reduce the treble response, thus reducing the stereo effect considerably. The listener should still be able to 'see' the speakers.
- Each room has different acoustic characteristics and the positioning possibilities are often limited. You can find the best position for your speakers by experimenting. In general, the speakers should be arranged as symmetrically as possible in the room.

Positioning the front speakers

- Place the front left and right speakers at equal distances from the TV.
- The front speakers should be arranged so that, viewed from the listener's position, the speaker connected to the 'L' terminals of the receiver is on the left and the speaker connected to the 'R' terminals is on the right of the listener. This can be checked with the balance control in the system menu.
- The best stereo effect is obtained when the two front speakers and the listener form an equilateral triangle.

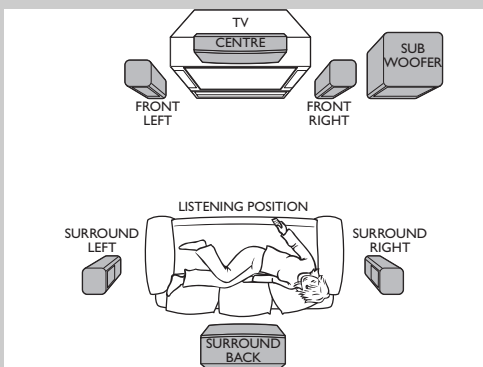

- The best height for the front speakers is when the high tone speakers (tweeters) are at ear height (while seated).
- To avoid magnetic interference with the picture on your TV, do not position the front speakers too close to the TV.

Positioning the centre speaker

- The centre speaker should be placed centrally between the front speakers, e.g. underneath or on top of the TV.
- The best height for the centre speaker is at the height of your ears (while seated).

Positioning the surround speakers

- The surround speaker connected to the 'SL' terminals of the receiver should be on the left and the speaker connected to the 'SR' terminals on the right of the listener. This can be checked with the balance control in the system menu.
- If possible, place the surround speakers slightly above ear level.
- The left and right surround speakers should face each other and be in line with the listener or behind him.
- Place the surround back speaker right behind the listener at the same distance and height as the surround left and right speakers.
- Try not to place the surround speakers further away from the listening position than the front and centre speakers. Doing so can weaken the surround sound effect.

Positioning the subwoofer

A subwoofer can be used to enhance the bass performance of your system.

- If possible, place the subwoofer to the left or right of the centre speaker as seen from the front of the centre speaker.
- Bass level can be increased by placing the subwoofer closer to a corner.

4.10 Connecting antennas

Caution!

Always make sure the receiver is switched off and unplugged from the wall outlet before making or changing any connections.

FM antenna

- For best reception connect the FM connector (18) to the community or cable antenna system or to a roof-mounted FM antenna with an impedance of 75 OHM (Ω).
- If none of these is available, you may use the wire antenna supplied for nearby stations (reception could be poor).
- Vary the position and direction of the antenna until you find the strongest FM reception and then secure the antenna in that position.

DAB antenna

- Connect the DAB antenna supplied to the DAB connector (18) of your DFR9000. Hang up the antenna in a T-shape, turned 90° to the side, preferably close to a window.
- Do *not* attach the antenna to a metal surface.
- Vary the position and direction of the antenna until you find the strongest reception and then secure the antenna in that position.

AM antenna

- Connect the wires of the AM antenna supplied to the AM antenna connector (18).
- Make sure that the antenna terminals close on the bare wire of the antenna and not on the plastic insulation.
- Turn the antenna for optimum reception.

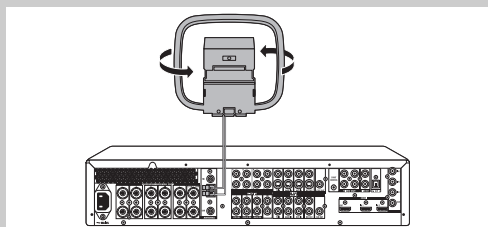
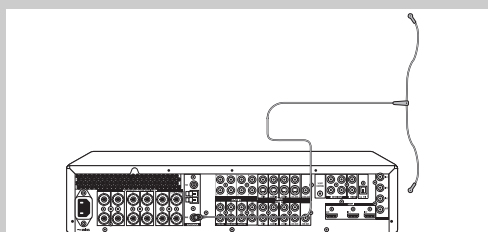
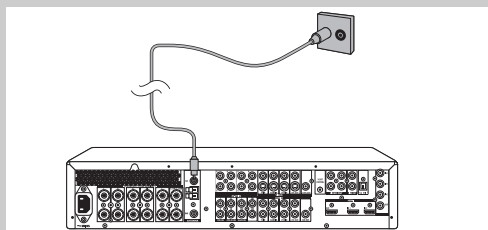

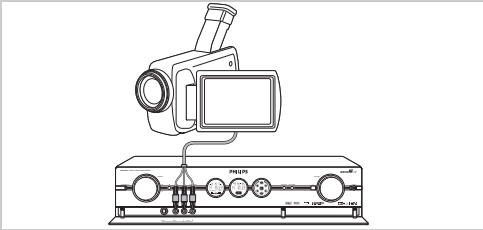

4.11 Connecting a video camera (or other portable external sources)

- 1 Make sure the receiver is switched off and *unplugged* from the wall outlet before making any connections.
 - 2 Open the flap (14) on the receiver front.
 - 3 Connect the Video and Audio 'L' and 'R' output sockets of the video camera (or other portable external source) to the Video and Audio 'L' and 'R' input sockets (15) of your DFR9000.
- Or:
- 3 Connect the S-Video output socket of the video camera (or other portable external source) to the S-Video input socket (15) of your DFR9000.

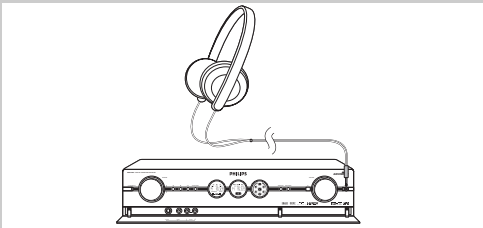

4.12 Connecting headphones

- Connect headphones with a 3.5 mm jack to the PHONES socket (13).
> The speakers are now automatically muted and the sound will be in stereo.

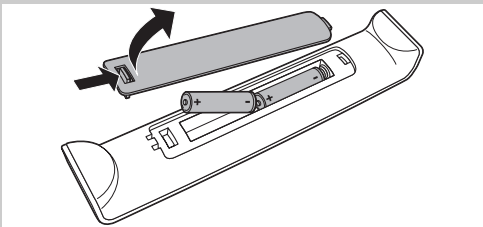

4.13 Inserting the batteries in the remote control

- 1 Remove battery compartment cover and insert two AA (R6, 1.5 V) batteries, noting the + and - configuration in the battery compartment.
- 2 Replace the cover.

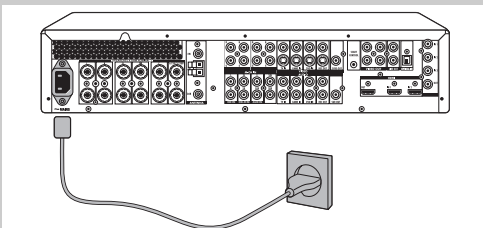

4.14 Connecting to the mains

After you have connected the speakers (and optional equipment) as described, you can connect the unit to the wall socket.

- 1 Check whether the AC voltage, as shown on the type plate (on the bottom of the unit) corresponds to your local AC voltage.
If it does not, consult your dealer or service organisation.
 - 2 **Make sure all connections have been made before connecting your DFR9000 to the mains supply.**
 - 3 Connect the mains lead to the wall socket.
> When the unit is connected to the wall socket, the Standby/On indicator (1) lights up red.
> The AC power supply is now switched on.
- When the set is switched to standby, it is still consuming some power:
To disconnect the set from the mains supply completely, withdraw the mains lead from the wall socket.

Note For users in the U.K.: please follow the instructions on page 2.

5. System menu

All receiver settings (except sound adjustments) are done via On Screen Displays and with help of the following buttons:

on local keyboard: System Menu (5), OK (4), ◀▶ (3) and ▲▼ (2). When the system menu is active, the SOURCE rotary (2) functions as up/down selection button.

on remote control: System menu (5), OK (7) and ◀▶/▲▼ (6).

We will now describe operating your DFR9000 via the buttons on the remote control. If buttons on the local keyboard are required for operation, these buttons will be mentioned.

The receiver is set to standard specifications at the factory. However, you can adjust these specifications to suit your own preferences. Some settings have to be made before operating your DFR9000. For this see '6. Setting up the receiver'. The receiver menu screens allow you to adjust the various settings.

For an overview and explanation of all menus see '10. System menu overview'.

Note: Submenu settings can always be undone by selecting 'Default' at the bottom of that submenu. To reset all user settings to the default factory settings, select 'Reset all' in the 'Configuration' submenu.

5.1 Basic menu navigating

1 Press **⏻** (1) to switch on the receiver.

> The Standby/On indicator (1) on the receiver goes out and 'WELCOME' appears on the middle display.



2 Switch on your TV and select A/V input.

3 Use SELECT (3) to select RECVR.

4 Use the source selection buttons (4) to select the desired A/V source.

5 Press SYSTEM MENU (5) to open the system menu.

> The ring around the SOURCE rotary (2) on the receiver starts flashing and the main menu appears on your TV screen.



> The buttons that can be used for navigating through the menu are shown on the middle display and at the bottom of the TV screen.

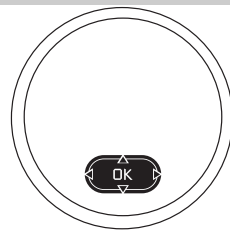

6 Use ▲ and ▼ (6) to select the submenu you wish to change settings for and confirm with ▶ (6).

> The submenu items appear on your TV screen, followed by an overview of possible settings.

7 Use ▲ and ▼ (6) to select an item in the submenu and enter with ▶ (6).

8 Use ▲ and ▼ (6) to set the value and confirm with OK (7).

• Use ◀ (6) or ■ (9) to exit the menu without storing any setting.

9 Press SYSTEM MENU (5) to close the system menu.



6. Setting up the receiver

You can adjust all default receiver settings to suit your own preferences; some settings, however have to be made before operating your DFR9000.

6.1 Positioning your DFR9000

- Place the receiver on a stable, level surface, out of direct sunlight and away from sources of excessive dust, dirt, heat, water, moisture, vibration and strong magnetic fields.
Do *not* place the receiver on a carpet.
- Do *not* place the receiver top of other equipment that might heat up (e.g. another receiver or amplifier).
- Do *not* place anything under the receiver (e.g. CDs, magazines, etc.).
- Allow at least 10 cm clearance from the rear and the top of the receiver and 5 cm from the left and right to prevent overheating.
- Allow sufficient cooling of the receiver by keeping all air inlets and outlets clear of obstructions.
- Do *not* expose the set to dripping or splashing.
- Do *not* place any sources of danger (e.g. liquid filled objects, lighted candles, etc.) on the receiver.
- Active mobile phones near the set may cause malfunctions.

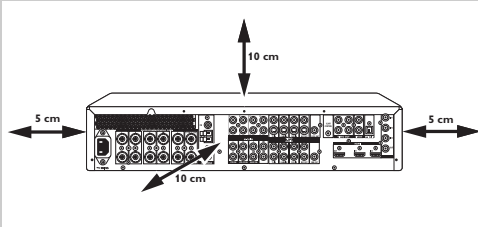

6.2 Switching on and off

- Press **⏻** (1) to switch on the receiver.
> The last selected source will automatically be selected (if still active). The source name will be shown on the left display.
- The receiver can also be switched on by pressing any of the SOURCE selection buttons (4) or by selecting a source with the SOURCE rotary (2) on the local keyboard.

> The Standby/On indicator (1) goes out and 'WELCOME' appears on the middle display.

- Press **⏻** (1) to switch the receiver back into Standby mode.
> The Standby/On indicator (1) on the receiver lights up red.
- To disconnect the receiver from the mains completely, remove the mains plug from the wall socket.

6.3 Selecting your system menu language

- Make sure receiver and TV are switched on and that RECVR. is selected and A/V source are selected.
- Press SYSTEM MENU (5) to open the system menu.
> The main menu appears on your TV screen. The 'Configuration' menu is the first menu that can be selected.
- Use **▶** (6) to enter the 'Configuration' submenu.
> The submenu items appear on your TV screen, followed by an overview of possible settings.
- Use **▲** and **▼** (6) to select 'Language' and enter with **▶** (6).
- Use **▲** and **▼** (6) to select the desired language and confirm with OK (7).
- Press SYSTEM MENU (5) to close the system menu.

6.4 Setting the speaker size and distance

The receiver must know how many speakers are connected and how big they are. The size (large or small) determines the amount of bass, sent from the receiver to the speakers. To ensure the best possible surround sound you must specify the distance from your listening position to the various speakers. This is particularly important when using Dolby surround and DTS. You only need to make these settings once (unless you change the placement of your current speaker system or add new speakers, etc.).

Note: Please refer to the Instructions for Use of your speaker system for more detailed setup information.

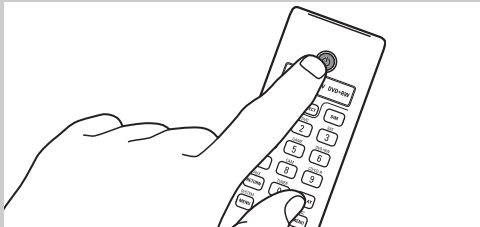

**Tips:**

- When you have connected a passive subwoofer to the 6.1SB/5.1SUB sockets (17) in a 5.1 configuration, 'SB size' must be set to 'Subwoofer'.
- Whenever a subwoofer is connected, 'SUB' must be set to 'YES' or 'Always'.
- For speakers that are not connected, select 'None'.
- The centre speaker is normally placed directly in the front of the listening room and closer to the listening position than the front speakers. This means that sound from the centre speaker will be heard before sound from the front speakers. To prevent this, set the centre speaker distance ('C distance') a little further than it actually is. In this way sound from the front and centre speakers will be heard at the same time.

- 1** Make sure receiver and TV are switched on and that RECVR. is selected and A/V source are selected.
- 2** Press SYSTEM MENU (5) to open the system menu.
> The main menu appears on your TV screen.
- 3** Use ▼ (6) to select 'Speakers' and enter with ▶ (6).
> The submenu items appear on your TV screen, followed by an overview of possible settings.
- 4** Using ◀, ▶, ▼ and ▲ (6) you can now set size and distance for all your speakers. Confirm all adjustments with OK (7).
- 5** Press SYSTEM MENU (5) to close the system menu.

Note: If you have set speakers to 'Small', you should also select a 'Cutoff' frequency in the menu. For the cutoff frequency of your speakers, refer to the Instructions for Use of the speakers.

6.5 Setting the speaker volume

- 1** Make sure receiver and TV are switched on and that RECVR. is selected and A/V source are selected.
- 2** Press SYSTEM MENU (5) to open the system menu.
> The main menu appears on your TV screen.
- 3** Use ▼ (6) to select 'Balance' and enter with ▶ (6).
> The submenu items appear on your TV screen, followed by an overview of possible settings.
- 4** Using ◀, ▶, ▼ and ▲ (6) you can now set the volume for all your speakers. You can also activate a test tone. Confirm all adjustments with OK (7).
- 5** Press SYSTEM MENU (5) to close the system menu.



6.6 Reassigning input sockets

This is *only necessary* if you wish to connect a device for which no socket(s) is/are preassigned.

- To determine the currently assigned audio and video input sockets for a source, switch to this source and press DISPLAY (22).
> The left display shows the selected source, followed by the type of input signal (audio, video). The middle display shows the name(s) of the input socket(s) the source is connected to.
- 1** Make sure receiver and TV are switched on and that RECVR. is selected and A/V source are selected.
 - 2** Press SYSTEM MENU (5) to open the system menu.
> The main menu appears on your TV screen.
 - 3** Use ▼ (6) to select 'AV input' and enter with ▶ (6).
> On your TV screen a list of source names with their audio and video inputs is shown.
 - 4** Use ▼ and ▲ (6) to select the kind of audio or video input you wish to configure for a source. E.g. 'CD audio' for the audio source CD. Enter with ▶ (6).
 - 5** Use ◀, ▶, ▼ and ▲ (6) to select the input sockets you wish to assign for connecting your CD player to. E.g. 'Game in'. Confirm with OK (7).
 - 6** Press SYSTEM MENU (5) to close the system menu.
> The device (CD player) can now be connected to the GAME IN sockets (25).



7. Operating the amplifier

Note: We will describe operating the amplifier via the buttons on the remote control. If buttons on the local keyboard are required for operation, these buttons will be mentioned.

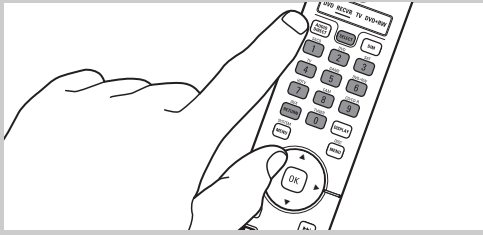

7.1 Source selection

- Use **SELECT (3)** to select RECVR.
> You can now operate your DFR9000.
- Use the **source selection buttons (4)** to select the sources connected to your DFR9000.
> The left display shows the selected source, followed by the type of input signal (audio, video). The middle display shows the name of the input sockets the source is connected to.

Note: If, in the 'AV input' menu, audio and video are set to 'None' for a source, it is not possible to select this source on your DFR9000. See '10.7 A/V input menu'.



7.2 Sound control

- Use **SELECT (3)** to select RECVR.
- Use the **source selection buttons (4)** to select the desired A/V source.

Volume

- Use **-VOL + (10)** to adjust the volume.
- Press **MUTE (11)** to mute the sound of the active source.

Bass

- 1 Press **BASS/SUBTITLE (12)**.
- 2 Use **-VOL + (10)** to decrease/increase the bass response.

Treble

- 1 Press **TREBLE/ANGLE (13)**.
- 2 Use **-VOL + (10)** to decrease/increase the treble response.

Loudness

- Press **LOUDNESS/MONITOR (15)** repeatedly to toggle between loudness on and off.

Rear volume

- 1 Press **REAR/AUDIO (18)**.
- 2 Use **-VOL + (10)** to adjust the volume of the surround speaker.

Subwoofer volume

- 1 Press **SUB/ZOOM (19)**.
- 2 Use **-VOL + (10)** to adjust the volume of the subwoofer.



7.3 Selecting surround modes

What surround modes can be selected depends on which speakers are connected and on the type of the incoming signal. The available surround modes are displayed in the middle display. For an overview and explanation of possible surround modes, see '10. Surround modes'.

- Use **SURROUND (17)** to select the various surround modes.

Installed speakers	L/R	- L/R + C - L/R + SL/SR - L/R + C + SL/SR	- L/R + SL/SR/SB - LR + C + SL/SR/SB
Input signal			
Mono	Mono	Mono	Mono
Stereo (including FM, DAB)	Stereo	1. Stereo 2. DPLII movie 3. DPLII music 4. DTS Neo:6 cinema 5. DTS Neo:6 music	1. Stereo 2. DPLIIx movie 3. DPLIIx music 4. DTS Neo:6 cinema 5. DTS Neo:6 music
Surround	Stereo	1. Stereo 2. Dolby Digital or DTS	1. Stereo 2. Dolby Digital or DTS 3. Dolby Digital EX or DTS ES
Multichannel analogue input	----	----	----

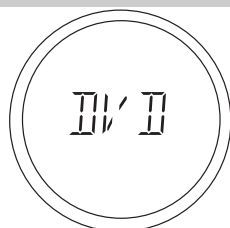

7.4 Playing sources

- 1 Switch on the playback device.
- 2 Press **⏻** (1) to switch on the receiver.
 - > The Standby/On LED goes out and 'WELCOME' appears on the left display.
- 3 Select the required device as source, using the Source selection buttons (4).
- 4 Start playback on the selected source device.

7.5 Recording from sources

When recording, the incoming signal is reproduced by all audio and – if the source includes a video signal – video outputs of the receiver. The sound settings do not affect the recording.

- 1 Switch on the receiver, the device you wish to record from and the recording device.
- 2 Select the device you wish to record from as source.
 - > The selected source name is shown on the middle display.
- 3 Prepare the desired recording source.
 - It must be connected to one of the outputs of the receiver.
 - If necessary, select the input socket ('M-CH IN', 'CD IN', 'CD-R IN', etc) to which the recording device's output socket is connected. See 'Selecting input sockets for recording' hereafter.
- 4 Start recording on the recording device.
- 5 Start the playback of the source you wish to record from.

Note: If the recording device is selected for playback via the amplifier, the REC OUT (25) analogue output socket will be muted to avoid sound feedback loops that can harm your audio equipment.

Selecting input sockets for recording

This is only necessary if one of the following analogue audio input sockets is connected to the recording device: AUDIO:TV IN, GAME IN, DVD IN (25), M-CH IN, CD IN, CD-R IN, AUX IN (24).

- 1 Make sure receiver and TV are switched on and that RECVR. and A/V source are selected.
- 2 Press SYSTEM MENU (5) to open the system menu.
 - > The main menu appears on your TV screen. The 'Configuration' menu is the first menu that can be selected.
- 3 Use **▶** (6) to enter the 'Configuration' submenu.
 - > The submenu items appear on your TV screen, followed by an overview of possible settings.
- 4 Use **▲** and **▼** (6) to select 'Rec audio' and enter with **▶** (6).
- 5 Use **▲** and **▼** (6) to select the desired input socket and confirm with **OK** (7).
- 6 Press SYSTEM MENU (5) to close the system menu.

7.6 Recording from the digital output

Notes:

- When recording a Dolby Digital or DTS signal, each track must be recorded individually.
- Digital recording is not possible from an analogue multichannel source.
- Before you start recording from the digital output, make sure the output is set to match your recording device. See '10.1 Configuration menu' for the appropriate 'Digital out' setting.
- Digital recording is not possible when the digital source material is copy-protected.

If a digital recorder is connected to the DIGITAL OUT socket (28) of the receiver, all signals coming from the digital inputs can be recorded directly on the connected audio recorder (except signals coming from M-CH IN (24)). The receiver will also convert all signals coming from the analogue inputs to the digital output. The receiver can be used to record digitally a multichannel surround sound audio signal (Dolby Digital, or DTS) from, for example, DVD to CD-R. The receiver will convert the digital multichannel signal into a stereo signal without loss of relevant sound information.

8. Operating the tuner

Note: We will now describe operating the tuner via the buttons on the remote control. If buttons on the local keyboard are required for operation, these buttons will be mentioned.

8.1 Tuning to radio stations (FM, FM-M and MW band)

- 1 Press SELECT (3) to select the RECVR.
- 2 Use TUNER (4) to select the tuner as source and select the required waveband (FM, FM-M(ono) or MW). Select FM-M(ono) when FM reception is insufficient.
 - > The selected waveband is shown on the left display.
- 3 Keep ◀◀ or ▶▶ (8) pressed for about 1 second then release.
 - > 'SEARCH' appears on TV screen and middle display. The tuner now starts searching for a radio station with sufficient signal strength.
 - > Waveband and station (station name or frequency) are shown on the TV screen and the middle display. If the radio signal is stereo, ∞ will appear.
- Press ◀◀ or ▶▶ (8) again to interrupt searching.
- 4 Repeat step 3 until you find the desired radio station.
 - To tune to a weak radio station, briefly press ◀◀ or ▶▶ (8) as often as necessary for optimum reception.



8.2 Preset radio stations (FM, FM-M and MW band)

Up to 40 preset radio stations can be stored in the tuner memory.

Preparation

- 1 Make sure your TV is switched on.
- 2 Press SELECT (3) to select RECVR.
- 3 Press TUNER (3) to select the tuner as source.

Automatic searching and storing

Your DFR9000 searches for radio stations with sufficient signal strength automatically and stores them in the memory.

- 1 Press SYSTEM MENU (5) to open the system menu.
 - > The main menu appears on your TV screen.
- 2 Use ▼ (6) to select 'Tuner' and enter with ▶ (6).
 - > The tuner menu appears on your TV screen.
- Press TUNER (4) if you wish to change the waveband.
- 3 'Autoprogram' will be selected. Enter with ▶ (6).
- 4 Use ▲ or ▼ (7) to select the station number from which onwards the found radio stations will be stored and confirm with OK (7).
 - > 'ACTIVE' appears on middle display and TV screen.
 - Automatic search starts and radio stations with sufficient signal strength will be stored in the memory. Already stored radio stations will be deleted. The current station and any higher station will be deleted.
- 5 Press SYSTEM MENU (5) to close the system menu.
 - > Search will stop as soon as 40 radio stations have been stored.

Note: During automatic searching you can leave the 'Tuner' menu to make other settings, 'Active' then starts flashing on the TV screen.

Manual searching and storing

- 1 Press SYSTEM MENU (5) to open the system menu.
 - > The main menu appears on your TV screen.
- 2 Use ▼ (6) to select 'Tuner' and enter with ▶ (6).
 - > The tuner menu appears on your TV screen.
- 3 Use ▼ (6) to select 'Set presets' and enter with ▶ (6).
 - > 'PRESETS' appears on TV screen and middle display.
- 4 Use ▼ and ▲ (6) to select a preset number.
- 5 Use ◀ and ▶ (6) to select a radio station (frequency) you wish to store under the selected number. Confirm with with OK (7).
 - > 'STORE' appears on middle display and TV screen.
 - The radio station is now stored under this number.

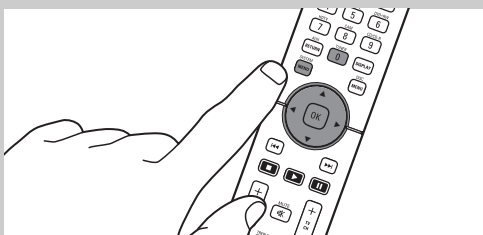
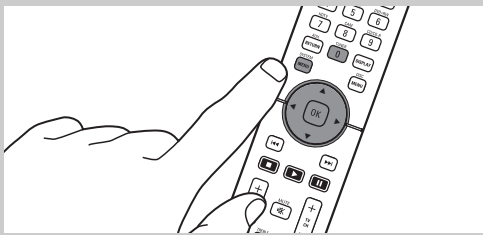

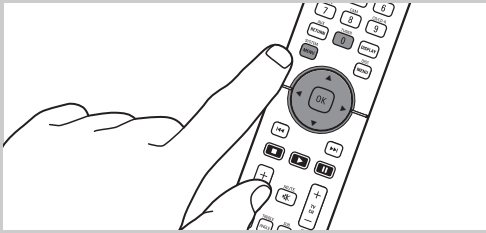

- 6** Store other radio stations in the same way.
- 7** Press SYSTEM MENU (5) to close the system menu.

Moving preset radio stations

- 1** Press SYSTEM MENU (5) to open the system menu.
> The main menu appears on your TV screen.
- 2** Use ▼ (6) to select 'Tuner' and enter with ► (6).
> The tuner menu appears on your TV screen.
- 3** Use ▼ (6) to select 'Move preset' and enter with ► (6).
- 4** Use ▼ or ▲ (6) to select the preset station you wish to move and confirm with OK (7).
> 'XX () XX' appears middle display and TV screen.
- 5** Use ▼ or ▲ (6) to select the number under which you wish to store the preset radio station. Confirm with OK (7).
> 'STORE #' appears on middle display and TV screen. The preset station has now been stored under the new number.
- 6** Restore other preset stations in the same way.
- 7** Press SYSTEM MENU (5) to close the system menu.

Selecting preset radio stations

- In tuner mode (FM, FM-M, MW) use ◀▶▲▼ (7) to select preset stations.
> Waveband, station (station name or frequency) and preset number are shown on the TV screen and the middle display. If the radio signal is stereo, ∞ will appear.

8.3 DAB radio stations

DAB (Digital Audio Broadcast) Digital radio is a new transmission system that carries all the benefits of digital broadcasting. Digital Audio Broadcasting gives you far greater station choice, better reception and clarity of sound with no re-tuning. Useful text information is also received. DAB digital radio does not suffer from the effects of interference caused by adverse atmospheric conditions or electrical interference. With DAB digital radio you get an excellent reception and pure, clear sound all the time, as long as you are within the coverage area. Your DFR9000 combines FM and DAB, giving the widest of listening options as well as improved clarity of sound and more stations. On the TV screen and local displays you can see all kinds of additional information (DLS information - Dynamic Label Service) about the programme on air. This might include the name of a show, phone numbers and email addresses.

Storing DAB radio stations

Up to 99 DAB radio stations can be stored in the tuner memory.

- 1** Press SELECT (2) to select RECVR.
- 2** Use TUNER (4) to select the DAB waveband.
> **DAB** appears on the left display and indicates the signal strength of the broadcasting station.
- 3** Press SYSTEM MENU (5) and use ▼ (6) to select 'Tuner'. Enter with ► (6).
- 4** Use ▼ (6) to select 'DAB scan'. Enter with ► (6).
> 'DAB SCAN' appears on the left display and 'NEW' on the middle display.
- 5** 'New' is selected. Confirm with OK (7).
> 'ACTIVE' starts blinking on TV screen and left display.
DAB radio stations will be stored in alphabetical order. This can take some minutes.
- 6** Press SYSTEM MENU (5) to close the system menu.
> Search will stop as soon as all available DAB radio stations have been stored.

Note: If you wish to add new DAB stations, that are newly available, to the ones already stored without deleting already stored stations, select 'DAB scan' again and then 'Append'. Then follow steps 5 and 6.

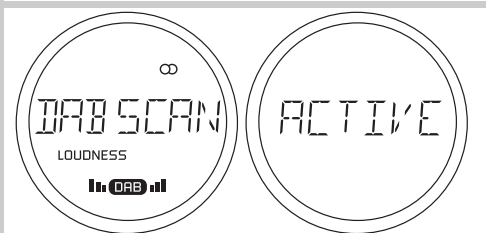
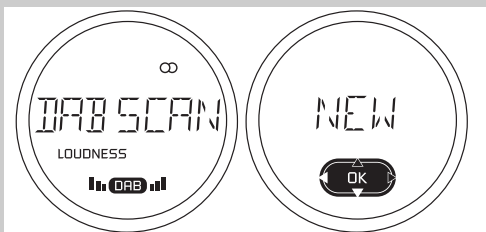
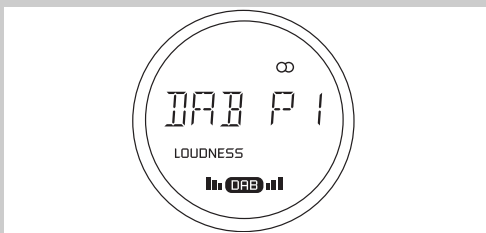

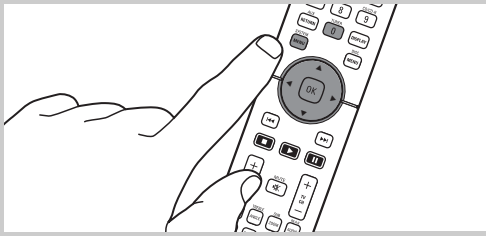

Moving DAB radio stations

- 1 Press SYSTEM MENU (5) and use ▼ (6) to select 'TUNER'. Enter with ► (6).
- 2 Use ▼ (6) to select 'DAB move'. Enter with ► (6).

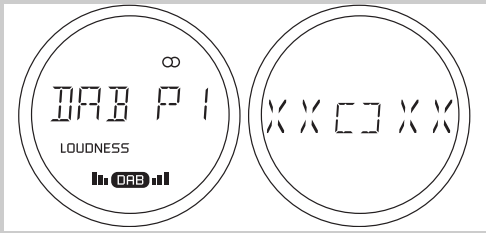

- 3 Use ▼ or ▲ (6) to select the DAB radio station you wish to move.
 - > Station names and numbers are shown on left and middle display and a list of stations is displayed on the TV screen. The number of the station you wish to move is shown in the first 'XX'.
- 4 Confirm with OK (7).
- 5 Use ▼ or ▲ (6) to select the number under which you wish to store the DAB radio station.
 - > The available station numbers are shown in the second 'XX'.
- 6 Confirm with OK (7) when you have found the desired station number.
 - > 'STORED' appears on the middle display. The DAB radio station has now been stored under the new number.
- 7 Move other DAB radio stations in the same way.
- 8 Press SYSTEM MENU (5) to close the system menu.

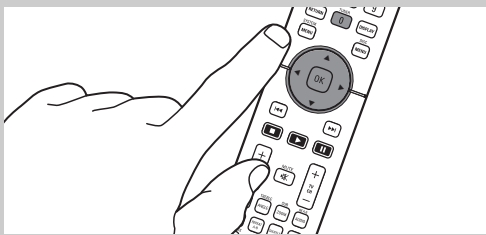

Tuning to DAB radio stations

- In tuner mode (DAB) use ◀ or ▶ (6) to select preset stations.
 - > 'TUNING' appears on middle display and TV screen.

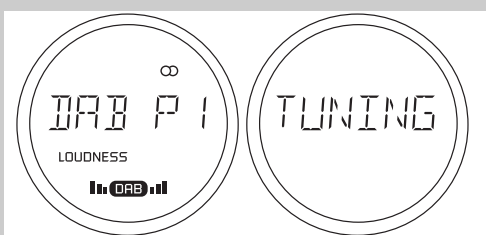

> Station names and numbers are shown on left and middle display and a list of stations is displayed on the TV screen.



> DLS (Dynamic Label Service) information is shown on the lower half of the TV screen.



- > Some DAB radio stations may offer secondary services (e.g. temporary or permanent secondary radio programmes, transmitted on the same frequency). If secondary services are available, **DAB** starts flashing in the left display.
- Press OK (7) to activate a secondary service (e.g. a second radio programme in the background). Use OK (7) to toggle through the available secondary services.

9. Surround modes



Dolby Digital

Dolby Digital is an encoding, transmission and decoding standard for stereo up to 5.1 channels of digital audio. It is available only with digital input sources encoded with Dolby Digital data. It provides up to five separate main audio channels and a special dedicated low-frequency effects channel and delivers high-quality multichannel audio without compromising video performance. Dolby Digital is the world wide audio standard for DVD-Video.

Dolby Digital EX

Available when the receiver is configured for 6.1 channel operation. Dolby Digital EX introduces a centre rear channel to the 5.1 playback format. This additional channel provides increased spatiality and realism for audio effects that pan from front to back, as well as enhanced localization of surround channels that originate from directly behind the listener. When used with movies or other programs that have special encoding, Dolby Digital EX reproduces specially encoded soundtracks so that a full 6.1 soundfield is available. When the receiver is set for 6.1 operation and a Dolby Digital signal is present, the EX mode is automatically selected.

Dolby Pro Logic II x

Processes stereo movie and music content into six independent playback channels of full bandwidth surround sound.

Dolby Pro Logic II x Movie is optimized for movie soundtracks, especially those recorded in Dolby Surround. The channel separation and movement of surround effects is comparable to Dolby Digital EX.

Dolby Pro Logic II x Music is optimized for music. The surround effect is more enveloping than Pro Logic II Movie.

DTS

DTS Digital Surround is a 5.1-channel surround sound format, similar to Dolby Digital. DTS (Digital Theater System) features up to five discrete (independent) channels (front centre, front left, front right, surround left, surround right) of full frequency sound plus a sixth channel for low frequency effects (LFE). The LFE signal is usually reserved for the subwoofer or speakers capable of reproducing low frequency ranges.

DTS ES

DTS Extended Surround is a 6.1-channel surround sound format that extends the 5.1-channel surround sound format with one additional speaker located in the back of the listener (i.e., back surround channel). DTS ES comes in two versions: DTS Extended Surround Matrix and DTS Extended Surround Discrete 6.1.

DTS 96/24

DTS 96/24 offers high-quality 5.1-channel sound playback on DVD-Video and is fully backward-compatible with all DTS decoders. '96' refers to a 96kHz sampling rate (compared to typical 48kHz sampling rate.) '24' refers to 24-bit word length.

DTS Neo:6

DTS Neo:6 provides up to six channels of matrix decoding from stereo matrix material.

Neo:6 Cinema is suitable for movies. Neo:6 Cinema delivers good channel separation for movie soundtracks.

Neo:6 Music is suitable for music. It plays the stereo source more through the front left/right speakers, and generates a natural, ambient surround and centre sound.



Trademark acknowledgment

Manufactured under license from Dolby Laboratories. 'Dolby', 'Pro Logic' and the double-D symbol  are trademarks of Dolby Laboratories.

'DTS', 'DTS-ES', 'Neo:6' and 'DTS 96/24' are trademarks of Digital Theater Systems, Inc.

See type plate license, trademark and warning notices on the bottom of the set.

10. System menu overview

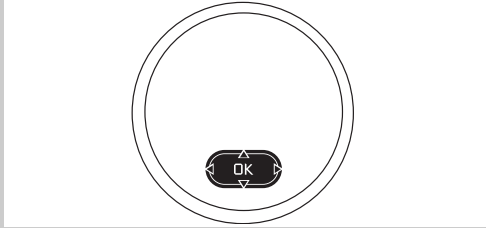

In this chapter we will give an overview and explanation of all menu items and settings. For menu navigation see '6. System menu'. The system menu is accessed by pressing the SYSTEM MENU (5). The buttons that can be used for navigating through the menus are shown on the middle display and on the bottom of the TV screen.

When an item is greyed out this means that it cannot be activated/adjusted (yet).

E.g. 'Move preset' in the 'Tuner' menu when no preset stations are stored yet or 'TV out' in the 'Picture' menu when HDMI enabled equipment is connected.



10.1 Configuration menu

In the 'Configuration' menu you can set basic configuration settings for your DFR9000. Settings can be made for the following items:

Timer

Selects the delay time after which the receiver automatically switches to Standby. The following delay times (in minutes) can be selected: 30 Min, 60 Min, 90 Min and 120 Min. The timer will be set to 'Off' automatically when the receiver is switched to Standby.

Audio delay

(Only available if audio and video exist for the currently selected source.)

Synchronizes the audio and video signal for A/V sources.

Synchronizing is done in steps of 10 milliseconds from 0 to 150. When setting the audio delay time, select the A/V source first before opening the system menu. You can then see the picture on the A/V source and adjust the sound at the same time. The effect can directly be seen on the TV screen. This setting has an extra menu level, indicated by the highlighted ► icon at the bottom of the TV screen and the lit ► icon in the middle display, allowing you to adjust the value using ▲ and ▼ (2). Confirm the adjustment with OK (4) or press ◀ to go back to the previous level without storing the adjustment. You cannot switch to another source while setting the delay time.

C(entre) Width

Shifts the ratio between left/right and centre speaker output.

Use this option to adjust sound reception if stereo sound is used in DPLIIx Music mode.

C(entre) Gain

Adjusts the centre content in the left/right speaker output. To adjust sound reception if stereo sound is used in DTS Neo:6 Music mode.

Night mode

Reduces the volume differences between loud and quiet passages. Night mode is available only for Dolby Digital and DTS signals and only if supported by the source material (e.g. a movie).

Audio in

Selects between 6.1 (7.1) channel input or 3 times stereo input. When selecting 'MULTI-CH' the 'M-CH IN' input sockets (24) can be used for multichannel connection.

When '3 x STEREO' is selected the 'L/R', 'SL/SR' and 'C/SUB' sockets (24) can be used for 3x stereo connection (CD IN, CDR-IN and AUX IN).

M(ultichannel) Subw(oofer) (Gain)

Analogue multichannel source devices may require different subwoofer gain depending on the bass management.

Four values can be set for this: 0.0 dB, +5.0 dB, +10.0 dB and +15.0 dB.

Rec(ord) Audio

In case one of the following analogue audio input sockets is connected to a recording device, this socket needs to be selected when making a recording:

AUDIO:TV IN, GAME IN, DVD IN (25), M-CH IN, CD IN, CD-R IN, AUX IN (24). This will avoid the recording device from putting its audio input signal directly into the output socket it is connected to (audio feedback loop) which could harm your audio equipment.

Digital out

'Raw': The digital input signal will be put out unmodified in its native form. Only select this setting if your recording device can handle multichannel input. For this, refer to the Instructions for Use of your recording device.

'PCM': Pulse Code Modulation. Select PCM for digital recording.

Language

Selects the desired system menu language. Also see 'Selecting your system menu language' in '6. Setting up the receiver'.

Reset All

Resets all 'System menu' settings to the default factory settings.



Test tone

L(ef)t Volume

R(ight) Volume

C(entre) Volume

S(urround) L(ef)t Vol(ume)

S(urround) R(ight) Vol(ume)

S(urround) B(ack) Vol(ume)

Sub(woofer) Vol(ume)

LFE Vol(ume)

Default



L(ef)t + R(ight) size

C(entre) size

Surr(ound) size

Surr(ound) Back

Sub(woofer)

Cut off

10.2 Balance menu

In the 'Balance' menu you can set the volume for the various speakers connected. You can also activate a test tone which can be used to obtain the correct balance between the volume levels of the speakers. The selected speaker will be indicated in the right display. Also see 'Setting the speaker volume' in '6. Setting up the receiver'.

Allows setting the correct volume level of the six channels with help of a noise signal. Selecting 'On' immediately starts the test tone. Pressing ◀ (6) will stop the test tone automatically.

Sets the volume of the front left speaker from - 10 dB to + 10 dB.

Sets the volume of the front right speaker from - 10 dB to + 10 dB.

Sets the volume of the centre speaker from - 10 dB to + 10 dB.

Sets the volume of the surround left speaker from - 10 dB to + 10 dB.

Sets the volume of the surround right speaker from - 10 dB to + 10 dB.

Sets the volume of the surround back speaker from - 10 dB to + 10 dB.

Sets the volume of the subwoofer from - 10 dB to + 10 dB.

Sets the low frequency effect volume from - 10 dB to 0 dB.

Selects the default factory volume settings for all speakers (0 dB).

10.3 Speakers menu

In the 'Speaker' menu you can let the receiver know how many speakers are connected and how big they are by setting the speaker size and distance. The selected speaker will be indicated in the right display. Also see 'Setting the speaker size and distance' in '6. Setting up the receiver'. Some combinations of speaker size settings are not allowed. If this is the case the respective values will be greyed out.

Selects the front left and right speaker size: 'Large' or 'Small'.

Selects the centre speaker size: 'Large', 'Small' or 'None'.

Selects the surround left and right speaker size: 'Large', 'Small' or 'None'.

Selects whether a surround back speaker is available ('Yes' or 'No') or a passive subwoofer is connected ('Subwoofer').

'No': No subwoofer connected.

'Yes': Subwoofer connected. In case 'small' speakers are connected, the subwoofer will reproduce the the bass tones of the 'small' speakers and the LFE channel.

'Always': Subwoofer connected. The subwoofer will reproduce the the bass tones of all speakers ('small' and 'large') and the LFE channel.

Determines the cutoff (crossover) frequency of 'small' speakers and subwoofer. Please refer to the Instructions for Use of your speaker system for more detailed setup information.

L(ef) + R(ight) Dist(ance)

Selects the front left and right speaker distance from 1 to 10 metre.

C(entre) Distance

Selects the centre speaker distance from 1 to 10 metre.

S(urround) L(ef) + S(urround) R(ight) Dist(ance)

Selects the surround left and right speaker distance from 1 to 10 metre.

S(urround) B(ack) Dist(ance)

Selects the surround back speaker distance from 1 to 10 metre.

Default

Selects the default factory speaker size and distance settings for all speakers.



Autoprogram

Automatically searches and stores up to 40 radio stations in FM, and MW mode.

Set Presets

For (manual) assignment of preset numbers to stored radio stations in FM and MW mode. Up to 40 preset numbers are available.

Move Preset

Swaps a preset radio station to another location (stores it under another preset number).

DAB Scan

Searches and stores DAB radio stations.

- Select 'NEW' to search and store the DAB radio stations.
- Select 'APPEND' to add new stations to the ones already stored without deleting already stored stations

DAB Move

Swaps a DAB radio station to another location in the data base (stores it under another preset number).

10.4 Tuner menu

In the 'Tuner' menu you can select and program radio stations in FM, FM-M, MW and DAB mode. Also see '8. Operating the tuner'.



Brightness

Contrast

Saturation

TV Out

HDMI Out

TV Shape

Sharpness

Hue (NTSC signal only)

Default

10.5 Picture menu

In the 'Picture' menu you can adjust picture settings for the TV.

For some picture settings ('Brightness', 'Contrast', 'Saturation', 'Sharpness' and 'Hue') the effect of the setting can directly be seen on the TV screen. These settings have an extra menu level, indicated by the highlighted ► icon at the bottom of the TV screen and the lit ► icon in the middle display, allowing you to adjust the value using ▲ and ▼ (2). Confirm the adjustment with OK (4) or press ◀ to go back to the previous level without storing the adjustment.

Adjust the brightness of the displayed picture (0 - 100).

Adjusts the overall contrast intensity from (0 - 100).

Adjusts the colour saturation of the projected image (0 - 100).

Selects resolution and mode for the TV outputs (22): 576i RGB, 576p YPbPr, 720p YPbPr, 1080i YPbPr.

Selects resolution and mode for the HDMI output (27): Auto, 576p, 720p, 1080i, VGA, SVGA, XGA, SXGA. Items that are not supported by your TV monitor are greyed out.

Selects the picture format for the displayed picture on the TV screen: 'Auto', '4:3', '16:9'.

Controls the contour impression of the displayed picture (0 - 100).

Adjusts the tint of the projected image (0 - 100).

Resets all 'Picture' settings to the default factory settings.



DCDI (NTSC signal only)

Cross Colour

True Life

Blue Extend

Green Extend

Skin Tone

Black Level

DNR

Default

10.6 Enhancement menu

In the 'Enhancement' menu you can set the TV to adjust settings automatically.

DCDI (Directional Correlational Deinterlacing), eliminates the jagged edges that appear when standard interlaced video is viewed on progressive scan displays (On/Off).

Prevents colours being displayed in the wrong places (On/Off).

Enhances details in an image such as skin texture, freckles or hair; thus making them more visible and more lifelike. 'True Life' also enhances large edges to create greater depth of perception. (Off/1-8.)

Enhances the blue colours in the projected image. Makes the colours more vivid and improves the resolution of details. (Off/1-4.)

Enhances the green colours in the projected image. Makes the colours more vivid and improves the resolution of details. (Off/1-4.)

Adjusts the colour spectrum of human skin displayed on the TV screen (Off/1-4).

Adjust the brightness (black level) of the displayed picture (On/Off).

Dynamic Noise Reduction. Improves the video image quality by removing signal distortions (On/Off).

Resets all 'Enhancement' settings to the default factory settings.



10.7 A/V input menu

In the 'A/V input' menu you can (re)assign input sockets for connection to a specific A/V device. If 'None' is selected, the connected source will not be recognized by the Source selection buttons (2 and 4) and the source will not be shown on the display. Also see 'Rear view' in '3.2 Rear view' and 'Reassigning input sockets in '6.7 Setting up the receiver'.

SACD Video

For SACD video equipment, the HDMI 1 input socket (27) is assigned. Other input sockets that can be assigned for connection to SACD equipment are: HDMI IN 2 (27), VIDEO 1 IN (19), VIDEO 2 IN (20), TV IN (21), GAME IN (21) and DVD IN (21).

SACD Audio 1

For SACD equipment, the M-CH IN input sockets (24) are assigned. Other input sockets that can be assigned for connection to SACD equipment are: OPTICAL IN (23), DIGITAL IN 1 (28), DIGITAL IN 2 (28), DIGITAL IN 3 (28), HDMI IN 1 (27), HDMI IN 2 (27), CD IN (24), CD-R IN (24), AUX IN (24), TV IN (25), GAME IN (25), DVD IN (25).

SACD Audio 2

For an HDMI enabled SACD device, the HDMI 1 input socket (27) is assigned. Other input sockets that can be assigned for connection to an HDMI enabled SACD device are: M-CH IN (24), OPTICAL IN (23), DIGITAL IN 1 (28), DIGITAL IN 2 (28), DIGITAL IN 3 (28), HDMI IN 1 (27), HDMI IN 2 (27), CD IN (24), CD-R IN (24), AUX IN (24), TV IN (25), GAME IN (25), DVD IN (25).

DVD Video

For video signal from a DVD player/recorder, the following input socket is assigned: VIDEO 1 IN (19). Other input sockets that can be assigned for DVD video signal input are: HDMI IN 1 (27), HDMI IN 2 (27), VIDEO 2 IN (20), TV IN (21), DVD IN (21), GAME IN (21).

DVD Audio

For audio signal from a DVD player/recorder, the DIGITAL IN input socket (28) is assigned. Other input sockets that can be assigned for DVD audio signal input are: M-CH IN (24), OPTICAL IN (23), DIGITAL IN 1 (28), DIGITAL IN 2 (28), DIGITAL IN 3 (28), HDMI IN 1 (27), HDMI IN 2 (27), CD IN (24), CD-R IN (24), AUX IN (24), TV IN (25), GAME IN (25), DVD IN (25).

Sat(ellite) Video

For video signal from a satellite receiver, the following input socket is assigned: VIDEO 2 IN (20). Other input sockets that can be assigned for video signal input of a satellite receiver are: HDMI IN 1 (27), HDMI IN 2 (27), VIDEO 1 IN (19), TV IN (21), GAME IN (21), DVD IN (21).

Sat(ellite) Audio

For audio signal from a satellite receiver, the OPTICAL IN input socket (23) is assigned. Other input sockets that can be assigned for audio signal input of a satellite receiver are: M-CH IN (24), DIGITAL IN 1 (28), DIGITAL IN 2 (28), DIGITAL IN 3 (28), HDMI IN 1 (27), HDMI IN 2 (27), CD IN (24), CD-R IN (24), AUX IN (24), TV IN (25), GAME IN (25), DVD IN (25).

TV Video

For video signal from a TV, the TV IN input sockets (21) are assigned. Other input sockets that can be assigned for video signal input of a TV are: HDMI IN 1 (27), HDMI IN 2 (27), VIDEO 1 IN (19), VIDEO 2 IN (20), GAME IN (21), DVD IN (21).

TV Audio

For audio signal from a TV, the TV IN input sockets (25) are assigned. Other input sockets that can be assigned for audio signal input of a TV are: M-CH IN (24), OPTICAL IN (23), DIGITAL IN 1 (28), DIGITAL IN 2 (28), DIGITAL IN 3 (28), HDMI IN 1 (27), HDMI IN 2 (27), CD IN (24), CD-R IN (24), AUX IN (24), TV IN (25), GAME IN (25), DVD IN (25).

Game Video

For video signal from a game console, the GAME IN input sockets (21) are assigned. Other input sockets that can be assigned for video signal input of a game console are: HDMI IN 1 (27), HDMI IN 2 (27), VIDEO 1 IN (19), VIDEO 2 IN (20), TV IN (21), DVD IN (21).

Game Audio

For audio signal from a game console, the GAME IN input sockets (25) are assigned. Other input sockets that can be assigned for video signal input of a game console are: M-CH IN (24), OPTICAL IN (23), DIGITAL IN 1 (28), DIGITAL IN 2 (28), DIGITAL IN 3 (28), HDMI IN 1 (27), HDMI IN 2 (27), CD IN (24), CD-R IN (24), AUX IN (24), TV IN (25), GAME IN (25), DVD IN (25).

DVD + RW Video

For video signal from a DVD player/recorder, the following input socket is assigned: DVD IN (21). Other input sockets that can be assigned for video signal input of DVD player/recorder are: HDMI IN 1 (27), HDMI IN 2 (27), VIDEO 1 IN (19), VIDEO 2 IN (20), TV IN (21), GAME IN (21).

DVD + RW Audio

For audio signal from a DVD player/recorder the following input socket is assigned: DVD IN (25). Other input sockets that can be assigned for audio signal input of DVD player/recorder are: M-CH IN (24), OPTICAL IN (23), DIGITAL IN 1 (28), DIGITAL IN 2 (28), DIGITAL IN 3 (28), HDMI IN 1 (27), HDMI IN 2 (27), CD IN (24), CD-R IN (24), AUX IN (24), TV IN (25), GAME IN (25), DVD IN (25).

HDTV Video

For video signal from an HDMI source device, the HDMI IN 2 input socket (27) is assigned. Other input sockets that can be assigned for video signal input of an HDMI source device are: HDMI IN 1 (27), VIDEO 1 IN (20), VIDEO 2 IN (20), TV IN (21), GAME IN (21), DVD IN (21).

HDTV Audio

For audio signal input of an HDMI source device, the HDMI IN 2 input socket (27) is assigned. Other input sockets that can be assigned for audio signal input of an HDMI source device are: M-CH IN (24), OPTICAL IN (23), DIGITAL IN 1 (28), DIGITAL IN 2 (28), DIGITAL IN 3 (28), HDMI IN 1 (27), CD IN (24), CD-R IN (24), AUX IN (24), TV IN (25), GAME IN (25), DVD IN (25).

CD Audio

For audio signal from a CD player, the DIGITAL IN 2 (28) is assigned. Other input sockets that can be assigned for audio signal input of a CD player are: M-CH IN (24), OPTICAL IN (23), DIGITAL IN 1 (28), DIGITAL IN 3 (28), CD IN (24), CD-R IN (24), AUX IN (24), TV IN (25), GAME IN (25), DVD IN (25).

CD-R Audio

For audio signal from a CD recorder, the DIGITAL IN 2 (28) is assigned. Other input sockets that can be assigned for audio signal input of a CD recorder are: M-CH IN (24), OPTICAL IN (23), DIGITAL IN 1 (28), DIGITAL IN 3 (28), CD IN (24), CD-R IN (24), AUX IN (24), TV IN (25), GAME IN (25), DVD IN (25).

AUX Audio

The following input sockets can be assigned for connection to auxiliary audio equipment. M-CH IN (24), OPTICAL IN (23), DIGITAL IN 1 (28), DIGITAL IN 2 (28), DIGITAL IN 3 (28), CD IN (24), CD-R IN (24), AUX IN (24), TV IN (25), GAME IN (25), DVD IN (25).



10.8 Gain menu

In the 'Gain' menu you can amplify the analogue input signal when the signal itself is too low to lead to a full scale output.

Max(imum) Volume

Safety feature to limit sound pressure (-1 dB – -30dB).

M-CH(annel) In

Amplifies the volume of the device connected to the M-CH IN input sockets (24) (+0 dB – +12dB).

CD In

Amplifies the volume of a CD player connected to one of the input sockets, assigned for connection to a CD player (+0 dB – +12dB).

CD-R In

Amplifies the volume of a CD player/recorder connected to one of the input sockets, assigned for connection to a CD player/recorder (+0 dB – +12dB).

AUX In

Amplifies the volume of auxiliary audio equipment connected to one of the input sockets, assigned for connection to auxiliary audio equipment (+0 dB – +12dB).

TV In

Amplifies the volume of a TV connected to one of the input sockets, assigned for connection to a TV (+0 dB – +12dB).

Game In

Amplifies the volume of a game console connected to one of the input sockets, assigned for connection to a game console (+0 dB – +12dB).

DVD In

Amplifies the volume of a DVD player/recorder connected to one of the input sockets, assigned for connection to a DVD player/recorder (+0 dB – +12dB).

Default

Resets all 'Gain' settings to the default factory settings (0 dB).

11. Troubleshooting

WARNING

Under no circumstances should you try to repair the set yourself as this will invalidate the guarantee. Do not open the set as there is a risk of electric shock.

If you need any support:

- 1) check the points listed below;*
- 2) visit <http://www.philips.com/support> for online support;*
- 3) call our help line (see page 63).*

Receiver problems	Possible cause	Solution
No power, even when  STANDBY ON is pressed.	Mains lead not (properly) connected.	(Properly) connect the mains lead.
Volume turns down automatically/sound switches off completely.	Set became too hot.	Wait until set has cooled down.
Display does not light up.	Display brightness has been set to 0.	Increase display brightness with DIM (22) on the remote control.
Receiver goes to standby automatically (Standby LED) flashes and cannot be activated again.	Internal overheating.	<p>Move the receiver away from the heat sources (or vice versa).</p> <p>Make sure nothing is placed on top of the receiver.</p> <p>Make sure the receiver is not placed on top of equipment that might heat up (e.g. another receiver or amplifier).</p> <p>Make sure all air inlets and outlets are clear from obstructions.</p>
Remote control problems	Possible cause	Solution
No reaction on remote control commands.	Batteries not properly inserted.	Insert batteries properly.
	Distance to DFR9000 too great.	Reduce distance.
	Wrong remote control mode.	Use SELECT (3) to select RECVR.
Remote control mode does not light up in status window (3).	Batteries exhausted.	Replace batteries.
Speaker problems	Possible cause	Solution
Poor sound or no sound at all from one or more speakers.	Speaker(s) not (properly) connected.	Connect speaker(s) properly. See '4.8 Connecting the speakers'.
	Speaker size, distance and/or volume not properly set.	(Properly) set speaker size, distance and/or volume. See '6.4 Setting the speaker size and distance' and '6.5 Setting the speaker volume'.
	'Mute' (11) activated.	Disable 'Mute' (11).
	Speaker size set to 'None' in 'Speaker' menu.	Select correct speaker size. See '6.4 Setting the speaker size'.
Reversed left and right sound.	Speakers not properly connected.	Connect speakers properly. See '4.8 Connecting the speakers'.
Sound level of one or more speakers is too high or too low.	Sound level not (properly) adjusted.	(Properly) adjust sound level of the speaker(s). See '6.5 Setting the speaker volume'.

Poor bass sound.	Speakers are not in phase.	Connect the coloured (or marked) wires to the coloured terminals and the black (or unmarked) wires to the black terminals.
------------------	----------------------------	--

Poor response of subwoofer.	Subwoofer positioned too close to the middle of the room.	Position subwoofer closer to a corner.
-----------------------------	---	--

Video problems	Possible cause	Solution
-----------------------	-----------------------	-----------------

No picture.	A/V input channel not selected on TV.	Check the Instructions for Use of your TV for the correct A/V input channel.
	TV not switched on.	Switch on your TV.
	Wrong video input connected to source.	Make proper video connection.

No picture after setting resolution in 'Picture' menu ('TV out').	TV does not support selected resolution.	Undo setting via local (middle) display and select another resolution. See '10.5 Picture menu' ('TV out'). If possible, connect TV to CVBS OUT (22) or make an S-Video connection via REC OUT (21).
---	--	--

No picture on TV when selecting a source, using VIDEO 1 IN(19) or VIDEO 2 IN (20).	The source device only delivers CVBS and no RGB signal.	Connect the yellow cinch cable of the 6-cinch + Scart control to Scart cable to TV IN (21), GAME IN (21) or DVD IN (21),and switch to a source using one of these inputs.
--	---	---

Tuner problems	Possible cause	Solution
-----------------------	-----------------------	-----------------

Bad radio reception, automatic programming does not work properly.	Your DFR9000 or the antenna is positioned near a radiation source such as a TV, CD player; CD recorder; DVD player; etc.	Change the position of the interfering source or switch it off.
	Weak antenna signal.	AM: rotate the antenna for best reception. FM/FM-M/MW: try to optimize reception with the ◀◀ or ▶▶ buttons (8).

Poor or disturbed radio reception or no reception at all in DAB mode.	DAB antenna not properly placed.	Vary the position and direction of the antenna until you find the strongest reception and then secure the antenna in that position.
	Antenna supplied not strong enough for receiving DAB signals.	Have a dedicated DAB antenna installed.

Intermittent buzzing in tuner.	Local interference.	Move your DFR9000 or antenna away from computers, fluorescent lights, motors or other electrical appliances.
--------------------------------	---------------------	--

Playback problems	Possible cause	Solution
A source is selected but no sound is heard.	Volume at minimum level.	Adjust the volume.
	Source not connected to correct input socket or input socket is reassigned for another source.	Check if source is connected to correct input socket or reassign the input socket.
	Headphones are connected.	Disconnect headphones.
	Wrong source selected.	Select correct source.
	'Mute' (11) activated.	Disable 'Mute' (11).
	Source is not playing.	Start playback on source.
Speakers are not (properly) connected.	Connect speakers (properly).	
A connected source cannot be selected.	Audio and video for the source are set to 'None' in the 'A/V input' menu.	Select (assign) input socket(s) for the source. See '10.7 A/V input menu'.
No digital surround sound available.	The inserted disc or the selected source does not support digital surround sound.	Use another disc or select another source.
	No surround mode selected.	Select surround mode. See '9. Surround modes'.
No sound or poor sound when playing SACDs on your SACD player (or other analogue multichannel source device).	Speaker settings of source device and receiver not the same.	Make sure speaker setup of source device is the same as receiver speaker setup.
No sound or poor sound when playing regular CDs or DVDs on your SACD player (or other analogue multichannel source device).	Receiver outputs the signal via the wrong outputs.	Make an additional audio connection so receiver can use this connection to output the CD/DVD signal.
Recording problems	Possible cause	Solution
Recording from a specific recording device not possible (<i>only valid for audio sources</i>).	Wrong input socket selected in 'Configuration' menu.	Select input socket to which recording devices' output socket is connected. See '7.5 Selecting input sockets for recording' and '10.1 Configuration menu', sub-menu 'Rec audio'.
No digital recording possible via DIGITAL OUT (28).	The sampling frequency is not accepted by the digital recording device.	Make sure the digital recording device can handle sampling frequencies between 32 kHz and 48 kHz or make the recording via one of the analogue outputs.
	Content copy protected.	
Whole recording appears as one track when recording from DVD disc.	The DVD player does not provide track information.	Record each track individually.

12. Glossary

AM	Amplitude Modulation. A method of radio transmission, by which the information part of the signal causes the amplitude to vary without affecting the frequency.
Amplifier	An electronic device that takes in an original signal, gives it more power and provides it as an output.
Analogue	A continuously varying action, or movement that takes time to change from one position to another. Standard audio and video signals are analogue. An analogue signal has an infinite number of levels between its highest and lowest value. (Not like digital, where changes are by steps.)
A/V input	Allows input of Audio/Video signals.
Balance	Adjusts the relative volume levels of left and right channels for optimal stereo effect. Compensates for channel imbalance and non-symmetrical loudspeaker positioning
Bandwidth	A frequency range, or 'band' of frequencies between the limits defined by the 'half power points', where the signal loss is -3dB. In audio and video, it is this band of frequencies that can pass through a device without significant loss or distortion. The wider the bandwidth, the better the quality that results, such as a sharper picture, better sound, etc. The higher the bandwidth number the better the performance (300 MHz is better than 250 MHz). When a signal passes through a path with more than one device (including cables) the limiting factor (bottleneck) in that path is the device with the narrowest bandwidth.
Bass	The lower range of audio frequencies, up to approximately 500 Hz.
Black level	More commonly referred to as 'brightness', the black level is the level of light produced on a video screen.
Copy protection	Copy protection is a technical protection measure designed to prevent duplication of copyrighted works.
CVBS	CVBS stands for 'Composite video, blanking, and sync'. A standard video signal as output by VCRs and satellite receivers. CVBS combines the colour, luminance and synchronization information in one signal. The audio signal is transferred separately.
DAB	Digital Audio Broadcast. DAB is a terrestrial digital broadcasting standard which is recognized by the IUT (International Union for Telecommunications). The use of proper DAB frequencies (Band III and L-Band) allows a good quality transmission. DAB programs are broadcast inside a multiplex which is composed of six to ten radio stations on a single frequency. DAB can carry not only audio but also PAD (Program Associated Data) or NPAD (Non Program Associated Data) such as text, pictures, data and even videos: it is then called DMB (Digital Multimedia Broadcasting).
dB	Decibel. The minimum change in sound intensity that a human ear can distinguish. A doubling of volume is a 10 dB increase. To double volume in a stereo system, a 10-fold increase in power output (WATTS) is required.
DCDi™	DCDi™ by Faroudja. stands for Directional Correlation Deinterlacing and is a package of picture innovations that digitally adjusts and optimizes picture quality to optimal contrast, colour and sharpness level.
Digital	A system of data or image values in the form of discrete, non-continuous codes, such as binary. When data is in a digital format, it can be processed, stored (recorded) and reproduced easily while maintaining its original integrity.
DLS	Dynamic Label Service. Radio text information, provided by DAB radio stations.
Dolby® Surround Sound	Dolby Stereo is the name given to the four-channel surround sound developed by Dolby Laboratories and introduced into movie theaters in the 70s. It employed a matrix encoding scheme called Dolby Surround which recorded four channels of information on two channels. The two channels are decoded into L, R, Center and Surround upon playback. The centre channel is recorded identically on the left and right channels. Also see '9. Surround modes'.
DTS Digital Surround	DTS: abbreviation for Digital Theater System. Like Dolby Digital, DTS is another 5.1-channel surround sound format that is available in movie theaters, and as an optional soundtrack on some DVD-Video movies for home theatre viewing. DTS is not a standard soundtrack format for DVD-Video, and is not used by HDTV or digital satellite broadcasting. Also see '9. Surround modes'.

DVD	Digital Versatile Disc. An optical disc about the size of a CD-ROM, but capable of storing an entire movie. The technology uses MPEG-2 compression. Typical capacity for these discs is 4.5 GB, or about 133 minutes of digital video. Originally called 'Digital Video Disk'.
DVI	DVI (Digital Video Interface) is a new form of video interface technology made to maximize the quality of flat panel LCD monitors and high-end video graphics cards. DVI is also a digital transfer method for HDTV, EDTV, Plasma Display, and other ultra-high-end video displays for TV, movies, and DVDs.
FM	Frequency Modulation. A method of combining an information signal with a carrier signal so that it may be transmitted. FM radio is frequency modulated. Audio is encoded on the carrier by varying the frequency in response to the audio.
Frequency	The number of complete cycles per second of a musical tone or electronic signal, expressed in Hertz (Hz).
Frequency response	The frequency range in which an electronic component can accurately reproduce its input. Humans can hear from 20 Hz to 20,000Hz (20kHz). An ideal component would have a Frequency Response, totally flat or without any deviation, from 20Hz to 20 kHz. Frequency Response specifications are measured in dB based on how closely a component's response resembles that of the ideal.
Gain	A general term for an increase in signal power or voltage produced by an amplifier.
HDCP	Your DFR9000 supports High bandwidth Digital Content Protection (HDCP), owned by Intel.
HDMI	High Definition Multimedia Interface. A specification developed by the HDMI Working Group that combines multi-channel audio and high definition video and that controls signals into a single digital interface for use with DVD players, digital television, and other audiovisual devices.
HDTV	High Definition Television. HDTV refers to a complete product/system with the following minimum performance attributes: a receiver that receives ATSC terrestrial digital transmissions and decodes all ATSC Table 3 video formats; a display scanning format with active vertical scanning lines of 720 progressive (720p), 1080 interlaced (1080i), or higher; aspect ratio capabilities for displaying a 16:9 image; receives and reproduces, and/or outputs Dolby Digital audio.
Hertz (Hz)	The basic unit of frequency. One hertz equals one cycle per second.
Image	A reproduction or imitation of a person or thing displayed by any type of visual media.
Interlacing	A video frame is made up of two fields. Interlacing is the process of scanning the picture onto a video screen whereby the lines of one scanned field fall evenly between the lines of the preceding field.
LED	Light emitting diode. A low-power, long life, light source, usually red, green or yellow in color. Some LEDs can produce two different colors.
Level	The relative intensity of an audio or video source.
LFE	Low Frequency Effects channel. A special channel of 5 to 120Hz of information intended for special effects such as explosions in movies. The LFE channel has an additional 10 dB headroom in order to accommodate the required level.
Line out	Audio output, typically in level range of 1-2 Volts. This may be 10,000 -50,000 ohms, at -10dB or -20dB.
L/R Audio	This abbreviation stands for Left and Right audio.
Macrovision	Macrovision provides licensing and copy protection solutions for the video, music, software and hardware industries.
Modulation	The process of adding an information signal to a carrier frequency to allow it to be transmitted. Thus, the carrier is 'modulated' by the information signal, as in a modem.
Multichannel	DVDs are formatted to have each sound track constitute one sound field. Multichannel refers to a structure of sound tracks having three or more channels.

NSV™	Noise Shaped Video. NSV™ is a new video format. It is designed to be easily streamed, support any audio and video codec, and be usable on nearly any platform. Currently NSV™ utilizes MP3 for audio and VP3 for video.
NTSC	National Television Standards Committee. The television standard for North America and parts of South America having 525 lines/60 Hz (60 Hz refresh), two fields per frame and 30 frames per second. Technically, NTSC is a color modulation scheme. To fully specify the color video signal it should be referred to as (M) NTSC. NTSC is also commonly (though incorrectly) used to refer to any 525/59.94 video system. See (M)NTSC.
Ohm	The unit of electrical resistance, transmitting a current of 1 amp when subjected to a potential difference of 1 volt.
PCM	Pulse Code Modulation is a digital scheme for transmitting analogue data. PCM makes it possible to digitize all forms of analogue data, including full-motion video, voices and music.
Phase	The relative timing of one signal to another, usually expressed in degrees of shift.
Radio frequency (RF)	A range of frequencies used for electromagnetic transmission (e.g. radio and TV).
RDS	Radio Data System is a service that allows FM stations to send additional information. If you are receiving an RDS station, RDS and the station name are displayed.
RGB	Red, green and blue. The basic components of the colour television system. They are also the primary colours of light in the 'additive colour process'.
RGBS	The red, blue, and green chroma information in a video signal, with a separate channel for the sync signal.
Satellite receiver	A receiver designed for satellite reception system, which receives modulated signals from an LNA (Low Noise Amplifier;) or LNB (Low Noise Block Downconverter;) and converts them into their original form suitable for direct presentation to the user.
Saturation	The intensity of the color; or the extent to which a given color in any image is free from white. The less white in a color, the truer the color; or the greater its saturation.
Surround Sound	A system of audio reproduction that uses four or more speakers to simulate the full three-dimensional effect of a live musical performance or cinematic environment. (See also 'Dolby Pro-Logic® Surround Sound').
S-video	A composite video signal separated into the luma ('Y' is for luma, or black and white information; brightness) and the chroma ('C' is an abbreviation for chroma, or color information).
Sync	Synchronization. In video, sync is a means of controlling when things happen with respect to other things. This is accomplished with timing pulses to insure that each step in a process occurs at exactly the right time. For example, horizontal sync determines exactly when to begin each horizontal line (sweep) of the electron beam. Vertical sync determines when to bring the electron beam to the top left of the screen to start a new field. There are many other types of sync in a video system. Also called 'sync signal' or 'sync pulse'.
Test Tone	Dolby Pro-Logic® Surround Sound receivers offer this feature to allow individual adjustment of all channels according to your listening (viewing) location and individual preference. To set the balance, a test tone is sent to each channel in a repeating cycle.
Toggle	To switch between alternate states. For example: between on and off.
Tuner	Radio receiver.
UCD	User Centered Design. A method for designing ease-of-use into the total user experience with products.
VCR	Generally defined as video cassette recorder.
Watt	A unit of electrical power used to indicate the rate of energy produced or consumed by an electrical device. One watt is one joule of energy per second.

13. Technical specifications

Audio section

Power amplifier	<p>Rated RMS output: 2 x 110 W (4 ohm, 1 kHz with 1% Total Harmonic Distortion) 6 x 65 W (4 ohm, 1 kHz with 1% Total Harmonic Distortion)</p> <p>Dynamic power: 2 x 130 W (4 ohm) 6 x 90 W (4 ohm)</p> <p>Maximum power: < 190 W per channel</p> <p>Signal-noise: 105 dBA</p> <p>Frequency response: 5 Hz - 45 kHz</p> <p>Output terminals: 4 - 8 ohm</p> <p>Total Harmonic Distortion 1 W - 1 kHz: 0.065 %</p>
Digital output	Coaxial out according IEC 60958 & IEC 61937 / 0.5 Vpp / 75 ohm / PCM/Dolby Digital/DTS up to 96kHz
Digital input	Optical and coaxial in according IEC 60958 & IEC 61937 / > 0.2 Vpp / 75 ohm / 32-96kHz, 24 bit PCM / DTS / DTS96/24 / Dolby Digital Multichannel formats: Dolby Prologic IIx, Dolby Digital, Dolby Digital EX, DTS, DTS 96/24, DTS ES Matrix, DTS ES Discrete, DTS NEO:6.
Line/Rec out	<p>Rated output: 1.6 Vrms</p> <p>Signal-noise: 110 dBA</p> <p>Total Harmonic Distortion: 0.0016 %</p> <p>Frequency response: 5 - 100 kHz</p> <p>Input sensitivity: 0.2 - 2.8 V</p> <p>Input impedance: 22 kohm</p> <p>ADC/DAC rated output: 96 kHz / 24 bits</p>

Analogue video section (input/output)

Composite Video	<p>Signal level: 1 Vp-p/75 ohm</p> <p>Frequency response: 0-6 Mhz</p> <p>Signal-noise: > 50 dB</p>
S-Video	<p>Signal level: Y - 1 Vp-p / 75 ohm C - 0.286 Vp-P / 75 ohm</p> <p>Frequency response: 0 - 6.5 MHz</p> <p>Signal-noise: > 65 dB</p>
Component Video/RGB	<p>Signal level:</p> <p>Y - 1 Vp-p / 75 ohm</p> <p>PB/CB, PR/CR - 0.7 Vp-p / 75 ohm</p> <p>R, G, B - 0.7 Vpp / 75 ohm</p> <p>Frequency response: 0 - 7 MHz</p> <p>Progressive: 0 - 16 MHz</p> <p>Signal-noise: > 70 dB</p>
Input resolutions/formats	<p>PAL: 576i (720 x 576i)</p> <p>PAL progressive: 576p (720 x 576p, downscaled to 576i)</p> <p>NTSC: 480i (720 x 480i)</p> <p>NTSC progressive: 480p (720 x 480p, downscaled to 480i)</p>
Input resolution	<p>PAL input 50 Hz (TV):</p> <ul style="list-style-type: none"> - 576i (720 x 576i); - 576p (720 x 576p); - 720p (1280 x 720p); - 1080i (1920 x 1080i). <p>NTSC input 60 Hz (TV):</p> <ul style="list-style-type: none"> - 480i (720 x 480i); - 480p (720 x 480p); - 720p (1280 x 720p); - 1080i (1920 x 1080i).

Digital video section (input/output)**'Source only' mode**

According HDMI 1.1, HDCP 1.1 and DVI 1.0 standards.
Following formats are supported:

50 Hz (TV):

- 576p (720 × 576p) - EIA/CEA-861B format # 17, 18;
- 720p (1280 × 720p) - EIA/CEA-861B format # 19;
- 1080i (1920 × 1080i) - EIA/CEA-861B format # 20.

60 Hz (TV):

- 480p (720 × 480p) - EIA/CEA-861B format # 2, 3;
- 720p (1280 × 720p) - EIA/CEA-861B format # 4;
- 1080i (1920 × 1080i) - EIA/CEA-861B format #5.

60Hz (PC):

- VGA (640 × 480p);
- SGVA (800 × 600p);
- XGA (1024 × 768p);
- SXGA (1280 × 1024p).

'Repeater' mode

All modes are supported (up to 1080i, SXGA)

Audio over HDMI

PCM (32 kHz, 44.1 kHz, 48 kHz), Dolby Digital or DTS digital audio transmission at a sample rate of 32-96 kHz Fs

Tuner**Tuner bands**

FM, FM-Mono, MW, DAB

FM Tuner

Frequency range: 87.5-108 MHz
Antenna input: 75 ohm

MW Tuner

Frequency range: 531 kHz - 1602 kHz
Antenna input: 300 ohm

DAB Tuner

Band: III (174-240 MHz) + L (1452-1492 MHz)
Antenna input: 50 ohm
DLS (Dynamic Label Service) radio text support via on screen display

General

HDMI: Compatible with DVI 1.0 (HDCP) devices
Power requirements: AC 220-230V, 50/60 Hz
Power consumption: 130 W typical at 1/8 P rated
In standby: 0.48 W
Dimensions: 435 × 380 × 95 mm
Weight (without package): 7 kg

Specifications are subject to change without notice, due to improvements.

Helpline

PHILIPS AUSTRIA GMBH
Triesterstrasse 64
1101 Wien
AUSTRIA
Tel: 0810 00 12 03

ΦΙΛΙΠΣ ΕΛΛΑΣ ΑΕΒΕ
25ΗΣ ΜΑΡΤΙΟΥ 15
177 78 ΤΑΥΡΟΣ
ΑΘΗΝΑ
Τηλ. 0 0800 312 212 80

PHILIPS POLSKA AL.
Jerozolimskie 195B
02-222 Warszawa
POLSKA
Tel.: (022)-571-0-571

PHILIPS CUSTOMER CARE CENTER
Twee Stationsstraat 80
80 Rue des Deux Gares
1070 BRUSSEL/BRUXELLES
BELGIUM (for BENELUX)
Tel: 070-222 303

PHILIPS MÁRKASZERVIZ
Kinizsi U 30-36
Budapest 1119
HUNGARY
Phone: (01)-382 1700

PHILIPS REPRESENTATION OFFICE
Ul. Usacheva 35a
119048 MOSCOW
RUSSIA
Phone: 095-937 9300

PHILIPS SERVICE
V Mezihori 2
180 00 Prague
CZECH REPUBLIC
Phone: (02)-3309 330

**PHILIPS ELECTRONICS
IRELAND LIMITED**
Consumer Information Centre
Newstead, Clonskeagh
DUBLIN 14
Phone: 01-764 0292

PHILIPS Iberia, S.A.
C/Martinez Villergas, 49
28027 MADRID
SPAIN
Phone: 902-113 384

PHILIPS KUNDECENTER
Frederikskaj 6,
DK-1780 København V
DENMARK
Tlf: 808 82 814

PHILIPS CONSUMER ELETRONICS
Servizio Consumatori
Via Casati 26
20052 Monza - Milano
ITALY
Phone: 199 11 88 99

PHILIPS INFO CENTER
Fegistrasse 5
8957 Spreitenbach
SUISSE
Tel.: 0844-800 544

OY PHILIPS AB
Sinikalliontie 3,
02630 Espo
Helsinki
FINLAND
puh. (09) 6158 0250

PHILIPS CONSUMENTENLIJN
t.a.v. betreffende afdeling
Postbus 102 5600 AC Eindhoven
NETHERLANDS
Phone: 0900-8406

PHILIPS KUNDTJÄNST
Kollbygatan 7,
Akalla,
16485 Stockholm
SWEDEN
Phone: 08-5985 2250

SERVICE CONSOMMATEURS
PHILIPS
BP 0101
75622 Paris Cédex 13
FRANCE
Phone: 0825-88 97 89

PHILIPS NORGE AS
Sandstuveien 70,
PO Box 1, Manglerud
N-0612 Oslo
NORWAY
Tlf.: 22 748 250

TURK PHILIPS TICARET A. S.
Yukari Dudullu Organize Sanayi Bolgesi
2., Cadde No: 22
81260 Umraniye/Istanbul
Phone: 0800 261 33 02

PHILIPS INFO CENTER
Alexanderstraße 1
20099 Hamburg
GERMANY
Tel: 0180-535 6767

PHILIPS PORTUGUESA, S.A.
Consumer Information Centre
Rua Dr. António Loureiro Borge, nr. 5
Arquiparque, Miraflores
P-2795 L-A-VEHLA
PORTUGAL
Phone: 2 1416 3033

PHILIPS CE, The Philips Centre,
420 - 430 London Road,
Croydon, Surrey
CR9 3QR
UNITED KINGDOM
Phone: 0870-900-9070

www.philips.com/support

Certificat de garantie
Certificado de garantia
Εγγύηση
Garantibevís

Certificat de garantie
Certificado de garantia
Εγγύηση
Garantibevís

Garantieschein
Certificato di garanzia
Garanticertifikat
Takuutodistus

1

year warranty
année garantie
Jahr Garantie
jaar garantie
año garantia
anno garanzia

χρόνος εγγύηση
år garanti
år garanti
år garanti
vuosi takuu
año garantia

Type: **DFR9000**

Serial nr: _____

Date of purchase - Date de la vente - Verkaufsdatum - Aankoopdatum - Fecha de compra - Date d'acquisto -
Data da aquisição - Ημερομηνία αγοράς - Inköpsdatum - Anskaffelsesdato - Køpedato - Oatopäivä -

Dealer's name, address and signature
Nom, adresse et signature du revendeur
Name, Anschrift und Unterschrift des Händlers
Naam, adres en handtekening v.d. handelaar
Nombre, dirección y firma del distribuidor
Nome, indirizzo e firma del fornitore

Όνοματεπώνυμο, διεύθυνση και υπογραφή του εμπ. προμηθευτή
Återförsäljarens namn, adress och signatur
Forhandlerens navn, adresse og underskrift
Forhandlerens navn, adresse og underskrift
Jälleenmyyjän nimi, osoite ja allekirjoitus
Nome, morada e assinatura da loja

www.philips.com

This document is printed on chlorine free produced paper

Data subject to change without notice

Printed in China

3103 305 2042.1 / 31-01-2005

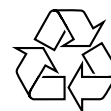

PHILIPS

Free Manuals Download Website

<http://myh66.com>

<http://usermanuals.us>

<http://www.somanuals.com>

<http://www.4manuals.cc>

<http://www.manual-lib.com>

<http://www.404manual.com>

<http://www.luxmanual.com>

<http://aubethermostatmanual.com>

Golf course search by state

<http://golfingnear.com>

Email search by domain

<http://emailbydomain.com>

Auto manuals search

<http://auto.somanuals.com>

TV manuals search

<http://tv.somanuals.com>