

Digital surround sound receiver

FR960  
FR970



*Let's make things better.*



**PHILIPS**

## Important notes for users in the U.K.

### Mains plug

This apparatus is fitted with an approved 13 Amp plug.  
To change a fuse in this type of plug proceed as follows:

- 1 Remove fuse cover and fuse.
- 2 Fix new fuse which should be a BS1362 5 Amp, A.S.T.A. or BSI approved type.
- 3 Refit the fuse cover.

If the fitted plug is not suitable for your socket outlets, it should be cut off and an appropriate plug fitted in its place. If the mains plug contains a fuse, this should have a value of 5 Amp. If a plug without a fuse is used, the fuse at the distribution board should not be greater than 5 Amp.

**Note:** The severed plug must be disposed of to avoid a possible shock hazard should it be inserted into a 13 Amp socket elsewhere.

### How to connect a plug

The wires in the mains lead are coloured with the following code: blue = neutral (N), brown = live (L).

As these colours may not correspond with the colour markings identifying the terminals in your plug, proceed as follows:

- Connect the blue wire to the terminal marked N or coloured black.
- Connect the brown wire to the terminal marked L or coloured red.
- Do not connect either wire to the earth terminal in the plug, marked E (or  $\perp$ ) or coloured green (or green and yellow).

Before replacing the plug cover, make certain that the cord grip is clamped over the sheath of the lead - not simply over the two wires.

### Copyright in the U.K.

Recording and playback of material may require consent. See Copyright Act 1956 and The Performer's Protection Acts 1958 to 1972.

## Italia

### DICHIARAZIONE DI CONFORMITA'

Si dichiara che gli apparecchi FR 960 e FR 970 Philips rispondono alle prescrizioni dell'art. 2 comma 1 del D. M. 28 Agosto 1995 n. 548.

Fatto a Eindhoven, il 01/06/1999

Philips Consumer Electronics  
Philips, Glaslaan 2  
5616 JB Eindhoven, The Netherlands

## Norge

Typeskilt finnes på apparatens bakside.

**Observer:** Nettbryteren er sekundert innkopleet. Den innebygde nettdelen er derfor ikke frakopleet nettet så lenge apparatet er tilsluttet nettkontakten.

For å redusere faren for brann eller elektrisk støt, skal apparatet ikke utsettes for regn eller fuktighet.

English .....	4	<b>English</b>
Français.....	24	<b>Français</b>
Español .....	44	<b>Español</b>
Deutsch.....	64	<b>Deutsch</b>
Nederlands .....	84	<b>Nederlands</b>
Italiano.....	104	<b>Italiano</b>

<b>General information</b>	
Scope of supply.....	4
Maintenance .....	4
Setup .....	4
Environmental information.....	4
Trademark acknowledgment.....	4
<b>Controls</b> .....	5
<b>Remote control</b>	
Remote control usage.....	6
Remote control buttons .....	7
Programming the universal remote control.....	8
<b>Connectors</b> .....	9
<b>Connections</b>	
Audio connections.....	10
Digital audio connections .....	10
System control bus, CINEMA LINK .....	11
Video connections.....	11
Mains .....	12
Speaker connections.....	12
TV as the center speaker .....	12
Antenna connections .....	12
<b>System setup</b>	
Positioning of the speakers .....	13
Speaker setup and testing.....	13
Power handling .....	13
Headphones .....	13
<b>Display</b> .....	14
<b>Menus</b>	
Receiver menu.....	15
TV menu .....	16
<b>Source selection</b>	
SOURCE SELECTOR.....	17
Reassigning a source selection .....	17
Using one source selection for two or more appliances .....	17
<b>Playback, recording</b>	
Playing a source.....	18
Adjusting the sound.....	18
Recording from a source.....	18
Recording from the digital output .....	18
<b>Surround sound</b>	
About surround sound.....	19
Switching surround sound .....	19
Surround sound settings.....	19
<b>Tuner</b>	
Tuning to radio stations .....	20
Switching FM sensitivity .....	20
Storing radio stations .....	20
Tuning to stored radio stations.....	21
Resorting stored radio stations .....	21
Naming radio stations .....	21
Clearing station names .....	21
RDS  .....	22
RDS News and Traffic Announcement.....	22
<b>Technical data</b>	
Receiver.....	22
<b>Troubleshooting</b>	
Warning.....	23
Troubleshooting.....	23

## Scope of supply

This receiver is supplied including:

- an universal remote control
- 2 batteries for the remote control, size AA
- a system bus cable for the CINEMA LINK connection
- a loop antenna
- a wire antenna
- this instruction booklet

## Maintenance

Clean the receiver with a soft, slightly dampened, lint-free cloth. Do not use any cleaning agents as they may have a corrosive effect.



Do not expose the receiver to humidity, rain, sand or excessive heat (caused by heating equipment or direct sunlight).

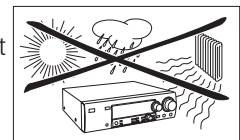

## Setup

If you have stacked the components of your system, the receiver must be on top. Place the receiver on a flat, hard, stable surface. Do not cover any vents and leave 50 cm above and 10 cm left and right of the receiver free for ventilation.

For good reception the loop antenna should not be placed on top of or beneath VCRs, CD recorders, DVD players, TVs and other radiation sources.

## Environmental information

All redundant packing material has been omitted. We have done our utmost to make the packaging easily separable into three mono materials: cardboard (box), polystyrene foam (buffer) and polyethylene (bags, protective foam sheet).

Your set consists of materials which can be recycled if disassembled by a specialized company. Please observe the local regulations regarding the disposal of packing materials, exhausted batteries and old equipment.

## Trademark acknowledgment

Manufactured under license from Dolby Laboratories. "DOLBY", "DOLBY DIGITAL", "PRO LOGIC" and the double-D symbol  are trademarks of Dolby Laboratories. Confidential unpublished works. © 1992–1997 Dolby Laboratories. All rights reserved.

***This set complies with the radio interference requirements of the European Community.***

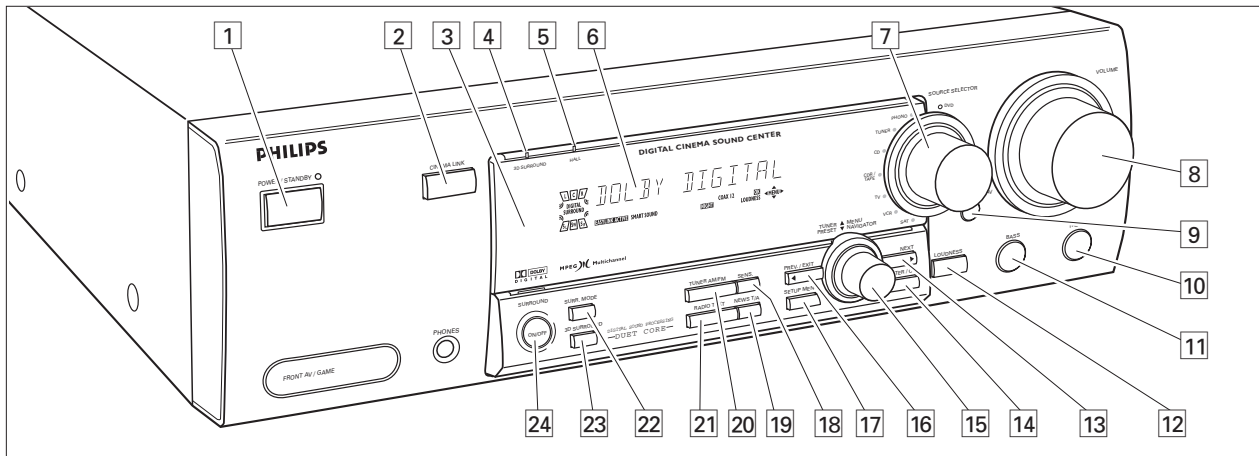

- 1 **POWER / STANDBY** .....Switches the receiver on and off.
- 2 **CINEMA LINK** .....Switches the system control bus between the receiver and the TV on and off.
- 3 .....Sensor for the infrared remote control.
- 4 **3D SURROUND** .....Control light for virtual 3D surround.
- 5 **HALL** .....Control light for HALL.
- 6 .....Display
- 7 **SOURCE SELECTOR** .....Selects the different audio and video connectors.
- 8 **VOLUME** .....Increases and decreases the volume level.
- 9 **FRONT AV** .....Selects the FRONT AV / GAME input (FR 970 only).
- 10 **TREBLE** .....Adjusts the treble when used in combination with VOLUME.
- 11 **BASS** .....Adjusts the bass when used in combination with VOLUME.
- 12 **LOUDNESS** .....Switches LOUDNESS on and off.
- 13 **NEXT ►** .....TUNER: searches radio stations. MENU: switches to the next menu level.
- 14 **ENTER / OK** .....Confirms selected menu values.
- 15 **TUNER PRESET ◄ MENU NAVIGATOR**  
TUNER: switches to the next and previous stored radio station.  
MENU: moves upwards and downwards.
- 16 **◄ PREV. / EXIT** .....TUNER: searches radio stations. MENU: switches to the previous menu level.
- 17 **SETUP MENU** .....Switches the menu on and off.
- 18 **SENS.** .....Switches between low and high tuner sensitivity.
- 19 **NEWS/TA** .....Switches the RDS news and RDS traffic announcement on and off.
- 20 **TUNER AM/FM** .....Switches the wavebands of the tuner.
- 21 **RADIO TEXT** .....Scrolls through the different RDS information.
- 22 **SURR. MODE** .....Switches through the different surround effects.
- 23 **3D SURROUND** .....Switches virtual 3D surround on and off.
- 24 **SURROUND ON/OFF** .....Switches the surround sound on and off.

# REMOTE CONTROL

## Remote control usage

Open the battery compartment of the remote control and insert 2 alkaline batteries, type **AA** (R06, UM-3).

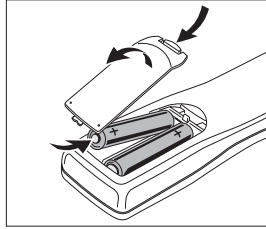

Remove batteries if they are flat or the remote control is not going to be used for a long time.

**Batteries contain chemical substances, so they should be disposed of properly.**

The buttons on the remote control work the same way as the corresponding ones on the receiver.







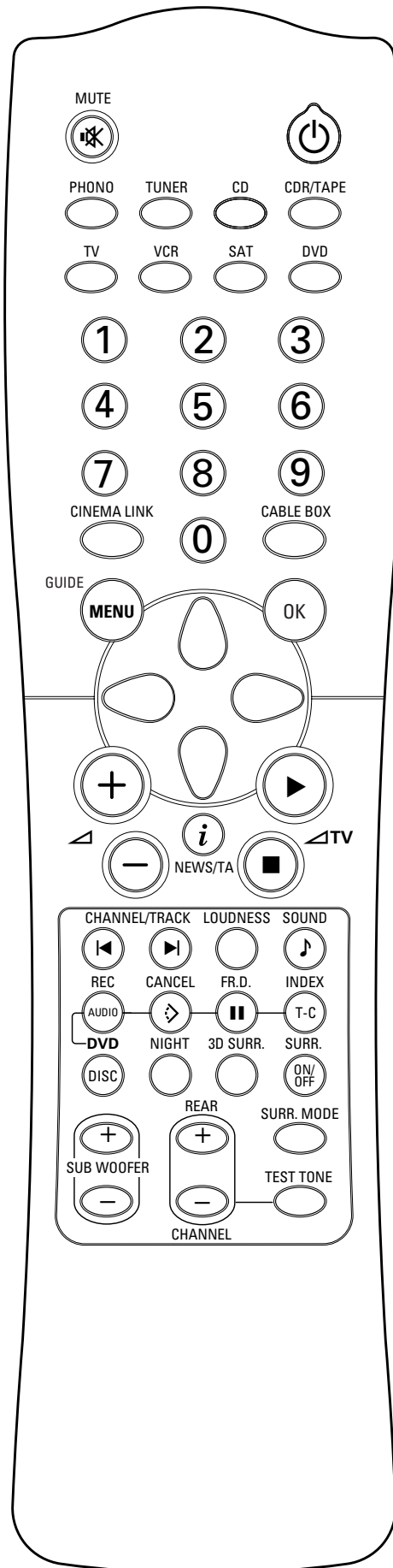





### Important!

You have to press a source button for longer than 2 seconds to switch the sound source on the receiver. Pressing a source button for less than 2 seconds will only switch the remote control to use the commands for the selected product.

The remote control remains tuned to the selected source until another source button on the remote control is pressed. This enables you to operate additional sources (i. e. winding a tape) without changing the source on the receiver.



## Remote control buttons

-  MUTE .....Mutes the sound of the receiver.
-  .....Switches the receiver to standby.
- PHONO, TUNER, CD,  
CDR/TAPE, TV,  
VCR, SAT, DVD.....Switches the remote control to the  
commands of the different products.  
Selects the sources if pressed longer  
than 2 seconds. SAT only works with  
*digital* satellite receivers.
- 1-0.....Keys in numbers for tracks, stations or  
frequencies. Numbers consisting of  
two figures must be keyed in within  
2 seconds.
- CINEMA LINK.....Switches the system connection  
between the receiver and the TV on  
and off.
- CABLE BOX.....Without function.
- MENU GUIDE** .....**TUNER:** Switches the receiver menu  
on and off.  
**DVD, TV:** Switches the DVD/TV menu  
on and off.
- OK.....Confirms menu options.
- Arrow buttons .....**TUNER:** Moves in the menus.  
Right/left arrows are tuning up/down.  
**CD, CDR:** Left/right arrows are  
searching backwards/forwards,  
up/down arrows are selecting the  
next/previous track.
- +  .....Increases the receiver volume.
-  .....Decreases the receiver volume.
-  NEWS/TA.....Switches the functions NEWS and  
TRAFFIC ANNOUNCEMENT on and off.  
**TV:** Switches teletext on and off.  
**SAT:** Switches the information text on  
and off.
-  **TV** .....Increases the TV volume.  
**CD, CDR, VCR, DVD:** Starts playback.
-  **TV** .....Decreases the TV volume.  
**CD, CDR, VCR, DVD:** Stops playback.
-  CHANNEL/TRACK ...Selects the previous preset tuner  
station.  
**VCR:** Rewinds the tape.  
**CD, CDR, DVD:** Selects the previous  
track.  
**TV:** Selects the previous channel.
-  CHANNEL/TRACK ...Selects the next preset tuner station.  
**VCR:** Fast forwards the tape.  
**CD, CDR, DVD:** Selects the next track.  
**TV:** Selects the next channel.
- LOUDNESS .....Switches LOUDNESS on and off.
-  SOUND .....Scrolls through the different smart  
sounds.
- REC, DVD AUDIO.....**CDR, VCR:** Starts recording.  
**DVD:** Switches audio tracks.
- CANCEL, DVD  .....**CD, CDR, SAT, VCR:** Clears a  
program, cancels selections.  
**DVD:** Switches the view angle.
- FR.D., DVD  .....**TUNER:** Switches to FREQUENCY  
DIRECT.  
**CD, CDR, VCR, DVD:** Pauses playback.
- INDEX, DVD T-C.....**VCR:** Switches the index search on  
and off.  
**SAT:** Switches the themes on and off.  
**DVD:** Switches between title and  
chapter.
- DISC.....**CD-, CDR-, DVD-Changers:**  
Switches to the next disc.
- NIGHT .....Switches NIGHT MODE on and off.
- 3D SURR.....Switches virtual 3D surround on and off.
- SURR. ON/OFF.....Switches SURROUND SOUND on and off.
- + / - SUBWOOFER...Increases/decreases the subwoofer  
volume.
- + / - REAR .....Increases/decreases the volume of the  
rear speakers. While test tone is on,  
the volume of the speakers you are  
hearing can be increased/decreased  
with these buttons.
- SURR. MODE.....Scrolls through the different surround  
modes.
- TEST TONE .....Switches the test tone on and off.  
While test tone is on, the volume of  
the speakers you are hearing can be  
increased/decreased with  
+ / - REAR.

## Programming the universal remote control

You can identify the universal remote control by the inscription **Multibrand/Universal**.

The universal remote control must be programmed to use the codes for your appliances of different brands. This is done by keying in a 4-digit code or by scanning the codes until the correct one is found. We recommend to using the 4-digit code. This method is faster and more reliable. The code scanning method should only be used if you cannot find the code for one of your appliances. The code table can be found at the end of the booklet.

### **Important!**

*The buttons of the remote control must be used for programming, not the buttons of the receiver or other appliances.*



### **Programming with the 4-digit code**

- 1 Keep the source button for the appliance which should be controlled and  pressed for 3 seconds.
- 2 Key in the 4-digit code for the appliance (codetable at the end of the booklet).

*Notes:*

- If more than 4 digits are entered, the remote control will recognize only the ones keyed in first.
- If you do not key in a code within 30 seconds the remote control will switch off the programming function without changing the code.
- To program a new appliance, simply overwrite the old code by entering a new one.

### **Scanning the codetable**

- 1 Switch on the appliance which should be controlled.
  - 2 Keep the source button for the appliance which should be controlled and  pressed for 3 seconds.
  - 3 Press and release  again.
    - The remote control sends the codes for channel up or standby (depending on the selected source) for one brand after the other.
  - 4 As soon as the appliance reacts – switches to the next channel or to standby – press  to confirm the code.
    - The identified code will be used.
- If the set does not react within 2 minutes, the code for this appliance is not stored in the remote control. The code of the remote control will remain unchanged.

*Note: When taking out the batteries of the remote control for more than 1 minute the codes must be reprogrammed.*

Once you have found and tested the codes for your various appliances, you may want to write them down here.

PHONO .....

TUNER .....

CD .....

CDR/TAPE .....

TV .....

VCR .....

SAT .....

DVD .....

### **Resetting the remote control**

- 1 Keep one of the source buttons and  pressed for 3 seconds.
- 2 Key in the 3-digit code 981.
  - The remote control is now reset to all its original Philips codes.



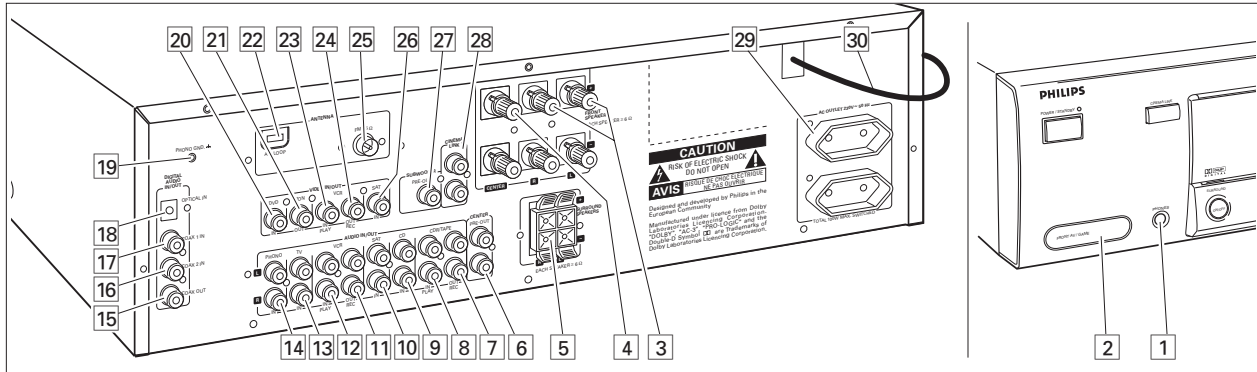

Connectors	Connectors name	Connect to:
6.3 mm headphone socket at the front	<b>1 PHONES</b>	A headphone with a 6.3 mm plug.
Audio and video inputs at the front (FR 970 only)	<b>2 FRONT AV / GAME</b>	Audio and video out sockets of appliances such as video cameras and game consoles.
FRONT SPEAKERS	<b>3 R, L</b>	Right and left front speaker.
	<b>4 CENTER</b>	Center speaker.
SURROUND SPEAKERS	<b>5 R, L</b>	Right and left surround speaker.
AUDIO IN/OUT	<b>7 CDR/TAPE OUT</b>	Input of a CD recorder or a tape deck.
	<b>8 CDR/TAPE IN</b>	Output of a CD recorder or a tape deck.
	<b>9 CD IN</b>	Output of a CD player.
	<b>10 SAT IN</b>	Output of a satellite system.
	<b>11 VCR OUT</b>	Input of a video recorder.
	<b>12 VCR IN</b>	Output of a video recorder.
	<b>13 TV IN</b>	Output of a TV.
	<b>14 PHONO IN</b>	Output of a turntable with MM coil.
	<b>19 PHONO GND</b> 	Ground cable of a turntable.
DIGITAL AUDIO IN/OUT	<b>15 COAX OUT</b>	Coaxial input of digital appliances such as CD recorders or MD recorders.
	<b>16 COAX 2 IN</b>	Coaxial output of digital appliances.
	<b>17 COAX 1 IN</b>	Coaxial output of digital appliances.
	<b>18 OPTICAL IN</b>	Optical output of digital appliances such as DVD players, CD players, CD recorders or MD players.
VIDEO IN/OUT	<b>20 DVD IN</b>	Output of a DVD player.
	<b>21 MON OUT</b>	Input of a monitor (e. g. the TV).
	<b>23 VCR IN</b>	Output of a video recorder.
	<b>24 VCR OUT</b>	Input of a video recorder (for recording).
	<b>26 SAT IN</b>	Output of a satellite system.
Antenna connectors	<b>22 AM LOOP</b>	Frame antenna supplied.
	<b>25 FM 75 Ω</b>	Wire antenna supplied or exterior antenna.
Preamplified outputs	<b>6 CENTER PRE-OUT</b>	Input of a TV when it is used as the centre speaker (only possible when the CINEMA LINK system bus is connected).
	<b>27 SUBWOOFER PRE-OUT</b>	Input of a powered subwoofer.
System control bus	<b>28 CINEMA LINK</b>	System control bus sockets of a Philips TV with CINEMA LINK.
Mains outlets (not on all versions)	<b>29 AC OUTLET</b>	Supplies same voltage as mains. Up to 100 W total permitted load.
Mains lead	<b>30</b>	<b>After all other connections have been made</b> , connect the mains lead to the wall socket.

# CONNECTIONS

## Audio connections

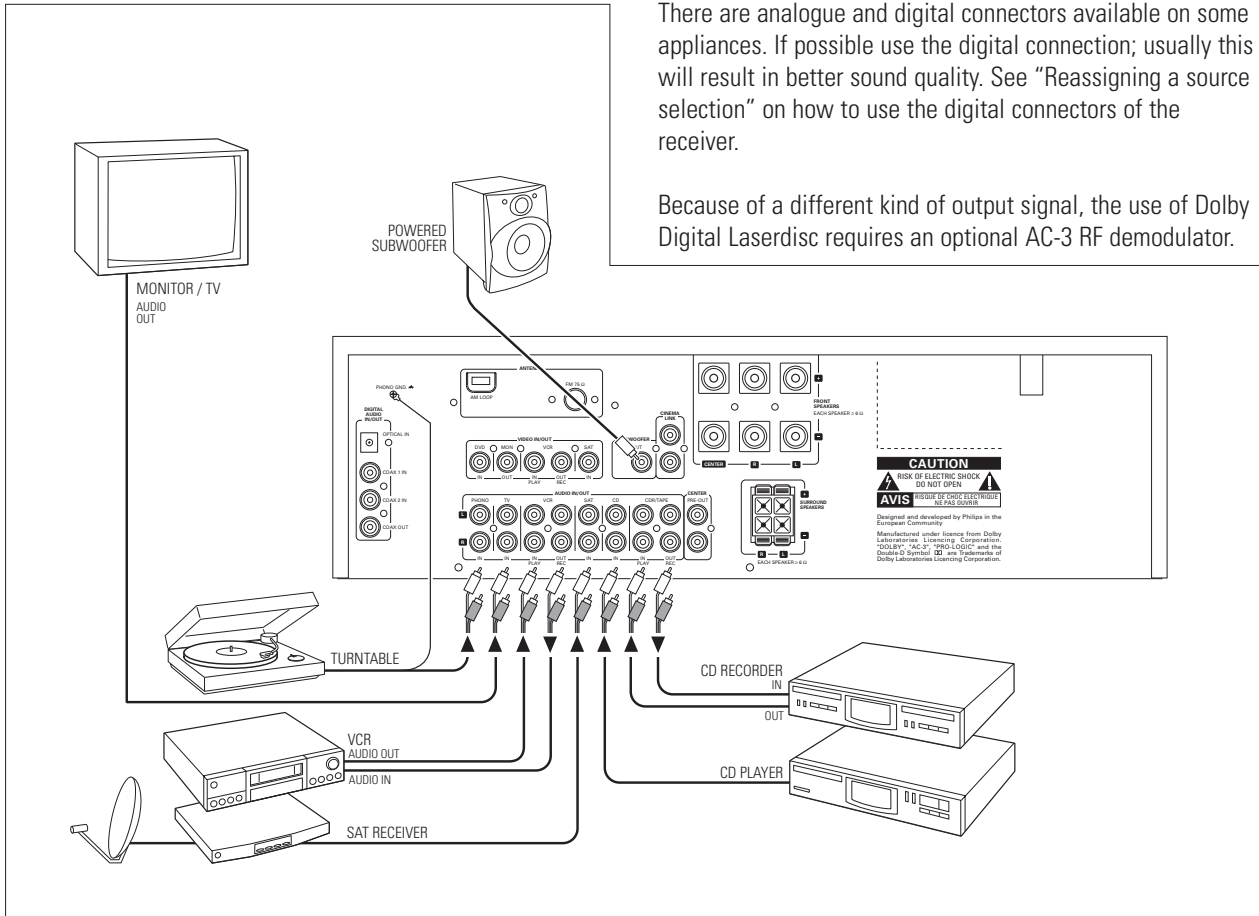

## Digital audio connections

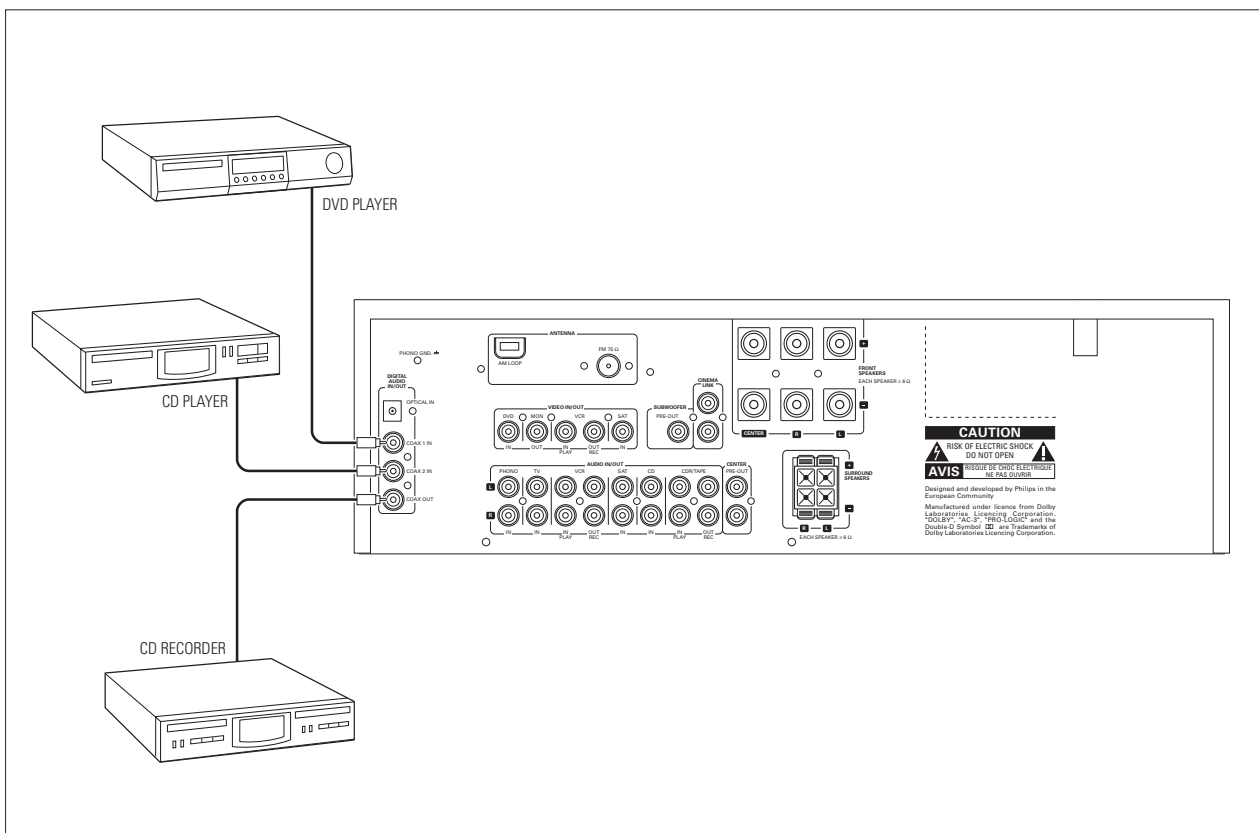

## System control bus, CINEMA LINK

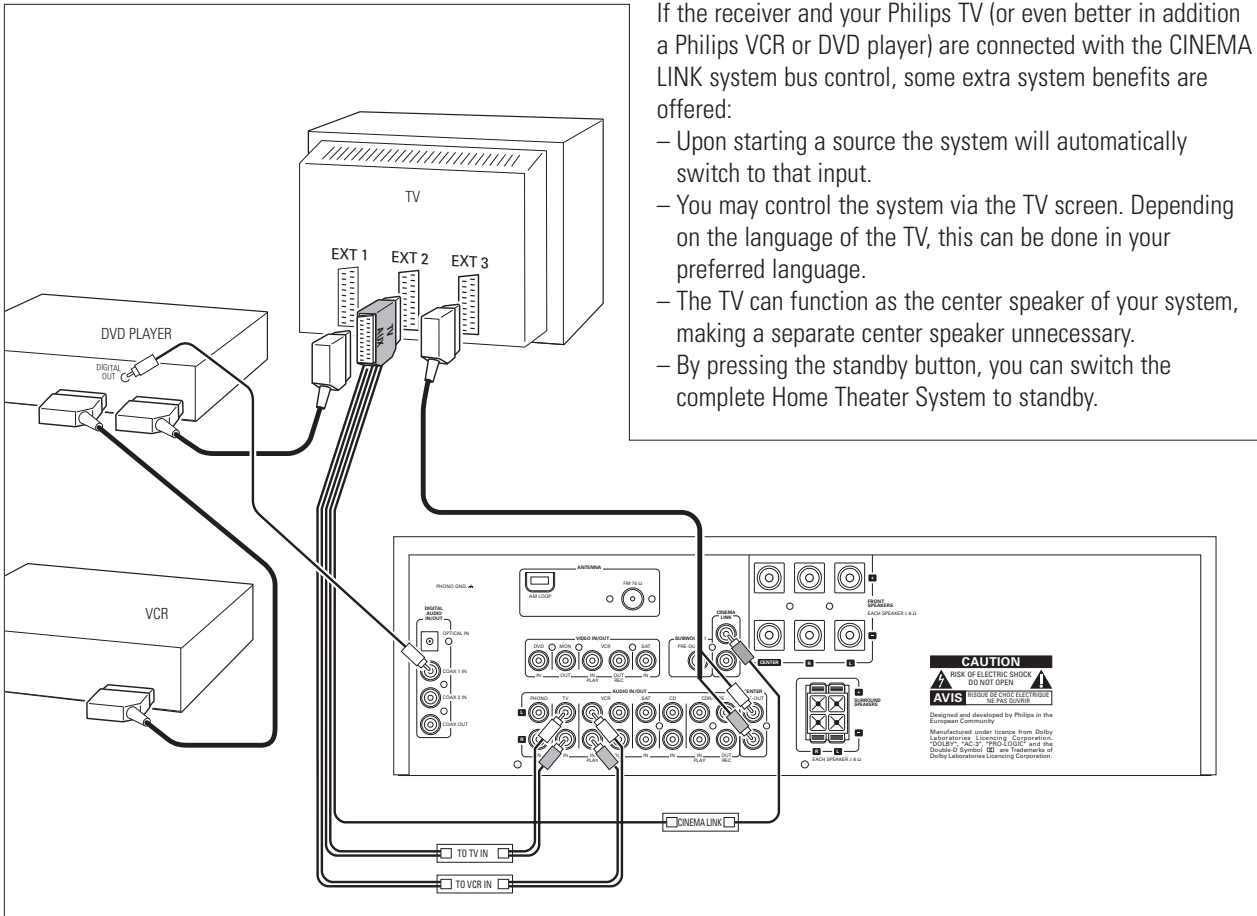

## Video connections

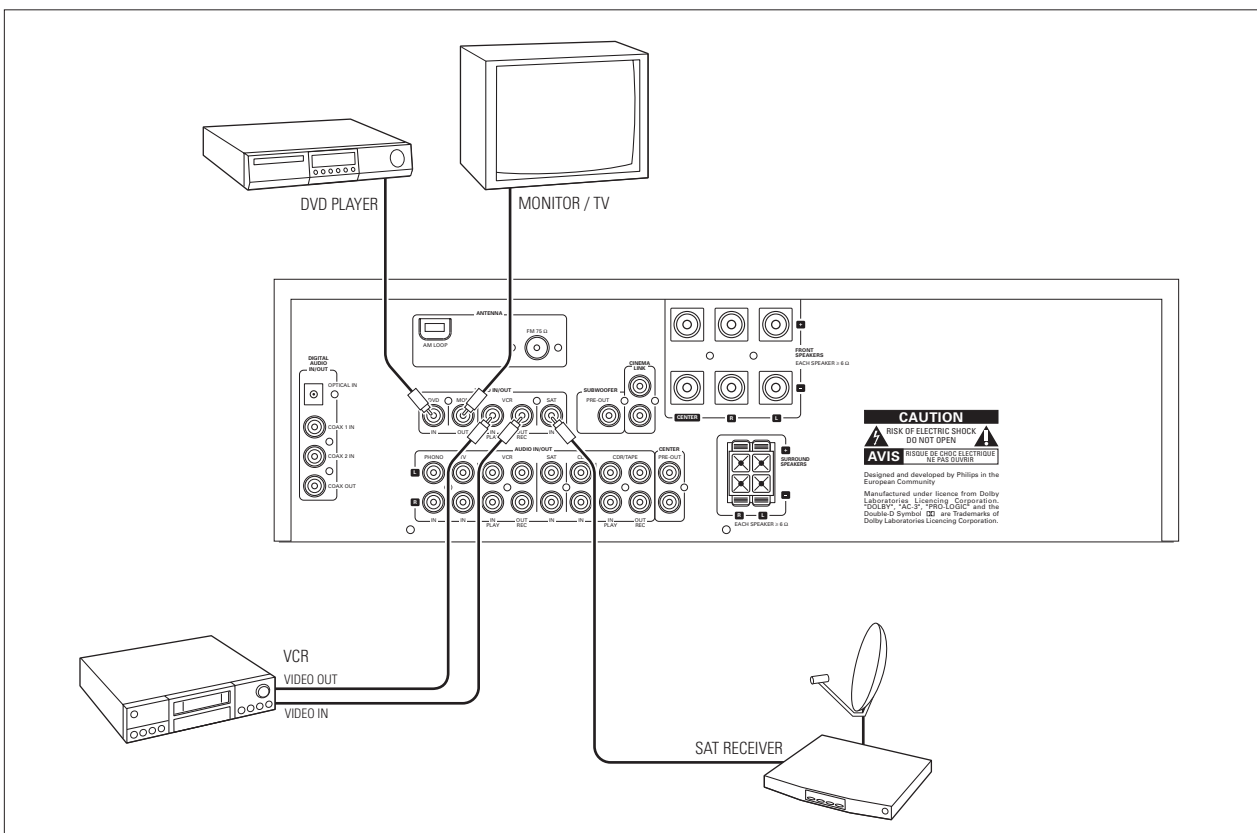

# CONNECTIONS

## Mains

*The type plate is located on the rear of the receiver.*

- 1 Check whether the mains voltage as shown on the type plate corresponds to your local mains voltage. If it does not, consult your dealer or service organization.
- 2 Connect the mains cable to the wall socket.

To disconnect the set from the mains completely, remove the mains plug from the wall socket.

**For users in the U. K.: please follow the instructions on page 2.**

## Speaker connections

Some of the speaker connections on the receiver are screw connectors and some are click-fit connectors. Use them as shown below.

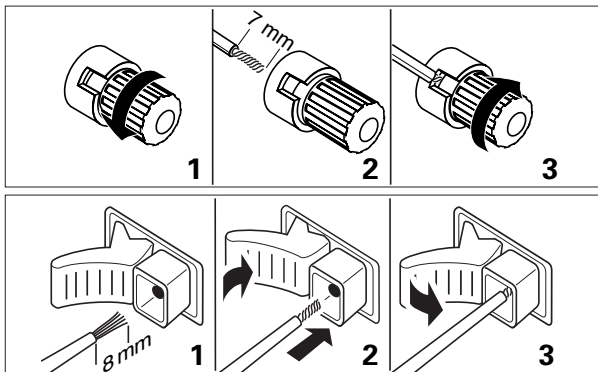

- 1 Always connect the coloured (or marked) wire to the coloured terminal and the black (or unmarked) wire to the black terminal.
- 2 Connect:
  - Left front speaker to L (red and black)
  - Right front speaker to R (red and black)
  - Center speaker to CENTER (blue and black)
  - Left surround speaker to SURROUND L (grey and black)
  - Right surround speaker to SURROUND R (grey and black)

## TV as the center speaker

You may use your Philips TV with CINEMA LINK as the center speaker. For TVs with a scart connector an additional audio cinch-to-scart cable is needed. For TV's with cinch connectors additional cinch cables are needed. These cables must be connected to the blue CENTER PRE-OUT connector on the back. Look into the instruction manual of your TV on how to use it as the center speaker.

## Antenna connections

### AM (MW) antenna

The loop antenna supplied is for indoor use only. Position the antenna as far away as possible from the receiver, the TV, the cables, a DVD player, a VCR and other radiation sources.

- 1 Fit the plug of the frame antenna to AM LOOP as shown below.
- 2 Turn the antenna for optimum reception.

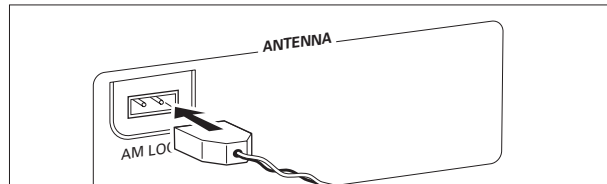

### FM antenna

The wire antenna supplied can only be used to receive nearby stations. For better reception we recommend using a cable antenna system or an outdoor antenna.

- 1 Fit the supplied wire antenna to FM 75  $\Omega$  as shown below.
  - 2 Move the antenna in different positions for optimum reception.
- If you are using a cable antenna system or an outdoor antenna, fit the antenna plug to FM 75  $\Omega$  instead of the wire antenna.

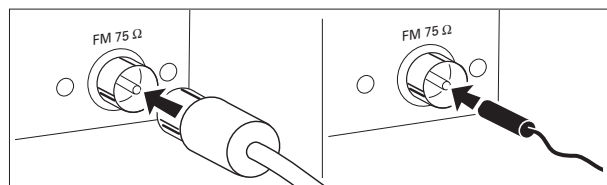

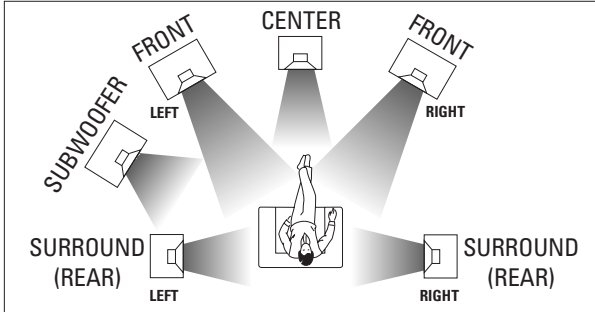

## Positioning of the speakers

### General hints for positioning

Avoid positioning the speakers in a corner or on the floor as this will boost the bass tones too much. Placing the speakers behind curtains, furniture, etc. will reduce the treble response. The listener should always be able to "see" the speakers.

Each room has different acoustic characteristics and the positioning possibilities are often limited. You can find the best position for your speakers by referring to the picture above.

As a minimum we recommend 5 speakers (2 front, a center, 2 surround) for good surround sound. It is possible to reproduce some kind of surround sound with fewer speakers. This is done by redirecting the signals which are foreseen for the missing speakers to the existing ones. See "Menus" on how to set up the receiver correctly for the number and size of the speakers used.

### Positioning the front speakers

The front speakers should be placed right and left in front of the listening position like usual stereo speakers.

### Positioning the center speaker

The center speaker should be placed in the center between the two front speakers, e. g. underneath or on top of the TV. The best height for the center speaker is the height of the listener's ears (while seated).

### Positioning the surround speakers

The surround speakers should face each other and be in line with, or slightly behind the listener.

### Positioning the subwoofer

A subwoofer can be used to enhance the bass performance of your system dramatically. The subwoofer can be positioned anywhere in the room, because it is not possible to locate the source of deep tones. Nevertheless, you should not place the subwoofer in the middle of a room, since the bass could be severely weakened. Do not place any object on the subwoofer.

## Speaker setup and testing

The relative volume of the speakers must be adjusted for optimal surround sound. You should be at your usual listening position when adjusting the speaker volume. See "Receiver menus" on how to set up the receiver for the used speakers.

- 1 Press POWER / STANDBY to switch on the receiver.
- 2 Press TEST TONE on the remote control.
  - A test tone coming from the different speakers, except the subwoofer, is heard.
- 3 Press + / - REAR on the remote control to increase/decrease the volume of the actual speaker. The best result is achieved when all speakers have equal volume in the listening position.
- 4 Press TEST TONE on the remote control.
  - The test tone stops.

*Note: If you are not completely satisfied with the volume settings, we recommend making minor adjustments to them during surround sound playback.*

## Power handling

If the receiver is used at very high power it can produce distortions which may seriously damage your speakers. If distortions occur, reduce the volume and the tone controls to a level where the sound is acceptable again.

**To avoid overheating of the set a safety circuit has been built in. Therefore your set may disconnect under extreme conditions. If this happens, switch the set off and let it cool down before reusing it.**

## Headphones

Connecting headphones to PHONES will switch off the speakers. The receiver switches to STEREO and surround sound will be reduced to a stereo signal which is reproducible by standard headphones.

Disconnecting the headphones switches on the speakers again. If you wish to enjoy surround sound again, switch the receiver back to surround sound.

# DISPLAY

## Display

The display of the receiver is divided into 4 sections, which are to be used for the following:

### Speaker diagram



A rectangle with a letter in it shows that a speaker has been selected in the setup menu. However, the subwoofer indicator will only light when a subwoofer signal is available. If only a letter is shown, this speaker is not used and its sound is reproduced by the other speakers.

- .....virtual 3D surround
- SURROUND**.....surround sound is reproduced
- DIGITAL SURROUND** ....digital surround sound is reproduced
- L, R** .....front left and right speaker
- C**.....center speaker
- SL, SR** .....surround speakers
- SW**.....subwoofer

### Menu indication



These signs show you if the menu is on or off and indicate in which direction you may move.

- MENU** .....menu is on
- .....You may move backwards to the previous menu topic using ◀ PREV. / EXIT ("left" key on the remote control).
- .....You may move up in an option list using MENU NAVIGATOR ("up" key on the remote control).
- .....You may move down in an option list using MENU NAVIGATOR ("down" key on the remote control).
- .....You may move forward to the next menu topic using NEXT ▶ ("right" key on the remote control).
- .....You may confirm the displayed value.

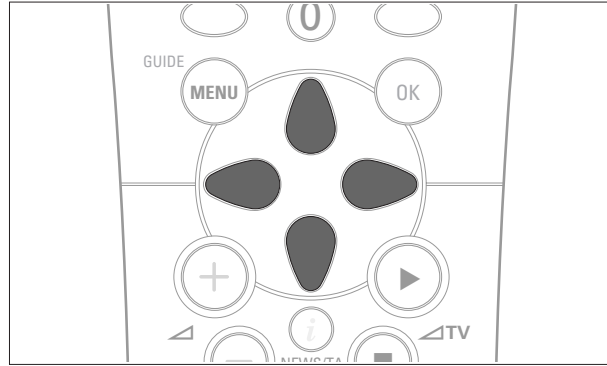

## Receiver menu

The receiver is equipped with a menu system. The menu is used for the setup of the receiver. The different menu options are related to each other in a logical way. Let's assume you have no center speaker connected, and therefore switched *CENTER SPEAKER* to *NO*. If you try to use *VOL CENTER*, a message will be scrolled that this is not possible (*INSTALL CENTER SPEAKER*).

The menu always works the same way. Arrows in the display show you the possible moving directions.

- 1 Press **SETUP MENU**.  
→ **MENU**, and \* *EFFECTS* is displayed.
- **You can exit the menu at any time by pressing SETUP MENU.**
- 2 Turn **▲** *MENU NAVIGATOR* until the desired option (or a value) is displayed.
- 3 Press **NEXT ▶** to choose the displayed option (or **ENTER / OK** to confirm a value).
- You can leave any option (values remain unchanged) by pressing **◀ PREV. / EXIT**.

### Menu structure

- \* *EFFECTS*
  - Switches sound effects.
  - *3D SURR*  
virtual 3D surround: 0...100 %
- \* *VOL BALANCE*
  - Adjusts the relative volume balance between the connected speakers.
  - *TEST TONE*  
Test tone: on/off
  - *VOL FRONT-L*  
Volume front left speaker: -50...+50
  - *VOL FRONT-R*  
Volume front right speaker: -50...+50
  - *VOL CENTER*  
Volume center speaker: -50...+50
  - *VOL REAR-L*  
Volume rear left speaker: -50...+50
  - *VOL REAR-R*  
Volume rear right speaker: -50...+50
  - *VOL SUBWOOFER*  
Volume subwoofer: -50...+50
- \* *SPEAKR SETUP*
  - Selects the used speakers.
  - *SUBW PRESENT*  
Subwoofer present: yes/no
  - *CENTER SPEAKR*  
Center speaker present: yes/no
  - *REAR SPEAKR*  
Rear speakers present: yes/no

- \* *SPEAKR SIZES*
  - Chooses the speaker sizes of the used speakers, for optimal sound reproduction. *LARGE* indicates a speaker which can reproduce frequencies lower than 50 Hz. If *SUBW PRESENT* is set to *NO*, *FRONT SIZE* can only be set to *LARGE*. If *FRONT SIZE* is set to *SMALL*, *CENTER SIZE* can only be set to *SMALL* and consequently a subwoofer must be connected.
  - *SUBW PRESENT*  
Subwoofer present: yes/no
  - *FRONT SIZE*  
Left and right front speakers: small/large
  - *CENTER SIZE*  
Center speaker: small/large
  - *REAR SIZE*  
Rear speakers: small/large
- \* *SPK DISTANCE*
  - Distance between the usual listening position and the speakers. This defines the delay time for the surround sound.
  - *DISTANCE L/R*  
Distance to front speakers: 1...10 m
  - *DISTANCE CNTR*  
Distance to center speaker: 1...10 m
  - *DISTANCE REAR*  
Distance to rear speakers: 1...10 m
- \* *SELECT INPUT*
  - Assigns the audio input connectors to the different source selections chosen with *SOURCE SELECTOR* (see "SOURCE SELECTION" for details).
  - *COAX 1*  
Digital coaxial input 1, COAX 1 IN
  - *COAX 2*  
Digital coaxial input 2, COAX 2 IN
  - *OPT*  
Digital optical input, OPTICAL IN
  - *SAT IN*  
Analogue audio input SAT IN
  - *VCR IN*  
Analogue audio input VCR IN
  - *TV IN*  
Analogue audio input TV IN
  - *CDR IN*  
Analogue audio input CDR IN
  - *CD IN*  
Analogue audio input CD IN
- \* *TUNER*
  - Setup for preset radio stations (see "TUNER" for details).
  - *AUTO INSTALL*  
Stores radio stations automatically
  - *MAN INSTALL*  
Stores radio stations manually
  - *GIVE NAME*  
Allows to assign names to stored radio stations
  - *RESHUFFLE*  
Resorts stored radio stations

## TV menu

If the receiver is connected to a Philips CINEMA LINK TV via the CINEMA LINK system control bus sockets (see "CONNECTIONS"), you may use the TV to set up the system. An option called RECEIVER will be added to the TV menu.

If CINEMA LINK is on, adjustments on the receiver will be shown on the TV screen for a few seconds. Consult the instruction booklet of your TV on how to use the TV menu. The options offered may vary by TV model.

### Switching the connection

- Press CINEMA LINK to switch the connection between the receiver and the TV either on or off.
  - If the connection is switched on, **CINEMA LINK ON** is displayed.

*Note: We recommend switching CINEMA LINK off during recording. This avoids unwanted interruptions due to switching TV functions.*

If CINEMA LINK is switched on and the TV menu is active, **TV MENU** is displayed and the menu and sound functions on the receiver are locked.



## SOURCE SELECTOR

When selecting a source by turning SOURCE SELECTOR, the audio and video inputs with the corresponding name are activated. The incoming signal is reproduced by all audio and – if the source includes a video signal – video outputs of the receiver. It is possible to reassign a source selection to other than these standard inputs.

### Source selected .....Connectors used

DVD.....	COAX 1 digital audio input and DVD IN video input
PHONO.....	PHONO IN audio input
TUNER.....	The tuner part of the receiver is used, all inputs are switched off.
CD.....	CD IN audio input
CDR/TAPE.....	CDR/TAPE IN audio input
TV.....	TV IN audio input and no video input
VCR.....	VCR IN audio input and VCR IN video input
SAT.....	SAT IN audio input and SAT IN video input

## Reassigning a source selection

If a source is selected with SOURCE SELECTOR the standard audio input is used. To change this, the source selection must be reassigned to another audio input.

Example: Reassigning **CD** from the analogue CD IN audio input to the digital COAX 2 IN audio input.

- 1 Choose \* **SELECT INPUT** from the menu and press **NEXT ▶**.
- 2 Turn SOURCE SELECTOR to select the source which should be reassigned (e. g. **CD**).  
→ The name of the source is displayed and the light of the source flashes.
- 3 Turn **◆** MENU NAVIGATOR to select the input connectors which should be used (e. g. **CD** → **COAX 2**).
- 4 Press **ENTER / OK** to confirm your selection.  
→ **STORE** is displayed briefly.
- 5 This source selection is now using the chosen audio input (e. g. **CD** uses the COAX 2 IN input connectors, **COAX 2** lights when switching to CD).

## Using one source selection for two or more appliances

You may assign more than one source to a source selection. This can be useful when products are connected one after the other in a chain.

Example: A VCR is connected to the TV but only the TV is connected to the receiver. Both SOURCE SELECTOR settings, TV as well as VCR, have to use the TV input connectors.

- 1 Choose \* **SELECT INPUT** from the menu and press **NEXT ▶**.
- 2 Turn SOURCE SELECTOR to select the source which should be reassigned (e. g. **VCR**).  
→ The name of the source is displayed and the light of the source flashes.
- 3 Turn **◆** MENU NAVIGATOR to select the input connectors which should be used (e. g. **VCR** → **TV IN**).
- 4 Press **ENTER / OK** to confirm your selection.  
→ **STORE** is displayed briefly.
- 5 This source selection is now using the chosen audio input (e. g. **VCR** uses the TV IN input connectors, **VCR (TV IN)** is displayed briefly when switching to VCR).

## Playing a source

- 1 Press POWER / STANDBY to switch on the receiver.
- 2 Turn SOURCE SELECTOR to select a source.  
→ The name of the source is displayed.
- You can select the FRONT AV / GAME input by pressing FRONT AV (FR 970 only).
- 3 Start playback of the source as usual.

## Adjusting the sound

- Turn VOLUME to adjust the volume.  
→ VOLUME and the volume level between 0 and 50 is displayed.
- 1 Press BASS or TREBLE.  
→ BASS or TREBLE and the actual value are displayed briefly. Then TURN VOLUME KNOB TO CHANGE is scrolled.
  - 2 Turn VOLUME to adjust the bass or treble.  
→ BASS or TREBLE and the actual value are displayed.

*Note : If VOLUME is not turned within 5 seconds or if any other control is used, the bass or treble adjustment is switched off.*

- Press **SOUND** on the remote control to scroll through the built-in smart sounds: MOVIE, SPEECH, MUSIC, MULTIMEDIA and PERSONAL. (PERSONAL is the userdefined bass and treble setting.)  
→ **SMART SOUND** is displayed and the name of the chosen sound profile is scrolled once if smart sound is on.
- Press **LOUDNESS** to switch loudness either on or off.  
→ **LOUDNESS** is displayed if loudness is on.

## Recording from a source

If you wish to record from a source you must select it with SOURCE SELECTOR. The incoming signal is reproduced by all audio and – if the source includes a video signal – video outputs of the receiver. The sound settings do not affect the recording.

- 1 Turn SOURCE SELECTOR (or press FRONT AV – FR 970 only) to select the source you want to record from.  
→ The name of the source is displayed.
- 2 Prepare the desired recording appliance. It must be connected to one of the outputs of the receiver.
- 3 Start recording on the recording appliance.
- 4 Start the playback of the source as usual.

*Notes: – The audio and video signal of VCR IN is not reproduced by VCR OUT. The same applies to the audio signal of CDR/TAPE IN to CDR/TAPE OUT.  
– We recommend not to use the digital output COAX OUT of the receiver to record from an analogue source. Use the analogue output CDR/TAPE instead.*



## Recording from the digital output

It is possible to connect a digital recorder to the digital output of the receiver. In this way, all signals coming from the digital inputs can be recorded directly on the connected audio recorder. The receiver will also convert all signals coming from the analogue inputs to the digital output.

The receiver can be used to record digitally a multichannel surround sound audio signal (Dolby Digital or MPEG) from, for example, DVD to CD-R. The receiver will convert the digital multichannel signal into a stereo signal without loss of relevant sound information.

*Notes: – Do not use the 3D SURROUND feature while making digital recordings as this will distort the digital audio signal.  
– When recording a Dolby Digital or MPEG signal, each track must be recorded individually.*

## About surround sound

Surround sound gives you a complete new listening sensation. You will have the feeling of being in the middle of the action, because sound is coming from everywhere around you. Look out for TV broadcasts, audio and video tapes and discs with the   or  **Multichannel** marks which are encoded for multichannel surround sound. You should prefer Dolby Digital or MPEG Multichannel to get the best out of your receiver.

Notice that DVDs do not always carry full multichannel surround. To be sure that a disc is multichannel encoded consult your dealer.

Most ordinary stereo tapes and discs can be replayed using surround sound settings with good results. If the reproduction is distorted in surround mode, switch to normal stereo mode.

The availability of the various surround sound modes described depends on the number of speakers used and the incoming sound information.

## Switching surround sound

With surround sound on, you can switch through the different surround modes. Note that the possibilities are related to speaker setup defined in the receivers menu.

If a digital surround signal is detected, the receiver will scroll either *DOLBY DIGITAL* or *MPEG*.

- 1 Press **SURROUND ON/OFF** to switch on the surround sound.
  - The surround mode in use is scrolled.
- 2 Press **SURR. MODE** repeatedly to listen to the different surround modes (if available).
  - The chosen mode and the speakers used are displayed. If the incoming multichannel signals are reduced to fewer output signals, **DOWNMIX** is displayed.
- 3 Press **3D SURROUND** to switch virtual 3D surround either on or off.
  - A light indicates if virtual 3D surround is on.
- 4 Press **SURROUND ON/OFF** to switch off the surround sound.
  - *SURROUND OFF* is scrolled.

## Surround sound settings

### HALL

The sound reproduction is enhanced and a slight echo is added. This gives the impression of being in a large room. Can only be used in stereo mode.

### SURROUND

The surround mode enables normal surround sound reproduction with 4 or 5 speakers. Depending on the source material, Dolby Surround Pro Logic, Dolby Digital or MPEG is reproduced.

### PRO LOGIC, DOLBY DIGITAL, MPEG

In addition to *SURROUND*, the surround mode used – depending on the source material – will be displayed. In case of digital surround, the sound format AC-3 (for Dolby Digital) or MPEG (for MPEG 2 Multichannel) will be displayed, followed by the sound channels, available on the source (e. g. DVD).

Example: *AC-3 3/2.1* Dolby Digital, 3 front channels, 2 surround channels and a subwoofer channel.  
*MPEG 2/0.0* MPEG Multichannel, stereo sound only.  
*AC-3 3/1.0* Dolby Digital, 3 front channels, 1 (mono) surround channel without subwoofer signal.

### FRONT-3 STEREO

The surround sound is muted. 3 Stereo lets you listen to surround sound without using the surround speakers.

### 3D SURROUND

The sound of the rear channel is simulated by the front speakers. Surround sound is simulated through the front left, right and center speakers. The position of the listener influences the surround effect. The area where the effect is best is shown in grey.

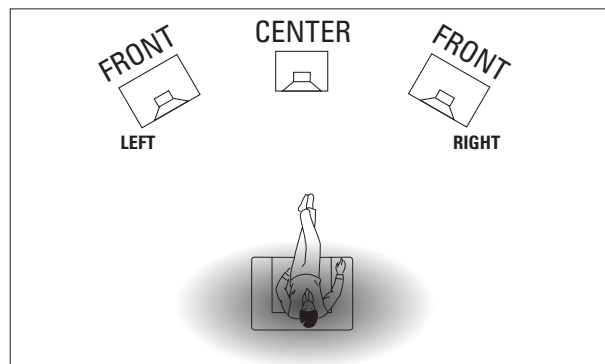

### STEREO

All sound is reproduced and played through the front left and right speakers. This enables standard stereo reproduction.

### NIGHT MODE (only on the remote control)

The loud parts of the sound are lowered and the soft passages are raised. You can enjoy surround sound without disturbing sleeping children or neighbours. Night mode only works with Dolby Digital and MPEG, and only if supported by the source material.

## Tuning to radio stations

You can search for radio stations by scanning the frequency band. You can also key in the frequency of a known radio station. If an FM station is being broadcast and received in stereo, **STEREO** is shown.

### Searching for radio stations

- 1 Turn SOURCE SELECTOR to select the tuner.  
→ **TUNER** is displayed.
  - 2 Select a waveband by pressing TUNER AM/FM repeatedly.  
→ The selected waveband is displayed.
  - 3 Keep ◀ or ▶ pressed for approximately 1 second.  
→ **SEARCH** is displayed and the tuner tunes to a station with sufficient strength.
  - 4 Repeat this procedure until you find the desired station.
- To fine tune to a weak transmitter, briefly press ◀ or ▶ as often as necessary for optimum reception.

### Tuning to a radio station by frequency (with the remote control only)

- 1 Press TUNER.  
→ **TUNER** is displayed.
- 2 Press FR. D..  
→ **\_** is displayed.
- 3 Use 1–0 to key in the frequency of a radio station.

*Note: Only valid numbers within the frequency range of the tuner can be keyed in.*

## Switching FM sensitivity

You can switch the tuner to a lower search sensitivity, to search only for stations with a strong signal (FM only).

- 1 Turn SOURCE SELECTOR to select the tuner.  
→ **TUNER** is displayed.
- 2 Press SENS. on the receiver.  
→ Either **SENS HI** or **SENS LO** is displayed for 5 seconds.

*Note: While searching for radio stations, the actual sensitivity is displayed. In this case, **SENS LO** means the tuner is only looking for radio stations with a strong signal.*

## Storing radio stations

You may store up to 30 radio stations in the memory. The receiver can select and program radio stations by itself or you can choose them yourself.

### Automatic programming

- 1 Choose \* **TUNER** from the menu and press NEXT ▶.
- 2 Choose **AUTO INSTALL** and press NEXT ▶.  
→ The preset number where programming will start, the waveband and **AUTO** are displayed.
- 3 Turn TUNER PRESET ⬇ to change the preset number where programming should start.
- 4 Use TUNER AM/FM to switch to the desired waveband.
- 5 Press ENTER / OK to start programming.  
→ **AUTO INSTALL** flashes and all available radio stations are programmed, this may take a few minutes. Programming is done when **AUTO INSTALL** stops flashing.

### Manual programming

- 1 Choose \* **TUNER** from the menu and press NEXT ▶.
- 2 Choose **MAN INSTALL** and press NEXT ▶.  
→ A preset number, the waveband and the frequency are displayed.
- 3 Turn TUNER PRESET ⬇ to change to the preset number where the radio station should be stored.
- 4 Tune to the desired radio station (see "Searching for radio stations").
- 5 Press ENTER / OK to confirm your selection.  
→ **STORE** is displayed briefly. The radio station is programmed at the chosen preset number.
- 6 Select and store all desired radio stations this way.

### Tuning to stored radio stations

- 1 Turn SOURCE SELECTOR to TUNER to select the tuner.  
→ TUNER is displayed.
- 2 Turn TUNER PRESET  $\blacklozenge$  to select a preset radio station.  
→ PRESET, the preset number and station are displayed.

### Resorting stored radio stations

After programming radio stations, you might want to change their sequence. RESHUFFLE allows you to exchange the positions of presets.

- 1 Choose \* TUNER from the menu and press NEXT  $\blacktriangleright$ .
- 2 Choose RESHUFFLE and press NEXT  $\blacktriangleright$ .  
→ PRESET, a preset number and station are displayed.
- 3 Turn TUNER PRESET  $\blacklozenge$  to select a preset station.
- 4 Press ENTER / OK to confirm the selection.  
→ The selected preset number SWAP (↔) and a second preset number are displayed.
- 5 Turn TUNER PRESET  $\blacklozenge$  to select the other preset station.
- 6 Press ENTER / OK to confirm the exchange.  
→ RESHUFFLE is displayed briefly and these two preset numbers are swapped.

### Naming radio stations

It is possible to assign a name to any of the preset radio stations. RDS station names also can be overwritten.

- 1 Choose \* TUNER from the menu and press NEXT  $\blacktriangleright$ .
- 2 Choose GIVE NAME and press NEXT  $\blacktriangleright$ .  
→ A preset radio station is displayed.
- 3 Turn TUNER PRESET  $\blacklozenge$  to select the preset to be renamed.
- 4 Press ENTER / OK to confirm your selection.  
→ The existing name or \_\_\_\_\_ is displayed.
- 5 Turn TUNER PRESET  $\blacklozenge$  to select a letter and NEXT  $\blacktriangleright$  or  $\blacktriangleleft$  PREV. to move to the next or previous position.
- 6 After you have entered the entire name, press ENTER / OK to confirm.  
→ STORE is displayed and the name is stored.

*Note: If you want to use the transmitted RDS station name again, simply clear the given name.*

### Clearing station names

- 1 Use the menu option \* TUNER, choose GIVE NAME.  
→ A preset radio station is displayed.
- 2 Turn  $\blacklozenge$  MENU NAVIGATOR to select the name to be cleared.
- 3 Press ENTER / OK to confirm your selection.
- 4 Press  $\blacktriangleleft$  PREV. while the first letter is flashing.  
→ CL is flashing to the left of the station name.
- 5 Press ENTER / OK to clear the station name.  
**Or, if you have changed your mind,**  
press  $\blacktriangleleft$  PREV. to leave the station name as it is.

## RDS

**Radio Data System** is a service that allows FM stations to send additional information. If you are receiving an RDS station,  and the station name are displayed.

### Switching through different RDS information

- Press RADIO TEXT on the receiver repeatedly to switch through the following information (if available):
  - Radio text messages
  - RDS clock
  - Frequency
  - Station name

*Note: The time signal broadcasted from certain RDS stations may not always be accurate.*

## RDS News and Traffic Announcement

It is possible to set up the tuner in such a way that any playback is interrupted by news or traffic information of a chosen RDS station. Announcement functions only work if the necessary RDS signals are being broadcast.

If RDS stations are also carrying an EON signal (**E**nhanced **O**ther **N**etworks), **EON** is displayed. This signal enables the tuner to search not only the chosen RDS station, but the whole EON station network for news and traffic information.

- 1 Tune to the desired RDS station.
- 2 Press NEWS/TA:
  - Once** to display **NEWS**, this switches on the news announcement function.
  - Twice** to display **TA**, this switches on the traffic announcement function.
  - Three times** to display **TA** and **NEWS**, this switches on both announcement functions.
- 3 Select and play any other source as usual.
  - While news or traffic information is being broadcast the receiver will switch to tuner and **NEWS** or **TA** will flash.
- 4 Press NEWS/TA until the display indication disappears to switch off the function(s).
  - or**
  - Press NEWS/TA during an announcement to switch off the function(s).

*Note: Be sure to switch the news and traffic announcement off during recording, otherwise these announcements also will be recorded.*

## Receiver

Subject to modification without notice.

### General

Power consumption (FR 960).....	≈ 170 W
Power consumption (FR 970).....	≈ 195 W
Standby power consumption.....	< 2 W
Dimensions, w × h × d.....	435 × 135 × 350 mm
Weight (FR 960).....	8.6 kg
Weight (FR 970).....	9.4 kg

### Amplifier part (0.7 % THD, 6 Ω, 1 kHz)

Output power, stereo mode (FR 960) (DIN).....	2 × 50 W
Output power, surround mode (FR 960)	
Front.....	2 × 50 W
Center.....	50 W
Surround.....	2 × 50 W
Output power, stereo mode (FR 970) (DIN).....	2 × 100 W
Output power, surround mode (FR 970)	
Front.....	2 × 100 W
Center.....	100 W
Surround.....	2 × 50 W
Bass.....	±9 dB at 100 Hz
Treble.....	±9 dB at 10 kHz
Loudness.....	+6 dB at 100 Hz (-30 dB); +3 dB at 10 kHz (-30 dB)
Total harmonic distortion.....	0.05 % at 1 kHz, 1 W
Frequency response.....	20–30,000 Hz, ±1 dB
S/N ratio.....	≥ 82 dB
Stereo separation (1 kHz).....	≥ 45 dB
Crosstalk (1 kHz).....	≤ -65 dB
Digital sampling frequency.....	32 kHz, 44.1 kHz, 48 kHz

### Inputs

Linear inputs.....	250 mV at 47 kΩ
Front AV (FR 970 only).....	250 mV at 22 kΩ
Phono.....	5 mV at 47 kΩ
Digital coaxial.....	75 Ω acc. IEC 958

### Outputs

Power supply AC outlets (switched).....	totally max. 100 W
Linear outputs.....	250 mV at 1 kΩ
Digital coaxial.....	75 Ω acc. IEC 958
Digital optical.....	Toslink
Subwoofer pre-out.....	0.8 V at 1 kΩ
Center pre-out.....	0.8 V at 1 kΩ
Headphones.....	8–600 Ω (3 V e.m.f., 60 Ω)
Speakers.....	≥ 6 Ω

### Tuner part

Wave range	
FM.....	87.5–108.0 MHz
MW.....	531–1,602 kHz
LW.....	153–279 kHz
Sensitivity	
Stereo FM.....	41 dBf
Mono FM.....	15 dBf
Total harmonic distortion	
Stereo FM.....	0.3 %
Mono FM.....	0.85 %
Frequency response.....	63–12,500 Hz ±1 dB
S/N ratio	
Stereo FM.....	55 dB
Mono FM.....	60 dB
Channel separation.....	35 dB at 1 kHz

## WARNING

**Under no circumstances should you try to repair the set yourself as this will invalidate the guarantee. Do not open the set as there is a risk of electric shock.**

If a fault occurs, first check the points listed, before taking the set for repair.

If you are unable to solve a problem by following these hints, consult your dealer or service centre.

PROBLEM	POSSIBLE CAUSE	SOLUTION
<b>No sound</b>	VOLUME is not correctly adjusted.	Adjust the VOLUME.
	Headphones are connected.	Disconnect headphones.
	The wrong source is selected.	Turn SOURCE SELECTOR to select the correct source.
<b>No sound on the left or right side</b>	One speaker is wrongly connected.	Connect the speaker properly.
	A speaker cable is damaged.	Replace the cable.
	Volume balance in the receiver menu is wrongly adjusted.	Adjust <i>VOL FRONT-L</i> and <i>VOL FRONT-R</i> in the receiver menu.
<b>Poor sound or no sound at the center or surround speakers</b>	SURROUND mode is not switched on.	Press SURROUND ON/OFF to switch on the surround sound.
	Surround and/or center speakers are not (properly) connected.	Connect the speakers properly.
	Surround and/or center speakers are switched off in the <i>SPEAKER SETUP</i> menu.	Set speaker present to <i>YES</i> .
	A speaker cable is damaged.	Replace the cable.
<b>Poor bass sound</b>	Speakers are not in phase.	Connect the coloured (or marked) wires to the coloured terminals and the black (or unmarked) wires to the black terminals.
<b>Bad sound</b>	Badly matching setting for the given type of music or sound.	Correct the sound settings on the receiver.
<b>Surround sound level is too low or too high</b>	The level of the surround sound is not properly adjusted.	Adjust the level of the surround sound on the receiver.
<b>Center sound level is too low or too high</b>	The sound level of the center channel is not properly adjusted.	Adjust the level of the center channel on the receiver.
<b>Only center speaker is heard in Dolby Surround Pro Logic</b>	A mono signal is reproduced.	Choose a different sound source or switch off surround sound.
<b>Bad radio reception, automatic programming does not work properly</b>	Receiver or antenna is positioned near a radiation source such as a TV, CD player, CD recorder, DVD player, etc.	Change the position of the interfering unit or try to switch it off.

**Meet Philips at the Internet**  
**<http://www.philips.com>**

English

Français

Español

Deutsch

Nederlands

Italiano

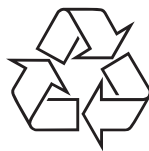



## Free Manuals Download Website

<http://myh66.com>

<http://usermanuals.us>

<http://www.somanuals.com>

<http://www.4manuals.cc>

<http://www.manual-lib.com>

<http://www.404manual.com>

<http://www.luxmanual.com>

<http://aubethermostatmanual.com>

Golf course search by state

<http://golfingnear.com>

Email search by domain

<http://emailbydomain.com>

Auto manuals search

<http://auto.somanuals.com>

TV manuals search

<http://tv.somanuals.com>