

Register your product and get support at
www.philips.com/welcome

HTR5224



EN	User manual	3
DE	Benutzerhandbuch	3
ES	Manual del usuario	3
FR	Mode d'emploi	3
NL	Gebruiksaanwijzing	3

PHILIPS

Contents

1 Important	4
Safety and important notice	4
Trademark notice	5
2 Your product	6
Feature highlights	6
Product overview	6
3 Connect	9
Place the product	9
Connect speakers and subwoofer	10
Connect radio antenna	10
Connect HDMI supported devices	11
Connect other devices	12
Connect power cord	14
4 Get started	15
Insert the remote control batteries	15
Control a play source	15
Change speaker settings	15
Use Philips EasyLink	17
Select a play source	18
5 Play	19
Play from portable media player	19
Play from radio	19
Use sleep timer to power off	20
6 Adjust sound	21
Control the volume	21
Select surround sound	21
Select double bass	21
Select a preset sound effect	22
7 Specifications	23
8 Troubleshooting	24
9 Glossary	25

1 Important

Safety and important notice



Warning

- Risk of overheating! Never install the digital receiver in a confined space. Always leave a space of at least 4 inches around the digital receiver for ventilation. Ensure curtains or other objects never cover the ventilation slots on the digital receiver.
- Never place the digital receiver, remote control or batteries near naked flames or other heat sources, including direct sunlight.
- Only use this digital receiver indoors. Keep this digital receiver away from water, moisture and liquid-filled objects.
- Never place this digital receiver on other electrical equipment.
- Keep away from this digital receiver during lightning storms.
- Where the mains plug or an appliance coupler is used as the disconnect device, the disconnect device shall remain readily operable.
- Visible and invisible laser radiation when open. Avoid exposure to beam.

Mains fuse (UK only)

This Digital Receiver is fitted with an approved moulded plug. Should it become necessary to replace the mains fuse, this must be replaced with a fuse of the same value as indicated on the plug (example 10A).

- 1** Remove fuse cover and fuse.
- 2** The replacement fuse must comply with BS 1362 and have the ASTA approval mark. If the fuse is lost, contact your dealer in order to verify the correct type.
- 3** Refit the fuse cover.

In order to maintain conformity to the EMC directive, the mains plug on this product must not be detached from the mains cord.



This product complies with the radio interference requirements of the European Community.

This product complies with the requirements of the following directives and guidelines: 2004/108/EC, 2006/95/EC

Recycling



Your product is designed and manufactured with high quality materials and components, which can be recycled and reused.

When you see the crossed-out wheeled bin symbol attached to a product, it means the product is covered by the European Directive 2002/96/EC:



Never dispose of your product with other household waste. Please inform yourself about the local rules on the separate collection of electrical and electronic products. The correct disposal of your old product helps prevent potentially negative consequences for the environment and human health.



Your product contains batteries covered by the European Directive 2006/66/EC, which cannot be disposed of with normal household waste.

Please inform yourself about the local rules on the separate collection of batteries. The correct disposal of batteries helps prevent potentially negative consequences for the environment and human health.

Trademark notice



HDMI, HDMI logo and High-Definition Multimedia Interface are trademarks or registered trademarks of HDMI licensing LLC.



Manufactured under license from Dolby Laboratories. Dolby, Pro Logic and the double-D symbol are trademarks of Dolby Laboratories.



Manufactured under license under U.S. Patent #'s: 5,451,942; 5,956,674; 5,974,380; 5,978,762; 6,487,535 & other U.S. and worldwide patents issued & pending. DTS and DTS Digital Surround are registered trademarks and the DTS logos and Symbol are trademarks of DTS, Inc. © 1996-2008 DTS, Inc. All Rights Reserved.



ENERGY STAR and the ENERGY STAR mark are registered U.S. trademarks.

2 Your product

Congratulations on your purchase, and welcome to Philips! To fully benefit from the support that Philips offers; register your product at www.philips.com/welcome.

Feature highlights

Your product supports Philips EasyLink, which uses the HDMI CEC (Consumer Electronics Control) protocol. EasyLink-compliant devices that are connected through HDMI connectors can be controlled by a single remote control.

Note

- Philips does not guarantee 100% interoperability with all HDMI CEC devices.

Listen to rich uncompressed multi-channel surround sound

This product supports 7.1 channels of uncompressed audio that delivers a true-to-life sound experience as if you are listening to it live.

MP3 link

Simply plug your portable media player into the MP3 LINK socket to enjoy the music in superb sound quality.

Sync the audio output with the video play

Synchronise audio from this Digital Receiver with video played from other devices by delaying the audio output from the speakers to match the video on the TV.

Product overview

Main unit

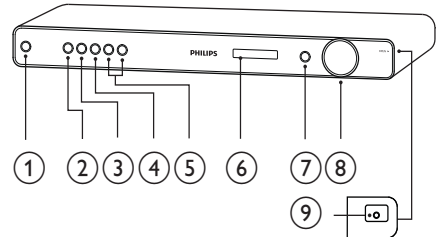

- 1** **⏻ (Standby-On)**
 - Turns on the Digital Receiver or switches to standby mode.
- 2** **SURR (Surround Sound)**
 - Switches audio output to one of these modes: multi-channel 7.1 surround, 7-channel stereo, multi-channel 5.1 surround, 5-channel stereo or stereo.
- 3** **SOUND**
 - Selects a predefined sound effect.
- 4** **PROG (Programme)**
 - In radio mode, resets the list of preset stations: press to manually reset; press and hold to automatically reset.
 - In other source mode, accesses or exits the audio setup mode for speaker settings.
- 5** **◀▶ TUNING**
 - Selects the previous or next preset radio station.
 - Press and hold to start auto search.
- 6** **Display panel**
- 7** **SOURCE**
 - Selects a connected device to enjoy the audio output through the speaker system.

- ⑧ **VOLUME**
 - Increases or decreases volume.
- ⑨ **MP3 LINK**
 - Connects a portable audio player.

Remote Control

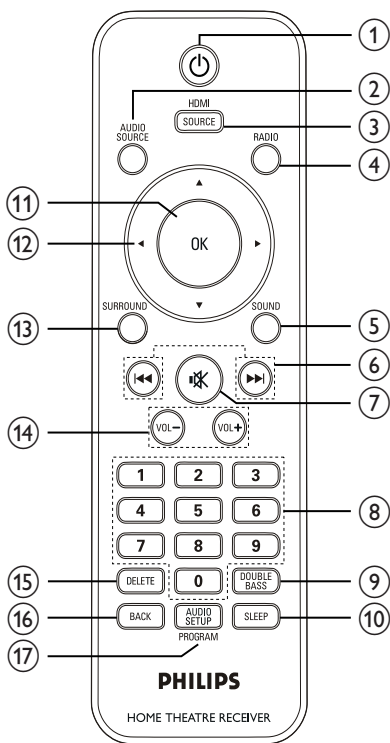

- ① **⏻ (Standby-On)**
 - Turns on the Digital Receiver or switches to standby mode.
- ② **AUDIO SOURCE**
 - Selects an audio input source.
- ③ **HDMI SOURCE**
 - Selects an HDMI input source.
- ④ **RADIO**
 - Switches to FM band.
- ⑤ **SOUND**
 - Selects a predefined sound effect.
- ⑥ **⏮ / ⏭**
 - Selects the previous or next preset radio station.

- ⑦ **⏏ (Mute)**
 - Mutes or restores audio output.
- ⑧ **Numeric buttons**
 - Enter the number of a preset radio station.
- ⑨ **DOUBLE BASS**
 - Turns dynamic bass enhancement on or off.
- ⑩ **SLEEP**
 - Sets a delay after which the Digital Receiver switches to standby.
- ⑪ **OK**
 - Confirms an entry or selection.
- ⑫ **▲▼◀▶ (Navigation buttons)**
 - Navigates through menus.
 - In radio mode, press up and down to tune the radio frequency.
 - In radio mode, press left or right to start auto search.
- ⑬ **SURROUND**
 - Switches audio output to one of these modes: multi-channel 7.1 surround, 7-channel stereo, multi-channel 5.1 surround, 5-channel stereo or stereo.
- ⑭ **VOL +/-**
 - Increases or decreases volume.
- ⑮ **DELETE**
 - Press and hold to erase the current preset radio station.
- ⑯ **BACK**
 - Returns to previous step.
 - Press and hold to delete selected station.
- ⑰ **AUDIO SETUP / PROGRAM**
 - Accesses or exits options for audio settings.
 - In radio mode, resets the list of preset stations: press to manually reset; press and hold to automatically reset.

3 Connect

Make the following connections to use your Digital Receiver.

Connect this Digital Receiver:

- Speakers and subwoofer
- Radio antenna
- Power

Connect other devices:

- HDMI supported devices
- Audio from TV
- Audio from cable box/recorder/game console/disc player
- Portable media player



Note

- Refer to the type plate at the back or bottom of the product for identification and supply ratings.
- Before you make or change any connections, ensure that all the devices are disconnected from the power outlet.



Tip

- Different types of connectors may be used to connect this product to your TV, depending on availability and your needs. A comprehensive interactive guide to help you connect your product is available at www.connectivityguide.philips.com.

Place the product

- Place the product where it cannot be pushed, pulled over or knocked down. Do not place it in an enclosed cabinet.
- Make sure that you have full access to the power cord for easy disconnection of the product from the power supply.

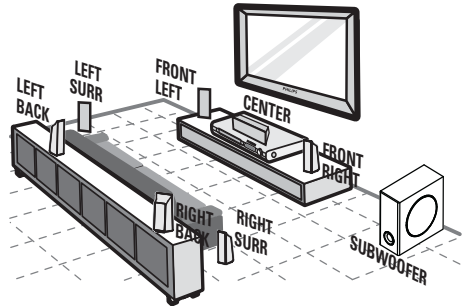

- 1 Place the Digital Receiver near the TV.
- 2 Place the speakers system at normal listening ear-level and directly parallel to the listening area.
- 3 Place the subwoofer in the corner of the room or at least 3 feet away from the TV.



Tip

- To avoid magnetic interference or unwanted noise, never place this Digital Receiver too close to any radiation devices.

Connect speakers and subwoofer

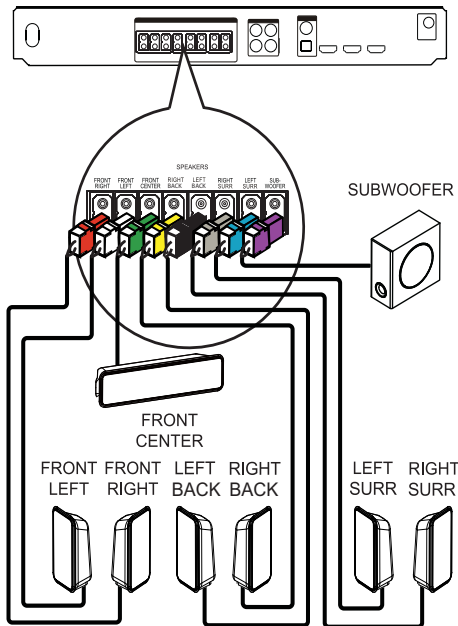

- 1 Connect the speakers and subwoofer to the matching sockets on the Digital Receiver.

Note

- Ensure that the colours of the plugs and sockets are matched.

Connect radio antenna

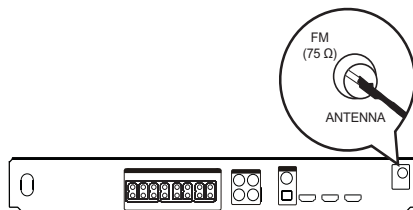

- 1 Connect the FM antenna to the **FM75 Ω** socket on the Digital Receiver (for some models, this cable is already connected).
- 2 Extend the FM antenna and fix its ends to the wall.

Tip

- For better FM stereo reception, connect to an external FM antenna.

Connect HDMI supported devices

Connect to HDTV

Connect this Digital Receiver to your High Definition TV (HDTV) to enjoy Philips EasyLink control capabilities. You can synchronise operations with other HDMI compatible devices. See 'Get Started' chapter > 'Use Philips EasyLink' for details.

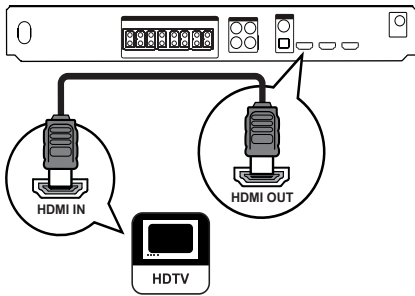

- 1 Connect an HDMI cable (not supplied) to the **HDMI OUT** on the Digital Receiver and the **HDMI IN** socket on the HDTV.
- 2 Connect an audio cable (analogue or digital) to the **AUDIO IN-AUX1/AUX2** sockets or **DIGITAL IN** socket on the Digital Receiver and the corresponding audio input sockets on the HDTV.
 - See 'Connect other devices' chapter > 'Connect audio from TV' for details.

Note

- You can only use the Philips EasyLink control if the connected HDTV and HDMI compatible devices are compliant with HDMI-CEC.

Connect to HDMI devices

Connect the HDMI or DVI compatible devices (e.g. DVD/Blu-ray player, HDD/DVD recorder) to this Digital Receiver to enjoy uncompressed digital audio output.

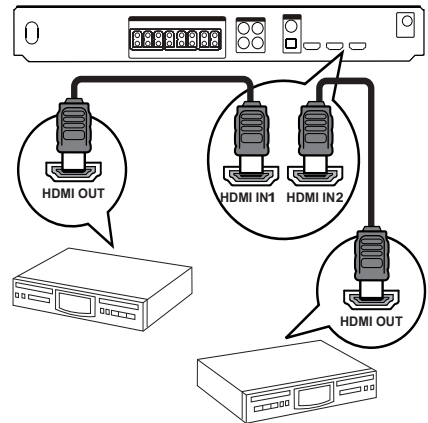

- 1 Connect an HDMI cable (not supplied) to the **HDMI IN1/HDMI IN2** socket on the Digital Receiver and the **HDMI OUT** socket on the device.

Note

- To listen to the audio output from this connection, press **HDMI SOURCE** repeatedly to select 'HDMI IN1' or 'HDMI IN2'.

Connect other devices

Route the audio from other devices to this Digital Receiver to enjoy audio with multi-channel surround capabilities.

Connect audio to TV

(also used for EasyLink control)

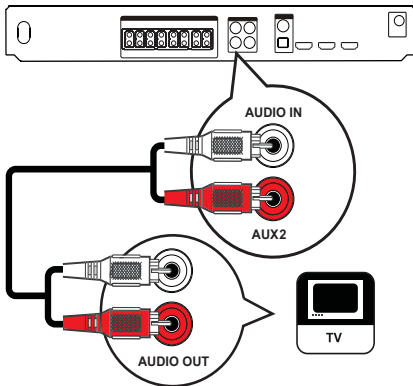

- 1 Connect the audio cable (not supplied) to the **AUDIO IN-AUX2** sockets on the Digital Receiver and the **AUDIO OUT** sockets on your TV.

Note

- To listen to the audio output from this connection, press **AUDIO SOURCE** repeatedly until 'AUX2' is displayed on the display panel.

Tip

- If the TV has a digital audio output socket (Coaxial or Optical), you can connect it to the corresponding input socket on the Digital Receiver for better sound quality.

Connect audio from cable box/ recorder/game console/disc player

You can choose to connect to analogue or digital sockets depending on the device capabilities.

Connect to analogue sockets

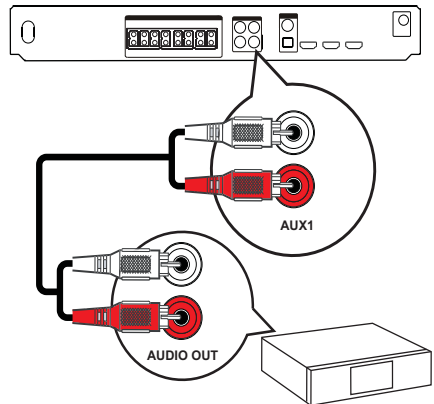

- 1 Connect the audio cables (not supplied) to the **AUDIO IN-AUX1** sockets on the Digital Receiver and the **AUDIO** output sockets on the device.

Note

- To listen to the audio output from this connection, press **AUDIO SOURCE** repeatedly until 'AUX1' is displayed on the display panel.

Connect to coaxial socket

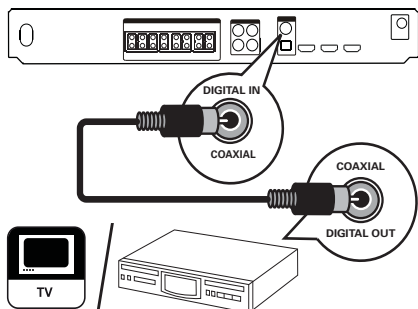

- 1 Connect a coaxial cable (not supplied) to the **COAXIAL DIGITAL-IN** socket on the Digital Receiver and the **COAXIAL/DIGITAL** output socket on the device.

Note

- To listen to the audio output from this connection, press **AUDIO SOURCE** repeatedly until 'COAX IN' is displayed on the display panel.

Connect to optical socket

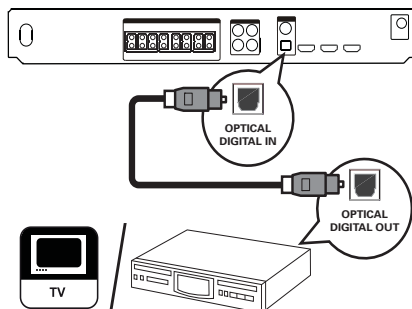

- 1 Connect the optical cable to the **OPTICAL DIGITAL-IN** socket on the Digital Receiver and the **OPTICAL/SPDIF** output socket on the device.

Note

- To listen to the audio output from this connection, press **AUDIO SOURCE** repeatedly until 'OPTI IN' is displayed on the display panel.

Connect portable media player

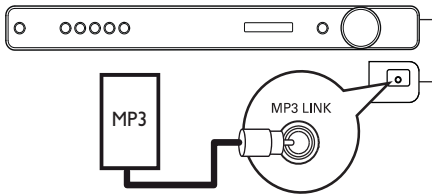

- 1 Connect a 3.5 mm stereo audio cable (not supplied) to the **MP3 LINK** socket on the Digital Receiver and the phone socket on the portable media player (e.g. MP3 player).



Note

- To listen to the audio output from this connection, press **AUDIO SOURCE** repeatedly until 'MP3 LINK' is displayed on the display panel.

Connect power cord



Warning

- Risk of product damage! Ensure that the power supply voltage corresponds to the voltage printed on the back or the underside of the product.

- 1 Connect the power cord to the socket when all the required connections are made.
 - ↳ This product is ready to be set up for use.

4 Get started

Insert the remote control batteries

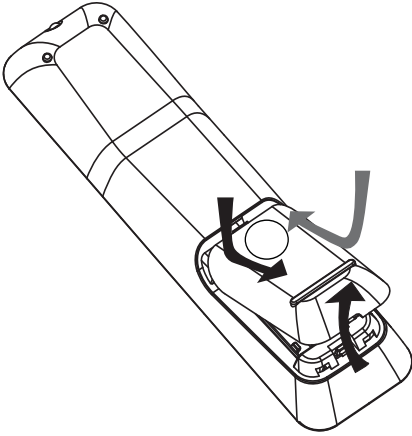

- 1 On the back of the remote control, slide the battery cover to remove it.
- 2 Insert the 2 supplied batteries (AAA). Be sure the + and - ends of the batteries line up with the markings inside the case.
- 3 Slide the cover back into position.

Note

- Do not mix batteries (old and new or carbon and alkaline, etc.).
- Remove batteries if they are exhausted or if the remote control is not to be used for a long time.
- Batteries contain chemical substances, they should be disposed of properly.

Control a play source

- 1 Press **RADIO**, **AUDIO SOURCE** or **HDMI SOURCE** to select the source you wish to control.
- 2 Adjust the volume or change the sound/surround effect.

Change speaker settings

Ideally, the distance between listening position and all the speakers should be the same. If not, change the speaker settings based on their distance from the listening position to obtain the best possible surround sound.

Note

- Switch this Digital Receiver to multi-channel surround mode before you can change the speaker settings.

Test and set the speaker volume

- 1 Press **SURROUND** to switch to multi-channel surround mode.
- 2 Press **AUDIO SETUP**.
- 3 Press **◀◀ / ▶▶** until 'TEST TONE' is displayed, then press **OK**.
 - ↳ Each speaker outputs sound for 5 seconds. You can hear the volume level set for each speaker.
- 4 Press **▲▼** or **VOL +/-** to adjust the volume level, then press **OK**.
 - The last volume setting will be stored automatically after 5 seconds of inactivity.
- 5 Repeat the above steps for other speakers until the output level of all speakers is equally balanced.
 - To return to previous step, press **BACK**.
 - To exit the setup, press **AUDIO SETUP**.

Note

- If no buttons are pressed within 2 seconds after one speaker has been tested, the next speaker will be tested automatically.
- Test tone is available only in Multi-channel 7.1 and Multi-channel 5.1 modes.

Set the speaker delay time

- 1 Press **SURROUND** to switch to multi-channel surround mode.
- 2 Press **AUDIO SETUP**.
- 3 Press **◀▶** to select the speaker for which you want to set the delay time, then press **OK**.
 - ↳ 'CENTER DELAY' - for centre speaker.
 - ↳ 'SURROUND DELAY' - for surround speakers.
 - ↳ 'BACK DELAY' - for back (rear) speakers.
- 4 Press **▲▼** or adjust the volume control to increase or decrease the delay time, then press **OK**.
 - The last volume setting will be stored automatically after 5 seconds of inactivity.
- 5 Repeat steps 3 - 4 for other speaker settings.
 - To return to previous step, press **BACK**.
 - To exit the setup, press **AUDIO SETUP**.



Note

- This setting is only applicable to centre, back and surround speakers.
- Set a longer delay time if the centre, back or surround speakers are closer to the listening position than the front speakers.
- Rear and centre delays range from 0 to 15 MS. The default setting is 0 MS.

Sync audio output with video play

- 1 Press **SURROUND** to switch to multi-channel surround mode.
- 2 Press **AUDIO SETUP**.
- 3 Press **◀▶** until 'AUDIO SYNC' is displayed, then press **OK**.
- 4 Press **VOL +/-** within 5 seconds to set the delay time for audio output.
 - To return to previous step, press **BACK**.
 - To exit the setup, press **AUDIO SETUP**.



Tip

- If the volume control is not adjusted within 10 seconds, it resumes normal volume control function.

Use Philips EasyLink

Your product supports Philips EasyLink, which uses the HDMI CEC (Consumer Electronics Control) protocol. EasyLink-compliant devices that are connected through HDMI connectors can be controlled by a single remote control.

Note

- Philips does not guarantee 100% interoperability with all HDMI CEC devices.

- Press **AUDIO SETUP**.
- Press **◀▶** repeatedly to select one of the Philips EasyLink features: 'EASYLINK' > 'ONE-TOUCH STANDBY' > 'SYSTEM AUDIO CONTROL' > 'TV AUDIO INPUT', then press **OK**.

EasyLink

Turns all EasyLink features off or on (see below).

One-touch standby

When you press and hold **STANDBY** for three seconds, all the connected HDMI CEC devices switch to standby simultaneously. You can also perform one-touch standby using the remote control for any of the connected HDMI devices.

To disable this feature, select '**OFF**'.

System audio control

When you play from the connected HDMI CEC device, this Digital Receiver switches automatically to the corresponding audio source. You can use the remote control for any of the connected HDMI devices to adjust the volume.

To use this feature, select '**ON**'. Then proceed to '**TV AUDIO INPUT**' to map the audio input of this Digital Receiver to the TV.

TV audio input

Selects the audio socket used to connect this Digital Receiver to the TV. When you select the audio input correctly, this Digital Receiver switches automatically to the audio input from the device that is playing.

- Press **▲▼** to change the settings, then press **OK**.
 - To exit the setup, press **AUDIO SETUP**.

Note

- You must turn on the HDMI CEC operations on the TV/devices before you can enjoy the EasyLink controls. See the TV/devices manual for details.
- Dual sound may hear from TV and this Digital Receiver if the 'TV AUDIO INPUT' mapping is not done properly.

Select a play source

On the main unit

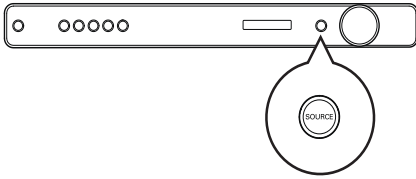

- 1 Press the **SOURCE** button repeatedly to select: COAX IN > OPTI IN > AUX1 > AUX2 > MP3 LINK > FM > HDMI IN1 > HDMI IN2.

On the remote control

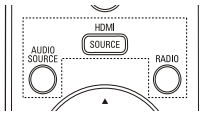

- Press **AUDIO SOURCE** repeatedly to listen to the audio output from the connected device.

Display	Device connected to
AUX1	AUDIO IN-AUX1 sockets.
AUX2	AUDIO IN-AUX2 sockets.
COAX IN	DIGITAL IN-COAXIAL socket.
OPTI IN	DIGITAL IN-OPTICAL socket.
MP3 LINK	MP3 LINK socket.

- Press **HDMI SOURCE** to select the device that is connected to the HDMI IN1 or HDMI IN2 socket.
- Press **RADIO** to switch to FM band.

5 Play

Play from portable media player

Simply connect your portable media player (e.g. MP3 player) to the Digital Receiver to enjoy superb sound quality from your music collection.

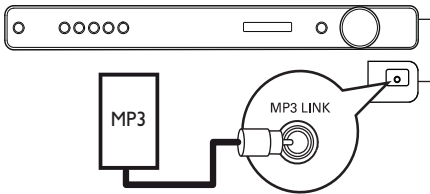

- 1 Connect a 3.5 mm stereo audio cable (not supplied) from the **MP3 LINK** socket on the Digital Receiver to the 'headphone' socket on the portable media player.
- 2 Press **AUDIO SOURCE** repeatedly until 'MP3 LINK' is displayed.
- 3 Start play on your portable media player.
 - To stop play, press **STOP** on the portable media player.

Note

- Control playback is only possible on the portable media player.
- Stop play on the portable media player before you switch to other play media/source.

Play from radio

Check that the FM antenna has been connected to the Digital Receiver. If not, connect the supplied FM antenna to the **FM75 Ω** socket and fix its ends to the wall.

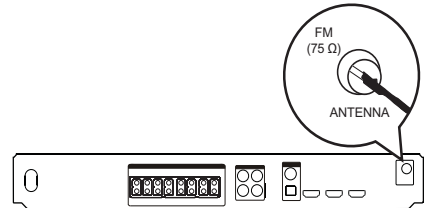

Tip

- For better FM stereo reception, connect an external FM antenna (not supplied).
- Position the antenna as far away as possible from your TV, VCR or other radiation source to prevent interference.

First time tuning

When you access radio mode for the first time, follow the instructions to install the radio stations.



- 1 Press **RADIO**.
 - ↳ 'AUTO INSTALL ... PRESS OK' is displayed.
- 2 Press **OK**.
 - ↳ All detected radio stations are stored.
 - ↳ Once complete, it tunes to the first preset radio station.
 - To stop auto tuning, press **BACK**.

Note

- This Digital Receiver can store up to a maximum of 40 radio stations.
- If auto installation is not activated or less than 5 radio stations are stored, you will be prompted to install the radio stations again.

Listen to radio

- 1 Press **RADIO**.
- 2 Use the remote control to control the radio.

Button	Action
	Selects a preset radio station.
	Tunes the radio frequency up or down.
DELETE	Press and hold to delete the current radio station from the preset list. The preset number for other radio stations remain unchanged.



Note

- If the FM radio station transmits RDS (Radio Data System) data, the name of the radio station is displayed.

Reinstall all the radio stations



- 1 Press **RADIO**.
- 2 Press and hold **PROGRAM** for more than 5 seconds.
 - ↳ All previously stored radio stations are replaced.



Note

- Check the radio antenna connection if no stereo signal is detected or less than 5 stations are detected during radio installation.

Search and store radio stations individually

- 1 Press **RADIO**.
- 2 Press 
 - ↳ It starts searching until a radio station is detected.
 - ↳ To fine-tune the radio frequency, press .
- 3 Press **PROGRAM**.
 - ↳ The preset station number blinks.
 - ↳ If no action is carried out within 20 seconds after the above step, it exits the preset mode.
- 4 Press  (or the **Numeric buttons**) to select a preset number to store.
- 5 Press **PROGRAM** to confirm.



Use sleep timer to power off

Use the sleep timer feature to switch this Digital Receiver to standby automatically after the preset time.

- 1 Press **SLEEP** repeatedly to select the countdown time before power off.
 - ↳ '60 > 45 > 30 > 15 > OFF' is displayed.
 - To cancel the sleep timer, select 'OFF'.
 - If the timer has been set, press **SLEEP** to view the time left or press repeatedly to set a new power off time.

6 Adjust sound

Control the volume

- 1 Press **VOL +/-** to increase or decrease the volume.
 - To mute, press .
 - To restore the volume, press  again or press **VOL +**.

Select surround sound

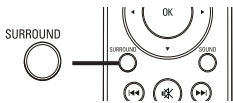

- 1 Press **SURROUND** repeatedly to select the best surround output available on the disc or the surround output best suited to the music that you play.

Option	Description
MULTI-CHANNEL 7.1 / MULTI-CHANNEL 5.1	Multi-channel surround output: DTS (Digital Theater System), Dolby Digital and Dolby Pro Logic II/IIx.
SURROUND	
5CHANNEL / 7CHANNEL STEREO	Enhances the stereo channel output by duplicating the sound output to the centre and rear speakers. Ideal for party music.
STEREO	Stereo sound.

Select double bass

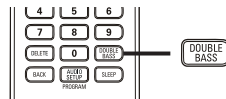

- 1 Press **DOUBLE BASS** to turn the double bass mode on or off.

Note

- Double Bass is used to increase the resonance of the bass effect, not the bass power level. It is designed to enhance movies sound effect.

Select a preset sound effect

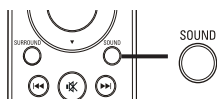

- 1 Press **SOUND** repeatedly to select the most suitable sound effect for the video or music that you are playing.

Movie / Music	Description
CONCERT / CLASSIC	Flat and pure sound mode. Ideal for listening to classical music and watching live concert discs.
DRAMA / JAZZ	Moderate sound mode suitable for lounge music and watching dramas.
ACTION / ROCK	Enhanced low and high range for great sounding movie effects and atmosphere. Great for action movies and rock/pop music.
SPORTS	Moderate mid-range and surround effects for clear vocals and the atmosphere of a live sports venue. Also ideal for video gaming.
NIGHT	Dynamically controlled sound mode suitable for watching movies at night or for non-intrusive background music.

Note

- For stereo mode with compressed data (e.g. MP3), it is automatically set to the full sound mode. Therefore, no differences with the sound effect when you select different sound mode.

7 Specifications



Note

- Specification and design are subject to change without notice

Amplifier

- Total output power: 1000 W RMS
- Frequency response: 40 Hz-20 kHz
- Signal-to-noise ratio: > 60 dB (A-weighted)
- Input sensitivity
 - AUX 1 & 2: 400 mV
 - MP3 LINK: 250 mV

Radio

- Tuning range: FM 87.5-108 MHz
- 26 dB quieting sensitivity: FM 22 dBf
- Signal-to-noise ratio: FM 55 dB
- Harmonic distortion: FM 3%
- Frequency response: FM 180 Hz-10 kHz / ± 6 dB
- Stereo Threshold: FM 29 dB

Main unit

- Power supply: 220-240 V; ~ 50 Hz
- Power consumption: 120 W
- Dimensions (WxHxD): 435 x 57 x 365 (mm)
- Weight: 3.36 kg

Speakers

- System: full range satellite
- Speaker impedance: 4 ohm (centre), 8 ohm (Front/Back/Surround)
- Speaker drivers: 3" full range.
- Frequency response: 150 Hz-20 kHz
- Dimensions (WxHxD):
 - Centre: 244 x 103 x 74 (mm)
 - Front/Back/Surround: 103 x 203 x 71 (mm)
- Weight
 - Centre: 0.79 kg
 - Front: 0.54 kg
 - Back/Surround: 0.44 kg

Subwoofer

- Impedance: 4 ohm
- Speaker drivers: 165 mm (6.5") woofer
- Frequency response: 40 Hz-150 Hz
- Dimensions (WxHxD): 163 x 363 x 369 (mm)
- Weight: 4.7 kg

8 Troubleshooting



Warning

- Risk of electric shock. Never remove the casing of the product.

To keep the warranty valid, never try to repair the product yourself.

If you encounter problems when using the product, check the following points before requesting service. If the problem remains unsolved, register your product and get support at www.philips.com/welcome.

If you contact Philips, you will be asked for the model and serial number of your Digital Receiver. The model number and serial number are on the back or underside of your Digital Receiver. Write the numbers here:

Model No. _____

Serial No. _____

Main unit

No reaction to the remote control.

- Disconnect this product from the socket for a few minutes, then connect again.
- Point the remote control at the product.
- Insert the batteries correctly.
- Insert new batteries if necessary.

Sound

No sound.

- Ensure that the audio or HDMI cables are connected and press **AUDIO SOURCE** or **HDMI SOURCE** to select the correct input source.

Poor radio reception.

- If the signal is too weak, adjust the antenna or connect an external antenna for better reception.
- Place the antenna further away from any equipment that may cause interference.

No output from the Set-Top Box.

- Not all the Set-Top-Box supports output through HDMI receiver. Check with the respective manufacturer for the HDMI output support.

Dual sound is heard from TV and this Digital Receiver.

- Check if you have done the 'TV AUDIO INPUT' mapping correctly, see 'Getting Started' > 'Use Philips EasyLink'.
- Turn off the 'EASYLINK' feature, see 'Getting Started' > 'Use Philips EasyLink'.

9 Glossary

A

Analogue audio

An electrical signal that directly represents sound. Same as digital audio, which may be an electrical signal, but is an indirect representation of sound. Analogue sound varies, while digital sound has specific numerical values.

D

Dolby Digital

A surround sound system developed by Dolby Laboratories that contains up to six channels of digital audio (front left and right, surround left and right, centre and subwoofer.)

Dolby Digital Pro Logic II

An advanced, matrix decoding technology that expands any two channel audio, such as CDs and stereo encoded videocassettes, video games and TV broadcasts to a five channel full bandwidth (range) playback (Left/Centre/Right/Left Surround/Right Surround), resulting in a surround sound experience.

DTS

Digital Theatre Systems. A surround sound system for providing 5.1 and 7.1 channels of discrete digital audio in consumer electronics products and software content. It is not developed by Dolby Digital.

H

HDMI

High-Definition Multimedia Interface is a high-speed digital interface that can transmit uncompressed high definition video and digital multichannel audio. It delivers high quality picture and sound quality, completely free from noise. HDMI is fully backward-compatible with DVI.

As required by the HDMI standard, connecting to HDMI or DVI products without HDCP (High-bandwidth Digital Content Protection) will result in no Video or Audio output.

M

MP3

A file format with a sound data compression system. MP3 is the abbreviation of Motion Picture Experts Group 1 (or MPEG-1) Audio Layer 3. With the MP3 format, one CD-R or CD-RW can contain about 10 times more data than a regular CD.

Multichannel

Usually DVD is specified to have each sound track constitute one sound field. Multichannel refers to a structure of sound tracks having three or more channels.

S

Stereo

Literally means solid. Usually taken to refer to two channel stereo, though developments in digital audio facilitate multichannel stereo.

Surround

A system that creates realistic, three-dimensional sound fields. It is usually achieved with multiple speakers that are arranged around the listener.

Free Manuals Download Website

<http://myh66.com>

<http://usermanuals.us>

<http://www.somanuals.com>

<http://www.4manuals.cc>

<http://www.manual-lib.com>

<http://www.404manual.com>

<http://www.luxmanual.com>

<http://aubethermostatmanual.com>

Golf course search by state

<http://golfingnear.com>

Email search by domain

<http://emailbydomain.com>

Auto manuals search

<http://auto.somanuals.com>

TV manuals search

<http://tv.somanuals.com>