

Digital surround sound receiver

FR960
MX975D



Toll Free Help Line

Ligne d'assistance en service libre
Línea de ayuda telefónica sin cargo

800-531-0039



Let's make things better.



PHILIPS

Return your Warranty Registration card today to ensure you receive all the benefits you're entitled to.

• Once your Philips purchase is registered, you're eligible to receive all the privileges of owning a Philips product.

• So complete and return the Warranty Registration Card enclosed with your purchase at once. And take advantage of these important benefits.

Warranty Verification

Registering your product within 10 days confirms your right to maximum protection under the terms and conditions of your Philips warranty.

Owner Confirmation

Your completed Warranty Registration Card serves as verification of ownership in the event of product theft or loss.

Model Registration

Returning your Warranty Registration Card right away guarantees you'll receive all the information and special offers which you qualify for as the owner of your model.

PHILIPS

Congratulations on your purchase, and welcome to the "family!"

Dear Philips product owner:

Thank you for your confidence in Philips. You've selected one of the best-built, best-backed products available today. And we'll do everything in our power to keep you happy with your purchase for many years to come.

As a member of the Philips "family," you're entitled to protection by one of the most comprehensive warranties and outstanding service networks in the industry.

What's more, your purchase guarantees you'll receive all the information and special offers for which you qualify, plus easy access to accessories from our convenient home shopping network.

And most importantly you can count on our uncompromising commitment to your total satisfaction.

All of this is our way of saying welcome—and thanks for investing in a Philips product.

Sincerely,



Robert Minkhorst
President and Chief Executive Officer

P.S. Remember, to get the most from your Philips product, you must return your Warranty Registration Card within 10 days. So please mail it to us right now!



Know these *safety* symbols



 This "bolt of lightning" indicates uninsulated material within your unit may cause an electrical shock. For the safety of everyone in your household, please do not remove product covering.

 The "exclamation point" calls attention to features for which you should read the enclosed literature closely to prevent operating and maintenance problems.

WARNING: TO PREVENT FIRE OR SHOCK HAZARD, DO NOT EXPOSE THIS EQUIPMENT TO RAIN OR MOISTURE.

CAUTION: To prevent electric shock, match wide blade of plug to wide slot, and fully insert.

For Customer Use

Enter below the Serial No. which is located on the rear of the cabinet. Retain this information for future reference.

Model No. _____

Serial No. _____

English2

English

Français.....27

Français

Español51

Español

Canada

English: This digital apparatus does not exceed the Class B limits for radio noise emissions from digital apparatus as set out in the Radio Interference Regulations of the Canadian Department of Communications.

Français : Cet appareil numérique n'émet pas de bruits radioélectriques dépassant les limites applicables aux appareils numériques de Classe B prescrites dans le Règlement sur le Brouillage Radioélectrique édicté par le Ministère des Communications du Canada.

IMPORTANT SAFETY INSTRUCTIONS – Read before operating equipment

This product was designed and manufactured to meet strict quality and safety standards. There are, however, some installation and operation precautions which you should be particularly aware of.

- 1. Read these instructions** – All the safety and operating instructions should be read before the appliance is operated.
- 2. Keep these instructions** – The safety and operating instructions should be retained for future reference.
- 3. Heed all warnings** – All warnings on the appliance and in the operating instructions should be adhered to.
- 4. Follow all instructions** – All operating and use instructions should be followed.
- 5. Do not use this apparatus near water** – for example, near a bathtub, washbowl, kitchen sink, laundry tub, in a wet basement or near a swimming pool, etc.
- 6. Clean only with a damp cloth.** The appliance should be cleaned only as recommended by the manufacturer.
- 7. Install in accordance with the manufacturers instructions. Do not block any of the ventilation openings.** For example, the appliance should not be situated on a bed, sofa, rug, or similar surface or placed in a built-in installation, such as a bookcase or cabinet that may impede the flow of air through the ventilation openings.
- 8. Do not install near any heat sources** such as radiators, heat registers, stoves, or other apparatus (including amplifiers) that produce heat.

- 9. Do not defeat the safety purpose** of the polarized or grounding-type plug. A polarized plug has two blades with one wider than the other. A grounding type plug has two blades and a third grounding prong. The wide blade or the third prong are provided for your safety. When the provided plug does not fit into your outlet, consult an electrician for replacement of the obsolete outlet.

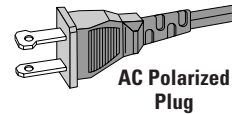

- 10. Protect the power cord** from being walked on or pinched particularly at plugs, convenience receptacles, and the point where they exit from the apparatus.

- 11. Only use attachments/accessories** specified by the manufacturer.

- 12. Use only with a cart,** stand, tripod, bracket, or table specified by the manufacturer, or sold with the apparatus. When a cart is used, use caution when moving the cart/apparatus combination to avoid injury from tip-over.



- 13. Unplug this apparatus** during lightning storms or when unused for long periods of time.

- 14. Refer all servicing** to qualified service personnel. Servicing is required when the apparatus has been damaged in any way, such as power-supply cord or plug is damaged, liquid has been spilled or objects have fallen into the apparatus, the apparatus has been exposed to rain or moisture, does not operate normally, or has been dropped.

EL 4562-E004: 99/3

Safety instructions	
Safety instructions	2 & 4
General information	
Scope of supply	5
Maintenance	5
Setup	5
Environmental information	5
Trademark acknowledgement	5
Controls	6
Remote control	
Remote control use	7
Remote control buttons	8
Programming the universal remote control	9
Connectors	10
Connections	
Audio connections	11
Digital audio connections	11
System control bus, CINEMA LINK	12
Video connections	12
Power	13
Speaker connections	13
TV as the center speaker	13
Antenna connections	13
System setup	
Positioning the speakers	14
Speaker setup and testing	14
Power handling	14
Headphones	14
Subwoofer (MX 975D only)	
Controls	15
Connectors	15
Connections	15
Adjustment	15
Operation	15
Display	16
Menus	
Receiver menu	17
TV menu	18
Source selection	
SOURCE SELECTOR	19
Reassigning a source selection	19
Using one source selection for two or more appliances	19
Playback, recording	
Playing a source	20
Adjusting the sound	20
Recording from a source	20
Recording from the digital output	20
Surround sound	
About surround sound	21
Switching surround sound	21
Surround sound settings	21
Tuner	
Tuning to radio stations	22
Switching FM sensitivity	22
Storing radio stations	22
Tuning to stored radio stations	23
Resorting stored radio stations	23
Naming radio stations	23
Clearing station names	23
Technical data	
Receiver	24
Speakers (supplied with MX 975D only)	24
Troubleshooting	
Warning	25
Troubleshooting	25
Limited warranty	
Limited warranty	26

Scope of supply

This receiver is supplied including:

- an universal remote control
- 2 batteries for the remote control, size AA
- a system bus cable for the CINEMA LINK connection
- a loop antenna
- a wire antenna
- 5 loudspeakers including 5 speaker cables (MX 975D only)
- a subwoofer including a connection cable and a power cable (only with MX 975D)
- a quick installation card (MX 975D only)
- this instruction booklet

Maintenance

Clean the receiver with a soft, slightly dampened, lint-free cloth. Do not use any cleaning agents as they may have a corrosive effect.



Do not expose the receiver to humidity, rain, sand or excessive heat (caused by heating equipment or direct sunlight).

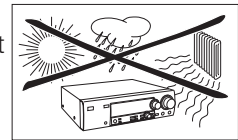

Setup

If you have stacked the components of your system, the receiver must be on top. Place the receiver on a flat, hard, stable surface. Do not cover any vents and leave 50 cm (20 inches) above and 10 cm (4 inches) to the left and right of the receiver clear for ventilation.

For good reception the loop antenna should not be placed on top of or beneath VCRs, CD recorders, DVD players, TVs and other radiation sources.

Environmental information

All redundant packing material has been omitted. We have tried to make the packaging easy to separate into three mono materials: cardboard (box), polystyrene foam (buffer) and polyethylene (bags, protective foam sheet).

Your set consists of materials which can be recycled if disassembled by a specialized company. Please observe the local regulations regarding the disposal of packing materials, dead batteries and old equipment.

Trademark acknowledgement

Manufactured under license from Dolby Laboratories. "DOLBY", "DOLBY DIGITAL", "PRO LOGIC" and the double-D symbol  are trademarks of Dolby Laboratories. Confidential unpublished works. © 1992–1997 Dolby Laboratories. All rights reserved.

CONTROLS

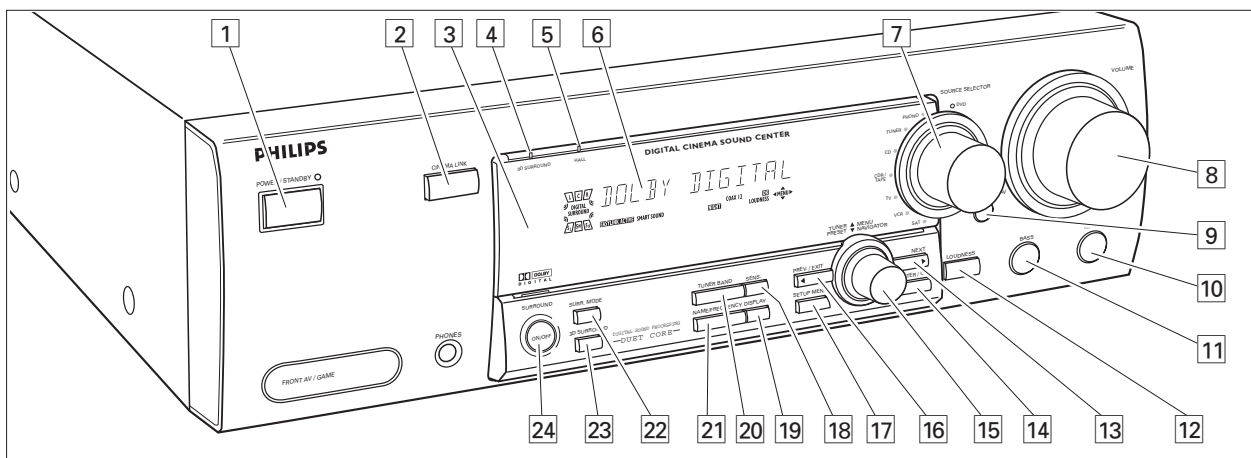

- | | |
|--|---|
| <p>1 POWER / STANDBY Switches the receiver on and off.</p> <p>2 CINEMA LINK Switches on and off the system control bus between the receiver and the TV.</p> <p>3 Sensor for the infrared remote control.</p> <p>4 3D SURROUND Control light for virtual 3D surround.</p> <p>5 HALL Control light for HALL.</p> <p>6 Display</p> <p>7 SOURCE SELECTOR Selects the different audio and video connectors.</p> <p>8 VOLUME Increases and decreases the volume level.</p> <p>9 FRONT AV Selects the FRONT AV / GAME input (MX 975D only).</p> <p>10 TREBLE Adjusts the treble when used in combination with VOLUME.</p> <p>11 BASS Adjusts the bass when used in combination with VOLUME.</p> <p>12 LOUDNESS Switches LOUDNESS on and off.</p> <p>13 NEXT ► TUNER: searches radio stations. MENU: switches to the next menu level.</p> | <p>14 ENTER / OK Confirms selected menu values.</p> <p>15 TUNER PRESET ◄ MENU NAVIGATOR
TUNER: switches to the next and previous stored radio station.
MENU: moves upwards and downwards.</p> <p>16 ◄ PREV. / EXIT
TUNER: searches radio stations.
MENU: switches to the previous menu level.</p> <p>17 SETUP MENU Switches the menu on and off.</p> <p>18 SENS. Switches between low and high tuner sensitivity.</p> <p>19 DISPLAY Switches the brightness of the display.</p> <p>20 TUNER BAND Switches the wavebands of the tuner.</p> <p>21 NAME/FREQUENCY Switches between name and frequency display.</p> <p>22 SURR. MODE Switches through the different surround effects.</p> <p>23 3D SURROUND Switches virtual 3D surround on and off.</p> <p>24 SURROUND ON/OFF Switches the surround sound on and off.</p> |
|--|---|

Remote control use

Open the battery compartment of the remote control and insert 2 alkaline batteries, type **AA** (R06, UM-3).

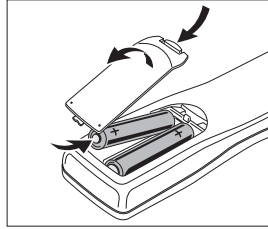

Remove batteries if they are dead or if the remote control will not be used for a long time.

Batteries contain chemical substances, so they should be disposed of properly.

The buttons on the remote control work the same way as the corresponding ones on the receiver.

Important!





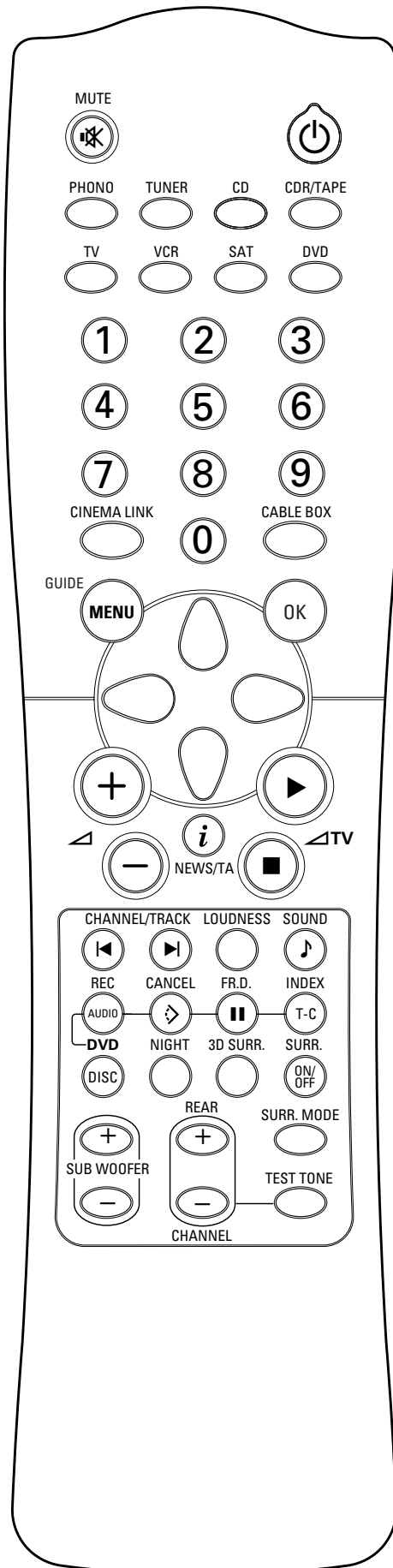









You have to press a source button for longer than 2 seconds to switch the sound source on the receiver. Pressing a source button for less than 2 seconds will only switch the remote control to use the commands for the selected product.

The remote control remains tuned to the selected source until another source button on the remote control is pressed. This enables you to operate additional sources (i. e. winding a tape) without changing the source on the receiver.



REMOTE CONTROL

Remote control buttons

 MUTE	Mutes the sound of the receiver.	REC, DVD AUDIO.....	CDR, VCR: Starts recording. DVD: Switches audio tracks.
	Switches the receiver to standby.	CANCEL, DVD 	CD, CDR, SAT, VCR: Clears a program, cancels selections. DVD: Switches the view angle.
PHONO, TUNER, CD, CDR/TAPE, TV, VCR, SAT, DVD.....	Switches the remote control to the commands of the different products. Selects the sources if pressed longer than 2 seconds. SAT only works with <i>digital</i> satellite receivers.	FR.D., DVD 	TUNER: Switches to FREQUENCY DIRECT. CD, CDR, VCR, DVD: Pauses playback.
1-0.....	Keys in numbers for tracks, stations or frequencies. Numbers consisting of two figures must be keyed in within 2 seconds.	INDEX, DVD T-C.....	VCR: Switches the index search on and off. SAT: Switches the themes on and off. DVD: Switches between title and chapter.
CINEMA LINK.....	Switches the system connection between the receiver and the TV on and off.	DISC.....	CD-, CDR-, DVD-Changers: Switches to the next disc.
CABLE BOX.....	(USA only) Switches the remote control to the cable box codes.	NIGHT.....	Switches NIGHT MODE on and off.
MENU GUIDE	TUNER: Switches the receiver menu on and off. DVD, TV: Switches the DVD/TV menu on and off.	3D SURR.....	Switches virtual 3D surround on and off.
OK.....	Confirms menu options.	SURR. ON/OFF.....	Switches SURROUND SOUND on and off.
Arrow buttons	TUNER: Moves in the menus. Right/left arrows are tuning up/down. CD, CDR: Left/right arrows are searching backwards/forwards, up/down arrows are selecting the next/previous track.	+ / - SUBWOOFER.....	Increases/decreases the subwoofer volume.
+ 	Increases the receiver volume.	+ / - REAR	Increases/decreases the volume of the rear speakers. While test tone is on, the volume of the speakers you are hearing can be increased/decreased with these buttons.
- 	Decreases the receiver volume.	SURR. MODE.....	Scrolls through the different surround modes.
 NEWS/TA.....	TUNER: Without function. TV: Switches teletext on and off. SAT: Switches the information text on and off.	TEST TONE	Switches the test tone on and off. While test tone is on, the volume of the speakers you are hearing can be increased/decreased with + / - REAR.
  TV	Increases the TV volume.		
  TV	Decreases the TV volume.		
 CHANNEL/TRACK	Selects the previous preset tuner station. VCR: Rewinds the tape. CD, CDR, DVD: Selects the previous track. TV: Selects the previous channel.		
 CHANNEL/TRACK	Selects the next preset tuner station. VCR: Fast forwards the tape. CD, CDR, DVD: Selects the next track. TV: Selects the next channel.		
LOUDNESS	Switches LOUDNESS on and off.		
 SOUND.....	Scrolls through the different smart sounds.		

Programming the universal remote control

You can identify the universal remote control by the inscription **Multibrand/Universal**.

The universal remote control must be programmed to use the codes for your appliances of different brands. This is done by keying in a 4-digit code or by scanning the codes until the correct one is found. We recommend to using the 4-digit code. This method is faster and more reliable. The code scanning method should be used only if you cannot find the code for one of your appliances. The codes are listed at the end of this book.

Important!



Use the remote control buttons for programming, not the buttons of the receiver or other appliances.

Programming with the 4-digit code

- 1 Keep the source button for the appliance which should be controlled and  pressed for 3 seconds.
- 2 Key in the 4-digit code for the appliance (codetable at the end of the booklet).

*Notes: – If more than 4 digits are entered, the remote control will recognize only the ones keyed in first.
 – If you do not key in a code within 30 seconds the remote control will switch off the programming function without changing the code.
 – To program a new appliance, simply overwrite the old code by entering a new one.*

Scanning the codetable

- 1 Switch on the appliance which should be controlled.
 - 2 Keep the source button for the appliance which should be controlled and  pressed for 3 seconds.
 - 3 Press and release  again.
 - The remote control sends the codes for channel up or standby (depending on the selected source) for one brand after the other.
 - 4 As soon as the appliance reacts – switches to the next channel or to standby – press  to confirm the code.
 - The identified code will be used.
- If the set does not react within 2 minutes, the code for this appliance is not stored in the remote control. The code of the remote control will remain unchanged.

Note: When taking out the batteries of the remote control for more than 1 minute the codes must be reprogrammed.

Once you have found and tested the codes for your various appliances, you may want to write them down here.

PHONO
TUNER.....
CD
CDR/TAPE
TV
VCR
SAT
DVD
CABLE BOX

Resetting the remote control

- 1 Keep one of the source buttons and  pressed for 3 seconds.
- 2 Key in the 3-digit code 981.
 - The remote control is now reset to all its original Philips codes.

CONNECTORS

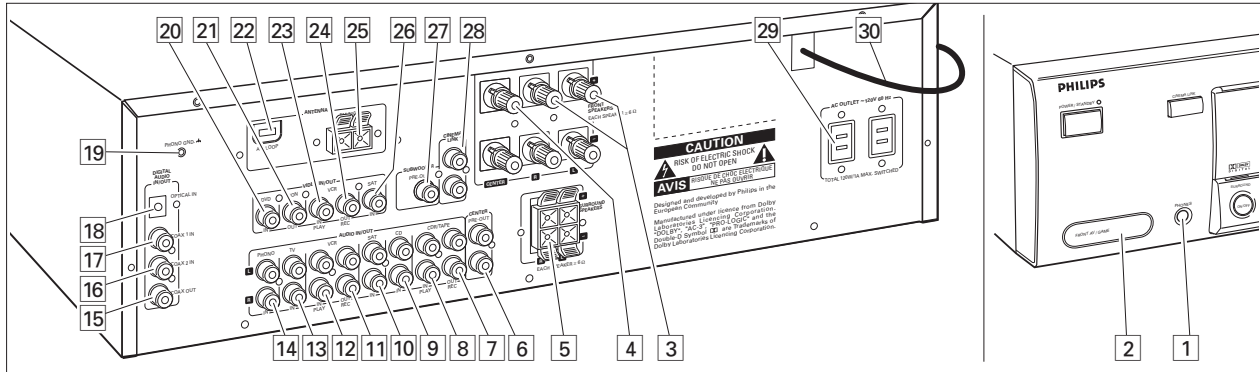

Connectors	Connectors name	Connect to:
6.3 mm headphone jack at the front.	1 PHONES	A headphone with a 6.3 mm plug.
Audio and video inputs at the front (MX 975D only).	2 FRONT AV / GAME	Audio and video out jacks of appliances such as video cameras and game consoles.
FRONT SPEAKERS	3 R, L	Right and left front speaker.
	4 CENTER	Center speaker.
SURROUND SPEAKERS	5 R, L	Right and left surround speaker.
AUDIO IN/OUT	7 CDR/TAPE OUT	Input of a CD recorder or a tape deck.
	8 CDR/TAPE IN	Output of a CD recorder or a tape deck.
	9 CD IN	Output of a CD player.
	10 SAT IN	Output of a satellite system.
	11 VCR OUT	Input of a video recorder.
	12 VCR IN	Output of a video recorder.
	13 TV IN	Output of a TV.
	14 PHONO IN	Output of a turntable with MM coil.
	19 PHONO GND 	Ground cable of a turntable.
DIGITAL AUDIO IN/OUT	15 COAX OUT	Coaxial input of digital appliances such as CD recorders or MD recorders.
	16 COAX 2 IN	Coaxial output of digital appliances.
	17 COAX 1 IN	Coaxial output of digital appliances.
	18 OPTICAL IN	Optical output of digital appliances such as DVD players, CD players, CD recorders or MD players.
VIDEO IN/OUT	20 DVD IN	Output of a DVD player.
	21 MON OUT	Input of a monitor (e. g. the TV).
	23 VCR IN	Output of a video recorder.
	24 VCR OUT	Input of a video recorder (for recording).
	26 SAT IN	Output of a satellite system.
Antenna connectors	22 AM LOOP	Frame antenna supplied.
	25 FM 300 Ω	Wire antenna supplied or exterior antenna.
Preamplified outputs	6 CENTER PRE-OUT	Input of a TV when it is used as the center speaker (only possible when the CINEMA LINK system bus is connected).
	27 SUBWOOFER PRE-OUT	Input of a powered subwoofer.
System control bus	28 CINEMA LINK	System control bus jacks of a Philips TV with CINEMA LINK.
Power outlets (not on all versions)	29 AC OUTLET	Supplies same voltage as mains. Up to 120 W/1A total permitted load.
Power cord	30	After all other connections have been made, connect the power cord to the wall outlet.

Audio connections

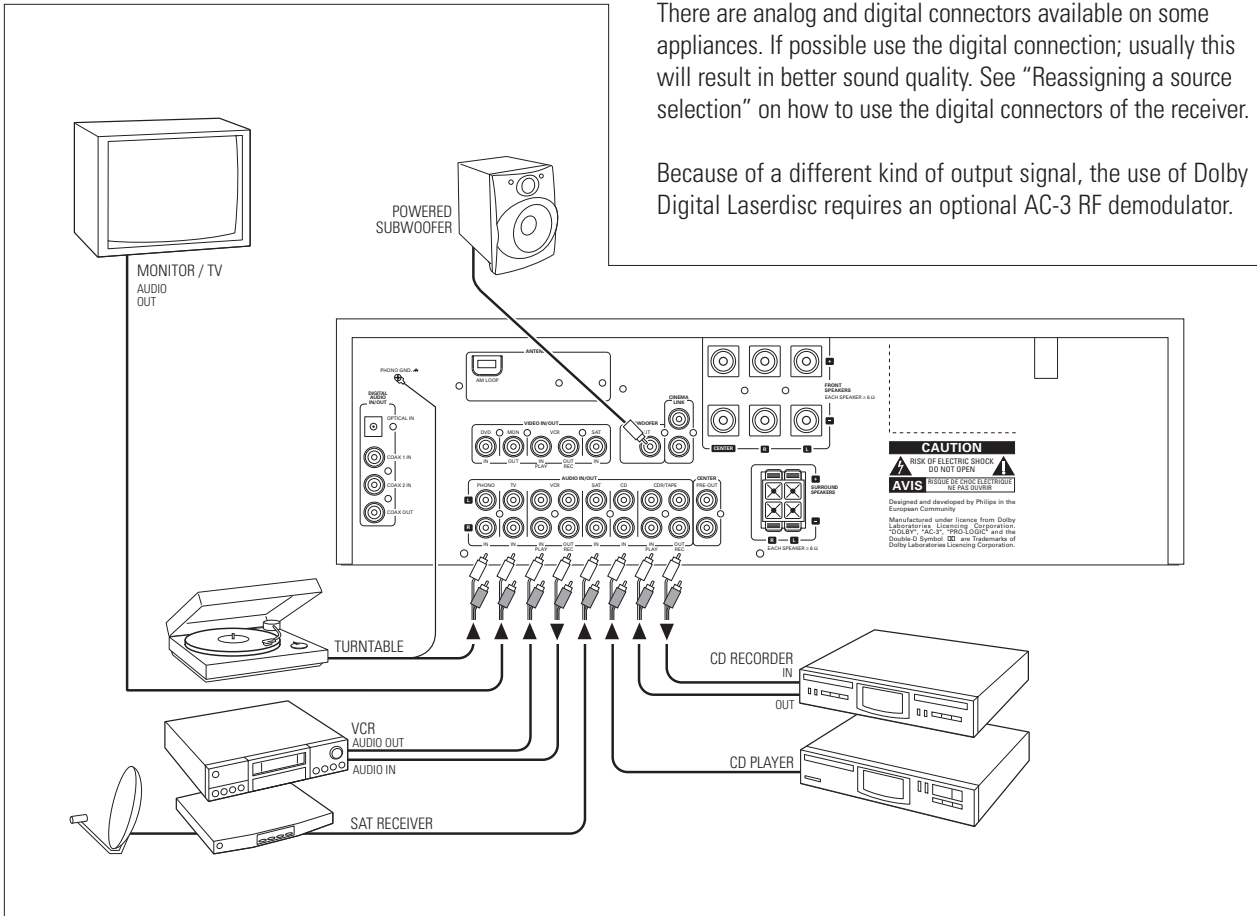

Digital audio connections

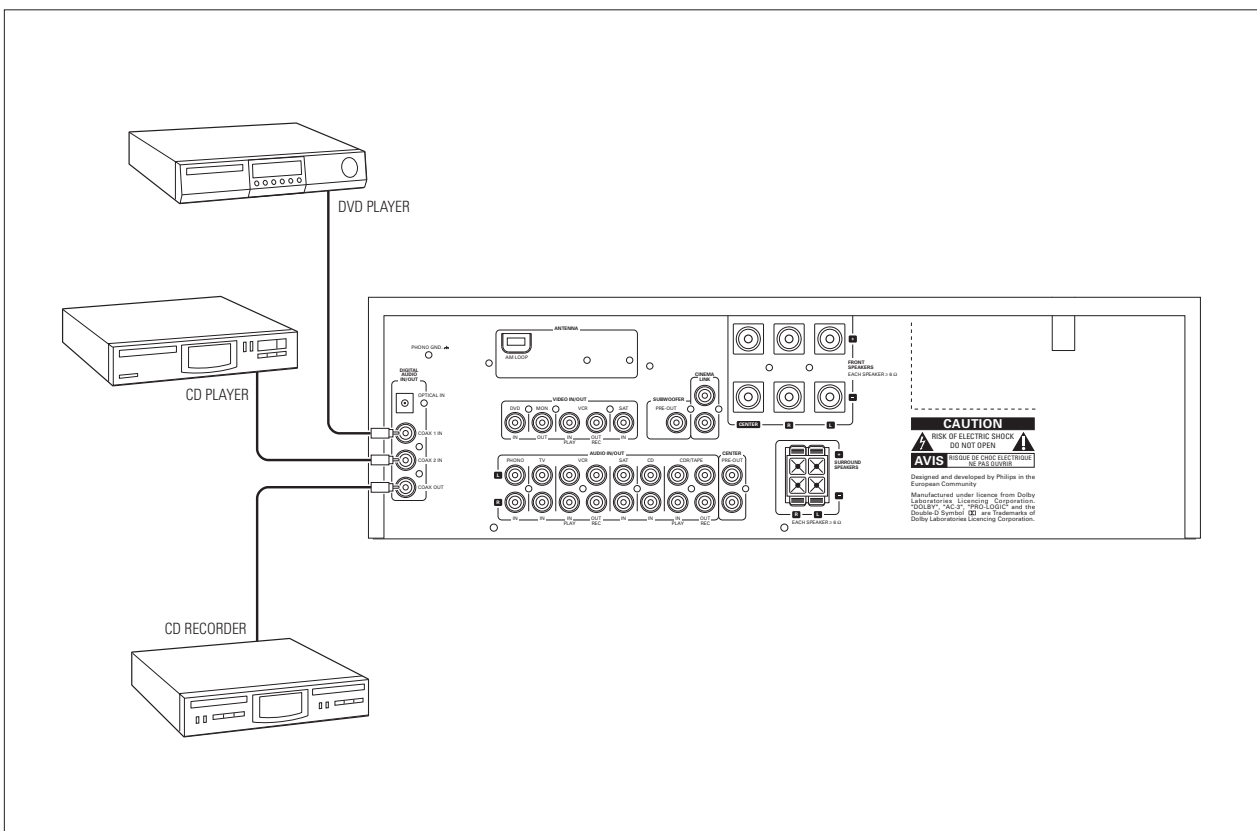

CONNECTIONS

System control bus, CINEMA LINK

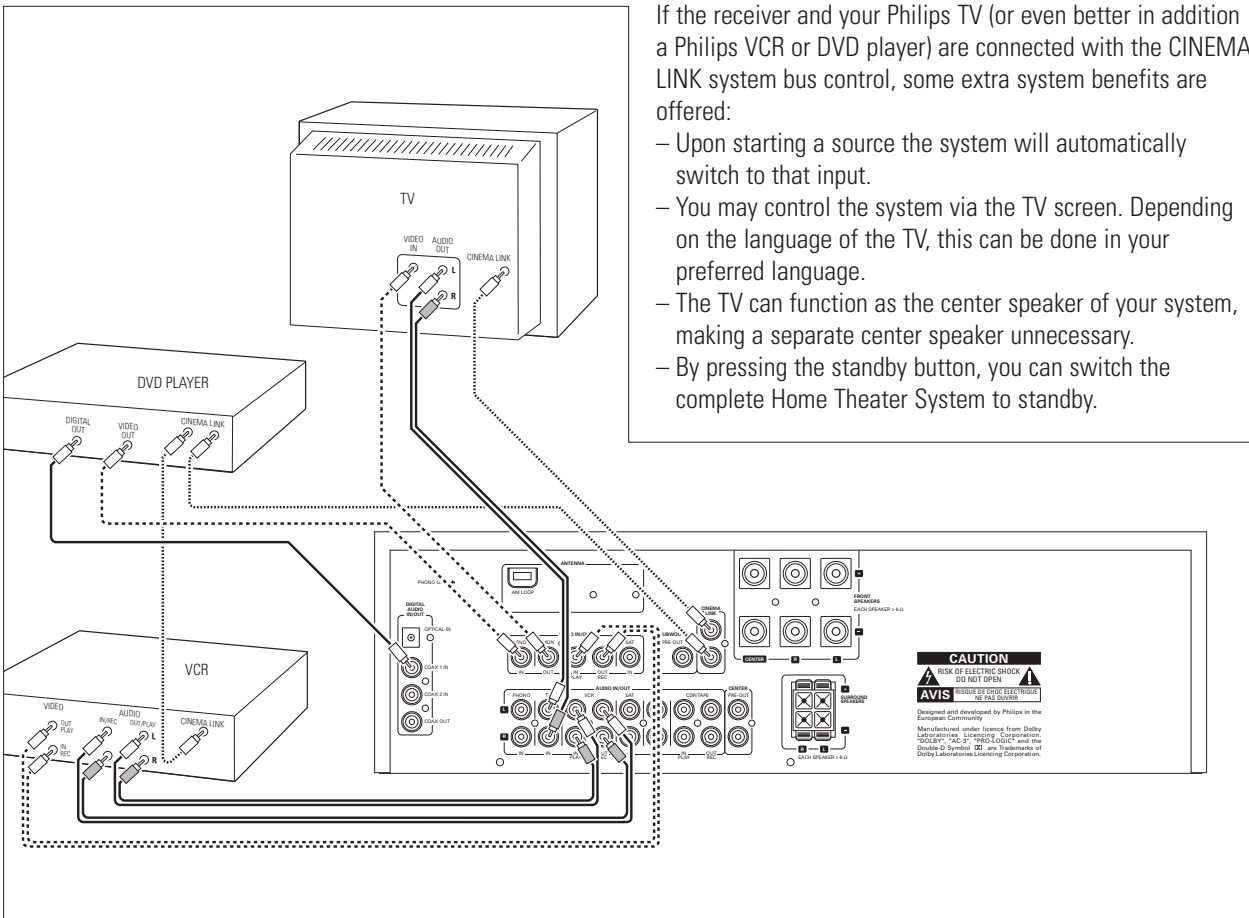

Video connections

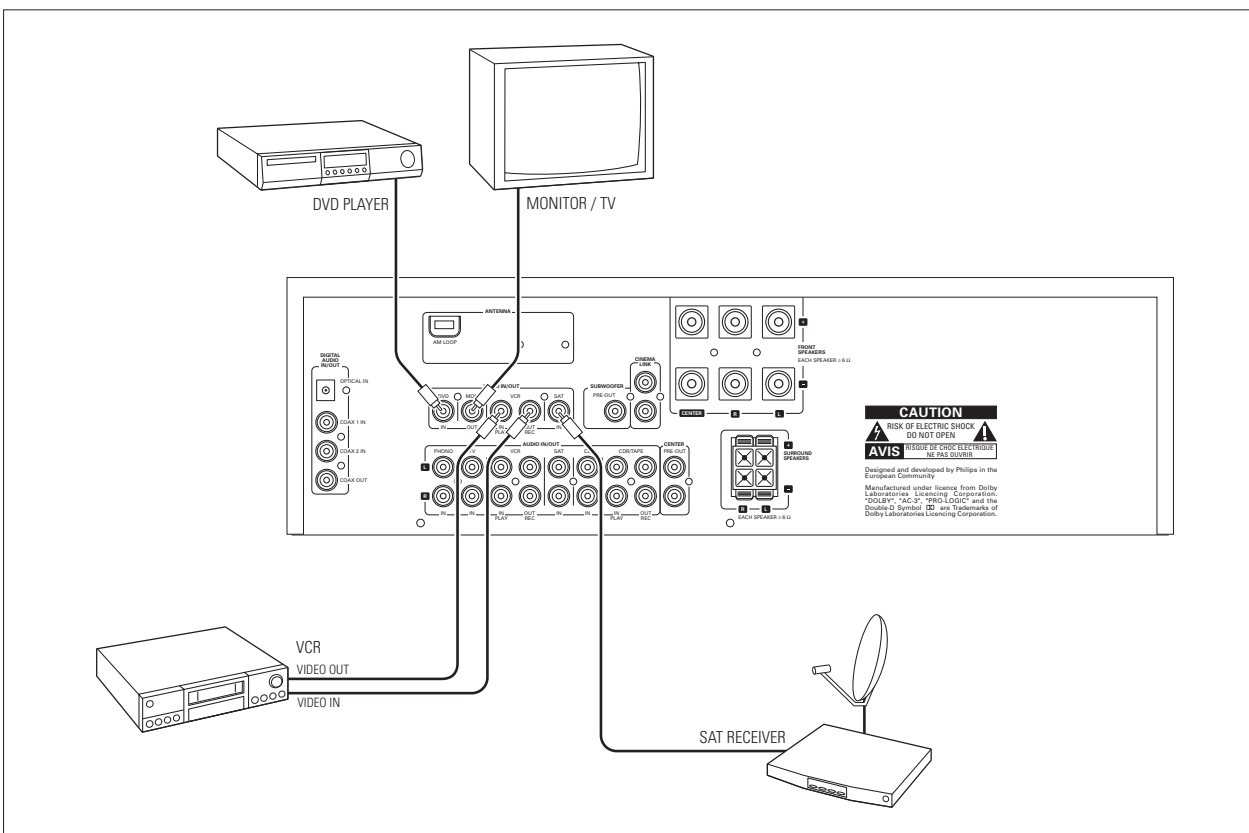

Power

The type plate is located on the rear of the receiver.

- 1 Check whether the power voltage as shown on the type plate corresponds to your local power voltage. If it does not, consult your dealer or service organization.
- 2 Connect the power cord to the power outlet.

To disconnect the unit from the power completely, remove the power plug from the power outlet.

Speaker connections

Some of the speaker connections on the receiver are screw connectors and some are click-fit connectors. Use them as shown below.

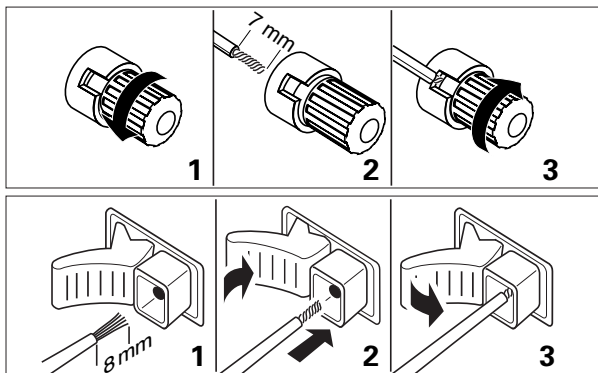

- 1 Always connect the colored (or marked) wire to the colored terminal and the black (or unmarked) wire to the black terminal.
- 2 Connect:
 - Left front speaker to L (red and black)
 - Right front speaker to R (red and black)
 - Center speaker to CENTER (blue and black)
 - Left surround speaker to SURROUND L (grey and black)
 - Right surround speaker to SURROUND R (grey and black)

TV as the center speaker

You may use your Philips TV with CINEMA LINK as the center speaker. For TVs with a scart connector an additional audio cinch-to-scart cable is needed. For TV's with cinch connectors, additional cinch cables are needed. These cables must be connected to the blue CENTER PRE-OUT connector on the back. Look into the instruction manual of your TV on how to use it as the center speaker.

Antenna connections

AM (MW) antenna

The loop antenna supplied is for indoor use only. Position the antenna as far away as possible from the receiver, a TV, the cables, a DVD player, a VCR and other radiation sources.

- 1 Fit the plug of the frame antenna to AM LOOP as shown below.
- 2 Turn the antenna for optimum reception.

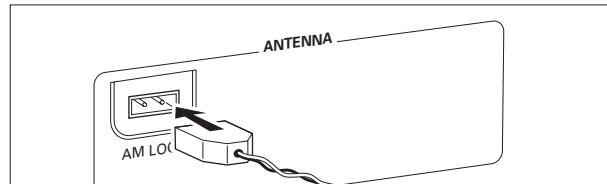

FM antenna

The wire antenna supplied can be used only to receive nearby stations. For better reception we recommend using a cable antenna system or an outdoor antenna.

- 1 Open the FM 300 Ω click-fits by pushing the lever down as shown below.
- 2 Insert each wire of the antenna into one hole.
- 3 Close the click-fits using the lever.
- 4 Move the antenna in different positions for optimum reception.

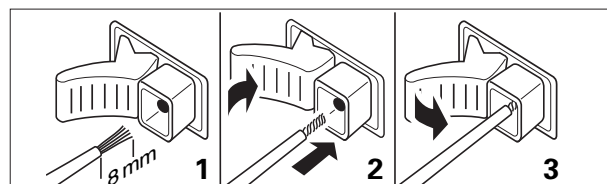

The unit complies with the FCC-Rules, Part 15.

Operation is subject to the following two conditions:

1. This device may not cause harmful interference, and
2. This device must accept any interference received, including interference that may cause undesired operation.

SYSTEM SETUP

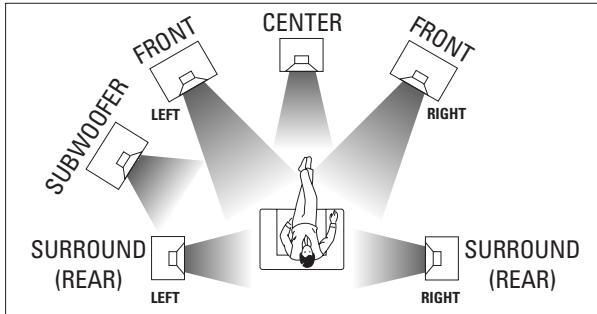

Positioning the speakers

General hints for positioning

Avoid positioning the speakers in a corner or on the floor as this will boost the bass tones too much. Placing the speakers behind curtains, furniture, etc. will reduce the treble response. The listener should always be able to "see" the speakers.

Each room has different acoustic characteristics and the positioning possibilities often are limited. You can find the best position for your speakers by referring to the picture above.

As a minimum we recommend 5 speakers (2 front, a center, 2 surround) for good surround sound. It is possible to reproduce some kind of surround sound with fewer speakers. This is done by redirecting the signals which are foreseen for the missing speakers to the existing ones. See "Menus" on how to set up the receiver correctly for the number and size of the speakers used.

Positioning the front speakers

The front speakers should be placed to the right and left in front of the listening position like usual stereo speakers.

Positioning the center speaker

The center speaker should be placed in the center between the two front speakers, e. g. underneath or on top of the TV. The best height for the center speaker is the height of the listener's ears (while seated).

Positioning the surround speakers

The surround speakers should face each other and be in line with, or slightly behind the listener.

Positioning the subwoofer

A subwoofer can be used to enhance the bass performance of your system dramatically. The subwoofer can be positioned anywhere in the room, because it is not possible to locate the source of deep tones. Nevertheless, you should not place the subwoofer in the middle of a room, since the bass could be severely weakened. Do not place any object on the subwoofer.

Speaker setup and testing

The relative volume of the speakers must be adjusted for optimal surround sound. You should be at your usual listening position when adjusting the speaker volume. See "Receiver menus" on how to unit up the receiver for the used speakers.

- 1 Press POWER / STANDBY to switch on the receiver.
- 2 Press TEST TONE on the remote control.
→ A test tone coming from the different speakers, except the subwoofer, is heard.
- 3 Press + / - REAR on the remote control to increase/decrease the volume of the actual speaker. The best result is achieved when all speakers have equal volume in the listening position.
- 4 Press TEST TONE on the remote control.
→ The test tone stops.

Note: If you are not completely satisfied with the volume settings, we recommend making minor adjustments to them during surround sound playback.

Power handling

If the receiver is used at very high power it can produce distortions which may damage your speakers seriously. If distortions occur, reduce the volume and the tone controls to a level where the sound is acceptable again.

To avoid overheating of the unit a safety circuit has been built in. Therefore your set may disconnect under extreme conditions. If this happens, switch the unit off and let it cool down before reusing it.

Headphones

Connecting headphones to PHONES will switch off the speakers. The receiver switches to STEREO and surround sound will be reduced to a stereo signal which is reproducible by standard headphones.

Disconnecting the headphones switches on the speakers again. If you wish to enjoy surround sound again, switch the receiver back to surround sound.

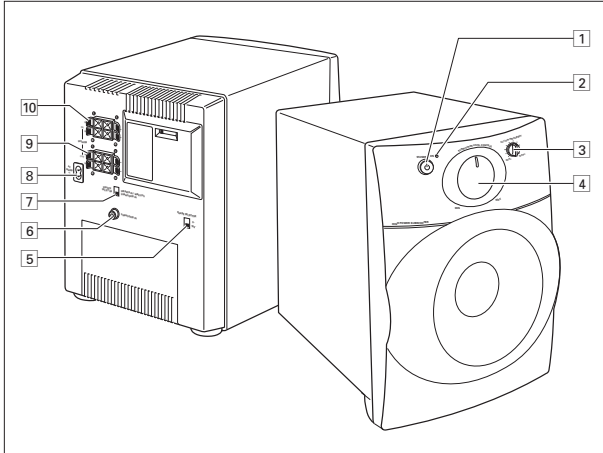

Controls

- 1 **STANDBY-ON**Switches the subwoofer on and to standby.
- 2Status light.
- 3 **CUT OFF FREQUENCY**.....Adjusts the frequency range reproduced by the subwoofer.
- 4 **SUBWOOFER LEVEL CONTROL**
Adjusts the volume of the subwoofer.

Connectors

- 5 **PHASE SELECTOR**.....Selects the best bass reproduction.
- 6 **SUBWOOFER IN**Connect to SUBWOOFER PRE-OUT at the receiver.
- 7 **SOURCE SELECTOR**Selects the used signal input. Keep at the SUBWOOFER IN position if the receiver is connected as described below.
- 8 **AC MAINS****After all other connections have been made**, connect the power cord to AC MAINS and to the power outlet.
- 9 **SPEAKER OUT**Not used with the receiver supplied.
- 10 **SPEAKER IN**Not used with the receiver supplied.

The type plate is located on the rear of the subwoofer.

Connections

- 1 Use the cinch cable supplied to connect SUBWOOFER IN to SUBWOOFER PRE-OUT at the receiver.
- 2 Check whether the power voltage as shown on the type plate corresponds to your local power voltage. If it does not, consult your dealer or service organization.
- 3 Connect the power cable to the power outlet. This switches on the power supply. Do not connect the subwoofer to the outlets of the receiver.

Note: To disconnect completely the subwoofer from the power, remove the power plug from the power outlet.

Adjustment

The subwoofer must be adjusted to your listening environment and to your speaker setup. This only needs to be done once.

- 1 Press to switch on the subwoofer.
→The status light turns green.
- 2 Play one of your favorite tracks at a normal listening level.
- 3 Turn SUBWOOFER LEVEL CONTROL to adjust the volume of the subwoofer.
- 4 Select the reproduced frequency range by turning CUT OFF FREQUENCY. The higher the cut off frequency is set, the stronger the bass reproduction will be.

Note: The subwoofer reproduces the range between 35 Hz and the frequency selected with CUT OFF FREQUENCY.

- 5 You may switch PHASE SELECTOR from 0° to 180°. Select the setting that provides the sound that produces the bass effect.
- 6 Press to switch the subwoofer to standby.
→The status light turns red.

Operation

- 1 Press to switch on the subwoofer.
→The status light turns green.
- 2 If the sound reproduction is noisy, reduce the volume of the subwoofer.
- 3 Press to switch the subwoofer to standby.
→The status light turns red.

Display

The display of the receiver is divided into 4 sections, which are to be used for the following:

Speaker diagram

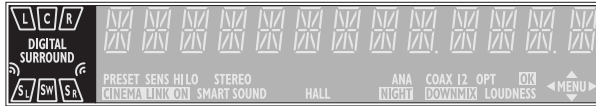

A rectangle with a letter in it shows that a speaker has been selected in the setup menu. However, the subwoofer indicator will only light when a subwoofer signal is available. If only a letter is shown, this speaker is not used and its sound is being reproduced by the other speakers.

-virtual 3D surround
- SURROUND**surround sound is reproduced
- DIGITAL SURROUND**digital surround sound is reproduced
- L, R**front left and right speaker
- C**center speaker
- SL, SR**surround speakers
- SW**subwoofer

Menu indication

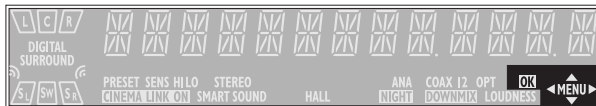

These signs show you if the menu is on or off and indicate in which direction you may move.

- MENU**Menu is on.
-You may move backwards to the previous menu topic using **PREV. / EXIT** ("left" key on the remote control).
-You may move up in an option list using **MENU NAVIGATOR** ("up" key on the remote control).
-You may move down in an option list using **MENU NAVIGATOR** ("down" key on the remote control).
-You may move forward to the next menu topic using **NEXT** ("right" key on the remote control).
-You may confirm the displayed value.

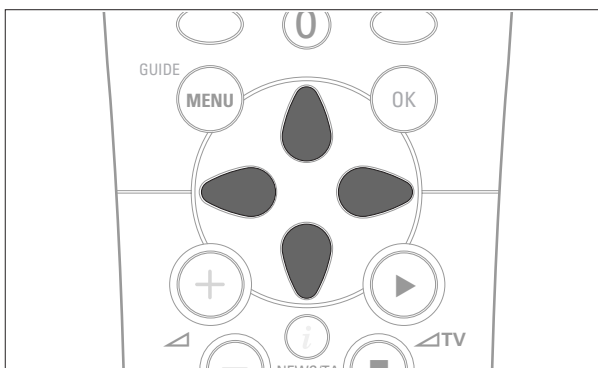

Status lights



Signs showing you various settings and information about the status of the receiver.

- PRESET**Tuner is tuned to a preset radio station.
- SENS HI**Tuner is switched to high sensitivity.
- SENS LO**Tuner is switched to low sensitivity.
- CINEMA LINK ON**CINEMA LINK is active
- STEREO**An FM station is being received in stereo.
- SMART SOUND**One of the preset sound settings of the receiver is being used.
- HALL**HALL effect is on.
- ANA**Analog input is being used for the playing source.
- NIGHT**NIGHT MODE is on.
- COAX 1**Coaxial digital input COAX 1 is being used for the playing source.
- COAX 2**Coaxial digital input COAX 2 is being used for the playing source.
- DOWNMIX**Incoming multichannel signals are being reduced to fewer output signals (depending on the number of speakers).
- OPT**Optical digital input OPTICAL IN is being used for the playing source.
- LOUDNESS**LOUDNESS is switched on.

Information area



This area is used for feedback of the receiver, tuner frequencies, menu options, values and scrolling text messages.

Receiver menu

The receiver is equipped with a menu system. The menu is used for the setup of the receiver. The different menu options are related to each other in a logical way. Let's assume you have no center speaker connected, and so you switched *CENTER SPEAKR* to *NO*. If you try to use *VOL CENTER*, a message will be scrolled that this is not possible (*INSTALL CENTER SPEAKER*).

The menu always works the same way. Arrows in the display show you the possible moving directions.

- 1 Press **SETUP MENU**.
→ **MENU**, and * *EFFECTS* is displayed.
- **You can exit the menu at any time by pressing SETUP MENU.**
- 2 Turn **▲** *MENU NAVIGATOR* until the desired option (or a value) is displayed.
- 3 Press **NEXT ▶** to choose the displayed option (or **ENTER / OK** to confirm a value).
- You can leave any option (values remain unchanged) by pressing **◀ PREV. / EXIT**.

Menu structure

- * *EFFECTS*
 - Switches sound effects.
 - *3D SURR*
virtual 3D surround: 0...100 %
- * *VOL BALANCE*
 - Adjusts the relative volume balance between the connected speakers.
 - *TEST TONE*
Test tone: on/off
 - *VOL FRONT-L*
Volume front left speaker: -50...+50
 - *VOL FRONT-R*
Volume front right speaker: -50...+50
 - *VOL CENTER*
Volume center speaker: -50...+50
 - *VOL REAR-L*
Volume rear left speaker: -50...+50
 - *VOL REAR-R*
Volume rear right speaker: -50...+50
 - *VOL SUBWOOFER*
Volume subwoofer: -50...+50
- * *SPEAKR SETUP*
 - Selects the used speakers.
 - *SUBW PRESENT*
Subwoofer present: yes/no
 - *CENTER SPEAKR*
Center speaker present: yes/no
 - *REAR SPEAKER*
Rear speakers present: yes/no

- * *SPEAKR SIZES*
 - Chooses the speaker sizes of the used speakers, for optimal sound reproduction. *LARGE* indicates a speaker which can reproduce frequencies lower than 50 Hz. If *SUBW PRESENT* is set to *NO*, *FRONT SIZE* can only be set to *LARGE*. If *FRONT SIZE* is set to *SMALL*, *CENTER SIZE* can only be set to *SMALL* and consequently a subwoofer must be connected.
 - *SUBW PRESENT*
Subwoofer present: yes/no
 - *FRONT SIZE*
Left and right front speakers: small/large
 - *CENTER SIZE*
Center speaker: small/large
 - *REAR SIZE*
Rear speakers: small/large
- * *SPK DISTANCE*
 - Distance between the usual listening position and the speakers. This defines the delay time for the surround sound.
 - *DISTANCE L/R*
Distance to front speakers: 1...10 m (3...30 ft)
 - *DISTANCE CNTR*
Distance to center speaker: 1...10 m (3...30 ft)
 - *DISTANCE REAR*
Distance to rear speakers: 1...10 m (3...30 ft)
- * *SELECT INPUT*
 - Assigns the audio input connectors to the different source selections chosen with *SOURCE SELECTOR* (see "Source selection" for details).
 - *COAX 1*
Digital coaxial input 1, COAX 1 IN
 - *COAX 2*
Digital coaxial input 2, COAX 2 IN
 - *OPT*
Digital optical input, OPTICAL IN
 - *SAT IN*
Analog audio input SAT IN
 - *VCR IN*
Analog audio input VCR IN
 - *TV IN*
Analog audio input TV IN
 - *CDR IN*
Analog audio input CDR IN
 - *CD IN*
Analog audio input CD IN
- * *TUNER*
 - Setup for preset radio stations (see "TUNER" for details).
 - *AUTO INSTALL*
Stores radio stations automatically
 - *MAN INSTALL*
Stores radio stations manually
 - *GIVE NAME*
Allows you to assign names to stored radio stations
 - *RESHUFFLE*
Resorts stored radio stations

TV menu

If the receiver is connected to a Philips CINEMA LINK TV via the CINEMA LINK system control bus jacks (see "CONNECTIONS"), you may use the TV to set up the system. An option called RECEIVER will be added to the TV menu.

If CINEMA LINK is on, adjustments on the receiver will be shown on the TV screen for a few seconds. Consult the instruction booklet of your TV on how to use the TV menu. The options offered may vary by TV model.

Switching the connection

- Press CINEMA LINK on or off to switch the connection between the receiver and the TV.
 - If the connection is switched on, **CINEMA LINK ON** is displayed.

Note: We recommend switching CINEMA LINK off during recording. This avoids unwanted interruptions due to switching TV functions.

If CINEMA LINK is switched on and the TV menu is active, TV MENU is displayed and the menu and sound functions on the receiver are locked.

SOURCE SELECTOR

When selecting a source by turning SOURCE SELECTOR, the audio and video inputs with the corresponding name are activated. The incoming signal is reproduced by all audio and – if the source includes a video signal – video outputs of the receiver. It is possible to reassign a source selection to other than these standard inputs.

Source selectedConnectors used

DVD.....	COAX 1 digital audio input and DVD IN video input
PHONO.....	PHONO IN audio input
TUNER.....	The tuner part of the receiver is used, all inputs are switched off.
CD.....	CD IN audio input
CDR/TAPE.....	CDR/TAPE IN audio input
TV.....	TV IN audio input and no video input
VCR.....	VCR IN audio input and VCR IN video input
SAT.....	SAT IN audio input and SAT IN video input

Reassigning a source selection

If a source is selected with SOURCE SELECTOR the standard audio input is used. To change this, the source selection must be reassigned to another audio input.

Example: Reassigning **CD** from the analog CD IN audio input to the digital COAX 2 IN audio input.

- 1 Choose * **SELECT INPUT** from the menu and press **NEXT ▶**.
- 2 Turn SOURCE SELECTOR to select the source which should be reassigned (e. g. **CD**).
→ The name of the source is displayed and the light of the source flashes.
- 3 Turn **◆** MENU NAVIGATOR to select the input connectors which should be used (e. g. **CD** → **COAX 2**).
- 4 Press ENTER / OK to confirm your selection.
→ **STORED** is displayed briefly.
- 5 This source selection is now using the chosen audio input (e. g. **CD** uses the COAX 2 IN input connectors, **COAX 2** lights when switching to CD).

Using one source selection for two or more appliances

You may assign more than one source to a source selection. This can be useful when products are connected one after the other in a chain.

Example: A VCR is connected to the TV but only the TV is connected to the receiver. Both SOURCE SELECTOR settings, TV as well as VCR, have to use the TV input connectors.

- 1 Choose * **SELECT INPUT** from the menu and press **NEXT ▶**.
- 2 Turn SOURCE SELECTOR to select the source which should be reassigned (e. g. **VCR**).
→ The name of the source is displayed and the light of the source flashes.
- 3 Turn **◆** MENU NAVIGATOR to select the input connectors which should be used (e. g. **VCR** → **TV IN**).
- 4 Press ENTER / OK to confirm your selection.
→ **STORED** is displayed briefly.
- 5 This source selection is now using the chosen audio input (e. g. **VCR** uses the TV IN input connectors, **VCR (TV IN)** is displayed briefly when switching to VCR).

Playing a source

- 1 Press POWER / STANDBY to switch on the receiver.
- 2 Turn SOURCE SELECTOR to select a source.
→ The name of the source is displayed.
- You can select the FRONT AV/GAME input by pressing FRONT AV (MX 975D only).
- 3 Start playback of the source as usual.

Adjusting the sound

- Turn VOLUME to adjust the volume.
→ VOLUME and the volume level between 0 and 50 is displayed.
- 1 Press BASS or TREBLE.
→ BASS or TREBLE and the actual value are displayed briefly. Then TURN VOLUME KNOB TO CHANGE is scrolled.
 - 2 Turn VOLUME to adjust the bass or treble.
→ BASS or TREBLE and the actual value are displayed.

Note : If VOLUME is not turned within 5 seconds or if any other control is used, the bass or treble adjustment is switched off.

- Press  SOUND on the remote control to scroll through the built-in smart sounds: MOVIE, SPEECH, MUSIC, MULTIMEDIA and PERSONAL. (PERSONAL is the userdefined bass and treble setting.)
→ SMART SOUND is displayed and the name of the chosen sound profile is scrolled once if smart sound is on.
- Press LOUDNESS to switch on or off loudness.
→ LOUDNESS is displayed if loudness is on.

Recording from a source

If you wish to record from a source you must select it with SOURCE SELECTOR. The incoming signal is reproduced by all audio and – if the source includes a video signal – video outputs of the receiver. The sound settings do not affect the recording.

- 1 Turn SOURCE SELECTOR (or press FRONT AV – MX 975D only) to select the source you want to record from.
→ The name of the source is displayed.
- 2 Prepare the desired recording appliance. It must be connected to one of the outputs of the receiver.
- 3 Start recording on the recording appliance.
- 4 Start the playback of the source as usual.

*Note: – The audio and video signal of VCR IN is not reproduced by VCR OUT. The same applies to the audio signal of CDR/TAPE IN to CDR/TAPE OUT.
– We recommend not to use the digital output COAX OUT of the receiver to record from an analog source. Use the analog output CDR/TAPE instead.*



Recording from the digital output

It is possible to connect a digital recorder to the digital output of the receiver. In this way, all signals coming from the digital inputs can be recorded directly on the connected audio recorder. The receiver will also convert all signals coming from the analogue inputs to the digital output.

The receiver can be used to record digitally a multichannel surround sound audio signal (Dolby Digital) from, for example, DVD to CD-R. The receiver will convert the digital multichannel signal into a stereo signal without loss of relevant sound information.

*Notes: – Do not use the 3D SURROUND feature while making digital recordings as this will distort the digital audio signal.
– When recording a Dolby Digital signal, each track must be recorded individually.*

About surround sound

Surround sound gives you a completely new listening sensation. You will have the feeling of being in the middle of the action, because sound is coming from everywhere around you. Look out for TV broadcasts, audio and video tapes and discs with the  or  or marks which are encoded for multichannel surround sound. You should prefer Dolby Digital to get the most out of your receiver.

Notice that DVDs do not always carry full multichannel surround. To be sure that a disc is multichannel encoded consult your dealer.

Most ordinary stereo tapes and discs can be replayed using surround sound settings with good results. If the reproduction is distorted in surround mode, switch to normal stereo mode.

The availability of the various surround sound modes described depends on the number of speakers used and the incoming sound information.

Switching surround sound

With surround sound on, you can switch through the different surround modes. Note that the possibilities are related to speaker setup defined in the receivers menu.

If a digital surround signal is detected, the receiver will scroll *DOLBY DIGITAL*.

- 1 Press SURROUND ON/OFF to switch on the surround sound.
 - The surround mode in use is scrolled.
- 2 Press SURR. MODE repeatedly to listen to the different surround modes (if available).
 - The chosen mode and the speakers used are displayed. If the incoming multichannel signals are reduced to fewer output signals, **DOWNMIX** is displayed.
- 3 Press 3D SURROUND to switch on or off virtual 3D surround.
 - A light indicates if virtual 3D surround is on.
- 4 Press SURROUND ON/OFF to switch off the surround sound.
 - *SURROUND OFF* is scrolled.

Surround sound settings

HALL

The sound reproduction is enhanced and a slight echo is added. This gives the impression of being in a large room. Can only be used in stereo mode.

SURROUND

The surround mode enables normal surround sound reproduction with 4 or 5 speakers. Depending on the source material, Dolby Surround Pro Logic or Dolby Digital is reproduced.

PRO LOGIC, DOLBY DIGITAL

In addition to *SURROUND*, the surround mode used – depending on the source material – will be displayed. In case of digital surround, the sound format AC-3 (for Dolby Digital) will be displayed, followed by the sound channels, available on the source (e. g. DVD).

Example: *AC-3 3/2.1* Dolby Digital, 3 front channels, 2 surround channels and a subwoofer channel.

AC-3 3/1.0 Dolby Digital, 3 front channels, 1 (mono) surround channel without subwoofer signal.

FRONT-3 STEREO

The surround sound is muted. 3 Stereo lets you listen to surround sound without using the surround speakers.

3D SURROUND

The sound of the rear channel is simulated by the front speakers. Surround sound is simulated through the front left, right and center speakers. The position of the listener influences the surround effect. The area where the effect is best is shown in gray.

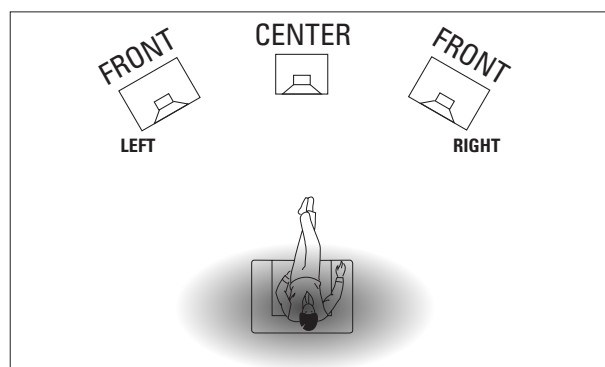

STEREO

All sound is reproduced and played through the front left and right speakers. This enables standard stereo reproduction.

NIGHT MODE (only on the remote control)

The loud parts of the sound are lowered and the soft passages are raised. You can enjoy surround sound without disturbing sleeping children or neighbors. Night mode only works with Dolby Digital, and only if supported by the source material.

Tuning to radio stations

You can search for radio stations by scanning the frequency band. You can also key in the frequency of a known radio station. If an FM station is being broadcast and received in stereo, **STEREO** is shown.

Searching for radio stations

- 1 Turn SOURCE SELECTOR to select the tuner.
→ **TUNER** is displayed.
 - 2 Select a waveband by pressing TUNER BAND repeatedly.
→ The selected waveband is displayed.
 - 3 Keep ◀ or ▶ pressed for approximately 1 second.
→ **SEARCH** is displayed and the tuner tunes to a station with sufficient strength.
 - 4 Repeat this procedure until you find the desired station.
- To fine tune to a weak transmitter, briefly press ◀ or ▶ as often as necessary for optimum reception.

Tuning to a radio station by frequency (with the remote control only)

- 1 Press TUNER.
→ **TUNER** is displayed.
- 2 Press FR. D..
→ **_** is displayed.
- 3 Use 1–0 to key in the frequency of a radio station.

Notes: Only valid numbers within the frequency range of the tuner can be keyed in.

Switching FM sensitivity

You can switch the tuner to a lower search sensitivity, to search only for stations with a strong signal (FM only).

- 1 Turn SOURCE SELECTOR to select the tuner.
→ **TUNER** is displayed.
- 2 Press SENS. on the receiver.
→ Either **SENS HI** or **SENS LO** is displayed for 5 seconds.

*Note: While searching for radio stations, the actual sensitivity is displayed. In this case, **SENS LO** means the tuner is looking only for radio stations with a strong signal.*

Storing radio stations

You may store up to 30 radio stations in the memory. The receiver can select and program radio stations by itself or you can choose them yourself.

Automatic programming

- 1 Choose * **TUNER** from the menu and press NEXT ▶.
- 2 Choose **AUTO INSTALL** and press NEXT ▶.
→ The preset number where programming will start, the waveband and **AUTO** are displayed.
- 3 Turn TUNER PRESET ⬇ to change the preset number where programming should start.
- 4 Use TUNER BAND to switch to the desired waveband.
- 5 Press ENTER / OK to start programming.
→ **AUTO INSTALL** flashes and all available radio stations are programmed, this may take a few minutes. Programming is done when **AUTO INSTALL** stops flashing.

Manual programming

- 1 Choose * **TUNER** from the menu and press NEXT ▶.
- 2 Choose **MAN INSTALL** and press NEXT ▶.
→ A preset number, the waveband and the frequency are displayed.
- 3 Turn TUNER PRESET ⬇ to change to the preset number where the radio station should be stored.
- 4 Tune to the desired radio station (see "Searching for radio stations").
- 5 Press ENTER / OK to confirm your selection.
→ **STORE** is displayed briefly. The radio station is programmed at the chosen preset number.
- 6 Select and store all desired radio stations this way.

Tuning to stored radio stations

- 1 Turn SOURCE SELECTOR to TUNER to select the tuner.
→ TUNER is displayed.
- 2 Turn TUNER PRESET \blacklozenge to select a preset radio station.
→ PRESET, the preset number and station are displayed.

Resorting stored radio stations

After programming radio stations, you might want to change their sequence. *RESHUFFLE* allows you to exchange the positions of presets.

- 1 Choose * TUNER from the menu and press NEXT \blacktriangleright .
- 2 Choose *RESHUFFLE* and press NEXT \blacktriangleright .
→ PRESET, a preset number and station are displayed.
- 3 Turn TUNER PRESET \blacklozenge to select a preset station.
- 4 Press ENTER / OK to confirm the selection.
→ The selected preset number *SWAP* (↔) and a second preset number are displayed.
- 5 Turn TUNER PRESET \blacklozenge to select the other preset station.
- 6 Press ENTER / OK to confirm the exchange.
→ *RESHUFFLE* is displayed briefly and these two preset numbers are swapped.

Naming radio stations

It is possible to assign a name to any of the preset radio stations.

- 1 Choose * TUNER from the menu and press NEXT \blacktriangleright .
- 2 Choose *GIVE NAME* and press NEXT \blacktriangleright .
→ A preset radio station is displayed.
- 3 Turn TUNER PRESET \blacklozenge to select the preset to be renamed.
- 4 Press ENTER / OK to confirm your selection.
→ The existing name or _____ is displayed.
- 5 Turn TUNER PRESET \blacklozenge to select a letter and NEXT \blacktriangleright or \blacktriangleleft PREV. to move to the next or previous position.
- 6 After you have entered the entire name, press ENTER / OK to confirm.
→ *STORE* is displayed and the name is stored.

Clearing station names

- 1 Use the menu option * TUNER, choose *GIVE NAME*.
→ A preset radio station is displayed.
- 2 Turn \blacklozenge MENU NAVIGATOR to select the name to be cleared.
- 3 Press ENTER / OK to confirm your selection.
- 4 Press \blacktriangleleft PREV. while the first letter is flashing.
→ *CL* is flashing to the left of the station name.
- 5 Press ENTER / OK to clear the station name.
Or, if you have changed your mind,
press \blacktriangleleft PREV. to leave the station name as it is.

Receiver

Subject to modification without notice.

General

Power consumption (FR 960).....	≈ 175 W
Power consumption (FR 970).....	≈ 195 W
Standby power consumption.....	< 2 W
Dimensions, w × h × d.....	435 × 135 × 350 mm
Weight (FR 960).....	8.6 kg
Weight (FR 970).....	9.4 kg

Amplifier part (0.7 % THD, 6 Ω, 1 kHz)

Output power, stereo mode (FR 960, 40 Hz–20 kHz).....	2 × 50 W
Output power, surround mode (FR 960)	
Front.....	2 × 60 W
Center.....	60 W
Surround.....	2 × 60 W
Output power, stereo mode (FR 970).....	2 × 100 W
Output power, surround mode (FR 970)	
Front.....	2 × 100 W
Center.....	100 W
Surround.....	2 × 50 W
Bass.....	±9 dB at 100 Hz
Treble.....	±9 dB at 10 kHz
Loudness.....	+6 dB at 100 Hz (-30 dB); +3 dB at 10 kHz (-30 dB)
Total harmonic distortion.....	0.05 % at 1 kHz, 1 W
Frequency response.....	20–30,000 Hz, ±1 dB
S/N ratio.....	≥ 82 dB
Stereo separation (1 kHz).....	≥ 45 dB
Crosstalk (1 kHz).....	≤ -65 dB

Inputs

Linear inputs.....	250 mV at 47 kΩ
Front AV (FR 970, MX 975D only).....	250 mV at 22 kΩ
Phono.....	5 mV at 47 kΩ
Digital coaxial.....	75 Ω acc. IEC 958

Outputs

Power supply AC outlets (switched).....	totally max. 120 W
Linear outputs.....	250 mV at 1 kΩ
Digital coaxial.....	75 Ω acc. IEC 958
Digital optical.....	toslink
Subwoofer pre-out.....	0.8 V at 1 kΩ
Center pre-out.....	0.8 V at 1 kΩ
Headphones.....	8–600 Ω (3 V e.m.f., 60 Ω)
Speakers.....	≥ 6 Ω

Tuner part

Wave range	
FM.....	87.5–108.0 MHz
AM.....	530–1,700 kHz
Sensitivity	
Stereo FM.....	41 dBf
Mono FM.....	17 dBf
Total harmonic distortion	
Stereo FM.....	0.8 %
Mono FM.....	0.9 %
Frequency response.....	63–12,500 Hz ±1 dB

S/N ratio

Stereo FM.....	55 dB
Mono FM.....	60 dB
Channel separation.....	27 dB at 1 kHz

Speakers (supplied with MX 975D only)

Subject to modification without notice.

Front speakers

Impedance.....	6 Ω
Frequency range.....	40–20,000 Hz
Power handling capacity.....	100 W
Power handling capacity – peak.....	150 W
Sensitivity.....	89 dB
Drivers.....	1 × 5¼" woofer, 1 × 2" tweeter
Passive radiator.....	1 × 6½" woofer
Crossover frequencies.....	4,000 Hz
Dimensions, h × w × d.....	421 × 219 × 191 mm
Weight.....	approx. 2.5 kg

Rear speakers

Impedance.....	6 Ω
Frequency range.....	40–20,000 Hz
Power handling capacity.....	50 W
Power handling capacity – peak.....	100 W
Sensitivity.....	89 dB
Drivers.....	1 × 5¼" woofer, 1 × 2" tweeter
Passive radiator.....	1 × 6½" woofer
Crossover frequencies.....	4,000 Hz
Dimensions, h × w × d.....	421 × 219 × 191 mm
Weight.....	approx. 2.5 kg

Center speaker

Impedance.....	6 Ω
Frequency range.....	75–20,000 Hz
Power handling capacity.....	100 W
Power handling capacity – peak.....	150 W
Sensitivity.....	89 dB
Drivers.....	2 × 4" woofers, 1 × 2" tweeter
Crossover frequencies.....	4,500 Hz
Dimensions, h × w × d.....	131 × 435 × 122 mm
Weight.....	approx. 1.6 kg

Powered subwoofer

Power consumption.....	30 W
Standby power consumption.....	< 4.5 W
Output power.....	50 W
Frequency range.....	35–140 Hz
Input sensitivity.....	200 mV at 22 kΩ
Sensitivity.....	89 dB
Drivers.....	1 × 5¼" cone type
Crossover cut-off frequencies.....	60–150 Hz
Dimensions, h × w × d.....	310 × 235 × 355 mm
Weight.....	approx. 7.1 kg

WARNING

Under no circumstances should you try to repair the set yourself as this will invalidate the warranty. Do not open the set as there is a risk of electric shock.

If a fault occurs, first check the points listed, before taking the set for repair.

If you are unable to solve a problem by following these hints, consult your dealer or service centre.

PROBLEM	POSSIBLE CAUSE	SOLUTION
No sound	VOLUME is not adjusted correctly.	Adjust the VOLUME.
	Headphones are connected.	Disconnect headphones.
	The wrong source is selected.	Turn SOURCE SELECTOR to select the correct source.
No sound on the left or right side	One speaker is connected incorrectly.	Connect the speaker properly.
	A speaker cable is damaged.	Replace the cable.
	Volume balance in the receiver menu is adjusted incorrectly.	Adjust <i>VOL FRONT-L</i> and <i>VOL FRONT-R</i> in the receiver menu.
Poor sound or no sound at the center or surround speakers	SURROUND mode is not switched on.	Press SURROUND ON/OFF to switch on the surround sound.
	Surround and/or center speakers are not (properly) connected.	Connect the speakers properly.
	Surround and/or center speakers are switched off in the <i>SPEAKER SETUP</i> menu.	Set speaker present to <i>YES</i> .
	A speaker cable is damaged.	Replace the cable.
Poor bass sound	Speakers are not in phase.	Connect the colored (or marked) wires to the colored terminals and the black (or unmarked) wires to the black terminals.
Bad sound	Badly matching setting for the given type of music or sound.	Correct the sound settings on the receiver.
Surround sound level is too low or too high	The level of the surround sound is not adjusted properly.	Adjust the level of the surround sound on the receiver.
Center sound level is too low or too high	The sound level of the center channel is not adjusted properly .	Adjust the level of the center channel on the receiver.
Only center speaker is heard in Dolby Surround Pro Logic	A mono signal is reproduced.	Choose a different sound source or switch off surround sound.
Bad radio reception, automatic programming does not work properly	Receiver or antenna is positioned near a radiation source such as TV, CD player, CD recorder, DVD player, etc.	Change the position of the interfering unit or try to switch it off.

LIMITED WARRANTY

AUDIO SYSTEM

One Year Free Labor

One Year Free Service on Parts

This product must be carried in for repair.

WHO IS COVERED?

You must have proof of purchase to receive warranty service. A sales receipt or other document showing that you purchased the product is considered proof of purchase.

WHAT IS COVERED?

Warranty coverage begins the day you buy your product. For one year thereafter, all parts will be repaired or replaced, and labor is free. After one year from the day of purchase, you pay for the replacement or repair of all parts, and for all labor charges. All parts, including repaired and replaced parts, are covered only for the original warranty period. When the warranty on the product expires, the warranty on all replaced and repaired parts also expires.

WHAT IS EXCLUDED?

Your warranty does not cover:

- labor charges for installation or setup of the product, adjustment of customer controls on the product, and installation or repair of antenna systems outside of the product.
- product repair and/or part replacement because of misuse, accident, unauthorized repair or other cause not within the control of Philips Consumer Electronics Company.
- reception problems caused by signal conditions or cable or antenna systems outside the unit.
- a product that requires modification or adaptation to enable it to operate in any country other than the country for which it was designed, manufactured, approved and/or authorized, or repair of products damaged by these modifications.
- incidental or consequential damages resulting from the product. (Some states do not allow the exclusion of incidental or consequential damages, so the above exclusion may not apply to you. This includes, but is not limited to, prerecorded material, whether copyrighted or not copyrighted.)
- a product that is used for commercial or institutional purposes.

WHERE IS SERVICE AVAILABLE?

Warranty service is available in all countries where the product is officially distributed by Philips Consumer Electronics Company. In countries where Philips Consumer Electronics Company does not distribute the product, the local Philips service organization will attempt to provide service (although there may be a delay if the appropriate spare parts and technical manual(s) are not readily available).

MAKE SURE YOU KEEP..

Please keep your sales receipt or other document showing proof of purchase. Attach it to this owner's manual and keep both nearby. Also keep the original box and packing material in case you need to return your product.

BEFORE REQUESTING SERVICE...

Please check your owner's manual before requesting service. Adjustments of the controls discussed there may save you a service call.

TO GET WARRANTY SERVICE IN U.S.A., PUERTO RICO OR U.S. VIRGIN ISLANDS...

Take the product to a Philips factory service center (see enclosed list) or authorized service center for repair. When the product has been repaired, you must pick up the unit at the center. Centers may keep defective parts. (In U.S.A., Puerto Rico and U.S. Virgin Islands, all implied warranties, including implied warranties of merchantability and fitness for a particular purpose, are limited in duration to the duration of this express warranty. But, because some states do not allow limitations on how long an implied warranty may last, this limitation may not apply to you.)

TO GET WARRANTY SERVICE IN CANADA...

Please contact Philips at:

1-800-661-6162 (French Speaking)

1-800-363-7278 (English Speaking)

(In Canada, this warranty is given in lieu of all other warranties. No other warranties are expressed or implied, including any implied warranties of merchantability or fitness for a particular purpose. Philips is not liable under any circumstances for any direct, indirect, special, incidental or consequential damages, howsoever incurred, even if notified of the possibility of such damages.)

REMEMBER...

Please record the model and serial numbers found on the product below. Also, please fill out and mail your warranty registration card promptly. It will be easier for us to notify you if necessary.

MODEL # _____

SERIAL # _____

This warranty gives you specific legal rights. You may have other rights which vary from state/province to state/province.

Philips Service Solutions Group, P.O. Box 2976, Longview, Texas 75606, (903) 242-4800

Download from www.Somanuals.com. All Manuals Search And Download.

EL4965E005 / MAC 4110 / 1.97

Free Manuals Download Website

<http://myh66.com>

<http://usermanuals.us>

<http://www.somanuals.com>

<http://www.4manuals.cc>

<http://www.manual-lib.com>

<http://www.404manual.com>

<http://www.luxmanual.com>

<http://aubethermostatmanual.com>

Golf course search by state

<http://golfingnear.com>

Email search by domain

<http://emailbydomain.com>

Auto manuals search

<http://auto.somanuals.com>

TV manuals search

<http://tv.somanuals.com>