

IMPORTANT SAFETY INSTRUCTIONS

When using an electrical appliance, basic safety precautions should always be followed, including the following:

Read all instructions before using this appliance.

DANGER

To reduce the risk of electric shock:

- Do not reach for a Trimmer that has fallen into water. Unplug immediately.
- Do not use while bathing or in a shower.
- Do not place or store Trimmer where it can fall or be pulled into a tub or sink. Do not place in or drop into water or other liquid.
- Always unplug this Trimmer from the electrical outlet immediately after using, except when Trimmer is (re)charging.
- Unplug Trimmer before cleaning.
- When **discarding** Trimmer, unplug Trimmer to remove rechargeable battery. See Battery Removal instruction sheet.

WARNING

To reduce the risk of burns, fire, electric shock or injury to persons:

- Close supervision is necessary when this appliance is used by, on, or near children or invalids.
- Use this Trimmer for its intended household use as described in this manual. Do not use attachments not recommended by the Philips Electronics North America Corporation.
- Never operate this Trimmer if it has a damaged cord or plug, if it is not working properly, if it has been dropped, damaged, or dropped into water. Return the Trimmer to an Authorized Norelco Service Location for examination and repair.
- Keep the Trimmer and cord away from heated surfaces.
- Never drop or insert any object into any opening. Keep air openings free of lint, hair, etc.
- Do not charge or plug in Trimmer outdoors or where aerosol (spray) products are being used or where oxygen is being administered.
- Do not use this Trimmer with a damaged or broken cutter, as facial injury may occur.
- Do not operate Trimmer with the hair collection chamber removed.
- Always attach plug to Trimmer first, then into outlet. To disconnect, turn ON/OFF switch "OFF" then remove plug from outlet.
- To prevent possible damage to the cord, do not wrap cord around the Trimmer.
- Never put Trimmer in direct sunlight or store in a pouch at a temperature above 140°F.
- This Trimmer is for use on human facial hair only. Do not use this Trimmer for any other purpose.

SAVE THESE INSTRUCTIONS

IMPORTANT: YOUR TRIMMER CONTAINS A NICKEL-CADMIUM RECHARGEABLE BATTERY. See Battery Removal instruction sheet.

Features

- A Patented Acu•Control System with Removable Guide Comb Attachment
- B Detachable Cutting Unit with 3-Dimensional Rounded Stainless Steel Cutter Blades.
- C Flexi-Guard Hair Deflector
- D Clear View Hair Collection Chamber
- E Filter
- F Precision Zoom Lock Hair Length Selector with 9 Pre-select Settings
- G Selected Hair Length Setting Window
- H ON/Off Button
- I Charging Indicator Light
- J Power Cord Socket
- K Cord
- L Cleaning Brush
- M Travel/Storage Pouch
- N Full Two-Year Warranty
- O 60-Day Money-Back Guarantee

Charging

Charge the Trimmer fully before you start using it for the first time or after a long period of disuse.

To Charge / Recharge

- ▶ (Re)charging requires 10 full hours.
- ▶ Use only the cord provided.
- ▶ Battery performance is best if you recharge only when the battery is (almost) completely empty.
- ▶ Charging or recharging at temperatures below 40°F or higher than 95°F adversely affects lifetime of battery.
- ▶ Continuously recharging or continuously using as a corded Trimmer will reduce life of battery.
- ▶ You may also trim using the cord provided. This Trimmer will not recharge while being used corded.

- Be certain Trimmer is OFF.
- Connect cord to Trimmer. Plug into any 120V AC outlet only. Use only the cord provided.

- ▶ The green Charging Indicator light will go on to indicate the Trimmer is charging (fig.2).

- ▶ An adaptor plug may be necessary for cord usage in some foreign countries. Use an attachment plug adaptor of the proper configuration for power outlet.

Do not charge Trimmer in a pouch or for more than 24 hours.

- ▶ It requires 10 hours to fully charge the battery.
 - ▶ A fully charged Trimmer has a cordless trimming time of up to 40 minutes.
- Disconnect the cord and unplug from electrical outlet unless you are using the Trimmer corded.

Optimize The Working Life Of The Battery

- ▶ After Trimmer has been charged for the first time, do not recharge Trimmer between trimming sessions. Continue using it until the battery is completely empty.
- ▶ Discharge the battery completely twice a year by letting the motor run until it stops.
- ▶ Do not charge for more than 24 hours.
- ▶ Do not keep cord permanently plugged in.
- ▶ If Trimmer hasn't been used for a long period of time, Trimmer must be recharged for 10 full hours.

Corded Trimming

- Connect cord provided to Trimmer.
- Plug Trimmer into electrical outlet.
- If battery is completely empty, wait a few minutes before switching Trimmer on.
- Turn Trimmer ON and begin trimming.
- Turn Trimmer OFF and unplug.
- Do not use Trimmer corded when battery is fully charged.

NOTE: Trimmer does not recharge during cord trimming.

Cordless Trimming

- Charge according to directions. Unplug Trimmer from outlet and remove cord.
- Turn Trimmer ON to begin trimming.
- If charge runs out while trimming, simply connect cord provided to Trimmer and continue trimming.

Put It To The Test

Like many new products, your Norelco AccuVac Trimmer may take a little getting used to. If you are using an electric Trimmer for the first time, or if you've been using a different brand, take the time to acquaint yourself with your new Trimmer.

Your AccuVac Trimmer features the Patented Acu•Control System combined with an adjustable Zoom Lock to make trimming facial hairs goof-proof. The integrated AccuVac System collects cut-off hairs during use.

Throw your scissors away and put your new AccuVac Trimmer to the test. We guarantee precise, professional, results or Norelco will refund you the full purchase price, guaranteed!

Acu•Control System

The patented Acu•Control System puts you in complete control while trimming your facial hairs with no prior experience needed. The flexing Guide Comb adjusts automatically to hug the contours of your face for a trim that is both even and accurate. And, it's easy to maneuver over those hard-to-reach areas such as the throat and chin. The patented Zoom Lock Hair Length Selector allows you to choose among 9 preset hair lengths and locks into position so you can control the exact hair length you desire or vary the length of your facial hair. The Patented Acu•Control System and Zoom Lock Hair Length Selector for professional, goof-proof results every time.

AccuVac System

The AccuVac System is activated automatically as soon as you switch the trimmer on. It collects cut hairs during every kind of use, i.e. trimming with or without comb attachment and contouring. The flexible hair guide follows the contours of the face and the Flexi-Guard Hair Deflector directs cut hairs towards the nozzle of the vacuum mechanism. It is recommended that you empty the Hair-Collection Chamber after each trimming session. When trimming long, dense beards it may also be necessary to empty the Hair-Collection Chamber during the trimming session in order to maintain optimal suction performance (also see 'Cleaning' section, 'Hair-Collection Chamber').

- ▶ To ensure optimal functioning of the AccuVac System, do not cut off more than approx. 7mm of your overall beard length at a time. If you want to cut your beard shorter, repeat the process one or more times.

Trimming

- ▶ Use this Trimmer for its intended household use as described in this manual.
- ▶ Always comb your beard and/or moustache with a fine comb before you start trimming.
- ▶ If you are trimming for the first time, be careful. Do not move the Trimmer too fast. Make smooth and gentle movements.

Trimming With ACU•CONTROL Guide Comb Attachment

- ▶ Guide Comb Attachment must be on Trimmer in order to use the Zoom Lock.

- Turn the Zoom Lock to the desired trimming length setting (see table). The setting will appear in the window below the Zoom Lock (fig. 3).

- ▶ If you are trimming for the first time, start by using the maximum trimming length setting #9 to prevent accidentally trimming hairs too short. As you become familiar with the settings, adjust Zoom Lock to desired trimming length. Zoom Lock will "click" into position at each setting.

Features

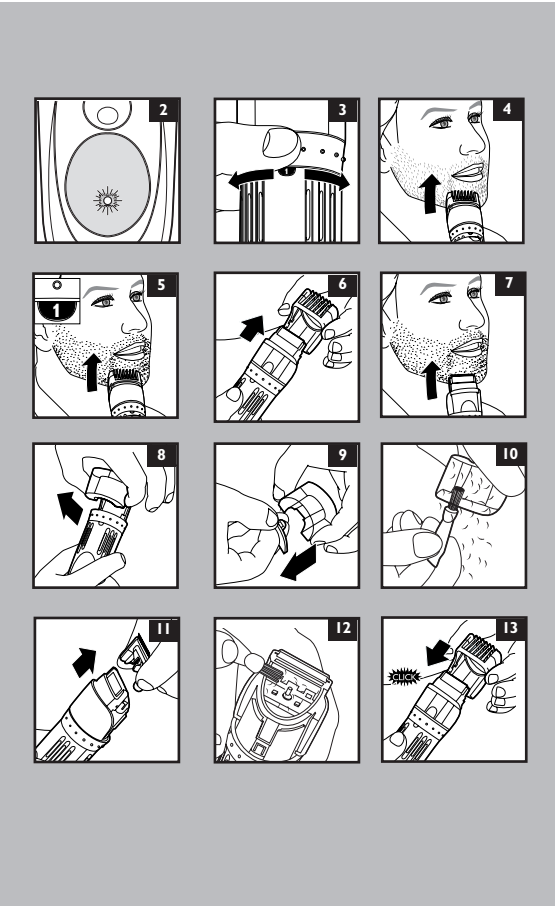
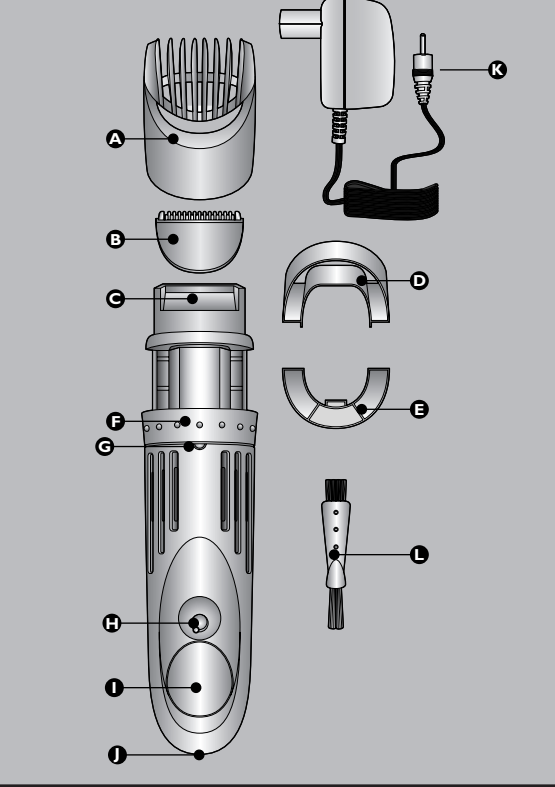

Trimming Length Settings Table

#1	Stubble Length or Closely Cropped	.06 in./1.5 mm
#2	Short	.1 in./2.5 mm
#3		.16 in./4 mm
#4		.22 in./5.5 mm
#5	Medium	.3 in./7.5 mm
#6		.38 in./9.5 mm
#7		.48 in./12 mm
#8		.6 in./15 mm
#9	Long	.72 in./18 mm

- Switch the Trimmer ON.
- To trim in the most effective way, move the Trimmer against the direction of hair growth. Do not move the trimmer too fast. Make smooth and gentle movements and make sure the surface of the Guide Comb always stays in contact with the skin (fig. 4).

NOTE: Since all hairs do not grow in the same direction, you may want to try different trimming positions (i.e., upwards, downwards, or across). Practice is best for optimum results.

Trimming For "Stubble" Look

- Be certain Guide Comb is on Trimmer and use setting #1 to result in a "stubble" look. (fig. 5).

Trimming Without Guide Comb Attachment

Remove Guide Comb Attachment if you are:

- ▶ Defining hair lines
- ▶ Trimming nape of neck
- ▶ Removing single, unwanted hairs

- Be certain Trimmer is in the OFF position.
- Remove the Guide Comb Attachment by pulling it off the Trimmer (fig. 6).

Never pull off the Guide Comb Attachment by grasping the flexible top portion. Always pull off by the bottom part of attachment.

- Switch the Trimmer on.
- Make well-controlled movements. Touch the hair lightly with the Trimmer (fig. 7).

Replacing Guide Comb Attachment On Trimmer

- Be certain Trimmer is in OFF position.
- Replace Guide Comb Attachment until it "clicks" into position. The Guide Comb Attachment can be placed on Trimmer only one way by properly aligning it to slide into the tracks on sides of Trimmer head. If it does not fit properly, reverse it.

NOTE: The Zoom Lock can be on any setting when removing or replacing Attachment.

Cleaning

- ▶ Always switch Trimmer OFF before cleaning.
- ▶ Do not use abrasive, scourers or liquids such as alcohol, benzene, bleach or acetone to clean the Trimmer.
- ▶ Never clean, remove or replace Guide Comb Attachment with motor ON.
- ▶ Do not apply pressure to cutters.
- ▶ Do not touch cutters with hard objects as this may damage them.
- ▶ Do not use while bathing, showering or immerse the Trimmer in water or other liquids as damage to Trimmer may occur.
- ▶ Never use sharp or hard objects to clean the filter to avoid damaging it.
- ▶ If cut hairs have accumulated in the Guide Comb area, turn Trimmer off, pull Guide Comb Attachment off Trimmer and remove hairs by shaking and/or blowing.

Hair Collection Chamber

- Switch the Trimmer off.
- Remove the Clear View Hair Collection chamber and remove the hairs by shaking or brushing them out (fig. 8).
- For extra thorough cleaning and to maintain optimal suction performance, detach the filter... (fig. 9).
- ...and carefully clean the Clear View Hair Collection Chamber and the filter with the brush supplied (fig. 10).

- ▶ When trimming extremely long, dense beards, it may be necessary to empty the Hair Collection Chamber during the trimming session in order to maintain optimal suction performance.
- ▶ If suction performance is not as strong as usual, Hair Collection Chamber may require emptying to restore optimal performance.

- ▶ It is recommended that the Hair Collection Chamber be emptied and cleaned out after each use.
- ▶ Do not operate the Trimmer with the Hair Collection Chamber removed.

Trimmer:

- Make sure the Trimmer is switched OFF and disconnected from the electrical outlet.
- Remove the Guide Comb Attachment.
- Remove the cutting unit (fig. 11).
- Clean the cutting unit and the inside of the Trimmer with the brush supplied (fig. 12).
- Re-attach the cutting unit and the Guide Comb into place on the Trimmer (fig. 13).

Replacing The Cutting Unit

If your cutters and filter become damaged or worn, do not continue using the Trimmer. Replace cutters and/or filter immediately.

This Trimmer has no other user-serviceable parts. Any other service should be performed by an Authorized Norelco Service Location.

Assistance

For Assistance or the Authorized Norelco Service Location nearest you, call toll free:

1-800-243-3050
or visit our website: www.norelco.com

Authorized Norelco Service Location information is available 24 hours a day, 7 days a week.

Storage

- ▶ Be sure Trimmer is turned off and remove cord from outlet and Trimmer before storing in a safe, dry location where it will not be crushed, banged, or subject to damage.
- ▶ Do not wrap cord around Trimmer when storing.
- ▶ Store Cord in a safe location where it will not be cut or damaged.
- ▶ Do not place or store Trimmer where it can fall or be pulled into a tub or sink, water or other liquid.

Battery Removal

- ▶ This Trimmer contains rechargeable Nickel-Cadmium batteries, which must be disposed of properly.
- ▶ Batteries should only be removed when Trimmer is to be discarded.
- ▶ Refer to Battery Removal instruction sheet for directions on removing the rechargeable batteries.

FULL TWO-YEAR WARRANTY
Philips Electronics North America Corporation warrants each new Norelco product, Model T-870 against defects in materials or workmanship for a period of two years (cutters for up to seven years) from the date of purchase, and agrees to repair or replace any defective product without charge.

IMPORTANT: This warranty does not cover damage resulting from accident, misuse or abuse, lack of reasonable care, the affixing of any attachment not provided with the product or loss of parts or subjecting the product to any but the specific voltage.* Use of unauthorized replacement parts will void this warranty.

PHILIPS ELECTRONICS NORTH AMERICA CORPORATION WILL NOT PAY FOR WARRANTY SERVICE PERFORMED BY A NON-AUTHORIZED REPAIR SERVICE AND WILL NOT REIMBURSE THE CONSUMER FOR DAMAGE RESULTING FROM WARRANTY SERVICE PERFORMED BY A NON-AUTHORIZED REPAIR SERVICE.

NO RESPONSIBILITY IS ASSUMED FOR ANY SPECIAL, INCIDENTAL OR CONSEQUENTIAL DAMAGES.
In order to obtain warranty service, simply take or ship the product postage prepaid to the nearest Authorized Norelco Service Location. It is suggested that for your protection you return shipments of product by insured mail, insurance prepaid. Damage occurring during shipment is not covered by this warranty. **NOTE:** No other warranty, written or oral, is authorized by Philips Electronics North America Corporation. This warranty gives you specific legal rights, and you may also have other rights which vary from state to state. Some states do not allow the exclusion or limitation of incidental or consequential damages, so the above exclusion and limitations may not apply to you.

*Read enclosed instructions carefully.
Manufactured for Norelco Consumer Products Company
A Division of Philips Electronics North America Corporation
1010 Washington Blvd., Stamford, CT 06912-0015

MADE IN AUSTRIA.
This symbol on the product's nameplate means it is listed by Underwriters Laboratories, Inc.

Norelco and ACU•CONTROL are Registered Trademarks of Philips Electronics North America Corporation.
AccuVac, Clear View, and Zoom Lock are Trademarks of Philips Electronics North America Corporation.

PHILIPS is a Registered Trademark of Koninklijke Philips Electronics N.V.
© 2003 Philips Electronics North America Corporation. All Rights Reserved.



Beard and Moustache Trimmer



T870
Rechargeable Cord/Cordless
PHILIPS
4203 000 5338 1

NORELCO

60-DAY MONEY-BACK GUARANTEE

If you are not fully satisfied with your Norelco Beard and Moustache Trimmer, send the product back and we'll refund you the full purchase price.

The Trimmer must be shipped prepaid by insured mail, insurance prepaid, and have the sales receipt, indicating purchase price and the date of purchase, enclosed. The Trimmer must be postmarked no later than 60 days after the date of purchase. Norelco reserves the right to verify the purchase price of the Trimmer and limit refunds not to exceed suggested retail price.
Send dated sales receipt, your complete name and address as indicated below, and the Trimmer, prepaid to:

Norelco Consumer Products Company
A Division of Philips Electronics North America Corporation
450 North Medinah Road, Dock 16
Roselle, IL 60172-2329

Please allow 4-6 weeks for delivery of check. (Please Print)

Name _____

Address _____

City _____

State _____ Zip _____

Daytime Telephone No. (____) _____

Email Address: _____ AREA CODE _____

REASON FOR RETURNING: _____

Free Manuals Download Website

<http://myh66.com>

<http://usermanuals.us>

<http://www.somanuals.com>

<http://www.4manuals.cc>

<http://www.manual-lib.com>

<http://www.404manual.com>

<http://www.luxmanual.com>

<http://aubethermostatmanual.com>

Golf course search by state

<http://golfingnear.com>

Email search by domain

<http://emailbydomain.com>

Auto manuals search

<http://auto.somanuals.com>

TV manuals search

<http://tv.somanuals.com>