

# APPLICATION NOTE

**AN1651**

Using the NE/SA5234 amplifier

Author: Les Hadley

1991 Oct

## Using the NE/SA5234 amplifier

## AN1651

Author: L. Hadley

2.5MHz is retained. Slew rate is  $0.8\text{V}/\mu\text{s}$  and each op amp will settle to a 1% of nominal level within  $1.4\mu\text{s}$ .

## I. SUMMARY

The NE/SA5234 is a unique low-voltage quad operational amplifier specifically designed to operate in a broadly diverse environment. It is an enhanced pin-for-pin replacement for the LM324 category of devices. Supply conditions can range from 1.8V to 6.0V with a resultant current drain of  $2.8\text{mA}$ ,  $-700\mu\text{A}$  per op amp.

Most notable are the input and output dynamic range characteristics of the individual op amps. The common-mode input voltage can actually exceed the positive and negative supply rails by  $250\text{mV}$  with no danger of output latching or polarity reversal. In addition, the output of each op amp will swing to within  $50\text{mV}$  of the supply rails over the full supply range.

The frequency related characteristics are also above average for low voltage devices in this class. Internal unity gain compensation makes the NE5234 very resistant to any tendency to oscillate in low closed-loop gain configurations. Even so, a unity-gain bandwidth of

## II. DETAILED DESCRIPTION

### Input Stage

The input differential amplifier consists of a compound transistor structure of parallel NPN and PNP transistors which account for the unique over-drive characteristics of the NE5234. Referring to Figure 1, it is seen that the NPN pair, Q1 and Q2, allow the input to operate in the common-mode input voltage range of  $1\text{V}$  above  $V_{EE}$ . This region is designated the N-mode region in Figure 3a. Operation in the common-mode range below  $1\text{V}$  transfers the input stage into the P-mode of operation.

In the N-mode operating condition, collector current from Q1 and Q2 is summed in the output emitter node of Q10 and Q12 respectively. Q1's base is the non-inverting input and Q2's base the inverting input node for the amplifier.

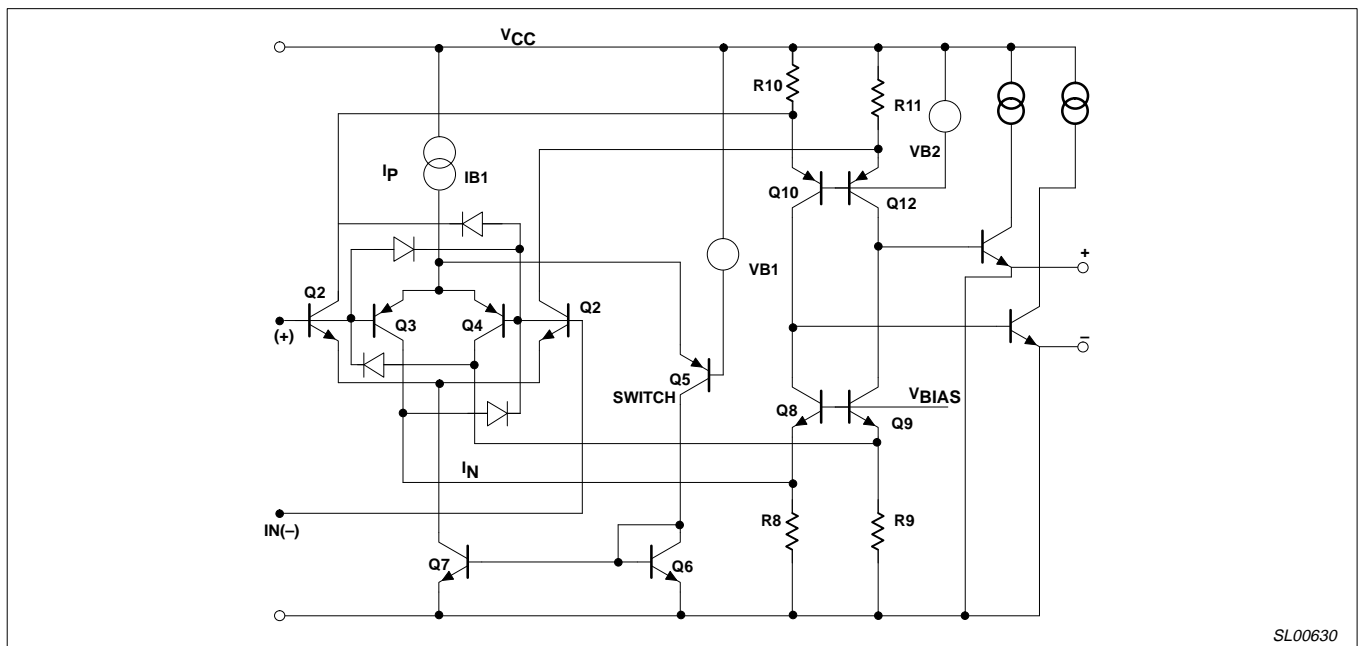

Figure 1. NE5234 Input Stage

Linear operation between the two modes is governed by a current steering circuit consisting of Q5,6 and 7 in conjunction with voltage reference VB1. Operation in the

N-region of the common-mode range will automatically cause Q5 to transfer the IB1 current source to Q7 and the NPN transistor pair Q1 and Q2. Operation below the  $1\text{V}$  level at the inputs allows the current from IB1 to be fed directly to Q3 and Q4 emitters giving them priority in processing the signal and linearizing their transfer function. (The sum of the NPN and PNP input pair currents remain constant.)

Operation in the common-mode range near the positive supply rail would normally cause the input stage NPN transistor's base

collector junction to become forward biased (base current flow directly to the collector circuit) reversing the collector current flow direction. In a conventional op amp, this would have the adverse effect of reversing the output signal polarity as the operating region is traversed by the input signal. (see Figure 2)

To prevent this from occurring, large geometry diode-connected transistors are cross-connected to the opposite NPN collector, (Q1, Q2). This current, in turn, is summed at the emitter of Q12 pulling it above the  $V_{CC}$  rail voltage and preventing polarity reversal. The inverse condition occurs when Q2 is driven above the positive rail, with Q10 emitter being pulled up and signal polarity preserved. (See Figure 1)

# Using the NE/SA5234 amplifier

AN1651

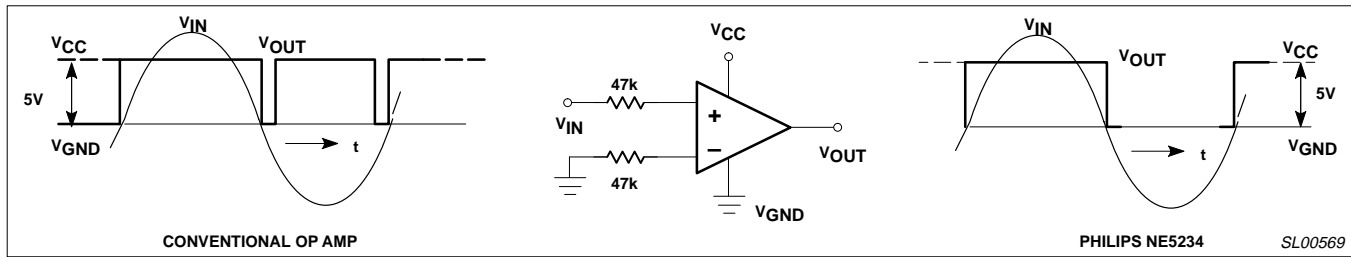

Figure 2. Output Inversion Protection

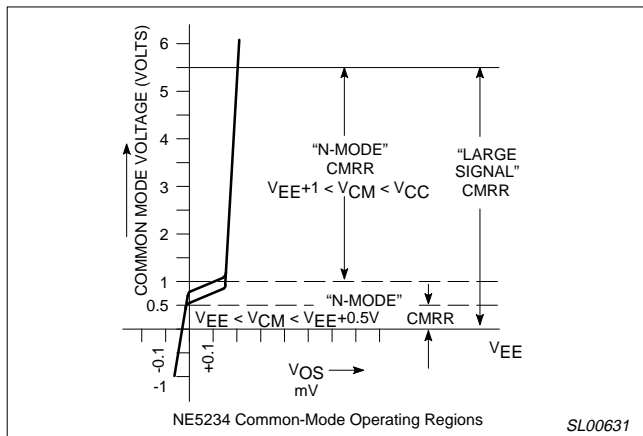

Figure 3.

For negative going input signals, which drive the inputs toward the  $V_{EE}$  rail and below, another set of diode-connected transistors come into operation. These steer the current from the input into Q8 or Q9 emitter circuits again preventing the reversal effect.

Figure 3 shows graphically how the N and P mode transitions relate to the common-mode input voltage and the offset voltage  $V_{OS}$ .

## Intermediate Amplifier and Output Stage (Figure 4)

The intermediate stage is isolated from the input amplifier by emitter followers

to prevent any adverse loading effect. This stage adds gain to the over all amplifier and translates levels for the following class-AB current-control driver. Note that  $I_2$  is the inverting input and  $I_1$  the

non-inverting input. The output is taken from multiple collectors on the non-inverting side and provides matching for the following stage.

Class-AB control of the output stage is achieved by Q61 and Q62 with the associated output current regulators. These act to monitor the smallest current of the non-load supporting output transistor to keep it in conduction. Thus, neither Q71 or Q81 is allowed to cutoff but is forced to remain in the proper Class-AB region.

Overload protection is provided by monitor circuits consisting of R76-D2 for sinking and R86-D3 for sourcing condition at the output. When the output current, source or sink, reaches 15 milliamperes, drive current to the stage is shunted away from current sources IB6 or IB9 reducing base current to driver transistors Q72 and Q82 respectively.

The prevention of saturation in the output stage is achieved by saturation detectors Q78 and Q88. When either Q71 or Q81 approaches saturation, current is shunted away from the driver transistors, Q72 or Q83 respectively.

## III. CHARACTERISTICS

### Internal Frequency Compensation

The use of nested Miller capacitors C2 through C6, in the intermediate and output sections, provides the overall frequency compensation for the amplifier. The dominant pole setting capacitor, C2, provides a constant 6dB/octave roll-off to below the unity gain frequency of 2.5MHz. Figure 5 shows the measured frequency response plot for various values of closed-loop gains.

# Using the NE/SA5234 amplifier

AN1651

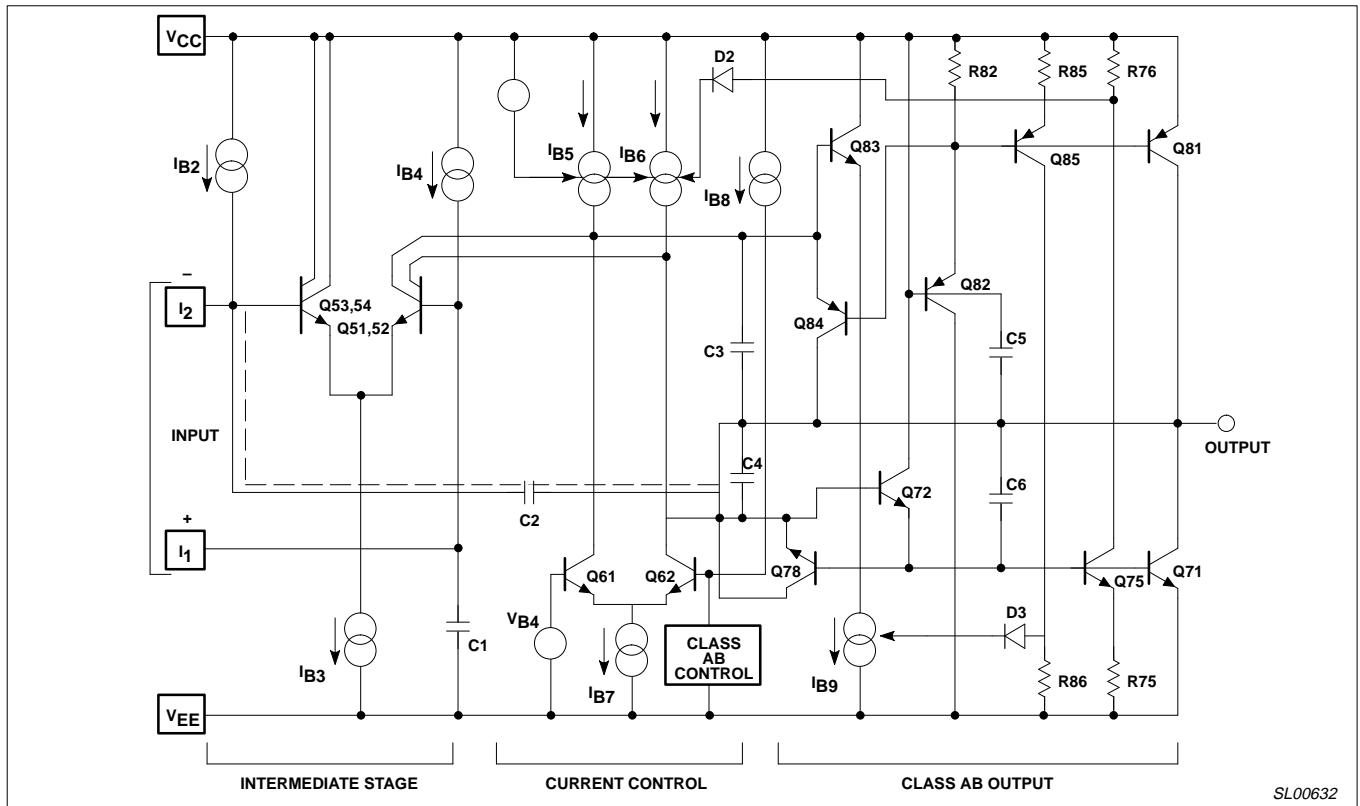

Figure 4.

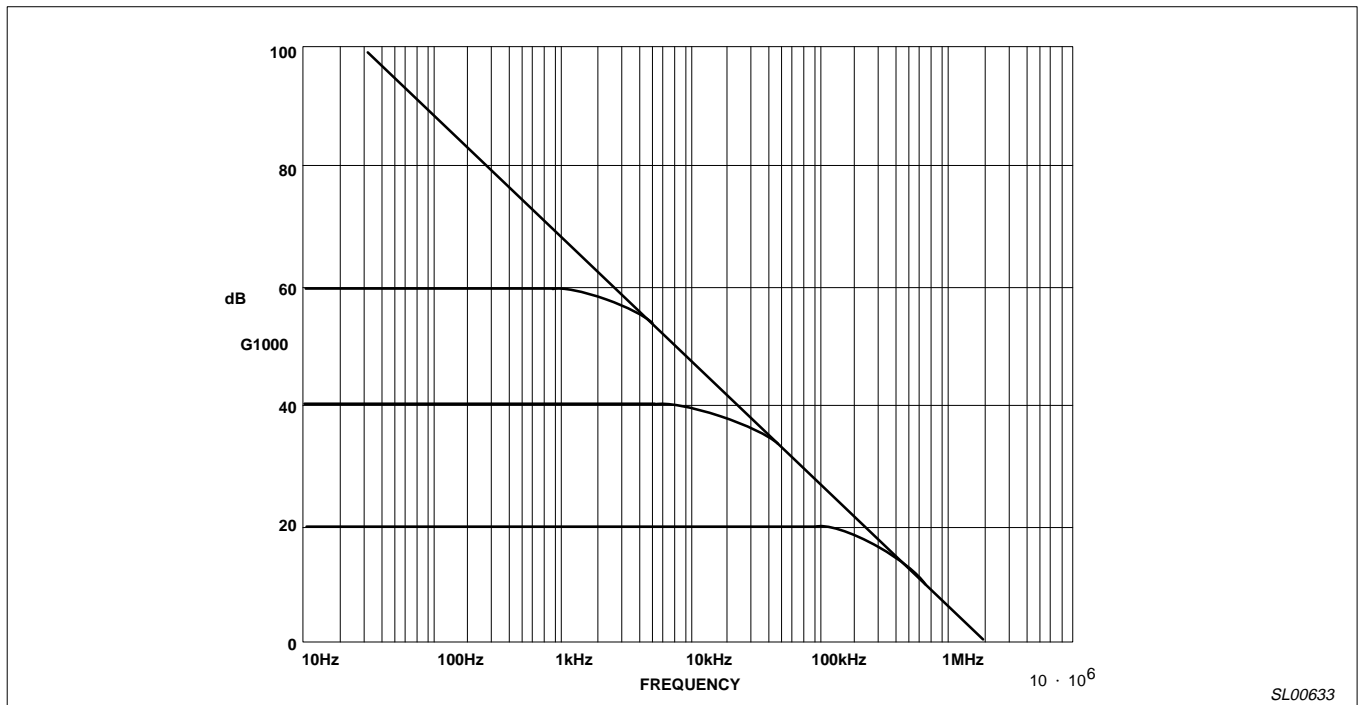

Figure 5. NE5234 Closed Loop Gain vs Frequency

# Using the NE/SA5234 amplifier

AN1651

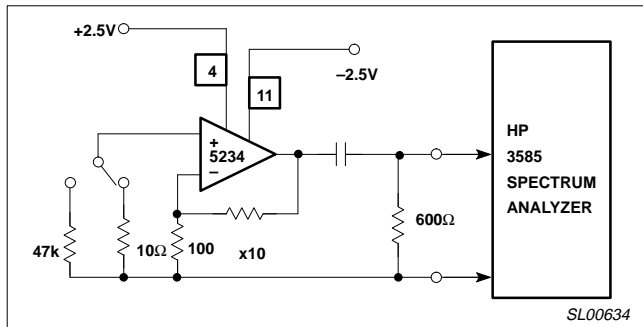

Figure 6. Noise Test Circuit

## IV. NOISE REFERRED TO THE INPUT

The typical spectral voltage noise referred to each of the op amps in the NE/SA5234 is specified to be 25nV/√Hz. Current noise is not specified. In the interest of providing a balance of information on the device parameters, a small sample of the standard NE5234s, were tested for input noise current. While this data does not represent a specification, it will give the designer a ball park figure to work with when beginning a particular design with the device. For completeness I have provided the corresponding spectral noise voltage data for the same sample. The data was taken using an HP3585A spectrum analyzer which has the capability of reading noise in nV/√Hz.

The test circuit is shown in Figure 6. As is typical for such measurements the amplifier under test is terminated at its input first with a very low resistance, for the voltage noise reading, followed by the same test with a high value of resistance to register the effect of current noise. The amplifier is set to a non-inverting closed-loop gain of 20dB. Dual supply operation was chosen to allow direct termination of the input resistors to ground.

The measurements were made over the range from 200Hz to 2kHz. Each sample is measured at 200Hz, 500Hz, 1kHz and 2kHz. The data is averaged for each frequency and then the small sample distribution is derived statistically giving the standard deviation relative to the mean.

Referring to the graph in Figure 7a, the equivalent voltage noise is seen to average 18 nV/√Hz. The 95% confidence interval is determined to be approximately one nV/√Hz. The majority of the errors which contribute to this measurement are due to the thermal noise of the parallel combination of the feedback resistor network, in addition to the 10Ω termination resistor on the non-inverting input. At 300° Kelvin a 10Ω resistor generates 0.4 nV/√Hz and the feedback network's equivalent resistance of 90Ω generates 1.2nV/√Hz. Their order-of-magnitude difference from the main noise sources allows them to be neglected in the overall calculation of total stage noise.

Noise current is measured across a 47kΩ resistor and averaged in the same manner. The thermal noise generated by this large resistance is not insignificant. At room temperature it is 28nV/√Hz and must be subtracted from the total noise as measured at the output of the op amp in order to arrive at the equivalent current generated noise voltage. Figure 7b shows the derived current noise distribution for the small sample of 10 NE5234 devices. The result shows that noise current in the 200Hz to 2kHz frequency is

typically 0.2pA/√Hz. The 1/f region was not determined for either current or voltage noise.

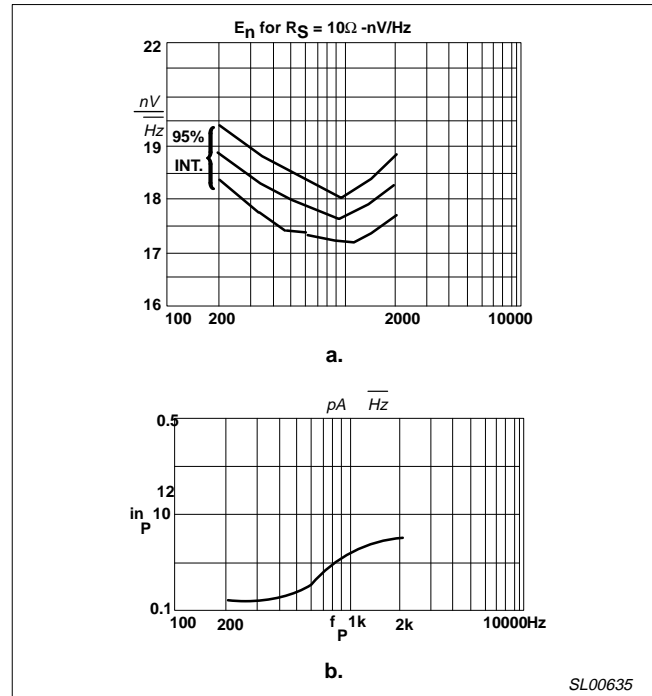

Figure 7. Typical Noise Current and Voltage vs Frequency

## V. GUIDE LINES FOR MINIMIZING NOISE

When designing a circuit where noise must be kept to a minimum, the source resistances should be kept low to limit thermally generated degradation in the overall output response.

Orders-of-magnitude should be kept in mind when evaluating noise performance of a particular circuit or in planning a new design. For instance, a transducer with a 10kΩ source resistance will generate 2μV of RMS noise over a 20kHz bandwidth. Using the graphical data above, total noise from a gain stage may be calculated.-

$$\text{Amplifier Noise Voltage} \tag{EQ. 1.}$$

$$25\text{nV} \sqrt{\text{Hz}} \cdot \frac{\text{BW}}{10\text{kHz}} = 3.5\mu\text{V}_{\text{RMS}}$$

Noise from source 10kΩ Resistance –

$$\text{Noise Voltage from source resistance} \tag{EQ. 2.}$$

$$14\text{nV} \sqrt{\text{Hz}} \cdot \frac{\text{BW}}{20\mu\text{V}_{\text{RMS}}}$$

$$\text{Current generated noise} \tag{EQ. 3.}$$

$$0.2\text{pA} \sqrt{\text{Hz}} \cdot 10^3 \cdot \frac{\text{BW}}{0.28\mu\text{V}_{\text{RMS}}}$$

The total noise is the root-to-sum-of-the-squares of the individual noise voltages –

$$E_n = \sqrt{(3.5)^2 + (2.0)^2 + (0.28)^2} = 4.04\mu\text{V}_{\text{RMS}} \tag{EQ. 4.}$$

To determine the signal-to-noise ratio of the stage we must first choose a stage gain, make it 40dB, and a signal voltage magnitude from the transducer which we will set at 10mV<sub>RMS</sub>. The resulting

# Using the NE/SA5234 amplifier

AN1651

signal-to-noise ratio at the output of this stage is determined by first multiplying the gain times the signal which gives  $1V_{RMS}$  with a resultant noise of  $400mV_{RMS}$ . The signal-to-noise ratio is calculated as

$$S/N = 20 \log_{10} (1.0 \times 4 \times 10^{-4}) = 68dB \quad (EQ. 5.)$$

This is quite adequate for good quality audio applications.

Next assume that the bandwidth is cut to 3.0kHz with an input of  $1mV_{RMS}$ . The RMS noise is modified by the ratio of the root of the noise channel bandwidths.

$$\frac{\sqrt{3 \times 10^3}}{20 \times 10^3} \cdot EN = 1.6 \mu V_{RMS} \quad (EQ. 6.)$$

Amplified Noise =  $160 \mu V_{RMS}$

$$S/N = 20 \log_{10} \frac{100 \times 10^{-3}}{1.6 \times 10^{-4}} \quad (EQ. 7.)$$

56dB

A 56dB S/N will provide superior voice channel communications .

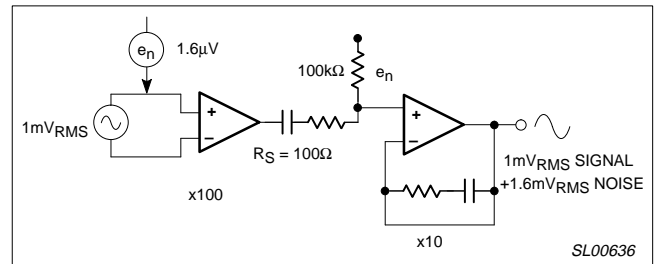

Figure 8.

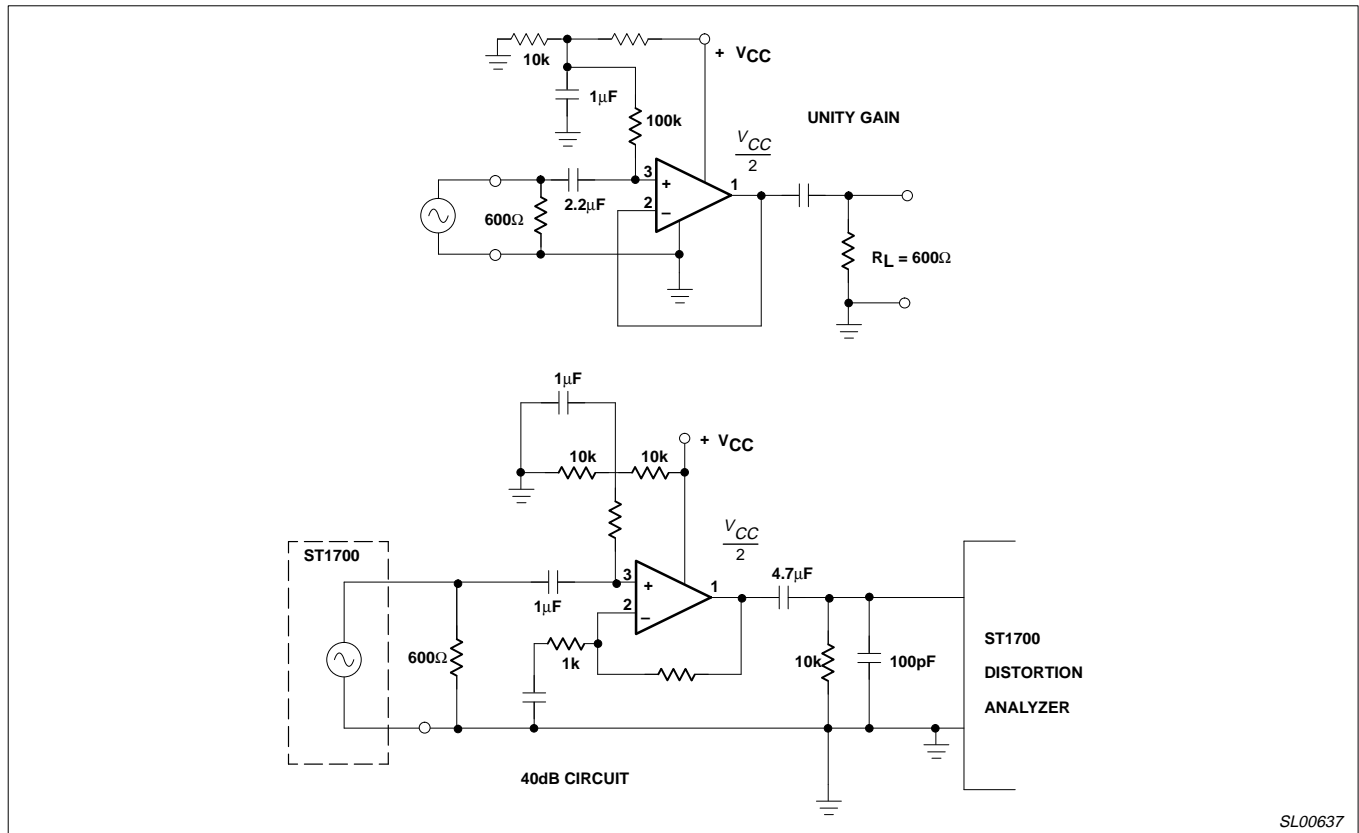

Figure 9. NE5234 THD Test Circuits

## VI. MULTIPLE STAGE CONSIDERATIONS

Since multiple noise generators are non-coherent, their total effect is the root-of-the-sum-of-the-squares of the various noise generators at a given amplifier input.

This makes orders-of-magnitude lower noise sources less important than the higher magnitude source. Therefore, when considering the combined signal-to-noise of multiple stages of gain, the first stage in a chain dominates making its design parameters the most critical.

For this reason it is good practice to make the preamp stage gain as high as practical to boost signal levels to the second stage allowing at least an order-of-magnitude above the second-stage noise. For

instance, a signal input which exceeds the input noise of the following stage by a factor of 10:1 will only be degraded by 0.5% or -46dB, neglecting the first-stage noise. If we use the preceding example with a first-stage output signal of  $100mV_{RMS}$  and a 56dB S/N, and an output noise of 0.16mV. Following this with a 10kHz band limited gain-of-10 second-stage, with a  $100k\Omega$  noise source at the non-inverting input, the combined S/N is calculated as follows: (assume a  $100\Omega$  source resistance from amplifier #1)

The Second stage output noise is:

# Using the NE/SA5234 amplifier

AN1651

$$\frac{(0.163 \times 10^{-3})^2}{4KT \cdot 100 \cdot 10,000^2} \cdot 10 \quad (\text{EQ. 8.})$$

1.6mV

$$K \quad \text{Boltzman sConstant} \quad 1.38 \times 10^{-23} \frac{\text{Joule}}{\text{DegKelvin}} \quad (\text{EQ. 9.})$$

T 300°K ; BW 10kHz

The amplified output signal =  $1V_{RMS}$

$$S/N \quad 20 \log_{10} \frac{1}{1.6 \times 10^{-3}} \quad (\text{EQ. 10.})$$

56dB

Note that there is no effect from the second-stage thermally generated resistor noise due to the dominating effect of the first-stage amplified noise being much greater than the input noise of the second-stage. In addition the equivalent noise resistance of the second-stage is essentially the output resistance of the first-stage plus any series resistance used in coupling the two. This is the parallel combination of source resistance with input terminating or biasing resistance.

## VII. LOW HARMONIC DISTORTION

The NE/SA5234 is extremely well adapted to reducing harmonic distortion as it relates to signal level and head room in audio and instrumentation circuits. Its unique internal design limits overdrive induced distortion to a level much below that experienced with other low voltage devices. As will be shown, the device is capable of operating over a wide supply range without causing the typical clipping distortion prevalent in companion operational amplifiers of this class.

A series of tests are shown to allow you to see just how resistant this device is to generating clipping distortion. Two different gain configurations were chosen to demonstrate this particular feature: unity gain non-inverting and 40dB non-inverting. The test set-up was as shown in Figure 9. The Harmonic Distortion analyzer used to make the measurements was a Storage Technology ST1700. The test frequency is 1kHz. For single supply operation, as previously covered, the amplifier should be biased to half the supply voltage to minimize distortion. Operation with dual supplies is simpler from a parts count standpoint as isolation capacitors are not required. Also the time constants associated with charging and discharging these is eliminated. Figure 10a,b and c shows the total harmonic distortion in percent versus input voltage level at 1kHz in  $V_{RMS}$  for a non-inverting, unity gain NE5234. The load on the amplifier output is 10kΩ. Beginning with a supply voltage of 1.8V and an input level of  $0.1V_{RMS}$ , distortion is well below 0.2% and remains there up to an input level just over  $0.5V_{RMS}$  ( $1.4V_{P-P}$ ) and increases to 0.4% for  $0.6V_{RMS}$  ( $1.7V_{P-P}$ ).

For a 2V supply, the input levels increase to  $0.65V_{RMS}$  and  $0.7V_{RMS}$ , respectively for similar levels of distortion. With a supply voltage of 3.0V the input may be increased to  $1V_{RMS}$  before THD rises to 0.2% and  $1.1V_{RMS}$  for only 0.8% THD. Operation with a 600Ω load will only raise the THD figures slightly. By way of comparison, Figure 10c shows the greatly reduced dynamic range experienced when an LM324 is plugged into the test socket in place of the NE5234. Note that The THD is completely off scale for the case of 1.8 and 2.0V supply, then is barely usable for the low level end of the 3.0V supply example. Figure 11a, b, and c demonstrates the effect on harmonic distortion when closed loop gain is increased to 40dB in the non-inverting mode. It is evident that little increase in THD levels result. The graphs for the 2.0 and 3.0V supply case also include additional information on the effect of a 600Ω load on distortion.

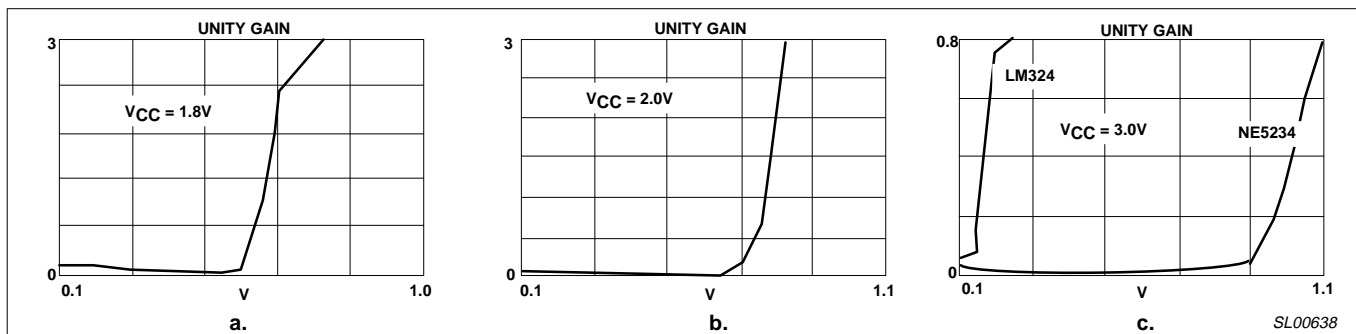

Figure 10. THD vs Supply Voltage for  $1V_{RMS}$  Output

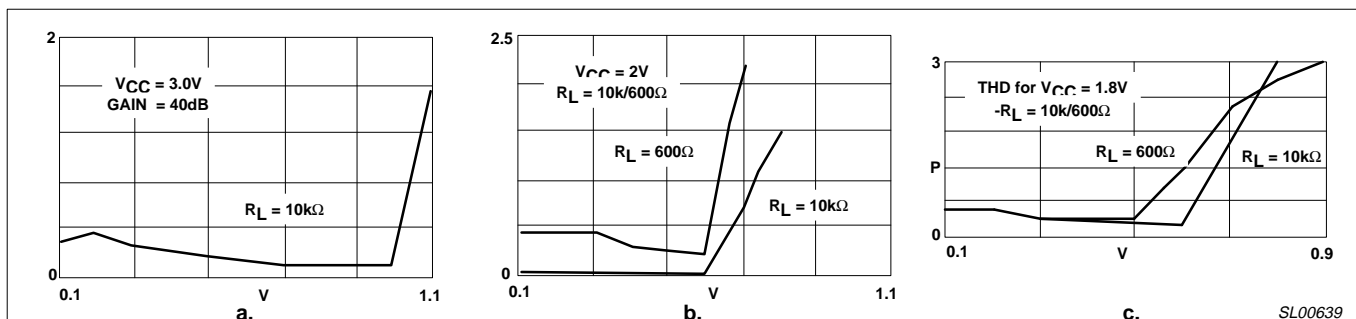

Figure 11. THD vs Load

# Using the NE/SA5234 amplifier

AN1651

## VIII. GAIN-BANDWIDTH VS CLOSED LOOP FREQUENCY RESPONSE

Figure 5 shows the small signal frequency response of the NE5234 versus closed-loop gain in dB. The test circuit is shown in Figure 6. The plot is taken from measured data and thus shows how each value of closed-loop gain coincides with the open-loop response curve. The NE/SA5234's open-loop gain response has a uniform 6dB/octave roll-off which continues beyond 2.5MHz. This factor guarantees each op amp in the IC a high stability in virtually any gain configuration. In making these measurements, dual supplies of  $\pm 2.5V$  were used in order to allow a grounded reference plane and no coupling capacitors which might cause frequency related errors.

A critical parameter which affects the reproduction quality of complex waveforms is the gain-bandwidth-product of the operational amplifier. Essentially, this is a measure of the maximum frequency handling characteristics of any operational amplifier for a given closed-loop gain. As is evident from the graph, the NE/SA5234 has a 2.5MHz unity gain cross-over frequency — much higher than most other low voltage op amps. For comparison, the  $\mu A741$  has a gain-bandwidth-product of 1MHz, as do the LM324 and the MC3403.

## IX. LOOP-GAIN

The dynamic signal response of any closed-loop amplifier stage is a function of the Loop-gain of that particular stage. Loop-gain is equal to the open-loop gain in dB, at a given frequency, minus the closed-loop gain of the stage. The greater the Loop-gain, the lower the transfer function error of the device. Essentially, any parametric error is reduced by the factor of the Loop-gain. This includes output resistance and output signal voltage accuracy. It is good practice then to maximize Loop-gain to the degree that stage gain may be sacrificed for bandwidth. In some cases it is actually better to use two stages of gain in order to preserve signal quality than to use one high gain stage. Of course, there is a trade-off between the

mentioned factors that affect the signal-to-noise ratio of the stage and optimizing the Loop-gain. For example, a voice-band audio stage which requires 3kHz bandwidth, should be limited to a closed-loop gain of 40dB for lowest distortion in the output signal. For higher quality audio applications requiring a 20kHz bandwidth, the closed-loop gain must be limited to 20dB. This results in a Loop-gain of 20dB at the highest signal frequency.

A second consideration in the list of frequency dependent parameters is the effect of amplifier slew rate. Not only is it frequency dependent but it is also a function of signal amplitude, as we shall see in the next section.

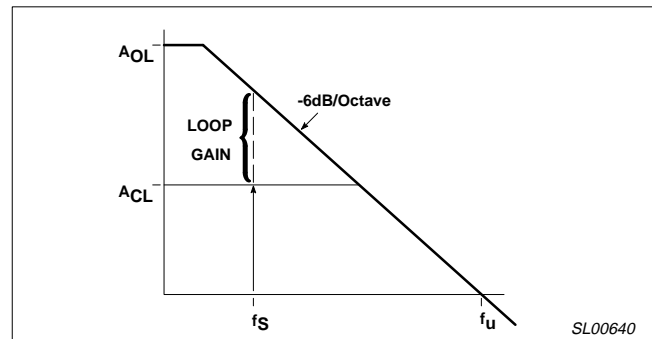

Figure 12.

## X. SLEW RATE RESPONSE

The slew rate of an operational amplifier determines how fast it can respond to a signal, and is measured in volts-per-microsecond. The NE5234 has a typical slew rate of 0.8V/ $\mu s$ . Let us see just what this means in terms of signal handling capability. If a sinusoidal input signal,  $V_S$ , is used as reference, it is specified by its frequency and peak amplitude,  $V_P$  as follows:

$$V_S = V_P \sin(2\pi f t) \tag{EQ. 11.}$$

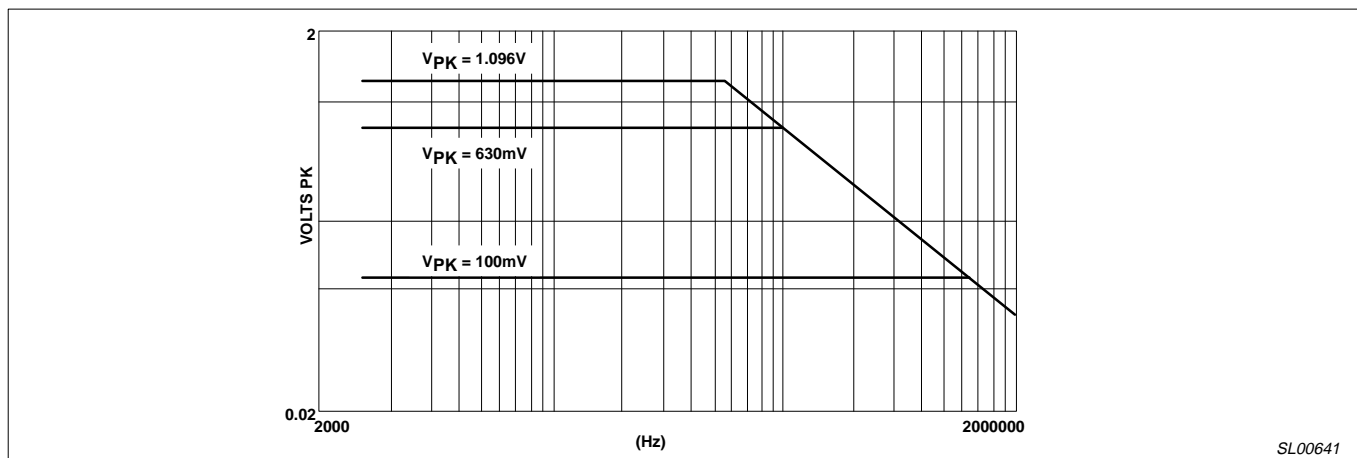

Figure 13. Slew Rate Limiting Amplitude vs Frequency

Slew Rate (SR) is the time-rate-of-change of the signal voltage during any complete cycle, that is over the range of 0 to  $2\pi$ . This amounts to taking the time derivative of the sine wave which results in multiplying the cosine by the factor  $2\pi f$ .

An example of the trade off between signal amplitude and frequency is shown below for the NE5234 slew rate of 0.8V/ $\mu s$ . As shown in

Figure 13, the maximum allowable amplitude signal which can be reproduced is determined by the slew rate response line which gives peak output volts versus frequency in Hertz.

Mathematically, slew rate is determined, by the equation below, as the derivative of the sine wave signal. The resultant slew rate function changes with both frequency and amplitude.



# Using the NE/SA5234 amplifier

AN1651

$$\text{Slew Rate} = V_P (2 f) \cos (2 f t)$$

Note that maximum slew rate occurs where the input sine wave signal crosses the values of 0,  $\pi$ , and  $2\pi$  on the radian axis. To get a feel for what this means in regards to the typical low voltage circuit, let us consider a  $1V_{RMS}$  sinusoidal input to a unity gain amplifier. The peak voltage in the above equation is 1.414V. One can then calculate the required slew rate to faithfully reproduce this signal for various signal frequencies. Or with a given slew rate and a required peak signal amplitude, the maximum frequency before slew rate limiting occurs may be determined. For example using the above amplitude of  $1V_{RMS}$ , and the slew rate of the NE5234 which is 800,000V/sec, one determines that the highest frequency component which may be reproduced before slew rate distortion occurs is:

$800,000 \text{ V/sec} / 2\pi \cdot 1.414 \text{ volts peak} = 90,090\text{Hz}$ . A graphical representation of this relationship is shown in Figure 13. By using this graph along with the information in the preceding Figure 10 and Figure 11, which relate usable signal levels versus power supply voltage, the dynamic behavior of a particular design may be predicted. For instance, given a single supply configuration operating at 2.0V, Figure 10b shows an upper limit to input amplitude of  $0.7V_{RMS}$ , or about 1V peak for 1% THD. Using this level with the data in Figure 13 leads to a figure of 116kHz as an upper frequency limit for a unity gain amplifier stage operating at 2V DC.

$$\frac{dV_S}{dt} = \frac{V_P \cos t}{\text{Slew Rate}} \tag{EQ. 12.}$$

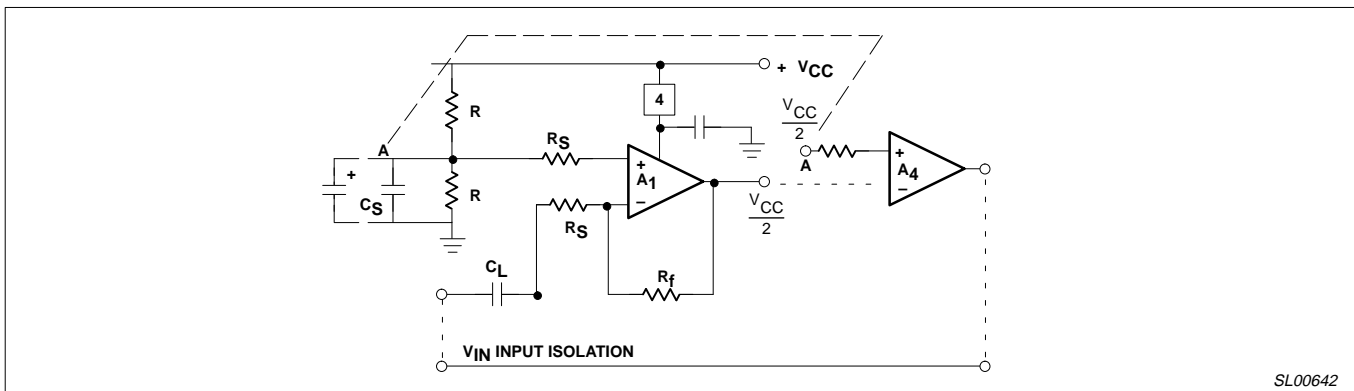

Figure 14. Single Supply Biasing in Cascade

## XI. PROCEDURES

### Single Supply Operation

When the NE/SA5234 is used in an application where a single supply is necessary, input common-mode biasing to half the supply is recommended for best signal reproduction. Referring to Figure 14, a simplified inverting amplifier input stage is shown with the simplest form of resistive divider biasing. The value of the divider resistance R is not critical and may be increased above the 10k $\Omega$  value shown as long as the bias current does not interfere with accuracy due to DC loading error. However the divider junction must be kept at a low AC impedance. This is the purpose of bypass capacitor CS. Its use provides transient suppression for signals coming from the supply bus. A low cost 0.1 $\mu$ F ceramic disk or chip capacitor is recommended for suppressing fast transients in the microsecond and sub-microsecond region.

Foil capacitors are simply too inductive for any high frequency bypass application and should be avoided. If low frequency noise such as 60Hz or 120Hz ripple is present on the supply bus, an electrolytic capacitor is added in parallel as shown. The common-mode input source resistance, RS, should also be matched within a reasonable tolerance for maximizing the rejection of induced AC noise.

The output of the first stage is now fixed at the common mode bias voltage and the amplified AC signal is referenced to this constant value. Capacitive coupling to the inverting input is of course required to prevent the bias voltage from being multiplied by the

stage gain. Second stage biasing may now be provided by the output voltage of the first stage if non-inverting operation is used in the former. For lowest noise in a high gain input stage, the magnitude of the input source resistance is critical; low values of resistance are preferred over high values to minimize thermally generated noise.

### Non-Inverting Stage Biasing

Non-inverting operation of an amplifier stage with single supply is similar to the previous example but the bias resistor RS must now be sufficiently high to allow the signal to pass without significant attenuation. The input source resistance reflects the output resistance of the preceding stage or other sourcing device such as a bridge circuit of relatively high impedance. A simple rule of thumb is to make the bias resistor an order of magnitude larger than the generator resistance. Again the feed back network must be terminated capacitively. In this case R1 and the generator resistance should be matched and then RS is matched to the feedback resistance, Rf.

In all cases proper bypassing of the NE5234 supply leads (Pins 4 and 11) is very important particularly in a high noise environment. Bypass capacitors must be of ceramic construction with the shortest possible leads to keep inductance low. Chip capacitors are superior in this respect complementing the increased use of surface mounted integrated devices. Note that both the NE5234D and the automotive grade SA5234D are available and are the surface mount versions of the device.

# Using the NE/SA5234 amplifier

AN1651

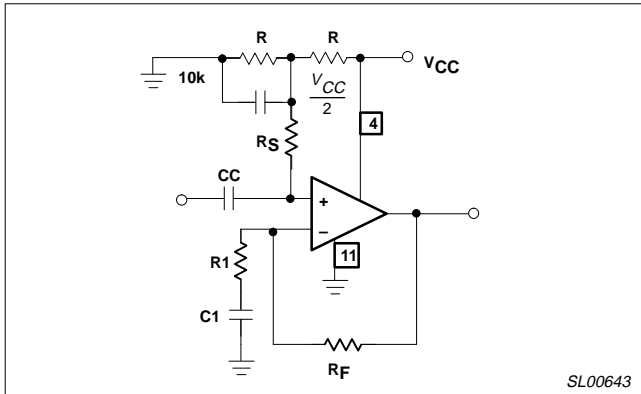

Figure 15. Non-Inverting Biasing

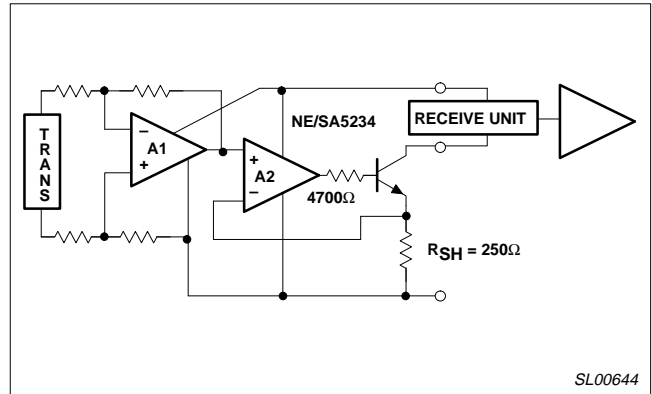

Figure 16. A 4-20mA Current Loop

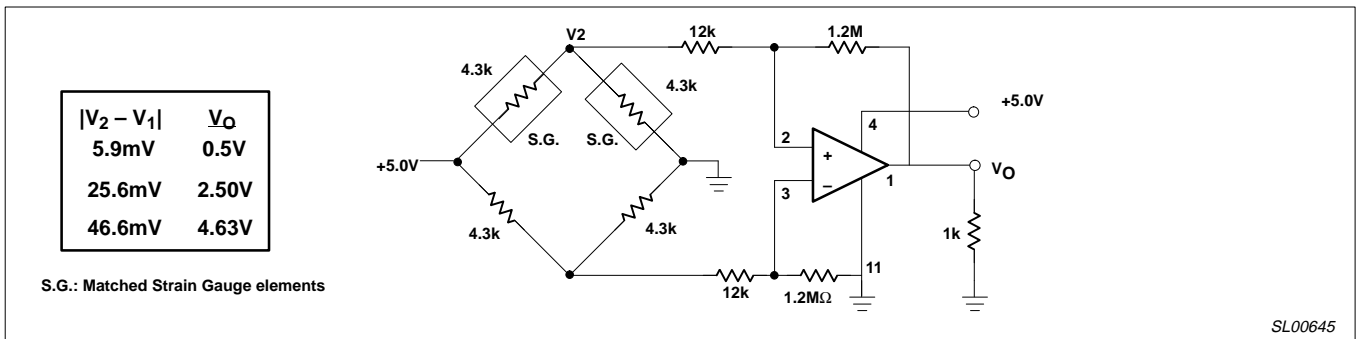

Figure 17. Strain Gauge Amplifier

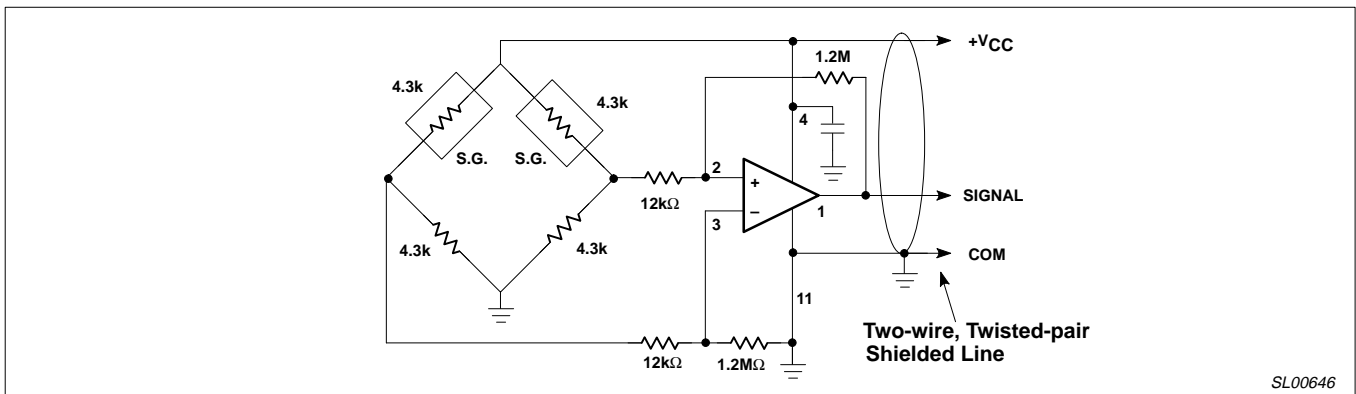

Figure 18. Remote Strain Gauge

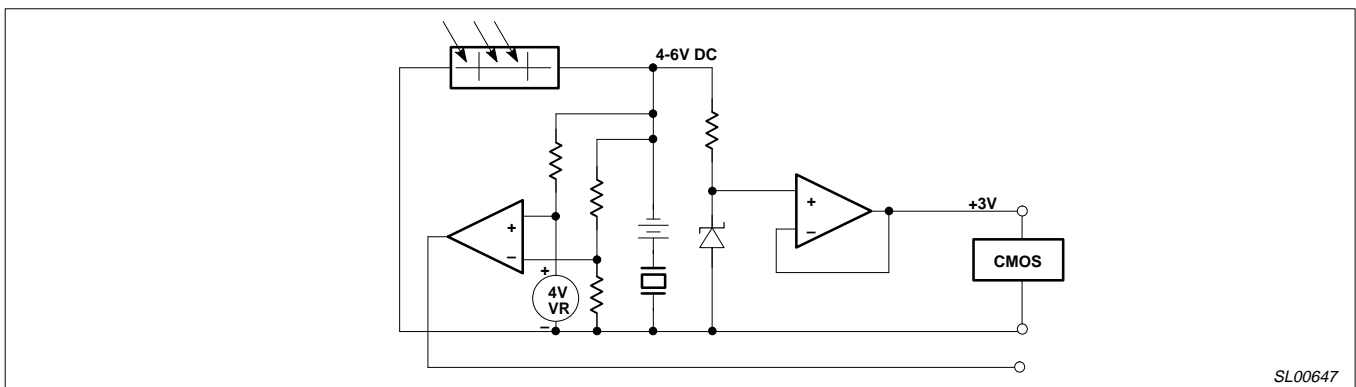

Figure 19. Solar Regulator

# Using the NE/SA5234 amplifier

AN1651

## APPLICATIONS EXAMPLES

### Instrumentation

#### Strain Gauge Bridge Amplifier

The circuit below shows a simple strain gauge circuit with a gain of 100 (40dB) and operated from a single supply. The chart illustrates the transfer function of the circuit for a single order-of-magnitude signal differential range from the bridge beginning with 5mV up to 50mV. The circuit is operated from a single 5V supply, but could equally as well be configured to use a dual balanced supply. It is immediately evident that the wide common-mode output range of the NE5234 is very advantageous in handling this wide range of signals with good linearity due to this feature.

A variation on this particular idea is the remote strain gauge circuit operating from a three wire line, one of which is the shield. This full-differential input circuit has balanced

input resistance to afford good common-mode noise rejection characteristics. Resistors are metal film or deposited carbon. Supply leads must be carefully bypassed close to the NE/SA5234 with ceramic or chip monolithic capacitors to give optimum noise performance. As shown, an auxiliary sub-regulator may be added to improve the overall DC stability of the bridge signal voltage. A regulator capable of providing the necessary few milliamperes at somewhat reduced voltage for the transducer is shown in one of the following examples. This makes use of one of the op amps in the same device package to provide the voltage regulation. Note that the use of multiple op amps within a single package minimizes the possibility of thermal drift and mismatched response from various DC parameters.

Multiple sets of transducers may be constructed from The NE/SA5234 or the NE5234D surface mount device to form a compact and stable instrumentation package. This is useful for transducer applications in

the measurement of pressure, strain, position and temperature, which have similar circuit configurations. First order temperature compensation of the transducers such as semiconductor strain gauges, or resistive units may be achieved by using one of the gauges as a reference device only. It is thermally coupled to the same member as the active gauge, as shown in the example. (Figure 18)

#### **A 4 to 20mA Current Loop**

Some instrumentation installations require the 4-20mA current loop. This addition to the above bridge transducer circuit examples is demonstrated in Figure 16.

This circuit makes use of the remote transducer bridge previously described and adds current loop signaling capability. The voltage-to-current converter consists of an additional op amp from the same NE/SA5234 package combined with a single transistor to

drive the current loop. The sensitivity is actually in mA/V, or transconductance, which is equal to  $1/R_{SH}$ . This sensitivity in this particular example is set to 4mA/V. Thus, with a bridge amplifier having a differential gain of 100, an input of 10mV will produce a 4mA output current and 50mV will produce a 20mA output. Of course the line resistance plus receiver resistance must be within the voltage compliance range of the supply voltage to guarantee linear operation over the total range. A negative supply may be used if it is preferred to have the current loop referenced to ground.

#### DC Regulators and Servos

Closely related to DC and low frequency AC linear transducers are DC regulators and servo circuits. The proliferation of many battery, and solar powered remote instrumentation packages results in a need for adaptable circuits which may readily be made up from existing stock ICs. The examples given here are quite simple, but can be very useful to the designer when economy and size are at a premium.

#### Solar Regulator for 3-Volt CMOS

Working with small instrumentation packages which are to operate from solar photovoltaic cells may bring a need for simple sub-regulators for MOS circuits requiring only a few milliamperes of drain current. Figure 19 shows a simple low voltage regulator making use of the particularly excellent DC characteristics of the NE/SA5234. The regulator becomes an integral part of any functional analog signal processing package such as an environmental data instrumentation unit. The low current drain of the the typical 3V or 5V MOS digital IC allows one sub regulator to serve up to 10 or more such devices. If the instrument package is to be subjected to wide temperature variations, the SA5234 is recommended. A second op amp in the package may serve as a low battery alarm with tone modulator as in radio links, or simple logic level comparator. Overcurrent protection is easily added within the regulator loop to detect short circuit failures and automatically limit the current.

#### DC Servo-amps

Servo control systems for low voltage motor drives require high gain-accuracy and good DC stability for many applications. Applications such as the position control of air flow vanes, servo valves, and optical lenses or apertures, are typical examples. Figure 20 demonstrates one simple DC motor servo application with position control feedback. The motor is a 3V permanent magnet rotor type used in micro-position applications and is adaptable to battery supply environments.

Position information is received from a multi-turn potentiometer to give adequate resolution. The input voltage may be generated from another potentiometer which is remote from the motor drive unit proper, or from a D/A converter output for micro processor controlled systems. The input voltage range is 1.0 to 3.0V and the supply voltage is 4.5V.

# Using the NE/SA5234 amplifier

AN1651

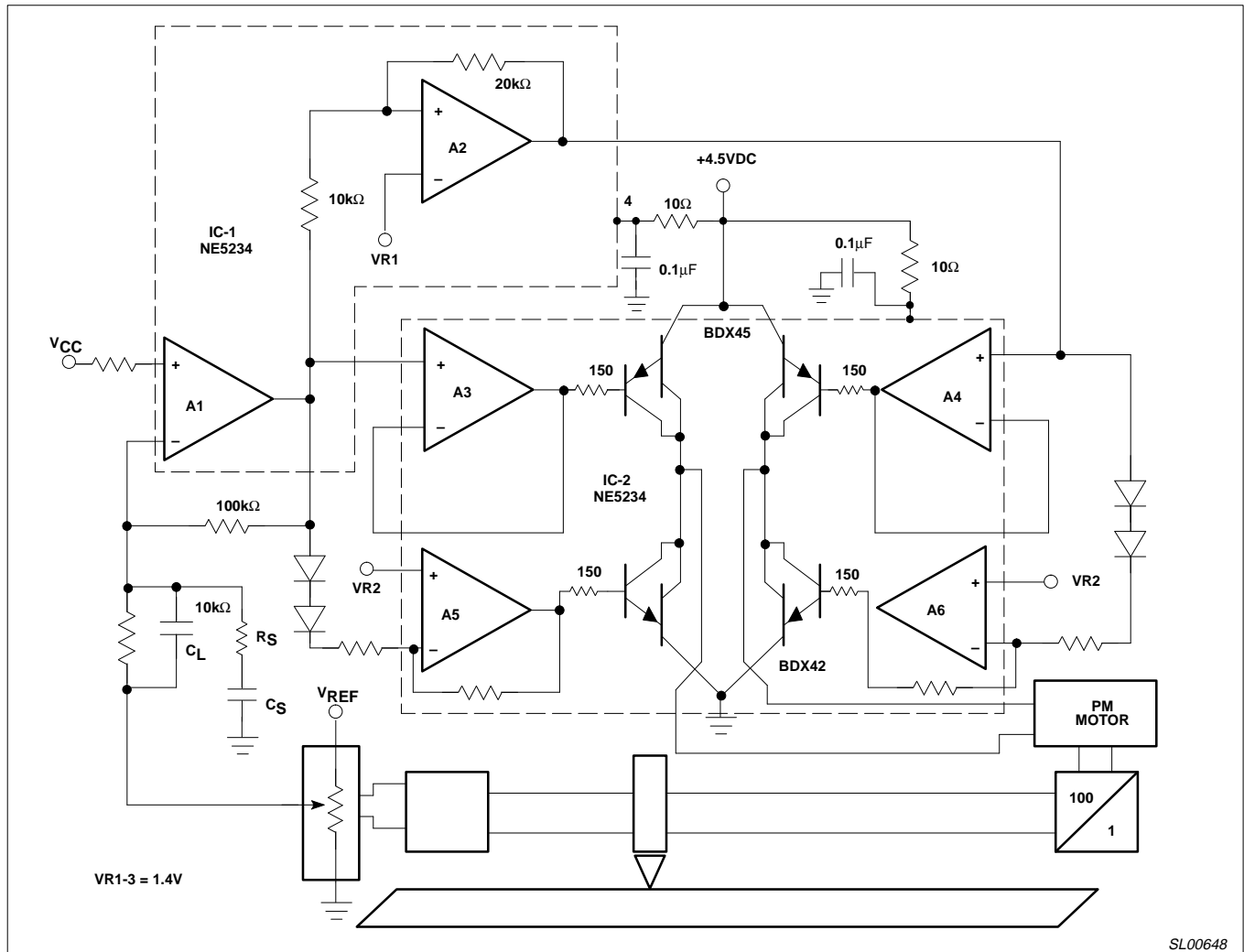

Figure 20. Full Bridge Motor Drive

### Active filters

The NE5234 is easily adapted to use in a variety of active filter applications. Its high open-loop gain and excellent unity gain stability make it ideal for high-pass, band-pass and low-pass configurations operated with low voltage single supplies. Its low output impedance also makes it capable of obtaining low noise operation without resorting to separate high current buffers.

Figure 21a shows the circuit for a VCVS low-pass filter with dual supply biasing and 600Ω output termination. Figure 21b is a band-pass filter with AC coupled gain network for single supply operation.

### Communications and Audio

#### Stereo Bridge Amplifier

Figure 22 shows two NE5234 ICs in a bridge amplifier application. The choice of split supplies allows DC coupling, both from the input signal source and to the load. The gain is set to a nominal 20dB. Either inverting or non-inverting operation is available. The inverting input impedance is chosen as 600Ω in order to match standard

audio impedance lines within a system. The use of two such amplifiers will provide stereo operation to +10dBm for a 600Ω load.

#### Voice Operated Microphone

The processing of voice transmissions for communications channels is generally coupled with the need for keeping the signal-to-noise ratio high and the intelligibility optimized for a given channel bandwidth. In addition, when a circuit is battery operated and portable, the requirement to obtain maximum battery life becomes important. The circuit example shown here is aimed at filling the need for a portable voice operated transmitter, cordless phone, or tape recorder. It utilizes the Philips Semiconductors NE5234 quad op amp in conjunction with the new low-voltage NE578 compandor to create an audio processor capable of operating in just such an environment. Both devices are operational to a low battery voltage of 2.0V. In addition the design further conserves current by automatically shifting the NE578 compandor to standby during the period when no transmissions are being made. Total current consumption at 3.0V is 2.8mA for the NE5234. In the active mode the NE578 draws 1.4mA and this drops to 170μA in the standby mode. This amounts to reducing the supply current demand by approximately 25% in the 'listen mode'.

# Using the NE/SA5234 amplifier

AN1651

Figure 23 shows the VOX audio circuit example. A description of its operation for voice activated transmission follows.

Audio generated by the electret microphone is fed into the non-inverting input of preamp A1 and the signal amplified by 12dB. The biasing is accomplished by the resistive divider which provides a level of half the supply voltage which is connected through a 100k resistor to the non-inverting terminal of A1. This automatically provides ratiometric common mode biasing set at  $V_{CC}/2$  for the device. This level is then transferred directly to the following amplifier, A2, setting its DC operating point. The DC gain of both stage A1 and A2 are unity so the cumulative DC error is not multiplied by stage gain. The peak voice level is approximately  $100mV_{RMS}$  at the input to A1 from the microphone and this is boosted to  $400mV_{RMS}$ . The feedback network gain has a low frequency corner at 160Hz and is flat up to the intersection of the closed loop gain with the open loop gain curve at nearly 500kHz. This would increase the noise bandwidth to an excessive degree unnecessary for voice channel communication. A band limiting network is, therefore, inserted across the feedback resistor to limit response to a nominal 5kHz.

Amplifier stage A2 is used to provide high level audio to the rectifier-filter stage for the rapid generation of a DC control signal for operating the voice activated switch function. Stage A2 gain is set to 20dB in order to allow activation of the voice channel on the rising edge of the first voice syllable. An attack time of 20ms is implemented by adjusting the input charging impedance ( $R_S$ ) between the rectifier and the A2 amplifier output. AC coupling must be used to isolate the DC common-mode voltage of the amplifier from the rectifier/storage capacitor and to allow only audio frequencies to drive the switching circuit. Amplifier A3 provides a high impedance unity gain buffer to allow a very slow decay rate to be applied to the time constant capacitor,  $C_T$ . The output of the storage capacitor reaches approximately 3.2V for a 250ms duration 600Hz burst signal. Diode D1 (1N914) provides a negative clamp action which forces the full peak-to-peak voltage from A2 to charge the storage capacitor. D2 then acts to charge the capacitor to the peak input voltage minus one diode drop, 0.7V. Finally, the buffered

DC control signal is fed to A4 which acts as a threshold comparator with extremely high gain and controlled hysteresis. This provides a positive going signal for releasing the NE578 from its inhibit mode when voice input is present. The NE578 is switched from standby mode when voice input is present. The NE578 is switched from standby mode to the active state by raising the voltage on Pin 8 of the device above 2V. Shutting the audio channel off requires this pin to be driven below 100mV. This demands the extremely wide output voltage swing of the NE5234 in order to reach this near to the negative rail voltage. The voltage threshold of the comparator, A4, is adjustable by use of the sensitivity control,  $R_S$ . It is used to allow the activation level to be raised or lowered depending upon the ambient audio level in the transmitter vicinity.

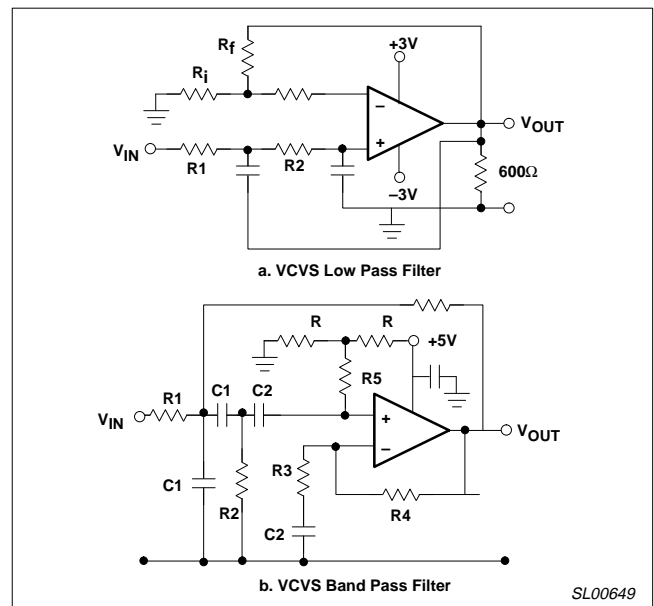

Figure 21. Active Filters

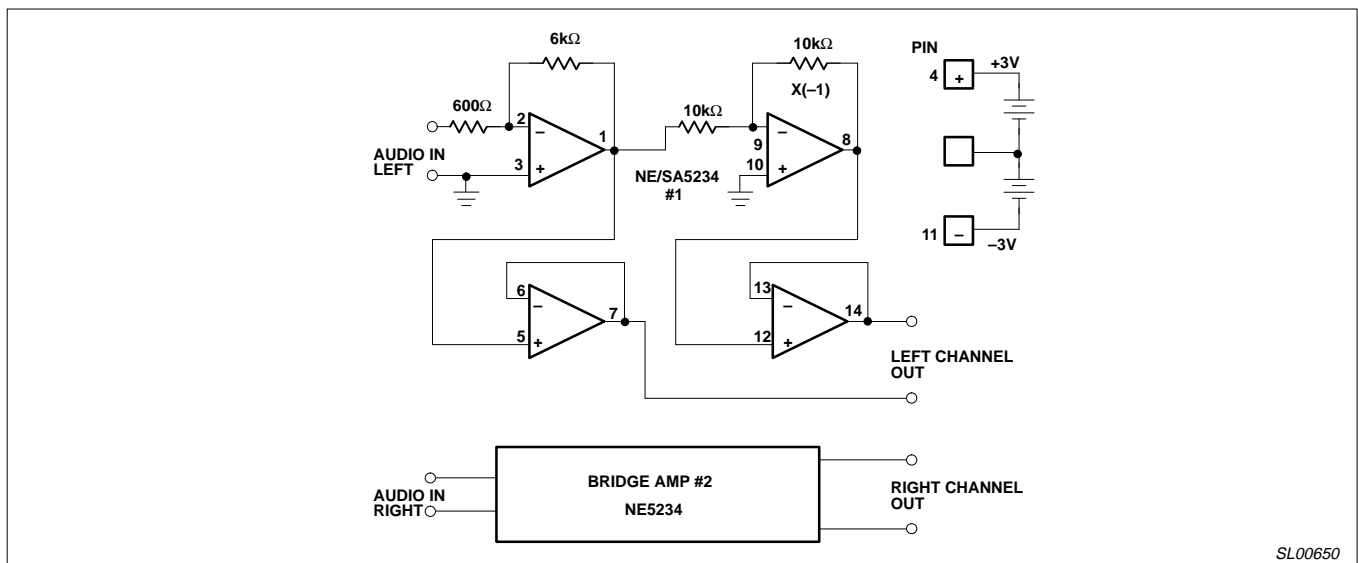

Figure 22. Stereo Bridge Amp

# Using the NE/SA5234 amplifier

AN1651

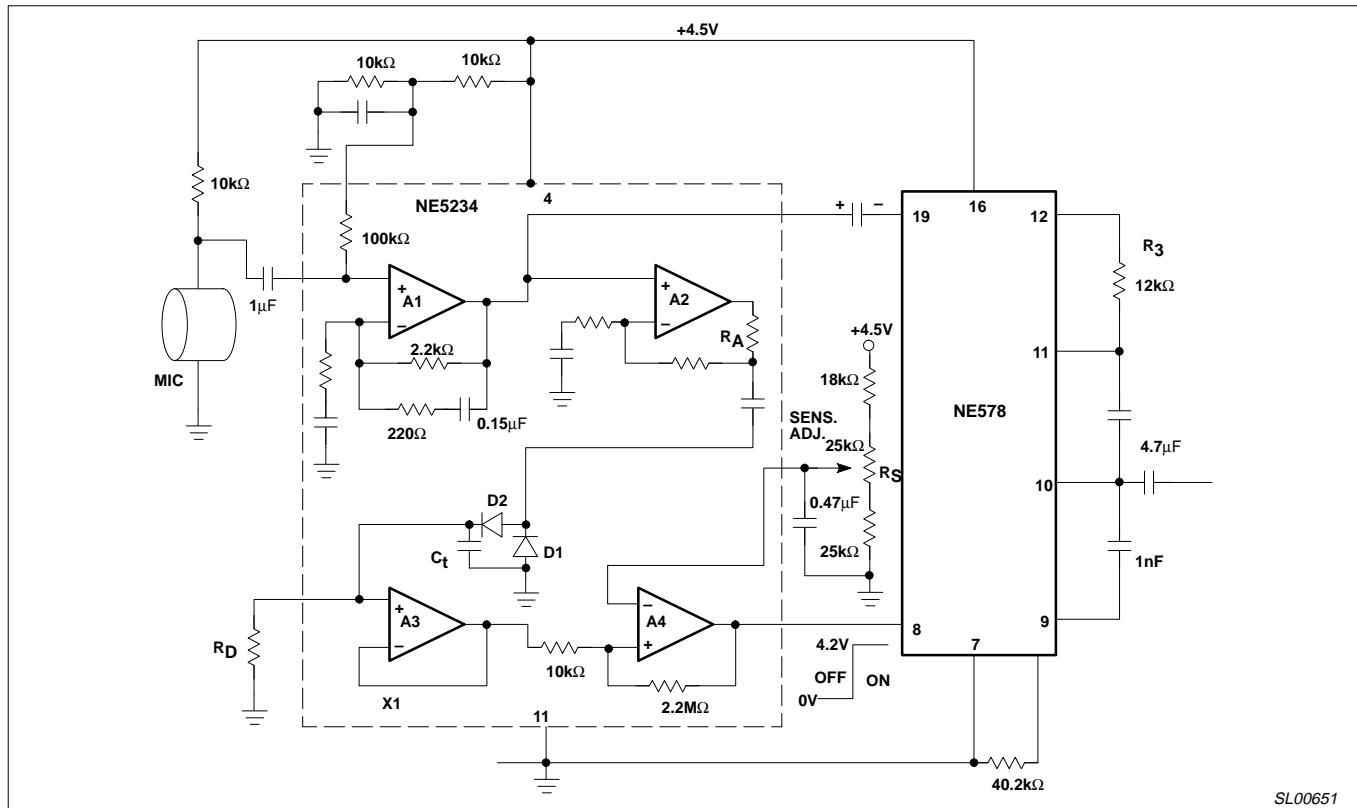

Figure 23. VOX Audio System

Other critical parameters in this type of circuit are the attack and decay times of the RC network which controls the operation of the voice operated switch. Attack time determines how quickly the circuit activates after a quiet period, and the decay time sets how long the transmitter channel stays active between words. It is important to reach an optimum balance between the two time constants in order to allow unbroken transmissions of good quality and no lost syllables. A 100 to 1 attack/decay ratio is used in this particular application and this is primarily set by the value of  $R_A$  and  $R_D$ . A typical delay of two seconds is easily accomplished. Due to extremely high input impedance of the buffer stage A3,  $R_D$  may be in the 1 to 2M $\Omega$  range allowing a reasonable value of storage capacitor to be used.

### The Audio Channel

Audio input from the preamplifier, A1, is fed directly to Pin 14 of the NE578 compandor. Referring to Figure 24, which shows the internal diagram of the device, it can be seen that this is the compressor portion of the NE578. There is the option in this system to operate either in a 2:1 compressor mode or an automatic level control mode, (ALC). The compressor mode simply makes a 2:1 reduction in the amplitude dynamic range of the input signal and brings it up to the chosen nominal 0dB output level which is programmable from 10mV<sub>RMS</sub> to 1V<sub>RMS</sub>. In this particular example it is programmed for a 0dB level of 0.42V<sub>RMS</sub> which is approximately 1V<sub>P-P</sub>. This allows for a standardized output level with good characteristics for FM modulation where peak deviation must be controlled. Figure 25 shows the input-output characteristics of the compressor and ALC.

The compressor also has an attack time determined by capacitor C6 on Pin 11. Attack time is  $10k \cdot C6$ , decay time equals four times this value. An auxiliary amplifier stage is used following the NE578 in order to allow bandwidth and special forms of equalization to be implemented. Note that 2:1 compression in a transmission will enhance the channel dynamic range and may be used with no further processing at the receiver, but feeding the received signal through the complimentary 2:1 expander will achieve even greater enhancement of the recovered audio. The NE578 contains both operations in the same package. Please refer to Philips Semiconductors applications note AN1762 by Alvin K. Wong for complete information on these compandor circuits using the NE578.

### Fiber Optic Receiver for Low Frequency Data (Figure 26)

This application makes use of the NE/SA5234 to detect photo-optic signals from either fiber or air transmitted IR (Infra-red) pulses. The signal is digitally encoded for the highest signal-to-noise ratio. The received signal is sensed by an IR photo diode which has its cathode biased to half the supply voltage (2.5V). The first gain stage is configured as a transimpedance amplifier to allow conversion from the microampere diode current signals to a voltage output of approximately 10mV<sub>0-P</sub>. The second stage provides a gain-of-ten amplifier to raise this signal level to 1V peak amplitude. This stage is directly coupled from the preamplifier stage in order to provide the necessary common-mode voltage of 2.5V. Its gain control network is capacitively coupled to prevent DC gain as is required in single supply configurations. Since this is essentially a pulse gain stage, low frequency gain below the signal repetition rate is not needed. The third stage acts in a limiting amplifier

# Using the NE/SA5234 amplifier

AN1651

configuration and its output is squared to swing approximately 5V, the standard TTL level. Again common-mode biasing is passed along from each of the stages up to the last in order minimize parts and simplify circuit layout. The final stage is a simple buffer amplifier to allow the receiver to drive a low impedance long wire line of 600Ω to 900Ω resistance. Some rise time response adjustment may be required. This is easily achieved following stage three by using  $R_T-C_T$  to limit the rate of change of the signal voltage prior to the buffer. Note that the last stage acts as a zero-crossing detector. This maximizes noise immunity by allowing a transition only after the third stage output voltage has risen above  $2/3V_{CC}$ . Phase inversion may be accomplished, if the logic level signals are polarity reversed, by making stage 3 inverting and AC coupling the input signal with a sufficiently large capacitor to reduce droop. Stage 3 must then be biased by connecting its non-inverting node to bias point 'A'. This provides a 2.5V threshold for the proper

switching operation of the stage. However, care must be taken not allow the network's time constant to become code dependent as to the average low frequency signal components or errors will result in the output signal.

The advantage of this particular circuit is that it has the simplicity of single supply operation along with the capability of a large output swing making it fully TTL compatible

### REFERENCES:

Philips Semiconductors. Linear Data Manual, Volume 2 : Industrial. Sunnyvale: 1988.

Wong, Alvin K. Companding with the NE577 and NE578..Philips Semiconductors Applications Note AN1762 : September 1990.

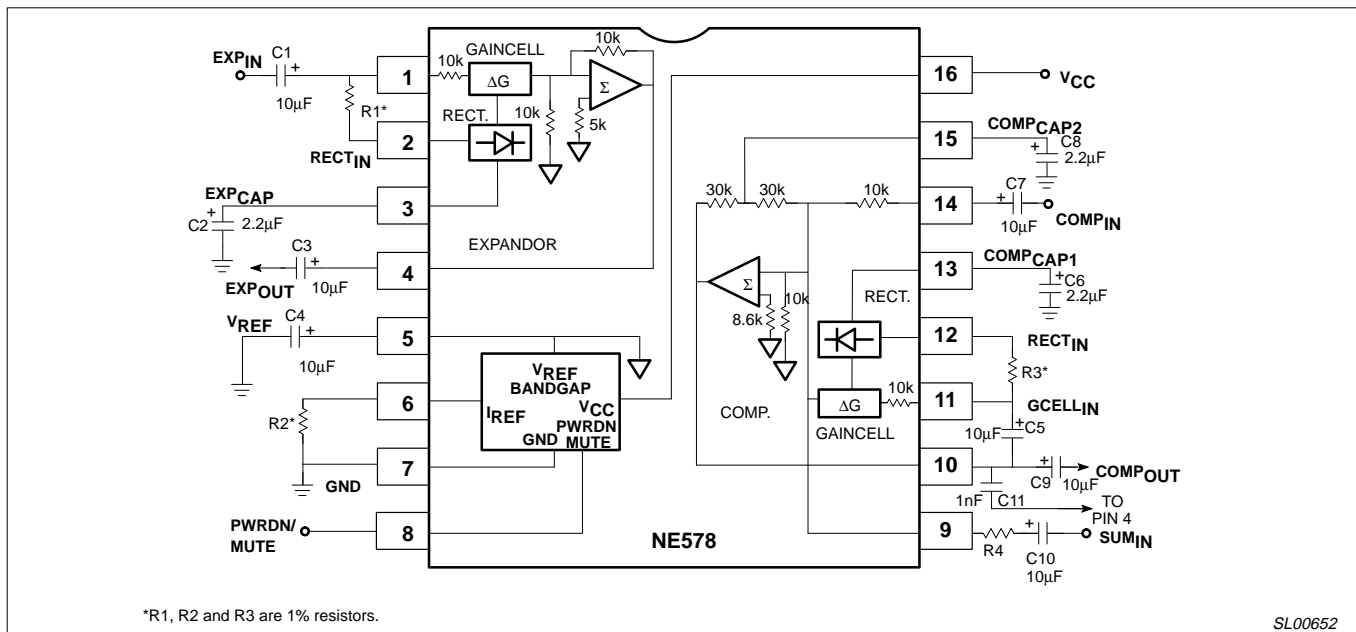

Figure 24. Block Diagram of NE578 Test and Application Circuit

# Using the NE/SA5234 amplifier

AN1651

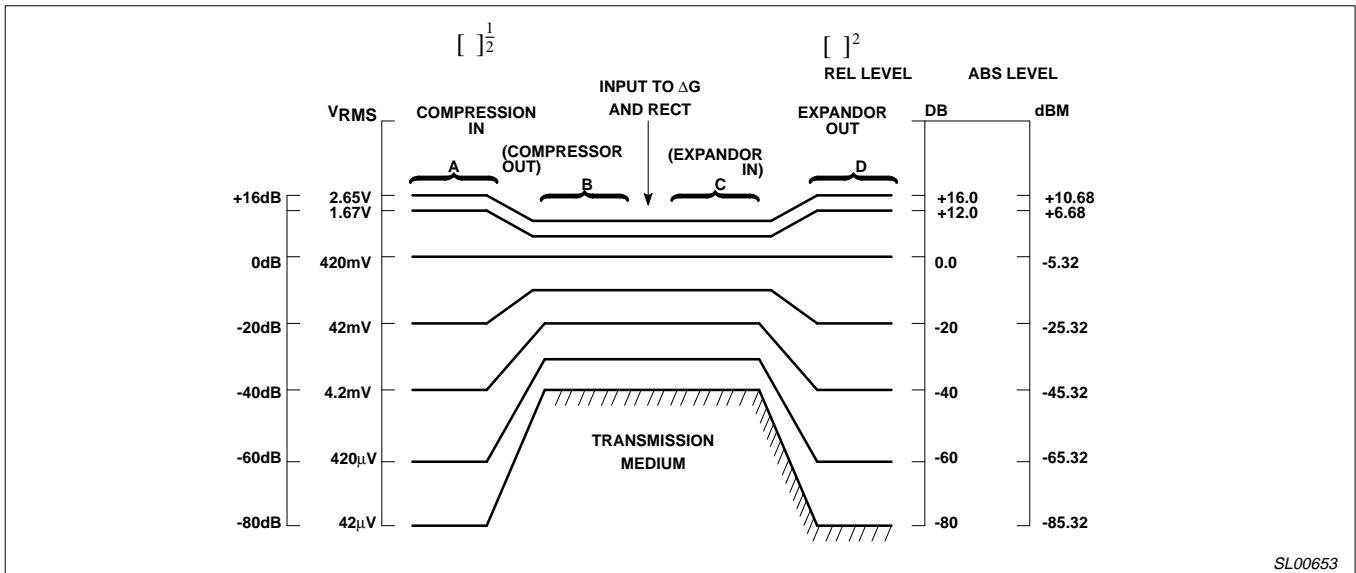

Figure 25. NE570/571/SA571 System Level

SL00653

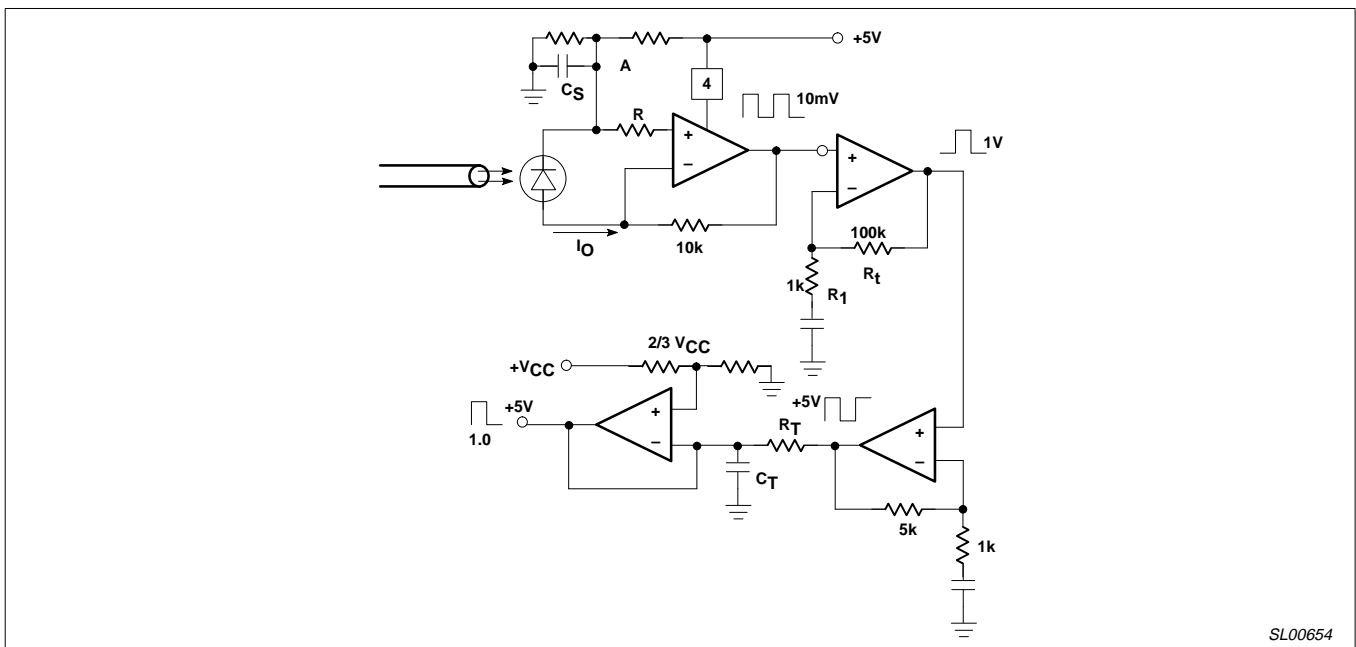

Figure 26. Fiber Optic Data Receiver

SL00654



# Using the NE/SA5234 amplifier

AN1651

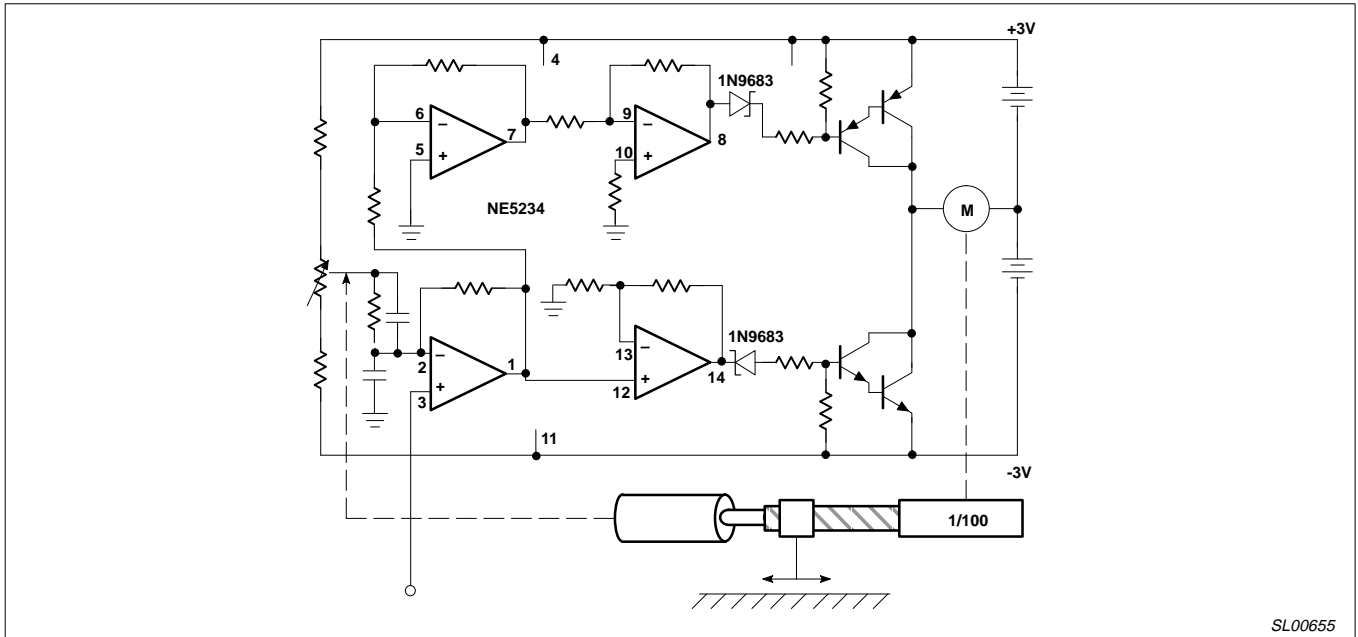

SL00655

Figure 27. Half Bridge Servo

## Free Manuals Download Website

<http://myh66.com>

<http://usermanuals.us>

<http://www.somanuals.com>

<http://www.4manuals.cc>

<http://www.manual-lib.com>

<http://www.404manual.com>

<http://www.luxmanual.com>

<http://aubethermostatmanual.com>

Golf course search by state

<http://golfingnear.com>

Email search by domain

<http://emailbydomain.com>

Auto manuals search

<http://auto.somanuals.com>

TV manuals search

<http://tv.somanuals.com>