

PHILIPS

AS 765C Midi HiFi System

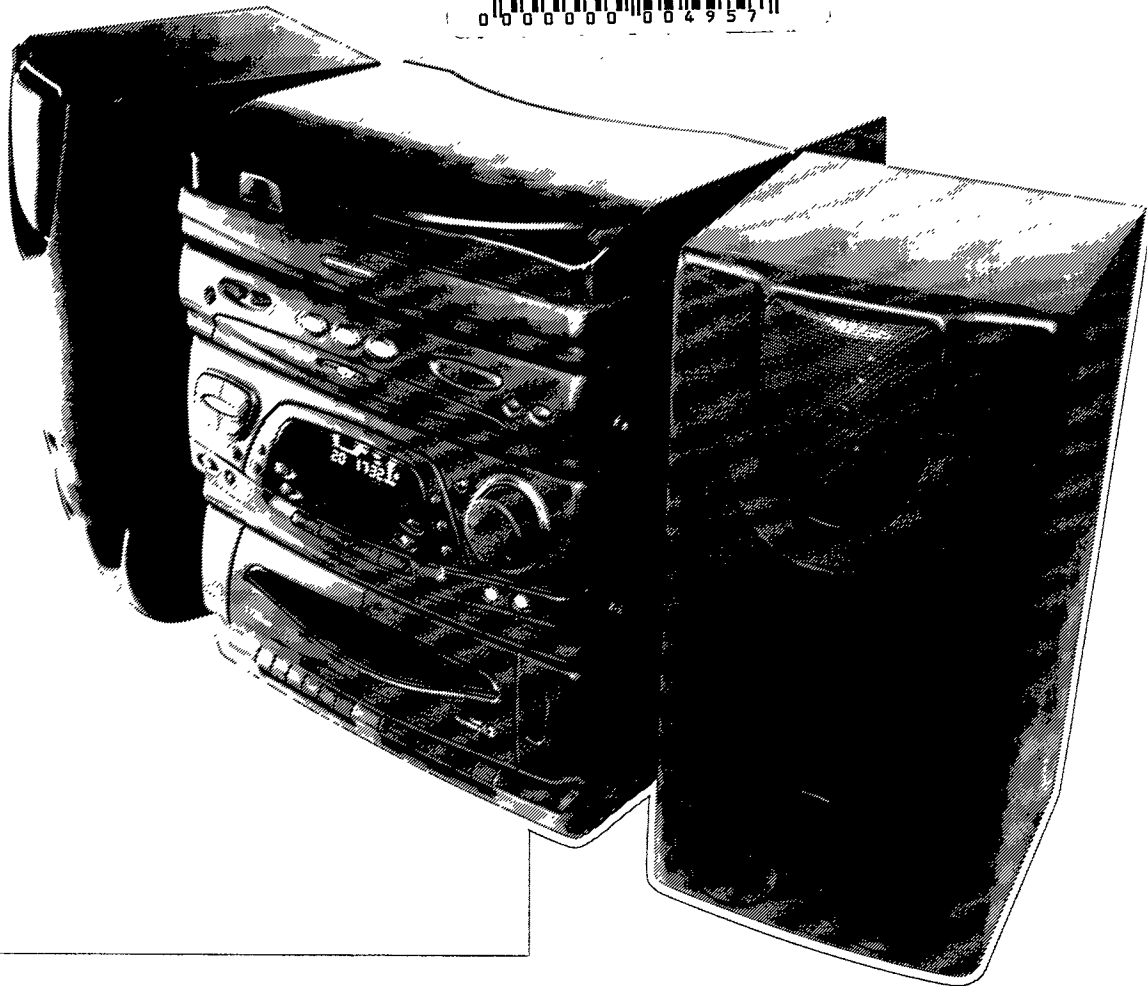

Instructions for use
Mode d'emploi
Instrucciones de manejo
Bedienungsanleitung
Gebruiksaanwijzing
Istruzioni per l'uso
Bruksanvisning
Brugsanvisning
Käyttöohje
Οδηγίες χρήσεως
Manual de utilização



PHILIPS

Important notes for users in the U.K.:

Mains Plug

This apparatus is fitted with an approved 13 Amp plug. To change a fuse in this type of plug proceed as follows:

- Remove fuse cover and fuse.
- Fix new fuse which should be a BS1362 5 A, A.S.T.A. or BSI approved type.
- Refit the fuse cover.

If the fitted plug is not suitable for your socket outlets, it should be cut off and an appropriate plug fitted in its place.

If the mains plug contains a fuse, this should have a value of 5A. If a plug without a fuse is used, the fuse at the distribution board should not be greater than 5A.

Note:

The severed plug must be destroyed to avoid a possible shock hazard should it be inserted into a 13A socket elsewhere.

How to connect a plug

The wires in the mains lead are coloured with the following code: blue = neutral (N), brown = live. (L)

As these colours may not correspond with the colour markings identifying the terminals in your plug, proceed as follows:

- Connect the blue wire to the terminal marked N or coloured black.
- Connect the brown wire to the terminal marked L or coloured red.
- Do not connect either wire to the earth terminal in the plug, marked E (or \perp) or coloured green (or green and yellow).

Before replacing the plug cover, make certain that the cord grip is clamped over the sheath of the lead – not simply over the two wires.

Copyright:

Recording and playback of material may require consent. See Copyright Act 1956 and The Performer's Protection Acts 1958 to 1972.

NORGE

- Typeskilt finnes på apparatens bakside.
- **Observer: Nettbryteren er sekundert innkoplet. Den innebygde nettdelen er derfor ikke frakoplet nettets så lenge apparatet er tilsluttet nettkontakten.**

ITALIA

DICHIARAZIONE DI CONFORMITA'

Si dichiara che l'apparecchio AS765C Philips risponde alle prescrizioni dell' art. 2, comma 1 del D.M. 28 Agosto 1995 n. 548.

Fatto a Eindhoven, il 1/8/1997

Philips Sound & Vision
Philips, Glaslaan 2, SFF 10
5616 JB Eindhoven, The Netherlands

**CLASS 1
LASER PRODUCT**

Index

| | | | | |
|-------------------|---|---|--|------------|
| English | Controls 6-7 Remote Control 7 Operating the System 8 Tuner 9 Cassette Deck 10-11 | Karaoke 11 CD Changer 12-13 Record Player 14 Clock Setting 15 Timer Setting 15 | Maintenance 16 Specifications 16 Troubleshooting Guide 17 | English |
| Français | Opérations Préalables 18-19 Commandes 20-21 Télécommande 21 Utilisation de L'appareil 22 Syntoniseur 23 | Platine Cassette 24-25 Karaoke 25 Changeur de CD 26-27 Platine Tourne-Disque 28 Réglage de L'horloge 29 | Réglage de la Minuterie 29 Entretien 30 Caractéristiques Techniques 30 Remèdes en cas de panne 31 | Français |
| Español | Controles 34-35 Mando a Distancia 35 Funcionamiento del Sistema 36 Sintonizador 37 Reproductor de Casete 38-39 | Karaoke 39 Cambiador de CD 40-41 Tocadiscos 42 Ajuste del Reloj 43 Ajuste del Temporizador 43 | Mantenimiento 44 Especificaciones 44 Solución de Problemas 45 | Español |
| Deutsch | Bedienungselemente 48-49 Fernbedienung 49 Bedienung der Anlage 50 Tuner 51 Cassettendeck 52-53 | Karaoke 53 CD-Wechsler 54-55 Plattenspieler 56 Einstellen der Uhr 57 Einstellen des Timers 57 | Wartung und Pflege 58 Technische Daten 58 Fehlersuche 59 | Deutsch |
| Nederlands | Bedieningstoetsen 62-63 Afstandsbediening 63 Bedienen van het Systeem .64 Tuner 65 Cassettendeck 66-67 | Karaoke 67 CD-Wisselaar 68-69 Platenspeler 70 Instellen van de Klok 71 Instellen van de Timer 71 | Onderhoud 72 Specificaties 72 Verhelpen van Storingen 73 | Nederlands |
| Italiano | Comandi 76-77 Telecomando 77 Uso del Sistema 78 Sintonizzatore 79 Deck Cassetta 80-81 | Karaoke 81 Cambia-CD 82-83 Giradischi 84 Impostazione dell'ora 85 Impostazione del timer 85 | Manutenzione 86 Caratteristiche Tecniche 86 Guida alla ricerca guasti 87 | Italiano |
| Svenska | Kontroller 90-91 Fjärrkontrollen 91 Användning av Systemet 92 Radion 93 Kassettspelaren 94-95 | Karaoke 95 CD Växlaren 96-97 Skivspelaren 98 Klockinställning 99 Timerinställning 99 | Underhåll 100 Tekniska Data 100 Felsökning 101 | Svenska |
| Dansk | Betjeningsknapper 104-105 Fjernbetjeningen 105 Betjening af Anlægget 106 Tuneren 107 Kassettedeck 108-109 | Karaoke 109 CD-Skifteren 110-111 Pladespiller 112 Indstilling af Uret (klokken) 113 Timerindstilling 113 | Vedligeholdelse 114 Specifikationer 114 Fejlsøgning 115 | Dansk |
| Suomi | Painikkeet 118-119 Kauko-ohjain 119 Laitteen Käyttö 120 Viritin 121 Kassettidekki 122-123 | Karaoke 123 CD-Vaihdin 124-125 Levysoitin 126 Kellon Asetus 127 Ajastimen Asetus 127 | Hoito 128 Tekniset Tiedot 128 Tarkistusluettelo 129 | Suomi |
| Ελληνικά | Λειτουργίες 132-133 Τηλεχειριστηρίου 133 Λειτουργία του συστήματος 134 ΡΑΔΙΟΦΩΝΟ 135 | Κασετόφωνο 136-137 Karaoke 137 CD ΠΟΛΛΑΠΛΩΝ 138-139 Πικάπ 140 Ρολόι 141 | Χρονοδιακόπτης 141 Συντήρηση 142 Τεχνικές Προδιαγραφές 142 Επίλυση Προβλημάτων 143 | Ελληνικά |
| Português | Comandos 146-147 Telecomando 147 Funcionamento do Sistema 148 Sintonizador 149 Deck de Cassetes 150-151 | Karaoke 151 Muda Discos 152-153 Gira-Discos 154 Acertar o Relógio 155 Acerto do Temporizador 155 | Manutenção 156 Especificações Técnicas 156 Localização de Avarias 157 | Português |

General Information

- The typeplate is located at the rear of the set.
 - Recording is permissible if copyright or other rights of third parties are not infringed.
- 1 All unnecessary packaging material has been omitted. We have done our utmost to make the packaging easy to separate into three mono-materials:
 - cardboard (box)
 - expandable polystyrene (buffer)
 - polyethylene (bags, protective foam sheet).Please observe the local regulations regarding the disposal of these packaging materials.
 - 2 Your set consists of materials which can be recycled and reused if disassembled by a specialized company. Please follow local regulations on recycling your old set.
 - 3 Do not dispose of dead batteries with your household waste. Dispose of batteries according to local regulations.
 - 4 **Note:** Switching off the standby mode overnight (remove the AC power cord from the wall socket) will save energy.

Safety Information

- Before operating the system, check that the operating voltage indicated on the typeplate (or the voltage indication beside the voltage selector) of your system is identical with the voltage of your local power supply. If not, please consult your dealer. The type plate is located at the rear of your system.
- When the system is switched on, do not move it around.
- Place the system on a solid base (e.g. a cabinet).
- Place the system in a location with adequate ventilation to prevent internal heat build-up in your system.
- Do not expose the system to excessive moisture, rain, sand or heat sources.
- Under no circumstances should you repair the unit yourself, as this will invalidate the warranty!
- If the system is brought directly from a cold to a warm location, or is placed in a very damp room, moisture may condense on the lens of the CD unit inside the system. Should this occur, the CD player will not operate normally. Leave the power on for about one hour with no disc in the unit until normal playback is possible.
- Electrostatic discharge may cause unexpected problems. See whether these problems disappear if you unplug the AC power cord and plug it in again after a few seconds.
- **To disconnect the system from the power supply completely, withdraw the AC power cord from the wall socket.**

Speakers

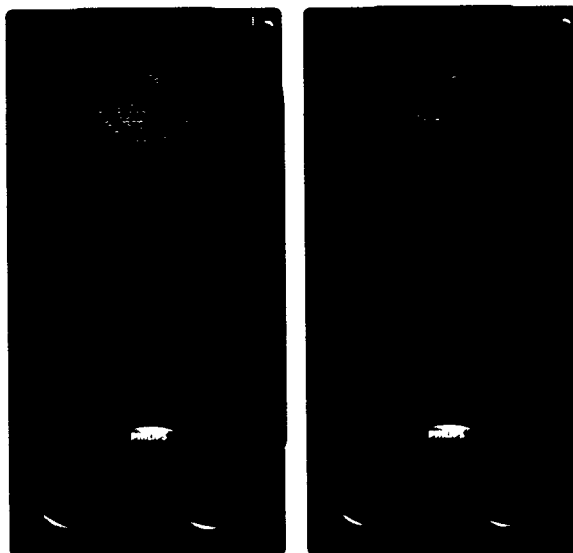

Accessories (Supplied)

- Remote control
- Batteries for remote control
- AM loop antenna
- FM antenna wire
- AC power cord
- 45 rpm single adaptor

Inserting the batteries into the Remote Control

- Insert the batteries (type R6, UM-3 or AA) into the remote control transmitter as shown in the battery compartment.
- To avoid damage from possible battery leakage, remove the batteries if exhausted or unused for extended period. For replacement use type R6, UM-3 or AA batteries.

This product complies with the radio interference requirements of the EU (European Union).

Rear Connection

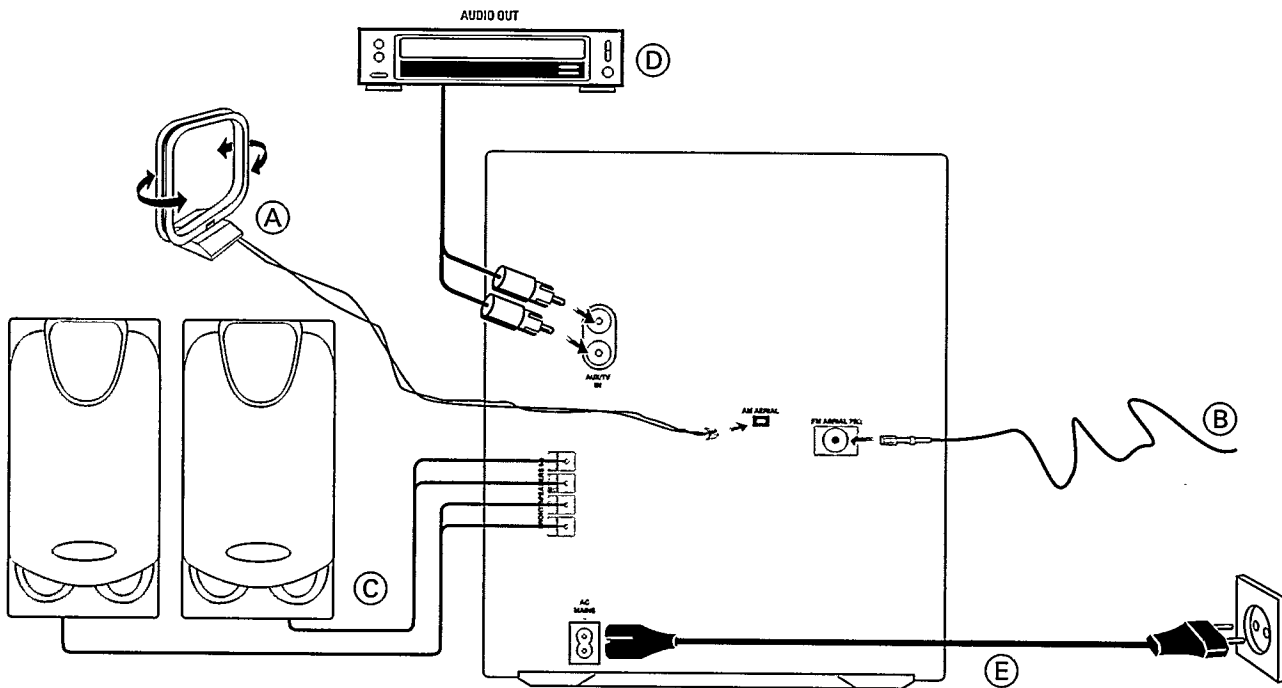

(A) AM Antenna Connection

Connect the supplied loop antenna to the AM AERIAL terminal. Adjust the position of the AM loop antenna for the best reception.

(B) FM Wire Antenna Connection

Connect the supplied FM wire antenna to the FM 75 Ω terminal. Adjust the position of the FM antenna for the best reception.

Outdoor Antenna

For better FM stereo reception connect an outdoor FM antenna to the FM AERIAL 75 Ω terminal using a 75 Ω coaxial wire.

(C) Speaker Connections

- Connect the right speaker to terminal **R**, with the red wire to + and the black wire to -.
- Connect the left speaker to terminal **L**, with the red wire to + and the black wire to -.
- Clip the stripped portion of the speaker wire as shown.

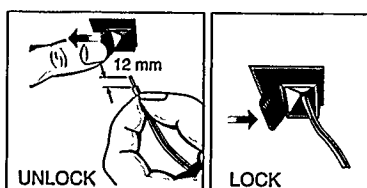

(D) Connecting other equipment to your system

You can connect TV, Laser Disc or VCR audio left and right outputs to the AUX/TV IN terminal at the rear of the system.

(E) AC Power Supply

After all other connections have been made, connect the AC power socket to the set and the AC power plug to the wall outlet.

Controls

English

Front View

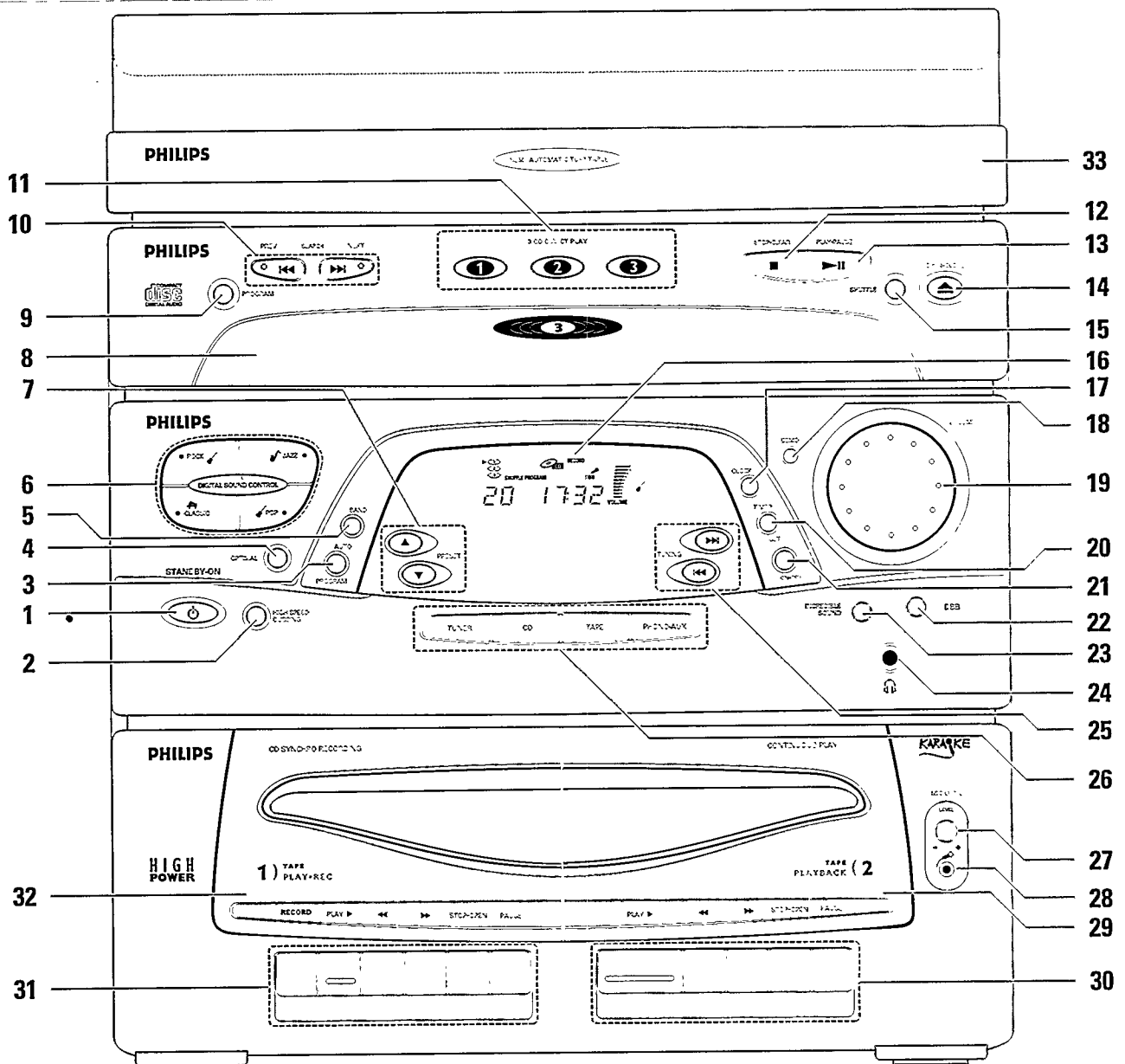

- | | |
|---|--|
| <p>1 STANDBY-ON - to switch the set on or to standby mode.</p> <p>2 HIGH SPEED DUBBING - to dub from TAPE DECK 2 to TAPE DECK 1 at high speed.</p> <p>3 AUTO PROGRAM - to program preset stations automatically or manually.</p> <p>4 OPTIMAL - to select the sound setting that is tuned to the acoustics of the supplied speakers.</p> <p>5 BAND - to select the waveband : FM, MW or LW (<i>not for all versions</i>).</p> <p>6 DIGITAL SOUND CONTROL (DSC) - to select the desired sound effect : JAZZ, ROCK, POP or CLASSIC.</p> | <p>7 PRESET ▲ or ▼ - to select a tuner station in memory. Also use for clock and timer setting.</p> <p>8 CD CAROUSEL TRAY</p> <p>9 PROGRAM - to program CD tracks.</p> <p>10 ◀◀ PREV / NEXT ▶▶ / SEARCH - to skip to the beginning of the current or previous/next track or to search backward/forward.</p> <p>11 3 CD DIRECT PLAY - to select play for each CD tray.</p> <p>12 STOP•CLEAR ■ - to stop CD play or to clear a program.</p> <p>13 PLAY•PAUSE ▶▶ - to start or interrupt CD play.</p> <p>14 OPEN•CLOSE ▲ - to open or close the CD carousel tray.</p> |
|---|--|

- 15 SHUFFLE**
 - to play all the available discs and their tracks in random order.
- 16 DISPLAY**
 - to display the current setting of the set.
- 17 CLOCK**
 - to set the clock.
- 18 DEMO**
 - to display the various features offered by the system.
- 19 VOLUME**
 - to adjust the volume level.
- 20 TIMER SET**
 - to set the timer.
- 21 TIMER ON•OFF**
 - to switch the timer on or off.
- 22 DYNAMIC BASS BOOST (DBB)**
 - to switch on bass boost to enhance bass response or to switch off bass boost.
- 23 INCREDIBLE SOUND**
 - to select the pseudo surround spatial sound effect.
- 24 HEADPHONES**
 - to connect headphones jack.
- 25 TUNING** ◀◀ or ▶▶
 - to tune to tuner stations :
 - ◀◀ : lower frequencies
 - ▶▶ : higher frequencies

Also use for clock and timer setting.
- 26 SOURCE**
 - to select the following :
 - TUNER** : to switch to Tuner mode.
 - CD** : to switch to CD mode.
 - TAPE** : to switch to Tape mode.
 - PHONO•AUX** : to switch to PHONO•AUX mode (for external sources, e.g. TV, Laser Disc or VCR sound).
- 27 MIC LEVEL**
 - to adjust the mixing level for karaoke or microphone recording.
- 28 MICROPHONE**
 - connection for microphone.
- 29 TAPE DECK 2**
- 30 TAPE DECK 2 CASSETTE OPERATION**
 - **PLAY** ▶ : to start playback.
 - ◀◀ : to rewind the cassette.
 - ▶▶ : to fast forward the cassette.
 - **STOP•OPEN** : to stop playback or to open the cassette compartment.
 - **PAUSE** : to interrupt playback.
- 31 TAPE DECK 1 CASSETTE OPERATION**
 - **RECORD** : to start recording.
 - **PLAY** ▶ : to start playback.
 - ◀◀ : to rewind the cassette.
 - ▶▶ : to fast forward the cassette.
 - **STOP•OPEN** : to stop playback or to open the cassette compartment.
 - **PAUSE** : to interrupt playback or recording.
- 32 TAPE DECK 1**
- 33 RECORD PLAYER**

Remote Control Functions

- First select the source you wish to control by pressing one of the source select keys on the remote control (eg. TUNER, CD or TAPE).
- Then select the desired function (PLAY, NEXT, etc.).

Notes:

- Whenever a remote control button is pressed, the source icon on the set display will flicker. This indicates the remote control signal is received by the set.
- For TV/VCR operation, the TV or VCR must use the RC-5 code remote control system.
- Press TV/VCR for more than 1 second to switch on the TV/VCR from the standby mode and also to select PHONO•AUX mode.

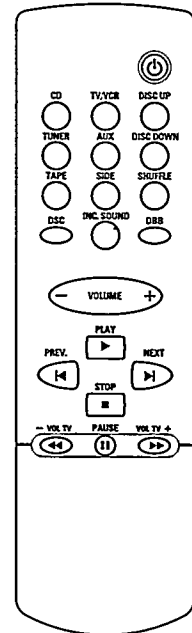

- ⏻ to switch the unit to standby mode.
- CD** to select CD mode.
- TV/VCR** to select TV/VCR and PHONO•AUX mode.
- DISC UP/DOWN** to select desired disc.
- AUX** to select PHONO•AUX mode.
- TUNER** to select TUNER mode.
- TAPE** to select TAPE mode.
- SIDE** not functional for this model.
- SHUFFLE** to play CD tracks at random.
- DBB** to switch on or off dynamic bass boost.
- INC. SOUND** to switch on or off the spatial surround sound effect.
- DSC** to select digital sound control: OPTIMAL, JAZZ, CLASSIC, ROCK or POP.
- VOLUME +/-** to adjust the volume of the system.
- PLAY** ▶ to start play in CD mode.
- STOP** ■ to stop play in CD mode.
- ◀◀ **PREV. / NEXT** ▶▶
 - for TUNER to select a lower/higher tuner preset station.
 - for CD to select previous/next CD track.
 - for TV/VCR to select previous/next channel.
- PAUSE** || to interrupt play in CD mode.
- ◀◀ / ▶▶
 - for TUNER to tune to a lower/higher frequency.
 - for CD to search a particular passage.
- TV VOLUME +/-** to adjust the TV (RC 5 code) volume.

Operating the System

English

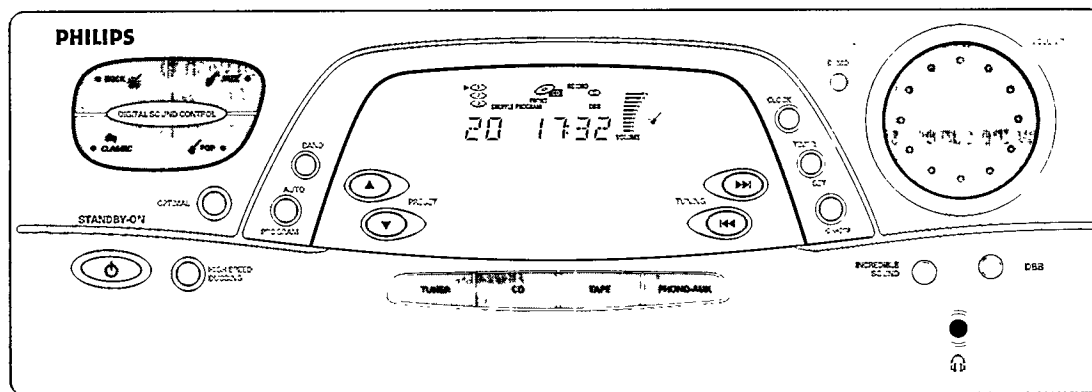

Demo mode

The system has a demonstration mode that shows the various features offered by the system. Whenever the system is switched on from the wall socket, the demonstration mode will start automatically.

To stop demonstration mode

- Press **DEMO**, **STANDBY-ON**, **TUNER**, **CD**, **TAPE** or **PHONO•AUX** button on the system (or **⏻**, **TUNER**, **CD**, **TAPE** or **AUX** on remote control) to stop the demonstration mode.

To switch on demonstration mode

- Press **DEMO**.
→ The display will show "WELCOME TO THE AUDIO WORLD", then a demonstration of the various features will follow.

Important:

Before you begin operating the system, complete the preparation procedures.

Switching the system ON

- Press **STANDBY-ON**, **TUNER**, **CD**, **TAPE** or **PHONO•AUX** (or **TUNER**, **CD**, **TAPE** or **AUX** on the remote control).

Switching the system to standby mode

- Press **STANDBY-ON** again (or **⏻** on the remote control).

Selecting the Sound Source

- Press one of the source buttons to select either **TUNER**, **CD**, **TAPE** or **PHONO•AUX** (or **TUNER**, **CD**, **TAPE** or **AUX** on the remote control).
→ The display indicates the selected sound source.

You can also select the sound source directly by selecting the respective **PLAY** button for CD mode or the **PRESET**, **BAND** or **TUNING** button for TUNER mode.

Note:

For external sound source, make sure that you have connected the audio left and right outputs terminals of the external equipment (TV, VCR or Laser Disc player) to the **AUX/TV IN** terminals at the rear of the set.





Volume Adjustment

Turn **VOLUME** right or left (or press **VOLUME +** or **-** on the remote control) to increase or decrease the sound level.

For Personal Listening

Connect the headphones to the  socket. The speakers will be muted.

Digital Sound Control (DSC)

- To enjoy a special sound effect, press **JAZZ** (), **CLASSIC** (), **ROCK** () or **POP** ().

Optimal Sound

- Press **OPTIMAL** to hear the sound setting that is tuned to the acoustics of the supplied speakers.

Dynamic Bass Boost (DBB)

- Press **DBB** to enhance the bass response.
→ The **DBB** flag lights up.

The button lights up when the **DBB** feature is switched on.

Incredible Sound

- In addition to all other sound settings, you can activate the spatial surround sound feature by pressing **INCREDIBLE SOUND**.

→ This creates a phenomenal surround sound effect even if the speakers are positioned close to the system. The sound becomes "incredibly" spatial.

The button lights up when the incredible sound feature is switched on.

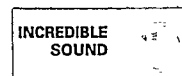

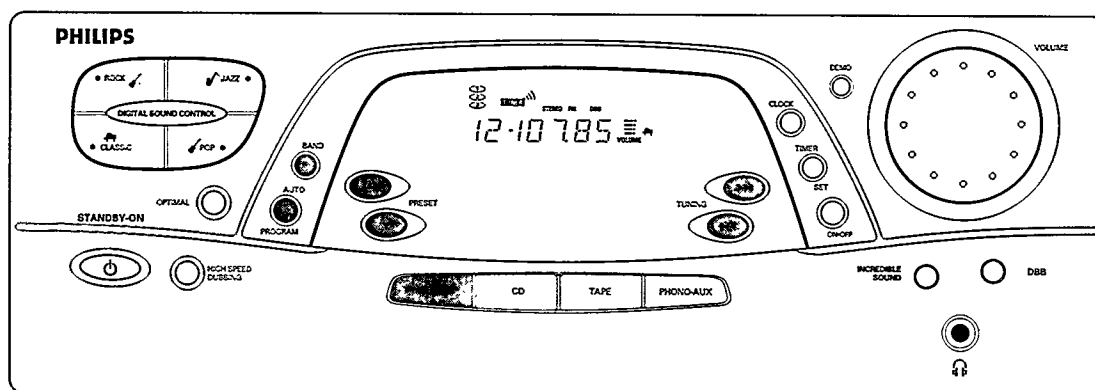

Tuning to radio stations

- 1 Press **TUNER**.
- 2 Press **BAND** to select the desired waveband : FM, MW or LW (not for all versions).
- 3 Press **TUNING** |◀◀ or ▶▶| for more than one second.
 - The display will show 'SEARCH' until a station with sufficient signal strength is found.
 - Repeat this procedure until the desired station is reached.
 - To tune to a weak station, briefly press **TUNING** |◀◀ or ▶▶| until the display shows the right frequency and/or when the best reception has been obtained.

Storing Preset Stations

You can store up to 20 stations in the memory. When a preset station is selected, the preset number appears next to the frequency on the display.

Automatic programming

- 1 Press **BAND** to select the desired waveband : FM, MW or LW (not for all versions).
- 2 Press **AUTO PROGRAM** for more than one second to start the automatic programming.
 - PROGRAM flashes and 'AUTO' is displayed.
 - Every available station will be stored automatically. The frequency and preset number will be displayed briefly.
 - It will stop searching when all the available stations are stored or the memory for 20 preset stations is used.
- You can cancel the automatic programming by pressing **AUTO PROGRAM**, **TUNING** |◀◀ or ▶▶|, **PRESET** ▼ or ▲ or **BAND**.

Note:

If you want to reserve a section of preset numbers, for example preset number 1 - 9, select preset 10 before starting automatic programming. Now only the preset numbers 10 to 20 will be programmed.

Manual programming

- 1 Press **AUTO PROGRAM** for less than one second.
 - PROGRAM flashes on the display.
- 2 Press **BAND** to select the desired waveband : FM, MW or LW (not for all versions).
- 3 Press **TUNING** |◀◀ or ▶▶| to tune to the desired frequency.
- 4 Press **PRESET** ▼ or ▲ to select a preset number.
- 5 Press **AUTO PROGRAM** again.
 - PROGRAM disappears, and the station is stored.
- Repeat the above procedure to store other preset stations.

Tuning to Preset Stations

- Press **PRESET** ▼ or ▲ (or |◀ PREV or NEXT ▶| on the remote control) to select the desired preset number.
 - The preset number, frequency and waveband appear on the display.

Cassette Deck

English

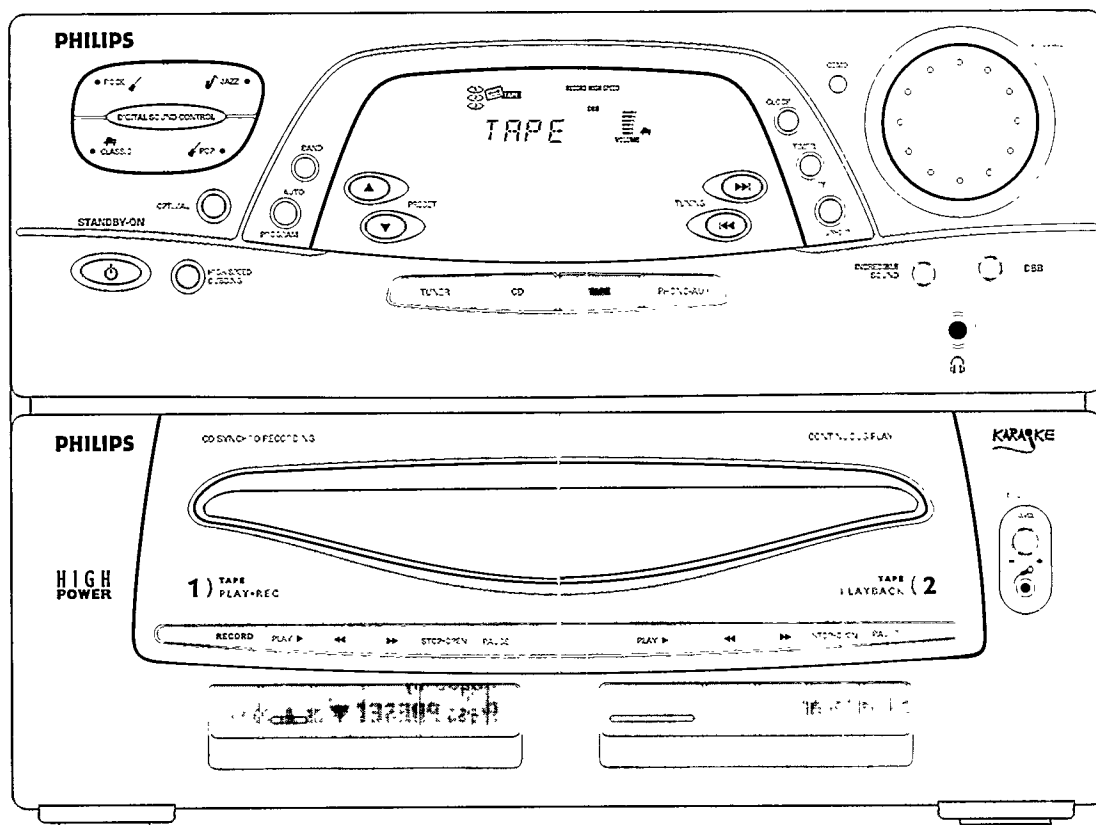

Loading a cassette

- Press **STOP•OPEN**.
- The cassette compartment door opens.
- Load the cassette with the open side downward and the full spool to the left.
- Close the cassette compartment door.

Tape Playback

- 1 Press **TAPE**.
- 2 Load the cassette into a **cassette deck**.
- 3 Press **PLAY ►** to start playback.
- 4 Press **STOP•OPEN** to end playback.

Fast Forward/Rewinding

- 1 You can rewind or fast forward the cassette by pressing **◀◀** or **▶▶**.
- 2 Press **STOP•OPEN** to stop fast forwarding or rewinding.

Note:

It is possible to fast forward or rewind a cassette when the set is in another source mode (e.g. TUNER, CD or PHONO•AUX mode).

Continuous playback of two cassettes

- 1 Press **TAPE**.
- 2 Load the cassettes in **tape deck 1** and **tape deck 2**.
- 3 Press **PLAY ►** on **tape deck 2**.
- 4 Press **PAUSE** on **tape deck 1**.
- 5 Press **PLAY ►** on **tape deck 1**.
→ Playback will begin with **tape deck 2** and will continue with **tape deck 1** when **tape deck 2** ends.
- 6 Press **STOP•OPEN** if you want to stop playback before the end of the cassette in **tape deck 1** or **tape deck 2**.

Recording (TAPE DECK 1)

- 1 Press **TUNER, CD** or **PHONO•AUX**.
- 2 Load a blank cassette into **tape deck 1**.
- 3 Press **RECORD** on **tape deck 1** to start recording.
→ The **RECORD** flag starts flashing.
- 4 Press **STOP•OPEN** on **tape deck 1** to stop recording.

Note:

During recording, it is not possible to listen to another sound source.

Dubbing cassettes (from TAPE DECK 2 to TAPE DECK 1)

- 1 Load the pre-recorded cassette into **tape deck 2** and a blank cassette into **tape deck 1**.
 - Make sure that both cassettes have their full spools to the left.
- For high speed recording, press **HIGH SPEED DUBBING**.
 - HIGH SPEED appears on the display.
- 2 Press **PAUSE** on **tape deck 1**.
- 3 Press **RECORD** on **tape deck 1**.
 - RECORD appears on the display.
- 4 Press **PLAY ►** on **tape deck 2**.
 - Recording will start automatically.
- 5 Press **STOP•OPEN** on **tape deck 1** and **tape deck 2** to stop dubbing.

**Notes:**

- At the end of side A, flip the cassettes to side B and repeat the procedure.
- Dubbing of cassettes is only possible in the Tape mode. To ensure good dubbing, use tapes of the same length.
- During high speed dubbing in Tape mode, the sound is reduced to a low volume.

General Information

- For recording, use only a cassette of IEC type I (normal cassette).
- The tape in the cassette is secured at both ends with leader tape. At the beginning and end of a cassette, nothing will be recorded for six to seven seconds.
- The recording level is set automatically, regardless of the position of VOLUME.
- Check and tighten slack tape with a pencil before use. Slack tape may get jammed or may burst in the mechanism.
- To prevent accidental recording, break out the tab on the left shoulder of the cassette side. To re-record the cassette, cover each hole with cellophane tape.

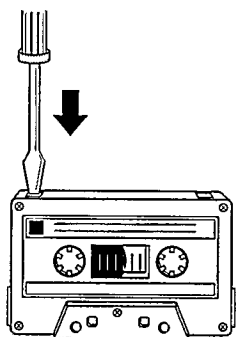

- C-120 tape is extremely thin and may be easily deformed or damaged. It is not recommended for use in this unit.
- Store the cassettes at room temperature and do not put them too close to a magnetic field (for example, transformers, TVs or speakers).

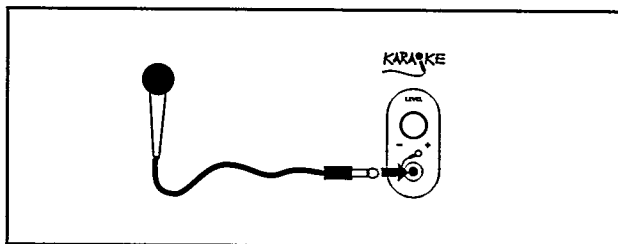
Karaoke**Microphone mixing**

- 1 Connect the microphone to the mic socket.
- 2 Press **TUNER, CD, TAPE** or **PHONO•AUX**.
- 3 Play the selected source.
- 4 Adjust the volume with **VOLUME** control.
- 5 Adjust the **MIC LEVEL** control to the mixing level that you want.
- 6 Start singing or talking through the microphone.

Note:

- To prevent acoustics feedback (for example, a loud howling sound), adjust the MIC LEVEL control to the minimum before you plug in the microphone.

Recording the mixed sound

During microphone mixing, you can record the mixed sound on a cassette in TAPE DECK 1.

- 1 Load a blank cassette in **tape deck 1**.
- 2 Press **RECORD**.

Note:

- If you do not intend to record via the microphone, unplug the microphone to avoid accidental mixing with other recording source.

CD Changer

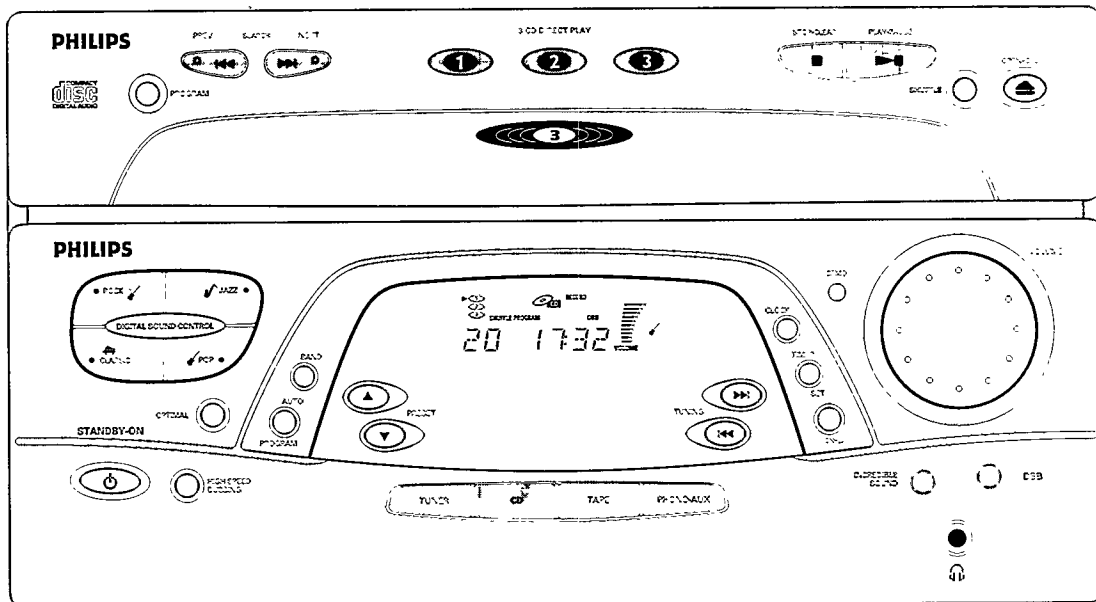

Warning!

- 1) This set is designed for conventional CDs. Do not use any accessories like disc stabilizer rings or CD treatment sheets, etc, which may damage the CD mechanism.
- 2) Do not load more than one disc into each tray.
- 3) When the CD changer is loaded with CD(s), do not turn over or shake the unit as this may jam the changer mechanism.

You can load up to three discs in the CD changer for continuous play without interruption. In addition to the conventional 12-cm disc, 8-cm discs can also be used without an adaptor.

Loading the CD Changer

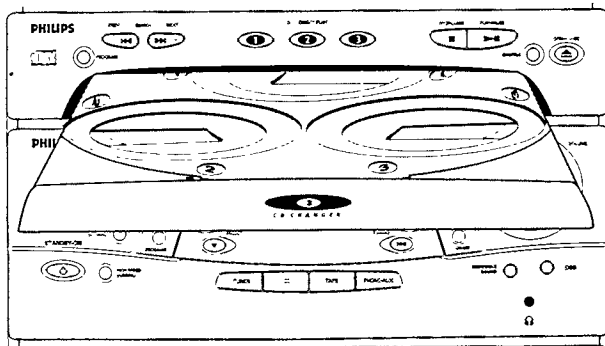

- 1 Press **CD**.
- 2 Press **OPEN•CLOSE ▲**.
→ The CD compartment slides out.
- 3 Load a disc with the **printed side up** in the right tray.
 - You can load another disc in the left tray.
 - To load the third disc, press the corresponding **3 CD DIRECT PLAY** button of the empty tray.
→ The CD changer carousel will rotate until the empty tray is at the right hand side and is ready for loading.
→ Playback will always start with the outer right disc tray.

- 4 Press **OPEN•CLOSE ▲** to close the CD compartment.
→ The total number of tracks and playing time of the last selected disc appear on the display.

The following display indications will help you to know whether the disc trays are empty or loaded.

- 1 – indicates disc tray 1 is empty.
- ② – indicates disc tray 2 is loaded with a disc.
- ▶③ – indicates disc tray 3 is loaded and selected disc tray.

Playing a Disc

- 1 Press **PLAY•PAUSE ▶||** (or **PLAY ▶** on the remote control) to start playback.
→ The disc tray, track number and elapsed playing time of the current track appear on the display.
 - To interrupt play, press **PLAY•PAUSE ▶||** (or **PAUSE ||** on the remote control).
→ The playing time flashes.
 - To resume play, press **PLAY•PAUSE ▶||** again (or **PLAY ▶** on the remote control).
- 2 To stop play, press **STOP•CLEAR ■** (or **STOP ■** on the remote control).

Note:

If no action is performed during playback, all the available discs will play once and then stop. When the CD has stopped playing, the set will switch to the standby mode after 15 minutes if no button is pressed.

When the CD tray is closed, you can also play a CD directly by pressing the **3 CD DIRECT PLAY (1 - 3)** (or **DISC UP/DOWN** on the remote control) buttons. The CD player will stop at the end of playback of the selected disc.

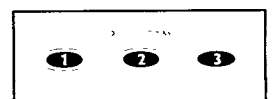

Selecting a desired track

Selecting a desired track at the stop mode

- 1 Press **◀◀ PREV** or **NEXT ▶▶** (**◀ PREV** or **NEXT ▶** on the remote control) until the desired track appears on the display.
- 2 Press **PLAY•PAUSE ▶▶II** (or **PLAY ▶** on the remote control) to start playback.
 - The selected track number and elapsed playing time appear on the display.

Selecting a desired track during play mode

- 1 Press **◀◀ PREV** or **NEXT ▶▶** (**◀ PREV** or **NEXT ▶** on the remote control) until the desired track appears on the display.
 - The selected track number and elapsed playing time appear on the display.
- If you press **◀◀ PREV** once it will skip to the beginning of the current track and play the track again.

Searching for a particular passage during play

- Press and hold **SEARCH ◀◀** or **▶▶** (**◀◀** or **▶▶** on the remote control) until the desired passage is located. During the search, the sound is played faster than normal at a reduced volume. Play returns to normal when **SEARCH ◀◀** or **▶▶** is released.

Shuffle

SHUFFLE – playing all the available discs and their tracks in random order. It can also be used during program mode.

To shuffle all the discs and tracks

- 1 Press **SHUFFLE** (or **SHUFFLE** on the remote control).
 - "SHUFFLE" flashes briefly on the display.
 - The SHUFFLE flag, the disc and the track selected at random appear on the display.
- The discs and the tracks will now be played in random order until you press **STOP•CLEAR ■**.
- 2 Press **SHUFFLE** again to resume normal play.
 - The SHUFFLE flag disappears from the display.

Programming Tracks

Programming tracks of a loaded CD is possible when CD playback is stopped. Reviewing of a program is only possible in stop mode. The display will indicate the total tracks stored in the program. Up to 40 tracks can be stored in the memory in any order. When 40 tracks are stored and you attempt to store another track, the display will show "PROGRAM FULL".

- 1 Load the desired discs in the disc trays.
- 2 Press **PROGRAM** to start programming.
 - The PROGRAM flag flashes on the display.
- 3 Press the desired disc button to select the disc.
- 4 Press **◀◀ PREV** or **NEXT ▶▶** to select the desired track.
- 5 Press **PROGRAM** to store the track.
- Repeat steps 3 to 5 to store other discs and tracks.

- 6 Press **STOP•CLEAR ■** once to end programming mode.
 - The total number of tracks programmed and total playing time appear on the display.

Playing the program

- 1 Press **PLAY•PAUSE ▶▶II** (or **PLAY ▶** on the remote control) to start program playback.
 - The track number and elapsed playing time of the current track appear on the display.
- 2 Press **STOP•CLEAR ■** (or **STOP ■** on the remote control) to stop program playback.

Note:

If you press any of the 3 CD DIRECT PLAY buttons, the set will play the selected disc, the stored program will be ignored temporarily. The PROGRAM flag will also temporarily disappear from the display and then reappear when the playback for the selected disc ends.

Reviewing the program

Reviewing the program is only possible when CD playback is stopped.

- Press **◀◀ PREV** or **NEXT ▶▶** repeatedly to review the programmed tracks.

Erasing the program (when playback is stopped)

- Press **STOP•CLEAR ■**.
 - "PROGRAM CLEARED" appears on the display.

Note:

The program is also erased when the set is disconnected from the power supply. If the CD carousel is opened, only the outer two trays will be erased and the display will show "CLEARED".

CD Recording

During CD recording,

- It is not advisable to fast forward/rewind your cassette in TAPE DECK 2.
- It is not possible to listen to another sound source.

CD Recording

- 1 Load a blank cassette (full spool to the left) into **tape deck 1**.
- 2 Press **CD**.
- 3 Load a disc into the disc tray.
- 4 Press **◀◀ PREV** or **NEXT ▶▶** to select the desired track. If desired, you can program the tracks in the order you want them to be recorded (see Programming Tracks).
- 5 Press **RECORD** on **tape deck 1** to start recording.
 - The RECORD flag flashes on the display.
 - CD starts playing.
- 6 Press **STOP•CLEAR ■** on **CD** and **STOP•OPEN** on **tape deck 1** to stop recording.

Record Player

English

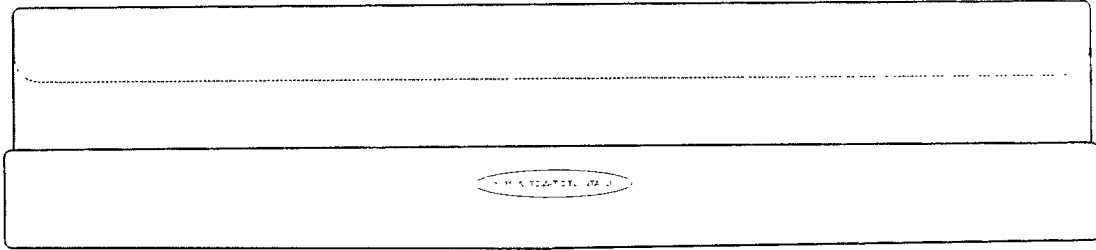

Record Player Controls

- ① Transport safety screws.
- ② Pick up arm lever for raising and lowering the pick up arm.
- ③ RPM selector for selecting the appropriate speed at 33 or 45 rpm.
- ④ Pick up arm lever clamp.

Note:

Preparation for use

Fully tighten both record player transport safety screws. Screw in clockwise direction.

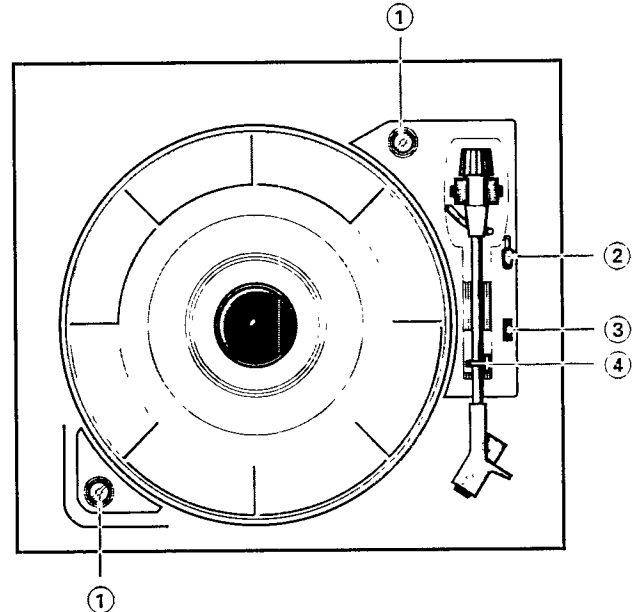
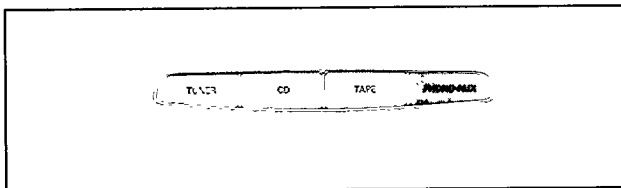

Record Player Operation

- 1 Press **PHONO•AUX**.
- 2 Place a record on the turntable.
- 3 Remove the stylus guard by gently pulling it forward.
- 4 Set the appropriate speed - 33 or 45 - on the rpm selector.
- 5 Release the pickup arm from its clamp.
- 6 Set the lever to **∇** (UP).
- 7 Move the pickup arm inwards. This starts the record player. Then position the arm above the desired track or passage on the record.
- 8 Move the lever carefully to the **∇** (DOWN) position. Playback of the record begins.
- 9 At the end of the record the pickup arm returns to its support and the record player is automatically switched off.
- 10 Record playback can be stopped at any given time by setting the lever to the **∇** (UP) position and then moving the pickup arm outwards.

When the pickup arm reaches the support, the turntable will stop. The lever can now be set to the **∇** (DOWN) position, the arm secured and the stylus guard replaced.

Notes:

1. At first it is possible that the pickup arm will not return to its support. If this happens, move the pickup arm by hand - gently! - to the centre of the record. Once the mechanism has been actuated in this way, it will subsequently operate automatically.
2. To change needle gently pull it down and take it out (see figure). Replace the needle with same model by pushing to the original place. The "click" indicates that the new needle is fixed.

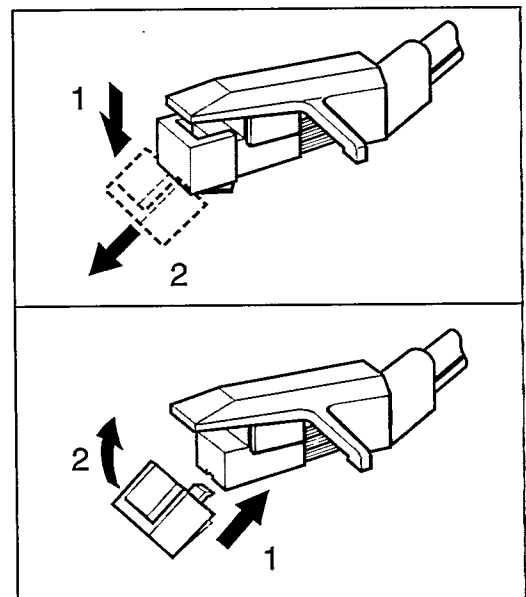

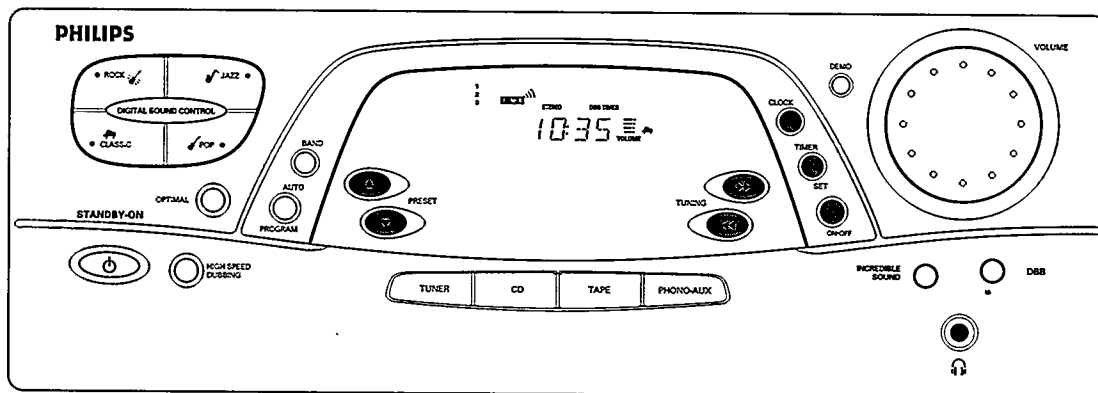

Setting the clock

The clock will display in 24-hour mode, e.g. *00:00* or *23:59*.

- 1 Press **CLOCK**.
→ "00:00" starts flashing.
- 2 Set the hour with **PRESET** ▼ or ▲.
- 3 Set the minute with **TUNING** |◀◀ or ▶▶|.
- 4 Press **CLOCK** again to store the setting.
→ The clock starts running.

Notes:

- Before setting the clock, make sure that the system is switched ON.
- When a power interruption occurs, the clock settings are erased.

Setting the Timer

- The system can switch on to TUNER or CD mode automatically at a preset time. It can serve as an alarm to wake you up. After half an hour from the preset time, the system will return to the standby mode.
- Before setting the timer, make sure the clock is set correctly.
- The timer works only once for each setting.
- **The volume of the timer will be at the last setting before the set is switched to Standby mode.**

Timer Setting

- 1 Press **TIMER SET**.
→ The **TIMER** flag flashes.
- 2 Press **PRESET** ▲ to select the desired source.
→ The display will switch as follows :
TUNER → CD → TUNER ...
- 3 Press **TIMER SET** to confirm your source selection.
→ The display will show "ON 00:00" and "00:00" flashes.
- 4 Press **PRESET** ▼ or ▲ to set the hour for the timer to start.
- 5 Press **TUNING** |◀◀ or ▶▶| to set the minutes for the timer to start.
- 6 Press **TIMER SET** to store the start time.
→ The **TIMER** is now set.
→ The **TIMER** flag remains lit.

To stop the **TIMER**

- Press **TIMER ON•OFF** on the set.
→ The **TIMER** is now off.

To start the **TIMER** again

- Press **TIMER ON•OFF** on the set.
→ The display will show the last set start time of the **TIMER** and its flag.
→ The **TIMER** flag remains lit.

Notes:

1. If the source selected is TUNER, the last tuned frequency will be switched on.
2. If the source selected is CD, the first track of the last selected disc will be played. If the CD trays are empty, the TUNER source will be selected instead.

Maintenance

Cleaning the Cabinet

- Use a soft cloth slightly moistened with a mild detergent solution. Do not use a solution containing alcohol, spirits, ammonia or abrasives.

Cleaning Discs

- When a disc becomes dirty, clean it with a cleaning cloth. Wipe the disc from the center out.

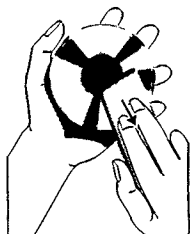

- Do not use solvents such as benzene, thinner, commercially available cleaners, or anti-static spray intended for analog records.

Cleaning the Heads and the Tape Paths

- To ensure good recording and playback quality, clean the heads (A) and (B), the capstan (C), and pressure roller (D) after every 50 hours of cassette operation.

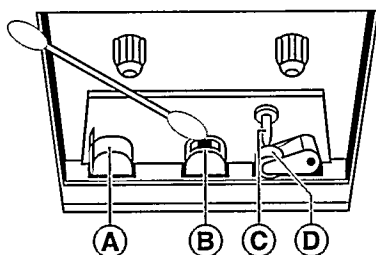

- Use a cotton swab slightly moistened with cleaning fluid or alcohol.

Demagnetizing the heads

- Use a demagnetizing cassette available at your dealer.

Specifications

AMPLIFIER

| | |
|-----------------------------|-------------------------------------|
| Standby power | 15 W |
| Output power | 2 x 160 W MPO |
| | 2 x 80 W RMS (10% THD, 6 Ω, ±1 kHz) |
| Power band width | 40 - 20000 Hz |
| Frequency response | 40 - 20000 Hz |
| Signal-to-noise ratio | ≥ 66 dB |
| Stereo separation | ≥ 52 dB (1 kHz) |
| Input sensitivity | |
| Aux | 400 mV |
| Microphone | 2.5 mV |
| Outputs | |
| Speakers | ≥ 6 Ω |
| Headphones | 1V @ 32 Ω |

TUNER

| | |
|---|-----------------------|
| FM wave range | 87.5 - 108 MHz |
| MW wave range | |
| 9 kHz Grid | 531 - 1602 kHz |
| LW wave range (<i>not for all versions</i>) | 153 - 279 kHz |
| Sensitivity at 75 Ω, 26 dB S/N ratio, FM mono | 6.9 μV |
| 46 dB signal-to-noise ratio, FM Stereo | 154 μV |
| FM Frequency response | 63 - 12500 Hz (±3 dB) |
| Signal-to-noise ratio | ≥ 55 dBA |
| Total Harmonic Distortion | ≤ 3% |

CD PLAYER

| | |
|---------------------------------|---------------|
| Frequency range | 40 - 20000 Hz |
| Signal-to-noise | ≥ 80 dB |
| Channel separation | 60 dB @ 1 kHz |
| Total harmonic distortion | - 63 dB |

CASSETTE DECK

| | |
|----------------------------|-----------------------|
| Frequency range | |
| Normal tape (type I) | 80 - 14000 Hz (±5 dB) |
| Signal-to-noise ratio | |
| Normal tape (type I) | ≥ 48 dBA |
| Wow and flutter | ≤ 0.4% |

RECORD PLAYER

| | |
|--------------------|---------------|
| Speed | 33 and 45 rpm |
| Drive system | Belt |
| PU element | ceramic |

MAIN UNIT

| | |
|------------------------------|-----------------------|
| Material/finish | Metal and polystyrene |
| Dimensions (w x h x d) | 363 x 422 x 372 mm |
| Weight | 10 kg approx. |

SPEAKER BOX

| | |
|--------------------------------|--------------------|
| Dimensions (w x h x d) | 218 x 422 x 222 mm |
| Weight | 3.75 kg approx. |
| Speaker woofer | 1 x 5.25 inches |
| Speaker tweeter | 1 x 2.5 inches |
| Speaker polydome tweeter | 1 x 1 inch |

Subject to modification

Warning: Under no circumstances should you try to repair the set yourself, as this will invalidate the warranty.

- If a fault occurs, check the points listed below before taking the set for repair.
- Should any problems persist after you have made these checks, consult your nearest dealer or service center.

| SYMPTOM | POSSIBLE CAUSE | REMEDY |
|--|---|---|
| RADIO RECEPTION | | |
| The STEREO indicator flashes. | The signal is too weak. | Adjust the antenna. |
| Severe hum or noise. | The signal strength is too weak. | Adjust the antenna. |
| | The TV or VCR is too close to the stereo system. | Separate the stereo system from the TV or VCR. Connect an external antenna for better reception. |
| CASSETTE DECK OPERATION | | |
| Recording is not possible. | No cassette in the cassette deck. | Insert a blank cassette into the cassette deck. |
| | The protection tab has been broken. | Put a piece of clear adhesive tape over the opening. |
| Recording or playback cannot be made or there is a decrease in audio level. | Dirty tape heads. | See section on cassette deck maintenance. |
| | Magnetic build-up in the record/playback head. | Use demagnetizing cassette. |
| Excessive wow or flutter, or sound drop-out. | Contamination of the capstans or pressure rollers. | See section on cassette deck maintenance. |
| CD PLAYER OPERATION | | |
| "NO DISC" is displayed. | The disc is inserted upside down. | Place CD with printed side up. |
| | Moisture condensation. | Wait until lens has adjusted to normal room temperature. |
| | There is no disc in the CD tray. | Insert a CD. |
| | The CD is dirty, badly scratched or warped. | Replace or clean the CD. |
| RECORD PLAYER | | |
| No sound. | PHONO source is not selected. | Press the PHONO • AUX key. |
| Bad sound. | Needle is dirty. | Clean or change the needle. |
| Pickup arm jumps out of the groove. | The record player is not positioned on a level surface. | Position the record player on a level surface. |
| GENERAL | | |
| Set not working. | Set does not react when buttons are pressed. | Press STANDBY-ON to switch the unit off, then switch it on again. Or, unplug the AC power plug from the wall outlet, then plug it in again. |
| No or poor sound. | Volume is not turned up. | Turn VOLUME clockwise. |
| | The headphones are connected. | Disconnect the headphones. |
| | Speakers are not connected or are connected wrongly. | Check that the speakers are connected correctly. Make sure that the stripped speaker wire is clamped. |
| Reversed left and right sound. | Speakers are connected wrongly. | Check the speaker connections and speaker location. |
| Lack of bass sound or apparently imprecise physical location of musical instruments. | Speakers are connected wrongly. | Check the speaker connection for proper phasing, red/black wires to red/black terminals. |
| Clock blinking. | There was a power disruption. | Reset the clock. |
| Remote control has no effect on the set. | The distance to the system is too large. | Reduce the distance. |
| | Batteries are inserted incorrectly. | Insert the batteries correctly. |
| | Batteries are exhausted. | Replace the batteries. |
| | Wrong sound source is selected. | Select the sound source before pressing the function button (PLAY, NEXT, PREV, etc.). |
| Timer not working. | Timer not on. | Press TIMER ON • OFF on the set to switch on the timer. |
| | Dubbing/recording is active. | Stop dubbing/recording. |
| "PRESS DEMO TO EXIT" is displayed. | Demo mode is switched on. | Press STANDBY-ON or DEMO to switch off the demonstration. |

"Meet PHILIPS at the internet
<http://www.philips.com>"

AS 765C

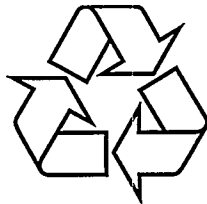

CE

Free Manuals Download Website

<http://myh66.com>

<http://usermanuals.us>

<http://www.somanuals.com>

<http://www.4manuals.cc>

<http://www.manual-lib.com>

<http://www.404manual.com>

<http://www.luxmanual.com>

<http://aubethermostatmanual.com>

Golf course search by state

<http://golfingnear.com>

Email search by domain

<http://emailbydomain.com>

Auto manuals search

<http://auto.somanuals.com>

TV manuals search

<http://tv.somanuals.com>