

Video Cassette Recorder

VRKD11YL
VRKD12BL

Instruction Book

Important!
Return your Warranty Registration
Card within 10 days. See why inside.



PHILIPS

Return your Warranty Registration card today to make sure you get all the available benefits.

Once your PHILIPS purchase is registered, you're eligible to receive all the privileges of owning a PHILIPS product. So complete and return the Warranty Registration Card enclosed with your purchase at once. And take advantage of these important benefits.

Warranty Verification	Owner Confirmation	Model Registration
Registering your product within 10 days confirms your right to maximum protection under the terms and conditions of your PHILIPS warranty.	Your completed Warranty Registration Card serves as proof of ownership in the event of product theft or loss.	Returning your Warranty Registration Card right away guarantees you'll receive all the information and special offers which you qualify for as the owner of your model.

PHILIPS

Congratulations on your purchase, and welcome to the "family!"

Dear PHILIPS product owner:

Thank you for your confidence in PHILIPS. You've selected one of the best-built, best-backed products available today. And we'll do everything in our power to keep you happy with your purchase for many years to come.

As a member of the PHILIPS "family," you're entitled to protection by one of the most comprehensive warranties and outstanding service networks in the industry.

What's more, your purchase guarantees you'll receive all the information and special offers for which you qualify, plus easy access to accessories from our convenient home shopping network.

And most importantly you can count on our uncompromising commitment to your total satisfaction.

All of this is our way of saying welcome-and thanks for investing in a PHILIPS product.

Sincerely,



Robert Minkhorst
President and Chief Executive Officer

P.S. Remember, to get the most from your PHILIPS product, you must return your Warranty Registration Card within 10 days. So please mail it to us right now!



Know these safety symbols



⚡ This "bolt of lightning" indicates uninsulated material within your unit may cause an electrical shock. For the safety of everyone in your household, please do not remove product covering.

⚠ The "exclamation point" calls attention to features for which you should read the enclosed literature closely to prevent operating and maintenance problems.

WARNING: TO PREVENT FIRE OR SHOCK HAZARD, DO NOT EXPOSE THIS EQUIPMENT TO RAIN OR MOISTURE.

CAUTION: To prevent electric shock, match wide blade of plug to wide slot, fully insert.

ATTENTION: Pour éviter les choc électriques, introduire la lame la plus large de la fiche dans la borne correspondante de la prise et pousser jusqu'au fond.

For Customer Use

Write down the Serial number, which is located on the back of the VCR. Keep this information for future reference.

Model No. _____
Serial No. _____



PHILIPS

Visit our World Wide Web Site at <http://www.philips.com>

Introduction 3

Welcome to your VCR instruction book. This book shows you how to hook up your VCR, then explains all the things the VCR can do. There's also some information for your parents or another adult - just in case you have questions about your VCR. The instructions explain all of the VCR's features, which are listed below. You cannot hurt your VCR by trying the features! So read on – and have fun.

Features

- Alarm Clock
- Automatic TV Channel Setup
- Automatic Head Cleaner
- Automatic Playback Features
- Automatic Tracking Adjustment
- Display Panel
- Forward and Reverse Searching
- On-Screen displays in English or Spanish
- One-Touch Recording (recording TV shows for 30 minutes to eight hours)
- Pausing a Picture
- Picture Select
- Real-Time Counter
- Remote Control
- Repeat Play
- S-VHS Quasi Play Back (SQPB)
- Timer Recording (recording a TV show when you are not at home)

Safety Precautions

Warning: To prevent fire or shock, do not expose this VCR to rain or moisture.

Federal Communications Commission (FCC) Warning: Any unauthorized changes or modifications to this VCR void the user's authority to operate it.

This VCR has the High Quality (HQ) system and works with Video Home System (VHS) equipment. Use only video cassette tapes that are labeled with the **VHS** mark. The use of other tapes may harm the picture quality and the video heads. Such damage may not be covered by the warranty.

Note to the Cable TV System Installer: This reminder is provided to call the Cable TV system installer's attention to Article 820-40 of the National Electrical Code, which provides guidelines for proper grounding – in particular, specifying that the cable ground shall be connected to the grounding system of the building, as close to the point of cable entry as possible.

Declaration of Conformity

Model Number: VRKD11YL/VRKD12BL
Trade Name: Philips
Responsible Party: Philips Consumer Electronics
P.O. Box 14810
Knoxville, TN 37914-1810
(865) 521-4316



As an ENERGY STAR® Partner, Philips Consumer Electronics has determined that this product meets the ENERGY STAR® guidelines for energy efficiency. ENERGY STAR® is a U.S. registered mark. Using products with the ENERGY STAR® label can save energy. Saving energy reduces air pollution and lowers utility bills.

Copyright 2000 Philips Consumer Electronics. All rights reserved.

Helpful Hints

- Before doing anything else, write down the VCR's model and serial numbers on page two. These numbers will help us assist you if you ever call for help.
- Your new VCR and its packaging contain materials that can be recycled and reused. Specialized companies can recycle your product to increase the amount of reusable materials and to minimize the amount that needs to be properly disposed. Your product uses batteries that should not be thrown away when depleted but should be disposed of as small chemical waste. Ask about your community's rules on disposal of your old product, batteries, and packaging.

4 Table of Contents

Setting Up Your VCR

Introduction	3
Table of Contents	4
Before Using Your VCR	5
Using the Alarm Clock	6
Hookups Without a Cable Box/Direct Broadcast System	7
Hookups With a Cable Box/Direct Broadcast System	8-9
Hookups With a Stereo TV	10
Turning on Your VCR	11
Automatic TV Channel Setup	12-13
Setting the VCR Clock	14-15
Choosing a Language	16

Description of Controls

On-Screen Displays	17
Remote Control Buttons	18-19
VCR Display Panel	20
Front Panel	21
Back Panel	22

Basic Operations

Playing	23
Recording	24

Recording

One-Touch Recording	25
Timer Recording	26-30
Recording One Channel/Watching Another	31
Rerecording (Copying Tapes)	32

Playing

Repeat Play	33
Forward and Reverse Searching/Pausing a Picture	34
Picture Select	35
Real-Time Counter Memory	36
Automatic Playback Features	37

Information You May Need

Helpful Hints	38-39
Limited Warranty	40
Dictionary/Specifications	41
Index	42
Accessories	43

Before Using Your VCR 5

Putting Batteries in the Remote Control

1

Remove the battery compartment lid on the bottom of the remote control by pressing the tab, then lifting the lid.

2

Insert two AA batteries inside the battery compartment with their + and - ends placed as shown in the picture at right.

3

Replace the battery compartment lid.

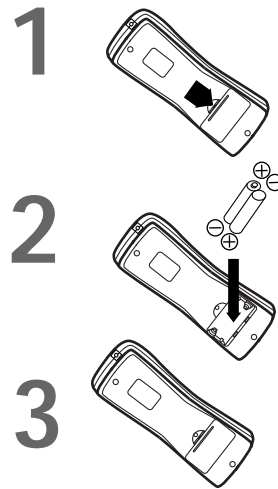

Using the Remote Control Holder

When you do not use the remote control, keep it in the remote control holder (supplied).

1

Insert the bent hooks (A) of the remote control holder into the fourth row of holes (C) on the right side of the VCR. Make sure the top hook is in the top hole.

2

Pop the straight hooks (B) of the remote control holder into the first row of holes (D) on the right side of the VCR.

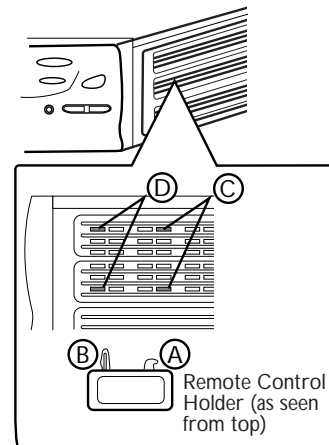

Erasure Prevention

Video cassette tapes have tabs to make sure recordings are not erased accidentally. The tab is in the bottom left corner on the front of the tape.

1

To keep from erasing a tape, break off the tab with a screwdriver.

2

To allow new recording on the tape, cover the hole with clear tape.

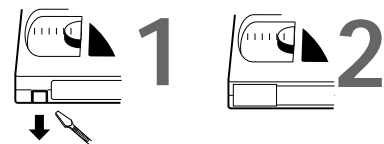

VCR maintenance

- In this VCR, use only tapes with the **VHS** mark.
- Remove any stickers or labels from the video cassette tape before putting the tape in the VCR. Labels can jam the VCR.
- Video heads are an important part of your VCR. You can't see them, but the VCR automatically cleans its video heads. The video heads will require replacement eventually. Only an authorized service center should replace the heads.

Helpful Hints

- The remote control and its batteries are supplied.
- Do not mix alkaline and manganese batteries.
- Do not mix old and new batteries.

6 Using the Alarm Clock

Putting Batteries in the Alarm Clock

1

Remove the battery compartment lid on the back of the alarm clock. Use your finger or fingernail to flip down the lid.

2

Insert one AA battery inside the battery compartment with its + and - ends placed as shown in the picture at right.

3

Replace the battery compartment lid.

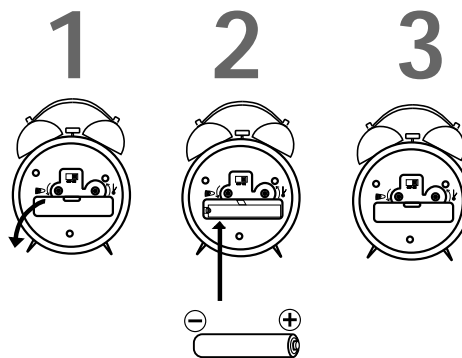

Using the Alarm Clock Holder

1

Pop the three slots of the alarm clock holder into the three holes on the left side of the front of the VCR. The holder will curve down, like a bowl, when placed correctly.

2

A velcro strip is supplied. Peel off the tape backing, then stick one piece of the velcro to the front of the VCR and one piece to the top of the clock as shown in the picture at right. Make sure the velcro pieces will touch when the alarm clock is in place in the holder.

3

Set the alarm clock in the clock holder.

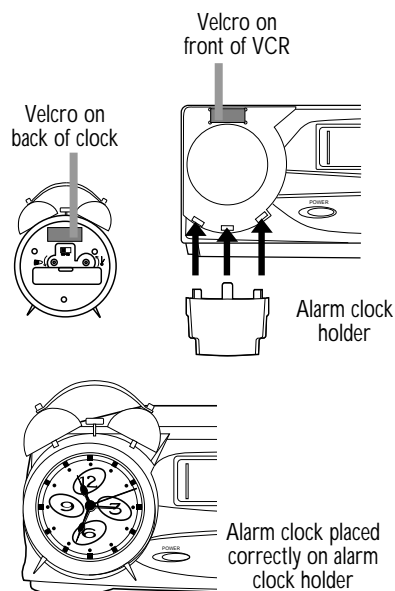

Setting the Time and the Alarm

1

Turn the right knob to set the current time.

2

Turn the left knob to set the time for the alarm.

3

Set the OFF/ON switch to ON. At the proper time, the alarm will sound. The alarm will sound until you move the OFF/ON switch to OFF.

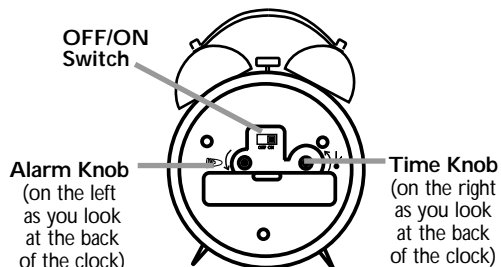

- Set the VCR's internal clock for a timer recording or One-Touch Recording. *Details are on pages 14-15.*
- When you do not use the alarm, set the OFF/ON switch on the back of the alarm clock to OFF.
- The alarm will sound in the next 12-hour period. The alarm clock does not have AM or PM settings.
- The alarm sound is a beep. The bells on the top of the clock are for appearance only. The bells will not ring.

Hookups Without a Cable Box / Direct Broadcast System 7

The easiest connection – just a TV, VCR, and antenna or cable – is shown below. If you have a Cable Box or a Direct Broadcast System, please see pages eight-nine. If you have a Stereo TV, please see page 10. After you hook up the VCR, go to page 11 to turn on the VCR.

1

Disconnect the antenna or cable from your TV.

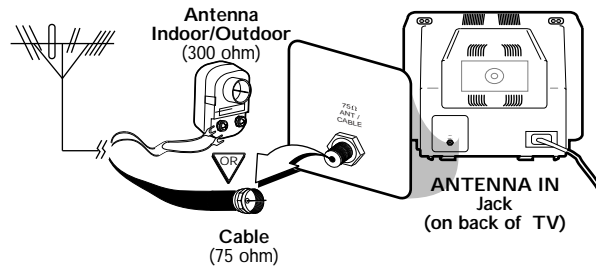

2

Connect the antenna or cable to the ANT(enna) IN Jack of your VCR.

Connect the RF coaxial cable (supplied) to the OUT Jack on the back of the VCR and to the ANTENNA IN Jack on the TV.

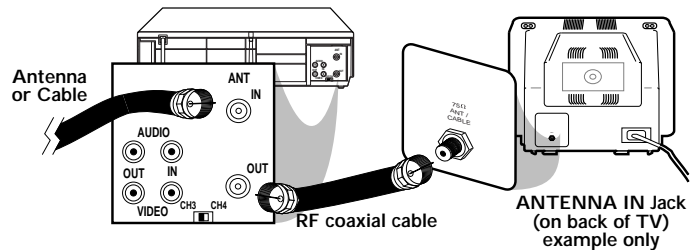

3

Plug in the power cords of the TV and the VCR.

4

Set the CH3/CH4 switch on the back of the VCR to CH3 or CH4, whichever channel is not used or least used in your area. **Set the TV to the same channel.** For example, when playing a tape, if the CH3/CH4 switch is set to CH3, the TV should be on channel 03.

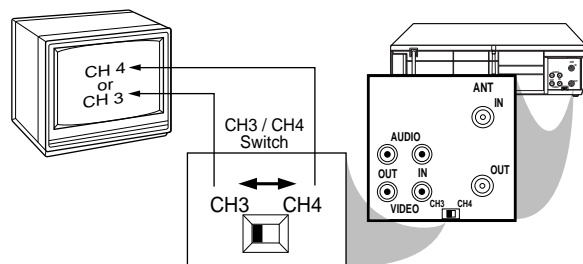

5

You are ready to turn on the VCR. Please go to page 11 before turning on the VCR.

8 Hookups With a Cable Box/Direct Broadcast System

There are two ways to connect your Cable Box/DBS to the VCR. With this connection:

- You may view any channel.
- You must select channels at the Cable Box/DBS. Channels cannot be changed at the VCR.
- You may not view a channel other than the one you are recording.
- You may not program channels at the VCR.
- You can only program a timer recording for one channel at a time. Set the TV and the VCR to the Cable Box/DBS output channel (channel 03 or 04), and set your Cable Box/DBS to the channel you want to record. When you enter the channel you want to record in a timer recording, select channel 03 or 04 (the Cable Box/DBS output channel). (This is step 7 on page 28.) Leave the Cable Box/DBS on for a timer recording.

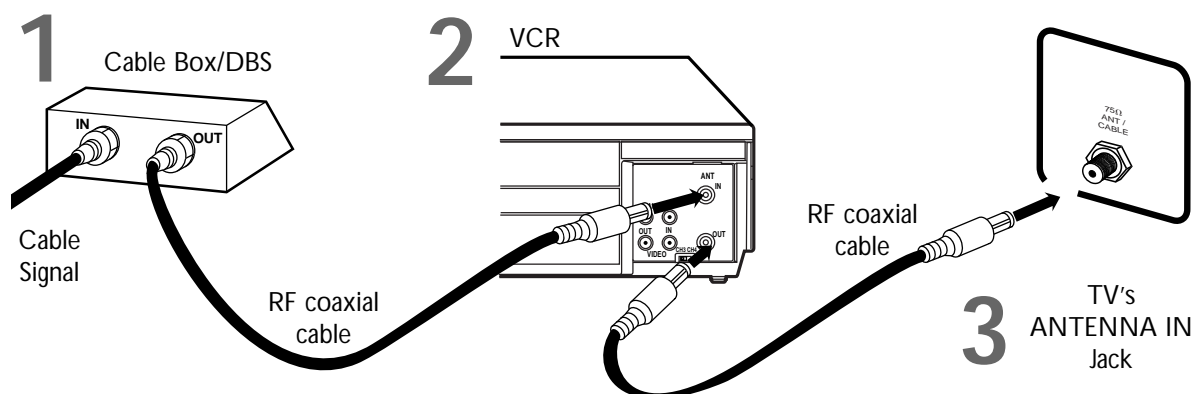

Connections

1

Connect a Cable signal to the IN Jack on the Cable Box/DBS.

2

Use an RF coaxial cable (supplied) to connect the OUT Jack on the Cable Box/DBS to the ANT(enna) IN Jack on the VCR.

3

Use a second RF coaxial cable to connect the OUT Jack on the VCR to the TV's ANTENNA IN Jack.

Recording/Viewing Any Channel

1

With the VCR on and in VCR position (the VCR/TV light will appear on the front of the VCR), use the **CHANNEL ▲/▼** button to set the VCR to the Cable Box/DBS output channel (channel 03 or 04).

2

Set the TV to the same channel to which you set the VCR. Set the CH3/CH4 switch on the back of the VCR to the same channel.

3

Select the channel you want to view/record at the Cable Box/DBS.

Hookups With a Cable Box/Direct Broadcast System (cont'd) 9

With this connection:

- You may watch one channel while recording another.
- You may not record scrambled channels.

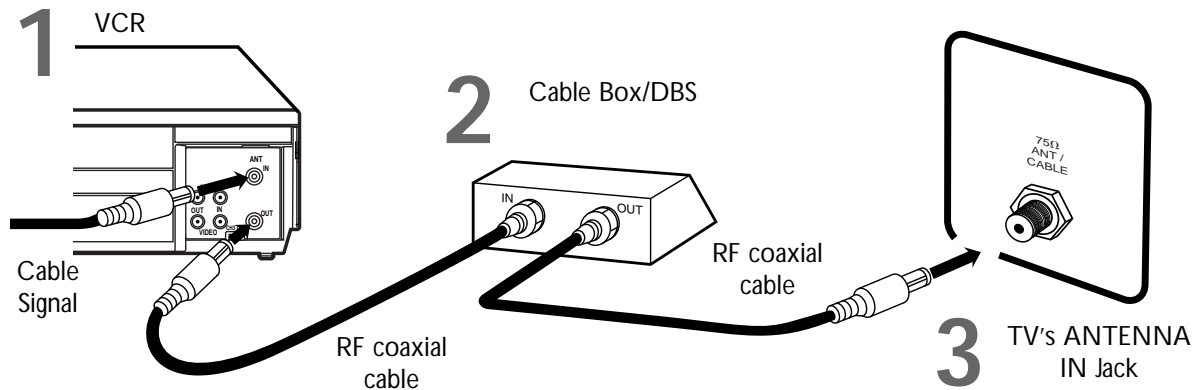

Connections

1

Connect a Cable signal to the VCR's ANT(enna) IN Jack.

2

Use an RF coaxial cable (supplied) to connect the OUT Jack on the VCR to the IN Jack on the Cable Box/DBS.

3

Use a second RF coaxial cable to connect the OUT Jack on the Cable Box/DBS to the ANTENNA IN Jack on the TV.

Recording One Channel/Watching Another

1

Put the Cable Box/DBS on the same channel as the VCR's CH3/CH4 switch. (Make sure the TV is on the Cable Box/DBS output channel, 03 or 04.)

Then, with the VCR in VCR position (the VCR/TV light will appear on the front of the VCR), use the CHANNEL ▲/▼ button to select the channel you want to record at the VCR. Start the recording.

2

Press the VCR/TV button once so that the VCR/TV light appears.

3

Select the channel you want to watch at the Cable Box/DBS.

Helpful Hint

- When you play a tape, make sure the Cable Box/DBS is set to the same channel as the CH3/CH4 switch on the VCR. Set the TV to the Cable Box/DBS output channel (03 or 04).

10 Hookups With a Stereo TV

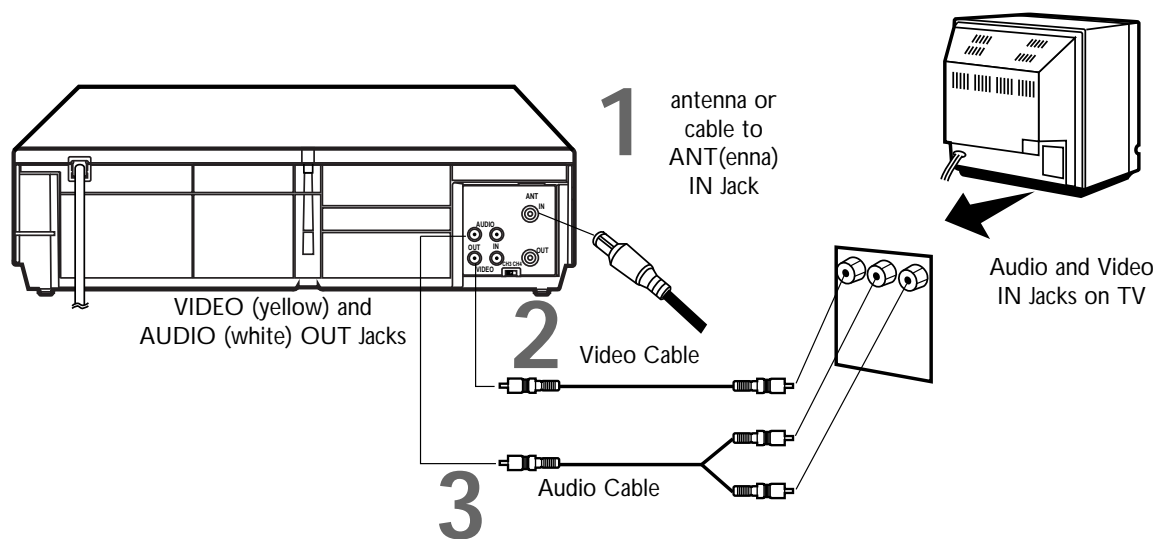

- Audio and Video cables are not supplied.

1

Connect the antenna or cable to the ANT(enna) IN Jack on the back of the VCR.

2

Connect a video cable to the yellow VIDEO OUT Jack on the back of the VCR. Then, connect the other end of the video cable to the VIDEO IN Jack on your TV.

3

Connect an audio cable to the white AUDIO OUT Jack on the back of the VCR. Then, connect the other end of the audio cable to the AUDIO IN Jack on your TV.

(If your TV has Right and Left AUDIO IN Jacks, you must use a "Y" splitter audio cable as illustrated to deliver audio to the TV's right and left channels.)

4

Turn on your TV, making sure it is in Line Input (or Auxiliary In or Video In) mode. Please refer to your TV instruction book for details.

Helpful Hint

- This hookup will not give you stereo sound. To get stereo sound, use the connections on page seven and select the channel to be viewed at the TV (with the VCR turned off).

Turning on Your VCR 11

- Before turning on your VCR, make sure there are batteries in the remote control and the VCR and TV are connected (see pages five and seven-10).
- You can not set up channels if you are using a Cable Box/DBS.
- The instructions on this page only work when you turn on the VCR for the first time. If there is a power failure or if the VCR is unplugged for more than one minute, you may need to repeat the instructions on this page.

1

Press the **POWER** button. The POWER light and the VCR/TV light will appear on the front of the VCR.

2

Turn on the TV. Set it to the same channel as the **CH3/CH4** switch on the back of the VCR. The display shown below will appear on the TV.

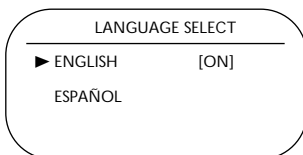

3

Press the **PLAY** button or the **STOP** button to select **ENGLISH** or **ESPAÑOL**. [ON] will appear beside your choice.

4

Press the **F.FWD** button or the **MENU** button. **AUTO SET UP** will appear on the screen.



5

Press the **MENU** button, the **F.FWD** button, or the **REW(ind)** button to begin automatic channel setup. **AUTO SET UP** will flash on the screen and channel numbers will appear in the top right corner of the screen. When channels are set up, the TV will go to the lowest channel available. The VCR will memorize all available channels, so when you use the **CHANNEL ▲/▼** button, you'll only scan through channels that you receive.

2 Turn on the TV. Set it to channel 3 or 4.

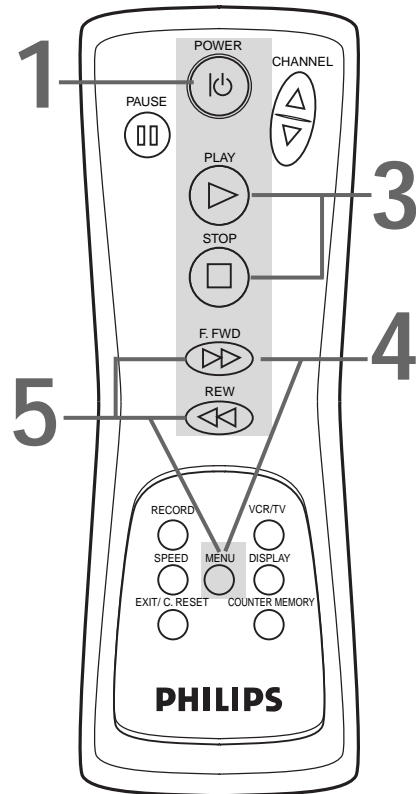

Helpful Hints

- If you do not see any messages when you turn on the VCR, check your hookups, then try again. If you still do not see any messages, follow the steps under "Automatic TV Channel Setup" on page 12 and "Choosing a Language" on page 16.
- If you try to set up channels when there is no antenna or cable connected to the VCR, channel setup will appear to take place. Eventually, **AUTO SET UP** will appear on the screen steadily, and channel setup will stop. Connect an antenna or cable to the **ANT(enna) IN** jack of the VCR, then press the **MENU** button, the **F.FWD** button, or the **REW(ind)** button again. Channel setup will begin again.

12 Automatic TV Channel Setup

Although your VCR may automatically set up the TV channels you receive when you turn it on for the first time, this function lets you set up channels again. Make sure:

- The VCR is on and is in VCR position. (The VCR/TV light will appear on the front of the VCR. If it does not, press the VCR/TV button once.)

1

Press the **MENU** button until the main menu appears.

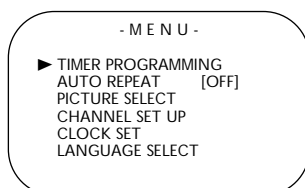

2

Press the **PLAY** button or the **STOP** button repeatedly to select **CHANNEL SET UP**. Then, press the **F.FWD** button.

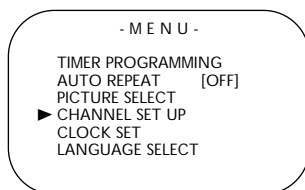

3

AUTO SET UP will be selected. Or, press the **PLAY** button or the **STOP** button repeatedly to select **AUTO SET UP**.

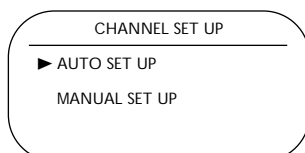

4

Press the **F.FWD** button. The VCR will memorize all available TV channels. When setup is complete, the lowest channel you receive will appear on the TV.

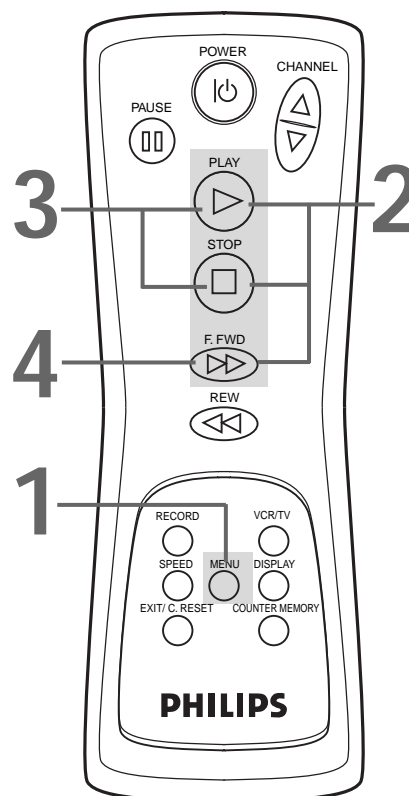

Helpful Hints

- Line Input mode will always be stored in the VCR's memory as channel 00. When you select channel 00 with the CHANNEL ▲/▼ button LineIn Rear (L1) will appear on the screen.
- You can not program channels if you are using a Cable Box/DBS. Details are on pages eight-nine.

Automatic TV Channel Setup (cont'd) 13

Adding/Deleting Channels

The channels you no longer receive or seldom watch can be deleted from the memory. You also may add new channels into the memory. Make sure:

- The VCR is on and in VCR position. (The VCR/TV light will appear. If it does not, press the VCR/TV button once.)

1

Press the **MENU** button until the main menu appears.

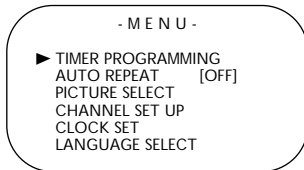

2

Press the **PLAY** button or the **STOP** button repeatedly to select **CHANNEL SET UP**. Then, press the **F.FWD** button.

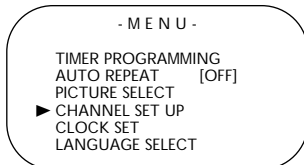

3

Press the **PLAY** button or the **STOP** button repeatedly to select **MANUAL SET UP**. Then, press the **F.FWD** button.

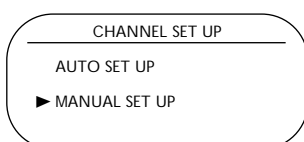

4

Press the **PLAY** button or the **STOP** button repeatedly until your desired channel number appears.

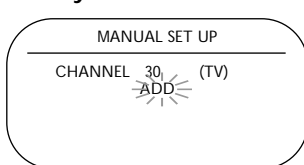

5

Press the **F.FWD** button or the **REW(ind)** button so that **ADD** or **DELETE** flashes on the screen.

6

While your choice is flashing, press the **EXIT/C.RESET** button. The channel you added or deleted will appear. The channel will be added or deleted, whichever was flashing on the screen when you exited the menu.

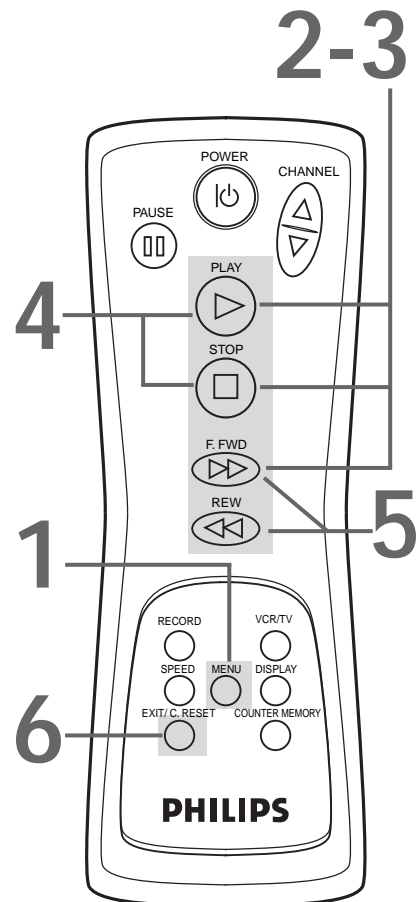

14 Setting the VCR Clock

Follow the steps below to set your VCR's internal clock. Make sure:

- The VCR is on and in VCR position. (The VCR/TV light will appear. If it does not, press the VCR/TV button once.)

1

Press the **MENU** button until the main menu appears.

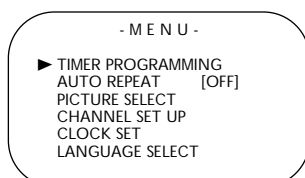

2

Press the **PLAY** button or the **STOP** button repeatedly to select **CLOCK SET**. Then, press the **F.FWD** button.

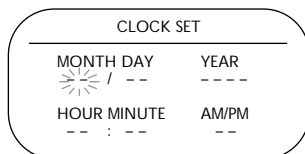

3

While the **MONTH** space is flashing, press the **PLAY** button or the **STOP** button repeatedly until the desired month appears. Then, press the **F.FWD** button.

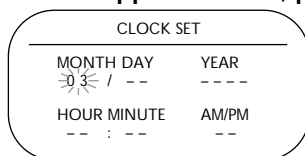

4

While the **DAY** space is flashing, press the **PLAY** button or the **STOP** button repeatedly until the desired day appears. Then, press the **F.FWD** button.

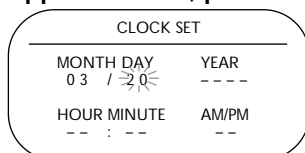

5

While the **YEAR** space is flashing, press the **PLAY** button or the **STOP** button repeatedly until the desired year appears. Press the **F.FWD** button. The day of the week will appear automatically.

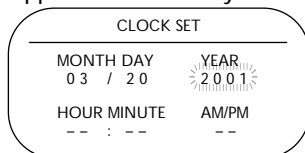

2-5

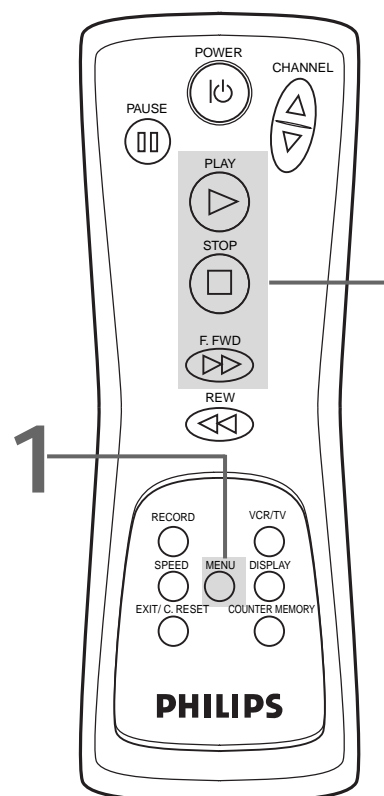

Helpful Hints

- If the clock has never been set, the **CLOCK SET** menu may appear immediately when you press the **MENU** button. If this happens, follow the instructions from step 3 above.
- To see the time on the TV, press the **DISPLAY** button repeatedly until the time appears on the screen.
- Power failures that last for more than one minute can cause you to lose your clock setting.
- Press the **REW(ind)** button to go back one step from the current step during steps 4-8.

Setting the VCR Clock (cont'd) 15

6

While the HOUR space is flashing, press the PLAY button or the STOP button repeatedly until the desired hour appears. Then, press the F.FWD button.

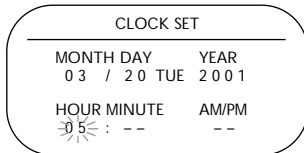

7

While the MINUTE space is flashing, press the PLAY button or the STOP button repeatedly until the desired minute appears. Then, press the F.FWD button.

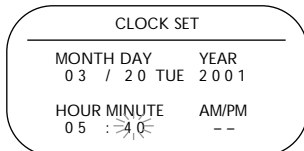

8

While the AM or PM space is flashing, press the PLAY button or the STOP button repeatedly to point to AM or PM. Your selection will flash on the screen in the AM/PM space.

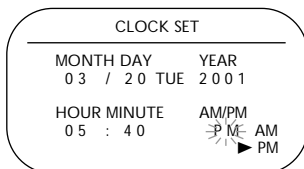

9

Press the EXIT/C.RESET button or the F.FWD button to start the VCR clock.

6-7

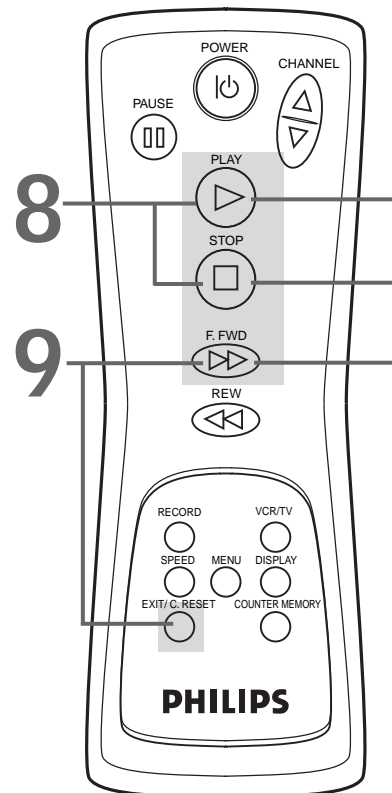

Helpful Hints

- The VCR clock does not affect the setting of the alarm clock.
- To reset the clock, follow steps 1-2 on page 14. Select the information you want to change using the F.FWD button or the REW(ind) button. When the desired information is flashing, use the PLAY button or the STOP button to enter the correct information. Press the EXIT/C.RESET button when you are finished.

16 Choosing a Language

Follow the steps below to change the language of the on-screen menus and displays. Make sure:

- The VCR is on and in VCR position. (The VCR/TV light will appear. If it does not, press the VCR/TV button once.)

1

Press the **MENU** button until the main menu appears.

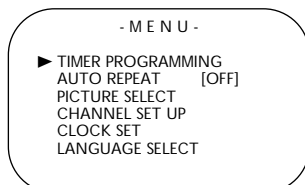

2

Press the **PLAY** button or the **STOP** button repeatedly to select **LANGUAGE SELECT**. Then, press the **F.FWD** button.

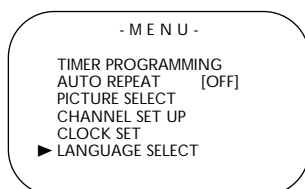

3

Press the **PLAY** button or the **STOP** button to select **ENGLISH** or **ESPAÑOL**. [ON] will appear beside your choice.

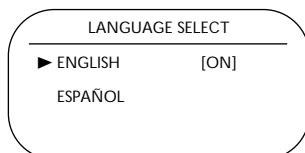

4

Press the **EXIT/C. RESET** button when you are finished.

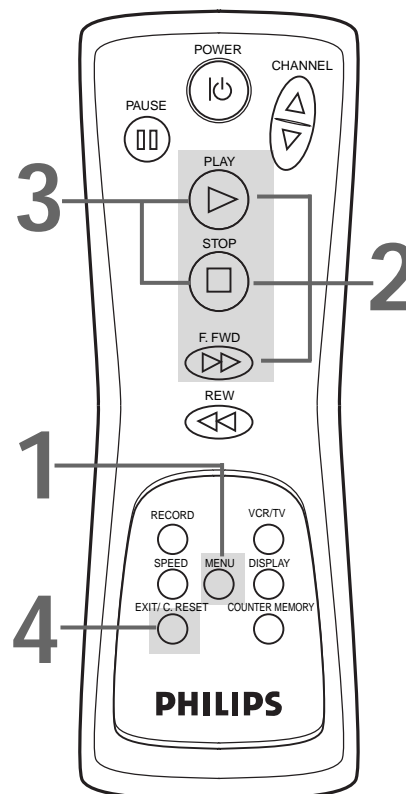

Helpful Hint

- If you accidentally select Spanish and need English:
 - 1) Press the **MENU** button until the main menu appears. (MENU will be at the top of the screen.)
 - 2) Press the **PLAY** button or the **STOP** button repeatedly to choose **SELEC. IDIOMA**, then press the **F.FWD** button.
 - 3) Press the **PLAY** button or the **STOP** button to select **ENGLISH**.
 - 4) Press the **EXIT/C.RESET** button.

On-Screen Displays 17

You may access on-screen displays by pressing the DISPLAY button repeatedly. On-screen displays may include the current time, channel, and other information.

- Press the DISPLAY button once. The COUNT information will appear for five seconds. After five seconds, only the real-time counter will appear on the screen. This counter shows you the elapsed playing time of the tape (from the point at which the real-time counter was set to zero).
- Press the DISPLAY button once again. The CLOCK information will appear for five seconds. After five seconds, only the current time will appear on the screen (the clock must be set). (If you are watching TV, the current channel number will also appear on the screen.)
- Press the DISPLAY button once again. The on-screen displays will disappear.

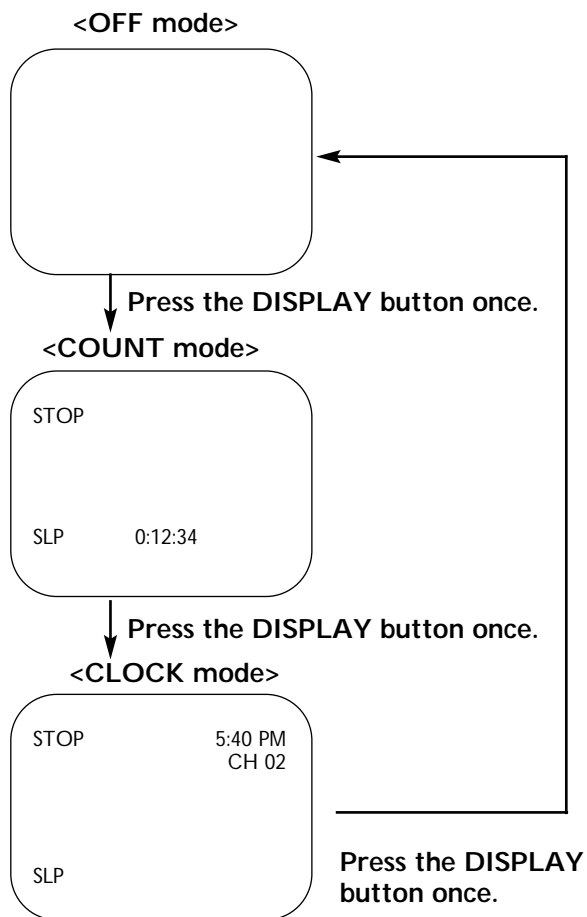

Helpful Hints

- You can not see the on-screen displays during a forward or reverse search, when the menu is on the screen, or when viewing a paused picture.
- Channel numbers appear on the screen for a few seconds when you change channels.

18 Remote Control Buttons

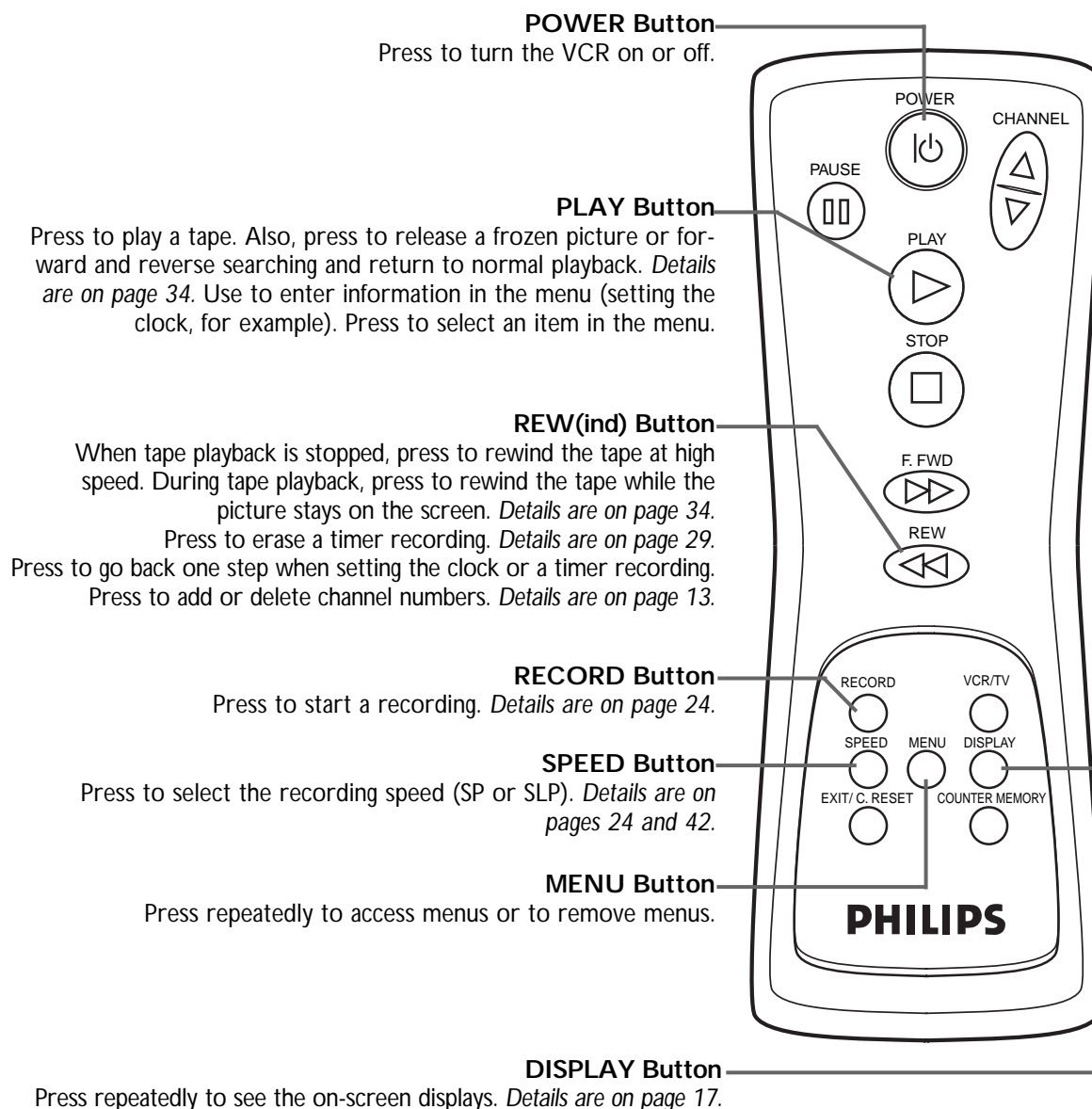

Helpful Hint

- Point the VCR remote control at the VCR's remote sensor (see page 21), not toward your TV.
- Do not put objects between the remote control and the VCR.

Remote Control Buttons (cont'd) 19

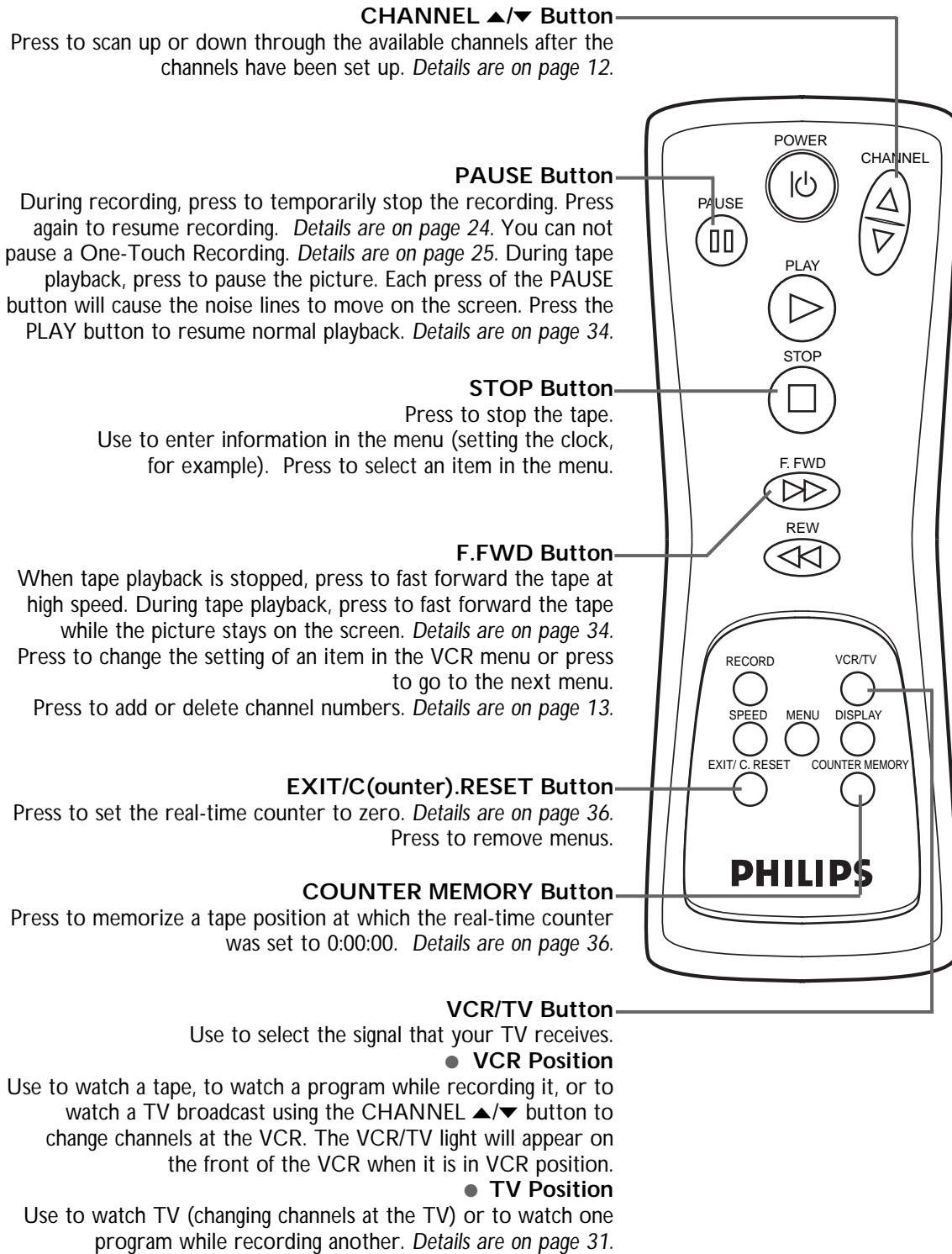

20 VCR Display Panel

Cassette Compartment
Insert a video cassette tape here.
Do not place anything else in this compartment.

VCR Display Panel
These lights explain the current activity of the VCR.

Alarm Clock
Details are on page six.

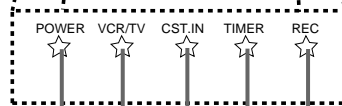
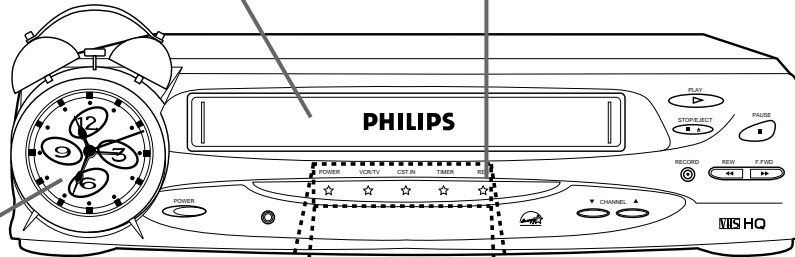

POWER Light
This light appears when the VCR power is on.

VCR/TV Light
This light appears when the VCR is in VCR position. *Details are on page 19.*

REC(ord) Light
This light appears during a recording. It flashes when a recording is paused.

TIMER Light
This light glows when the VCR is turned off to set a timer recording or during a One-Touch Recording. It flashes if the power is off for a timer recording, but there is no tape in the VCR. It flashes when all timer recordings are finished.

CST.IN Light
This light appears when a tape is in the VCR.

Remote Sensor
Point the remote control here so you can operate your VCR from a distance.

POWER Button
Press to turn the VCR power on and off.

PAUSE Button

While recording, press to temporarily stop the recording. Press a second time to resume normal recording. *Details are on page 24.* You can not pause a One-Touch Recording. *Details are on page 25.* During tape playback, press to pause the picture. Each press of the PAUSE button will cause the noise lines to move on the screen. Press the PLAY button to resume normal playback. *Details are on page 34.*

STOP/EJECT Button

Press once to stop the tape. When tape playback is stopped, press to eject the tape. Press to select an item in the VCR menu.

PLAY Button

Press to play a tape. Also, press to release a frozen picture or a forward or reverse search and return to normal playback. *Details are on page 34.* Press to select an item in the VCR menu.

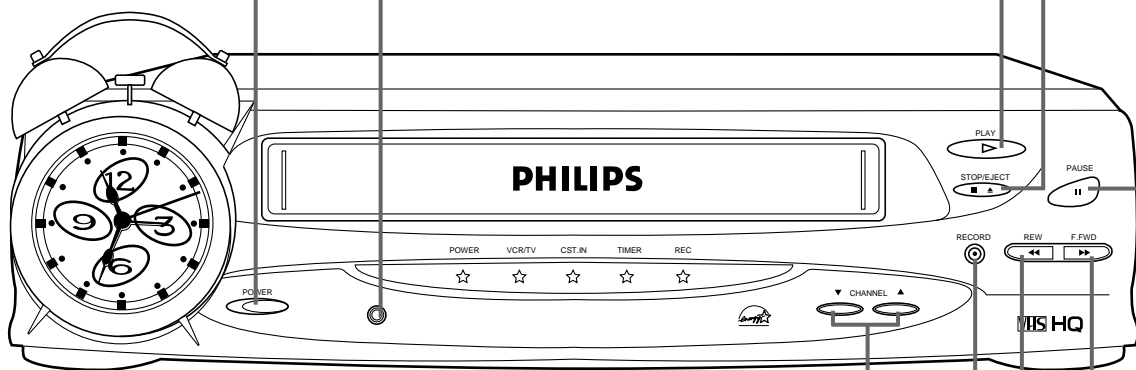

CHANNEL ▲/▼ Buttons
Press to scan through the channels. During normal tape playback, press the CHANNEL ▲/▼ buttons to adjust the tracking. *Details are on page 37.*

RECORD Button
Press once to start a recording. *Details are on page 24.* Press repeatedly to start a One-Touch Recording (an immediate recording, 30 minutes to eight hours long) of the channel you are watching. *Details are on page 25.*

REW(ind) Button
When tape playback is stopped, press to rewind the tape at high speed. During tape playback, press to rewind the tape while the picture stays on the screen. *Details are on page 34.* Press to go back one step when setting the clock or a timer recording.

F.FWD (Fast Forward) Button
When tape playback is stopped, press to fast forward the tape at high speed. During tape playback, press to fast forward the tape while the picture stays on the screen. *Details are on page 34.* Press to select an item in the VCR menu or to change the setting of an item.

22 Back Panel

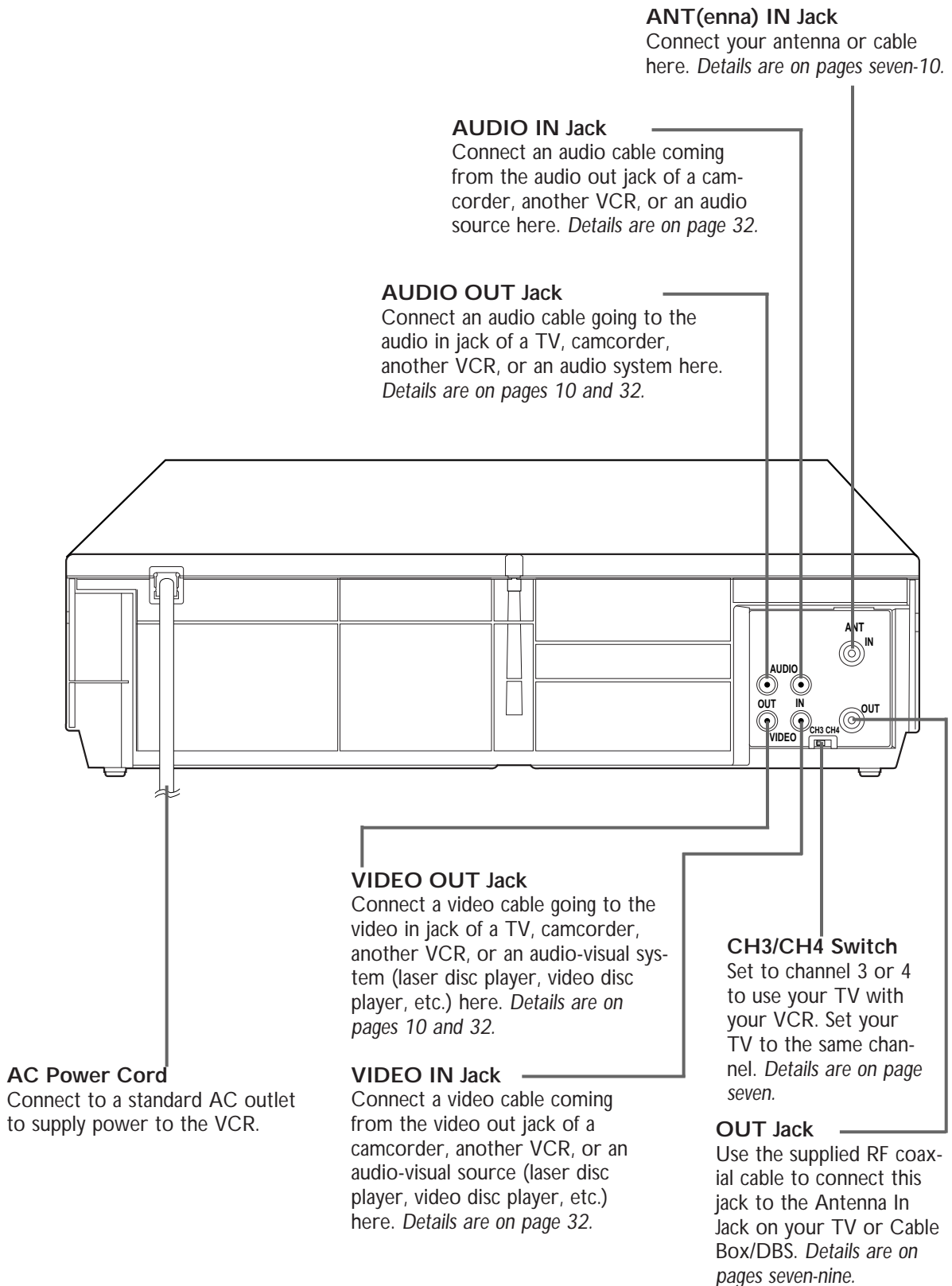

Playing 23

Read and follow the steps below to play a tape.

1

Turn on the TV and set it to channel 3 or 4, whichever channel to which the CH3/CH4 switch on the back of the VCR is set.

2

Insert a tape in the VCR. The POWER, VCR/TV, and CST.IN lights will appear. If the tape's record tab has been removed, playback will begin automatically. (Tab details are on page five.)

3

If playback does not start automatically, press the PLAY button.

4

Press the STOP button to stop playback.

5

Press the REW(ind) button to rewind the tape.

6

When the tape has finished rewinding, press the STOP/EJECT button on the VCR to remove the tape.

1 Turn on the TV.

2 Insert a tape.

6 Press the STOP/EJECT button on the VCR.

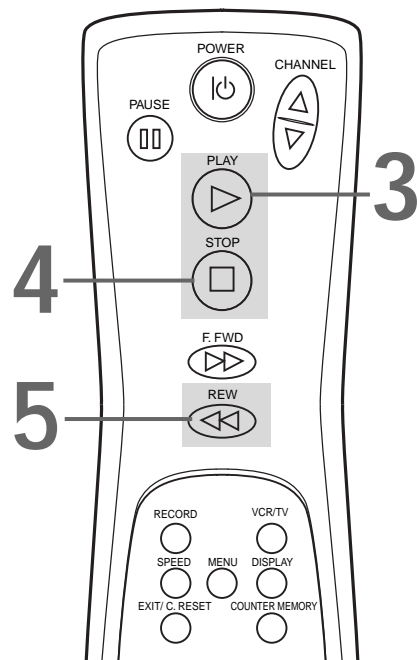

S-VHS Quasi Play Back (SQPB)

This VCR has a SQPB function that lets you view a tape recorded in S-VHS format. A tape recorded in S-VHS format will play the same as a tape recorded in normal format.

When you play an S-VHS tape, you can not get the picture quality that would be available on an S-VHS VCR. Noise lines (black and white streaks) may appear on the picture.

Helpful Hints

- If the tape you want to play is already in the VCR, make sure the VCR power is on and the VCR is in VCR position. (Press the VCR/TV button so that the VCR/TV light appears.) Then, press the PLAY button.
- Other playback options and features are on pages 33-37.
- If AUTO REPEAT is set to ON, playback will begin automatically, even when the record tab is intact. Details are on page 33.

24 Recording

Read and follow the steps below to record a television program.

1

Turn on the TV; set it to channel 3 or 4, whichever channel the CH3/CH4 switch on the back of the VCR is set to.

2

Insert a tape with its record tab intact (see page five) in the VCR. The POWER, VCR/TV, and CST.IN lights will appear.

3

If the VCR/TV light does not appear, press the VCR/TV button so that the VCR/TV light appears.

4

Press the SPEED button until the desired tape speed (SP or SLP) appears on the screen. The tape speed will disappear after about five seconds.

You can change the tape speed while the VCR is recording, but some distortion may appear on the tape. Details about tape speed are on page 42.

5

Use the CHANNEL ▲/▼ button to select the channel to be recorded.

6

Press the RECORD button once to start recording. The REC(ord) light will appear. If the tape is missing the record tab, the VCR will eject the tape.

7

To pause the recording (for example, during commercials), press the PAUSE button once. The REC(ord) light will flash.

To resume recording, press the RECORD button or the PAUSE button again. The REC(ord) light will appear.

8

Press the STOP button to stop recording.

1 Turn on the TV.

2 Insert a tape.

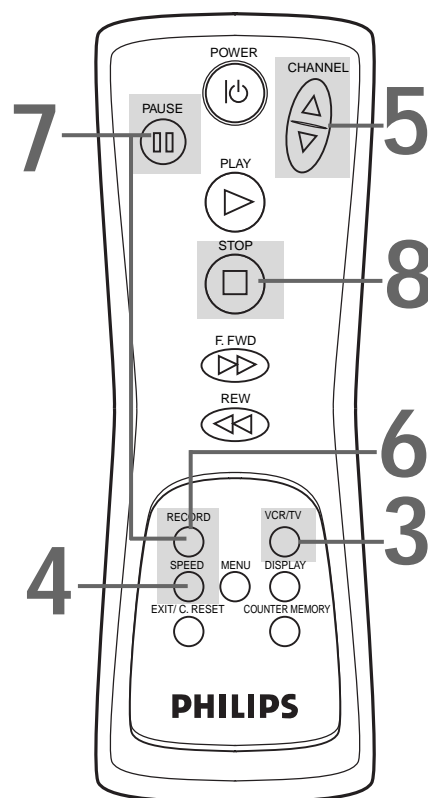

Helpful Hints

- Other recording options are on pages 25-32.
- The VCR will record in a preset volume.
- Pause mode will automatically switch to Stop mode after five minutes to protect the VCR and the tape from damage. When a recording is paused, you may review the pause time remaining with the ■ marks on the screen. Each ■ mark equals one minute remaining. During the last minute of paused recording, the ■ mark will flash.
- If a menu is on the TV screen, the RECORD button on the remote control will not work. Press the EXIT/C.RESET button to remove the menu. Then, press the RECORD button.

One-Touch Recording 25

One-Touch Recording (OTR) lets you record for 30 minutes to eight hours. Before you begin, make sure:

- Channels are set up. *Details are on page 12.*
- The desired recording speed (SP, SLP) has been selected with the SPEED button. *Details are on page 42.*
- There is a tape in the VCR. Make sure the tape's record tab is intact and the tape is long enough to record the program(s). *Details are on page five.*
- The VCR is in VCR position. (The VCR/TV light will appear. If it does not, press the VCR/TV button once.)

Starting an OTR

1

Use the CHANNEL ▲/▼ button to select the channel you want to record.

2

Press the RECORD button on the VCR repeatedly until the desired recording length (30 minutes to eight hours) appears in the upper left corner of the TV screen.

Recording will begin immediately.

- The RECORD button on the remote control cannot be used for One-Touch Recording.

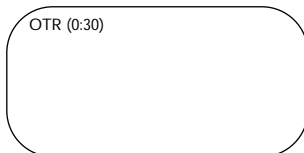

Stopping an OTR

To stop an OTR before recording is finished, press the STOP button on the remote control. To cancel the OTR but continue recording, press the RECORD button **on the VCR** repeatedly until REC appears in the upper left corner of the screen.

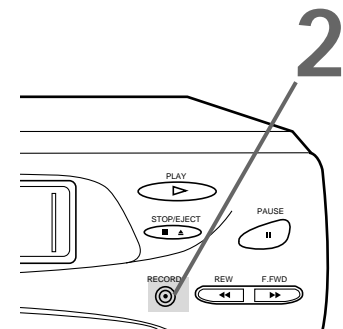
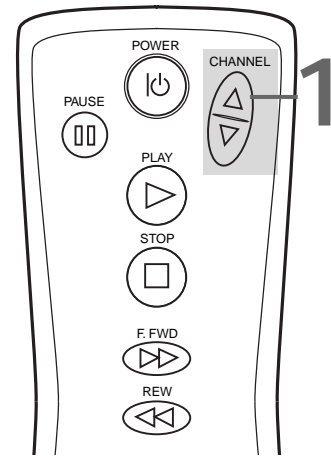

Helpful Hints

- To change the recording length while an OTR is in progress, press the RECORD button **on the VCR** repeatedly until the desired length appears on the TV screen.
- You can not pause recording during an OTR.
- If the preset time for a timer recording comes up during an OTR, the OTR has priority. The timer recording will not occur.
- To show the time remaining for an OTR, press the DISPLAY button repeatedly until OTR and the time remaining appear in the upper left corner of the screen.
- If the end of the tape is reached during an OTR, the VCR will stop recording, eject the tape, and turn itself off.

26 Timer Recording

Follow the steps below to make your VCR record TV programs while you're away from home. You can have up to seven timer recordings. For each one, the VCR will turn itself on, record, and turn itself off automatically. Before you begin make sure:

- Channels are set up. *Details are on page 12.*
- The VCR clock is set. *Details are on pages 14-15.*
- There is a tape in the VCR. Make sure the tape's record tab is intact and the tape is long enough to record the program(s). *Details are on page five.*
- The VCR is in VCR position. The VCR/TV light will appear. If it does not, press the VCR/TV button once. *Details are on pages 19-20.*

1

First, press the **MENU** button until the main menu appears. **TIMER PROGRAMMING** will be selected. Press the **F.FWD** button. Program numbers that do not have a timer recording stored will flash.

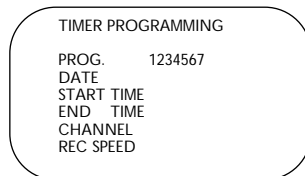
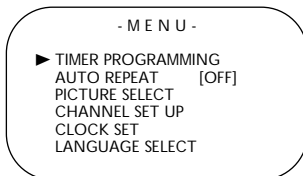

2

Press the **PLAY** button or the **STOP** button repeatedly to select a program number. Then, press the **F.FWD** button. (If you select a program number that already has a timer recording stored, information about that program will appear. Press the **PLAY** button or the **STOP** button to select another program number.)

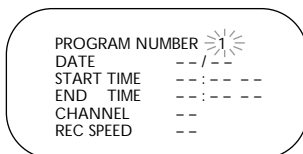

3

Press the **PLAY** button or the **STOP** button repeatedly to select a **ONCE**, **DAILY**, or **WEEKLY** recording. When the arrow is beside your choice, press the **F.FWD** button.

- **ONCE** - The VCR will record a TV program on any day you choose, up to 12 months away.
- **DAILY** - The VCR will record a TV program at the same time on the same channel every day, Monday through Friday.
- **WEEKLY** - The VCR will record a TV program at the same time on the same channel every week, for example, every Monday.

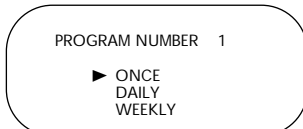

2-3

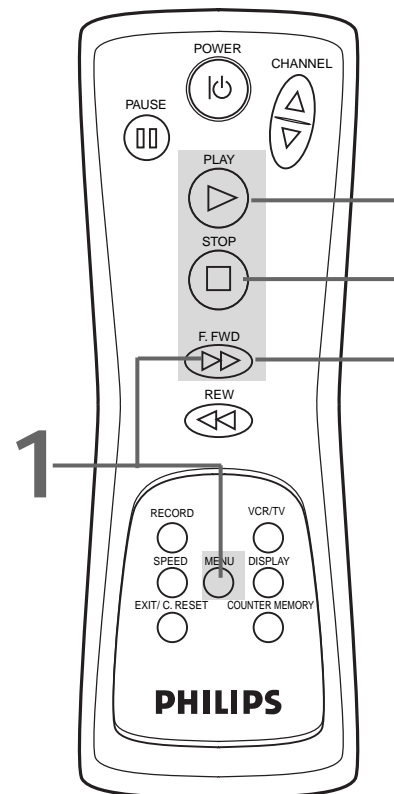

Helpful Hints

- The **TIMER PROGRAMMING** menu will not appear at step 1 if the VCR clock is not set. Follow the steps on pages 14-15 to set the VCR clock.
- Enter the information while the space is flashing.

4

Press the **PLAY** button or the **STOP** button repeatedly until the desired month appears. Then, press the **F.FWD** button.

Next, press the **PLAY** button or the **STOP** button repeatedly until the desired day appears. Then, press the **F.FWD** button.

The day of the week will appear automatically. You can not program the VCR to record more than one year in advance.

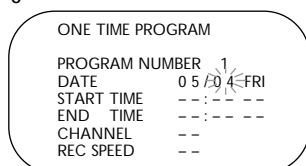

5

Enter the recording's start time.

Press the **PLAY** button or the **STOP** button repeatedly until the desired hour appears. Press the **F.FWD** button.

Press the **PLAY** button or the **STOP** button repeatedly until the desired minute appears. Press the **F.FWD** button.

Finally, press the **PLAY** button or the **STOP** button to point to **AM** or **PM**. **AM** or **PM** will flash beside the time. Press the **F.FWD** button.

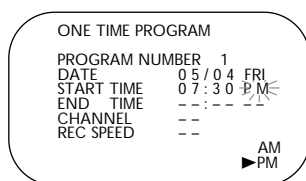

6

Repeat the procedure in step 5 to set the recording's end time.

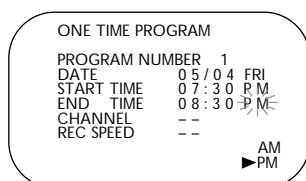

Instructions continue on page 28.

4-6

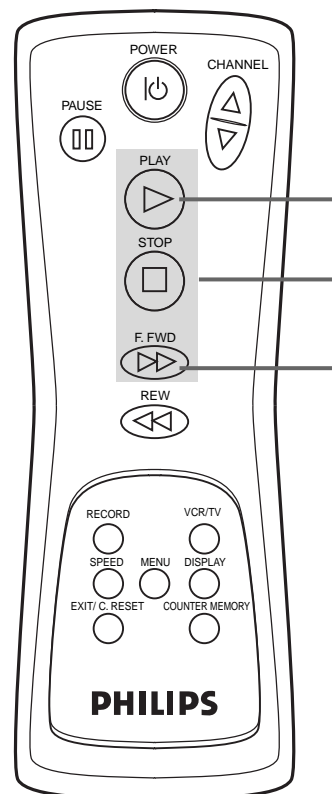

Helpful Hints

- Press the **REW(ind)** button to go back one step from the current step during steps 2-8.
 - To stop a started timer recording, press the **STOP/EJECT** button on the VCR.
- More Helpful Hints are on page 38.**

28 Timer Recording (cont'd)

7

Press the **PLAY** button or the **STOP** button repeatedly until the desired channel number appears. Then, press the **F.FWD** button.

- If you are using a standard antenna/cable hookup (as shown on page seven), select the channel of the TV program you want to record.
- If you are recording from line input, select L1. (LineIn Rear (L1) is located at the channel 00.) You should have the VCR connected to other video equipment. *Details are on page 32.*
- If you are using a Cable Box/DBS, select the Cable Box/DBS output channel (03 or 04). Select the channel you want to record at the Cable Box/DBS. Leave the Cable Box/DBS on for the timer recording. *Details are on page eight.*

```
ONE TIME PROGRAM
PROGRAM NUMBER  1
DATE            05 / 04  FRI
START TIME     07 : 30 P M
END TIME       08 : 30 P M
CHANNEL        16
REC SPEED      --
```

8

Press the **PLAY** button or the **STOP** button repeatedly to select a tape speed. The arrow will appear beside your choice. The selected tape speed will flash beside REC SPEED.

```
ONE TIME PROGRAM
PROGRAM NUMBER  1
DATE            05 / 04  FRI
START TIME     07 : 30 P M
END TIME       08 : 30 P M
CHANNEL        16
REC SPEED      SP
```

9

Press the **EXIT/C.RESET** button.

10

Press the **POWER** button to turn off the VCR. The **TIMER** light will appear. (The **TIMER** light will flash if there is not a tape in the VCR.)

If a timer recording will take place several hours or days from now, you may use the VCR until time for the timer recording. Just make sure you turn off the VCR about five minutes before the scheduled start time.

**Turn off the VCR for the recording.
Insert a tape in the VCR.
Leave the Cable Box/DBS on
(if applicable).**

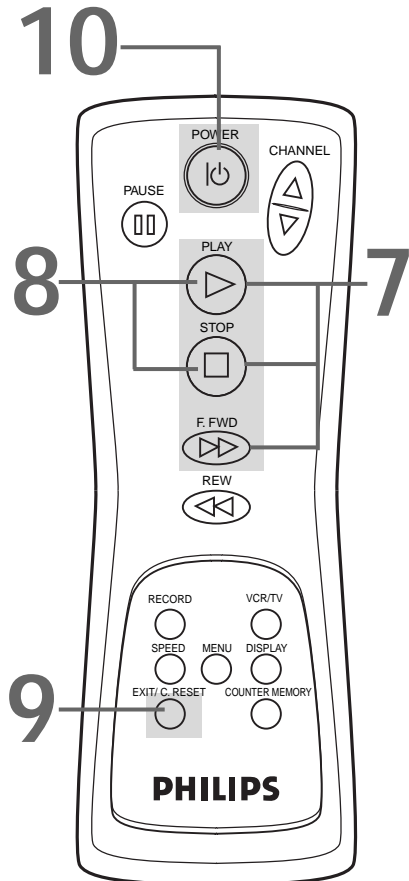

..... Cancelling a Timer Recording

1

Press the **MENU** button so that the details of your program appear on the screen. If there are no recordings set, the main menu will appear.

TIMER PROGRAMMING		
DATE	STA/END	CH
▶ 1 05/04	07:30 PM	16
FRI	08:30 PM	SP
3 05/11	10:00 PM	125
W FRI	10:54 PM	SLP
5 05/21	11:00 PM	40
DAILY	11:30 PM	SLP

2

Press the **PLAY** button or the **STOP** button to select the program number you want to cancel.

3

Press the **F.FWD** button.

ONE TIME PROGRAM		
PROGRAM NUMBER	01	FRI
DATE	05/04	PM
START TIME	07:30	PM
END TIME	08:30	PM
CHANNEL	16	
REC SPEED	SP	

4

While the program number is flashing, press the **REW(ind)** button to cancel the timer recording.

5

Press the **EXIT/C.RESET** button when you are finished.

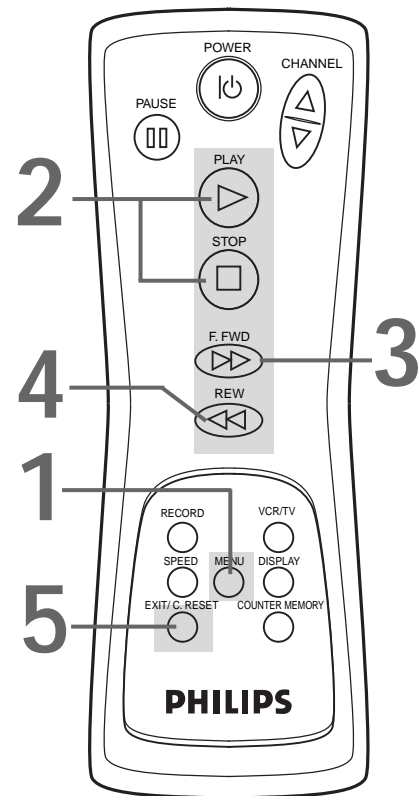

30 Timer Recording (cont'd)

Correcting a Timer Recording

If you need to correct a timer recording after you have finished setting the program, follow these steps. Make sure the VCR is on and is in VCR position. (The VCR/TV light will appear. If it does not, press the VCR/TV button once.)

1

Press the **MENU** button so that the details of your programs appear on the screen. If there are no recordings set, the main menu will appear.

TIMER PROGRAMMING		
DATE	STA/END	CH
▶ 1 05/04	07:30 PM	16
FRI	08:30 PM	SP
3 05/11	10:00 PM	125
W FRI	10:54 PM	SLP
5 05/21	11:00 PM	40
DAILY	11:30 PM	SLP

2

Press the **PLAY** button or the **STOP** button to select the timer recording you want to correct.

3

Press the **F.FWD** button.

ONE TIME PROGRAM		
PROGRAM NUMBER	DATE	FRI
	05/04	FRI
START TIME	07:30	PM
END TIME	08:30	PM
CHANNEL	16	
REC SPEED	SP	

4

Select the information you want to change using the **F.FWD** button. Press the **REW(ind)** button to go back one step. (There is an exception. Do not press the **REW(ind)** button while the program number is flashing. If you do, you will cancel the timer recording completely.)

5

While the information is flashing, enter the correct information by pressing the **PLAY** button or the **STOP** button.

6

When all the information is correct, press the **EXIT/C.RESET** button. Turn off the VCR before the timer recording.

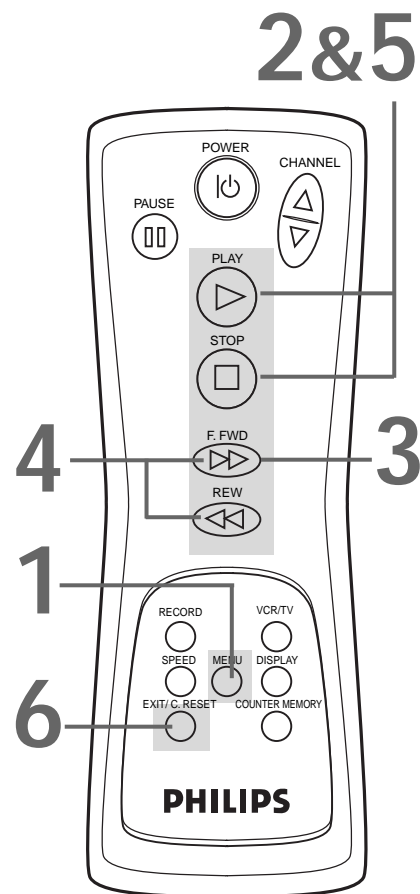

Recording One Channel/Watching Another 31

1

Press the **RECORD** button to start a recording of the current channel. *Details are on page 24.*

2

Press the **VCR/TV** button to put the VCR in TV position. The VCR/TV light will disappear.

3

Use the TV remote control to select the channel you want to watch at the TV.

4

To return to the channel being recorded, use the TV remote control to select channel 3 or 4, whichever channel the CH3/CH4 switch on the back of the VCR is set to.

5

Press the **VCR/TV** button on the VCR remote control to put the VCR in VCR position. The VCR/TV light will appear. The channel being recorded will appear on the screen.

6

To stop recording, press the **STOP** button.

3

Select the channel you want to watch at the TV.

4

Set the TV to channel 3 or 4.

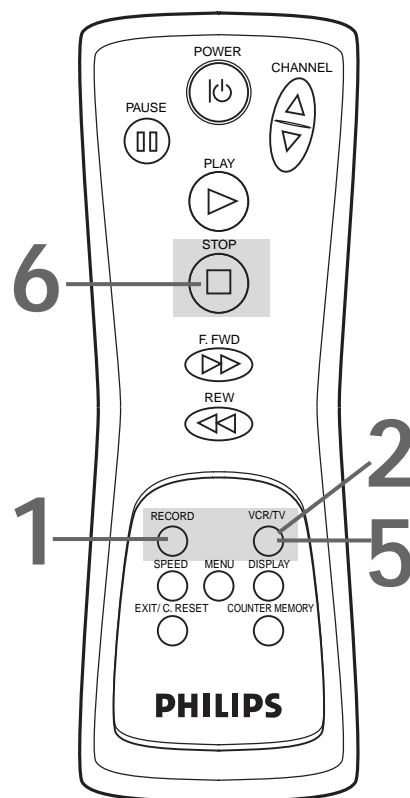

Helpful Hint

- If you use a Cable Box/DBS, you may not be able to watch one channel while recording another. *Details are on pages eight-nine.*

32 Rerecording (Copying Tapes)

1. Audio cable from AUDIO OUT Jack of VCR 1 to AUDIO IN Jack of VCR 2

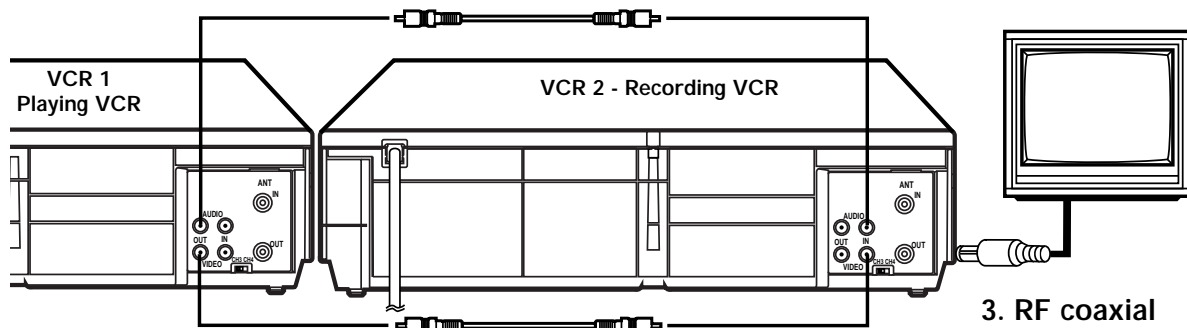

2. Video cable from VIDEO OUT Jack of VCR 1 to VIDEO IN Jack of VCR 2

3. RF coaxial cable from the OUT jack of VCR2 to the TV's ANTENNA IN Jack

1

VCR 1 will play your tape. Insert a prerecorded tape in VCR 1. If the tape does not have a record tab, playback begins. If this happens, press the STOP/EJECT button on VCR 1 once.

2

VCR 2 will record your tape. Insert a blank tape in VCR 2. Make sure the record tab is intact (details are on page five). Make sure the VCR 2 power is on and VCR 2 is in VCR position. (The VCR/TV light will appear. If it does not, press the VCR/TV button once.)

3

Turn on the TV and set it to channel 3 or 4, whichever channel the CH3/CH4 switch on VCR 2 is set to.

4

Point the remote control at VCR 2. Press the CHANNEL ▲/▼ buttons until LineIn Rear (L1) appears on the screen.

5

Point the remote control at VCR 2. Use the SPEED button to select SP or SLP.

6

Press the PLAY button on VCR 1 and the RECORD button on VCR 2 at the same time.

7

To stop recording, press the STOP/EJECT button on VCR 2 once, then stop the tape on VCR 1.

Helpful Hints

- Unauthorized recording of copyrighted television programs, video tapes, or other materials may infringe on the rights of copyright owners and violate copyright laws.
- If a program has copyright protection, it may not record clearly.
- Audio and video cables are not supplied.
- The illustration uses two VCRs just like yours. Different VCRs may operate differently.
- When LineIn Rear (L1) appears on the screen, the screen will be blue.

Repeat Play 33

Follow the steps below to make the VCR play a tape over and over. Make sure:

- The VCR is on and is in VCR position. The VCR/TV light will appear on the front of the VCR. If it does not, press the VCR/TV button once.
- There is a tape in the VCR.

1

Press the **MENU** button until the main menu appears.

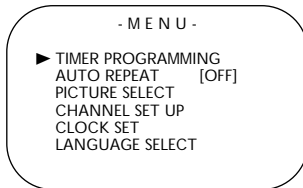

2

Press the **PLAY** button or the **STOP** button repeatedly to select **AUTO REPEAT**.

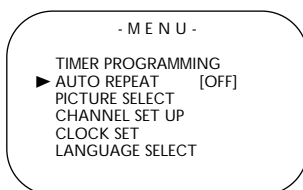

3

Press the **F.FWD** button so that **[ON]** appears next to **AUTO REPEAT**. Tape playback will begin immediately. **AUTO REPEAT ▶** will appear on the screen briefly.

(If you are fast forwarding or rewinding the tape, you must first press the **EXIT/C.RESET** button, then press the **PLAY** button to begin tape playback.)

The VCR will play the tape to the end, rewind it, then play it again. (TV programming will appear on the screen while the tape is rewinding.)

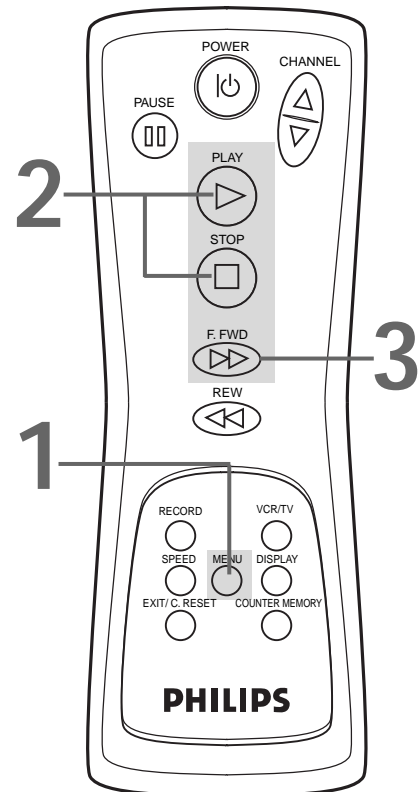
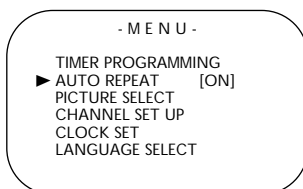

Helpful Hints

- To cancel **AUTO REPEAT**, follow steps 1-2 above. At step 3, press the **F.FWD** button so that **[OFF]** appears beside **AUTO REPEAT**. Press the **EXIT/C.RESET** button.
- The **COUNTER MEMORY** button does not work if **AUTO REPEAT** is set to **[ON]**.
- The real-time counter memory is cancelled if **AUTO REPEAT** is set to **[ON]**.

34 Forward and Reverse Searching/Pausing a Picture

Forward and Reverse Searching (SP/LP/SLP)

1

During tape playback, press and release the F.FWD button or the REW(ind) button. A fast forward or reverse picture search will begin.

2

To return to playback, press the PLAY button.

Super High Speed Searching (LP/SLP)

1

During tape playback, press the F.FWD button or the REW(ind) button, then press again. The VCR will now search in super high speed.

2

To return to playback, press the PLAY button.

Pausing a Picture

1

During tape playback, press the PAUSE button. A paused picture will appear on the screen.

NOTE : Only tapes recorded in SLP (Super Long Play) speed will show a clear picture. Each time you press the PAUSE button, the noise lines will change position on the screen.

2

To release the paused picture and return to normal playback, press the PLAY button.

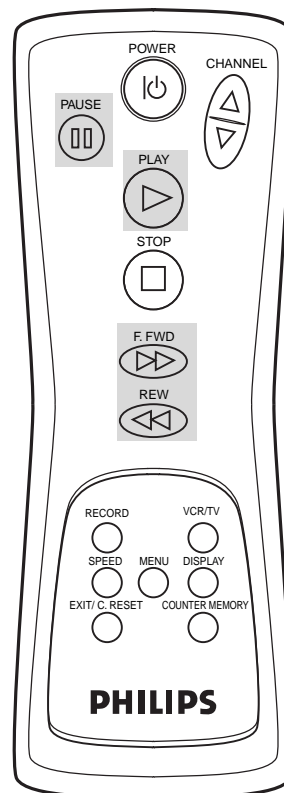

Helpful Hints

- A paused picture will automatically switch to Stop mode after five minutes to protect the VCR and the tape from damage.
- SP/LP/SLP means this feature will work with tapes recorded in Standard Play, Long Play, or Super Long Play.
- LP/SLP means this feature will work with tapes recorded in Long Play or Super Long Play. For details about tape speed, see page 42.

Picture Select 35

You can select the picture quality of a tape.

Make sure:

- The VCR is on and is in VCR position. The VCR/TV light will appear. If it does not, press the VCR/TV button once.
- There is a tape in the VCR.

1

During tape playback, press the MENU button until the main menu appears.

- M E N U -

- ▶ TIMER PROGRAMMING
- AUTO REPEAT [OFF]
- PICTURE SELECT
- CHANNEL SET UP
- CLOCK SET
- LANGUAGE SELECT

2

Press the PLAY button or the STOP button repeatedly to select PICTURE SELECT. Then, press the F.FWD button.

- M E N U -

- TIMER PROGRAMMING
- AUTO REPEAT [OFF]
- ▶ PICTURE SELECT
- CHANNEL SET UP
- CLOCK SET
- LANGUAGE SELECT

3

Within five seconds, press the F.FWD button until your desired mode (NORMAL, SOFT, or SHARP) appears on the screen.

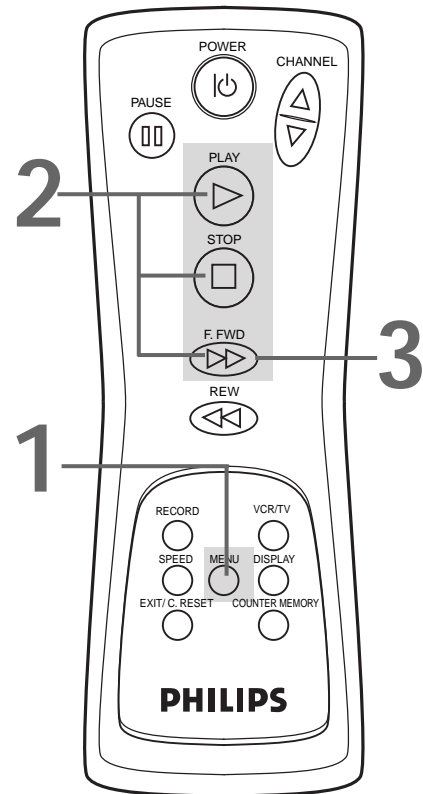

Helpful Hint

- You may only change the Picture Select setting during tape playback.

36 Real-Time Counter Memory

Follow the steps below to reset the real-time counter to zero at a tape location you want to refer to later. Make sure:

- The VCR is on and is in VCR position. The VCR/TV light will appear. If it does not, press the VCR/TV button once.
- There is a tape in the VCR.

1

Play, fast forward, or rewind a tape to the location that you would like to refer to later. **Press the STOP button to stop the tape.**

2

Press the EXIT/C.RESET button repeatedly to reset the real-time counter to zero.

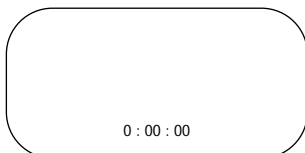

3

Within five seconds, press the COUNTER MEMORY button so that M appears on the screen beside the real-time counter.

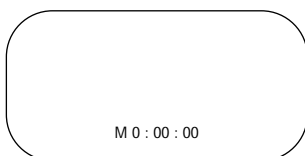

4

To go to a tape location where the real-time counter was reset to zero, press the REW(ind) button or the F.FWD button when playback is stopped.

When the tape reaches the point at which the real-time counter was reset to zero, the tape will stop.

Press the PLAY button to watch the tape.

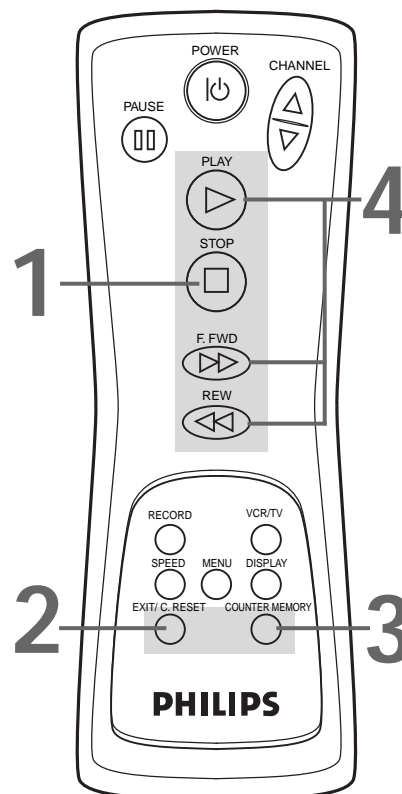

Helpful Hints

- You may only set the real-time counter memory at one location at a time. If you set the real-time counter to zero at a second location, the previous real-time counter to zero setting will be erased.
- To erase the real-time counter memory, press the COUNTER MEMORY button repeatedly so that the M disappears from the screen.
- The COUNTER MEMORY button does not function if AUTO REPEAT is set to [ON]. Details are on page 33.

Automatic Playback Features 37

Automatic Playback

When you put a tape in the VCR, the power will come on automatically. If the tape's record tab is missing, playback will begin. (If a timer recording is set, you may have to press the POWER button to turn on the VCR. Make sure you turn off the VCR for the timer recording later. If you insert a tape without a record tab when a timer recording is set, the VCR will eject the tape.)

Automatic Rewind, Eject, Off

When a tape is played, fast forwarded, or recorded to its end, the VCR will rewind the tape to the beginning, eject the tape, and turn itself off.

If the real-time counter memory is set, the VCR will only rewind the tape to the point at which the counter is set to zero, then stop. The VCR will not eject the tape or shut itself off.

Tape Eject

A tape can be ejected with the VCR power on or off (but the VCR must be plugged in). If a Timer Recording is programmed, a tape can only be ejected with the power on. Be sure to insert a tape for the Timer Recording, then turn off the VCR power.

Automatic Tracking Adjustment

The VCR automatically adjusts tracking to give you the best possible picture quality. With some recordings, however, you may get a better picture using the manual tracking controls (see below).

Manual Tracking

To adjust the tracking manually, press the CHANNEL ▲/▼ buttons **on the VCR** during playback.

NOTES:

- Tracking is returned to automatic tracking adjustment when a tape is inserted or when the STOP button is pressed to halt playback.
- Manual tracking will not change a paused picture.
- Use the CHANNEL ▲/▼ buttons on the VCR or on the remote control to remove vertical jitter in a Paused picture.

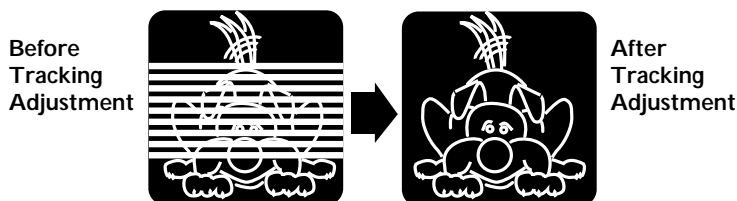

38 Helpful Hints

If you are having problems with your product, check this list of problems and possible solutions before requesting service. You may be able to solve the problem yourself.

If you need to call a customer service representative, please know the model number and serial number of your product before you call. This information is displayed on the back of the product. Also, please take a moment to identify the problem you are having, and be prepared to explain this to the representative. If you believe the representative will need to help you with operations, please stay near the product. Our representatives will be happy to assist you.

The VCR has no power.

- Make sure the power plug is completely connected to an AC (alternating current) outlet.
- Make sure the power is turned on.

A power failure occurred.

- Follow the steps on page 11 to select a language and set up channels, if necessary. Then, follow the steps on pages 14-15 to reset the VCR clock.
- Timer recordings may be lost if the power fails for more than one minute. Reprogram the timer recordings. *Details are on pages 26-30.*

The remote control will not operate the VCR.

- Aim the remote control directly at the VCR's remote sensor. *Details are on page 21.*
- Remove all obstacles between the remote control and the VCR.
- Inspect and/or replace the batteries in the remote control. *Details are on page five.*

The VCR does not respond normally to the remote control. (For example, the VCR may change channels multiple times when you press the CHANNEL ▲ button once.)

- Install new batteries (preferably alkaline) in the remote control.

The motor (cylinder) rotates even when the VCR is in Stop mode.

- To enable the quick play mechanism, the cylinder will rotate for about five minutes. This is normal. The quick play mechanism switches the tape mechanism from Stop to Play in just one second.

A TV program cannot be recorded.

- Check the connections between the VCR, TV, antenna/cable, and Cable Box/DBS, if applicable. *Details are on pages seven-10.*
- Make sure the tape has a record tab. *Details are on page five.*

The VCR will not perform a timer recording.

- Make sure the recording start and stop times are set correctly. *Details are on pages 26-30.*
- Make sure a tape is in the VCR and the tape has a record tab. *Details are on page five.*
- Make sure the VCR power is off.
- Make sure the VCR's internal clock is set. *Details are on pages 14-15.*
- The VCR may not perform or continue a timer recording if a power interruption of more than one minute occurs before or during the timer recording, even if the power comes back on afterward. Set up channels and reset the clock before re-programming the timer recording(s).
- Finish programming a timer recording at least five minutes before the recording is scheduled to begin.
- If, after programming a timer recording, you turn off the VCR without inserting a tape, the TIMER light will blink. Insert a tape with the record tab intact.
- Noon is 12 p.m. Midnight is 12 a.m.
- If the tape runs out before the recording ends, the VCR will stop, eject the tape, and turn itself off. The TIMER light will blink.
- If a tape without a record tab is inserted (when the power is off for a timer recording), the VCR will eject the tape. The TIMER light will blink. Insert a tape that allows recording.
- If the preset time for a timer recording comes up during a One-Touch Recording, the OTR has priority.
- When two timer recordings overlap, the timer recording with the earliest start time will have priority. When the earliest program has finished recording, the next program number will begin recording.

Tape cannot be removed.

- Make sure the power plug is completely connected to an AC (alternating current) outlet.
- You have set a timer recording. Turn on the VCR power, then eject the tape. Be sure to insert a tape and turn off the VCR for your timer recording.

Tape cannot be inserted.

- Insert the tape, window side up, with the record tab facing you.
- Make sure a tape isn't already in the VCR by pressing the STOP/EJECT button on the VCR.
- Gently push on the center of the tape when putting it in the VCR. Never force the tape into the VCR.
- If a timer recording is set, the VCR will not accept a tape that does not have a record tab. You may only insert a tape with the record tab intact.

VCR ejects the tape when the RECORD button is pressed or when the VCR power is turned off to set a timer recording.

- Make sure the tape has a record tab. *Details are on page five.*

There is no playback picture, or the playback picture is noisy or contains streaks.

- Make sure the TV is on the same channel as the VCR's CH3/CH4 switch. *Details are on page seven.*
- Make sure the VCR is in VCR position. (The VCR/TV light will appear. If it does not, press the VCR/TV button once.)
- Make sure channel 3 or 4 is properly adjusted.
- Adjust the tracking. *Details are on page 37.*
- TVs placed too close to the VCR can cause interference during tape playback. Move the VCR away from the TV.

TV programs cannot be watched normally.

- Press the VCR/TV button to put the VCR in TV position. (The VCR/TV light will disappear.)
- Check the connections between the VCR, TV, antenna/cable, and Cable Box/DBS (if applicable). *Details are on pages seven-10.*

The reception on all channels is poor.

- You may need to tune your TV again.

Line Input

- If you accidentally enter Line Input mode (LineIn Rear (L1) will appear on your TV screen briefly), press the CHANNEL ▲/▼ buttons to select another channel.

The playback picture is too dim, too bright, or fluctuates in brightness.

- Some programs may be broadcast with copyright protection technology in order to protect the rights of copyright owners. This technology is used on programs that are recorded on video tapes or Digital Video Discs (DVDs), as well as some programs broadcast by antenna/cable/satellite television channels. Programs broadcast with copyright protection technology may not record clearly. Likewise, if you play a tape that is a recording of a copyright protected program, the picture may not be clear. Tapes of copyright protected programs may have a picture that is dark or dim, or the brightness of the picture may fluctuate. Therefore, you should avoid recording or playing copies of copyright protected programs. This VCR incorporates copyright protection technology that is protected by method claims of certain U.S. patents and other intellectual property rights owned by Macrovision Corporation and other rights owners. Use of this copyright protection technology must be authorized by Macrovision Corporation and is intended for home and other limited viewing uses only, unless otherwise authorized by Macrovision Corporation. Reverse engineering or disassembly is prohibited.

**RENEWED
90 DAY
LIMITED WARRANTY**

41 Dictionary/Specifications

Dictionary

AUDIO IN/OUT Jacks: jacks located on the back of the VCR which are used to record audio from another source (IN) or to send audio to another system (OUT).

Automatic Channel Setup: process in which the VCR scans all available TV channels and places the ones you receive in its memory. Then, when you push the CHANNEL ▲/▼ button, you only scan through channels you receive.

Bands: settings that allow you to tune channels.

- **Antenna** – VHF (very high frequency; channels 2-13) and UHF (ultra high frequency; channels 14-69).
- **Cable** – all standard channels can be received without a Cable Box/DBS.

Cable Box/DBS Output Channel: Channel 3 or 4.

Dubbing: copying a tape using a second VCR.

Frame: a single paused picture.

HQ: high quality; a feature in the VCR that provides a better picture.

Line Input: The channel to which you set your VCR during dubbing. The line input channel is always channel 00.

If you accidentally enter Line Input mode (LineIn Rear (L1) will appear on your TV screen briefly), press the CHANNEL ▲/▼ button to select another channel.

Mode: a VCR operation.

OTR: One-Touch Recording; a recording that starts immediately and lasts for 30 minutes to eight hours, whichever you decide.

Remote Control: the small unit that came with your VCR; allows you to operate your VCR from a distance.

RF coaxial cable: The cable that came with your VCR. Use it to connect your VCR to your TV (or Cable Box/DBS, if applicable).

Special Effects: forward and reverse searching; a frozen (paused) picture.

Tape Speeds: how fast the tape travels during a recording or during playback. The slower the tape speed, the more you can record on a tape.

- SP (standard play) – fastest tape speed (recording time for a T120 tape is approximately two hours); best picture quality.
- LP (long play) – average tape speed; playback only.
- SLP (super long play) – slowest tape speed (recording time for a T120 tape is approximately six hours).

VCR: video cassette recorder.

VIDEO IN/OUT Jacks: jacks located on the back of the VCR which are used to record video from another source (IN) or to send video to another system (OUT).

Specifications

Video Heads

Two heads

Video Signal

EIA standards; NTSC color

Antenna

VHF/UHF – 75 ohm external antenna terminal

VHF Output Signal

Channel 3 or 4 (switchable)
75 ohms unbalanced

Power Requirement

120V AC; 60Hz

Power Consumption

12W

Operating Temperature

41°F (5°C) to 104°F (40°C)

Relative Humidity

10% to 80%

Weight

5.3 lbs. (2.4 kg.)

Dimensions

14-3/16" (W) x 3-5/8" (H) x 8-3/4" (D)
(360 mm x 92mm x 223mm)

Tuner Broadcast Channels

VHF 2-13, UHF 14-69

Cable TV Channels

1-125

NOTE: Designs and specifications are subject to change without notice.

<p>ac power cord7, 22</p> <p>accessories.....43</p> <p>alarm clock.....6, 20</p> <p>ant(enna) in jack7-10, 22</p> <p>audio in/out jacks10, 22, 32, 41</p> <p>automatic</p> <p style="padding-left: 20px;">playback.....37</p> <p style="padding-left: 20px;">rewind, eject, off37</p> <p>back panel22</p> <p>batteries.....5</p> <p>cassette compartment20</p> <p>ch3/ch4 switch.....7-9, 22</p> <p>channel</p> <p style="padding-left: 20px;">adding.....13</p> <p style="padding-left: 20px;">deleting.....13</p> <p style="padding-left: 20px;">setup.....11, 12</p> <p style="padding-left: 20px;">▲/▼ buttons.....19, 21, 37</p> <p>clock holder (alarm clock)6</p> <p>clock (VCR) on-screen display...17</p> <p>clock (VCR).....14-15</p> <p>connections.....7-10, 32</p> <p>contents, table of4</p> <p>controls</p> <p style="padding-left: 20px;">remote.....18-19</p> <p style="padding-left: 20px;">vcr.....20-22</p> <p>copying tapes.....32</p> <p>copyright protection32, 39</p> <p>count on-screen display17</p> <p>counter memory button19, 36</p> <p>cst. in light.....20</p> <p>dictionary41</p> <p>display button17-18</p> <p>display panel20</p> <p>erasure prevention5</p> <p>exit/c.reset button19, 36</p> <p>f.fwd button.....19, 21</p> <p>front panel21</p> <p>helpful hints38-39</p> <p>hookups</p> <p style="padding-left: 20px;">for copying tapes.....32</p> <p style="padding-left: 20px;">with a cable box/dbs.....8-9</p> <p style="padding-left: 20px;">with a stereo tv.....10</p> <p style="padding-left: 20px;">without a cable box/dbs7</p> <p>language selection11, 16</p> <p>line input mode.....32, 41</p> <p>long play41</p> <p>lp41</p>	<p>menu button.....18</p> <p>on-screen displays.....17</p> <p>one-touch recording25</p> <p>out jack7-9, 22, 32</p> <p>pause button.....19, 21, 24, 34</p> <p>paused picture34</p> <p>picture select.....35</p> <p>play button.....18, 21, 23, 34</p> <p>playing23</p> <p>power</p> <p style="padding-left: 20px;">button18, 21</p> <p style="padding-left: 20px;">cord7, 22</p> <p style="padding-left: 20px;">light.....20</p> <p>rec(ord) light20</p> <p>record button18, 21</p> <p>record tab5</p> <p>recording</p> <p style="padding-left: 20px;">basic.....24</p> <p style="padding-left: 20px;">one channel/watching another ..31</p> <p style="padding-left: 20px;">prevention.....5</p> <p style="padding-left: 20px;">timer26-30</p> <p>remote</p> <p style="padding-left: 20px;">control</p> <p style="padding-left: 40px;">buttons.....18-19</p> <p style="padding-left: 40px;">holder5</p> <p style="padding-left: 40px;">using.....18</p> <p style="padding-left: 20px;">sensor21</p> <p>repeat play33</p> <p>rerecording.....32</p> <p>rew(ind) button18, 21, 34</p> <p>rf coaxial cable7-9, 32, 41</p> <p>safety precautions3</p> <p>searching forward/reverse34</p> <p>sensor (remote)21</p> <p>slp.....41</p> <p>sp.....41</p> <p>specifications41</p> <p>speed button18</p> <p>standard play41</p> <p>stop button.....19</p> <p>stop/eject button.....21</p> <p>super long play.....41</p> <p>table of contents4</p> <p>tape</p> <p style="padding-left: 20px;">copying.....32</p> <p style="padding-left: 20px;">eject.....21, 37</p> <p style="padding-left: 20px;">speed.....41</p> <p style="padding-left: 20px;">time (VCR)14-15</p> <p>timer</p> <p style="padding-left: 20px;">light.....20</p> <p style="padding-left: 20px;">recording</p> <p style="padding-left: 40px;">cancelling.....29</p> <p style="padding-left: 40px;">correcting.....30</p> <p style="padding-left: 40px;">setting.....26-28</p> <p>tracking.....37</p> <p>tv</p> <p style="padding-left: 20px;">hookups7-10, 32</p> <p style="padding-left: 20px;">position.....19, 31, 39</p> <p>vcr position.....19</p> <p>vcr/tv button19</p> <p>vcr/tv light.....20</p> <p>video in/out jacks10, 22, 32, 41</p> <p>warranty.....40</p>
--	---

SUPPLIED ACCESSORIES

The following items are supplied with your VCR; they are provided to help you use or set up your VCR.

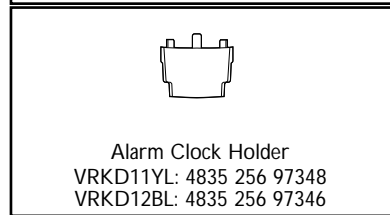
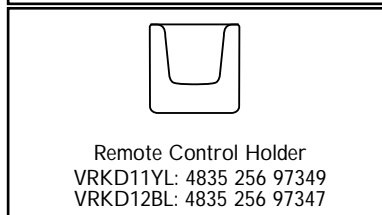
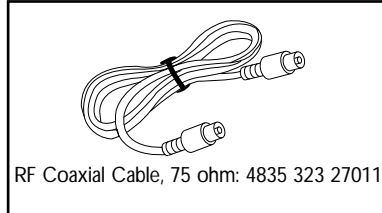

OPTIONAL ACCESSORIES

The following additional items are not provided with your VCR, but they are designed for use with your new VCR. To order these optional accessories, contact us at:

Philips Parts & Accessories Marketing Department
401 East Old Andrew Johnson Highway
P.O. Box 555
Jefferson City, TN 37760
1-800-851-8885.

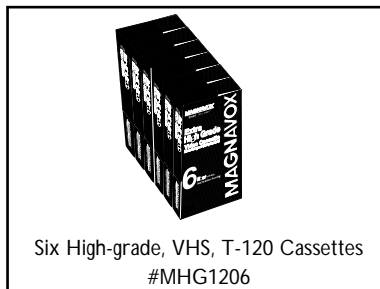
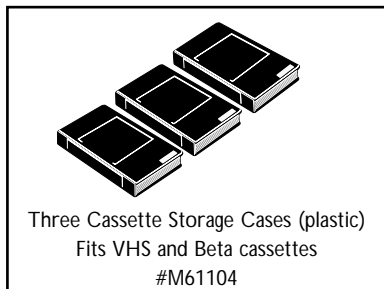
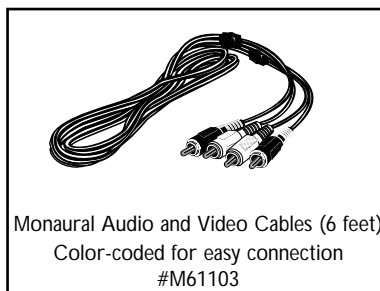

This instruction book is made of recyclable materials.
Remember to recycle!



As an ENERGY STAR® Partner, Philips Consumer Electronics Company has determined that this product meets the ENERGY STAR® guidelines for energy efficiency. ENERGY STAR® is a U.S. registered mark.

IB8245E001
Printed In China
0VMN02574/H57V0UD, H57V1UD *****

Free Manuals Download Website

<http://myh66.com>

<http://usermanuals.us>

<http://www.somanuals.com>

<http://www.4manuals.cc>

<http://www.manual-lib.com>

<http://www.404manual.com>

<http://www.luxmanual.com>

<http://aubethermostatmanual.com>

Golf course search by state

<http://golfingnear.com>

Email search by domain

<http://emailbydomain.com>

Auto manuals search

<http://auto.somanuals.com>

TV manuals search

<http://tv.somanuals.com>