



Subwoofer Owner's Manual:

Rhino-Ten

Rhino-Twelve

Rhino-Fifteen

© 2009 PINNACLE LOUDSPEAKERS

We congratulate and thank you for choosing a PINNACLE® subwoofer. Our subwoofers exemplify the best in modern audio technology, and are designed to produce remarkable amounts of deep bass. Please read this manual completely to ensure the best possible performance from your Home Theater or sound system.

SOLID BRASS ISOLATION CONES:

Please make sure to install the Solid Brass Isolation Cones into the bottom of your subwoofer cabinet. They are an important part of the performance of the product and will improve the bass definition.

With the cabinet on its side, simply screw the cones into their receptacles on the bottom of the cabinet. Then, with the cabinet upright, adjust the cones individually as needed to level the cabinet. When the cones have been adjusted to the proper height, screw each nut up the threaded shaft flush with the bottom of the cabinet to secure the height setting. If you intend to place your subwoofer on wooden or vinyl floors, we suggest placing a penny under each cone to prevent any indentations.

PLACEMENT:

Recommended Subwoofer Placement:

- a) Within a few inches of the room corner closest to your left or right front speaker (maximum low bass output);
- b) Against the wall between your left and right front speakers (strong low bass output with optimal blending to front speakers);
- c) Near any other room corner or wall.

Other locations will provide varying degrees of low bass impact and blending with your front speakers. We recommend listening to your system, with the subwoofer in different room positions, to obtain a location with an optimum response. Please be sure to leave at least ~2-3" between the rear woofer and your wall.

If you must place your subwoofer near baseboard heaters or forced hot air vents try to leave at least 4" of clearance for proper ventilation. Do not place your subwoofer outdoors, or in any wet or excessively damp environment.

Note: If you have an older, non-flat screen TV, please place your subwoofer far enough away from your TV (approximately 2-3 feet) to avoid any color distortion from being caused by your subwoofer's powerful magnet. If you experience picture distortion, simply move the subwoofer away from the TV until the picture becomes distortion free. We also recommend keeping magnetic media such as audio/videotapes and computer disks at least 2-3 feet away from your subwoofer to prevent damaging them.

CONNECTIONS:

Complete all wire connections in your Home Theater / sound system before powering up your subwoofer or your receiver (amplifier). Be sure to observe proper polarity for all speaker wire connections (+ to +, - to -). To obtain the best performance, use only speaker wire of 12, 14, or 16 gauge (available from your dealer). Lightweight speaker wire (18, 20, 22 gauge, etc.) will result in degraded performance; 16 gauge wire may be used for short runs of about 8 feet or less.

CONNECTION OPTION #1 - Using The Line Input(s):

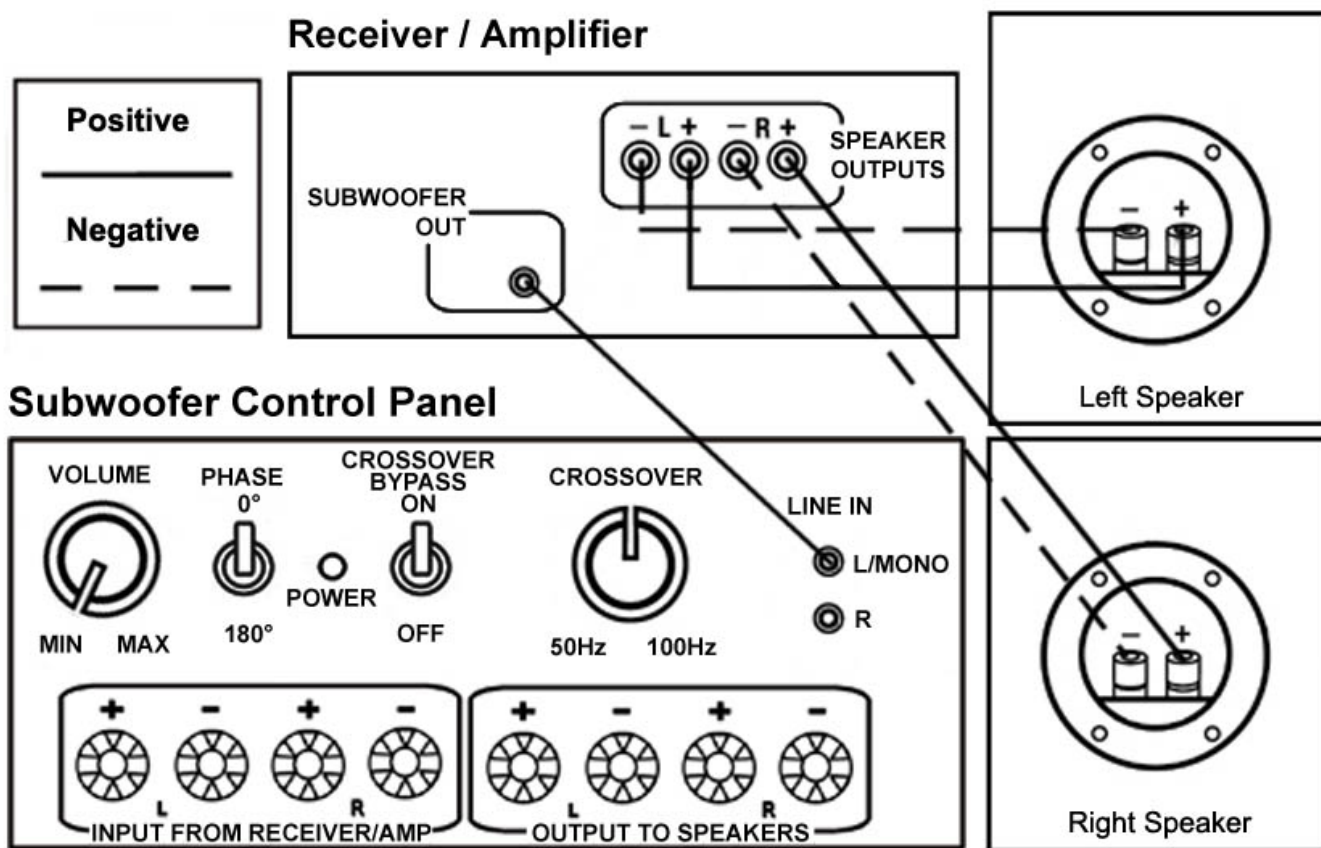

To use the subwoofer's LINE INPUT(s) your receiver must have a dedicated "subwoofer output" jack (sometimes called Sub Out, Low Pass or LFE), or pre-amp left & right channel outputs. If your receiver has these outputs you may connect your subwoofer using standard (coaxially shielded) RCA cable(s) (the same kind of audio cable used to connect your CD, tape deck, etc.). This method is generally the easiest to hook-up.

- If your receiver has a subwoofer output jack, simply connect your subwoofer, using the L / Mono Line Input jack, to the subwoofer output jack on your receiver (refer to the Option #1 wiring diagram above).

- If your receiver has no subwoofer output jack but has pre-amp left & right channel outputs you can connect your subwoofer directly to your receiver's pre-amp outputs using the L & R Line Input jacks. If your receiver uses jumpers to connect its pre-amp outputs with its amp stage inputs you will need to acquire two splitter cables (such as Radio Shack #42-2535) to be able to hookup your sub while continuing to provide a signal to your receiver's amp stage inputs. Note: Do not connect your subwoofer to the tape loop outputs from your receiver as they will overdrive its circuitry!
- If you have a Dolby Digital or DTS receiver place the subwoofer's Crossover Bypass switch in the ON position (this bypasses the Low Pass Filter in the subwoofer). If you do not have a Dolby Digital or DTS receiver place the subwoofer's Crossover Bypass switch in the OFF position (this activates the Low Pass Filter in the subwoofer).
- Lastly, wire your left and right front speakers directly to your receiver's speaker outputs. Please refer to the Option #1 wiring diagram for further clarification.

CONNECTION OPTION #2 - Using The Binding Post Inputs:

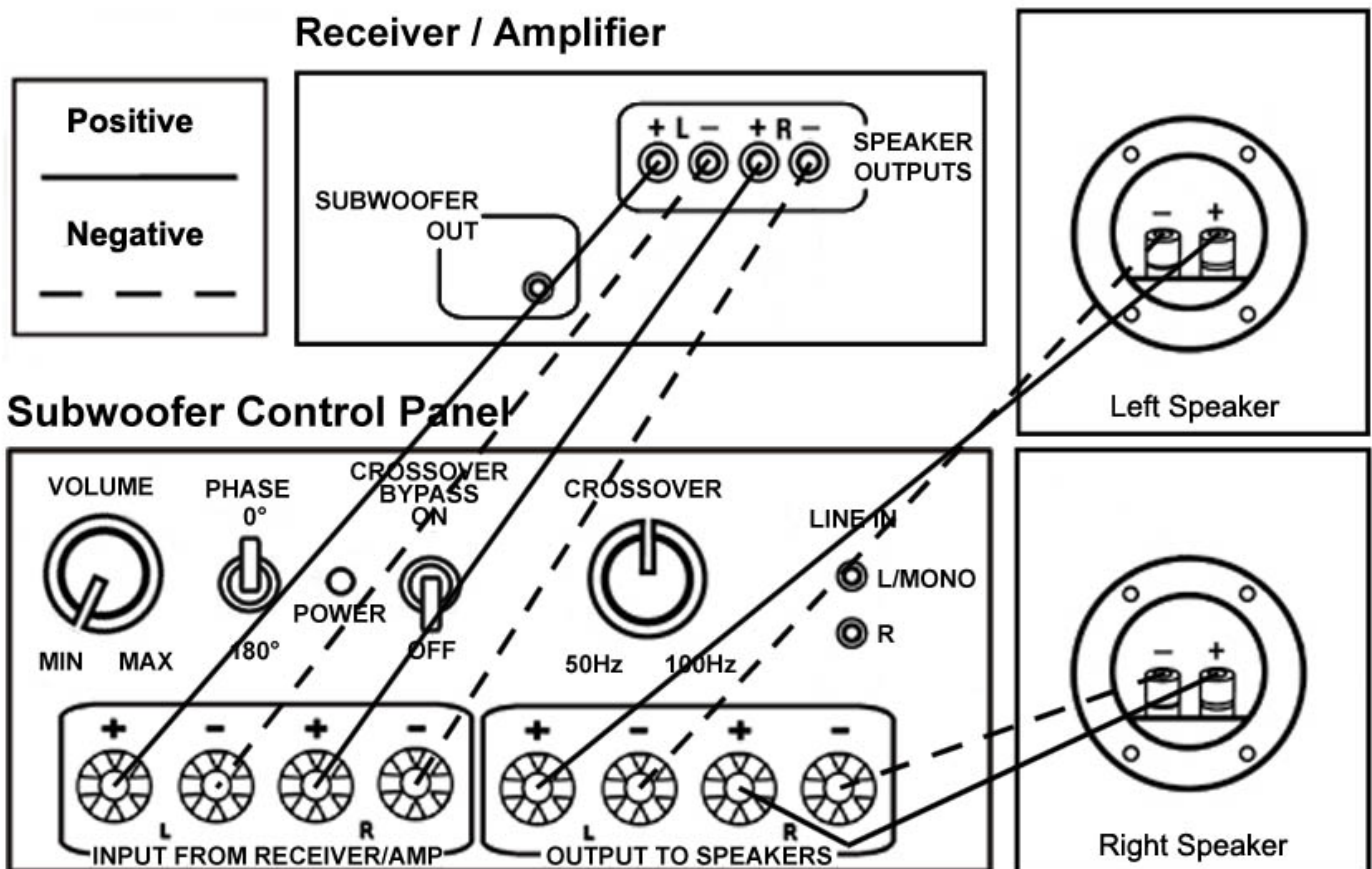

There are two reasons to use this connection option. The first is if your receiver has no subwoofer output jack! The second is if your system would benefit from having the bass filtered out of the main speakers (if you have a Dolby Digital or DTS receiver you can achieve the same results electronically simply by configuring your main speakers as SMALL and connecting your sub using an RCA cable - see Connection Option #1). If you have large main speakers that are capable of reproducing a great deal of bass on their own then this connection option may not be advantageous to you. If however you have small main speakers then this method deserves consideration. Since this connection method filters out the low bass from the main speakers it provides the beneficial effects of increasing their power handling and improving their clarity.

If you choose to use this connection option, simply run speaker wire from your receiver's speaker outputs to the subwoofer inputs marked "Input From Receiver / Amp". Then, wire your left and right front speakers to the subwoofer outputs marked "Output To Speakers". Please refer to the Option #2 wiring diagram for further clarification. Place the Crossover Bypass Switch on the subwoofer in the OFF position (this activates the Low Pass Filter).

POWER-UP AND TONE CONTROL ADJUSTMENTS:

- Plug your subwoofer into any ordinary wall outlet. Since your subwoofer can require up to 1600 Watts of power, do not plug the subwoofer into any outlet that cannot deliver 1600 Watts (like those on the back of other electronic equipment such as your receiver).
- With the VOLUME control at minimum (maximum counter-clockwise position), plug in the subwoofer's power cord and turn the power switch on the subwoofer's control panel to the ON position. The Auto-on circuitry will automatically turn the unit on (LED turns green) when it receives an audio signal. It will also automatically turn the unit off (LED turns red) after a few moments without any audio signals. If for any reason you do not want your subwoofer on, simply turn the power switch to the off position.
- Please ensure that your receiver's loudness control is off and that the bass tone control is in its middle (no boost) position. Now play some music with ample bass content. (The following setup routine is best accomplished with one person seated in a normal listening position directing another to adjust the controls for the best sound.)
- Adjust the VOLUME level on the subwoofer's control panel so that the output level of the subwoofer is satisfactory (relative to your front speakers). If either of your front speakers or subwoofer are not functioning properly, please refer to the Troubleshooting section toward the end of this manual.

- Adjust the PHASE switch on the subwoofer's control panel to determine which position sounds the most natural. The difference should be most audible in the mid-bass. If you cannot detect a difference, leave the PHASE switch in the 0° (in-phase) position.
- If you have placed your subwoofer's Crossover Bypass switch in the OFF position adjust the CROSSOVER knob and determine what position sounds best. This feature controls the output level of the mid and upper bass frequencies. Please note that if you have put your subwoofer's Crossover Bypass switch in the ON position, due to the low pass filter already in your receiver, the subwoofer's crossover control is unnecessary, will have no effect, and its position can therefore be ignored.
- The best VOLUME level, PHASE switch and CROSSOVER positions will mostly be determined by your room acoustics and the mid and upper bass frequency response characteristics of your front speakers. The source material will also play a significant role as its bass level may vary considerably.
- After your initial adjustments you may want to go back and "tweak" these controls. Their effects are acoustically interrelated. Re-adjusting them may be necessary to obtain optimal performance. Generally, once you are satisfied with your subwoofer's settings, you can use your receiver's tone, equalizer, volume and subwoofer output level controls to optimize your whole system's performance.

VERY IMPORTANT!

- **If you have a Dolby Pro-Logic Home Theater system, make sure that your receiver's center channel mode is in the NORMAL position. This will ensure that all low bass information is sent to your subwoofer.**
- **If you have a Dolby Digital or DTS Home Theater system, make sure that you have correctly configured your receiver's Bass Management System so that all of your speakers are properly categorized as either SMALL or LARGE (please note your receiver's terminology may differ). This will ensure that all appropriate low bass information is sent to your subwoofer. As a general rule, a speaker with an 8" or greater diameter woofer may be considered LARGE. Conversely, a speaker with a woofer less than 8" in diameter may be considered SMALL. Please note that the bass output of a dual woofer speaker could be comparable to that of a larger single woofer speaker. Example: A dual 6.5" woofer system would generally be considered LARGE since its woofer area approximates that of a single 10" woofer system.**

- **With high volume levels of certain types of signals, the subwoofer may be audibly strained. If you hear the subwoofer “breaking-up” or distorting, turn your receiver’s volume level down.**
- If you have any problems or questions please contact your PINNACLE[®] dealer for further assistance.

TROUBLESHOOTING:

No Sound only from Subwoofer - Please note that this subwoofer has a thermal protection feature which will attenuate, or shut off its amplifier, if it gets too hot; it will turn itself back on when it has cooled sufficiently. Otherwise: Check subwoofer power / volume settings and all connections. Ensure that the center channel mode on the receiver is in the NORMAL or SMALL position. If you have connected the subwoofer via RCA cable and if your receiver has a subwoofer on/off or variable subwoofer output level control, ensure that the subwoofer option is turned on and that the output level is at maximum. Make sure the RCA cable is connected to the receiver's subwoofer output and not the subwoofer input jack that some receivers have. If the problem persists, refer to the TO OBTAIN SERVICE section of your warranty at the end of this manual.

No Sound only from Left and Right Front Speakers - Check all connections. Ensure that your receiver's speaker channel A or B is switched on. Note: You must connect your speakers to your receiver's speaker outputs if you connected the subwoofer via the LINE INPUT(s).

Too Much Bass - Check: subwoofer volume / phase / crossover control positions; receiver bass / loudness controls; program material; move subwoofer further out of corner or away from wall.

Too Little Bass - Check: subwoofer volume / phase / crossover control positions; all speaker wire phase (+ to +, - to -); receiver tone controls; program material; ensure that the center channel mode on the receiver is in the NORMAL or SMALL position. If your receiver has a variable subwoofer output level control, ensure that the output level is at maximum. Try moving the subwoofer further into a corner or towards the wall. If you have connected the subwoofer via a single RCA cable you may want to try using a cable splitter (such as Radio Shack part #42-2535). This will allow you to use both line inputs which will increase the input signal strength to the subwoofer.

Rattling Noise: Tighten the binding posts on the sub's speaker level inputs & outputs. Check all four of the Solid Brass Isolation Cones to ensure they are making solid contact with the floor.

Hum: Check for faulty RCA connecting cable. Try to separate RCA cables from power cords (they can induce hum into the system). If that doesn't work we recommend you turn off your subwoofer when it is not in use. This is most easily accomplished by connecting its powercord to a switched power outlet.

BLACK RHINO SERIES PRODUCT SPECIFICATIONS:

Features:

High Power Digital Switching Amplifier With Anti-Clipping Circuit For High Level Undistorted Bass!
Fatboy Butyl Rubber Surrounds Enable High Excursion with Excellent Cone Control and Exceptional Durability
Auto On/Off circuit with LED indicator
Gold plated binding posts for a high quality and secure connection
Super Non-Resonant, Heavy Duty 1" Cabinet Construction
Heavy Duty 12 Gauge Internal Wiring For Maximum Bass Clarity
Line Level Inputs
Phase Switch
Satellite Speaker Crossover: First Order @ 80 Hz
Solid Brass Isolation Cones
Speaker Level Inputs & Outputs
Stylish Sculpted Cabinet Design
Crossover Bypass Switch
High Quality Detachable 2.5M IEC powercord
Designed and Assembled in the USA

System Type: Active / Passive Dual Driver System

Component Drivers:

Rhino-Ten: 10" heavyweight fibercone woofer with fatboy butyl surround, 3" voice coil & 68 ounce magnet
10" heavyweight fibercone passive radiator with fatboy butyl surround
Rhino-Twelve: 12" heavyweight fibercone woofer with fatboy butyl surround, 3" voice coil & 68 ounce magnet
12" heavyweight fibercone passive radiator with fatboy butyl surround
Rhino-Fifteen: 15" heavyweight fibercone woofer with fatboy butyl surround, 3" voice coil & 68 ounce magnet
15" heavyweight fibercone passive radiator with fatboy butyl surround

Subwoofer Low End Frequency Response: 30 Hz (- 3 dB)

Maximum SPL:

Rhino-Ten: 121 dB
Rhino-Twelve: 125 dB
Rhino-Fifteen: 127 dB

Variable Subwoofer Low Pass Filter: 50-100 Hz

Amplifier Power:

Rhino-Ten: 1400 Watts
Rhino-Twelve: 1600 Watts
Rhino-Fifteen: 1600 Watts

Dimensions:

Rhino-Ten: 13 5/16" Wide x 12" High x 12 15/16" Deep (with Amp & Baffle Covers)
Rhino-Twelve: 15 11/16" Wide x 14" High x 14 13/16" Deep (with Amp & Baffle Covers)
Rhino-Fifteen: 19 1/8" Wide x 17 3/16" High x 17 7/8" Deep (with Amp & Baffle Covers)

Finish: Textured Black Pebble Paint

Weight:

Rhino-Ten: 51 lbs.
Rhino-Twelve: 56 lbs.
Rhino-Fifteen: 71 lbs.

LIMITED WARRANTY:

What Is Covered

Your Pinnacle® subwoofer features a limited warranty as follows. The subwoofer driver(s) and all assembly and construction aspects are covered by this warranty for a period of seven (7) years from the date of original purchase. Your subwoofer amplifier is covered by this warranty for a period of two (2) years from the date of original purchase. The warranty covers all necessary parts and labor to return the subwoofer to proper working order. Cabinet surfaces, grille assembly, and other exterior parts subject to normal wear and tear are not covered except where an inherent structural defect becomes evident.

Parts replacement and labor will be performed at the discretion of Pinnacle Loudspeakers and will be provided free of charge unless (in the opinion of our service department, service representatives, or engineering department) the system has failed due to abuse or negligent operation.

What Is Not Covered

This warranty will be void and no free services performed if we or any party acting as our agent determines that the system has had any of its elements (amplifier, woofer, etc.) removed or tampered with in any way whatsoever. Furthermore, if your subwoofer is not found to be defective a service charge will be levied. In either case the minimum charge will be \$30.00. An additional charge will be applicable for same day service where possible and this charge will always be in effect even if the actual parts and labor are covered by this warranty. Pinnacle Loudspeakers reserves the right to make the final determination of whether or not the system has been damaged by abuse or negligent operation.

To Obtain Service

To obtain service under this warranty, either contact your Pinnacle® dealer or us directly at (516) 576-9052 or service@pinnaclespeakers.com. If you ship your subwoofer you are responsible for packing and shipping insurance. The freight must be prepaid. We will, however, pay return freight charges on any returned subwoofer that qualifies for in-warranty service. Sorry, we cannot accept any collect freight charges. You must include a note, attached to the unit, with your name, phone number or email address, and return shipping address (no Post Office boxes), indicating the nature of the problem you are experiencing. For warranty service you must also include a copy of your dated sales receipt. **YOU MUST FIRST CONTACT US FOR THE CUSTOMER SERVICE SHIPPING ADDRESS IN YOUR AREA IF YOUR DEALER IS NOT EQUIPPED FOR THIS SERVICE.** Please be sure to pack any items you ship us carefully since we cannot be held responsible for damages incurred during shipping.

This warranty may be transferred to a subsequent owner.

SAVE YOUR ORIGINAL SHIPPING CARTON AND PACKING MATERIALS, AS WELL AS THIS WARRANTY AND YOUR SALES RECEIPT. YOU WILL NEED THEM TO OBTAIN SERVICE UNDER THE PROVISIONS OF THIS LIMITED WARRANTY.



1 Fairchild Court Suite 140
Plainview, NY 11803

Tel. (516) 576 9052, Fax. (516) 576 0826
pinnacle@pinnaclespeakers.com
<http://www.pinnaclespeakers.com>

PR MAN QF REV0809

Free Manuals Download Website

<http://myh66.com>

<http://usermanuals.us>

<http://www.somanuals.com>

<http://www.4manuals.cc>

<http://www.manual-lib.com>

<http://www.404manual.com>

<http://www.luxmanual.com>

<http://aubethermostatmanual.com>

Golf course search by state

<http://golfingnear.com>

Email search by domain

<http://emailbydomain.com>

Auto manuals search

<http://auto.somanuals.com>

TV manuals search

<http://tv.somanuals.com>