

# User Manual

## Philips FM1200 / FM1100 / FM1300

### VHF or UHF Personal Mobile Radio



Dennis Koller PA4DEN  
Jan Buiting PE1CSI

Philips Mobile Radio Collection

July 2001

#### Contents

User Manual .....	1-6
Appendix A, The FM1200 SB0 PMR with Handsfree Kit.....	7
Appendix B, FM1200/1300 Equipment Identification Code System.....	8
Appendix C, Microphone Socket and Power Connector Pinouts.....	9
Appendix D, Local and Remote Mounting Options .....	10
Appendix E, Frequently Asked Questions .....	11

[This document to be printed in colour only]

## Keyboard Layout:

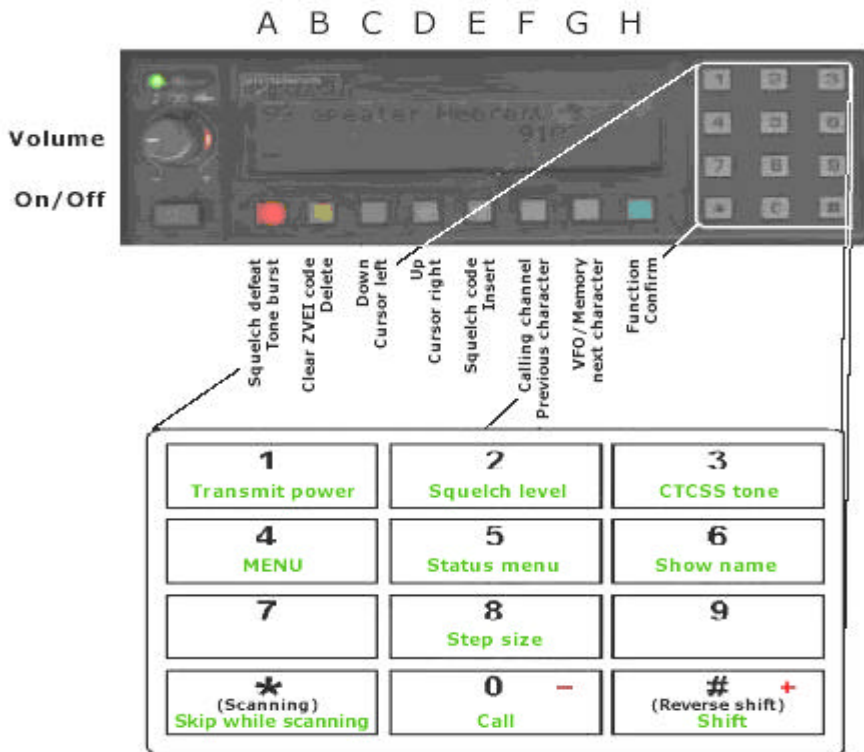

### Main Functions:

Key(s):	Function:
0 1 2 3 4 5 6 7 8 9	Enter channel, frequency or number
*	Scanning
#	Reverse shift
E	Activate tone squelch (CTSS / 5-tone)
F	Go to Calling Channel
G	Switch between VFO and Memory
H	Select second function of next key

### Second (alternate) function:

Key:	Function:
1	Adjust transmit power
2	Adjust squelch trip level
3	Select CTCSS tone
4	To MENU
5	To Status Menu
6	Show names with memory channels
8	Select step size
*	Exclude memory channel from scanning
0	Call
#	Shift + / - / off
E	Select tone squelch
F	Clear Priority Channel
G	Clear memory Channel

When the transceiver is switched on, the upper line of the display shows the current channel or the frequency. If a valid tone code is received, it is displayed in the lower right hand corner of the display. The lower display line shows an S (signal strength) meter in the form of a horizontal bar. This is called the normal state.

To activate the **second function** of a key, press the **H key**. The text 'Select Function' will appear. The second (alternate) function of the next key pressed is activated. Press **H** again to return to the normal state.

## 1. Select Frequency

The transceiver operates in one of three modes. Using the **G** button you may select between **VCO** and **Memory** mode. The third mode is the **Priority Channel** which may be switched on and off with the **F** key.

### VCO mode

In VCO mode any frequency that complies with the selected step size (4) may be entered using the number keys on the keypad. The transceiver automatically rounds off the frequency to a valid entry. For example, if you want to listen at 435.012.500 MHz, at a step size of 12.5 kHz, all you need to do is enter '501':

435.---.--- → 435.0--.--- → 435.012.500

If a step size of 25kHz is used, entering '501' will cause the transceiver to round off to 435.000.000.

### Memory mode

Starting from VCO mode up to 100 preset frequencies per bank may be stored in memory, see Heading 5. These frequencies may be selected when in Memory mode while it is also possible to assign names to channel frequencies. If no frequency has been assigned to the selected channel the transceiver produces an error beep and ignores the number entered.

### Priority Channel mode

Provided a frequency has been assigned to the Priority Channel (see Heading 6), this feature allows you to change to this frequency at the flick of a switch. The Calling Channel may be instantly selected by pressing the **F** key.

## 2. Select CTCSS tone

It may be undesirable for every transmission to be heard on a certain frequency. A system called CTCSS is therefore used to pass only those transmissions containing a sub-audible tone of a specific frequency. In the receiver a CTCSS decoder is used to open the squelch and make the transmission (speech) audible when a valid CTCSS tone is detected.

The frequency of the CTCSS tone may be selected as follows:

*Display:*  
- Press **H** ( Select Function )  
- Press **3** ( TX CT: \*\* )

The lowest frequency is 67.0 Hz, the highest, 250.3 Hz. The quasi-value 'None' is available to disable CTCSS. Separate CTCSS frequencies may be used for TX and RX

## 3. Tone squelch

The squelch may remain closed until a valid ZVEI 5-tone code is received. It is also possible to

transmit a ZVEI 5-tone sequence at the start of every transmission.

### Activate:

The tone squelch is activated by pressing the **E** key. When receiving, the yellow LED lights. When transmitting, the symbol 'T' appears behind the frequency.

### Adjust:

The code may be set as follows:

*Display:*  
- Press **H** ( Select Function )  
- Press **E** ( RX: )

Now set the tone for the squelch. The tone code has to be entered using the number keys. If a number flashes, this indicates a DTMF tone.

- Press **H** ( TX: )

Now set the tone to be transmitted.

### 1750 Hz tone burst

A tone burst is transmitted by pressing the PTT and Squelch Defeat buttons at the same time. The frequency of the tone burst may be adjusted in the Audio menu.

## 4. Select Step Size

*Display:*  
- Press **H** ( Select Function )  
- Press **8** ( Step size: \*\* )

The desired step size is selected by pressing the 0 and # keys (← or →). Confirm your selection by pressing any other key.

## 5. Store favourite channels

Up to 100 favourite channels per bank may be pre-set in the transceiver. A channel is stored as follows:

*Display:*  
- Select VCO mode (43\*.\*\*\*.\*\*\* )  
- Enter the desired frequency and choose SHIFT and/or CTCSS if required  
- Press **H** (Select Function )  
- Press **G** (Store in: xx)  
- Select a number, if number has an arrow in front of it, it has been taken for another frequency. This is replaced.  
(Store in: xx)  
- Press **H**  
- If desired, give the channel a name.  
(Name: )  
See Heading 10 for text entry.  
- Press **H** again

See Heading 7 for the name display on/off function.

## 6. Storing Priority (PR) Channel

It is very useful, particularly in mobiles, to have a single button available to retrieve the Priority Channel. The Priority Channel frequency may be programmed as follows:

- Display:*
- Select VCO mode (43\*\*\*.\*\*\* )
  - Enter the desired frequency and set SHIFT and/or CTCSS if required
  - Press **H**. ( Select Function )
  - Press **F**. ( Calling Frequency? )
  - Press **H**.
  - If desired, give the channel a name ( Name: )
- See Heading 10 for text entry.
- Press **H** again. ( Processing )

See Heading 7 for the name display on/off function.

## 7. Name display on/off

Names may be assigned to memory channels. The displaying of the name may be switched on and off, as follows:

- Display:*
- Press **H** (Select Function )
  - Press **6**

## 8. Clear memory channel

- Display:*
- Select Memory mode (\*\* \*\*\*\*\* )
  - Select the channel to be cleared
  - Press **H** ( Select Function )
  - Press **S** ( Clear Channel? )
  - Press **H** ( Processing )

## 9. Clear Priority (PR) Channel

- Display:*
- Select Priority Channel (button F) (A \*\*\*\*\* )
  - Press **H** (Select Function )
  - Press **F** (Clear Calling?)
  - Press **H** ( Processing )

## 10. Text entry

Text entry using the keys on the keypad is largely similar to the method used on GSM phones. For example, the letters A, B and C are 'behind' the

number key '2'. The desired letter or character is selected by repeatedly pressing a number key.

The **B** button is used to delete a character. Text beyond the cursor position will shift back, just as with the DEL key when using a word processor. The **E** button is used to enter a space. All characters behind the keys on the keypad are shown in the table below. The up and down arrow keys **C** and **D** may be used to step through a character group. The cursor may be moved by pressing the left and right arrow keys **F** and **G**.

On completion of text entry, press the **H** key.

0		"	#	\$	%	&	'	(	)	*	+	,	-	.	/
1	/	:	;	<	=	>	?	@	^	_					
2	A	B	C	a	b	c	[	{							
3	D	E	F	d	e	f	'								
4	G	H	I	g	h	i	!								
5	J	K	L	j	k	l									
6	M	N	O	m	n	o	\		~						
7	P	Q	R	S	p	q	r	s							
8	T	U	V	t	u	v	]	}							
9	W	X	Y	Z	w	x	y	z							

## 11. Scanning

The transceiver is capable of scanning in Memory as well as in VFO mode:

To scan all frequencies:

- Switch to VFO mode by pressing the **G** button
- Press the \* button

To scan memory channels:

- Select MEMory mode by pressing the **G** button
- Press the \* button

Press any key to stop scanning. During scanning the red LED is illuminated.

If the transceiver has halted on a certain channel, scanning may be resumed by pressing \* again.

During scanning indicator **F** is displayed.

## 12. Exclude channels from scanning

It is possible to skip certain memory channels while scanning.

- Display:*
- Select MEMory mode (\*\* 43\*\*\* )
  - Select the relevant channel
  - Press **H** (Select Function )
  - Press \*

Indicator **E** shows that the channel is skipped during scanning.

To cancel this setting, perform the same keypresses in reverse order. The indicator will disappear.

### 13. Transmitter power

Transmitter output power is dependent on:

- The value set by the internal software
- Antenna matching
- Temperature

To set transmitter power:

- Display:*  
(Select Function )
- Press **H**
  - Press **1**

The transmitter power level may be adjusted by pressing keys **0** and **#** or **C** and **D**. Confirm desired level by pressing any other key.

### 14. Repeater shift setting

On the UHF radio, the default value for the repeater shift is 1.6MHz. On VHF, the default value is 600 kHz. The MENU allows any other value to be set up (see Heading 17).

To switch repeater shift on and off:

- Display:*  
(Select Function )
- Press **H**
  - Press **#**

Next there are 3 options:

- Shift off (43\*.\*\*\*.\*\*\* )
- Shift negative (TX frequency 1.6MHz lower)  
(43\*.\*\*\*.\*\*\* -S)
- Shift positive (TX frequency 1.6MHz higher)  
(43\*.\*\*\*.\*\*\* +S)

### 15. Reverse shift

Reverse shift is useful for temporary listening on the repeater input frequency, and transmitting on the repeater output frequency.

Reverse shift may be switched on and off by pressing **#** only, i.e., without first pressing the **H** button. With reverse shift enabled, an 'R' is shown on the display instead of 'S'.

### 16. Squelch (trip) level setting

- Display:*  
(Select Function )
- Press **H**
  - Press **2**

The squelch level is then adjustable using the keys **0** and **#** or **C** and **D**.

## 17. The MENU

For lack of buttons on the FM1200/1100/1300, a number of less frequently used functions have been gathered into a Menu. Once in the menu, you can select between available options by means of the 0 and # keys.

Option values may be modified as required by pressing the **H** button. In that case, the indicator with the **H** key will be visible.

Options requiring a number or text to be set may also be edited using the **H** key. However, these entries need to be confirmed by pressing an unused key or the **H** key.

Access the menu as follows:

- Press **H** (Select Function )
- Press **4** (xxxxxxx MENU)

To keep the menu reasonably tidy, items have been distributed across submenus. The submenus may be viewed from the main menu by pressing the **H** button. Like the main menu, submenus are closed by pressing an unused key.

#### Available menu items:

#### Options:

- **Shift** \*\*\*\*\* kHz  
Define amount of shift for repeaters. Adjust value using number keys.

- **TX with SQ** Possible / Not possible  
With 'Not possible' selected the transmitter can not be keyed while a signal is received.

- **Limit TX time** \*\*\*\* sec  
Define maximum duration of transmission. Adjust value with number keys. 0 = none.

- **Range** 430-440 / 300-500  
144-146 / 100-200  
Select VCO range. (UHF or VHF)

- **Scan mode** Wait for silence / Wait briefly / Scan until busy  
Indicates transceiver activity while in scanning mode.

- **Scan mode** Carrier / Squelch  
With 'Carrier' selected, the transceiver evaluates signal strength, this is faster. 'Squelch' is better for weak signals.

**Audio** Submenu!  
- **Microphone** Normal / PA  
The AF input may be sent to the loudspeaker output.

- **Suppress** Tones >500Hz / 1750Hz only / Never

Suppress beep tones. Indicator C lights while suppressing.

- **Beep** **On / Off**  
Keyboard beep.

- **Beep** **Volume: ---**  
Volume of keyboard beep.

- **Roger beep** **On / Off**  
Transmit a beep on keying off the transmitter.

- **DTMF tones** **\*\*\* ms**  
Define length of DTMF tones. Adjust value with number keys.

- **ZVEI tones** **\*\*\* ms**  
Define length of ZVEI tones used for 5-tone calling. Adjust value with number keys.

**Tone burst** **\*\*\* Hz**  
Define audio frequency used for opening repeaters.

### Callsign generator Submenu!

- **Callsign generator** **On / On (hold TX) / Off**  
The transceiver may transmit text in Morse. 'Hold TX' causes the transmitter to remain keyed until the text is finished.

- **After call** **On / Off**  
Callsign may be transmitted immediately after 5-tone sequence.

- **Callsign** **<text>**  
Define callsign transmitted during normal transmissions. See Heading 10.

- **Callsign generator** **Speed: \*\*\***  
Define Morse speed (0-40).  
Adjust value with number keys.

- **Callsign generator** **Only TX / TX & LSP**  
Callsign may be sent to loudspeaker

- **Callsign generator** **After TX: \*\*\* sec**  
Callsign generator is activated \*\*\* seconds after the transmitter is keyed. Adjust value with number keys.

- **Callsign generator** **Every: \*\*\* sec**  
Callsign generator is activated every \*\*\* seconds.  
Adjust value with number keys.

### User Submenu!

- **LCD backlight** **Off after: \*\*\* s**  
LCD backlight is switched off automatically \*\*\* seconds after last action.

- **My number** **\*\*\***  
Define user's personal 5-tone code. The transceiver produces an alarm tone on reception of this code.

- **Reply** **\*\*\***  
This code may be transmitted when the personal code is received.

- **Reply** **Yes / No**  
Enable/disable replying to personal code.

- **Key acceleration** **Accel.: X**  
Define acceleration of up and down key. The longer the key is pressed, the faster frequencies will be stepped through.

- **Keys** **Repeat / Once**  
If a key is held pressed, its function may be automatically repeated.

- **Settings** **Update / Fixed**  
When 'Update' is selected, all settings are stored on switching off. 'Fixed' allows settings to be stored manually using the next menu item. When switched on, the transceiver employs the previously stored settings.

- **Settings** **Store**  
This allows you to store settings.

- **Memory** **Copy now**  
This allows the contents of the 24C65/64 EEPROM to be copied.

- **<Language>** **Nederlands / English / Deutsch**  
Select one of three languages.

- **Status** **Diagnosis**  
If the error indicator F is visible, the cause of the problem may be called up by pressing the **H** button.

## 18. Calls

The transceiver allows up to 10 different tone sequences to be stored. These tone sequences may be used to selectively call up stations.

**Calling:** *Display:*  
- Press **H** (Select Function )  
- Press **0** (Call: )  
- Select the number/station to be called  
- Press **#**

**Defining the codes:** *Display:*  
- Press **H** (Select Function )  
- Press **0** (Call: )  
- Select the number/station to be called.  
- Press **H** (Name: )  
- Enter name, see Heading 10  
- Press **H** to confirm (Nr. )  
- Enter the number  
- Press **H** to confirm

The **H** button is used to confirm entries. Cancel entry with any other key.

## Appendix A. The FM1200 SB0 PMR with Handsfree Kit

The FM1200 SB0 is an FM1000 family member specially made for large trunked radio networks formerly operated by several large Electricity Boards in the UK. The FM1200 B0 has a Type-1 control board and was designed to cover 132-156 MHz. It usually comes with a remote control kit comprising a handsfree function based on a VOX. In addition to the transceiver proper and the FM1000 microphone you will have a remote mounting cable (5 m), a VOX/Junction Box, a numeric keypad display console with dashboard mounting socket, a VOX (condenser) microphone, a combined VOX on/off/PTT switch and connecting cables. Additional items that are not always supplied include a POCSAG module (a.k.a. 'dongle'), a strain relief clamp for the microphone cable, a loudspeaker and a transceiver mounting bracket.

This sumptuously equipped PMR set is ideal for mobile use because of the VOX (voice operated TX control) function and remote mounting option that allows the transceiver proper to be mounted out of sight.

The VOX/Junction box is usually supplied without the various cables connected. The relevant connector functions are illustrated below.

The VOX is a hardware-only add-on and may be omitted without problems. To convert the radio to local control, remove the front cover blanking panel from the transceiver and instead fit the display console using two M2.5 Pozidriv screws inserted into the outer two round holes. The display is electrically connected to the main transceiver via a white SIL connector at the end of a short internal cable. The microphone is plugged into the socket formerly used for the remote connection cable, and the loudspeaker is connected via two pins on the power connector at the rear.

The FM1200 will usually cover frequencies between 125 and about 162 MHz, which is well beyond the factory specification. VCO re-adjustment to obtain larger frequency coverage is not recommended.

You may find one or two small plug-on daughterboards inside the FM1200 B0. These have no function for the conversion and need to be removed. The two lengths of 'zebrastrip' flexible ribbon cable that are no longer used may be tucked away inside the hollow space in the plastic part on front of the transceiver.

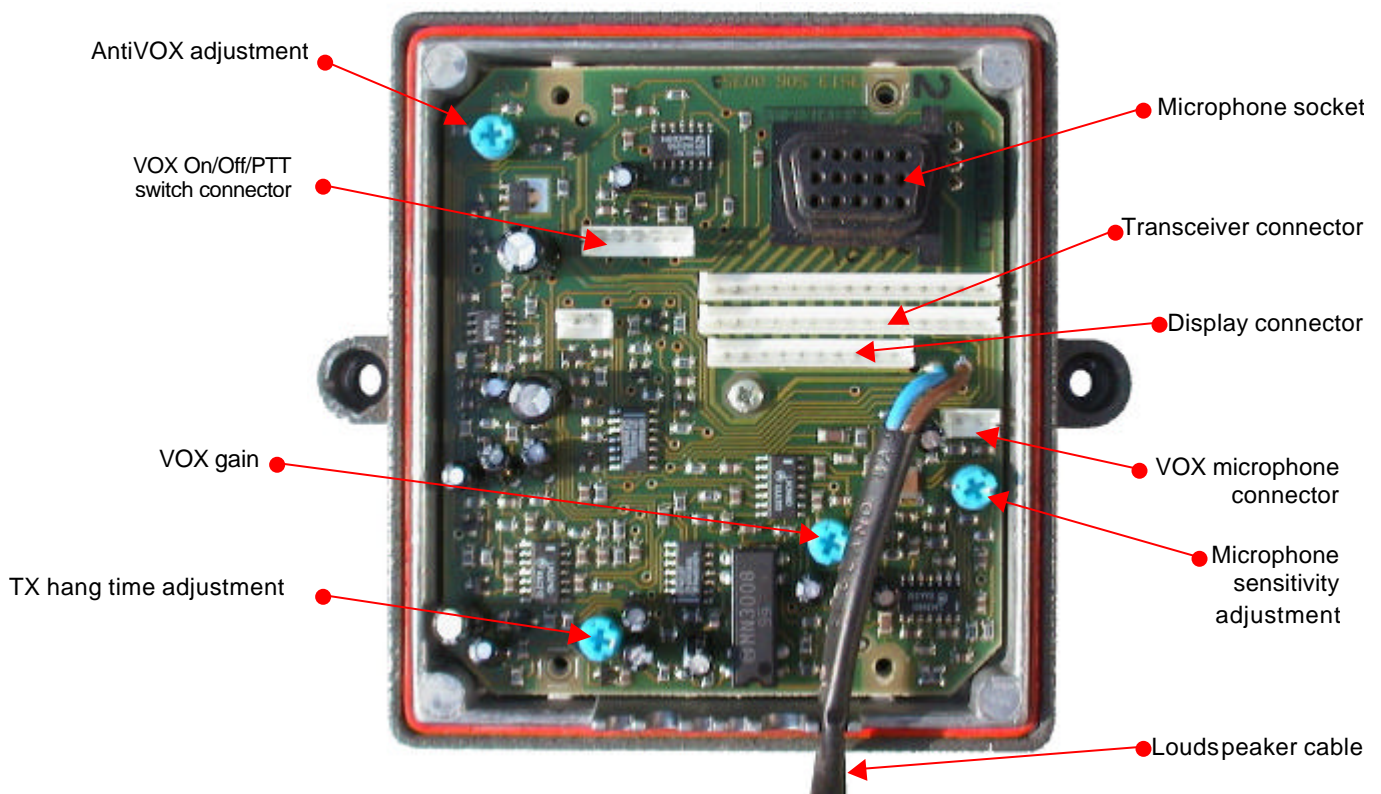

The VOX/Junction Box normally comes factory-adjusted for typical in-vehicle use so it will not be necessary to tweak the microphone sensitivity and transmitter hang time presets on the board. To avoid the VOX being erroneously triggered by received signals, fit the small condenser microphone as far away as possible from the loudspeaker. The AntiVOX circuit will attempt to cancel loudspeaker sounds.

All cables in the VOX kit should be inspected for wear and tear on the outside sleeving as well as damage incurred when these kits were removed from vehicles.

## Appendix B. FM1200/1300 Equipment Identification Coding System

### EQUIPMENT VARIATIONS

The sub-assemblies fitted to the transceiver will vary according to the role in which it is used. The complement of sub-assemblies for any particular equipment is indicated by an Order Code number marked on the back case of the equipment. A typical Order Code number is given below, together with a list of those codes which are not self-explanatory.

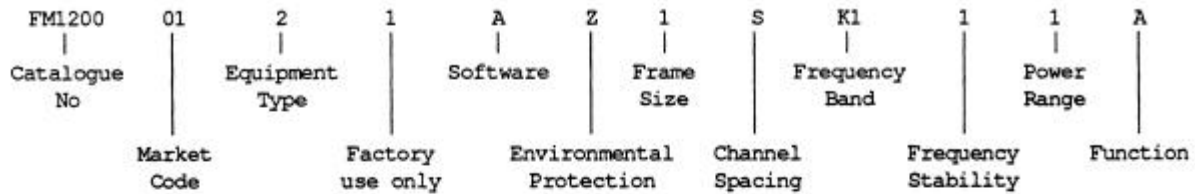

#### Market Code

01	Standard production
02	France
03	Germany
04	USA
09	Canada
12	Finland
19	Malaysia
30	Hong Kong

#### Frequency Band

E0	68 - 88MHz
B0	132 - 156MHz
A9	146 - 174MHz
K1	174 - 208MHz
K2	192 - 225MHz
K9	220 - 230MHz
	225 - 235MHz

#### Equipment Type

2	FFSK Transceiver Type FM1200
3	FFSK Transceiver Type FM1300

TM	400 - 440MHz
T4	425 - 450MHz
U0	440 - 470MHz
W1	470 - 500MHz
W4	500 - 520MHz

#### Software

0	Less EEPROM and EPROM
A	FM1200, Standard Console
B	FM1200, Keypad Console
C	FM1300, Standard Console
D	FM1300, Keypad Console

#### Frequency Stability

1	±5ppm
2	±2ppm

#### Environmental Protection

Z	Standard Production
1	IP54

#### Power Range

1	Standard VHF (1-25/30W)
2	Standard UHF (6-25W)
3	Low Power UHF (1- 6W)
4	POCSAG Paging Facility

#### Frame Size

1	Standard Frame
2	Extended Frame (required for Keypad Console and/or External MODEM)

#### Function

0	Less Control/Digital-Signalling PCB
A	FM1200 (FM)
B	FM1200 with Modem Interface (FM)
C	FM1300 (FM)
D	FM1300 with Modem Interface (FM)
E	FM1200 (PM)
F	FM1200 with Modem Interface (PM)
G	FM1300 (PM)
H	FM1300 with Modem Interface (PM)
I	FM1300 (FM)
J	FM1300 with Modem Interface (FM)
K	FM1300 (PM)
L	FM1300 with Modem Interface (PM)

#### Channel Spacing

S	12,5kHz
R	20kHz
V	25kHz



# Appendix C. Microphone Socket and Power Connector Pinouts

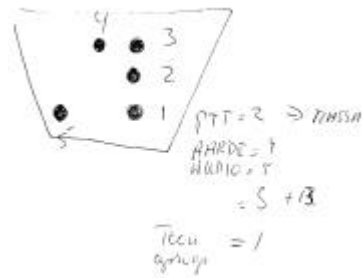
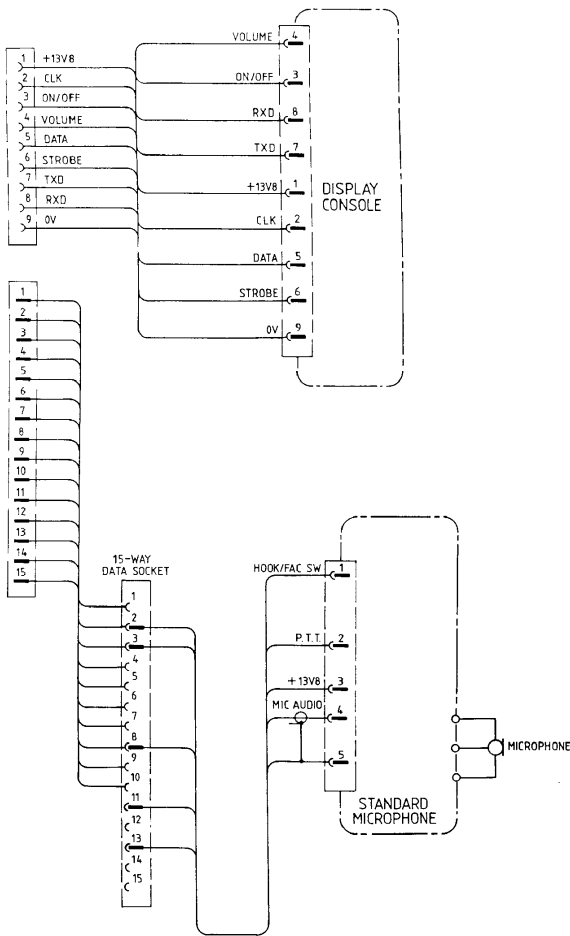

1. LOUDSPEAKER (LIVE)	5. REMOTE ALARM
2. BATTERY (+)	6. EXTERNAL ALERT
3. LOUDSPEAKER (GROUND)	7. BATTERY (-)
4. 0V	8. IGNITION

NOTE. OBSERVE LOUDSPEAKER POLARITY WHEN CONNECTING TEST EQUIPMENT (eg AF POWER METER) TO THE RADIO

CONNECTOR  
REAR VIEW

E 3880

## Appendix D. Local and Remote Mounting Options

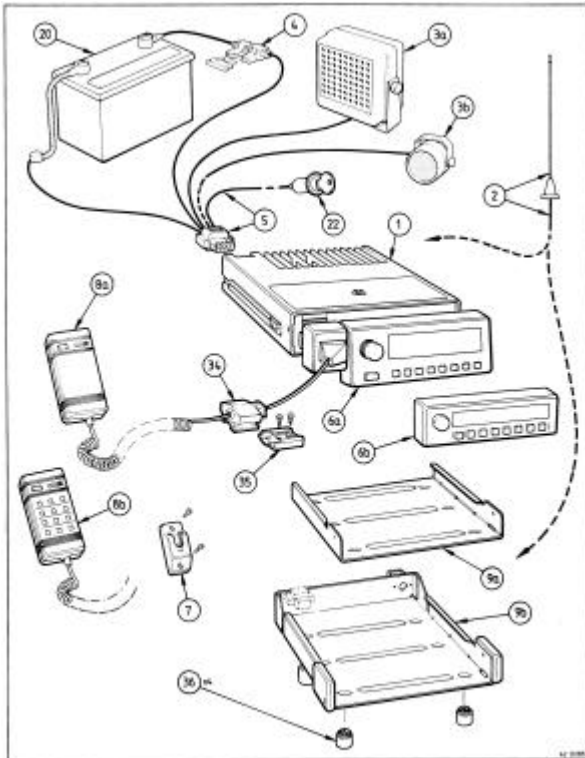

Basic Installation Diagram for Local Control

- (1) Radio
- (2) Antenna and Feeder Cable
- (3a) Loudspeaker, standard
- (3b) Loudspeaker, small
- (4) Fuseholder
- (5) Battery Lead Assembly
- (6a) Standard (4-6 digit) Console
- (6b) Basic Console
- (7) Rest (Mic Installation Kit)
- (8a) Microphone, standard
- (8b) Microphone, DTMF
- (9a) Cradle, standard mount
- (9b) Cradle, Cassette mount
- (10) Junction Box
- (11) Control Cable, 1, 5 or 50m
- (12) Mate n' Lock Housing
- (13) Bracket, Console
- (14) Cradle, Console
- (15) Fascia (for Remote Control)
- (16) Console Plate
- (17) 9-way Connector
- (18) Magnet
- (19) Key (Cradle release)
- (20) Vehicle Battery
- (21) Console Cable (9-way)
- (22) Vehicle Ignition Switch
- (23) Volume Control Knob
- (24) Front Panel, Console
- (25) Rear Panel & PWB, Console
- (26) Graphics Panel
- (27) Bezel
- (28) Scotchlok Connector
- (34) Strain Relief Clamp
- (35) Clamp Support
- (36) Spacer, Cradle (4 off)

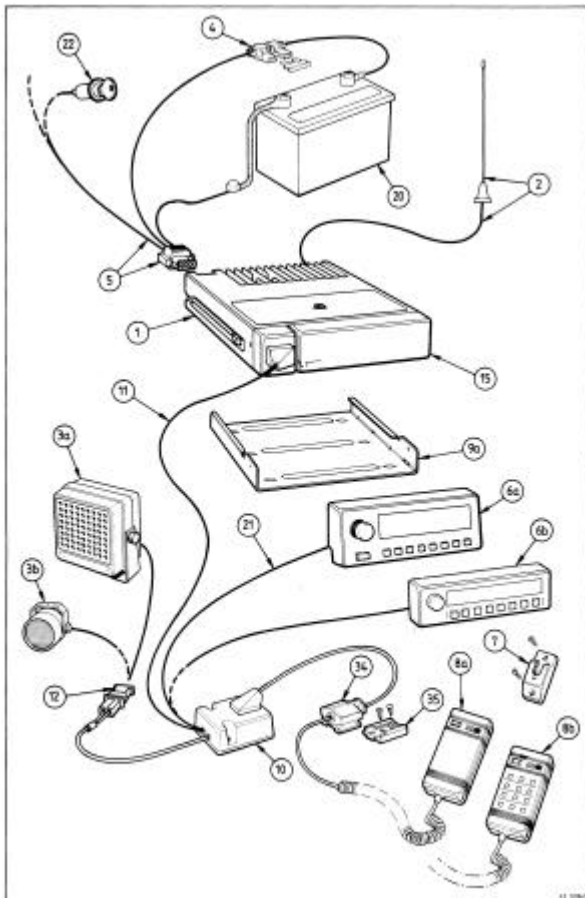

Basic Installation Diagram for Remote Control

Note: numeric keypad and VOX/Junction box not shown in these drawings.

## Appendix E. Frequently Asked Questions (FAQ)

Below is a list of questions we have been asked over and over again, together with the standard answers supplied.

### **1. My converted FM1200 does not generate tones, how come?**

Step through the Status Menu (**H-5**). If you see: 'Tone CPU not active', you have either made an error in mounting the tone system PROM (32-pin PLCC 27C256R), or the wire link next to the tone CPU is not set to the 'ground' position. Check your solder work carefully using a continuity tester.

### **2. Is it possible to omit the tone PROM, it seems such a hassle to mount!**

Sure, but you will be unable to use any of the functions that require tone processing (DTMF, CTCSS, 5-tone calling, 1750 Hz, etc.).

### **3. Can I use the FM1200 70cms for 9k6 packet radio?**

We are not packet radio users but we're told that 9k6 is not possible because the varicap-based automatic RF tracking system inside the FM1200 will faithfully counteract any frequency change beyond normal deviation caused by modulation signals. 1k2 packet radio is possible without problems using a modem hooked up to the microphone connector.

### **4. Other stations tell me my deviation is too low, how can I adjust it?**

They are probably listening in 25 kHz bandwidth. If yours is an 'S' FM1200, (examine the type number) then you can rely on it that the peak deviation has been accurately set to  $\pm 2.5$  kHz by the factory, as required for 12.5 kHz channel spacing. Similarly the 'R' radio will produce  $\pm 4.0$  kHz peak deviation, and may in rare cases require some reduction if used on 12.5 kHz spaced nets. Open up the microphone and check electret microphone front is clean and element is properly seated in its holder.

### **5. Does your conversion defeat the Philips PDP and CDP programming tools?**

Yes. Having converted the radio it will no longer recognize the PDP or CDP.

### **6. Is your firmware and displayware suitable for 4-metre (E0-band) FM1000's?**

No, it is not. The E0 band version of the FM1100/1200 radio is extremely rare in the Netherlands. An update may be developed in the future.

### **7. Is your firmware and displayware suitable for FM1000's with a 'basic' or 'standard' console?**

No, it is not. The text and graphics used by the conversion exceeds the capacity of the 'standard' head, which only allows a number of fixed symbols to be used and does not have a numeric keypad. The 'basic' console does not even have a display so its use is out of the question. We suggest upgrading the radio by getting your hands on a numeric keypad head.

### **8. Where can I obtain the complete documentation of these wonderful radios?**

A documentation package is available, consisting of (1) FM1100 Service manual, (2) Numeric Keypad Manual and (3) FM1200/1300 Service Supplement. The lot weights approx 1 kg. Price Euro 20 incl. P&P. Please contact Jan, PE1CSI on email [pe1csi@amsat.org](mailto:pe1csi@amsat.org).

### **9. On my radio, the display test does not work to start with. I'm getting solid black blocks only.**

This problem may be caused by a faulty or incorrectly fitted display EPROM, or LK4 (A15 jumper) in the display console being set to the wrong position. If the display EPROM is an 27C128 or 27C256, the centre pad of LK4 should be connected to +5V (left-hand position). If a 27C512 is used, LK4 should be connected to A15 (default position, right-hand).

### **10. I have just acquired an FM1000 radio at a local rally. Can I use it with your conversion?**

This is the most annoying question we get. There is no such thing as an 'FM1000'. The designation FM1000 refers to a family of more than 50 different transceivers rather than an individual type. First do your homework by analysing the type code printed on the label at the rear of the radio. Use Appendix B for reference.

### **11. I have available a boxful of FM1000 parts and other Philips PMR bits, what should I do with it?**

Contact Jan Buiting, PE1CSI, proprietor of the Philips Mobile Radio Collection, on email [pe1csi@amsat.org](mailto:pe1csi@amsat.org). Jan will give you a Freepost address so you can turn your surplus into a donation to the Collection and pay no postage.

### **12. Is your firmware and displayware suitable for VHF or UHF FM1100's?**

Not completely. Watch for postings in the [FM1000] Newsgroup, or [uk.amateur.radio].

## Free Manuals Download Website

<http://myh66.com>

<http://usermanuals.us>

<http://www.somanuals.com>

<http://www.4manuals.cc>

<http://www.manual-lib.com>

<http://www.404manual.com>

<http://www.luxmanual.com>

<http://aubethermostatmanual.com>

Golf course search by state

<http://golfingnear.com>

Email search by domain

<http://emailbydomain.com>

Auto manuals search

<http://auto.somanuals.com>

TV manuals search

<http://tv.somanuals.com>