



## Model SEH50 High Efficiency Electric Fryer



(Model shown is SEH50/SEH50T with optional Intellifry Computers, casters and filtration system)

### STANDARD ACCESSORIES

- Solid State Control
- Baskets (Twin Size)
- Lift off basket hangers
- 9" adjustable legs
- Stainless steel tank, front, door and sides.
- Drain Valve Interlock
- Tank racks
- Clean out rod
- Fryer cleaning brush

### AVAILABLE OPTIONS & ACCESSORIES

- Digital controller
- Intellifry computer
- Solid state back-up control\*
- Filter drawer system (for 2 or more fryers)
- Filter system heat tape (for use with solid shortening)
- 9" adjustable casters
- Basket lifts\*\*
- Stainless steel back
- Stainless steel tank covers
- Bread and Batter cabinet
- Flush hose
- Filter powder
- Filter paper

\* Solid state control equipped with melt cycle and boil-out, and can be used as back-up in combination with the Intellifry or Digital controls.

\*\* Basket lifts to be used in combination with Intellifry or Digital control.

Project \_\_\_\_\_

Item No. \_\_\_\_\_

Quantity \_\_\_\_\_

### STANDARD SPECIFICATIONS

#### CONSTRUCTION

- High production/fast recovery fryer system in any combination of full vat and twin vat fryers with "filter drawer" filtration system. Combinations without filtration, or single fryers also available.
- Welded tank with an extra smooth peened finish ensures easy cleaning.
- Immersion type, sealed construction heating elements with high temperature alloy stainless steel sheath.
- Solstice Electric fryers are designed with a fixed heating element to eliminate oil migration through pivot components. This design creates a safer working environment by keeping the hot elements in the tank where they belong.
- When used with a filtration system, fryers are available in combinations of two or more units.
- Stainless steel front, door, side panels, and splashback.
- Heavy duty 3/16" (.48 cm) door hinge.

#### CONTROLS

- Solid State controller maintains the fryer temperature between 250°F (122°C) and 380°F (193°C). Solid State controller has built-in melt cycle and boil-out capability.
- Temperature limit switch safely shuts off the fryer if the oil temperature exceeds the upper limit.
- Drain valve interlock switch shuts disables the fryer if the drain is opened preventing accidental fires. The hermetically sealed proximity switch has no moving parts to get contaminated with grease.

#### OPTIONAL FILTER SYSTEM

(Available on 2 or more units)

- Filter drawer glides on self aligning roller-less guides
- 1-1/4" NPT drain valve for quick draining on both full and twin tanks.
- Easy to remove filter unit for fast cleaning and paper replacement.
- Filter piping integrated into the fryer for no-hassle filtering.
- Extra large 3" drain manifold to prevent clogging.

#### APPROVALS

- UL Certified
- CUL Certified
- NSF Listed
- ENERGY STAR Qualified



Pitco Frialator, Inc., P.O. Box 501, Concord, NH 03302-0501 • 509 Route 3A, Bow, NH 03304, USA

(603) 225-6684 • FAX (603) 225-8472 • www.pitco.com

L10-160 Rev 0 (05/03)



# Model SEH50 High Efficiency Electric Fryer

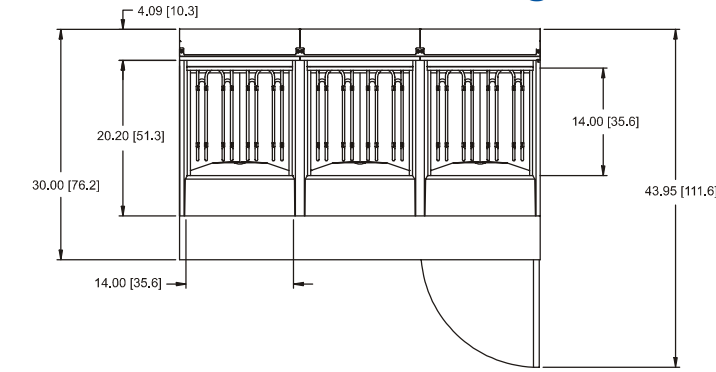

NOTES:

- 440V AND 480V UNITS REQUIRE SEPARATE SINGLE PHASE (115V - 240V) POWER SUPPLY FOR PUMP AND BASKET LIFT OPERATION

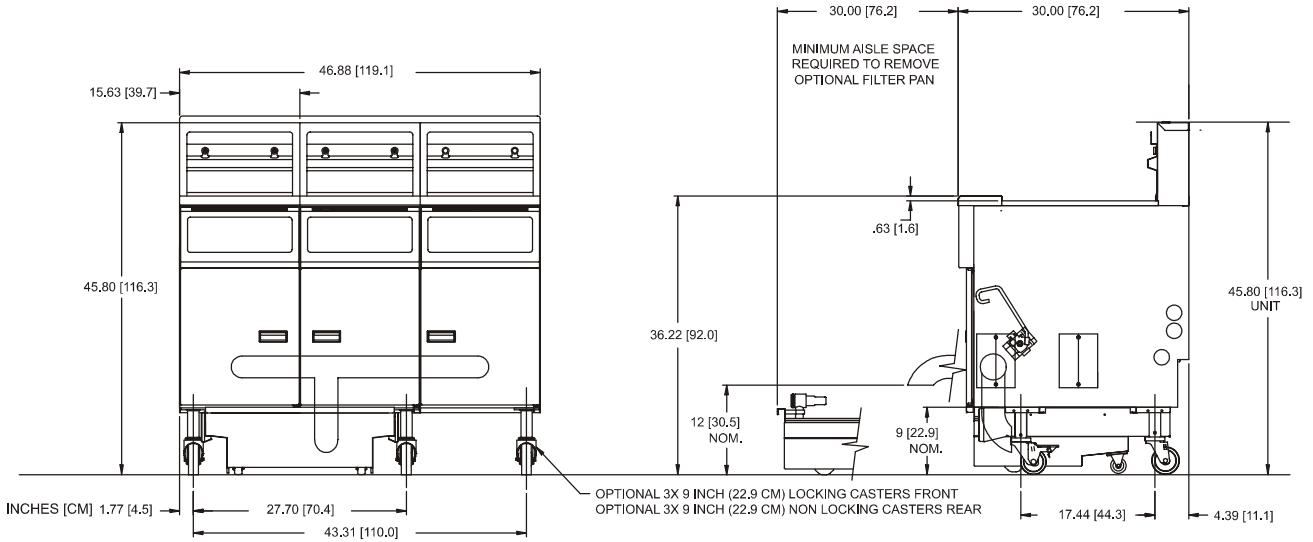

ELECTRICAL				OIL CAPACITY	
Volts/Freq./Phase	AMPS/PH	Volts/Freq./Phase	AMPS/PH	25 pounds (11.3KG) / 3.2 gallons (11liters) per Twin Tank	
208 / 60 / 3	38.9	<b>Fryer Controls:</b>		50 pounds (22.7KG) / 6.1 gallons (23 liters) per Full Tank	
220 / 60 / 3	36.7	120 / 60 / 1PH	0.7	<b>SHIPPING INFORMATION</b>	
240 / 60 / 3	33.7	240 / 50 / 1PH	0.4		
380Y / 220 / 50 / 3	21.3	<b>Filter:</b>		Based on system configuration. Please consult factory.	
400Y / 230 / 50 / 3	20.2	120 / 60 / 1PH	Motor* Heat Tape		
415Y / 240 / 50 / 3	19.5	240 / 50 / 1PH	3.8 0.2		
PERFORMANCE CHARACTERISTICS				ELECTRICAL INPUT	
Twin Tank Frying Area 7" x 14" (17.8 cm x 35.6 cm)				7.0 KW per Twin Tank	
Full Tank Frying Area 14" x 14" (35.6 cm x 35.6 cm)				14.0 KW per Full Tank	
LIMITED WARRANTY					
All Pitco Frialators will be warranted from the date of manufacture against defects in manufacturing or materials as follows:					
<b>Tank</b>		<b>Computers</b>		<b>Other</b>	
10 years parts		2 years parts		1 year parts	
1 year labor		1 year labor		1 year labor	
RETURN POLICY					
No return shipments accepted without prior written approval.					
CANCELLATION FEE					
Orders cancelled or changed after construction has begun, are subject to a 25% charge.					

\* All Motors Are Single Phase.



Pitco Frialator, Inc.,

P.O. Box 501, Concord, NH 03302-0501 • 509 Route 3A, Bow, NH 03304, USA  
(603) 225-6684 • FAX (603) 225-8472 • www.pitco.com

L10-160 Rev 0 (05/03)

Specifications subject to change without notice

Printed in U.S.A

## Free Manuals Download Website

<http://myh66.com>

<http://usermanuals.us>

<http://www.somanuals.com>

<http://www.4manuals.cc>

<http://www.manual-lib.com>

<http://www.404manual.com>

<http://www.luxmanual.com>

<http://aubethermostatmanual.com>

Golf course search by state

<http://golfingnear.com>

Email search by domain

<http://emailbydomain.com>

Auto manuals search

<http://auto.somanuals.com>

TV manuals search

<http://tv.somanuals.com>