

Phoenix 200 Quadricycle

**Owner's Manual
for Maintenance and Safety**

Read this manual carefully. It contains important safety information.

This is an adult vehicle only.

Operation is prohibited for those under 16 years of age.

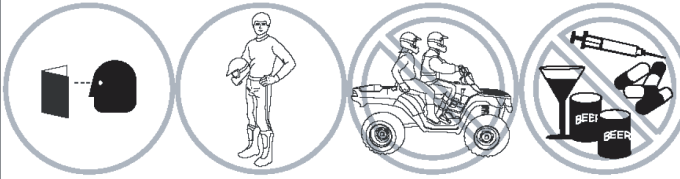
**GB**

Before you operate this vehicle, read the owner's manual.

D

Lesen Sie die Bedienungsanleitung bevor Sie dieses Fahrzeug fahren.

E

Antes de conducir este vehiculo, lea el Manual del Propietario.

F

Lire le manuel du propriétaire avant d'utiliser ce véhicule.

I

Prima di usare il veicolo, leggete il manuale di istruzioni.

FI

Lue aina käyttöohjekirja ennen tämän ajoneuvon käyttöä.

P

Antes de utilizar este veículo, leia o manual do proprietário.

S

Innan du kör detta fordon, läs handboken.

© 2004

7173025



POLARIS
The Way Out.

For your nearest Polaris dealer,
visit www.polarisindustries.com

Polaris Sales Inc.,
2100 Hwy. 55, Medina, MN 55340
U.S.A.

Part No. 9922082 Rev 01
Printed in USA

WELCOME

Thank you for purchasing a Polaris vehicle, and welcome to our world-wide family of Polaris owners. We proudly produce an exciting line of utility and recreational products.

- Snowmobiles
- All-terrain vehicles (ATVs)
- *RANGER* utility vehicles
- Victory motorcycles

Always follow the instructions and recommendations in this manual. The manual contains instructions for minor maintenance, but information about major repairs is outlined in the Polaris Service Manual and should be performed only by a Factory Certified Master Service Dealer (MSD) Technician. Please see your dealer for all of your service needs during (and after) the warranty period.

For more information about Polaris, visit us online at www.polarisindustries.com.



POLARIS[®]
The Way Out.

POLARIS and POLARIS THE WAY OUT are registered trademarks of Polaris Industries Inc.

Copyright 2008 Polaris Sales Inc. All information contained within this publication is based on the latest product information at the time of publication. Due to constant improvements in the design and quality of production components, some minor discrepancies may result between the actual vehicle and the information presented in this publication. Depictions and/or procedures in this publication are intended for reference use only. No liability can be accepted for omissions or inaccuracies. Any reprinting or reuse of the depictions and/or procedures contained within, whether whole or in part, is expressly prohibited.

Printed in USA

2009 Phoenix 200 Quadricycle Owner's Manual

P/N 9922082

TABLE OF CONTENTS

Introduction	4
Safety	7
Features and Controls	22
Operation	29
Emission Control Systems	47
Maintenance	48
Polaris Products	82
Troubleshooting	83
Specifications	86
Warranty	88
Maintenance Log	90
Index	92

INTRODUCTION

The following signal words and symbols appear throughout this manual and on your vehicle. Your safety is involved when these words and symbols are used. Become familiar with their meanings before reading the manual.



The safety alert symbol indicates a potential personal injury hazard.

WARNING

A **WARNING** indicates a hazardous situation which, if not avoided, may result in death or serious injury.

CAUTION

A **CAUTION** indicates a hazardous situation which, if not avoided, may result in minor or moderate injury.

NOTICE

A **NOTICE** indicates a situation that may result in property damage.



The Prohibition Safety Sign indicates an action **NOT** to take in order to avoid a hazard.



The Mandatory Action Sign indicates an action that **NEEDS** to be taken to avoid a hazard.

INTRODUCTION

⚠ WARNING

Failure to heed the warnings and safety precautions contained in this manual can result in severe injury or death. This vehicle is not a toy and can be hazardous to operate. A collision or rollover can occur quickly, even during routine maneuvers, if you fail to take proper precautions.

- Read this owner's manual. Understand all safety warnings, precautions and operating procedures before operating the vehicle.
- Never operate this vehicle without proper instruction. Take a training course.
- This vehicle is an ADULT VEHICLE ONLY. Operation is prohibited for anyone under 16 years of age.
- This vehicle is approved for OFF-ROAD TOWING ONLY. Operating a Quadricycle/trailer combination on public roads is prohibited.

INTRODUCTION

Vehicle Identification Numbers

Record your vehicle's identification numbers and key number in the spaces provided. Remove the spare key and store it in a safe place. The ignition switch must be replaced if all keys are lost.

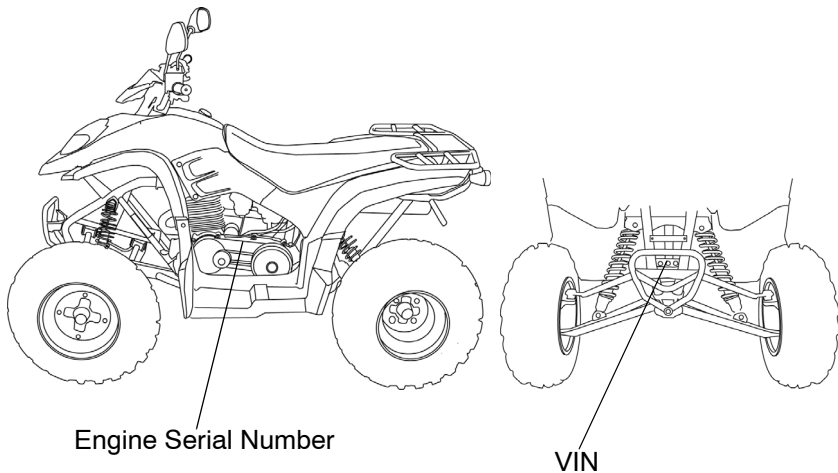

Vehicle Model Number: _____

Frame VIN: _____

Engine Serial Number: _____

Safety Training

When you purchased your new Polaris vehicle, your dealer offered a hands-on safety training course. You were also provided with printed materials that explain safe operating procedures. Review this information on a regular basis.

If you purchased your vehicle from a party other than a Polaris dealer, please request free safety training from any authorized Polaris dealer.

Equipment Modifications

The warranty on your Polaris vehicle may be terminated if any equipment has been added, or if any modifications have been made, that increase speed or power.

The addition of certain accessories, including (but not limited to) mowers, blades, tires, sprayers and large racks may change vehicle handling. Use only Polaris-approved accessories. Know their function and effect on the vehicle.

SAFETY

Safe Riding Gear

Always wear protective clothing to reduce the chance of injury.

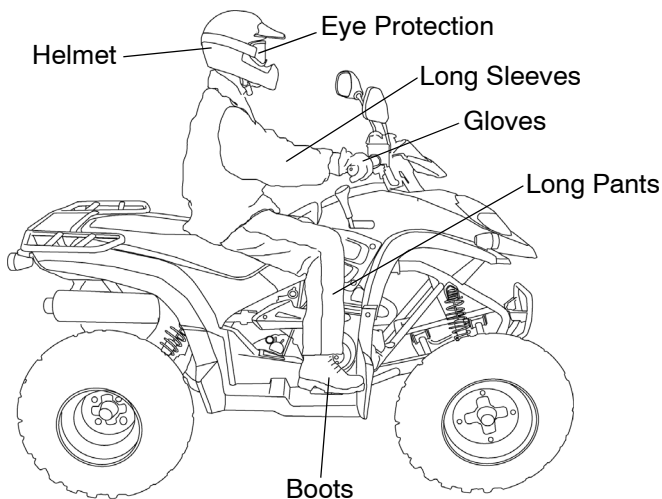

Helmet

Always wear a helmet that meets or exceeds established safety standards.

Approved helmets in the USA and Canada bear a U.S. Department of Transportation (DOT) label.

Approved helmets in Europe, Asia and Oceania bear the ECE 22.05 label. The ECE mark consists of a circle surrounding the letter E, followed by the distinguishing number of the country which has granted approval. The approval number and serial number will also be displayed on the label.

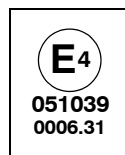

Safe Riding Gear

Eye Protection

Do not depend on eyeglasses or sunglasses for eye protection. When ever riding a Polaris vehicle, always wear shatterproof goggles or use a shatterproof helmet face shield. Polaris recommends wearing approved Personal Protective Equipment (PPE) bearing markings such as VESC 8, V-8, Z87.1, or CE. Make sure protective eye wear is kept clean.

Gloves

Off-road style gloves with knuckle pads are the best for comfort and protection.

Boots

The best footwear is a pair of sturdy over-the-calf boots with low heels.

Clothing

Always wear long sleeves and long pants to protect arms and legs. Riding pants with kneepads and a jersey with shoulder pads provide the best protection.

SAFETY

Operator Safety

⚠ WARNING

Failure to operate the ATV properly can result in a collision, loss of control, accident or overturn, which may result in serious injury or death. Heed all safety warnings outlined in this section of the owner's manual. See the OPERATION section of the owner's manual for proper operating procedures.



Read and understand all warnings, cautions and operating procedures in this manual and on the safety labels before operating this vehicle.

Never operate this vehicle without proper instruction. *Take a training course.* Beginners should receive training from a certified instructor. Contact an authorized Polaris dealer or visit the Polaris web site at www.polarisindustries.com.

Never permit others to operate this vehicle unless they have read and understand this manual and all product labels, and have completed a certified safety training course.

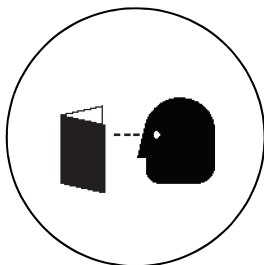

Never allow anyone under 16 years of age to operate this vehicle.



Operator Safety



Handling Gasoline

Gasoline is highly flammable and explosive under certain conditions.

- Always exercise extreme caution whenever handling gasoline.
 - Always refuel with the engine stopped, and outdoors or in a well ventilated area.
 - Do not smoke or allow open flames or sparks in or near the area where refueling is performed or where gasoline is stored.
 - Do not overfill the tank. Do not fill the tank neck.
 - If gasoline spills on your skin or clothing, immediately wash it off with soap and water and change clothing.
 - Turn the fuel valve off whenever the vehicle is stored or parked.
-



Never start the engine or let it run in an enclosed area. Operate this vehicle only outdoors or in well-ventilated areas.



Always inspect your vehicle before each use to verify that it's in safe operating condition. Follow the inspection and maintenance procedures outlined in this manual. See page 31.

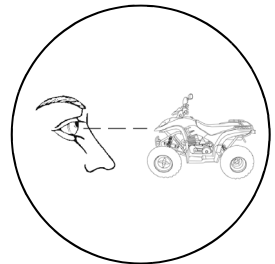

Always wear an approved helmet that fits properly. Wear eye protection (goggles or face shield), gloves, boots, long sleeves and long pants.



SAFETY

Operator Safety



Never consume alcohol or drugs before or while operating this vehicle.



Keep both hands on the handlebars. Keep both feet on the footrests.



Never carry a passenger. The purpose of the long seat is to allow the operator to shift position as needed during operation. It is not intended for carrying passengers.

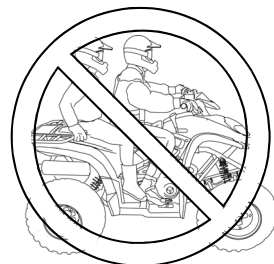

Operator Safety



Never carry a passenger on the rear rack. Ejection from the vehicle or contact with moving components can result in serious injury or death.



Operating on paved surfaces may seriously affect the handling and control of the Quadricycle and could result in loss of control, accident and/or injury. Avoid sudden turns or swift movement of the handlebars.



Never operate at excessive speeds. Travel and turn at speeds appropriate for the terrain, visibility, operating conditions and your experience.

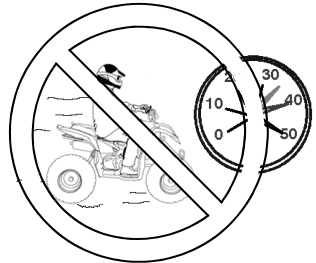

SAFETY

Operator Safety



Always follow the procedures outlined in this manual for turning. Never turn sharply at excessive speeds, which can lead to vehicle overturn. See page 35.



Never attempt jumps or other stunts.



Always follow the procedures outlined in this manual for driving through water. Never drive through deep or fast-flowing water. See page 41.



Operator Safety



Always follow the procedures outlined in this manual for driving on hills. See page 37. Never operate on hills too steep for this vehicle or for your abilities. Practice on smaller hills before attempting larger hills. Avoid climbing hills steeper than 25°.

Always follow the procedures outlined in this manual for driving downhill and for braking on hills. See page 39.



Always follow the procedures outlined in this manual for braking if you stall or roll backwards while climbing a hill. Never back down a hill. See page 40.



Always follow the procedures outlined in this manual for crossing the side of a hill. See page 38. Never attempt to turn this vehicle around on any hill until you've mastered (on level ground) the turning technique outlined in this manual.



SAFETY

Operator Safety

Always use the size and type of tires specified for your vehicle. Maintain the proper tire pressure.



Always travel slowly when operating on unfamiliar terrain. Use extra caution.



Always follow the procedures outlined in this manual for driving in reverse. See page 43.



Use caution when operating on rough, slippery or loose terrain.



Always follow the procedures outlined in this manual for operating over obstacles. See page 42.



Always follow the procedures outlined in this manual for operating on slippery or loose surfaces. Use extra caution. Always avoid skidding or sliding. See page 36.



Operator Safety



Never operate this vehicle on a frozen body of water.



Never modify a Quadricycle through improper installation or use of accessories.



Never exceed the stated load capacity for your vehicle. Cargo must be properly distributed and securely attached. Reduce speed and follow the instructions in this manual for carrying cargo or towing. Allow a greater distance for braking.



If this vehicle has been involved in an accident, always have an authorized Polaris dealer inspect the entire vehicle for possible damage, including (but not limited to) brake, throttle and steering systems.



Hot components can cause serious burns and fire. Do not touch hot exhaust system components. Always keep combustible materials away from the exhaust system.



Always remove the ignition key when the vehicle is not in use to prevent unauthorized use or accidental starting.

For more information about Quadricycle safety, contact an authorized Polaris Quadricycle dealer or visit the Polaris web site at www.polarisindustries.com.

SAFETY

Safety Labels and Locations



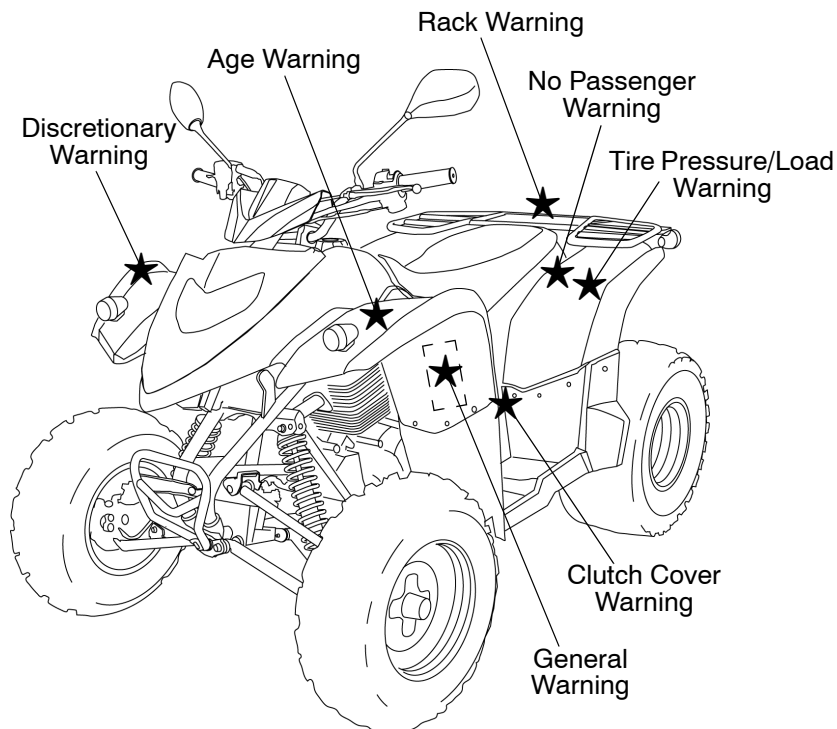

Warning labels have been placed on the vehicle for your protection. Read and follow the instructions on each label carefully. If any of the labels shown in this manual differ from the labels on your vehicle, always read and follow the instructions of the labels on the vehicle.

If an informational or graphic label becomes illegible or comes off, contact your Polaris dealer to purchase a replacement. Replacement *safety* labels are provided by Polaris at no charge. The part number is printed on the label.

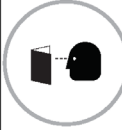

Safety Labels and Locations



GB Before you operate this vehicle, read the owner's manual.

D Lesen Sie die Bedienungsanleitung bevor Sie dieses Fahrzeug fahren.

E Antes de conducir este vehículo, lea el Manual del Propietario.

F Lire le manuel du propriétaire avant d'utiliser ce véhicule.

I Prima di usare il veicolo, leggete il manuale di istruzioni.

FI Lue aina käyttöohjekirja ennen tämän ajoneuvon käyttöä.

P Antes de utilizar este vehículo, lea o manual do proprietário.

S Innan du kör detta fordon, läs handboken.

© 2004
7173025

General Warning

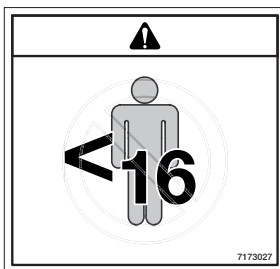

Age Warning



Clutch Cover Warning

SAFETY

Safety Labels and Locations

Discretionary Warning

WARNING

Never operate this ATV on HILLS steeper than 25 degrees $\leq 25^\circ$. To prevent overturn on hilly terrain, use throttle and brakes gradually, and shift weight uphill.

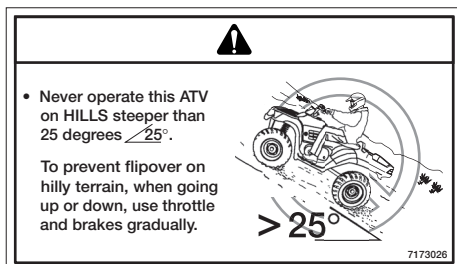

Rack Warning

DO NOT TOW FROM RACK OR BUMPER. Vehicle damage or tipover may result causing severe injury or death. Tow only from tow hooks or hitch. Max. Rack 70 lbs. (31.7 kg)

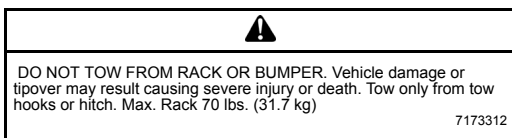

Hitch Warning

Exceeding vehicle towing limit could lead to an accident. Reduce speed when towing a trailer. Read owner's manual for details. Trailer Tongue Weight should be about 10% of the Gross Trailer Weight, and should not exceed 13.6 kg (30 lbs).

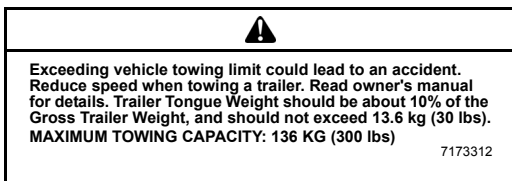

MAXIMUM TOWING CAPACITY: 136 KG (300 lbs)

Safety Labels and Locations

“No Passenger” Warning

WARNING

NEVER ride as a passenger.
Passengers can cause a loss of control, resulting in SEVERE INJURY or DEATH.



Tire Pressure/Load Warning

Improper tire pressure or overloading can cause loss of control.

Loss of control can result in severe injury or death.

- Cold tire pressure:
 - Front: 4.0 psi (27.6 kPa)
 - Rear: 4.0 psi (27.6 kPa)
- Maximum weight capacity: 285 lbs. (129 kg)

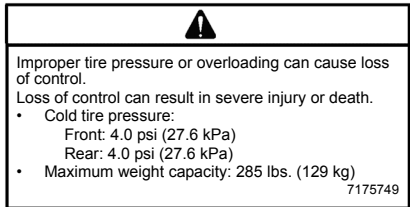

FEATURES AND CONTROLS

Switches and Levers

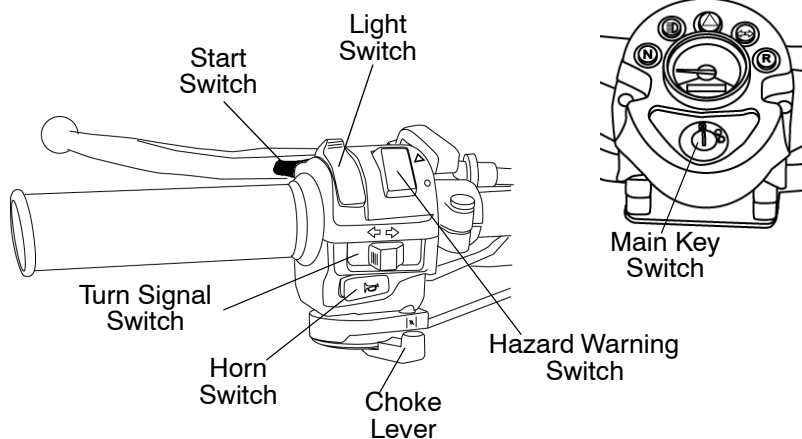

Main Key Switch

- ☒ Turn the main switch to the OFF position to stop the engine and end all electrical power to the vehicle.
- ⦿ The main key switch must be in the ON position before starting the engine. The headlights are not on in this position.
- ⚙ Move the key switch to the LIGHTS ON position to turn the headlight on.

WARNING! Do not attach a large key fob or key ring to the main switch. It may contact the gas tank cap when turning, causing an interruption to the electrical system and an unexpected engine shut-down during operation.

Start Switch

Press the start switch toward the handlebar to engage the starter.

Tip: The starter will not engage unless the rear brakes are applied. See page 32 for engine starting procedures.

FEATURES AND CONTROLS

Switches and Levers

Light Switch

Use the headlight switch to change the lights from high beam to low beam. Move the main key switch to the LIGHTS ON position to turn the headlight on.

Choke Lever

The choke assists in starting a cold engine. See page 32.

Horn Switch

 Press the horn button to alert others of your presence.

Hazard Warning Switch

 Push the hazard warning switch to cause all turn indicators to flash simultaneously. Use this feature to alert others of an emergency or other situation requiring caution.

Turn Signal Switch

 Move the switch either left or right to activate the corresponding turn signal. Return the switch to the center position to end the signal.

FEATURES AND CONTROLS

Switches and Levers

Throttle Lever

Press the throttle lever to increase engine speed and vehicle movement. Release the lever to reduce engine speed and vehicle movement.

WARNING! Failure to check or maintain proper operation of the throttle system can result in an accident if the throttle lever sticks during operation. Check the lever for proper operation before starting the engine. Check occasionally during operation.

Do not start or operate a Quadricycle with sticking or improperly operating throttle controls.

Contact your dealer for repair if throttle problems arise.

The Electronic Throttle Control (ETC) stops the engine in the event of a throttle system malfunction. Do not modify the ETC system or replace it with other throttle mechanisms.

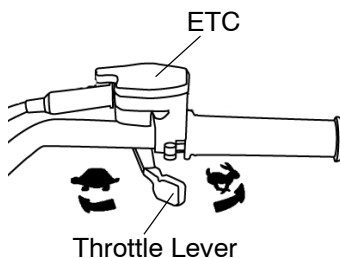

Rear Brake Lever

The brake lever operates the rear brakes only. Squeeze the brake lever toward the handlebar to apply the rear brakes.

Since the brake lever operates the rear brakes only, it is not as effective as the all-wheel foot brake.

If the rear wheels begin to skid or slide while using this brake, *reduce* lever pressure.

WARNING! Aggressively applying the rear brake when backing down a hill may cause rear tipover. Aggressively applying the rear brake while moving forward may cause the rear wheels to skid and result in loss of control.

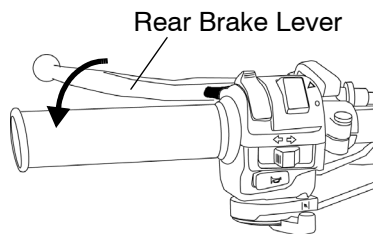

FEATURES AND CONTROLS

Foot Brake

The all-wheel foot brake is located on the right footrest. Press the brake pedal forward with your foot to engage all four brakes, providing maximum stopping power.

Inspect and maintain the brake fluid level as outlined in this manual. See page 58.



Foot Brake

Parking Brake

1. Squeeze the brake lever.
2. Push the parking brake lock down to engage the lock.
3. Release the brake lever.
4. To release the parking brake lock, squeeze and release the brake lever. The parking brake will release automatically.

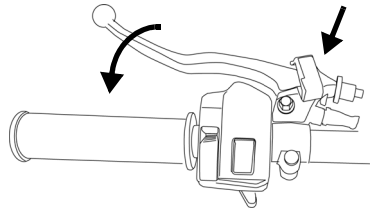

WARNING! Operating the vehicle while the parking brake is engaged could result in an accident or fire. Always check to be sure the parking brake is disengaged before operating.

The parking brake may relax if left on for a long period of time. Always block the wheels to prevent rolling. Never depend on the parking brake alone if the vehicle is parked on a hill. Always block the wheels to prevent rolling.

FEATURES AND CONTROLS

Indicator Lights

View vehicle functions on the instrument panel. Each light illuminates when the feature is activated.

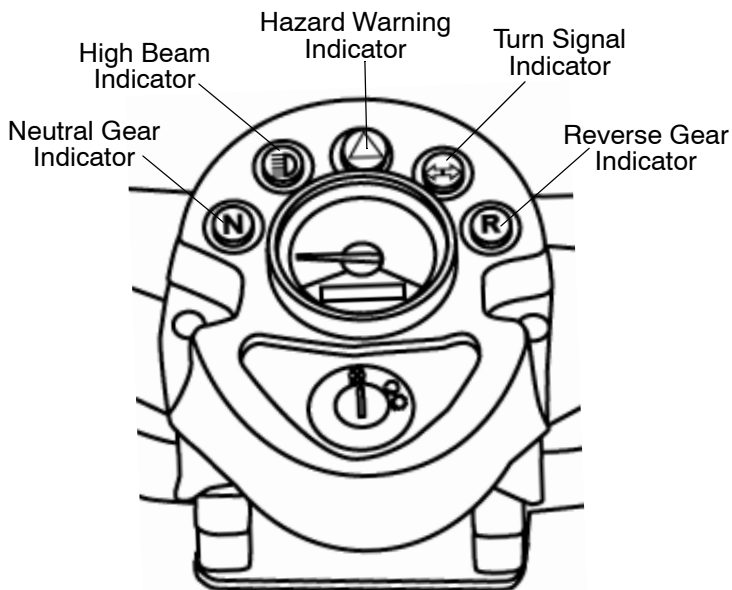

Mirrors

Use the mirrors to assist in traffic maneuvers. Always check and adjust the mirrors before driving the Quadricycle.

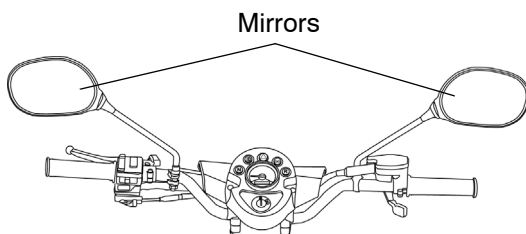

FEATURES AND CONTROLS

Fuel Tank Cap

Always refuel with the engine stopped, and outdoors or in a well ventilated area. Refuel on a level surface.

Remove the fuel tank cap to add fuel to the fuel tank. The gauge in the cap shows the approximate amount of fuel remaining. Use either leaded or unleaded gasoline with a minimum pump octane number of 87=(R+ M/2) octane. *Do not use E-85 fuel.*

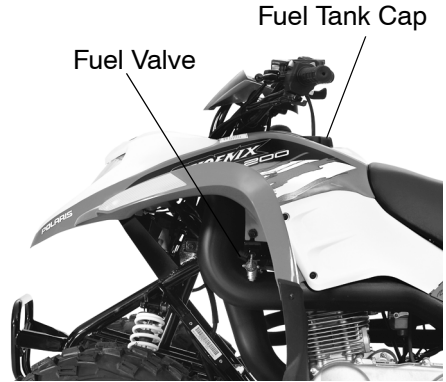

Fuel Valve

The fuel valve is located on the left side of the vehicle.

ON: For normal operation.

OFF: For vehicle storage and when transporting.

RES: Turn the valve to the reserve setting if the main fuel supply is exhausted.

Refuel as soon as possible. Return the valve to the ON position after refueling.

Reserve fuel range is about 7-10 miles (11-16 km).

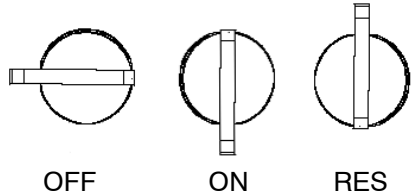

FEATURES AND CONTROLS

Transmission Gear Selector

The transmission gear selector is located on the right side of the vehicle.

R: Reverse

N: Neutral

F: Forward Gear

To shift gears, brake to a complete stop. When the engine is idling, move the lever to the desired gear.

Gear Selector

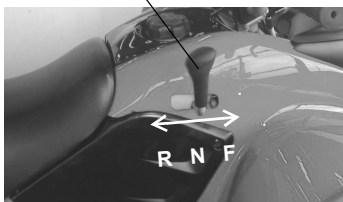

NOTICE: Shifting gears with the engine speed above idle or while the vehicle is moving could cause transmission damage.

Whenever the vehicle is left unattended, always place the transmission in gear and lock the parking brake.

Kick-Start Lever

If the battery is too weak to start the engine, use the kick-start lever to start the engine until the battery is serviced.

1. Position the vehicle on a level surface.
2. Lock the parking brake.
3. Place the transmission in neutral.
4. Fold out the kick-start lever on the left side of the vehicle.
5. Make sure the main key switch is on.
6. Place your foot on the kick-start lever. Thrust your heel downward to crank the engine.
7. If the engine is cold, use the choke as outlined on page 32.
8. After the engine has started, fold the kick-start lever back into place.

Tip: A 10/12 mm wrench is provided in the tool kit for removing or installing the lever. If not installed, make sure the rubber cap is installed on the kick-start shaft to protect the rider. The storage area for the kick-start lever is on the left side of the frame above the rear swing arm pivot.

⚠ WARNING

Failure to operate the vehicle properly can result in a collision, loss of control, accident or overturn, which may result in serious injury or death. Read and understand all safety warnings outlined in the safety section of this owner's manual.

Break-In Period

The break-in period for your new Polaris Quadricycle is the first ten hours of operation, or the time it takes to use the first two full tanks of gasoline. No single action on your part is as important as following the procedures for a proper break-in. Careful treatment of a new engine and drive components will result in more efficient performance and longer life for these components.

NOTICE: Do not operate at full throttle or high speeds during the first three hours of use.

Engine and Drivetrain Break-in

1. Fill the fuel tank with gasoline. See page 27. Always exercise extreme caution whenever handling gasoline.
2. Check the oil level. See page 52. Add oil as needed to maintain the level in the proper range.
3. Drive slowly at first. Select an open area that allows room to familiarize yourself with vehicle operation and handling.
4. Vary the throttle positions. Do not operate at sustained idle.
5. Perform regular checks on fluid levels, controls and areas outlined on the daily pre-ride inspection checklist. See page 31.
6. Pull only light loads (if equipped with a hitch).
7. Change both the oil and the filter at 20 hours or one month, whichever comes first.

OPERATION

Safe Operation Practices

1. Complete the recommended safety training before operating this vehicle. See page 7.
2. Do not allow anyone under 16 years of age to operate this vehicle. Do not allow anyone with cognitive or physical disabilities to operate this vehicle.
3. Never carry a passenger on this vehicle.
4. Engine exhaust fumes are poisonous. Never start the engine or let it run in an enclosed area.
5. Avoid sudden turns or swift movement of the handlebars when operating on pavement.
6. Use caution and drive at reduced speeds in conditions of reduced visibility such as fog, rain and darkness. Clean headlights frequently and replace burned out headlamps promptly.
7. Drive in a manner appropriate for your skills and operating conditions. Never operate at excessive speeds. Never attempt wheelies, jumps, or other stunts. Never remove your hands from the handlebars while operating, and always keep both feet on the footrests.
8. Never consume alcohol or drugs before or while operating this vehicle.
9. Always use the size and type of tires specified for your vehicle. Always maintain proper tire pressure.
10. Never operate a damaged Quadricycle. After any overturn or accident, have a qualified service dealer inspect the entire machine for possible damage.
11. Never operate the vehicle on a frozen body of water.
12. Familiarize yourself with all laws and regulations concerning the operation of this vehicle in your area.
13. Do not touch hot exhaust system components. Always keep combustible materials away from the exhaust system.
14. Always remove the ignition key when the vehicle is not in use to prevent unauthorized use.

Pre-Ride Checklist

Failure to inspect and verify that the ATV is in safe operating condition before operating increases the risk of an accident. Always inspect the ATV before each use to make sure it's in safe operating condition.

Item	Remarks	Page
Brake system/lever travel	Ensure proper operation	58 59
Brake fluid	Ensure proper level	58
Foot brake	Ensure proper operation	25
Front suspension	Inspect, lubricate if necessary	51
Rear suspension	Inspect, lubricate if necessary	51
Steering	Ensure free operation	-
Tires	Inspect condition and pressure	65
Wheels/fasteners	Inspect, ensure fastener tightness	65
Frame nuts, bolts, fasteners	Inspect, ensure tightness	-
Fuel and oil	Ensure proper levels	27 52
Throttle	Ensure proper operation	24 64
Indicator lights/switches	Ensure operation	22
Air filter, pre-filter	Inspect, clean	67
Air box sediment tube	Drain deposits whenever visible	-
Headlamp	Check operation, apply Polaris dielectric grease when lamp is replaced	23 70
Brake light/tail lamp	Check operation, apply Polaris dielectric grease when lamp is replaced	70
Riding gear	Wear approved helmet, goggles, and protective clothing	8

OPERATION

Starting the Engine

1. Position the vehicle on a level surface outdoors or in a well-ventilated area.
2. Sit on the vehicle.
3. Turn the fuel valve on.
4. Turn the main key switch on.
5. Squeeze the brake lever.

Tip: Do not use the choke if starting a warm engine.

6. If the engine is cold, move the choke lever to the left until it stops.

Tip: The choke is fully on when the lever is completely to the left. The choke is off when the lever is completely to the right. The choke can be adjusted gradually, depending on how much choke is needed for starting.

7. Press the start switch.
8. Do not press the throttle while starting the engine.

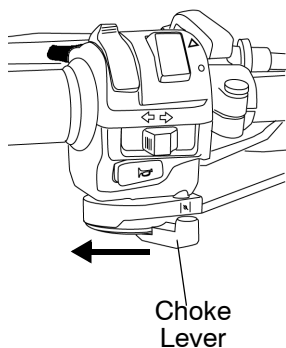

Starting the Engine

9. Activate the starter for a maximum of five seconds. Release the start switch when the engine starts.

NOTICE: Operating the vehicle immediately after starting could cause engine damage. Allow the engine to warm up for several minutes before operating the vehicle.

10. If the engine does not start, release the start switch, wait five seconds, then attempt to start again. Repeat this procedure until the engine starts.
11. If the engine slows or stops, move the choke lever half way to the right to allow proper engine warm-up. Vary the engine RPM slightly with the throttle to aid in warm-up.
12. When the engine idles smoothly, move the choke lever completely to the right.

Cold Weather Operation

If the vehicle is used year-round, check the oil level frequently. A rising oil level could indicate condensation in the bottom of the crankcase, which can lead to engine damage. Any condensation must be drained.

Tip: Internal engine condensation increases as outside temperature decreases.

If the oil level rises to the top of the sight glass, change the oil immediately. Always operate the engine long enough to reach operating temperature, which reduces condensation.

OPERATION

Driving Procedures



1. Wear a helmet and eye protection. See page 8.
2. Sit upright. Keep your feet on the footrests. Keep both hands on the handlebars.
3. Squeeze the brake lever.
4. Start the engine and allow it to warm up.
5. Shift the transmission into gear.
6. Check your surroundings and determine your path of travel.
7. Release the brake lever.
8. Slowly squeeze the throttle lever toward the handlebar to begin driving. Squeeze the throttle lever further to increase speed.
9. Drive slowly. Practice maneuvering and using the throttle and brakes on level surfaces.

Turning the Vehicle

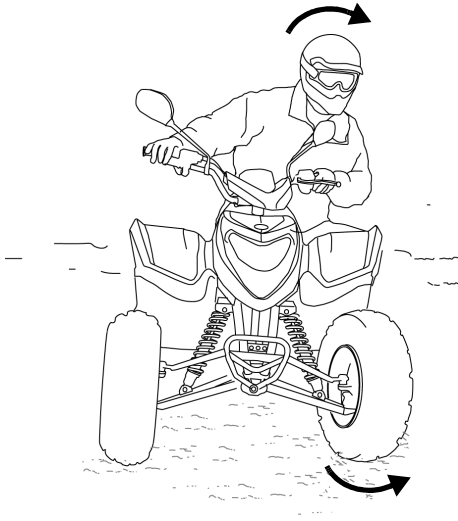

To turn, steer in the direction of the turn, leaning your upper body to the inside of the turn while supporting your weight on the outer footrest. The same leaning technique should be used for turning in reverse.

Practice making turns at slow speeds before attempting to turn at faster speeds.

WARNING! Turning improperly can result in vehicle overturn. Never turn abruptly or at sharp angles. Never turn at high speeds.

OPERATION

Driving on Slippery Surfaces

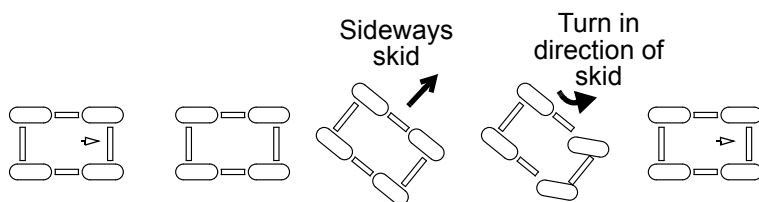
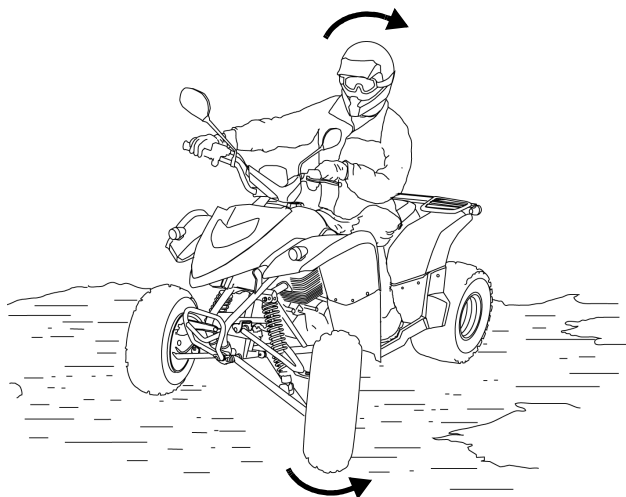

Whenever riding on slippery surfaces such as wet trails or loose gravel, or during freezing weather, follow these precautions:

1. Do not operate on excessively rough, slippery or loose terrain.
2. Slow down before driving onto slippery surfaces.
3. Be alert. Watch the trail. Avoid quick, sharp turns.
4. Never apply the brakes during a skid. To correct a rear wheel skid, turn the handlebars in the same direction as the skid and shift body weight forward.

Driving Uphill

Braking and handling are greatly affected when operating in hilly terrain. Improper procedure could cause loss of control or overturn. Whenever traveling uphill, follow these precautions:

1. Drive straight uphill.
2. Avoid steep hills (25° maximum).
3. Always check the terrain carefully before ascending any hill.
4. Avoid hills with excessively slippery or loose surfaces.
5. Keep both feet on the footrests.
6. Shift body weight uphill.
7. Drive at a steady rate of speed to avoid stalling.
8. Never open the throttle suddenly or make sudden gear changes.
9. Never go over the top of a hill at high speed.
10. Be alert. Be prepared to take emergency action. This may include dismounting quickly.

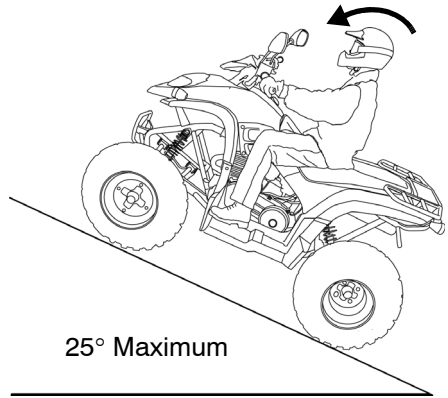

If all forward speed is lost:

Keep your weight uphill.

If the vehicle begins rolling downhill, never apply engine power. Never apply the rear brakes while rolling backwards.

Apply the foot brake gradually. When fully stopped, squeeze the brake lever as well.

Dismount on the uphill side, or to either side if the vehicle is pointed straight uphill. Turn the vehicle around and remount, following the procedure described on page 40.

OPERATION

Driving on a Sidehill (Sidehilling)



Driving on a sidehill is not recommended. Improper procedure could cause loss of control or overturn. Avoid crossing the side of any hill unless absolutely necessary.

If crossing a sidehill is *unavoidable*, follow these precautions:

1. Slow down.
2. Avoid hills with excessively slippery or loose surfaces.
3. Avoid crossing the side of a steep hill.
4. Shift body weight uphill.
5. Keep your feet on the footrests.
6. If the vehicle begins to tip, quickly turn the front wheel downhill, if possible, or dismount on the uphill side *immediately!*

Driving Downhill

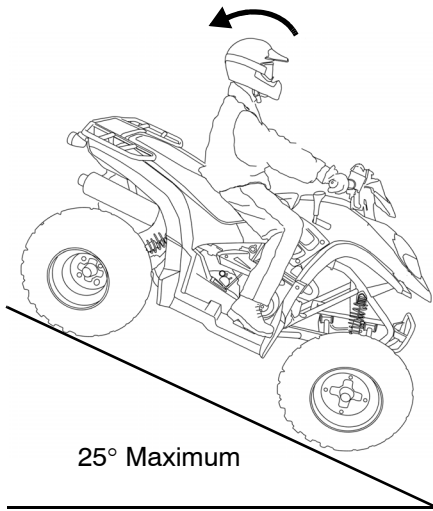

When driving downhill, follow these precautions:

1. Avoid steep hills (25° maximum).
2. Avoid hills with excessively slippery or loose surfaces.
3. Shift body weight uphill.
4. Drive straight downhill.
5. Slow down. Never go down a hill at high speed.
6. Avoid going down a hill at an angle, which can cause the vehicle to pitch sharply to one side.
7. Apply the brakes *slightly* to aid in slowing.

OPERATION

Turning Around on a Hill (K-Turn)

If the vehicle stalls while climbing a hill, never back it down the hill!
Use the K-turn to turn around.

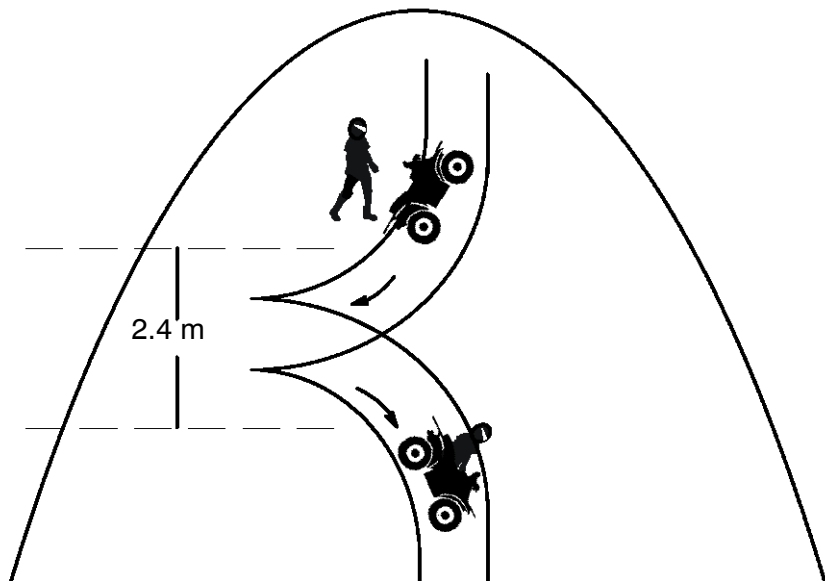

1. Apply the all-wheel foot brake to stop the vehicle.
2. Keep your weight uphill.
3. Squeeze and hold the brake lever while completing steps 4-6.
4. Leave the transmission in forward and shut off the engine.
5. Dismount on the uphill side of the vehicle, or on the left if the vehicle is pointing straight uphill.
6. Staying uphill of the vehicle, turn the handlebars full left.
7. Slowly release the brake lever and allow the vehicle to roll around to your right until it's pointing across the hill or slightly downward.
8. Squeeze the brake lever. Remount from the uphill side. Keep your weight uphill.
9. With the transmission still in forward, start the engine
10. Release the brake lever and drive *slowly* downhill. Control speed with the brake lever until the vehicle is on level ground.

Driving Through Water

Your ATV can operate through water with a maximum recommended depth equal to the bottom of the footrests. Follow these procedures when operating through water:

1. Determine water depths and current before entering water.
2. Choose a crossing where both banks have gradual inclines.
3. Avoid operating through deep or fast-flowing water.



Maximum Depth

NOTICE: Major engine damage can result if the vehicle is not thoroughly inspected after operation in water. If the vehicle tips or overturns in water, or if the engine stops during or after operating in water, restarting can result in serious engine damage. Transport the vehicle to your dealer for service before restarting the engine. If this is not possible, follow the vehicle immersion inspection and drying procedures outlined on page 71, then see your dealer for service at the first opportunity.

4. After leaving water, test the brakes. Apply them lightly several times while driving slowly. The friction will help dry out the pads.

If it's unavoidable to enter water deeper than the footrest level:

- Proceed slowly. Avoid rocks and obstacles.
- Balance your weight carefully. Avoid sudden movements.
- Maintain a steady rate of speed. Do not make sudden turns or stops. Do not make sudden throttle changes.

OPERATION

Driving Over Obstacles

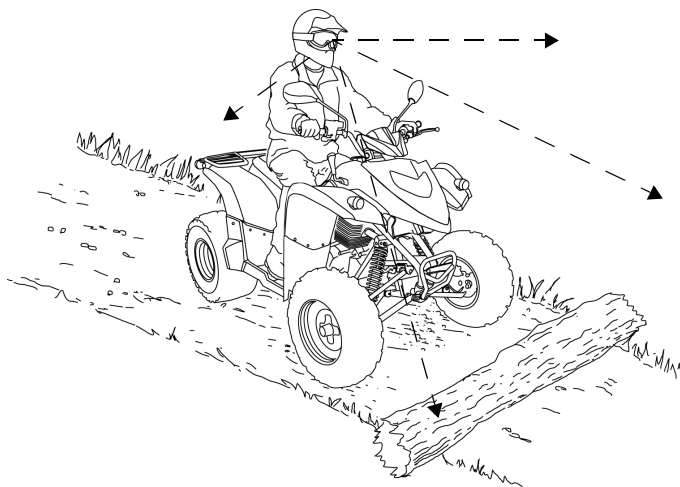

Follow these precautions when operating over obstacles:

1. Always check for obstacles before operating in a new area.
2. Be alert. Watch the terrain. Use extra caution
3. Never operate over large obstacles.
4. Avoid hazards such as logs, rocks and low branches.

Driving in Reverse

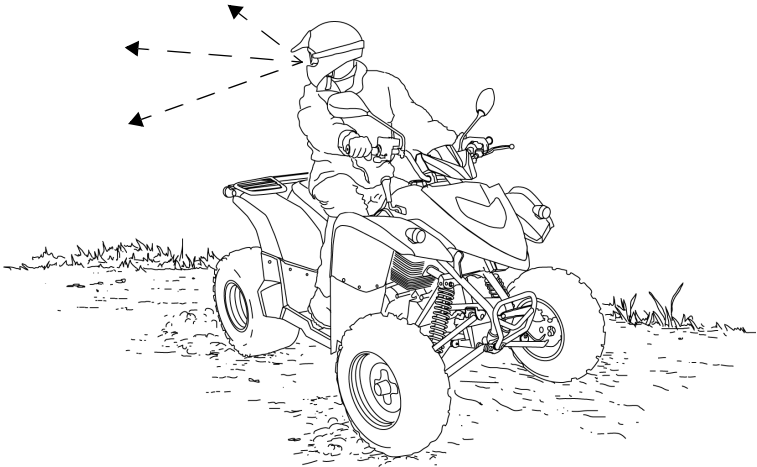

Follow these precautions when operating in reverse:

1. Always check for obstacles or people behind the vehicle.
2. Always avoid backing downhill.
3. Back slowly.
4. Apply the brakes *lightly* for stopping.
5. Avoid turning at sharp angles.
6. Never open the throttle suddenly.

OPERATION

Hauling Cargo

⚠ WARNING

Overloading the vehicle or carrying or towing cargo improperly can alter vehicle handling and may cause loss of control or brake instability, which can result in serious injury or death. Always follow these precautions when hauling cargo:

REDUCE SPEED AND ALLOW GREATER DISTANCES FOR BRAKING WHEN HAULING CARGO.

NEVER EXCEED THE MAXIMUM WEIGHT CAPACITY of the vehicle. When determining the weight you are adding to the vehicle, include the weight of the operator, accessories, loads in the rack or box and the load on the trailer tongue. The combined weight of these items must not exceed the maximum weight capacity.

When operating over rough or hilly terrain, reduce speed and cargo to maintain stable driving conditions.

CARRY LOAD AS LOW ON THE RACK AS POSSIBLE. Carrying a load high on the rack raises the center of gravity of the vehicle and creates a less stable operating condition.

SECURE ALL LOADS BEFORE OPERATING. Unsecured loads can create unstable operating conditions, which could result in loss of control of the vehicle.

OPERATE ONLY WITH STABLE AND SAFELY ARRANGED LOADS. When handling off-centered loads that cannot be centered, securely fasten the load and operate with extra caution. Always attach the tow load to the hitch point designated for your vehicle.

HEAVY LOADS CAN CAUSE BRAKING AND CONTROL PROBLEMS. Use extreme caution when applying brakes with a loaded vehicle. Avoid terrain or situations that may require backing downhill.

USE EXTREME CAUTION when operating with loads that extend over the rack sides. Stability and maneuverability may be adversely affected, causing the vehicle to overturn.

NEVER CARRY CARGO ON THE FRONT OF THE VEHICLE.

DO NOT TRAVEL FASTER THAN THE RECOMMENDED SPEEDS. Vehicle should never exceed 10 mph (16 kph) while towing a load on a level surface. Vehicle speed should never exceed 5 mph (8 kph) when towing loads in rough terrain, while cornering, or while ascending or descending a hill.

Hauling Cargo

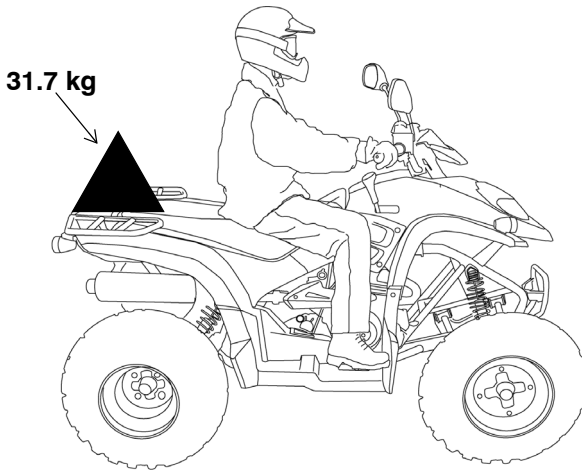

Load Distribution

Read and understand the load distribution warnings listed on the vehicle warning labels. Never exceed the specified weights. Your Quadricycle may carry a maximum of 31.7 kg of cargo on the rear rack. It may tow a maximum of 136 kg with a maximum tongue weight of 13.6 kg.

Load cargo as low as possible. Never carry cargo on the front of the vehicle. When operating over rough or hilly terrain, reduce cargo and drive slowly to maintain stable driving conditions.

Slow down. Operate with extreme caution when hauling cargo or towing loads. Balance, handling and control may be affected.

Towing

Towing is approved OFF-ROAD ONLY. Operating a Quadricycle/trailer combination on public roads is prohibited. Do not exceed the maximum capacities when towing. Do not tow any trailer on a grade steeper than 15°.

Phoenix 200 Quadricycle	Maximum Towed Load (Level Ground)	Maximum Vertical Hitch Weight
	136 kg	13.6 kg

OPERATION

Parking on an Incline

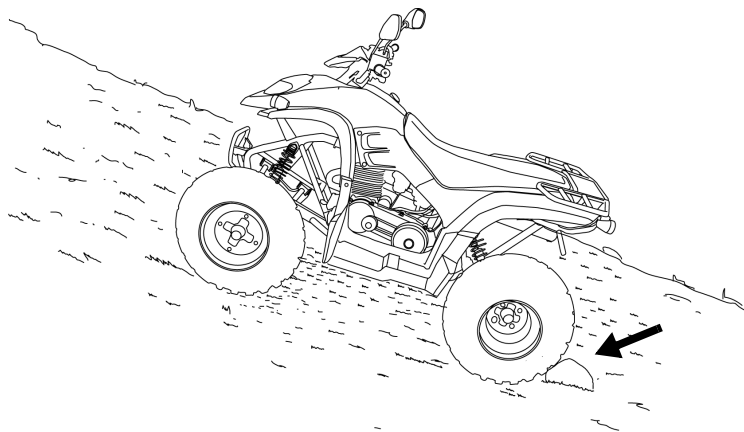

Avoid parking on an incline. If it's unavoidable, follow these precautions:

1. Stop the engine.
2. Place the transmission in gear.
3. Lock the parking brake.
4. Always block the rear wheels on the downhill side.
5. Turn the fuel valve off.

EMISSION CONTROL SYSTEMS

This vehicle complies with the requirements of European directive 97/24/EC.

Noise Emission Control System

Do not modify the engine, intake or exhaust components, as doing so may affect compliance with governmental noise level requirements.

Exhaust Emission Control System

The emissions from the exhaust of this vehicle are controlled by engine design, including factory-set fuel delivery and ignition. The engine and related components must be maintained at Polaris specifications to achieve optimal performance.

Engine idle speed is the only adjustment Polaris recommends that the operator perform. Any other adjustments should be performed by an authorized Polaris dealer.

MAINTENANCE

Periodic Maintenance Chart

Maintenance intervals in the following chart are based upon average riding conditions. Vehicles subjected to severe use must be inspected and serviced more frequently.

Service and adjustments are important for proper vehicle operation. If you're not familiar with safe service and adjustment procedures, have a qualified dealer perform these operations. Record maintenance and service in the Maintenance Log beginning on page 90.

Severe Use Definition

- Frequent immersion in mud, water or sand
- Racing or race-style high RPM use
- Prolonged low speed, heavy load operation
- Extended idle
- Short trip cold weather operation

WARNING

Improperly performing the procedures marked with a ■ could result in component failure and cause an accident, which may result in serious injury or death. Always have an authorized Polaris dealer perform these services.

Maintenance Chart Key

- ▶ Perform these operations more often for vehicles subjected to severe use.
- E Emission-related service (Failure to conduct this maintenance will not void the emissions warranty but may affect emissions.)
- Have an authorized Polaris dealer perform these services.

MAINTENANCE

Periodic Maintenance Chart

Perform all services at whichever maintenance interval is reached first.

Item		Maintenance Interval (whichever comes first)			Remarks
		Hours	Calendar	Kilometers	
■	Steering	-	Pre-Ride	-	Make adjustments as needed. See Pre-Ride Checklist on page 31.
▶	Front suspension	-	Pre-Ride	-	
▶	Rear suspension	-	Pre-Ride	-	
	Tires	-	Pre-Ride	-	
▶	Brake fluid level	-	Pre-Ride	-	
▶	Brake lever travel	-	Pre-Ride	-	
	Brake system	-	Pre-Ride	-	
	Wheels/fasteners	-	Pre-Ride	-	
	Frame fasteners	-	Pre-Ride	-	
▶	Engine oil level	-	Pre-Ride	-	
▶ E	Air filter, pre-filter	-	Daily	-	Inspect; clean often; replace as needed
▶	Air box sediment tube	-	Daily	-	Drain deposits when visible
	Headlamp/tail lamp	-	Daily	-	Check operation; apply dielectric grease if replacing
▶ E	Air filter, main element	-	Weekly	-	Inspect; replace as needed
▶ ■	Brake pad wear	10	Monthly	100	Inspect periodically
	Battery	20	Monthly	200	Check terminals; clean; test
▶	Front gearcase oil (if equipped)	25	Monthly	250	Inspect level; change yearly
▶	Transmission oil	25	Monthly	250	Inspect level; change yearly
▶ E	Engine breather filter (if equipped)	25	Monthly	250	Inspect; clean if needed
▶ E	Engine oil change (break-in)	25	1 M	250	Perform a break-in oil change
▶	General lubrication	50	3 M	500	Lubricate all fittings, pivots, cables, etc.
	Carburetor float bowl	50	6 M	500	Drain bowl periodically and prior to storage
■ E	Throttle Cable/ETC Switch	50	6 M	500	Inspect; adjust; lubricate; replace if necessary

▶ Perform these procedures more often for vehicles subjected to severe use.

E Emission-Related Service

■ Have an authorized Polaris dealer perform these services.

MAINTENANCE

Periodic Maintenance Chart

	Item	Maintenance Interval (whichever comes first)			Remarks
		Hours	Calendar	Miles (Km)	
■ E	Choke cable	50	6 M	500	Inspect; adjust; lubricate; replace if necessary
E	Carburetor air intake ducts/flange	50	6 M	500	Inspect duct for proper sealing/air leaks
	Drive belt	50	6 M	500	Inspect; adjust; replace as needed
	Shift linkage	50	6 M	500	Inspect; lubricate; adjust
■	Steering	50	6 M	500	Lubricate
▶	Front suspension	50	6 M	500	Lubricate
▶	Rear suspension	50	6 M	500	Lubricate
▶ E	Engine oil change	100	6 M	1000	Perform a break-in oil change at 20 hours
▶ E	Oil filter change	100	6 M	1000	Replace with oil change
■ E	Valve clearance	100	12 M	1000	Inspect; adjust
■ E	Fuel system/filter	100	12 M	1000	Check for leaks at tank cap, lines, fuel valve, filter, pump, carburetor; replace lines every two years
▶	Engine mounts	100	12 M	1000	Inspect
	Exhaust muffler/pipe	100	12 M	1000	Inspect
■ E	Spark plug	100	12 M	1000	Inspect; replace as needed
■ E	Ignition Timing	100	12 M	1000	Inspect
▶	Wiring	100	12 M	1000	Inspect for wear, routing, security; apply dielectric grease to connectors subjected to water, mud, etc.
■	Clutches (drive and driven)	100	12 M	1000	Inspect; clean; replace worn parts
■	Front wheel bearings	100	12 M	1000	Inspect; replace as needed
■	Brake fluid	200	24 M	2000	Change every two years
E	Idle speed	-			Adjust as needed
■	Toe adjustment	-			Inspect periodically; adjust when parts are replaced
	Headlight aim	-			Adjust as needed

Lubrication Guide

Check and lubricate all components at the intervals outlined in the Periodic Maintenance Chart beginning on page 48. Items not listed in the chart should be lubricated at the General Lubrication interval.

Item	Lube	Method
Engine Oil	PS-4 PLUS Performance Synthetic 2W-50	See page 52.
Brake Fluid	DOT 4 Only	See page 58.
Transmission Oil	Polaris AGL Synthetic Gearcase Lube	See page 55.
Rear Gearcase	Premium Angle Drive Fluid	See page 56.
Front A-Arms	Polaris Premium U-Joint Lube	Inspect; tighten fasteners; grease (also after washing vehicle or driving in water)

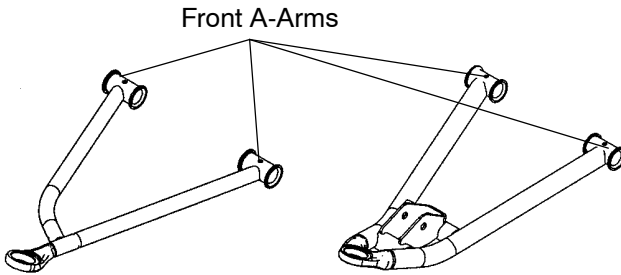

MAINTENANCE

Engine Oil

Oil Recommendations

Polaris recommends the use of Polaris PS-4 *PLUS Performance* Synthetic 2W-50 4-cycle oil or a similar oil for this engine. Oil may need to be changed more frequently if Polaris oil is not used. Always use 2W-50 oil. Follow the manufacturer's recommendations for ambient temperature operation.

NOTICE: Mixing brands or using a non-recommended oil may cause serious engine damage. Always use the recommended oil. Never substitute or mix oil brands.

Oil Specifications

Lubricant	Capacity	Drain Plug Torque
PS-4 PLUS Performance Synthetic 2W-50 4-Cycle Oil	1200 ml	15 Nm

Oil Level

Maintain the oil level at the center of the sight glass. Do not overfill.

NOTICE: A rising oil level between checks in cool weather driving can indicate contaminants such as gas or moisture collecting in the crankcase. If the oil level rises to the top of the sight glass, change the oil immediately.

1. Position the vehicle on a level surface.
2. Start the engine. Allow it to idle for 30 seconds. Stop the engine.
3. View the oil level through the sight glass.
4. Remove the fill plug. Add the recommended oil as needed.
5. Reinstall the fill plug securely.

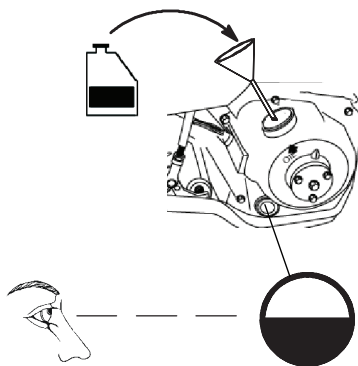

Oil and Filter Change

Always change the oil and filter at the intervals outlined in the Periodic Maintenance Chart beginning on page 48. Always change the oil filter whenever changing oil. Change the oil more often if the vehicle is routinely subjected to:

- operation in dusty or wet conditions.
- operation when air temperature is below -12°C .
- short trips at -12° to -1°C . (engine fails to reach operating temperature).

NOTICE: If the vehicle is left without oil in the system for extended periods, the oil pump may lose its prime, which could result in engine damage. Always replace the oil and filter within a few hours of draining the oil. Do not allow the vehicle to be without oil overnight.

-
1. Use Polaris-recommended products.
 2. Position the vehicle on a level surface.
 3. Start the engine. Allow it to idle for two minutes. Stop the engine.
 4. Place a drain pan beneath the engine crankcase. Remove the drain plug. Allow the oil to drain completely.



Hot oil can cause burns to skin. Do not allow hot oil to contact skin.

5. Reinstall the drain plug with a new sealing washer.
6. Reinstall the drain plug. Torque to specification (see page 52).

MAINTENANCE

Oil and Filter Change

7. Place towels under the oil filter. Using an oil filter wrench, turn the filter counterclockwise to remove it.
8. Clean the filter sealing surface on the crankcase.
9. Lubricate the filter o-ring.

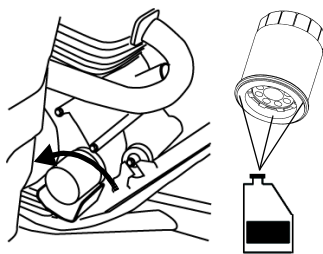

10. Install the new oil filter. After the filter contacts the engine surface, turn it 1/2 turn by hand.

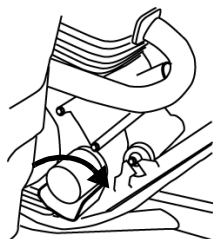

11. Remove the oil fill plug. Add 850 ml of the recommended oil (see page 52).
12. Reinstall the fill plug.
13. Start the engine. Allow it to idle for two minutes. Stop the engine.
14. Check for oil leaks.
15. Check the oil level. Add oil as needed.
16. Discard used oil and filter properly.

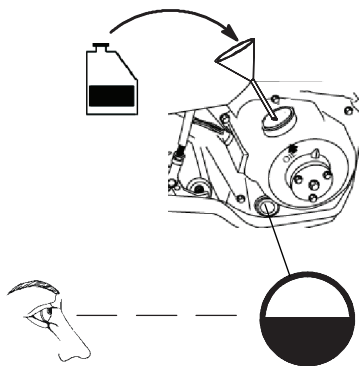

Transmission Oil

Always check and change the transmission oil at the intervals outlined in the Periodic Maintenance Chart beginning on page 48.

Transmission Oil Recommendations

Gearcase	Lubricant	Capacity	Drain Plug Torque
Transmission	Premium AGL Synthetic Gearcase Lubricant	550 ml	24 Nm

Oil Check

1. Position the vehicle on a level surface. Place the transmission in gear. Lock the parking brake.
2. View the oil level through the sight glass. The oil level should be between 1/4 and 3/4.
3. Remove the fill plug. Add the recommended oil as needed.
4. Reinstall the fill plug.

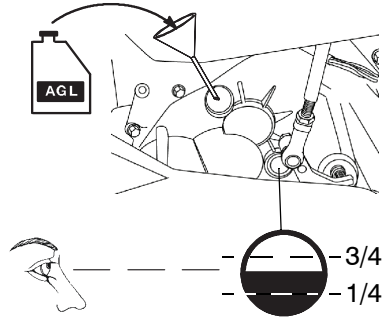

Oil Change

1. Position the vehicle on a level surface. Place the transmission in gear. Lock the parking brake.
2. Remove the fill plug.
3. Remove the transmission drain plug.
4. Drain the fluid into a drain pan.
5. Clean and reinstall the drain plug. Torque to specification.
6. Add 550 ml of the recommended fluid.
7. Reinstall the fill plug.
8. Check for leaks. Discard used oil properly.

MAINTENANCE

Rear Gearcase Oil

Always check and change the rear gearcase oil at the intervals outlined in the Periodic Maintenance Chart beginning on page 48.

Rear Gearcase Oil Recommendations

Gearcase	Lubricant	Capacity	Fill Plug Torque	Drain/Check Plug Torque
Rear Gearcase	Premium ATV Angle Drive Fluid	120 ml	34 Nm	24 Nm

Oil Check

1. Position the vehicle on a level surface. Place the transmission in gear. Lock the parking brake.
2. Remove the check plug. View the oil level. The oil level should be at the bottom of the plug hole.
3. Remove the fill plug. Add the recommended fluid as needed.
4. Reinstall the fill plug. Torque to specification.
5. Reinstall the check plug. Torque to specification.

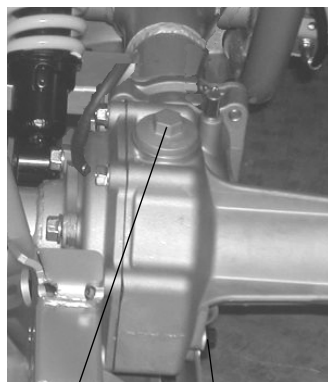

Fill Plug Check Plug

Oil Change

1. Remove the skid plate.
2. Remove the drain plug. Drain the fluid into a drain pan.
3. Clean and reinstall the drain plug with a new sealing washer. Torque to specification.
4. Remove the fill plug. Add 120 ml of the recommended fluid.
5. Reinstall the fill plug. Torque to specification.
6. Check for leaks.
7. Reinstall the skid plate. Discard used oil properly.

Brakes

⚠ WARNING

An over-full master cylinder may cause brake drag or brake lock-up, which could result in an accident. Maintain brake fluid at the recommended level. Do not overfill.

Once open, a bottle of brake fluid absorbs moisture from the air, which causes the boiling temperature of the brake fluid to drop. This can lead to early brake fade and the possibility of accident. Do not store opened brake fluid. Properly discard any unused portion.

Under normal operation, a diaphragm extends into the reservoir as fluid level drops. If the fluid level is low and the diaphragm is not extended, a leak is likely. The brake system should be inspected by your dealer. Fill the reservoir as needed whenever the cover is loosened or removed to ensure proper diaphragm operation. Use Polaris DOT 4 brake fluid. Do not overfill.

Reservoir levels will decrease as brake pads become worn. When checking the fluid level, the vehicle must be on level ground with the handlebars straight. If the fluid level is low, check brake pad thickness before adding brake fluid. *Do not overfill.*

MAINTENANCE

Brakes

Brake Check

Perform the following checks to keep the brake systems in good operating condition. Check more often if brakes are used heavily during normal operation.

1. Always keep foot brake fluid at an adequate level. Check the foot brake system regularly for fluid leaks.
2. Check the brakes for excessive travel or spongy feel.
3. Check the brake pads for wear, damage or looseness. Replace pads when they are worn to 1 mm.
4. Check the security and surface condition of the brake discs.

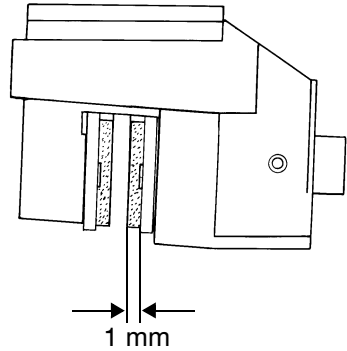

Brake Fluid (Foot Brake)

Check brake fluid level before each use of the vehicle.

The brakes should feel firm when they're applied. Spongy or weak brakes may indicate a fluid leak or low fluid level. A low fluid level may also mean that brake pads are worn and need to be replaced. Do not operate the vehicle with spongy or weak brakes. See your dealer for service.

1. Locate the foot brake master cylinder under the right rear fender.
2. View the fluid level through the reservoir body.
3. Fluid level is full at the MAX mark. Add brake fluid if the level reaches the MIN mark.

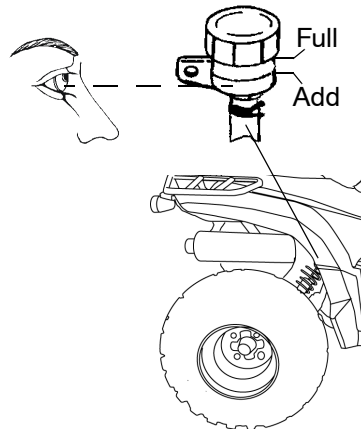

Brakes

Brake Lever Travel

Service the brakes when brake lever travel reaches 65 mm. Always service the brakes when there is no longer sufficient stopping ability at the specified lever travel setting.

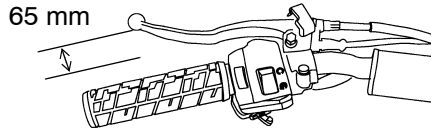

Brake Freeplay

Periodically measure the freeplay of the rear brakes. Acceptable freeplay range is 10-20 mm.

To adjust rear brake freeplay, turn the adjuster nut at the rear brake drum.

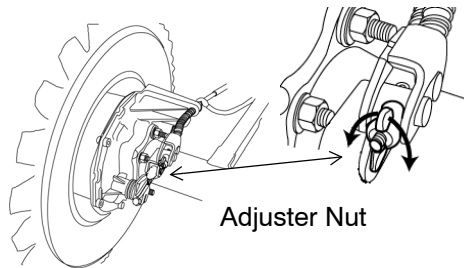
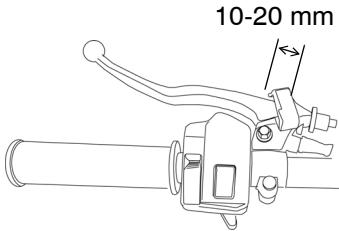

MAINTENANCE

Toe Alignment

Use the following procedure to check the toe alignment of the vehicle. The recommended toe alignment is 3-6 mm toe out.

1. Position the vehicle on a level surface.
2. Set the handlebars in a straight-ahead position and secure them in this position.
3. Place a chalk mark on the center line of the front tires approximately 25 cm from the floor, or as close to the hub/axle center line as possible. Make sure both marks are the same distance from the floor.
4. Measure the distance between the marks and record the measurement (1).
5. Move the vehicle until the chalk marks are at the rear of the tires, even with the hub/axle center line.
6. Measure the distance between the marks and record the measurement (2).
7. Subtract measurement 2 from measurement 1. The difference is the vehicle toe-out alignment.
8. If you discover improper alignment, see your Polaris dealer for service.

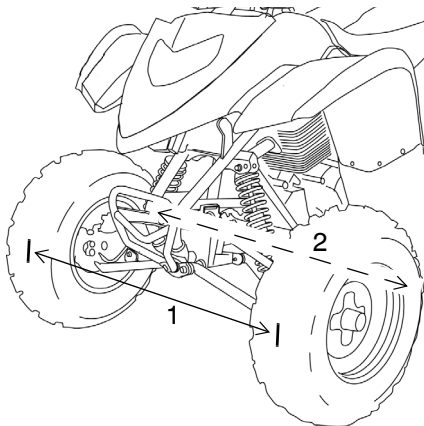

Steering Assembly

Check the steering assembly of the vehicle periodically for loose nuts and bolts. If loose nuts and bolts are found, see your Polaris dealer for service before operating the vehicle.

Rear Spring

The rear shock absorber spring is adjusted by rotating the adjuster either clockwise or counterclockwise to increase or decrease spring tension.

Accessory springs are available through your Polaris dealer.

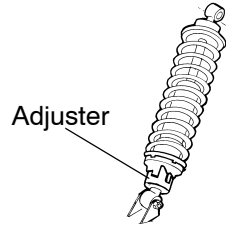

Side Panel Removal

1. Remove the seat.
2. Remove the three fasteners securing the side panel to the vehicle.
3. Pull the side panel away from the vehicle.

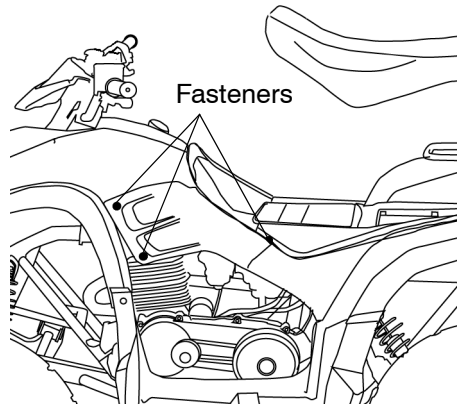

MAINTENANCE

Handlebars

WARNING! Improper adjustment of the handlebars or incorrect torquing of the adjuster block tightening bolts can cause limited steering or loosening of the handlebars, resulting in loss of control and serious injury or death. Follow the adjustment procedures exactly, or see your Polaris dealer for service.

The handlebars can be adjusted for rider preference.

1. Remove the handlebar cover.
2. *Loosen* (do not remove) the four handlebar clamp bolts.
3. Adjust the handlebar to the desired height.
4. Be sure the handlebars do not contact the gas tank or any other part of the machine when turned fully to the left or right.
5. Tighten the front handlebar clamp bolts first, then tighten the rear bolts. Torque to 34 Nm.

Tip: A gap of up to 3 mm should remain at the rear bolts.

Carburetor

Your Polaris vehicle is calibrated at the factory for optimal performance at altitudes ranging from zero to 1800 meters and at temperatures of 4 degrees C. or higher. Above 1800 meters the engine air/fuel mixture becomes too rich and the engine loses approximately 3% of its power for each 300 meter increase in elevation. Although this power cannot be regained, adjustments to the carburetor and drive system can be made to allow more efficient operation. Optional jets and clutch components, available from your Polaris dealer, are required for operation above 1800 meters. Jetting is required only when operating below 4 degrees C. at 1800 meters and lower.

Tip: Continuous operation of the engine without proper jetting when required can cause poor performance, overheating or engine damage. See your Polaris dealer for more information about jetting.

Carburetor/Engine Idle RPM Adjustment

If necessary, the carburetor can be adjusted.

1. Position the vehicle on a level surface. Place the transmission in gear. Lock the parking brake.
2. Start the engine. Allow it to idle for approximately five minutes. Stop the engine.
3. Turn the carburetor idle screw in (clockwise) to raise RPM. Turn the screw out (counterclockwise) to lower RPM.

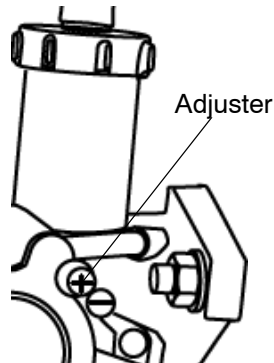

MAINTENANCE

Throttle Cable Freeplay

Adjust throttle cable freeplay at the handlebar.

1. Slide the boots off the inline cable adjuster sleeve. Loosen the adjuster locknut.
2. Turn the adjuster until 1.6-3 mm of freeplay exists at the lever. Move the throttle lever back and forth several times while adjusting.
3. Tighten the lock nut and slide the boots over the cable adjuster until they touch at the midpoint of the adjuster.

Tip: Engine RPM should not increase when steering is turned full left or right. Readjust cable freeplay if this occurs.

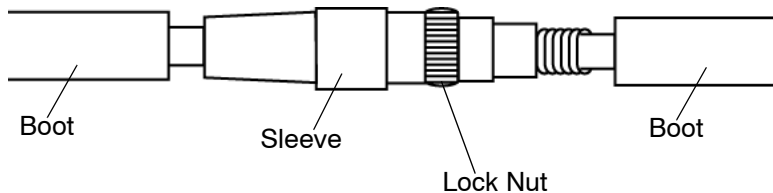
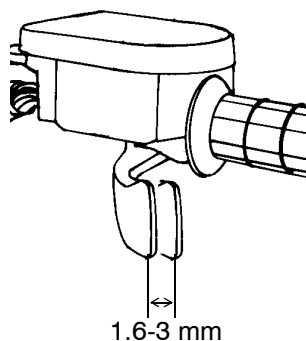

Tires

⚠ WARNING

Operating your ATV with worn tires, improperly inflated tires, non-standard tires or improperly installed tires will affect vehicle handling and could cause an accident resulting in serious injury or death. Always follow all tire maintenance procedures as outlined in this manual and on the labels on the vehicle. Always use original equipment size and type when replacing tires.

Refer to the specifications section beginning on page 86 for recommended tire type, size and pressure.

Wheel and Hub Tightening

Wheel hub and bearing tightness and spindle nut retention are critical items. These services must be performed by an authorized dealer.

Tire Tread Depth

Always replace tires when tread depth is worn to 3 mm or less.

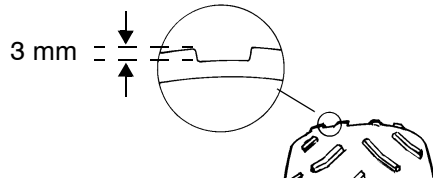

MAINTENANCE

Tires

Wheel Removal

1. Position the vehicle on a level surface. Place the transmission in gear. Lock the parking brake.
2. Loosen the wheel nuts slightly.
3. Safely place jackstands under the vehicle.
4. Remove the wheel nuts. Remove the wheel.



Wheel Installation

1. Place the wheel on the wheel hub.
2. Install the wheel nuts finger tight.
3. Carefully remove the jackstands.
4. Torque the wheel nuts to 37 Nm.

Air Filter

1. Position the vehicle on a level surface. Place the transmission in gear. Lock the parking brake.
2. Remove the seat.
3. Release the air box cover clips. Remove the air box cover.
4. Loosen the hose clamp and remove the filter.
5. Remove the pre-filter from the main filter.
6. Wash the pre-filter in soapy water. Rinse and air dry.
7. Reinstall the pre-filter over the main filter. Replace the main filter if needed.
8. Reverse the steps to reinstall all components.

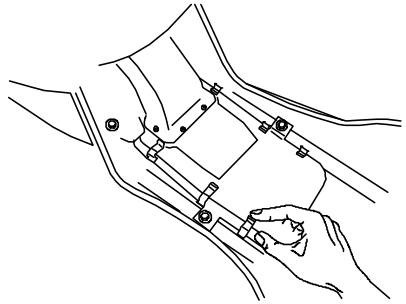

MAINTENANCE

Spark Plugs

Spark Plug Recommendations

Refer to the specifications section beginning on page 86 for the recommended spark plug type and gap for your vehicle.

NOTICE: Using non-recommended spark plugs can result in serious engine damage. Always use Polaris-recommended spark plugs.

Plug Condition	Torque Specification
New Spark Plug	12-15 Nm
Previously Installed Spark Plug	23-27 Nm

Spark Plug Inspection

Check the spark plug firing end condition after the engine has been warmed up and the vehicle has been driven at higher speeds. Immediately check the spark plug for correct color. See page 69.



A hot exhaust system and engine can cause burns. Wear protective gloves when removing a spark plug for inspection.

1. Remove the spark plug cap.
2. Using the special wrench provided in the tool pouch, rotate the spark plug counterclockwise to remove it.
3. Inspect the electrodes for wear and carbon buildup. Replace worn or fouled plugs. Verify that the gap is at specification before installation.
4. Reverse the procedure for spark plug installation. Torque to specification.

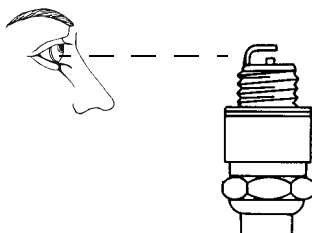
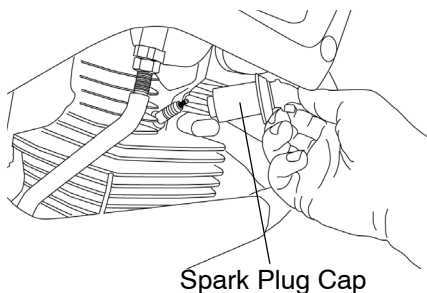

Spark Plugs

Spark Plug Condition

Normal Spark Plug

The normal insulator tip is gray, tan or light brown. There will be few combustion deposits. The electrodes are not burned or eroded. This indicates the proper type and heat range for the engine and the service.

The tip should not be flaky and white. A white insulator tip indicates overheating, caused by use of an improper spark plug or incorrect carburetion adjustments.

Wet Fouled Spark Plug

The wet fouled insulator tip is black. A damp oil film covers the firing end. There may be a carbon layer over the entire nose. Generally, the electrodes are not worn. General causes of fouling are excessive oil, use of non-recommended oil, improper use of the choke, or incorrect throttle body/carburetor adjustments.

MAINTENANCE

Lights

Poor lighting can result in reduced visibility when driving. Headlight and taillight lenses become dirty during normal operation. Clean lights frequently and replace burned out lamps promptly. Always make sure lights are adjusted properly for best visibility.

Headlamp Replacement

To access the assembly from the front, remove the front cover and unplug the wiring harness. Remove the headlight assembly from the vehicle.

To access the headlight assembly without removing the front cover, reach up under the front cab.

1. Remove the rubber cover from the back of the headlight.
2. Rotate the socket counter-clockwise and pull it away from the headlight assembly.
3. Remove the headlamp and install the new headlamp.
4. Reinstall all components.

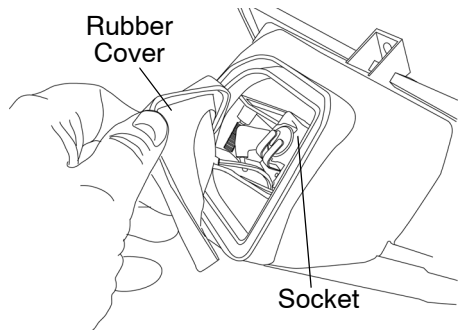

Taillight/Brake Light Lamp Replacement

1. Remove the taillight lens cover mounting screws.
2. Remove the lens cover.
3. Remove the lamp.
4. Apply dielectric grease to the socket and install a new lamp.
5. Test the light for proper operation.
6. Reinstall the lens cover.

Vehicle Immersion

If the vehicle stops while fully submerged, major engine damage can result if the machine is not thoroughly inspected. Take the vehicle to your dealer before starting the engine.

If it's impossible to take your vehicle to a dealer before starting it, follow the steps outlined below.

1. Move the vehicle out of the water.
2. Turn the fuel valve off.
3. Check the air box and dry any water.
4. Remove the spark plug.
5. Drain any water found in the air box.
6. Loosen the carburetor drain screw and drain the carburetor.
7. Turn the engine over several times using the electric start.
8. Dry the spark plug. Reinstall the plug or install a new plug.
9. Tighten the carburetor drain screw.
10. Turn the fuel valve on.
11. Attempt to start the engine. If necessary, repeat the drying procedure.
12. Have the vehicle serviced by your dealer promptly, whether you succeed in starting it or not.
13. If water has been ingested into the transmission, follow the procedure on page 72 for drying.

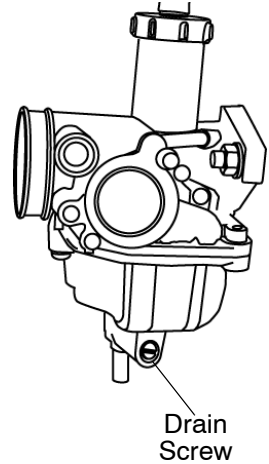

MAINTENANCE

Constant Variable Transmission (CVT) System

WARNING

Do not modify any component of the CVT system. Doing so may reduce its strength so that a failure may occur at a high speed. The CVT system has been precision balanced. Any modification will cause the system to be out of balance, creating vibration and additional loads on components.

The CVT system rotates at high speeds, creating large amounts of force on clutch components. Extensive engineering and testing has been conducted to ensure the safety of this product. However, as the owner, you have the following responsibilities to make sure this system remains safe:

- Always follow all recommended maintenance procedures. See your dealer as outlined in the owner's manual.
- This CVT system is intended for use on Polaris products only. Do not install it in any other product.
- Always make sure the CVT housing is securely in place during operation.

CVT Drying

If water is ingested into the CVT system, dry it before operating the vehicle.

1. Position the vehicle on a level surface.
2. Place the transmission in neutral.
3. Lock the parking brake.
4. Remove the CVT drain plug from the bottom of the CVT cover. Drain the water. Reinstall the drain plug. Torque to 24 Nm.
5. Start the engine. Place the transmission in neutral.
6. Apply varying throttle for 10-15 seconds to expel the moisture and air-dry the belt and clutches. *Do not hold the throttle wide open.*
7. Allow the engine RPM to settle to idle speed, then shift the transmission into forward gear.
8. Test for belt slippage. If the belt slips, repeat the process.
9. Take the vehicle to your dealer for service promptly.

Battery

⚠ WARNING

Improperly connecting or disconnecting battery cables can result in an explosion and cause serious injury or death. When removing the battery, always disconnect the negative (black) cable first. When reinstalling the battery, always connect the negative (black) cable last.

⚠ WARNING

Battery electrolyte is poisonous. It contains sulfuric acid. Serious burns can result from contact with skin, eyes or clothing.

Antidote:

External: Flush with water.

Internal: Drink large quantities of water or milk. Follow with milk of magnesia, beaten egg, or vegetable oil. Call physician immediately.

Eyes: Flush with water for 15 minutes and get prompt medical attention.

Batteries produce explosive gases. Keep sparks, flame, cigarettes, etc. away. Ventilate when charging or using in an enclosed space. Always shield eyes when working near batteries. **KEEP OUT OF REACH OF CHILDREN.**

MAINTENANCE

Battery

Battery Removal

1. Remove the seat.
2. Disconnect the battery hold-down strap.
3. Disconnect the black (negative) battery cable first.
4. Disconnect the red (positive) battery cable last.
5. Lift the battery out of the battery compartment.



Battery Installation

1. Ensure that the battery is fully charged.
2. Place the battery in the battery holder.
3. Connect and tighten the red (positive) cable first.
4. Connect and tighten the black (negative) cable last.
5. Attach the hold-down strap
6. Verify that cables are properly routed. Cables should be safely tucked away at the front and rear of the battery.
7. Reinstall the seat.

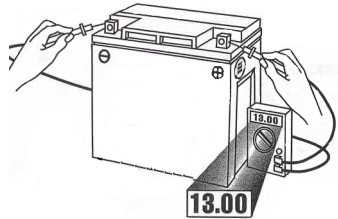

Battery

Battery Charging

The following battery charging instructions apply only to the installation of an activated, sealed battery. Read all instructions before proceeding with the installation of this battery.

A sealed battery is already filled with electrolyte. It has been sealed and is fully charged at the factory. Always keep a sealed battery fully charged.

- DO NOT pry the sealing strip off.
 - DO NOT add any other fluid to this battery.
 - A fully charged battery will register 12.8 V or higher.
1. Check battery voltage with a voltmeter or multimeter.
 2. If voltage is low, recharge the battery at 1.2 amps or less until the voltage is 12.8 or greater.

Tip: When using an automatic charger, refer to the charger manufacturer's instructions for recharging. When using a constant current charger, follow the guidelines below.

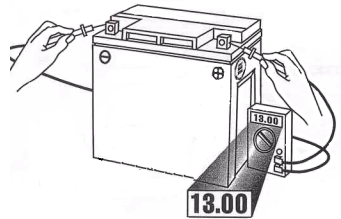

Always verify battery condition before and 1-2 hours after the end of charging.

State of Charge	Voltage	Action	Charge Time (Using constant current charger @ standard amps specified on top of battery)
100%	12.8-13.0 volts	None, check at 3 mos. from date of manufacture	None required
75%-100%	12.5-12.8 volts	May need slight charge, if no charge given, check in 3 months	3-6 hours
50%-75%	12.0-12.5 volts	Needs charge	5-11 hours
25%-50%	11.5-12.0 volts	Needs charge	At least 13 hours, verify state of charge
0%-25%	11.5 volts or less	Needs charge with desulfating charger	At least 20 hours

MAINTENANCE

Battery

Battery Storage

Whenever the vehicle is not used for a period of three months or more, remove the battery from the vehicle, ensure that it's fully charged, and store it out of the sun in a cool, dry place. Check battery voltage each month during storage and recharge as needed to maintain a full charge.

Polaris recommends maintaining battery charge by using a Polaris Battery Tender charger or by charging about once a month to make up for normal self-discharge. Battery Tender can be left connected during the storage period, and will automatically charge the battery if the voltage drops below a pre-determined point. See page 82 for the part numbers of Polaris products.

Cleaning and Storage

Washing the Vehicle

Keeping the vehicle clean will extend the life of components.

NOTICE: High water pressure may damage components. Polaris recommends washing the vehicle by hand or with a garden hose, using mild soap.

Certain products, including insect repellents and chemicals, will damage plastic surfaces. Do not allow these types of products to contact the vehicle.

The best and safest way to clean your Polaris vehicle is with a garden hose and a pail of mild soap and water.

1. Use a professional-type washing cloth, cleaning the upper body first and the lower parts last.
2. Rinse with clean water frequently.
3. Dry surfaces with a chamois to prevent water spots.

Washing Tips

- Avoid the use of harsh cleaners, which can scratch the finish.
- Do not use a power washer to clean the vehicle.
- Do not use medium to heavy duty compounds on the finish.
- Always use clean cloths and pads for cleaning and polishing. Old or reused cloths and pads may contain dirt particles that will scratch the finish.

MAINTENANCE

Cleaning and Storage

Washing the Vehicle

If a high pressure water system is used for cleaning (not recommended), exercise extreme caution. The water may damage components. Avoid directing the water stream at the following items:

- Wheel bearings
- Transmission seals
- Brakes
- Cab and body panels
- Labels and decals
- Electrical components
- Switches and controls

If an informational or graphic label becomes illegible or comes off, contact your Polaris dealer to purchase a replacement. Replacement *safety* labels are provided by Polaris at no charge.

Grease all zerk fittings immediately after washing. Allow the engine to run for a while to evaporate any water that may have entered the engine or exhaust system.

Polishing the Vehicle

Polaris recommends the use of common household aerosol furniture polish for polishing the finish on your Polaris vehicle. Follow the instructions on the container.

Polishing Tips

- Avoid the use of automotive products, some of which can scratch the finish of your vehicle.
- Always use clean cloths and pads for cleaning and polishing. Old or reused cloths and pads may contain dirt particles that will scratch the finish.

Cleaning and Storage

Storage Tips

NOTICE: Starting the engine during the storage period will disturb the protective film created by fogging and damage could occur. Never start the engine during the storage period.

Clean the Exterior

Make any necessary repairs and clean the vehicle as recommended. See page 77.

Stabilize the Fuel

1. Fill the fuel tank.
2. Add Polaris Carbon Clean Fuel Treatment or Polaris Fuel Stabilizer. Follow the instructions on the container for the recommended amount. Carbon Clean removes water from fuel systems, stabilizes fuel and removes carbon deposits from pistons, rings, valves and exhaust systems.
3. Allow the engine to run for 15-20 minutes to allow the stabilizer to disperse through the fuel in the tank and carburetor.
4. Stop the engine.
5. Turn the fuel valve off.
6. Drain the carburetor bowl.

Oil and Filter

Change the oil and filter. See page 53.

Air Filter / Air Box

1. Inspect and clean (or replace) the pre-cleaner and air filter.
2. Clean the air box.
3. Drain the sediment tube.

MAINTENANCE

Cleaning and Storage

Storage Tips

Fluid Levels

Inspect the fluid levels. Change fluids as recommended in the Periodic Maintenance Chart beginning on page 48.

- Rear gearcase
- Transmission
- Brake fluid

Fog the Engine

Use Polaris Engine Fogging Oil. Follow label directions carefully.

Inspect and Lubricate

Inspect all cables and lubricate all areas of the vehicle as recommended in the Periodic Maintenance Chart beginning on page 48.

Battery Storage

See page 75-76 for storage and charging procedures.

Storage Area/Covers

1. Make sure tire pressure is at specification.
2. Using suitable supports under the frame, raise the vehicle slightly so that the tires are not touching the ground.
3. Be sure the storage area is well ventilated.
4. Cover the machine with an appropriate cover. Do not use plastic or coated materials, as they do not allow proper ventilation to prevent condensation, corrosion and oxidation.

MAINTENANCE

Transporting the Vehicle

Follow these procedures when transporting the vehicle.

1. Stop the engine.
2. Place the transmission in gear.
3. Lock the parking brake.
4. Turn the fuel valve off.
5. Secure the fuel cap, oil cap and seat.
6. Remove the key to prevent loss during transporting.
7. Always tie the frame of the vehicle to the transporting unit securely with suitable straps or rope. Do not attach tie straps to the front bumper, racks or handlebars.

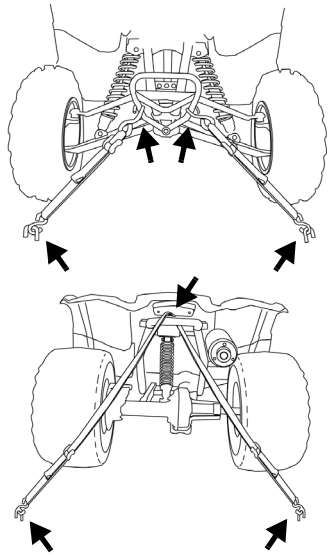

POLARIS PRODUCTS

Part Number	Description
Engine Lubricant	
2870791	Fogging Oil (355 ml Aerosol)
2876244	PS-4 PLUS Performance Synthetic 2W-50 4-Cycle Oil (.95 l)
2876245	PS-4 PLUS Performance Synthetic 2W-50 4-Cycle Oil (3.8 l)
Gearcase / Transmission Lubricants	
2873602	Premium AGL Synthetic Gearcase Lubricant (.95 l)
2873603	Premium AGL Synthetic Gearcase Lube (3.8 l)
2870465	Pump for 3.8 Liter Jug
2871653	Premium ATV Angle Drive Fluid (237 ml)
2872276	Premium ATV Angle Drive Fluid (9.5 l)
Grease / Specialized Lubricants	
2871312	Grease Gun Kit, Premium All Season
2871322	Premium All Season Grease (89 ml cartridge)
2871423	Premium All Season Grease (414 ml cartridge)
2871460	Starter Drive Grease
2871515	Premium U-Joint Lube (89 ml)
2871551	Premium U-Joint Lube (414 ml)
2871329	Dielectric Grease (Nyogel™)
Additives / Miscellaneous	
2871326	Carbon Clean Plus (355 ml)
2870652	Fuel Stabilizer (473 ml)
2872189	DOT4 Brake Fluid
2871956	Loctite™ 565 Thread Sealant
2859044	Polaris Battery Tender™ Charger

TROUBLESHOOTING

Engine Doesn't Turn Over

Possible Cause	Solution
Tripped circuit breaker	Reset the breaker
Low battery voltage	Recharge the battery to 12.8 VDC
Loose battery connections	Check all connections and tighten
Loose solenoid connections	Check all connections and tighten

Engine Turns Over, Fails to Start

Possible Cause	Solution
Out of fuel	Turn fuel valve to reserve, refuel
Clogged fuel valve or filter	Inspect and clean or replace
Water is present in fuel	Drain the fuel system and refuel
Fuel valve is turned off	Turn the fuel valve on
Old or non-recommended fuel	Replace with fresh recommended fuel
Fouled or defective spark plug(s)	Inspect plugs and replace if necessary
No spark to spark plug	Inspect plugs, verify stop switch is on
Overuse of choke	Inspect, clean and/or replace spark plugs
Water or fuel in crankcase	Immediately see your Polaris dealer
Low battery voltage	Recharge the battery to 12.8 VDC
Mechanical failure	See your dealer

Engine Backfires

Possible Cause	Solution
Weak spark from spark plug	Inspect, clean and/or replace spark plugs
Incorrect spark plug gap or heat range	Set gap to specs or replace plugs
Old or non-recommended fuel	Replace with fresh recommended fuel
Incorrectly installed spark plug wires	See your dealer
Incorrect ignition timing	See your dealer
Mechanical failure	See your dealer

TROUBLESHOOTING

Engine Pings or Knocks

Possible Cause	Solution
Poor quality or low octane fuel	Replace with recommended fuel
Incorrect ignition timing	See your dealer
Incorrect spark plug gap or heat range	Set gap to specs or replace plugs
Idle set too low	Adjust idle speed

Engine Runs Irregularly, Stalls or Misfires

Possible Cause	Solution
Fouled or defective spark plug(s)	Inspect, clean and/or replace spark plugs
Worn or defective spark plug wires	See your dealer
Incorrect spark plug gap or heat range	Set gap to specs or replace plugs
Loose ignition connections	Check all connections and tighten
Water present in fuel	Replace with new fuel
Low battery voltage	Recharge battery to 12.8 VDC
Kinked or plugged fuel tank vent line	Inspect and replace
Incorrect fuel	Replace with recommended fuel
Clogged air filter	Inspect and clean or replace
Reverse speed limiter malfunction	See your dealer
Electronic throttle control malfunction	See your dealer
Other mechanical failure	See your dealer
Possible Lean Fuel Cause	Solution
Low or contaminated fuel	Add or change fuel, clean the fuel system
Low octane fuel	Replace with recommended fuel
Clogged fuel filter	Replace filter
Incorrect jetting	See your dealer
Possible Rich Fuel Cause	Solution
Overuse of choke	Inspect, clean and/or replace spark plugs
Fuel is very high octane	Replace with lower octane fuel
Incorrect jetting	See your dealer

TROUBLESHOOTING

Engine Stops or Loses Power

Possible Cause	Solution
Out of fuel	Turn fuel valve to reserve, refuel
Kinked or plugged fuel vent line	Inspect and replace
Water is present in fuel	Replace with new fuel
Overuse of choke	Inspect, clean and/or replace spark plugs
Fouled or defective spark plug(s)	Inspect, clean and/or replace spark plugs
Worn or defective spark plug wires	See your dealer
Incorrect spark plug gap or heat range	Set gap to specs or replace plug
Loose ignition connections	Check all connections and tighten
Low battery voltage	Recharge the battery to 12.8 VDC
Incorrect fuel	Replace with fresh recommended fuel
Clogged air filter	Inspect and clean or replace
Reverse speed limiter malfunction	See your dealer
Electronic throttle control malfunction	See your dealer
Other mechanical failure	See your dealer
Overheated engine	Clean engine exterior; see your Polaris dealer

SPECIFICATIONS

Phoenix 200 Quadricycle	
Maximum Weight Capacity	129 kg
Dry Weight	179 kg
Fuel Capacity	9.5 liters
Engine Oil Capacity	1200 ml
Transmission Oil	550 ml
Rear Gearcase Oil	120 m
Rear Rack Capacity	31.7 kg
Hitch Tongue Weight Capacity	13.6 kg (rear rack weight and tongue weight not to exceed 13.6 kg)
Hitch Towing Weight Capacity	136 kg
Overall Length	165 cm
Overall Width	106.7 cm
Overall Height	106.7 cm
Seat Height	81.3 cm
Wheelbase	114.3 cm
Ground Clearance	14.5 cm
Minimum Turning Radius	165 cm unloaded
Engine Type	4-Cycle, Single Cylinder
Lubrication	Wet sump
Engine Cooling	Air
Displacement	196 cc
Bore x Stroke	65 x 59
Alternator Output	210w @5000 rpm
Compression Ratio	9.2:1 Full Stroke
Carburetor	1 / 22 mm (VM Type)
Pilot Jet	38
Main Jet	100
Air Screw	1 Turn Out
Jet Needle	2MKNN-4 clip
Ignition System	DC CDI
Ignition Timing	32° +/- 2° @ 3000 RPM
Spark Plug / Gap	NGK CR7HSA / 0.6-0.7 mm
Driving System Type	Constant Variable Transmission (CVT)
Shift Type	Side Lever (F/N/R)

SPECIFICATIONS

Phoenix 200 Quadricycle

Drive Ratio, Front	N/A
Tires, Front	21x7-10 / 27.6 kPa
Tires, Rear	20x10-9 / 27.6 kPa
Front Suspension	Dual A-Arm w/17.8 cm travel
Rear Suspension	Mono-Shock Swing Arm w/16.5 cm travel
Shock Adjustment	CAM
Brakes, Rear (Handlebar)	Mechanical Drum
Brake, Foot	Hydraulic, All Wheel
Brake, Parking	Mechanical, Rear
Headlight	Front Cover, Hi/Lo 35W Halogen
Taillight	12V 5W
Brake Light	12V 21W
Battery	12V 12 AH
Electric Start	Standard
Speedometer	Standard
Neutral Indicator	Standard
Reverse Indicator	Standard
Tool Kit	Standard
DC Plug-In (rear)	Accessory
Windshield	Accessory

Jetting Chart

ALTITUDE (Meters)	AMBIENT TEMPERATURE	
	Below 5° C	5°C and above
0-1800	102	100
1800-3700	96	92

Clutching Chart

Altitude (Meters)	Roller Weight Grams Each
0-1800	6 @ 14.7 grams
1800-3700	6 @ 9.5 grams

WARRANTY

LIMITED WARRANTY

Polaris Industries Inc., 2100 Highway 55, Medina, MN 55340, gives a TWO YEAR LIMITED WARRANTY on all components of the Polaris Quadricycle against defects in material or workmanship. This warranty covers the parts and labor charges for repair or replacement of defective parts which are covered by this warranty. This warranty begins on the date of purchase. This warranty is transferable to another consumer during the warranty period through a Polaris dealer.

REGISTRATION

At the time of sale, the Warranty Registration Form must be completed by your dealer and submitted to Polaris within ten days. Upon receipt of this registration, Polaris will record the registration for warranty. **THE PURCHASER MUST COMPLETE A QUADRICYCLE SAFETY TRAINING COURSE PROVIDED BY THE DEALER IN ORDER TO HAVE VALID WARRANTY ON THE QUADRICYCLE.** No verification of registration will be sent to the purchaser as the copy of the Warranty Registration Form will be the warranty entitlement. If you have not signed the original registration and received the "customer copy", please contact your dealer immediately. **NO WARRANTY COVERAGE WILL BE ALLOWED UNLESS YOUR QUADRICYCLE IS REGISTERED WITH POLARIS.**

Initial dealer preparation and set-up of your vehicle is very important in ensuring trouble-free operation. Purchasing a machine in the crate or without proper dealer set-up will void your warranty coverage.

LIMITATIONS OF WARRANTIES AND REMEDIES

The Polaris limited warranty excludes any failures that are not caused by a defect in material or workmanship. This warranty does not cover accidental damage, normal wear and tear, abuse or improper handling. This warranty also does not cover any Quadricycle that has been altered structurally, modified, neglected, improperly maintained, used for racing, or used for purposes other than for which it was manufactured, or for any damages which occur during trailer transit or as a result of unauthorized service or the use of unauthorized parts. In addition, this warranty does not cover physical damage to paint or finish, stress cracks, tearing or puncturing of upholstery material, corrosion, or defects in parts, components or the vehicle due to fire, explosions or any other cause beyond Polaris' control.

This warranty does not cover the use of unauthorized lubricants, chemicals, or fuels that are not compatible with the Quadricycle. The exclusive remedy for breach of this warranty shall be, at Polaris' exclusive option, repair or replacement of any defective materials, or components or products. **THE REMEDIES SET FORTH IN THIS WARRANTY ARE THE ONLY REMEDIES AVAILABLE TO ANY PERSON FOR BREACH OF THIS WARRANTY. POLARIS SHALL HAVE NO LIABILITY TO ANY PERSON FOR INCIDENTAL, CONSEQUENTIAL OR SPECIAL DAMAGES OF ANY DESCRIPTION, WHETHER ARISING OUT OF EXPRESS OR IMPLIED WARRANTY OR ANY OTHER CONTRACT, NEGLIGENCE, OR OTHER TORT OR OTHERWISE.** Some states do not permit the exclusion or limitation of incidental or consequential damages or implied warranties, so the above limitations or exclusions may not apply to you if inconsistent with controlling state law.

WARRANTY

LIMITATIONS OF WARRANTIES AND REMEDIES

ALL IMPLIED WARRANTIES (INCLUDING BUT NOT LIMITED TO THE IMPLIED WARRANTIES OF MERCHANTABILITY AND FITNESS FOR A PARTICULAR PURPOSE) ARE LIMITED IN DURATION TO THE ABOVE TWO YEAR WARRANTY PERIOD. POLARIS FURTHER DISCLAIMS ALL EXPRESS WARRANTIES NOT STATED IN THIS WARRANTY. Some states do not allow limitations on how long an implied warranty lasts, so the above limitation may not apply to you if inconsistent with controlling state law.

HOW TO OBTAIN WARRANTY SERVICE

If your Quadricycle requires warranty service, you must take it to a Polaris dealer authorized to repair Polaris Quadricycles. When requesting warranty service you must present your copy of the Warranty Registration form to the dealer. (THE COST OF TRANSPORTATION TO AND FROM THE DEALER IS YOUR RESPONSIBILITY). Polaris suggests that you use your original selling dealer; however, you may use any Polaris Servicing Dealer to perform warranty service.

Please work with your dealer to resolve any warranty issues. Should your dealer require any additional assistance they will contact the appropriate personnel at Polaris.

This warranty gives you specific legal rights, and you may also have other rights which vary from state to state.

If any of the above terms are void because of state or federal law, all other warranty terms will remain in effect.

INDEX

A

Air Filter 67

B

Battery 73-76

 Charging 75

 Installation 74

 Removal 74

 Storage 76

Boots 9

Brake

 All-Wheel Brake 25

 Foot Brake 25

 Parking Brake 25

 Rear Brake Lever 24

Brake Check 58

Brake Fluid 57

Brake Fluid (Foot Brake) 58

Brake Freeplay 59

Brake Lever Travel 59

Brake Light 70

Brake Maintenance 57-59

Break-In Period 29

C

Carburetor 63

Carburetor Adjustment 63

Cargo 44-45

Choke Lever 23

Cleaning and Storage 77-80

Clothing 9

Clutching Chart 87

Cold Weather Operation 33

Constant Variable Transmission 72

CVT Drying 72

CVT System 72

D

Drivetrain Break-In 29

Driving Downhill 39

Driving in Reverse 43

Driving on a Sidehill 38

Driving on Slippery Surfaces 36

Driving Over Obstacles 42

D

Driving Procedures 34

Driving Properly 34

Driving Through Water 41

Driving Uphill 37

E

Engine Break-In 29

Engine Fogging 80

Engine Idle RPM Adjustment 63

Engine Oil 52

Equipment Modifications 7

Exhaust Emission Control System .. 47

Eye Protection 9

F

Fuel Safety 11

Fuel Tank Cap 27

Fuel Valve 27

G

Gasoline Handling 11

Gear Selector 28

Gearcase Oil 56

Gloves 9

H

Handlebar Adjustment 62

Hauling Cargo 44-45

Hazard Warning Switch 23

Headlamp Replacement 70

Helmet 8

Horn Switch 23

I

Idle RPM Adjustment 63

Immersion 71

Indicator Lights 26

J

Jetting Chart 87

K

Key Switch 22

Kick-Start Lever 28

K-Turn 40

L

Levers	22-24
Light Switch	23
Lights	
Headlamp Replacement	70
Indicator Lights	26
Taillight/Brake Light	70
Load Distribution	45
Lubrication Guide	51

M

Maintenance Chart	48-50
Maintenance Chart Key	48
Mirrors	26
Modifications	7

N

Noise Emission Control System	47
-------------------------------------	----

O

Oil	
Engine	52
Rear Gearcase	56
Transmission	55
Oil and Filter Change	53-54
Oil Level, Engine	52
Oil Level, Rising	33
Oil Recommendations	
Engine	52
Rear Gearcase	56
Transmission	55
Oil Specifications, Engine	52
Operator Safety	10-17

P

Panel Removal	61
Parking Brake	25
Parking on an Incline	46
Periodic Maintenance Chart	48-50
Polaris Product List	82
Polishing the Vehicle	78
Pre-Ride Checklist	31

R

Reverse Operation	43
Riding Gear	8, 9

S

Safe Operation Practices	30
Safety Labels	18-21
Age Warning	19
Clutch Cover Warning	19
Discretionary Warning	20
General Warning	19
Hitch Warning	20
No Passenger Warning	21
Rack Warning	20
Tire Pressure/Load Warning	21
Safety Training	7
Severe Use	48
Shifter	28
Side Panel Removal	61
Sidehilling	38
Signal Words	4
Spark Plugs	68-69
Spring Adjustments, Rear	61
Start Switch	22
Starting the Engine	32-33
Starting, Kick-Start Lever	28
Steering Assembly	61
Storage	77-80
Switches	22-24
Hazard Warning Switch	23
Horn Switch	23
Light Switch	23
Main Key Switch	22
Start Switch	22
Turn Signal Switch	23

T

Taillight	70
Throttle Cable Freeplay	64
Throttle Lever	24
Tires	65-66
Tread Depth	65
Wheel and Hub Tightening	65
Wheel Installation	66
Wheel Removal	66
Toe Alignment	60
Towing	45
Training	7
Transmission Oil	55
Transmission System (CVT)	72

INDEX

T

Transporting the Vehicle	81
Turn Signal Switch	23
Turning Around on a Hill	40
Turning the Vehicle	35

V

Vehicle Identification Numbers	6
Vehicle Immersion	71

W

Warning Symbols	4
Washing the Vehicle	77-78
Wheel and Hub Tightening	65
Wheel Installation	66
Wheel Removal	66

Free Manuals Download Website

<http://myh66.com>

<http://usermanuals.us>

<http://www.somanuals.com>

<http://www.4manuals.cc>

<http://www.manual-lib.com>

<http://www.404manual.com>

<http://www.luxmanual.com>

<http://aubethermostatmanual.com>

Golf course search by state

<http://golfingnear.com>

Email search by domain

<http://emailbydomain.com>

Auto manuals search

<http://auto.somanuals.com>

TV manuals search

<http://tv.somanuals.com>