

OWNER'S MANUAL SUPPLEMENT
2001 PRO X 440
PN 9916166



IMPORTANT: This is a supplement to your owner's manual. This information should remain with your owner's manual at all times.

Capacities and Dimensions	
Body Style	Edge
Rider Capacity	1
Coolant Capacity (qts)	4
Chaincase Oil Capacity (oz.)	9
Dry Weight (Est.)	485
Fuel Tank capacity (Gallons)	11.8
Height (in.)	44
Length (in.)	111
Oil Capacity (Quarts)	2.0
Ski Center Distance (in.)	42.5
Width (in.)	48
Brake Type	Hydraulic Disc 5/8 Piston
Drive Clutch Center Distance	11.5
Clutch Type	P-85
Track Length	121
Track Width	15
Drive Chain Length	74
Reverse Transmission	NA
Sprocket Ratio	22:43
Suspension	
Front Type	Edge Pro-X
IFS Shock Type	Alum IFP / res
Rear Type	Edge Pro-X
Front Torque Arm Limiter	STD
Rear Torque Arm Limiter	Optional
Front Track Shock	Arvin IFP/Res
Rear Track Shock	Arvin IFP/Res

Engine and Cooling	
Engine Model Number	S44-44-PO-4C 2093
Alternator Output	12V 280 W
Bore x Stroke (mm)	66 x 64
Displacement	438
Carburetor/Throttle Body	2 Mikuni
Carburetor Model	TMX34
Main Jet	350
Pilot Jet	22.5
Jet Needle	6GL64-61-3
Needle Jet	Q-8
Cutaway	2.5
Air Screw	1.00
Idle RPM +/-200	1600
Cooling	Liquid
Cylinders	2
Ignition Timing	22° @ 4500 ±1.5 with pipe temper- ature sensor un- plugged
Ignition Type	Digital CDI
Oil Injection	Yes
Spark Plug	RN57YCC Champ
Features	
Electric Fuel Gauge	NA
Electric Start	Not Available
Low Oil Light	Standard
Parking Brake	NA
Speedometer	Standard (not installed)
Tachometer	Standard
Wear Strips	Coolers
Hood Color	Indy Red

Carburetor Jetting

Clutching Chart

	AMBIENT TEMPERATURE	Below -20°F Below -29°C	-20°F to +10° -29°C to -12°C	+10°F - +40°F -12°C - +5°C	Above +40°F Above +5°C	Altitude Meters (Feet)	Shift Weight	Drive Clutch Spring	Driven Clutch Spring	Driven Helix	Chain-case Gearing
Altitude Meters (Feet)	0-900 (0-3000)	390	370	340	320	0-900 0-3000	S53H	Almond Red	#2 Blue / Orange	R49	22:43 74P
	900-1800 (3000-6000)	350	330	310	290	900-1800 (3000-6000)	S51H	Almond Red	#3 Blue / Orange	R49	22:43 74P
	1800-2700 (6000-9000)	320	300	280	260	1800-2700 (6000-9000)	S49H	Almond Red	#3 Blue / Orange	R49	22:43 74P
	2700-3700 (9000-12000)	280	270	250	230	2700-3700 (9000-12000)	S49H	Almond Red	#3 Blue / Orange	R49	22:43 74P

#3 jet needle position for all

Production = 350 main jet for 0°F at 0-1000 feet with 92 octane non-ethanol fuel, the key switch in the 92 octane position, and the timing curve position “D”.

⚠ CAUTION

This engine is jetted for operation at 0 degrees and warmer. Re-jetting is required for temperatures colder than 0° F.

TIMING INFORMATION

The PRO X 440 has been equipped with two switches that will change the timing curve.

The first switch is an ignition switch located on the console. This switch is used to match the timing curve to the type of fuel you are using. The fuel types are 92 octane non-ethanol premium fuel and 110 octane fuel. Do not run the machine in the wrong ignition key position or engine damage will occur.

⚠ CAUTION

Mis-use of the timing selector switch can cause serious engine damage.

Running the machine in the wrong ignition key position will cause engine damage.

Ignition Switch Positions

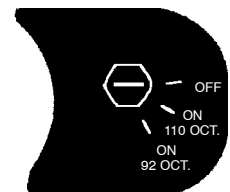

The second switch is located on the airbox and has seven optional curves. These seven options are used to match the fuel type and the racing conditions which may vary, depending on the race. The standard position is “D” and should not be moved unless you are a knowledgeable engine tuner.

Position	Timing Effect
A	+3
B	+2
C	+1
D (Standard Position)	0
E	-2
F	-3
G	-4

The exhaust system has a temperature sensor in the body of the pipe that effects the timing curve as the temperature changes. This feature helps the pipe tune quickly and is not adjustable.

2001 PRO X 440 / XCF SP SPEEDOMETER KIT INSTALLATION INSTRUCTIONS

- Remove plenum.
- Drill 4.5" hole in instrument housing 5.9" from the tachometer center to the center of the new hole.

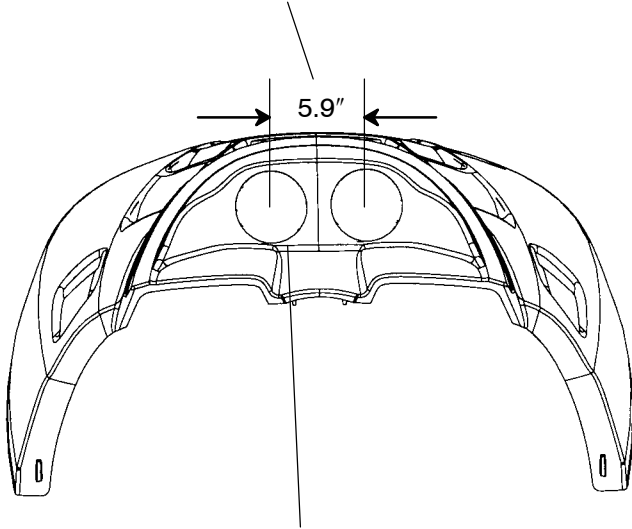

- Relocate tachometer to right side.
- Install speedometer into left hole, placing the cushion between the speedometer and the hood.

Route through hole in plenum

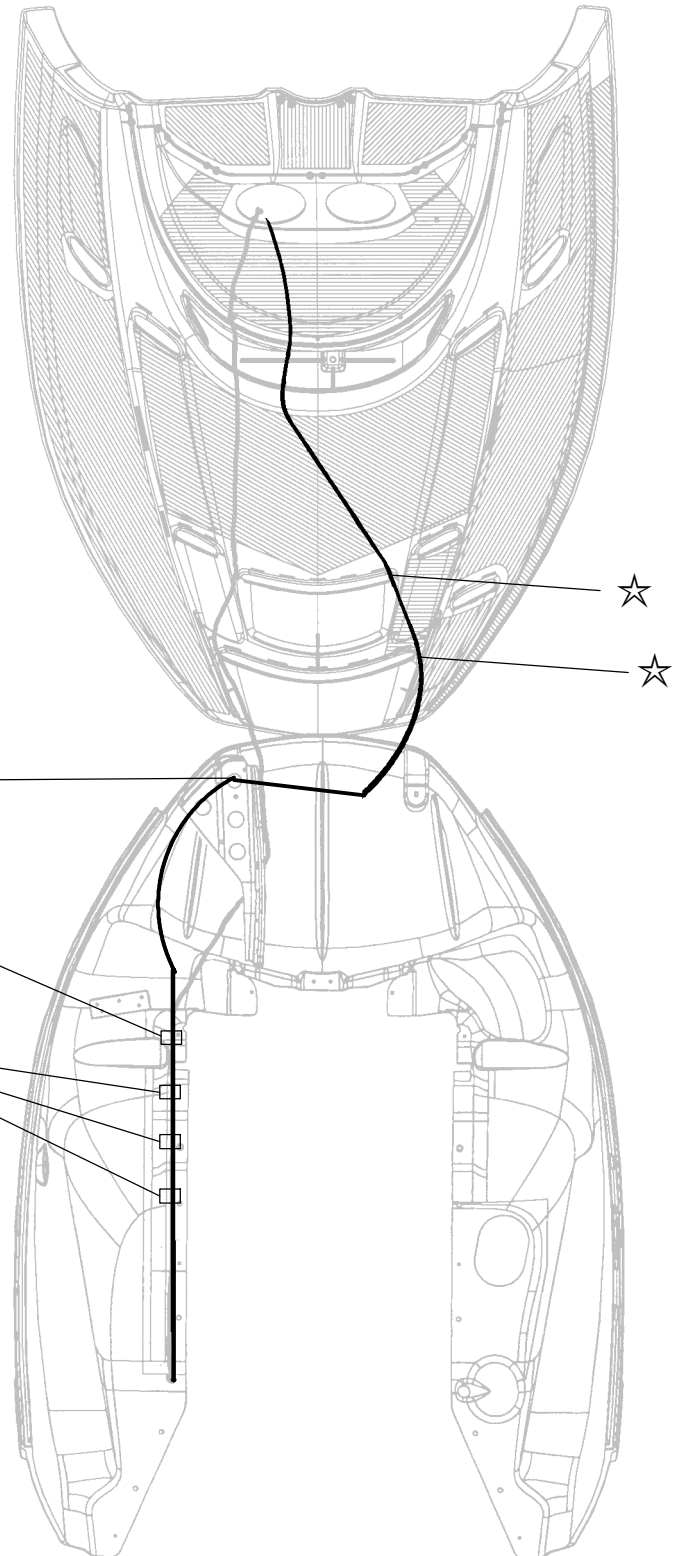

Route Cable through left hinge hole at this point.

Install "J" retainer (PN 7080963) using rivet (PN 7621435)

Install three "U" Clips

- Route speedometer cable through plenum
- Route speedometer cable as illustrated. Tighten cable ends.
- Install plenum
- Using cable ties provided (3) secure cable in places illustrated by a ☆.
- Lay speedometer cable in the channel of the nosepan. Attach with three clips as shown. Use the "J" clip and rivet to secure the wire to the nosepan channel where indicated.

Dark line indicates speedometer cable routing.

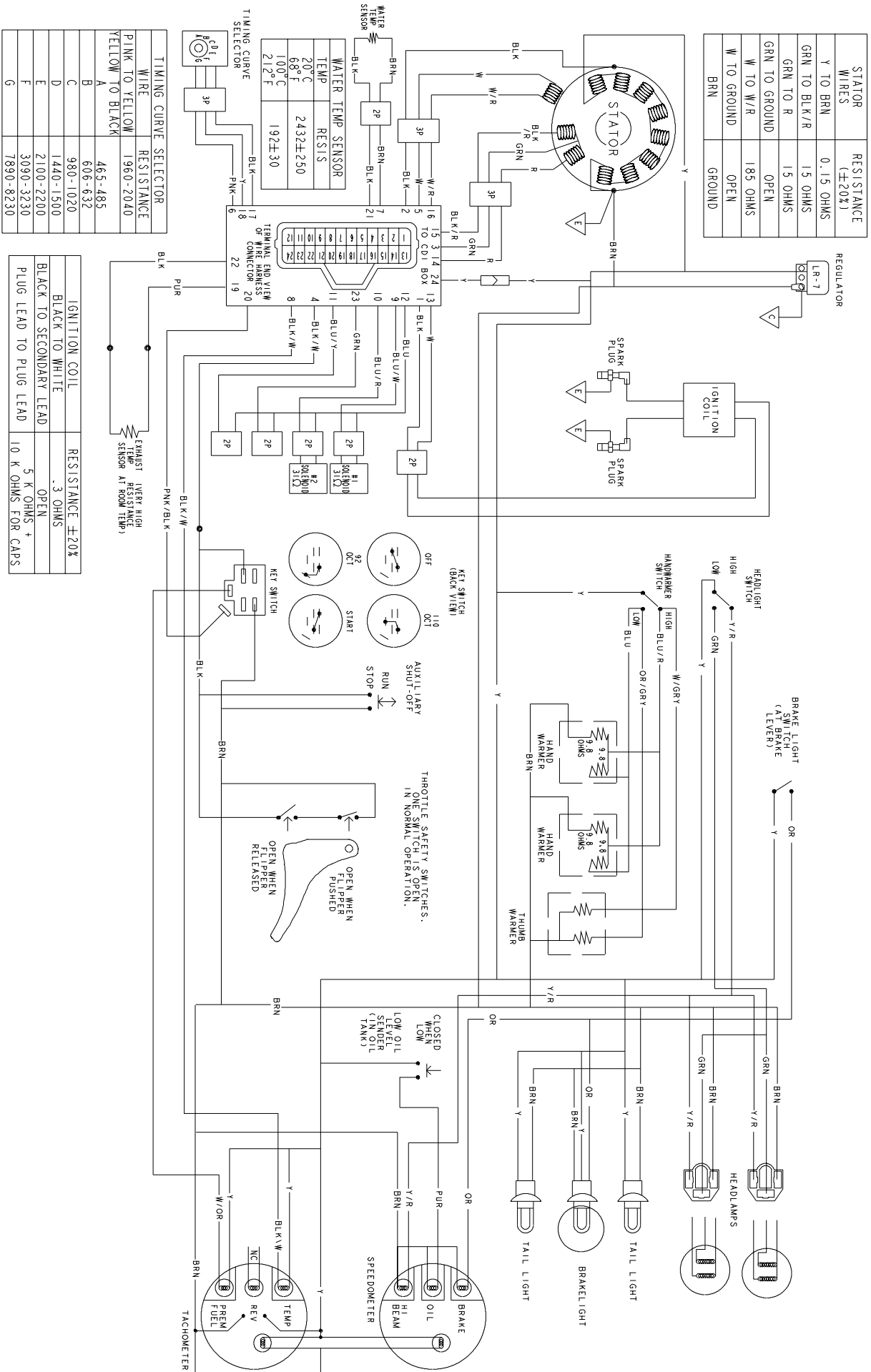

STATOR WIRES	RESISTANCE (±20%)
Y TO BRN	0.15 OHMS
GRN TO BLK/R	15 OHMS
GRN TO R	OPEN
W TO W/R	185 OHMS
W TO GROUND	OPEN
BRN	GROUND

TIMING CURVE SELECTOR WIRE	RESISTANCE
PINK TO YELLOW	1960-2040
YELLOW TO BLACK	465-485
A	606-632
B	980-1020
C	1440-1500
D	2100-2200
E	3090-3230
F	7890-8230
G	

IGNITION COIL	RESISTANCE ±20%
BLACK TO WHITE	.3 OHMS
BLACK TO SECONDARY LEAD	OPEN
PLUG LEAD TO PLUG LEAD	5 K OHMS + 10 K OHMS FOR CAPS

Free Manuals Download Website

<http://myh66.com>

<http://usermanuals.us>

<http://www.somanuals.com>

<http://www.4manuals.cc>

<http://www.manual-lib.com>

<http://www.404manual.com>

<http://www.luxmanual.com>

<http://aubethermostatmanual.com>

Golf course search by state

<http://golfingnear.com>

Email search by domain

<http://emailbydomain.com>

Auto manuals search

<http://auto.somanuals.com>

TV manuals search

<http://tv.somanuals.com>