

Requires 120 Volt 60Hz Power Supply.  
Draws less than 5 Amps

NOTE: SEE INSTALLATION MANUAL FOR PIPING DIAGRAMS.

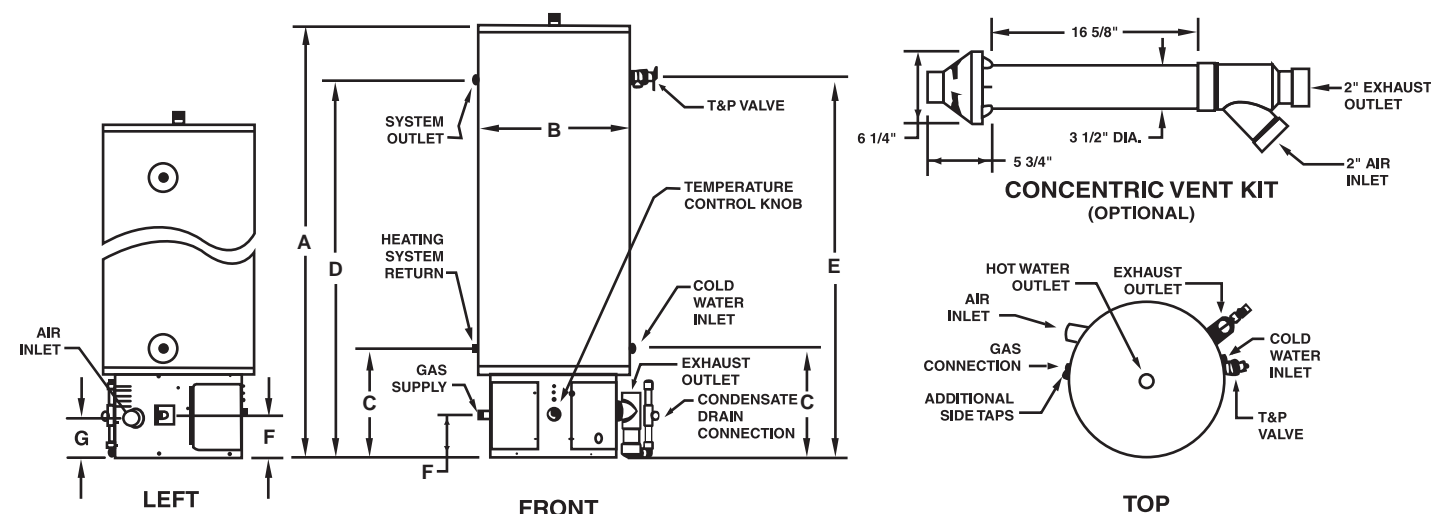

## 10-Year Residential Polaris®

Note: Dimension 'G' = 5 3/4"

MODEL NUMBER	TANK CAP. (GAL.)	INPUT BTU PER HOUR	THERMAL EFFICIENCY	G.P.H. REC. 90° RISE	EXTERIOR A	B	1" WATER CONNECTIONS C	D	T & P HGT. E	1/2" GAS SUPPLY F	APPROX. SHIP WT.
PR100-34-2NV	34	100,000	96	129	48.5	22	15.75	40.5	41	6-1/8	150
PR130-34-2NV	34	130,000	96	166	48.5	22	15.75	40.5	41	6-1/8	150
PR130-50-2NV	50	130,000	95	166	62.5	22	15.75	54.5	55	6-1/8	176
PR150-34-2NV	34	150,000	95	188	48.5	22	15.75	40.5	41	6-1/8	150
PR199-100-3NV	100	199,000	96	257	70	28	23.25	56.25	63	6-3/8	486

For propane, substitute "P" for "N" in the model number. 3" Concentric Vent Part #6910543 or 2" Concentric Vent Part #6910542. Specifications are subject to change without notice in accordance with our policy of continuous improvement. Input, output and recovery may vary depending upon air inlet and exhaust outlet installations. Length and number of bends in inlet and outlet pipes may reduce input and output. Consult installation, operation and service manual for details. Dimensions on all charts shown in inches.

### Specification

Residential gas-fired water heater(s) shall be a direct/power vent Polaris model \_\_\_\_\_ as manufactured by American Water Heater Company and shall have a 10-year limited tank warranty and a 1-year limited parts warranty, as outlined in the written warranty. Units shall be designed to burn \_\_\_\_\_ (natural/propane) gas and be CSA International certified to the latest edition of ANSI standard Z21.10.3/CSA 4.3. Water heater(s) shall have a nominal storage capacity of \_\_\_\_\_ gallons and a recovery rate of \_\_\_\_\_ GPH @ 90°F rise with a rated input of \_\_\_\_\_ BTU/Hr. Water heater(s) shall be condensing type with a minimum thermal efficiency of 95-96%, power vented with PVC, ABS, or CPVC pipe. Water heater(s) shall have combined vent capabilities of up to 120' to the exhaust outlet with up to 120' to the air inlet. Water heater(s) shall have a low noise combustion system with a woven fibre steel burner capable of low NOx (less than 40 ng/j) in the blue flame mode and shall be manufactured of refractory steel, resistant to thermal and mechanical shock. The gas valve shall be a Honeywell CV1-r1 series gas valve with a matching 45,900 series venturi manifold using a 1:1 air/gas ratio. The combustion system shall be factory adjusted and require no field adjustment on startup. The tank shall be constructed of 444 stainless steel with a submerged combustion chamber and rated for 150 PSI working pressure and 300 PSI test pressure. The tank shall be surrounded by two inches of non-CFC foam insulation covered by an enamel coated metal jacket. Operating controls shall have a 24-volt integrated control circuit, an immersed thermistor temperature sensor, a recycling energy cut-off switch, external temperature adjustment, and shall have LED lights that continuously indicate the operational status of the water heater(s). A microprocessor shall automatically monitor nine critical operating functions and signal the status of each. A factory installed temperature and pressure relief valve shall be provided on all models. A factory provided water thermostatic tempering valve shall be provided with all models.

### Order Entry and Sales

GSW Water Heating  
A GSW Inc. Company  
599 Hill Street West,  
Fergus, ON, Canada N1M 2X1  
Tel: 1-888-599-2837

### Product Service and Support

P.O. Box 1597, 500 Princeton Road  
Johnson City, TN 37605-1597  
Tel: 1-800-456-9805  
Fax: 1-800-999-5210

### Distributed By

## HIGH-EFFICIENCY RESIDENTIAL GAS WATER HEATER 10-Year Tank Warranty 1-Year Parts Warranty

### •Stainless Steel Tank with Submerged Combustion

High grade 444 stainless steel tank with brass connections for years of dependable, trouble-free service - no anode required. Submerged combustion chamber with spiral flue for 95-96% thermal efficiency and ultra-low standby heat loss of approximately 1%.

### •Sealed Combustion with Woven Fibre Premix Burner

Metal fibre burner is designed for clean combustion in high-intensity blue flame mode. Manufactured of refractory steel that resists corrosion. Excellent resistance to thermal and mechanical shock, even at extreme temperatures. Uniform combustion provides excellent heat transfer. Meets Low NOx requirements for California and Texas.

### •Whisper Quiet Operation

Ultra quiet blower and burner minimize noise.

### •Power/Direct Vent Using 2" or 3" Plastic Pipe

Direct vents up to 120' using PVC, CPVC, or ABS pipe. Vents through-the-wall or roof. Optional concentric vent kit available for use through-the-roof or wall.

### •Plug-and-Play Technology

No special adjustments are required at initial start up. Connect air inlet, exhaust outlet, water, electricity, and gas, set the temperature and the system functions properly.

### •Self-Diagnostic Control System

Three external LED lights indicate operational status of water heater. Microprocessor monitors nine critical functions. An LED troubleshooting light, visible through view port, signals heater operation status.

### •Full Serviceability from the Front

Removal of two front-located access panels exposes all serviceable components. Modular components are easily removed.

### •Multiple 1" Tank Connections – Brass

Potable water and space heating connections provided. Use with potable water only.

### •Factory Provided Tempering Valve

Helps stretch hot water supply by automatically mixing hot and cold water.

### •Other Features

Thermister Temperature Sensor  
Hot Surface Ignition  
ASHRAE 90.1b-1992 Compliant  
Factory Installed T&P Valve  
Complies with California Title 24

24-Volt Thermostat Control  
Full Flow Brass Drain Valve  
Zero Clearance to Combustibles  
Factory Provided Condensate Trap (CPVC)

### •CSA International Certified to ANSI Z21.10.3/CSA 4.3

Copyright© by American Water Heater Company  
2002. All rights reserved.



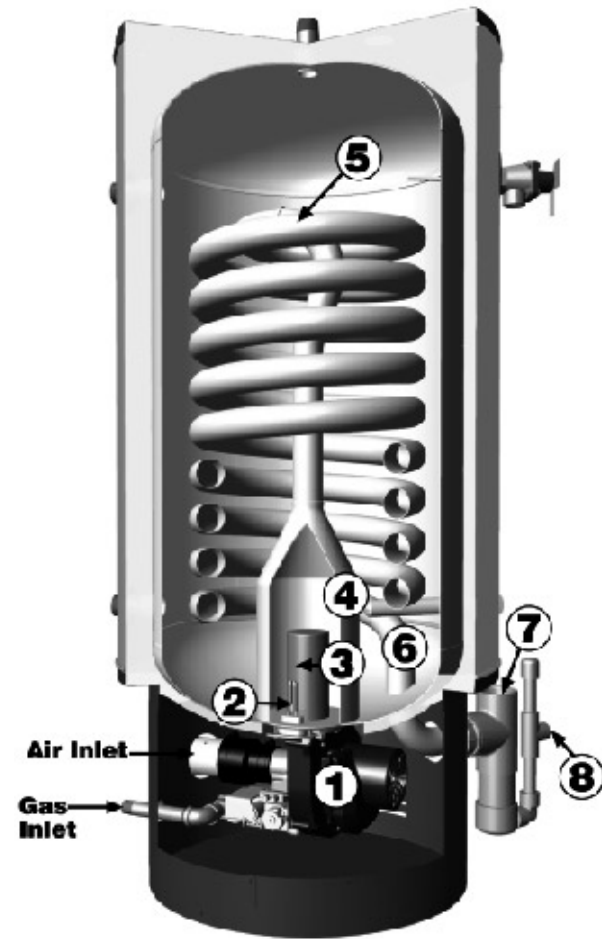

Air Inlet  
Gas Inlet

## 95+ % Efficient

1. The quiet, brushless DC blower prepurges the submerged combustion chamber for 8 seconds and turns off.
2. The hot surface igniter is energized and glows red hot.
3. The blower turns on, precisely mixing air and gas for combustion. The mixture is forced through the metal fibre burner and is ignited by the hot surface igniter. A blue flame is evenly distributed across the entire burner, resulting in clean combustion with low nitrous oxide emissions.
4. The combustion chamber wall transfers high temperature heat from the flame to the water.
5. The blower pushes hot combustion gases through the spiral coil, which scrubs the remaining heat from the hot gases.
6. As combustion gas exits the bottom of the spiral coil, it is barely warm to the touch. Over 95% of the heat from the flame is transferred to the water.
7. Combustion gases are vented through PVC, CPC or ABS plastic pipe.
8. Condensation formed by cooled combustion air is captured by a condensate trap and drained through a drain line.

## The Quiet Way to Efficiently Heat Water

An ultra quiet radial blower is combined with a submerged burner for whisper quiet operation. Indicator lights illuminate when the power is on and when the igniter and burner are operating.



## The Best Choice for Hot Water

Polaris is ideal for large homes. For dishwashing, showers, baths, clothes washing, or hot tubs, Polaris is the best choice. Polaris models heat up to 257 GPH at a 90°F temperature rise, compared to 41 GPH for standard gas water heaters.



## Polaris Combines Water Heating with Space Heating



## Radiant Hydronic Heat

Polaris works great for homeowners who prefer radiant hydronic heat. With radiant floor hydronic systems, potable hot water is circulated through tubes under the floor. The floor absorbs heat from the tubes and radiates it into the room. With radiant baseboard heat, potable hot water is circulated through finned tube baseboard. Heat rises from the baseboard heaters, warming the home. All water components must be approved for use with potable water.

## Forced Air Hydronic Heat

Polaris can be used to combine an air handler for comfortable forced air hydronic space heating with potable hot water. Hot water is circulated through a coil in the air handler. Air from the home is warmed as it is blown across the coil. Warmed air is returned to the home through air ducts. With up to 199,000 BTUs, Polaris can heat most homes, large or small.

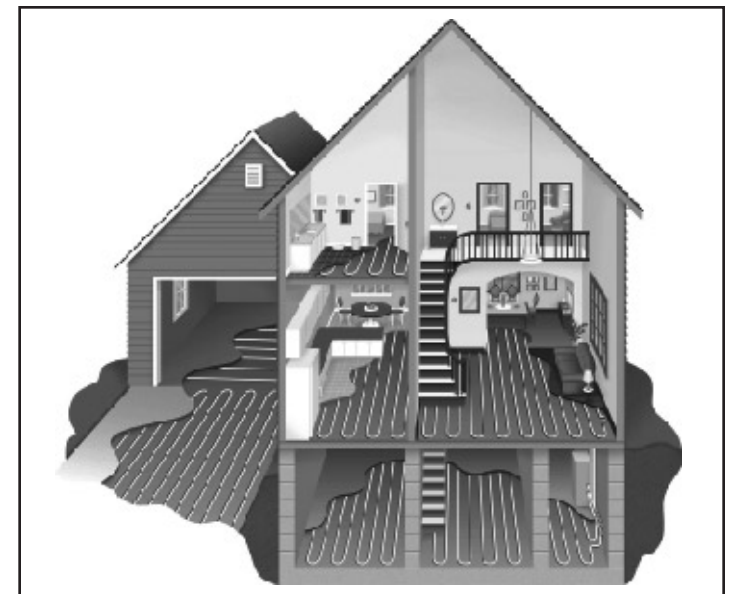

Illustration provided by Uponor Wirsbo

## Free Manuals Download Website

<http://myh66.com>

<http://usermanuals.us>

<http://www.somanuals.com>

<http://www.4manuals.cc>

<http://www.manual-lib.com>

<http://www.404manual.com>

<http://www.luxmanual.com>

<http://aubethermostatmanual.com>

Golf course search by state

<http://golfingnear.com>

Email search by domain

<http://emailbydomain.com>

Auto manuals search

<http://auto.somanuals.com>

TV manuals search

<http://tv.somanuals.com>