



INTRODUCTION MANUAL

**MOSFET 2-CHANNEL POWER AMPLIFIER
WITH ELECTRONIC CROSSOVER AND
VARIABLE SUB CONTROL**

A2•200W 200 WATTS

A2•300W 300 WATTS

A2•400W 400 WATTS

INTRODUCTION

The POWER ACOUSTIK 2 Channel Series of Power Amplifiers was designed for maximum flexibility at an affordable price. The three models in this series share the same features and general appearance, differing only in output power capability and chassis length.

MODEL	Maximum Output Power
A2•200W	200 Watts
A2•300W	300 Watts
A2•400W	400 Watts

These Maximum Power ratings are useful for comparison with models of other brands that use this rating system. Refer to the Specifications Section that follows for the Technical performance details.

Each model has 3 possible Output Modes (Stereo, Bridged Mono or both) and 3 possible Crossover Modes (Full Range, Low Pass or High Pass). Initially, you might use it to drive the Left & Right Rear Speakers in Full Range or a single Subwoofer in Bridged Mono Low Pass. If economy is most important, a single unit can handle both jobs (Stereo + Mono) with the addition of speaker crossover networks as shown in Figure 5.

Later as your system grows, the same model can be reassigned to Left/Right Front or Rear Speakers in High Pass or to a single or dual Subwoofer in Low Pass. You can switch out the Crossover section and add a more elaborate external Electronic Crossover or Signal Processor. It will not become obsolete.

OPERATING CONTROLS AND FEATURES

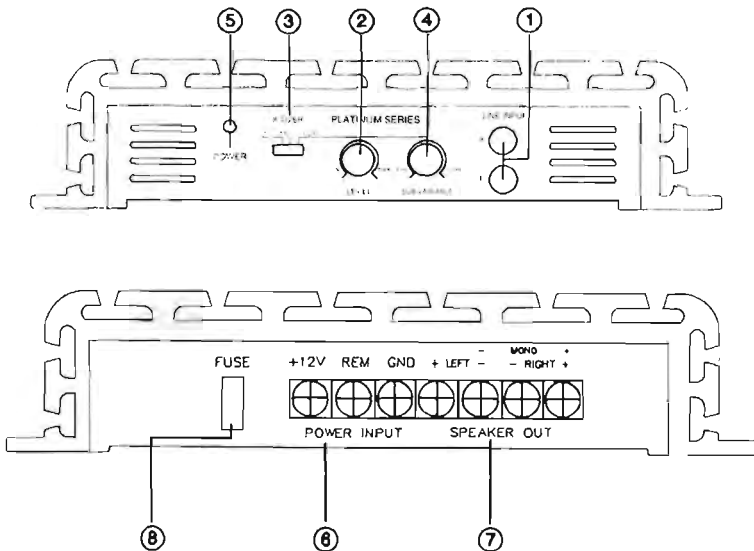

Figure 1

1. Line Inputs. These are driven by the line outputs of your indash radio or intermediate signal processor. Separate Left and Right signals can be applied for Stereo or Mono operation but both inputs must be driven with the same signal for proper Bridged operation. If only one mono signal is available, a "Y" adapter is required as shown in Figure 3.
2. Input Sensitivity Controls. Used to set overall gain of the unit to match the actual signal levels available at the Inputs and to permit balancing with other amps in the system.
3. Crossover Mode Selectors. The choice of High Pass (150 Hz) Full Range or Variable Low pass (30 Hz - 120 Hz).
4. CROSSOVER CONTROL. Adjusts crossover frequency of LOW PASS (SUBWOOFER) output only, from 30 Hz to 120 Hz.
5. Power On LED. Lights to confirm that the unit is active.
6. The Power Input and Control Terminals. See Figure 3 - Wiring Details.
7. The Speaker Output Terminals. See Speaker Connections section.
8. Primary Fuse. Provides protection against abnormally high current due to overloaded Speaker Output Terminals or internal fault. The fuse rating is 15, 20 or 25 amp depending on the model.

INSTALLATION

The units are normally mounted in the trunk of a vehicle and directly drives the rear speakers. See Figure 2. Select a flat surface and locate the chassis so the controls and connection points are accessible. Use the amplifier chassis as a template to mark the four mounting hole locations - then set it aside. A 1/8" drill size is recommended but take care in drilling these holes to avoid damage to the fuel tank or hydraulic lines which may be hiding just below the chosen mounting surface. If you cannot be certain, then consult with a local car dealer familiar with your model.

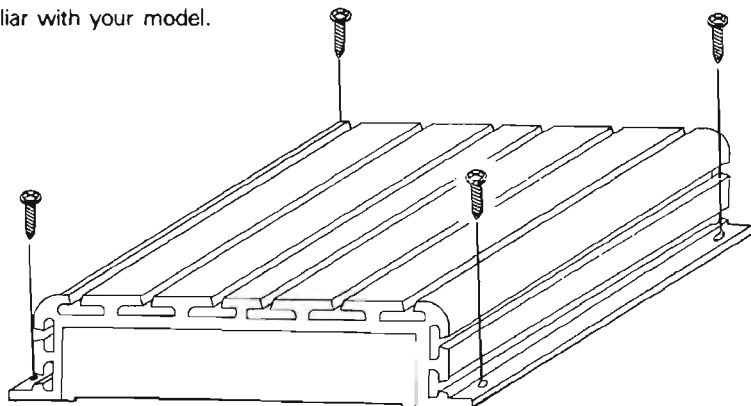

Figure 2 - MECHANICAL INSTALLATION

The black sheetmetal screws provided are intended to pass thru the clearance holes in the upper heat radiator and engage with the lower section. Four black rubber washers with adhesive backing are also provided. Fix them to the amplifier bottom surface centered on each hole prior to mounting. They help to compensate for an uneven mounting surface and improve airflow under the unit.

WIRING DETAILS (See Figure 3)

- **Power Ground (GND).** This Terminal is connected directly to the vehicle chassis using a heavy duty stranded wire of 12 GAUGE size or larger (lower gauge number). The standard color would be Black. Trim this Black wire so the length is just enough to reach a nearby chassis bolt head. Sand away any paint for a solid electrical connection.
- **Main Power (+ 12V).** This Terminal is connected directly to the (+) terminal post of the vehicle battery. Again, it should be heavy duty 10 to 12 GAUGE stranded wire but with an inline fuse holder capable of accepting a 25 AMP fast blow fuse. This fuse should be located as close to the battery post as possible.

This heavy wire (Red is the standard color) has a long journey from the engine compartment to the trunk and there is always some risk that it may become shorted to the chassis somewhere along its length. By locating the fuse at the battery side of the wire, you insure that it will blow if a cable short occurs at any point. The fuses included in the amp chassis do not protect against cable shorts.

The task of hiding a heavy gauge wire under your carpeting may prove difficult in some cases. If uncertain how to proceed, seek the assistance of a professional Autosound installer. Also, use cable clamps as required to keep this wire away from moving engine parts or hot surfaces. Do not insert this inline fuse until all connections are completed and inspected.

- **REMOTE (REM).** The unit is turned on by applying +12 volts to this Terminal. This terminal does not draw heavy current like the two Power Terminals so a thinner connecting wire is acceptable. Stranded 18 GAUGE is fine and the standard color is Yellow. If the radio is equipped with a Power Antenna control wire, it can drive this terminal. If the Power Antenna wire is already in use, you can still splice into it. With this method, the unit will turn on automatically with the radio.

If there is no Power Antenna wire, then connect REMOTE to a +12 volt source that is switched Off when the vehicle Ignition is off. This will assure that the amplifier does not drain the battery when the engine is not running. Connection can be made at the vehicle fuse block using the IG or ACC terminals. Do not use the cigarette lighter circuit because this is normally On at all times.

- **Signal Input Connections.** Left and Right Line Level Input Signals are applied to the Line In Phono Jacks (See Figure 3). These are normally taken from the Line Out jacks of the indash radio or intermediate signal processor such as a passive equalizer. Extension cables with phono plugs on both ends are required. These can be purchased in a variety of lengths at any audio shop at nominal cost.

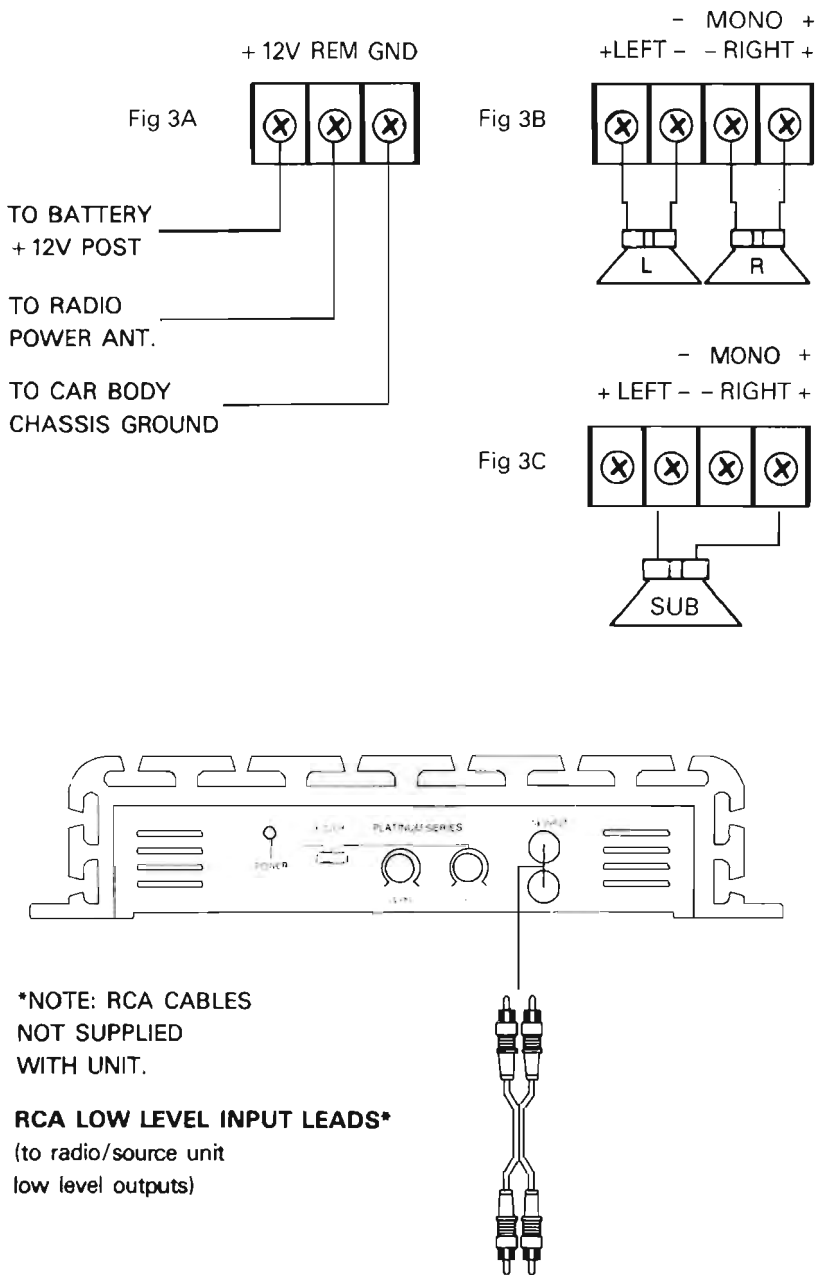

Figure 3. WIRING DETAILS

Speaker Connections. The details depend on which of the three Output Modes you will use. Figure 3 shows the proper speaker and input connections for the Stereo and Bridged Mono Mode using the Low Input jacks.

- A. In Figure 3B, note that the two speakers (Left and Right) have been connected to the four terminals following the (+) and (-) graphics. Your speaker terminals may be marked (+) and (-) or there may be a red dot by one terminal which means the same as (+). Connecting the speakers in this manner assures that the two speaker cones will move in and out together according to the original recording. If one of the two speakers is reversed, stereo imaging and bass response will be degraded.
- B. Figure 3C shows a single Subwoofer connected according to the MONO (+) and (-) graphics. This is the second Output Mode and the other two terminals are not used. A single 4 ohm subwoofer or two 8 ohm subwoofers in parallel can be connected. If you have two 4 ohm subwoofers, they should be connected in the Stereo Mode per Figure 3B.

On the input side, the important point is that both the Left and Right Inputs are driven with the same single. If one input is left open, you will not get the full bridged output power.

- C. The Stereo + Mono Output Mode is shown in Figure 5. In this case, one amplifier is driving both the Subwoofer in bridged mono and the Left & Right speakers in stereo. The internal Crossover must be set to the Flat position and the Left/Right Inputs are full range stereo. The low and high frequencies are separated at the amplifier outputs by a passive crossover network. This is very important for two reasons.
- To keep the deep bass out of the smaller Left/Right speakers, avoiding cone distortion and possible speaker failure.
 - To keep the lower midrange signal out of the Subwoofer, avoiding loss of stereo separation.

The advantage of this Mode is economy. The cost of a passive crossover should be less than a second amplifier. The disadvantage is in performance but only if you set the volume too high and cause bass clipping. In a typical, two amplifier system, bass clipping causes bass distortion but does not affect the midrange/treble (vocals & other instruments). When you ask one amplifier to carry the full frequency range, then any bass clipping will cause severe distortion of the entire signal. If you do not overdrive the amplifier, this Output Mode works fine and saves money.

**DO NOT CONNECT ANY SPEAKER OUTPUT TERMINAL
TO VEHICLE GROUND OR BATTERY (+) !**

FINAL STEPS

- With the Ignition still OFF and before inserting the inline fuse in the heavy + 12 volt cable near the battery, carefully inspect all connections.
- Locate the two Input Sensitivity Controls (Items 3 - LEVEL) and preset them to 50% rotation.
- Complete the + 12 volt connection by inserting the inline fuse in the holder that you provided. A small spark would be normal as the amplifier filter capacitors charge up. If the fuse blows, then there is a major fault! Check if the fuse on the amplifier end and panel are also blown. If yes, the fault is in the amplifier. If not, the heavy 12V cable is shorted to the vehicle somewhere.
- If OK so far, turn the Ignition Switch to the Accessory position and turn on your Source Unit (indash radio) but keep the volume down. Verify that the Red Power On LED (Item 5) has turned on. If not, check the Remote and heavy GND connections.
- Advance the Source Unit's volume. You should be getting sound now. If not, check the Signal Input connections. If OK at this point, rotate the Source Balance control to confirm proper Left-to-Right action. If reversed, either the input or output connections could be the cause.
- If any of the speaker connections are shorted together, the unit will sense this as soon as you begin to drive it and respond by shutting down all channels. The Red LED will turn off even if the Source unit is still on.
Then it will turn on again to see if the short has been cleared. It will continue to pulsate until you turn off the Source and correct the cause of the short. The speaker that produced little or no sound while the amplifier was pulsating is probably the culprit so start there.
- Set the radio Tone or Equalizer controls to their normal positions. Advance the Volume to see if the maximum desired listening level can be reached. If yes, then no further adjustment is required. If not, then advance the INPUT LEVEL controls slowly until satisfied. Do not set more gain than actually needed because low-level noise from the Source will also be amplified more.
- If you have been running at high volume for an extended time in hot weather, the unit may overheat to the point where it must shut itself off to prevent component damage. This will happen if the outer surface of the Heat Radiator reaches about 185 degrees F (85 degrees C). That is much too hot for bare skin so if the unit shuts down unexpectedly, do not touch the unit! You will feel the radiant heat just by coming near it.
The unit will come back on by itself in a few minutes. When it does, you should reduce the volume level or it will just shut down again.

NOISE SUPPRESSION

Three types of noise problems may occur due to the addition of a Power Amplifier. Generally, the noise was there all along but may not have been noticed until the amplifier raised its level.

White Noise is a hissing sound heard at low volume levels or during quiet passages. It is even more noticeable with the engine off. The best way to avoid this problem is by setting the LEVEL Control to the lowest workable position and operate the Source at a higher volume setting.

Alternator Whine is a steady tone whose pitch increases with engine speed. It is actually produced by your vehicle's charging system. This unwelcome tone can enter your source unit thru its power connections and produce a small output at the speaker or line outputs. An external amplifier must accept it as a normal input signal and possibly raise it to an audible level. The solution given above for white noise is also helpful here. If not, a supplementary power line filter for the source unit may be necessary.

Ignition Noise is radio frequency interference produced by your engine's ignition system that can radiate into your antenna and cause a popping sound during FM reception, especially if the particular FM signal is weak. It always goes away during CD or Tape modes. It has nothing to do with the unit but the addition of an external amp and high performance speakers can make it sound more annoying. There are specific things that your car dealer or autosound specialist can do under the hood to reduce this radiated interference.

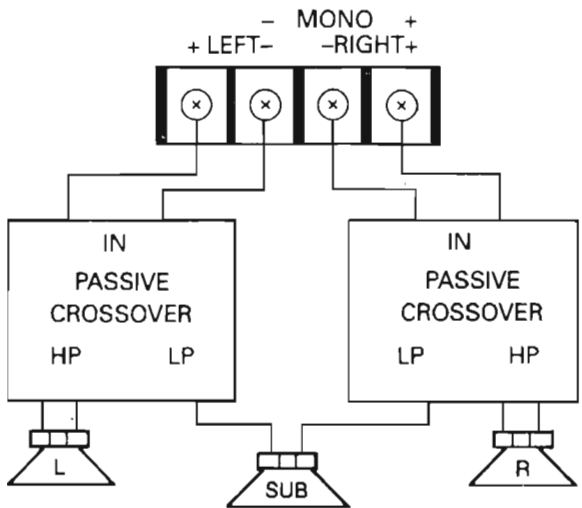

Fig 5. THE STEREO + MONO MODE

SPECIFICATIONS

Output Power	4 Ohms RMS	2 Ohms RMS	Bridged
A2•200W	: 60 watts x 2	75 watts x 2	200 watts x 1
A2•300W	: 85 watts x 2	95 watts x 2	300 watts x 1
A2•400W	: 125 watts x 2	155 watts x 2	400 watts x 1
Frequency Response	: 20 Hz to 30 kHz, +0/ -1 dB.		
@ 1 watt full range			
Crossover	: Separate Low + High Pass Filters		
— High Pass	120 Hz FIXED		
— Low Pass	30 Hz ~ 120 Hz Variable		
Crossover Rate	: 12 dB/octave		
Signal/Noise Ratio	: Better than 90 dB A-Weighted.		
Input Impedance (ohms)	: 10K Low Level, 200 High Level.		
Input Sensitivity	: 100 mV to 1 volts Low Level. 0.5 volt to 5 volts High Level.		
Power Requirements	: 11 to 16 VDC, negative ground. 40 amps maximum.		
Accessories included	: Mounting hardware, high level input cable. All power, control and low level input cables must be purchased separately."		
Dimensions (L x W x H)	A2•200W	A2•300W	A2•400W
inches	: 8.2 x 10.0 x 2.2	9.1 x 10.0 x 2.2	12.2 x 10.0 x 2.2
mm.	: 208 x 254 x 55	230 x 254 x 55	310 x 254 x 55
Weight	: 5.1 lbs, 2.3 kgs	5.7 lbs, 2.6 kgs	7.7 lbs, 3.5 kgs

Free Manuals Download Website

<http://myh66.com>

<http://usermanuals.us>

<http://www.somanuals.com>

<http://www.4manuals.cc>

<http://www.manual-lib.com>

<http://www.404manual.com>

<http://www.luxmanual.com>

<http://aubethermostatmanual.com>

Golf course search by state

<http://golfingnear.com>

Email search by domain

<http://emailbydomain.com>

Auto manuals search

<http://auto.somanuals.com>

TV manuals search

<http://tv.somanuals.com>