

## SPECIFICATION

### AMPLIFIER

Power Output:	100W
Receiving mode:	VHF
Frequency Range:	160~270MHz
S/N Radio:	60dB
Power Supply:	AC 120V/60Hz DC 12-15V
Output Impedance:	600Ω
Operating Range:	30M

### TRANSMITTER

Frequency Range:	160~270MHz
Dynamic Range:	80dB
Frequency Response:	100-10KHz
Working Temperature:	-10°C -45°C
Power Supply:	9V battery
Battery time	8~10 hours

[WWW.PYLEAUDIO.COM](http://WWW.PYLEAUDIO.COM)

**PYLE<sup>®</sup>**  
**PRO**

**PWMA110**

## WIRELESS RECHARGEABLE PORTABLE AMPLIFIER



**USER'S MANUAL**

## FEATURES

- \* Built-in 12V 1.2A Rechargeable Battery
- \* Built-in One Channel VHF Wireless Receiver
- \* With One Handheld MIC
- \* With One 6.35mm Wired MIC input Jack and 6.35mm CD input Jack
- \* Separate Wired MIC, Wireless MIC and CD input Volume Controls
- \* With 6.35mm REC out Jack
- \* With Treble, Bass and Echo Controls
- \* Power, RF and Charge LED Indicators
- \* Power ON/OFF Switch
- \* Power Supply: AC 120V/60HZ, DC12~15V or battery Powered(8 "D" batteries)
- \* Power output: 100W
- \* Frequency Range: 160~270MHz
- \* Operating Range: Up to 100ft.

## CAUTION

1. Keep this device away from high temperature. Don't expose this device to direct sunshine or near the hot equipment.
2. Don't place the device in the environment of humidity and dirt.
3. Place the device in the ventilated environment.
4. Don't pull the power cord while unplug the device. Please hold the plug to unplug.
5. Unplug the device from mains power supply if you will not use the device for a long time.
6. Your operation must be subjected to the specified voltage marked on the device and complied with this manual.
7. Don't open chassis! It is very dangerous either open the chassis or put your hand inside the chassis. If the device is not working properly, unplug the device at once and contact your retailer or the nearest distributor.

## PARTS DESCRIPTION

### Front

1. Antenna: to receive signal from wireless transmitter
2. Power switch
3. ECHO control
4. MIC input jack
5. AUDIO input jack
6. Speaker
7. Recording signal output
8. BASS control
9. TREBLE control
10. Audio Input volume control
11. Wired MIC volume control
12. Wireless microphone volume control
13. RF LED indicator of wireless microphone
14. Power LED indicator

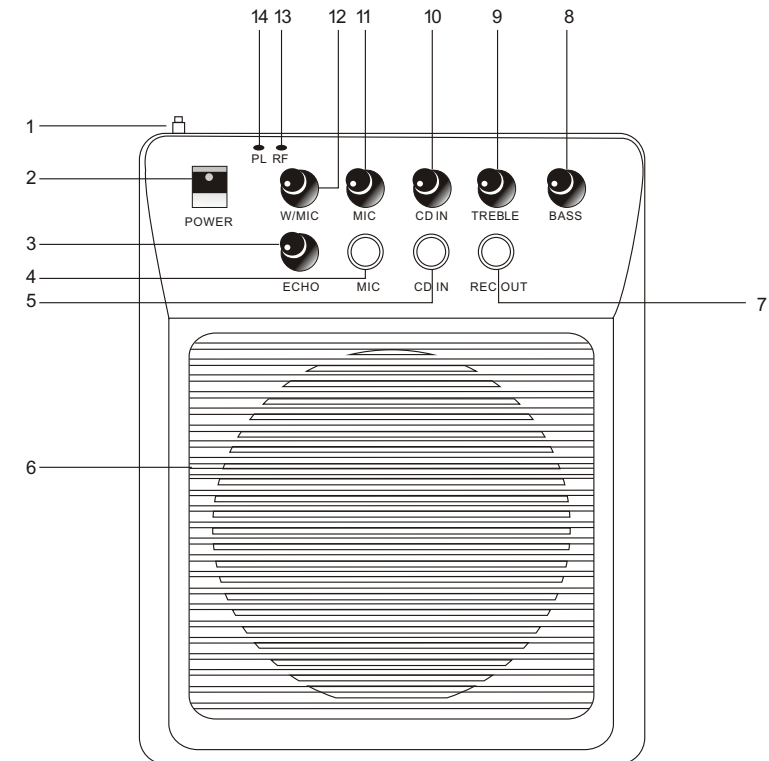

## PARTS DESCRIPTION

### Rear

- |                                      |                          |
|--------------------------------------|--------------------------|
| 15. Rechargeable battery compartment | 19. Stand mounting hole  |
| 16. Compartment for AC cord          | 20. Battery compartment  |
| 17. AC Input jack                    | 21. DC input jack        |
| 18. Fuse                             | 22. Charge LED indicator |
|                                      | 23. Rating label         |

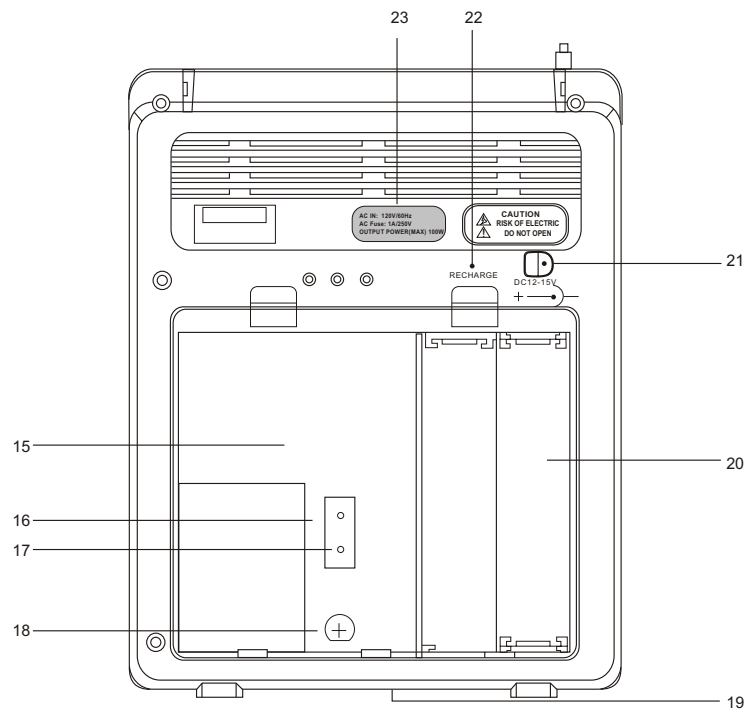

## OPERATION INSTRUCTIONS

### 1. Confirm the power

- 1) AC power (17): Before use, please make sure the voltage of power supply is the same as that indicated (23) on the amplifier. Or it will cause damage to the system.
- 2) DC Input (21): DC power can be connected to DC input jack. If car power is used, the voltage should be 12V-15V. Please pay attention to correct polarity(negative/positive).

**Remark:** When insert the DC plug to DC input jack, the battery power is cut off automatically.

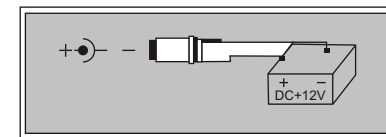

### 3) Battery power(20):

This unit can also be powered by 8pcs "D" size alkaline batteries (SUM-1)

**Remark:** Low battery power and voltage will cause distortion and short reception distance.

2. Before turn on the main unit, please turn Echo, treble, bass and all volume controls anticlockwise to minimum. Then switch it on. After signal is input or wireless microphone is turned on, then adjust the volume to a suitable level. Adjust ECHO, BASS, TREBLE controls to reach the idea sound quality.

## OPERATION INSTRUCTION

### REMARKS

1. When feedback occurs, please turn down the Treble, Echo controls. If feedback still exists, turn down the volume control slightly to improve the feedback situation.
2. The wired microphone and wireless microphone can be used at the same time.
3. CD IN(5) can connect with portable Radio, CD player, VCD player and other audio sources.
4. REC out(7) can connect with recorder for site recording or with the output jack of power amplifier to enlarge the power.

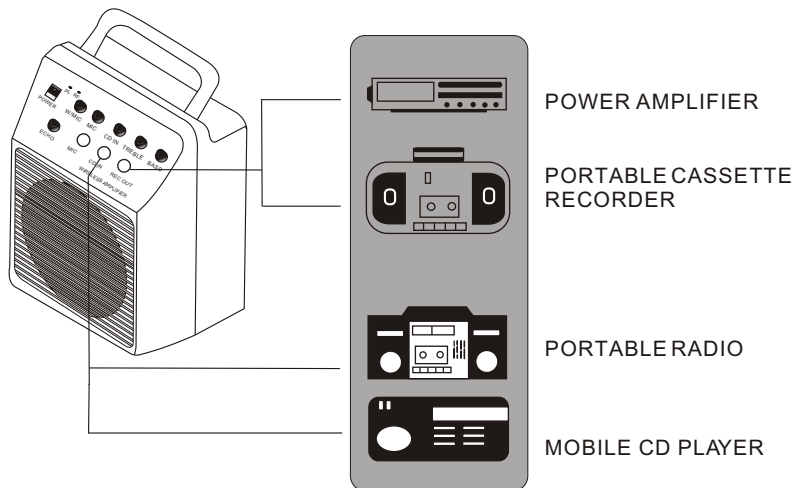

## OPERATING INSTRUCTION

1. When use AC power, rechargeable battery can be charged at the same time.
2. Don't use dry battery and AC power at the same time.
3. If battery power is low, receiving distance will be shortened and sound will become abnormal. Please change battery immediately.
4. Don't forget to switch off the system to avoid extra power consumption when it is not used.
5. Don't use batteries of different models or old and new batteries together.
6. Take out the batteries if the system will not be used for a long time. Otherwise the system may be damaged by the leakage of degenerative batteries.
7. This unit can be mounted on triangle stand(not included).

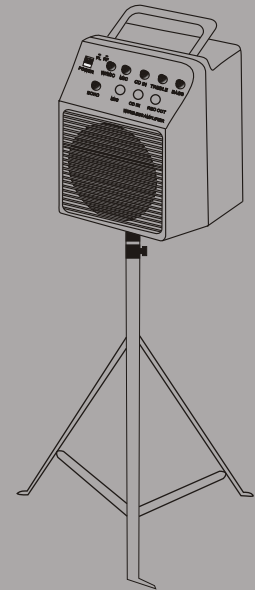

## Free Manuals Download Website

<http://myh66.com>

<http://usermanuals.us>

<http://www.somanuals.com>

<http://www.4manuals.cc>

<http://www.manual-lib.com>

<http://www.404manual.com>

<http://www.luxmanual.com>

<http://aubethermostatmanual.com>

Golf course search by state

<http://golfingnear.com>

Email search by domain

<http://emailbydomain.com>

Auto manuals search

<http://auto.somanuals.com>

TV manuals search

<http://tv.somanuals.com>