



User's Guide User's Guide User's Guide User's Guide User's Guide User's Guide

LTO-3 Tape Drive

LTO-3

50002764 B01

Quantum LTO-3 Tape Drive User's Guide, P/N 50002764, B01, July 2005
Made in USA.

Quantum Corporation provides this publication "as is" without warranty of any kind, either express or implied, including but not limited to the implied warranties of merchantability or fitness for a particular purpose. Quantum Corporation may revise this publication from time to time without notice.

COPYRIGHT STATEMENT

Copyright 2005 by Quantum Corporation. All rights reserved.

Your right to copy this manual is limited by copyright law. Making copies or adaptations without prior written authorization of Quantum Corporation is prohibited by law and constitutes a punishable violation of the law.

TRADEMARK STATEMENT

Quantum and the Quantum logo are all registered trademarks of Quantum Corporation.

Other trademarks may be mentioned herein which belong to other companies.

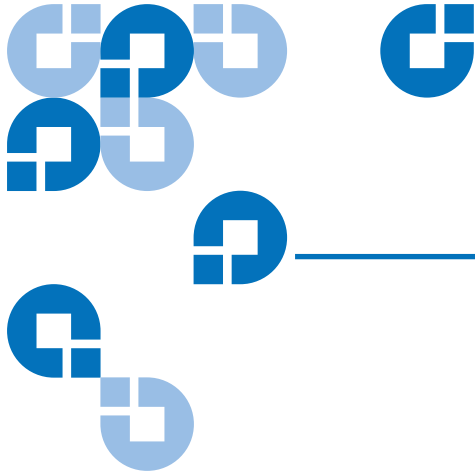

Contents

Preface	xi
----------------	-----------

Chapter 1	Overview, Unpacking Instructions and Quick Start	1
	Overview	1
	Drive Configurations.....	2
	Features	2
	Unpacking and Inspection.....	3
	Quick Start Guide	4
	Internal LTO-3 Tape Drive Quick Start	4
	Desktop LTO-3 Tape Drive Quick Start	5
	Internal Tape Drive Guidelines and Cautions.....	5

Chapter 2	Installation	7
	Drive Installation Instructions	7
	Installing an Internal LTO-3 Tape Drive	8
	Configuring an LVD Drive.....	8
	Mounting the Internal LTO-3 Tape Drive.....	11
	Connector Detail	12
	ADI Free Cable Connector.....	13

Connecting a SCSI Cable.....	14
Checking the SCSI Termination.....	15
Connecting a Serial Cable for Tape Libraries.....	16
Bus Composition.....	17
Connecting a Power Cable.....	18
Installing the LTO Driver.....	18
Registering Your Tape Drive.....	18
Installing a Desktop LTO-3 Tape Drive.....	18
Setting the SCSI ID.....	19
Connecting a SCSI Cable.....	19
Checking the SCSI Termination.....	20
Connecting a Power Cord.....	21
Installing the LTO Driver.....	21
Registering Your Tape Drive.....	21

Chapter 3	Operation	23
------------------	------------------	-----------

Understanding the Front Panel Display.....	24
Blink Codes.....	25
Using LTO Cartridges.....	26
Loading a Cartridge.....	26
Unloading a Cartridge.....	26
Write-protecting a Cartridge.....	27
Cartridge Care and Maintenance.....	28
Drive Maintenance.....	28
Cleaning the Tape Drive.....	29
Parking the Drive for Shipping.....	30
Using the Load/Unload Button to Park the Drive.....	30
Using Software to Park the Drive.....	30

Chapter 4	Theory	31
------------------	---------------	-----------

Track Layout.....	31
Recording Method.....	33
Data Buffer.....	33
Data Integrity.....	33
Error-correction Code (ECC).....	34
Servo-tracking Faults.....	35

Data Compression.....	35
Data Compression Considerations.....	36
Intelligent Data Compression	37

Chapter 5 Specifications 39

Physical Specifications	40
Power Specifications.....	42
Drive Performance Specifications.....	43
Environmental Requirements	44
Injected Noise	45
Reliability	45
Mean Time Between Failures	46
Mean Time to Replace.....	47
LTO Cartridge Specifications	47
Environmental Considerations	47
Cartridge Memory	48
Cartridge Reliability	48
Regulatory Compliance	48
Safety Compliance	48
Electromagnetic Compatibility (EMC)	50
Disposal of Electrical and Electronic Equipment	51

Chapter 6 UNIX Settings 53

A Word About SCSI Controllers.....	54
Configuring for the DEC/Compaq UNIX Environment	54
Finding Existing SCSI Controllers and Devices	54
Configuring Digital UNIX Version 4.0 and later/Compaq Tru64 Unix 5.x.....	54
Configuring for the Sun Environment (Solaris 2.4, 2.5, 2.6, 7, 8, and 9)...	55
Finding Current SCSI Controllers and Targets	55
Types of Controllers	56
Configuring the Device File st.conf.....	56
Configuring for the IBM AIX Environment (AIX Version 4.1.x and later)	58
Finding Existing SCSI Controllers and Devices	58
Configuring the LTO-3 Tape Drives using SMIT.....	58
Configuring for SCO Open Server 5.0.x	59

Finding Existing SCSI Controllers and Devices	59
Configuring the LTO-3 Tape Drive with mkdev	60
Configuring for Linux.....	61
Finding Existing SCSI Controllers and Devices	61
Using the LTO-3 Tape Drive	62
Configuring for SGI Irix	63
Finding Current SCSI Controllers and Targets.....	63
Modifying the IRIX Configuration File.....	63
Configuring for HP-UX 11.0	64
Finding Current Hardware/Driver Configuration.....	64
Attaching the LTO-3 Tape Drive	64

Chapter 7	Troubleshooting Guide	67
------------------	------------------------------	-----------

Installation Best Practices	67
Follow SCSI Best Practices	67
SCSI Host Bus Adapters (HBA)	67
Adding the Tape Drive.....	68
Troubleshooting Suggestions	69
Computer will not Boot.....	69
Computer Boots but Does Not Recognize the Tape Drive.....	69
Tape Drive Recognized During System Boot But Not by Operating System or Application.....	71
Problems with Tape Drive and Cartridge	72
Emergency Reset and Emergency Cartridge Eject	75
Problems During Backup/Restore Operations	75

Index	81
--------------	-----------

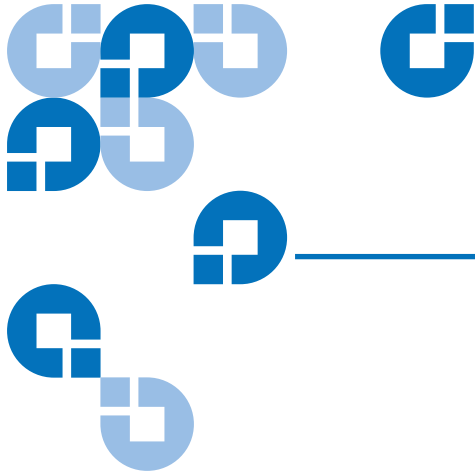

Figures

Figure 1	Typical Internal and Desktop Configurations	2
Figure 2	Internal LTO-3 Tape Drive Jumper Settings.....	9
Figure 3	Acceptable Mounting Orientations	11
Figure 4	Internal LTO-3 Tape Drive Mounting Dimensions	12
Figure 5	ADI Fixed Board Connector	13
Figure 6	ADI Free Cable Connector	14
Figure 7	Rear View of the Internal LTO-3 Tape drive	15
Figure 8	Two SCSI Termination Examples for the Internal LTO-3 Tape Drive	16
Figure 9	Switches and Connectors on the Back of the Desktop LTO-3 Tape Drive.....	19
Figure 10	SCSI Termination Examples for the Desktop LTO-3 Tape Drive	20
Figure 11	Generic Front Panel Display	24
Figure 12	Ultrium Cartridge Showing Write-Protect Switch	27
Figure 13	Layout of the Tracks on LTO Ultrium Tapes	32
Figure 14	Internal LTO-3 Tape Drive Dimensions.....	41

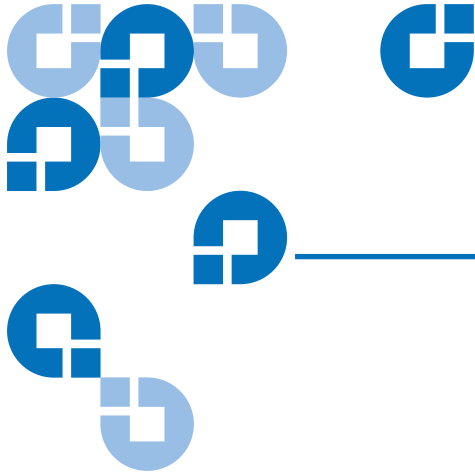

Tables

Table 1	ISCSI IDs and Jumper Settings for an Internal LTO-3 Tape Drive	9
Table 2	Serial Interface Connector Pin Assignments (LTO-3)	16
Table 3	ADT Bus Connections.....	17
Table 4	LTO-3 Tape Drive Blink Codes	25
Table 5	Physical Specifications.....	40
Table 6	Voltage and Current	42
Table 7	Power Dissipation	42
Table 8	Drive Performance Specifications.....	43
Table 9	Environmental Requirements.....	44
Table 10	Reliability.....	46
Table 11	Environmental Tolerances	47

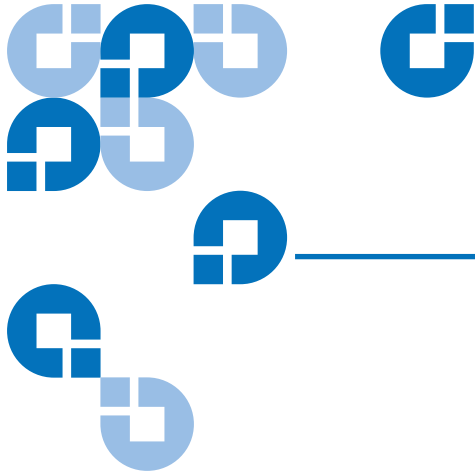

Preface

The LTO-3 Tape Drive is a high-performance 16-channel tape drive that complies with the LTO interchange specifications. The drive is suited for mid-range to high-end servers, mainframe systems, and tape library automation systems.

Audience

This document was written for users of the LTO-3 Tape Drive.

Purpose

This document provides information about the LTO-3 Tape Drive including:

- Installation
- Unpacking
- Basic library operations
- Specifications
- UNIX Settings
- Troubleshooting

Document Organization

This User's Guide describes how to install, configure, and care for the LTO-3 desktop and internal tape drives. Please read the appropriate chapters and appendixes carefully, and keep this Guide handy for future reference.

- [Chapter 1, Overview, Unpacking Instructions and Quick Start](#) provides an overview of LTO-3 Tape Drive and its features as well as handling precautions and unpacking tips. It provides quick-start instructions for getting the drives up and running in the shortest possible time.
- [Chapter 2, Installation](#) provides installation instructions for the internal and desktop drives. It provides a summary of cabling and connector specifications.
- [Chapter 3, Operation](#) explains the use and operation of the drive and describes maintenance procedures, including drive "parking."
- [Chapter 4, Theory](#) describes the theory of operation behind the drives, including the technology used in various drive components.
- [Chapter 5, Specifications](#) contains detailed drive and cartridge specifications, as well as a summary of regulatory approvals and WEEE Compliance statement.
- [Chapter 6, UNIX Settings](#) describes the settings for Unix systems.
- [Chapter 7, Troubleshooting Guide](#) provides troubleshooting procedures you can follow in the unlikely event you encounter a problem with your drive.

This document concludes with a detailed index.

Notational Conventions

This manual uses the following conventions:

Note: Notes emphasize important information related to the main topic.

Tech Tip: Tech Tips provide technical information which may be helpful in performing the procedure.

Caution: Cautions indicate potential hazards to equipment and are included to prevent damage to equipment.

Warning: Warnings indicate potential hazards to personal safety and are included to prevent injury.

Related Documents

Refer to the appropriate product manuals for information about your tape drive and cartridges.

SCSI-2 Specification

The SCSI-2 communications specification is the proposed American National Standard for information systems, dated March 9, 1990. Copies may be obtained from:

Global Engineering Documents
15 Inverness Way, East
Englewood, CO 80112
(800) 854-7179 or (303) 397-2740

Contacts

Quantum company contacts are listed below.

Quantum Corporate Headquarters

To order documentation on the LTO-3 Tape Drive or other products contact:

Quantum Corporation
P.O. Box 57100
Irvine, CA 92619-7100
(949) 856-7800
(800) 284-5101

Technical Publications

To comment on existing documentation send e-mail to:

doc-comments@quantum.com

Quantum Home Page

Visit the Quantum home page at:

www.quantum.com

Customer Support

The Quantum Customer Support Department provides a 24-hour help desk that can be reached at:

North/South America:	(949) 725-2100 or (800) 284-5101
Asia/Pacific Rim:	(International Code) + 61 7 3839 0988
Europe/Middle East/Africa:	(International Code) + 44 (0) 1256 848748

Send faxes for the Customer Support Department to:

North/South America:	(949) 725-2176
Asia/Pacific Rim:	(International Code) + 61 7 3839 0955
Europe/Middle East/Africa:	(International Code) + 44 (0) 1256 848777

Send e-mail for the Customer Support Department to:

Asia/Pacific Rim:	apachelp@quantum.com
Europe/Middle East/Africa:	eurohelp@quantum.com

Visit our web site:

www.quantum.com/support

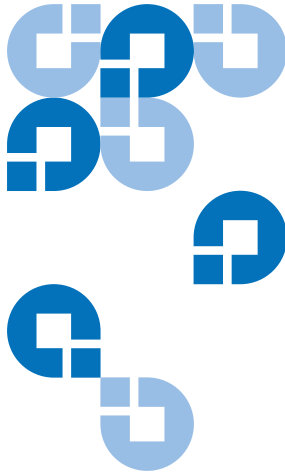

Chapter 1 Overview, Unpacking Instructions and Quick Start

This chapter provides an overview of this product and a quick start guide. It also discusses unpacking and inspection considerations.

Topics covered in this chapter are:

- [Overview](#)
- [Internal Tape Drive Guidelines and Cautions](#)
- [Quick Start Guide](#)
- [Internal Tape Drive Guidelines and Cautions](#)

Overview

The LTO-3 is a high-performance 16-channel tape drive that complies with the LTO interchange specifications. The drive is suited for mid-range to high-end servers, mainframe systems, and tape library automation systems.

The LTO-3 Tape Drive uses Ultrium data cartridges. Its capacity is maximized using intelligent data compression. The drive has a native capacity of 400 Gbytes (800 Gbytes assuming 2:1 data compression).

Drive Configurations

The LTO-3 Tape Drive has a 5¼-inch, full-height form factor, with automatic electromechanical cartridge soft load. The drive is available as an internal and a desktop drive.

- Internal LTO-3 Tape Drive fits in a 5¼-inch full-height drive bay.
- Desktop LTO-3 Tape Drive is a stand-alone unit with a built-in power supply.

Figure 1 Typical Internal and Desktop Configurations

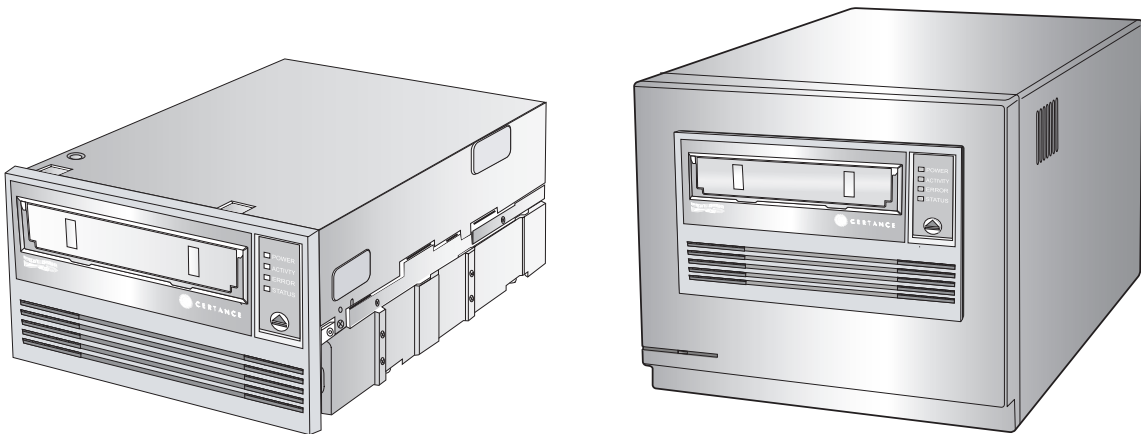

Features

The following list summarizes the key features of the LTO-3 Tape Drive.

- Performance
 - Up to 68 Mbytes-per-second native transfer.
- 13-Speed Transfer matches tape drive speed to that of the host – optimizes data transfers, resulting in shorter backup times and increased reliability.
- Two convenient form-factors:
 - 5¼-inch internal form-factor for installation in a 5¼-inch half-height space.
 - External desktop form-factor.

- Intelligent data compression maximizes performance and capacity by analyzing compressibility prior to recording.
- Cartridge memory enables fast loading of cartridges and stores pertinent information about the media.
- 128-Mbyte data buffer for high-performance.
- Tape Alert drive performance monitoring and reporting.
- Third generation read channel for increased maturity and data integrity.
- Patented head positioner for increased data integrity.
- Shock damped isolated chassis.
- MediaShield increases media life through managed airflow dynamics with isolated HTI chamber.
- SmartVerify includes two levels of ECC for extra data safety and protection from errors.
- Reliable tape picking implementation for increased reliability.
- Custom-designed LSI circuitry for fast, efficient data processing.
- RISC processors for fast, efficient data processing.
- Supports a wide variety of UNIX platforms

Unpacking and Inspection

Although drives are inspected and carefully packaged at the factory, damage may occur during shipping. Follow these steps for unpacking the drive.

- 1** Visually inspect the shipping containers and notify your carrier immediately of any damage.
- 2** Place shipping containers on a flat, clean, stable surface; then carefully remove the contents. If the equipment is damaged, notify your Quantum representative.
- 3** Always save the containers and packing materials for any future reshipment.

Quick Start Guide

Use the following quick-start instructions to get your tape drive up and running as quickly as possible.

Internal LTO-3 Tape Drive Quick Start

Use the following procedure to install the internal LTO-3 Tape Drive. Print the page and check each step as you complete it. If you need more information about a step, turn to the section referenced in the step.

<input type="checkbox"/>	1	Unpack the contents of your drive package, and check for damaged items. See Internal Tape Drive Guidelines and Cautions on page 5.
<input type="checkbox"/>	2	Review the drive's default settings and change them if necessary: <ul style="list-style-type: none">• SCSI ID: 6• Terminator Power: Disabled See Configuring an LVD Drive on page 8.
<input type="checkbox"/>	3	Turn off your computer, remove its covers and power cable, and select a mounting bay for the drive. See Mounting the Internal LTO-3 Tape Drive on page 11.
<input type="checkbox"/>	4	Connect a SCSI interface cable to the drive. See Connecting a SCSI Cable on page 14.
<input type="checkbox"/>	5	Terminate the SCSI bus if the internal tape drive is the last device on the SCSI bus. See Checking the SCSI Termination on page 15.
<input type="checkbox"/>	6	Connect a serial cable, if connecting the tape drive to a tape library. See Connecting a Serial Cable for Tape Libraries on page 16.
<input type="checkbox"/>	7	Connect a power cable to the drive. See Bus Composition on page 17.
<input type="checkbox"/>	8	Replace the computer covers and power cable, turn on the computer, and verify that the internal tape drive is operating properly.
<input type="checkbox"/>	9	Register your tape drive. See Registering Your Tape Drive on page 18.

**Desktop LTO-3
Tape Drive Quick
Start**

Use the following procedure to install the desktop LTO-3 Tape Drive. Print the page and check each step as you complete it. If you need more information about a step, turn to the section referenced in the step.

<input type="checkbox"/>	1	Unpack the contents of your drive package, and check for damaged items. See Internal Tape Drive Guidelines and Cautions on page 5.
<input type="checkbox"/>	2	Review the drive's default settings and change them if necessary: <ul style="list-style-type: none">• SCSI ID: 6 See Setting the SCSI ID on page 19.
<input type="checkbox"/>	3	Connect a SCSI interface cable to the drive. See Connecting a SCSI Cable on page 19.
<input type="checkbox"/>	4	Check the SCSI termination. See Checking the SCSI Termination on page 20.
<input type="checkbox"/>	5	Connect a power cable to the drive. See Connecting a Power Cord on page 21.
<input type="checkbox"/>	6	Turn on the computer, turn on the desktop tape drive, and verify that the desktop tape drive is operating properly.
<input type="checkbox"/>	7	Register your tape drive. See Registering Your Tape Drive on page 21.

Internal Tape Drive Guidelines and Cautions

The following guidelines and cautions apply to handling and installing internal tape drives. Keep them in mind as you install the drive.

- Handle the drive by the sides rather than by the top cover to reduce the risk of dropping the drive or damaging it during installation.
- Internal drives contain some exposed components that are sensitive to static electricity. To reduce possible damage from static discharge, the drives are shipped in a protective antistatic bag. Do not remove the drive from the antistatic bag until you are ready to install it.

- Before you remove the drive from the antistatic bag, touch a metal or grounded surface to discharge any static electricity buildup from your body.
- Always lay the drive either on top of the antistatic bag or place it inside of the bag to reduce possible damage from static discharge.
- Install LVD drives only in an LVD environment. Do not mix HVD and LVD devices on the same SCSI bus.
- Due to the speed of the LTO-3 Tape Drive, it is recommended that a maximum of one LTO-3 Tape Drive be connected to one host SCSI adapter.

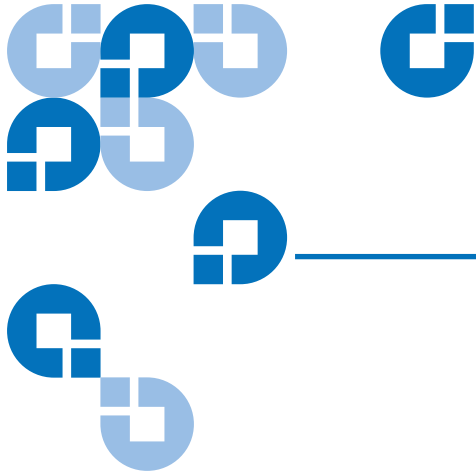

Chapter 2 Installation

This chapter explains how to install the internal and desktop LTO-3 Tape Drives.

Topics covered in this chapter are:

- [Installing an Internal LTO-3 Tape Drive](#)
- [Installing a Desktop LTO-3 Tape Drive](#)

Drive Installation Instructions

After unpacking and inspecting your shipping containers and reviewing the installation guidelines and cautions, proceed to the appropriate section in this chapter for instructions on installing your LTO-3 Tape Drive.

- [Installing an Internal LTO-3 Tape Drive.](#)
- [Installing a Desktop LTO-3 Tape Drive](#) on page 18.

Installing an Internal LTO-3 Tape Drive

Installing an internal LTO-3 Tape Drive with an Ultra 160 SCSI LVD interface involves the following steps:

- 1 [Configuring an LVD Drive](#)
- 2 [Mounting the Internal LTO-3 Tape Drive](#) on page 11
- 3 [Connecting a SCSI Cable](#) on page 14
- 4 [Checking the SCSI Termination](#) on page 15
- 5 [Connecting a Serial Cable for Tape Libraries](#) on page 16
- 6 [Bus Composition](#) on page 17
- 7 [Registering Your Tape Drive](#) on page 18

Configuring an LVD Drive

Before you install the LVD tape drive in your computer, you may need to configure the drive's SCSI ID and terminator power features. The default configuration settings for the LTO-3 Tape Drive is:

- SCSI ID: 6
- Terminator power: disabled

If you need to change these settings, refer to the following sections. Otherwise, proceed to [Mounting the Internal LTO-3 Tape Drive](#).

SCSI ID

Jumper Pins: 1–2, 3–4, 5–6, 7–8

Default Setting: SCSI ID 6

Each SCSI device on the bus must have its own unique SCSI ID. The internal tape drive is shipped with a default SCSI ID of 6. If another SCSI device in the SCSI chain is using this ID, use jumper pins 1–2, 3–4, 5–6,

and 7-8 to change the SCSI ID of the LTO-3 Tape Drive (see [table 1](#) and [table 2](#)), or assign a unique SCSI ID to the other SCSI device.

Note: The SCSI controller or host adapter generally uses ID 7. In some systems, the boot drive uses ID 0 or ID 1. Avoid setting your drive's SCSI ID to these settings.

Figure 2 Internal LTO-3 Tape Drive Jumper Settings

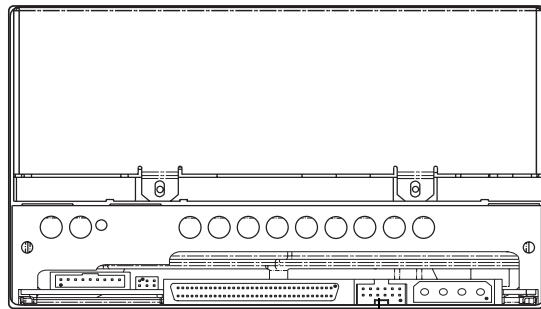

Drive Configuration Jumpers Pins

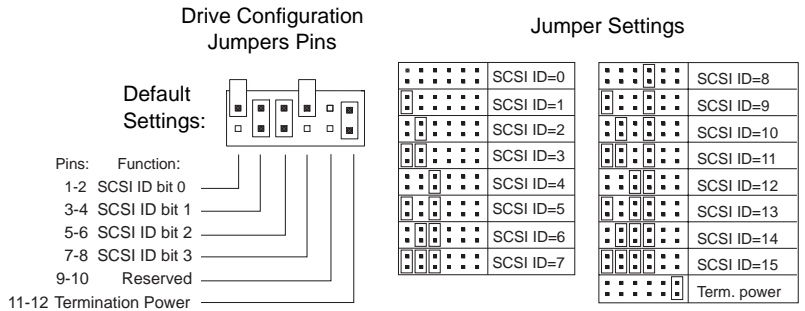

Table 1 ISCSI IDs and Jumper Settings for an Internal LTO-3 Tape Drive

SCSI ID	Jumpers			
	1-2	3-4	5-6	7-8
0	Open	Open	Open	Open
1	Shunted	Open	Open	Open

SCSI ID	Jumpers			
	1-2	3-4	5-6	7-8
2	Open	Shunted	Open	Open
3	Shunted	Shunted	Open	Open
4	Open	Open	Shunted	Open
5	Shunted	Open	Shunted	Open
6 (default)	Open	Shunted	Shunted	Open
8	Open	Open	Open	Shunted
9	Shunted	Open	Open	Shunted
10	Open	Shunted	Open	Shunted
11	Shunted	Shunted	Open	Shunted
12	Open	Open	Shunted	Shunted
13	Shunted	Open	Shunted	Shunted
14	Open	Shunted	Shunted	Shunted
15	Shunted	Shunted	Shunted	Shunted

Terminator Power

By default, terminator power is disabled on the internal LTO-3 Tape Drive. To enable terminator power, place a jumper across pins 11 and 12.

Note: The internal LTO-3 Tape Drive does not provide SCSI termination. Thus, a terminator must be installed on the drive if it is the last device in a SCSI chain.

Mounting the Internal LTO-3 Tape Drive

You can mount the internal LTO-3 Tape Drive either horizontally or vertically, with the drive's left side facing up (see [figure 3](#)).

If you mount the drive:

- Vertically the left side of the drive must face up and the side of the drive should be within 5 degrees of horizontal.
- Horizontally, the base of the drive must be within 15 degrees of horizontal and the drive must not be upside down.

Figure 3 Acceptable
Mounting Orientations

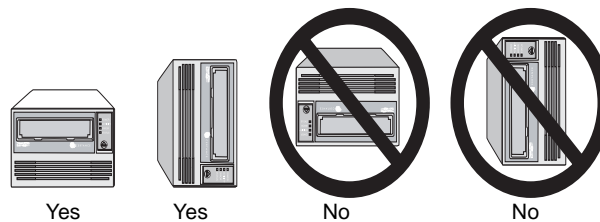

Mount the drive in a 5.25-inch, full-height drive bay and secure it using two M3.0 X 5 metric screws on each side of the drive. Do not use screws longer than 5 mm or you may damage the drive. [Figure 4](#) shows the locations of the mounting-screw holes on the side and bottom of the drive, respectively.

Figure 4 Internal
LTO-3 Tape Drive
Mounting Dimensions

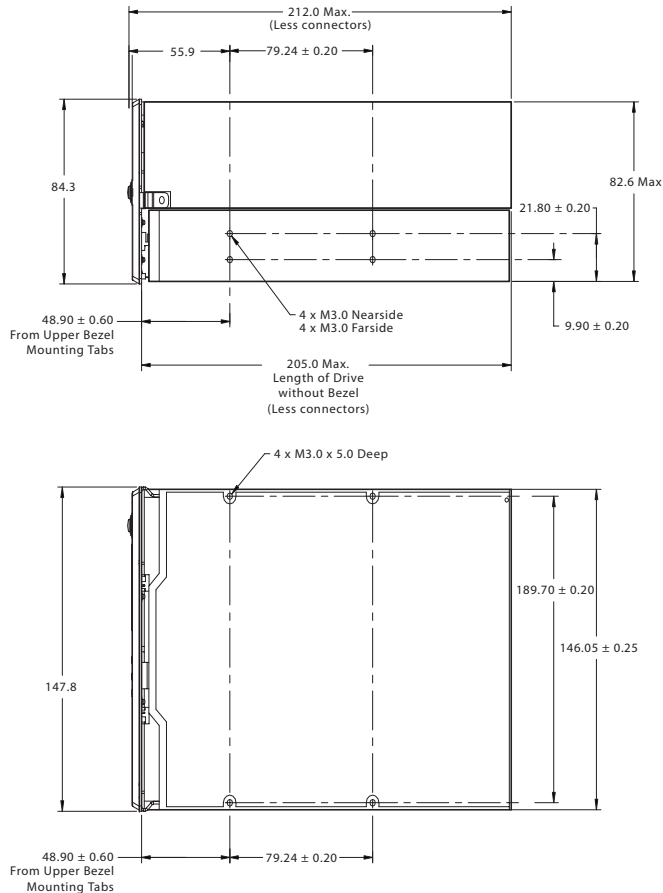

Connector Detail

Two connectors are specified, a fixed board connector and a free cable connector.

ADI Fixed Board Connector

The fixed board connector (see [figure 5](#)) is intended to be attached to a circuit board in a removable medium device. It may also be used in the automation device containing the removable medium device. The attachment of the connector to the circuit board that is, surface mount or through-hole) is beyond the scope of this standard. The location of the

connector in a removable medium or automation device is beyond the scope of this standard.

Figure 5 ADI Fixed Board Connector

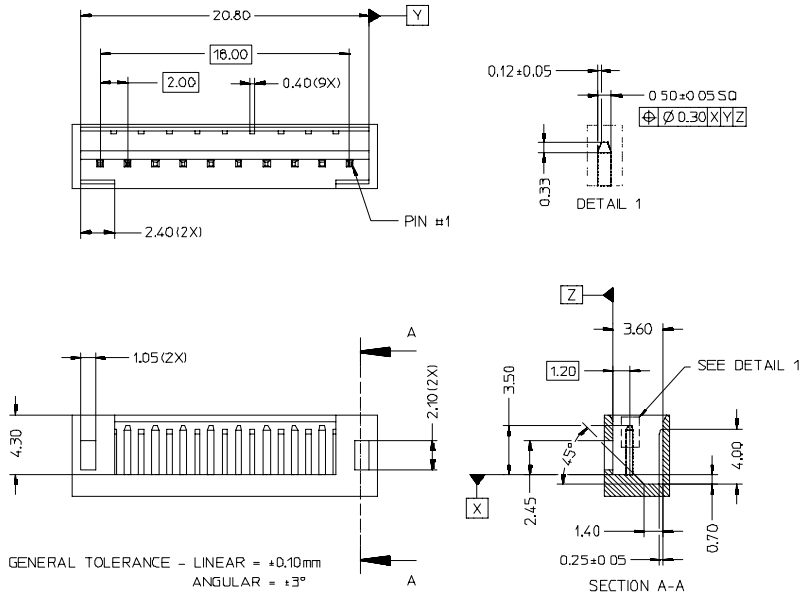

ADI Free Cable Connector

The free cable connector is intended to mate with the fixed board connector (see [figure 6](#)).

Figure 6 ADI Free
Cable Connector

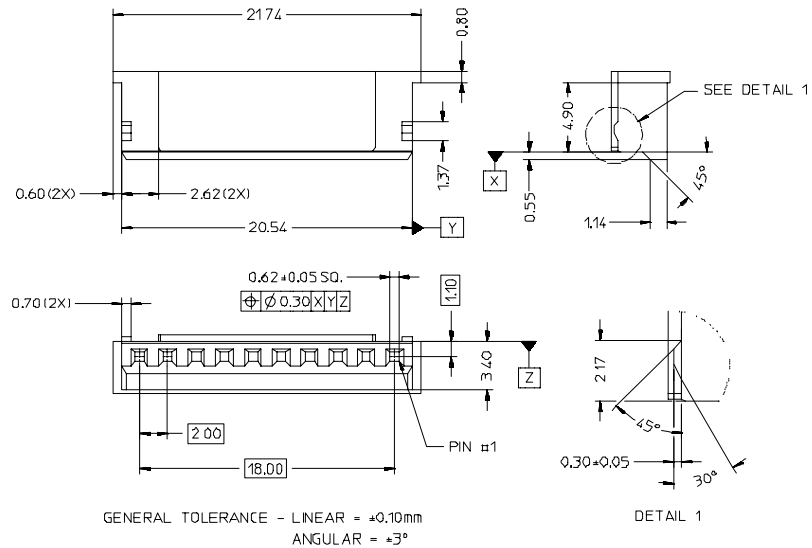

When the ADI free cable connector is used on both ends of a cable, like-numbered pins shall be connected together, that is, pin 1 on end A is wired to pin 1 on end B, pin 2 on end A to pin 2 on end B, and so forth.

Connecting a SCSI Cable

The internal LTO-3 Tape Drive has an Ultra 160 SCSI interface, terminated by a 68-pin LVD SCSI connector. Use the following procedure to connect a SCSI cable to this connector.

- 1 Turn off all power to the drive and the computer.
- 2 Attach the SCSI interface cable to the 68-pin SCSI interface connector on the back of the drive (see [figure 7](#)).

Figure 7 Rear View of
the Internal LTO-3
Tape drive

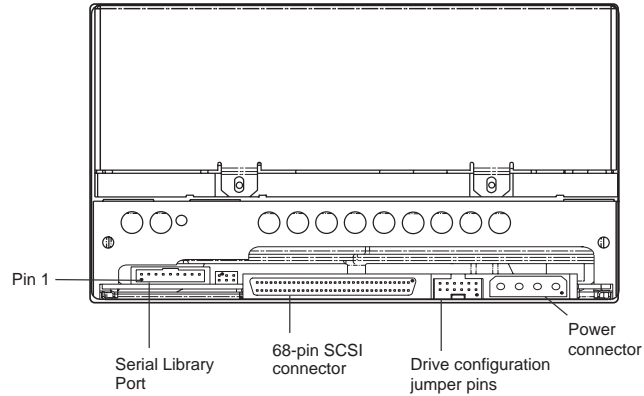

Caution: Install an LVD drive only in an LVD environment.

Checking the SCSI Termination

The Internal LTO-3 Tape Drive does not provide SCSI termination. You must place a SCSI bus terminator or a SCSI device with termination enabled at the end of the SCSI chain. Two examples of SCSI termination are shown in [figure 8](#).

The Internal LTO-3 Tape Drive provides terminator power if a jumper is placed on the termination power jumper pins (see [Terminator Power](#)).

Figure 8 Two SCSI Termination Examples for the Internal LTO-3 Tape Drive

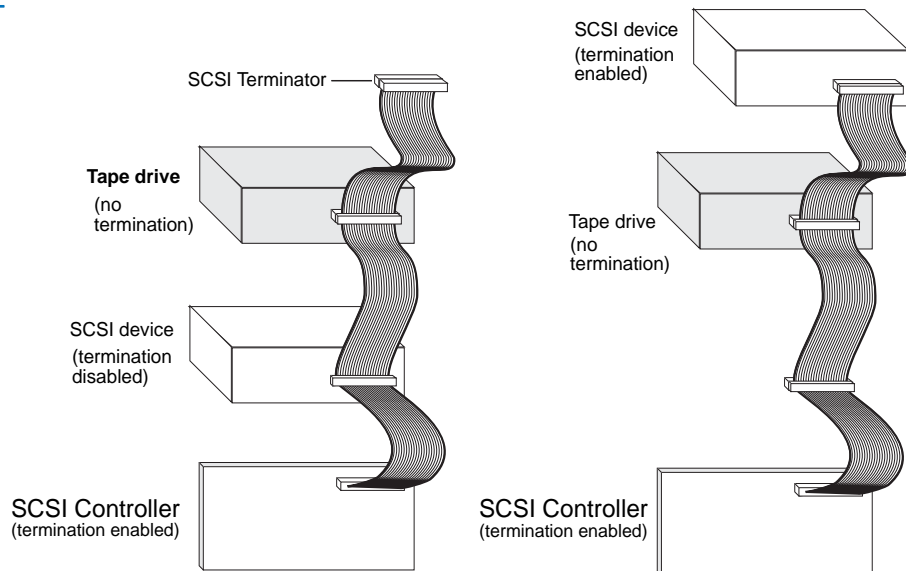

Connecting a Serial Cable for Tape Libraries

The internal LTO-3 Tape Drive includes an RS-422 serial interface for tape libraries. This connector is an in-line shrouded and keyed 10-pin 2 mm connector. It is located on the lower left side of the back of the drive (see [figure 7](#)). [Table 2](#) shows the pin descriptions for the serial interface connector.

Table 2 Serial Interface Connector Pin Assignments (LTO-3)

Pin Number	Description	Pin Number	Description
1	+Tx _a - Rx _d	6	Sense _d
2	-Tx _a - Rx _d	7	Sense _a
3	Ground	8	Reset _a
4	-Tx _d - Rx _a	9	Signal _{aux}
5	+Tx _d - Rx _a	10	Sense _{aux}

Bus Composition

[Table 3](#) defines the connections that make up the ADT bus. With the exception of Sense_a and Sense_d this standard defines the behavior of these connections only when an initiator port asserts Sense_a and the target port asserts Sense_d.

Table 3 ADT Bus Connections

Connection Name	O/M	Connection Type	Driven By	Connection Definition
Reset _a	O	Signal	automation port	An automation device may use this connection to signal a reset request to a data transfer device. A data transfer device shall treat the receipt of a signal on this connection as a port logout
Sense _a	M	Sense	automation port	A data transfer device shall use this connection to sense the presence or absence of an automation device on the ADT bus.
Sense _{aux}	O	Sense		A vendor unique sense connection. This standard does not define the use of this connection.
Sense _d	M	Sense	DTD port	An automation device shall use this connection to sense the presence or absence of a data transfer device on the ADT bus.
Signal _{aux}	O	Signal		A vendor unique signal connection. This standard does not define the use of this connection.
Tx _a - Rx _d	M	Tx-Rx	automation port	An automation device shall use this connection to send serialized data. A data transfer device shall receive serialized data on this connection.
Tx _d - Rx _a	M	Tx-Rx	DTD port	A data transfer device shall use this connection to send serialized data. An automation device shall receive serialized data on this connection.

Connecting a Power Cable

Attach a four-pin power cable to the power connector on the back of the drive. [Figure 7](#) shows the location of the power connector.

The recommended 4-pin power connector for internal drives is an AMP 1-48024-0 housing with AMP 60617-1 pins or equivalent.

Installing the LTO Driver

If you intend to use your drive with the Microsoft native backup applet on Windows Server 2003, Windows XP, or Microsoft Windows 2000 operating system, install the appropriate LTO driver. See the Resource CD. **This driver is not necessary with commercial backup application software.**

Registering Your Tape Drive

After you install the internal tape drive, be sure to register it. Registering your drive ensures that you will receive the latest information about your drive, as well as other product, service, and support information. For your convenience, you can register your drive through our Web site at www.quantum.com/registration.

Installing a Desktop LTO-3 Tape Drive

The desktop LTO-3 Tape Drive is a compact subsystem that connects to the host computer through a SCSI port. Installing a desktop drive involves the following steps:

- 1 [Setting the SCSI ID](#)
- 2 [Connecting a SCSI Cable](#)
- 3 [Checking the SCSI Termination](#)
- 4 [Connecting a Power Cord](#)
- 5 [Registering Your Tape Drive](#)

Setting the SCSI ID

Each SCSI device on the bus must have its own unique SCSI ID. The desktop tape drive is shipped with a default SCSI ID of 6. Avoid setting drive ID to 7. If another SCSI device in the SCSI chain is already using this ID, either use the push-button switch on the back of the drive to change the drive's SCSI ID (see [figure 9](#)) or assign a unique SCSI ID to the other SCSI device.

If you change the SCSI ID on the tape drive, turn off the tape drive before changing the SCSI ID. The change takes effect when you turn on the drive.

Note: The SCSI controller or host adapter generally uses ID 7. In some systems, the boot drive uses ID 0 or ID 1. Avoid setting your drive's SCSI ID to these settings.

Figure 9 Switches and Connectors on the Back of the Desktop LTO-3 Tape Drive

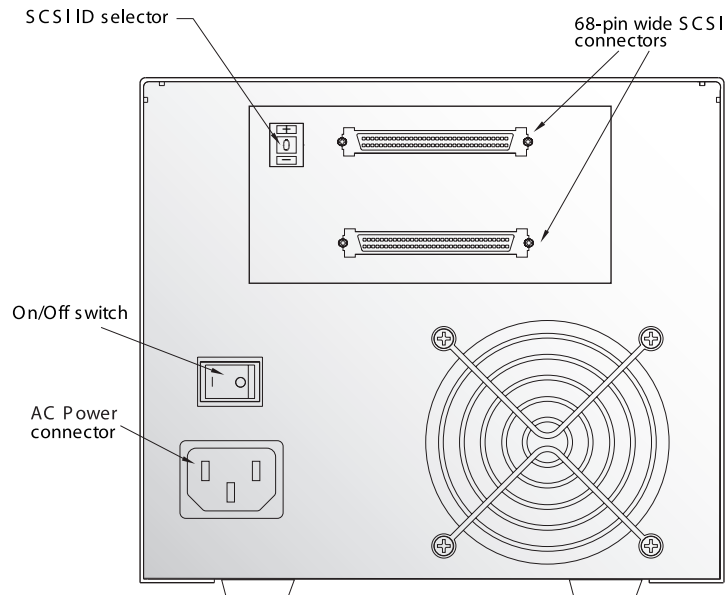

Connecting a SCSI Cable

The desktop LTO-3 Tape Drive has two 68-pin, shielded SCSI interface connectors (ANSI Alternative 2) on the rear panel (see [figure 9](#)). These connectors consist of two rows of ribbon contacts spaced 2.16 mm (0.085 in) apart. Either connector can be used as a SCSI IN or SCSI OUT

connection. This means you can use either connector to attach the drive to a host computer or to another SCSI device.

- 1 Turn off all power to the drive and the computer.
- 2 Attach the SCSI interface cable to one of the 68-pin SCSI interface connectors on the back of the drive (see [figure 9](#)).

Checking the SCSI Termination

If the desktop LTO-3 Tape Drive is the last or only device in a SCSI chain, install a terminating plug on the unused SCSI connector. See [figure 10](#) for two SCSI termination examples.

Note: Termination power is enabled as a default for desktop drives.

Figure 10 SCSI Termination Examples for the Desktop LTO-3 Tape Drive

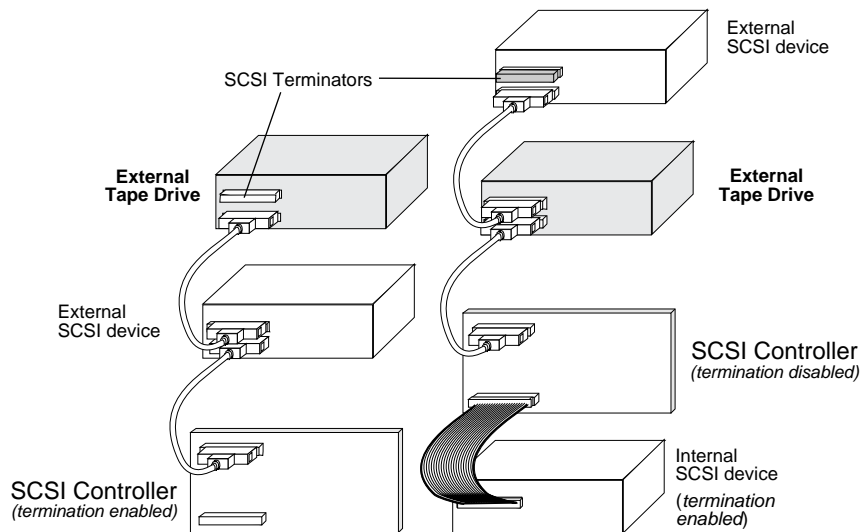

Example 1: SCSI termination in a system that has only external SCSI devices.

Example 2: SCSI termination in a system that has both internal and external SCSI devices.

Connecting a Power Cord

Attach the power cord securely to the power connector on the back of the desktop LTO-3 Tape Drive (see [figure 9](#)).

Installing the LTO Driver

If you intend to use your drive with either the Microsoft Windows Server 2003, Windows XP, or Microsoft Windows 2000 operating system, install the LTO driver. See the Resource CD. **This driver is not necessary with commercial backup application software.**

Registering Your Tape Drive

After you install the desktop tape drive, be sure to register it. Registering your drive ensures that you will receive the latest information about your drive, as well as other product, service, and support information. For your convenience, you can register your drive through our Web site at www.quantum.com/registration.

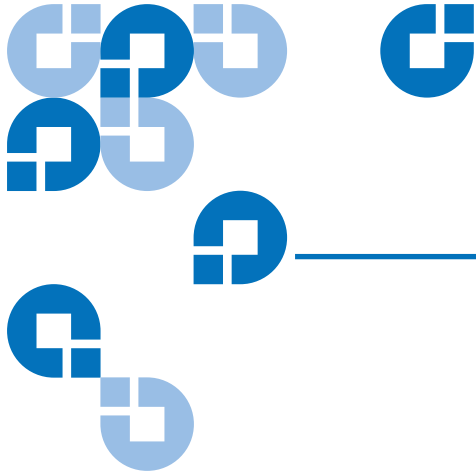

Chapter 3 Operation

This chapter describes how to operate the LTO-3 Tape Drive. Topics covered in this chapter are:

- [Understanding the Front Panel Display](#)
- [Blink Codes](#)
- [Using LTO Cartridges](#)
- [Drive Maintenance](#)
- [Parking the Drive for Shipping](#)

Understanding the Front Panel Display

[Figure 11](#) shows a view of the LTO-3 front-panel display.

Figure 11 Generic
Front Panel Display

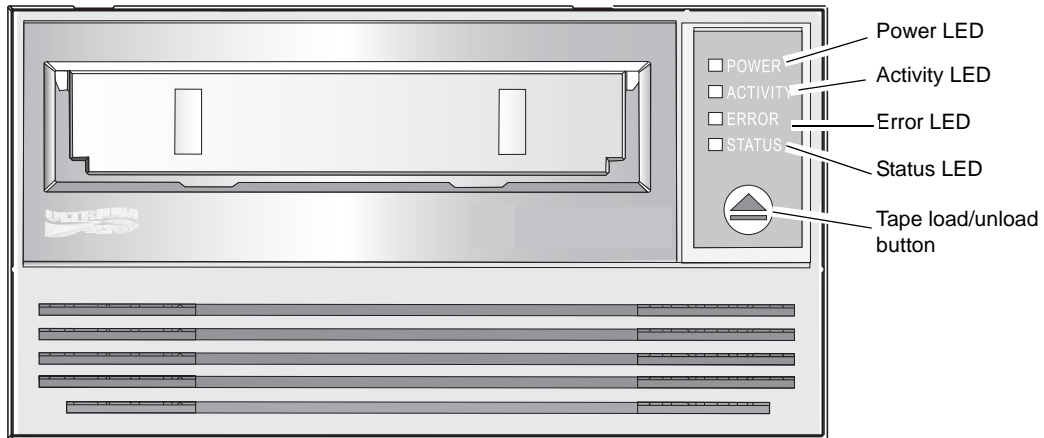

The LTO-3 Tape Drive has four LEDs on the front panel. The LED colors and functions are summarized below.

- **Power LED** (green)
- **Activity LED** (green)
- **Error LED** (orange)
- **Status LED** (amber)

The **Activity**, **Error**, and **Status LEDs** blink or go on to indicate information about the tape drive. For more information about the **blink codes** associated with these LEDs, see [Blink Codes](#).

Blink Codes

[Table 4](#) summarizes the blink codes for the LTO-3 Tape Drive.

Table 4 LTO-3 Tape
Drive Blink Codes

Drive Condition	Activity LED (Green)	Error LED (Orange)	Status LED (Amber)
Cleaning Request			ON
Hardware error		Fast	
Positioning - loading, unloading, rewinding, spacing, or locating	Slow		
Tape Active - writing, reading, or verifying	Slow		
Manual intervention required		ON	
Power-On-Self-Test (POST) failure		Fast	ON
Cleaning cartridge present	ON		ON
Cleaning cartridge at EOT	ON		Fast
Servo initialization	Slow		Slow
Power-On-Self-Test (POST) in progress	Slow	Slow	Slow
Cleaning failure or media error		Fast	Fast
Microcode download	Fast	Slow	Fast

Drive Condition	Activity LED (Green)	Error LED (Orange)	Status LED (Amber)
Microcode download error	Fast	Fast	Fast

Note: **ON** refers to a constant light;
Slow refers to a blink rate of 1/2 second on, 1/2 second off;
Fast refers to a blink rate of 1/8 second on, 1/8 second off.

Using LTO Cartridges

Loading a Cartridge

To load an Ultrium cartridge into the LTO-3 Tape Drive:

- Place the cartridge in the slot and gently push until the cartridge is sensed and automatically retracted into the drive.
- If the cartridge is already in the slot from a previous ejection, gently extract the cartridge partially and then gently push in until the cartridge is sensed and automatically retracted into the drive.
- If the cartridge is already in the slot from a previous ejection, a SCSI command or Library command can be issued to automatically retract the cartridge into the drive.
- If the cartridge is already in the slot from a previous ejection, the **Load/Unload** button can be depressed to automatically retract the cartridge into the drive.

Unloading a Cartridge

To unload an Ultrium cartridge from the LTO-3 Tape Drive, either:

- Use a library or host command to unload the tape, or
- Push the **Load/Unload** button on the front of the drive.

Caution: Several seconds may elapse between the time you press the **Load/Unload** button and the time the cartridge is ejected. Do not power down the tape drive or the host computer until the drive has completely ejected the cartridge.

Write-protecting a Cartridge

Ultrium cartridges have a sliding write-protect switch near the back right corner of the cartridge, see [figure 12](#).

- If you slide the switch to the position farthest from the corner of the cartridge, data can be read from the cartridge but not written to it.
- If you slide the switch all the way toward the corner, see [figure 12](#), data can be read from and written to the cartridge.

Note: LTO cartridges have prewritten servo patterns and should not be bulk erased.

Figure 12 Ultrium Cartridge Showing Write-Protect Switch

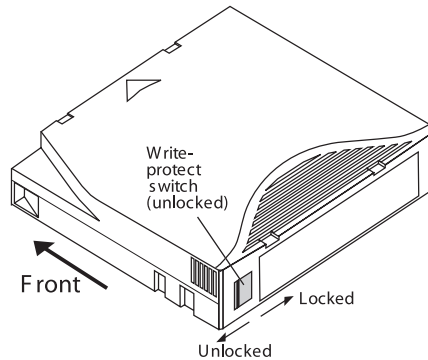

Cartridge Care and Maintenance

To protect the data on your Ultrium data cartridges, observe the following precautions:

- Always remove the cartridge from the drive when not in use and store it in its protective case.
- Do not expose cartridges to dirt, dust, or moisture.
- Do not touch the tape media within a cartridge.
- Do not use data cartridges outside the specified operating conditions: 10° C to 40° C, 20% to 80% relative humidity.

If a data cartridge has been exposed to temperature or humidity changes within the limits listed above, allow the tape cartridge to acclimate to its surroundings for at least one hour before use.

If, during storage and/or transportation, a data cartridge has been exposed to conditions outside the above range, it must be conditioned before use in the operating environment. The conditioning process requires exposure to the operating environment for a time equal to, or greater than, the time away from the operating environment, up to a maximum of 24 hours.

- Keep the cartridge away from direct sunlight and heat sources, such as radiators, heaters or warm air ducts.
- Keep the cartridge away from sources of electromagnetic fields, such as telephones, computer monitors, dictation equipment, mechanical or printing calculators, motors, magnetic tools, and bulk erasers.
- Avoid dropping the cartridges. This can damage components inside the cartridge, possibly rendering the tape unusable. If a tape is dropped it is advisable to open the cartridge door and make sure that the leader pin is in the correct position. A dropped cartridge should be retensioned before use.
- Do not bulk erase Ultrium cartridges. Bulk-erased cartridges cannot be reformatted by the tape drive and will be rendered unusable.

Drive Maintenance

The Ultrium drive requires little or no maintenance. However, the drive mechanism may need to be cleaned.

Cleaning the Tape Drive

Excessive tape debris or other material may accumulate on the tape heads if the drive is used with non-approved media or operated in a hot, dusty environment. In this case, the drive may experience excessive errors while reading or writing, and the amber **Status** LED remains on continuously during operation. This means that the drive heads need to be cleaned.

The LTO cleaning cartridge has the same dimensions as the data cartridge and contains an LTO-CM (Cartridge Memory), but is loaded with cleaning media instead of recording media. Always keep the cleaning cartridge in its protective case when not in use.

To clean the drive, insert an LTO Ultrium cleaning cartridge. During the cleaning process, both the **Status** and **Drive** LEDs remain lit. After the cleaning process is completed, the cartridge may be ejected automatically, or you may need to press the load/unload button to remove the cartridge, depending on the drive configuration. Each time you use the cleaning cartridge, write the date on the label for future reference.

Note: If the **Status** LED comes on continuously within 24 hours after a cleaning cycle, perform the cleaning cycle again. If, after three cleaning cycles in a 72-hour period, the **Status** LED lights up again, contact Customer Support.

Each time the drive is cleaned, the tape advances to a new, unused section of media. After approximately 50 cleanings, all of the media will be used up and you should discard the cleaning cartridge. When a cleaning cartridge is used up, the amber **Status** LED flashes, while the green **Drive** LED remains on. Do not reuse a spent cleaning cartridge.

Note: The cleaning procedure will not run and the cleaning cartridge will be ejected in the following circumstances:

- The drive does not recognize the cartridge as an LTO cleaning cartridge.
- All of the tape on the cleaning cartridge has been used up (at EOT). In this case, the **Status** LED will flash rapidly while the **Drive** LED remains on.

Parking the Drive for Shipping

Quantum recommends that you “park” the LTO-3 Tape Drive before shipping it or placing it in an environment where they may be subject to physical shock. Parking the drive moves the tape mechanism to the configuration that is resilient to shock. You can park the LTO-3 Tape Drive using the **Load/Unload** button on the front of the drive, or by running special software on your host system. In either case, the drive must be powered up to enter park mode.

Using the Load/Unload Button to Park the Drive

To park the drive manually, press and hold the **Load/Unload** button for 15 seconds or more. After you release the **Load/Unload** button, the green **Drive** LED lights up and the parking process begins. During the parking process, the picker arm moves into the take-up reel.

When the process is complete, the **Drive** LED goes off, indicating that the drive has been successfully parked.

After parking the drive, you can turn off the drive and pack it for shipping. When you turn the drive on again, it automatically returns to normal operating mode.

If you need to unpark the drive without cycling power, press and hold the **Load/Unload** button for more than 5 seconds, but less than 15 seconds.

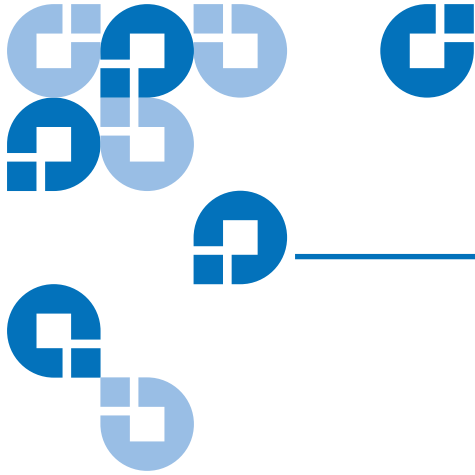

This chapter describes operational theories used in the LTO-3 Tape Drive.

The topics covered in this chapter are:

- [Track Layout](#)
- [Recording Method](#)
- [Data Buffer](#)
- [Data Integrity](#)
- [Data Compression](#)

Track Layout

With the LTO-3 Tape Drive, there are 704 data tracks on the LTO tape, numbered 0 through 703. Data track 703 is the track closest to the bottom edge of the tape (the reference edge).

The area between adjacent servo bands is a data band. There are 4 data bands, each of which includes 176 data tracks. The data bands are numbered 2,0,1,3. Data band 2 is closest to the bottom edge of the tape.

A track group is a set of tracks that is recorded concurrently. The sets of 11 data tracks in a data band are data sub bands. There are 16 data sub bands per data band. The data tracks are accessed in a serpentine manner.

A wrap is a track group recorded in the physical forward or physical reverse direction. The wraps are recorded in a serpentine fashion starting in data band 0. The tape contains 44 track groups, 22 written in the forward direction and 22 written in the reverse direction. Even-numbered wraps are recorded in the forward direction (BOT to EOT), and odd-numbered wraps are recorded in the reverse direction (EOT to BOT).

[Figure 13](#) shows the layout of data on an LTO tape.

Figure 13 Layout of the Tracks on LTO Ultrium Tapes

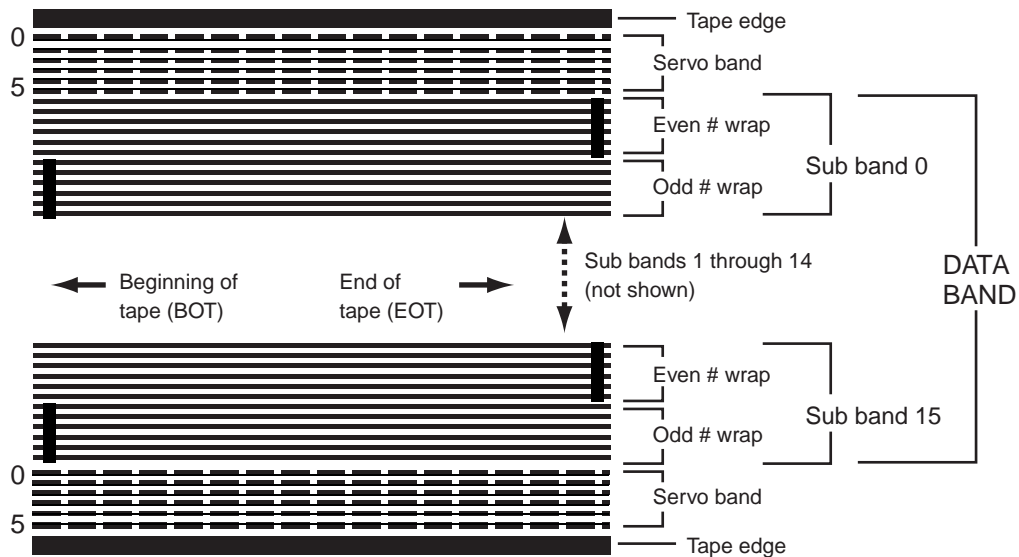

Recording Method

The LTO-3 Tape Drive records data using write-equalized (0,13/11) Run Length Limited (RLL) code. RLL (0,13/11) Data bits are defined as follows:

- **ONE** is represented by a flux transition at the center of a bit-cell.
- **ZERO** is represented by no flux transition in the bit-cell.

Data Buffer

In its default configuration, the LTO-3 Tape Drive has a 128-Mbyte buffer. The buffer controller has a burst transfer rate of 320 Mbytes/sec, and utilizes bank switching to achieve a maximum average bandwidth of nearly 240 Mbytes/sec. The high bandwidth is needed to support look-aside data compression in the case of compressible data being transferred from SCSI at 160 Mbytes/sec.

Data Integrity

The mechanical and electrical design of the drives ensures that drive performance does not degrade over a drive's operating life. Changes in head alignment, head wear, component drift, and other factors are minimized to ensure that data integrity and interchange capability are not compromised over the drive's operating life. In addition, the drive incorporates adaptive FIR filters that are capable of modifying the equalization of each read channel dynamically to compensate for many of those changes.

The error rate of the LTO-3 Tape Drive is less than 1 hard error in 10^{17} bits. The drive's undetectable error rate is 1 in 10^{27} bits read.

Error-correction Code (ECC)

The use of Cyclic Redundancy Checking (CRC), two-level orthogonal Error Correction Coding (ECC) provides a very low probability of encountering a hard error. During the read process, ECC correction is performed on the fly without affecting tape streaming.

There are two levels of Error Correction Coding (ECC). These two levels are orthogonal – that is, an ECC codeword at one level intersects ECC codewords at the other level just once, which means there will be only one common symbol between them. The two levels are called C1 and C2.

C1 ECC

As data is written to memory from the Data Processing unit, the DMA / ECC interface generates C1 ECC bytes and writes them to memory.

As data is written to tape, the C1 ECC is checked and an interrupt generated if there is an error. The C1 ECC read from memory is the ECC that is written to tape.

When data is read from tape and stored into memory, C1 ECC is checked.

- If the C1 ECC is good, that codeword pair's "Valid" bit is set.
- Otherwise, a pointer to the invalid Codeword Pair is passed to the C1 ECC correction engine.
 - If the C1 ECC correction engine can correct the error, then the corrected bytes are written to memory, and the Valid bit is set.
 - Otherwise, the Valid bit is left cleared.

As data is read from memory to the Data Processor for decompression, the C1 ECC is again checked and an interrupt generated if it is not correct.

C2 ECC

C2 ECC involves three distinct operations:

- 1 Encoding:** Generating C2 ECC bytes from data bytes (performed by ECC co-processor hardware)
- 2 Decoding:** Generating ECC syndromes from data and ECC bytes, testing for all-zeroes (performed by ECC co-processor hardware)

3 Correction: Generating corrected data from syndromes.

The correction depends on the number and types of errors involved:

- For one known C1 codeword pair in error in a sub-data set (C2 codeword), the operation is performed by the ECC co-processor hardware.
- For two or more known C1 codeword pairs in error, the matrix is computed by firmware and the correction is performed by hardware.
- For one or more unknown C1 codeword pairs, syndromes are generated by hardware, error location is computed by firmware, the matrix is computed by firmware and the correction is performed by hardware.

Servo-tracking Faults

During a write operation, if the servo system detects an error that may result in adjacent data tracks being over-written, the write operation is aborted. The write operation will not continue until the correct servo tracking is re-established.

Data Compression

Typical data streams of text, graphics, software code, or other forms of data contain repeated information of some sort, whether it is at the text level where you can readily recognize regular repetitions of a single word, or at the binary level where the repetitions are in bits or bytes. Although most data is unique and random, the binary level data exhibits patterns of various sizes that repeat with varying degrees of regularity.

Storage efficiency is increased if the redundancies or repetition in the data are removed before the data is recorded to tape. Data compression technology significantly reduces or eliminates redundancies in data before recording the information to tape. This increases the amount of data that can be stored on a finite medium and increases the overall storage efficiency of the system.

With data compression, the redundant information in a data stream is identified and represented by codewords or symbols, which allow the same data to be recorded in a fewer number of bits. These codewords or

symbols point back to the original data string, using fewer characters to represent the strings. Because these smaller symbols are substituted for the longer strings of data, more data can be stored in the same physical space.

Some important benefits result from data compression in tape drives:

- The same amount of information can be stored on a smaller length of tape.
- More data can be stored on a given length of tape.
- Performance can more closely parallel to that of high-transfer-rate computers.
- More information can be transferred in the same time interval.

Data Compression Considerations

In an effective data-compression method, several factors are important:

- The amount of compression. The amount of compression is measured by the compression ratio. This ratio compares the amount of uncompressed data to the amount of compressed data. It is obtained by dividing the size of the uncompressed data by the size of the compressed data.
- The speed with which data is compressed and decompressed relative to the host transfer rate.
- The types of data to be compressed.
- The data integrity of the compressed data.

The amount of compression possible in a data stream depends on factors such as:

- Data pattern
- Compression algorithm
- Pattern repetition length
- Pattern repetition frequency
- Object size (block of information to be compressed)
- Starting pattern chosen

The transfer rate depends on factors such as:

- Compression ratio
- Drive buffer size
- Host computer input/output (I/O) speed
- Effective disc speeds of the host computer
- Record lengths that the host computer transmits

Data compression algorithms can be tailored to provide maximum compression for specific types of data. Because varying types of data are encountered in normal day-to-day operating circumstances, however, an effective data compression method for a tape drive must serve various data types. Additionally, the data compression method must adapt to different data types, automatically providing optimum handling for all types of data.

Intelligent Data Compression

The tape's compressed capacity is maximized through the use of intelligent data compression. The intelligent data compression hardware determines the compressibility of each record. If the size of the record is larger after a compression attempt than the native (uncompressed) size, then the record is written in its native form.

The intelligent data compression utilizes two compression schemes:

- Scheme-1 is a LZ1-based compression scheme using a history buffer to achieve data compression.
- Scheme-2 is a pass-through compression scheme designed to pass uncompressible data through with minimal expansion.

There are three specific requirements for compliance with the LTO specification.

- The output data stream must be decompressible following LTO rules to create the input sequence of records and File Marks perfectly.
- An LTO compressed data stream may not contain any of the eight reserved Control Symbols.
- While control symbols allow switching to Scheme 2, this should never be used by operational software because this capability is only for diagnostic and testing purposes.

Software data compression should never be used because the LTO-3 Tape Drive's built-in intelligent data compression is much more efficient than software data compression systems.

The LTO-3 Tape Drive uses a derivative of ALDC-2 lossless data compression that includes additional control codes for intelligent data compression.

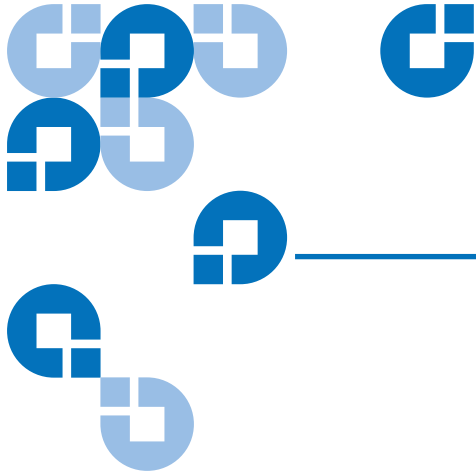

Chapter 5 Specifications

This chapter provides technical specifications for the LTO-3 Tape Drive.

The topics covered in this chapter are:

- [Physical Specifications](#)
- [Power Specifications](#)
- [Drive Performance Specifications](#)
- [Environmental Requirements](#)
- [Reliability](#)
- [Mean Time Between Failures](#)
- [LTO Cartridge Specifications](#)
- [Regulatory Compliance](#)
- [Disposal of Electrical and Electronic Equipment](#)

Physical Specifications

[Table 5](#) lists the physical specifications of the LTO-3 Tape Drive.

Table 5 Physical Specifications

Specification	Internal SCSI Drive without Bezel	Internal SCSI Drive with Bezel	Desktop SCSI Drive
Height	3.25 inches (82.6 mm) max	3.31 inches (84.3 mm)	6.8 inches ¹ (172.7 mm)
Width	5.75 inches (146.05 ± 0.25)	5.81 inches (147.8 mm)	7.61 inches (193.3 mm)
Length	8.06 inches (205 mm)	8.3 inches (212 mm) max	12.17 inches ² (309.1 mm)
Weight	6.2 lb. (2.82 kg)	6.5 lb. (2.95 kg)	14.5 lb. (6.58 kg)

¹ Includes rubber feet (case alone is 6.44 inches high).

² Includes front bezel and fan grill (case alone is 11.9 inches long).

Figure 14 shows the dimensions of the internal LTO-3 Tape Drive.

Figure 14 Internal
LTO-3 Tape Drive
Dimensions

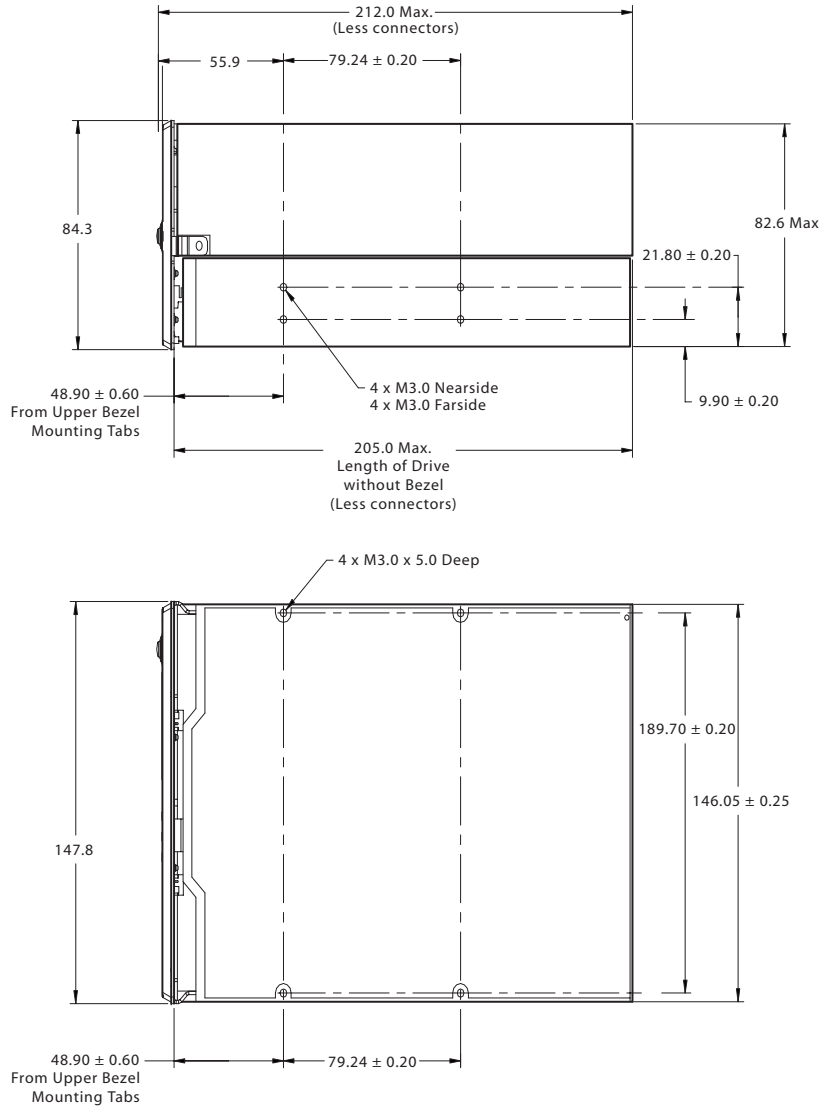

Power Specifications

The desktop LTO-3 Tape Drive comes with a built-in 90-260VAC (47-63 Hz) automatic switching power supply.

Maximum voltage and power specifications for the internal LTO-3 Tape Drive is listed in the tables below. Specifications are the same for SCSI drives unless otherwise noted.

Table 6 Voltage and Current

Specification	+12 VDC	+ 5VDC
DC Voltage Tolerance	12.00 + or - 10%	5.00 + or - 5%
Non-operating max voltage	14 Volts peak	7 Volts peak
Max operating current		
Continuous:	1.2 amps RMS	3.5 amps max RMS*
Peak:	4.0 amps (1 sec max)	N/A
Standby current (max)	1.0 amps RMS	2.0 amps RMS*
Ripple (peak-to-peak)	≤ 100 mV	≤ 100 mV

* RMS parameters measured at the power connector using a true RMS digital meter.

Table 7 Power Dissipation

Specification	LTO-3
Max Standby Power	17 watts RMS*
Max Continuous Operating Power	42 watts RMS*
Max Peak Operating Power	65 watts RMS (1 sec max)

* RMS parameters measured at the power connector using a true RMS digital meter.

Drive Performance Specifications

[Table 8](#) lists the performance specifications for the LTO-3 Tape Drive.

Table 8 Drive Performance Specifications

Specification	Value
Capacity LTO Ultrium 3 (680 m)	400 Gbytes (native)
Recording density	5,120 RLL-encoded ONEs per mm
Flux density	10249 cells per mm
Track density	70 tracks per mm
Error recovery	Read-after-write Reed Solomon ECC (2 levels)
Recording unrecoverable errors	Less than 1 in 10^{17} data bits
Recording undetectable errors	Less than 1 in 10^{27} data bits
Tape drive type	LTO (Ultrium)
Head configuration	2 bumps 16 thin-film write heads per bump 16 MR read heads per bump 2 MR servo heads per bump
Recording format	Ultrium 16-channel (U-38)
Recording method	0, 13/11 RLL
Transfer rate (sustained)	68 Mbytes/second (max, native)
Synchronous transfer rate (burst)	160 Mbytes per sec max
Cartridge unload time	30 seconds

Specification	Value
Average rewind time (609-m tape)	≥ 51 seconds
Maximum rewind time (609-m tape)	≤ 115 seconds
Average data access time (609-m tape) from BOW (beginning of wrap)	58 seconds
Maximum data access time (609-m tape) from BOW	115 seconds
Average rewind time (609-m tape)	≤ 115 seconds
Tape speed	Up to 5.9 meters per second

Environmental Requirements

[Table 9](#) lists the environmental specifications for the LTO-3 Tape Drive.

Table 9 Environmental Requirements

Specification	Operational	Non-operational
Temperature	+50° to +104°F (+10° to + 40°C)	-40° to +149°F (-40° to + 66°C)
Airflow requirements	Internal: 9 CFM (front to back)	N/A
Thermal gradient	11°C per hour (10-40°C)	11°C per hour (10-40°C)
Relative humidity	20% to 80% non-condensing	10% to 95% non-condensing

Specification	Operational	Non-operational
Humidity gradient	10% per hour	10% per hour
Altitude	max 10,000 feet MSL (at 25°C)	40,000 feet (power off)
Shock (1/2 sine wave)	10 Gs peak, 11 msec	40 Gs peak, 11 msec
Vibration (sweep test)	0.005 inches DA (5-43 Hz) 0.50 G peak (43-1000 Hz) sweep rate 5-1000Hz; 1.0 octave per minute	0.1 inches (5--15Hz) 1.0 G (15-500 Hz) 1.0 octave per minute
Acoustic level idling (A-wt sum)	52 dBA maximum 5.0 LwA Bels	–
Acoustic level operational (A-wt sum)	57 dBA maximum 5.5 LwA Bels	–

Injected Noise

The internal drive operates without degradation of error rates with 100 mV of noise injected between the chassis and 0 V at the power connector at any frequency between 45 Hz and 20 MHz.

Reliability

The LTO-3 Tape Drive is designed for maximum reliability and data integrity. [Table 10](#) summarizes the reliability specifications.

Table 10 Reliability

Specification	Description
Non-recoverable error rate	Less than 1 in 10^{17} bits
Error recovery and control	<ul style="list-style-type: none">• Error correction code techniques (C1 and C2 ECC)• Read-after-write (RAW)• Error monitoring and reporting (error log)• Retry on
Mean time between failures (MTBF)	250,000 hours MTBF at 100% duty cycle: power applied and tape moving continuously (Desktop drive; 50,000 hours at full load and 25°C)
Cartridge load/unload	300,000 cartridge load/unload cycles (no thread)
Mean time to replace (MTTR)	Less than 30 minutes

Mean Time Between Failures

The mean time between failures (MTBF) for the internal drive is specified at 250,000 hours minimum. This specification includes all power-on and operational time but excludes maintenance periods. Operational time is assumed to be 100% of the power-on time. Operational time is the time the tape is loaded.

The MTBF for the desktop drive power supply is 50,000 hours with the unit operated at full load and 25°C.

Note: The MTBF rating does not represent any particular drive, but is derived from a large database of test samples. Actual rates may vary from unit to unit.

Mean Time to Replace

The mean time to replace (MTTR) is the average time required by a qualified service technician to diagnose a defective drive and to install a replacement drive. The MTTR for LTO products is less than 0.5 hour (30 minutes).

The Quantum LTO drives are field-replaceable units. If a problem occurs with a subassembly or component in the drive, you should replace the entire unit. Return the drive to the factory in its original packaging. Contact your distributor, dealer, your computer system company or your Quantum sales representative to arrange the return.

LTO Cartridge Specifications

Environmental Considerations

[Table 11](#) lists the basic environmental tolerances for LTO Ultrium cartridges.

Table 11 Environmental Tolerances

Specification	Value
Operating temperature	10°C to 40°C
Relative humidity	10% to 80% storage, 20% to 80% operating
Wet bulb temperature	26° C max
Max localized temperature-permanent tape damage	Greater than 52°C

If during storage and/or transportation a cartridge has been exposed to conditions outside the above values, it must be conditioned before use in the operating environment. The conditioning shall be exposure to the operating environment for a time equal to, or greater than, the time away from the operating environment, up to a maximum of 24 hours. There shall be no deposit of moisture anywhere on or in the cartridge.

The stray magnetic field at any point on the tape shall not exceed 4000 A/m.

Cartridge Memory

Each Ultrium cartridge has 4 Kbytes of nonvolatile memory: 3 Kbytes are used to store tape-directory and hardware specific information. 1 Kbyte is available for application and OEM use. The cartridge memory is powered, read, and written to via a radio-frequency link.

Cartridge Reliability

Recommended cartridge use: After 5,000 load/unload cycles, replace the cartridge to insure data integrity.

Regulatory Compliance

These drives comply with the safety and EMC regulations listed in the following tables.

Safety Compliance

Country	Regulatory Organization	Compliant to:
United States	Underwriters Laboratories (UL)	UL 1950 – 3rd edition
Canada	Canadian Standards Association (CSA)	CSA 22.2 950-95
Germany	Technischer Überwachungs-Verein (TUV) Rheinland	IEC 950 / EN60950, (including amendments A1, A2, A3, A4, A11)
Mexico	Normas Oficiales Mexicanas (NOM), similar to UL	NOM standards
Singapore	Productivity and Standards Board (PSB)	PSB safety certification
South Korea	JEON	JEON safety certification
Argentina	Instituto Argentino de Racionalization de Materiales (IRAM)	IRAM safety certification China

Country	Regulatory Organization	Compliant to:
China	Chinese Commodity Import Bureau (CCIB)	CCIB safety certification
EU member nations	Comité Européen de Normalisation Electrotechnique – the European Committee for Electrotechnical Standardization (CENELEC)	IEC 950 / EN60950 (including amendments A1, A2, A3, A4, A11)
Member nations of IECEE*	IECEE* International Electrotechnical Commission on Electrical Equipment (IECEE) for Mutual Recognition of Test Certificates for Electrical Equipment “CB Scheme”	CB Scheme per IEC 950 / EN60950 with details and exceptions for each member country
Hungary	MEEI Budapest	CB Scheme
Czech Republic	EZU Praha	CB Scheme
Poland	PCBC BBJ-SEP	CB Scheme
Russia	GOSSTANDART (GOST)	CB Scheme
Bulgaria	CSM	CB Scheme
Malaysia	JBE SIRIM	CB Scheme
Thailand	TISI	CB Scheme
India	STQC BIS	
South Africa	SABS	CB Scheme
Israel	SII	

* Member nations of the IECEE include Austria, Australia, Belgium, Canada, China (PR), Czech Republic, Denmark, Finland, France, Germany, Hungary, India, Ireland, Israel, Italy, Japan, South Korea, Netherlands, Norway, Poland, Russian Federation, Singapore, Slovakia, Slovenia, South Africa, Spain, Switzerland, United Kingdom, USA, Yugoslavia.

Electromagnetic Compatibility (EMC)

Country	Regulatory Organization	Compliant to:
United States	Federal Communications Commission (FCC)	Title 47: Code of Federal Regulations, Part 15, Subpart B, Class B: Digital Device (47CFR15B)
Canada	Industry Canada Digital Apparatus - Interference-Causing Equipment Standard (ICES-003)	ICES-003 Class B: Digital Apparatus
EU member nations	CE	Emissions per CISPR 22:1997 - EN55022:1998 and Immunity per CISPR 24:1997 - EN55024:1998
Australia and New Zealand	Standards Australia Spectrum Management "C-Tick"	AS/NZS 3548-1995 (same as CISPR 22)
Japan	Voluntary Control Council for Interface (VCCI)	This is a voluntary compliance standard; the drives meet it via CE compliance
South Korea	Radio Research Lab of Korea (RRL)	RRL EMC certification
Taiwan	Bureau of Commodity Inspection and Quarantine (BSMI)	BSMI EMC certification
China	Chinese Commodity Import Bureau (CCIB)	CCIB EMC Certification
Poland	PREDOM-OBR	CISPR-22, Class B
Russia	GOSSTANDART (GOST)	CISPR-22, Class B
Bulgaria	CSM	CISPR-22, Class B
Israel	SII	CISPR-22, Class B

Note: Use these drives only in equipment where the combination has been determined to be suitable by an appropriate certification organization (for example, Underwriters Laboratories Inc. or the Canadian Standards Association in North America).

You should also consider the following safety points:

- Install the drive in an enclosure that limits the user's access to live parts, gives adequate system stability and provides the necessary grounding for the drive.
- Provide the correct voltages (+5 VDC and +12 VDC) based on the regulation applied – Extra Low Voltage (SELV) for UL and CSA, and Safety Extra Low Voltage for BSI and VDE (if applicable).

Disposal of Electrical and Electronic Equipment

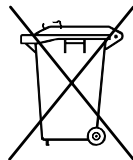

This symbol on the product or on its packaging indicates that this product should not be disposed of with your other waste. Instead, it should be handed over to a designated collection point for the recycling of electrical and electronic equipment. The separate collection and recycling of your waste equipment at the time of disposal will help to conserve natural resources and ensure that it is recycled in a manner that protects

human health and the environment. For more information about where you can drop off your waste equipment for recycling, please visit our website at qcare.quantum.com or contact your local government authority, your household waste disposal service or the business from which you purchased the product.

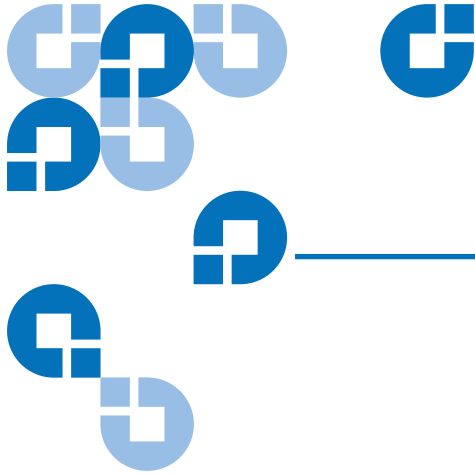

Chapter 6 UNIX Settings

This chapter describes how to configure various UNIX systems to recognize and obtain optimal performance from the LTO-3 Tape Drive.

The topics covered in this chapter are:

- [A Word About SCSI Controllers](#)
- [Configuring for the DEC/Compaq UNIX Environment](#)
- [Configuring for the Sun Environment \(Solaris 2.4, 2.5, 2.6, 7, 8, and 9\)](#)
- [Configuring for the IBM AIX Environment \(AIX Version 4.1.x and later\)](#) on page 58
- [Configuring for SCO Open Server 5.0.x](#) on page 59
- [Configuring for Linux](#) on page 61
- [Configuring for SGI Irix](#) on page 63
- [Configuring for HP-UX 11.0](#) on page 64

A Word About SCSI Controllers

The LTO-3 Tape Drive transfers data natively at 68 Mbytes per second. It supports the SCSI Ultra 160 specification and can transfer data at burst rates of up to 320 Mbytes per second. To achieve maximum drive performance, it is important to choose high-performance disk drives for your system, as well as high-performance SCSI controllers.

Configuring for the DEC/Compaq UNIX Environment

Finding Existing SCSI Controllers and Devices

SCSI ID #7 is almost always dedicated to the SCSI controller. Never configure your target device for ID 7 unless you are absolutely sure that the controller is not addressed for ID 7.

Configuring Digital UNIX Version 4.0 and later/Compaq Tru64 Unix 5.x

Use File Manager to open the file **/etc/ddr.dbase** and create an entry as follows:

```
SCSIDEVICE
#
Type=tape
Name="CERTANCE""ULTRIUM 3"
#
PARAMETERS:
  TypeSubClass=tk
  TagQueueDepth=0
  MaxTransferSize=0x0ffffff#(16MB-1)
  ReadyTimeSeconds=180#seconds
  CMD_PreventAllow=supported
  CMD_ExtReserveRelease=supported
  BlockSize=0
  PwrMgmt_capable=0
DENSITY:
#
DensityNumber=0,2,3,4,5,6,7
DensityCode=default
CompressionCode=0x0
Buffered=0x1
```

```
DENSITY:  
#  
DensityNumber=1  
DensityCode=default  
CompressionCode=0x1  
Buffered=0x1
```

Save the file. Then run the following command:

ddr_config-c

ddr_config takes the default input file, **ddr.dbase**, and builds a new device database. This command takes effect immediately without having to rebuild the kernel.

Note: **ddr.dbase** is a Unix shell script and is not written in C. This means # is used to signify a comment, not /* and */ or //, as used in C. Make sure any comments included in this file are preceded with the # character.

To enable the tape driver to turn on data compression when writing data to tape use the **.c.** option.

For commands that use density and tape size settings, the tape density is 124,000 bpi and the tape length is 1800 feet. For commands that use a blocking factor, we recommend a blocking factor of 64 as a minimum (128 is recommended).

Configuring for the Sun Environment (Solaris 2.4, 2.5, 2.6, 7, 8, and 9)

Use the following for attaching the LTO-3 Tape Drive to Sun Sparc and Intel systems.

Finding Current SCSI Controllers and Targets

To properly attach SCSI devices to hosts it is necessary to ensure that each target device has a unique SCSI address. The commands **.modinfo.** and **.dmesg.** can be used to find the SCSI controllers in use and the SCSI target devices installed.

For example, the command `.dmesg | egrep .target. | sort | uniq.` can find all SCSI controllers and SCSI targets. The output may look similar to:

```
sd32 at ithps0: target2 lun0
sd34 at ithps0: target4 lun0
st21 at ithps1: target0 lun0
st22 at ithps1: target1 lun0
```

In this case, the LTO-3 Tape Drive can be set for SCSI ID address 2 through 6 and attached to controller `ithps1` (this particular controller also supports SCSI addresses 8 through 15).

Types of Controllers

You may be able to view the main pages of three types of SCSI controllers for Sun Sparc systems:

- `esp`
- `glm`
- `isp`

We recommend that the LTO-3 Tape Drive not be attached to `esp` controllers. This controller is not fast enough to work with the LTO-3 Tape Drive. The minimum recommended controller would be a `glm` controller, which is an Ultra Wide controller.

We recommend Ultra 160 SCSI-capable controllers capable of 80MB/s data transfer as a minimum. Slow backups will result if using slower SCSI controllers.

Configuring the Device File `st.conf`

To configure Solaris 2.4 and above to use the LTO-3 Tape Drive correctly, add the following lines to the file `st.conf` in the directory `/kernel/drv.`

```
tape-config-list=
"SEAGATE ULTRIUM06242-XXX", "Seagate LTO 1", "SEAGATE_LTO1",
"CERTANCEULTRIUM 2", "Seagate LTO 2", "Certance_LTO2",
"CERTANCEULTRIUM 3", "Seagate LTO 3", "ULTRIUM",
```

THE LAST ENTRY IN THIS SECTION MUST END WITH A SEMICOLON

```
SEAGATE_LTO1 = 1,0x3b,0,0x1d639,4,0x00,0x00,0x00,0x00,1;
Certance_LTO2 = 1,0x3b,0,0x1d639,4,0x00,0x00,0x00,0x00,1;
Certance_LTO3 = 1,0x3b,0,0x1d639,4,0x00,0x00,0x00,0x00,1;
```

The value 0x1d639 equates to the way that the LTO-3 Tape Drive is configured to operate in the Solaris environment. This value enables the LTO-3 Tape Drive to:

Support variable length records (variable length block size)

- Backspace over files (same as **.mt bsf.** command to backspace over filemarks)
- Backspace over records (same as **.mt bsr.**, backspace over individual tape blocks)
- Long time-out for long erase function (it is not recommended to try and erase the entire tape)
- The LTO-3 Tape Drive knows when end of data has been encountered
- Device driver is unloadable
- Long timeouts (5 times longer than normal)
- Buffered writes supported
- Variable record size not limited to 64k
- Uses Mode Select Page 10h to enable/disable compression

Once **st.conf** has been modified, the kernel must be reconfigured by booting the system using the **boot-r** command. If you are replacing a tape device with the same SCSI ID you may want to delete the st devices from the **/dev/rmt** directory (recommended).

When using commands that require a blocking factor such as tar or ufsdump, we suggest a minimum factor of 64. The preferred factor is 128.

For commands that use density and tape size settings the tape density is 124,000 bpi and the tape length is 1800 feet. We suggest using the **ufsdump/ufsrestore** commands. These commands automatically detect end of tape without the need of the density and tape length settings.

To enable the st driver to turn on data compression when writing data to tape use the **.c.** option. For example, **tar cf /dev/rmt/0c** causes the tape drive to compress the data before writing the data to tape.

Configuring for the IBM AIX Environment (AIX Version 4.1.x and later)

Finding Existing SCSI Controllers and Devices

Enter the following command: **lsdev-Cs scsi**. This shows all the SCSI target IDs known to the system. Note the SCSI target IDs and choose a SCSI ID for the LTO-3 Tape Drive that will not conflict with the IDs shown from the `lsdev` command.

SCSI ID #7 is almost always dedicated to the SCSI controller. Never configure your target device for ID 7 unless you are absolutely sure that the controller is not addressed for ID 7.

Configuring the LTO-3 Tape Drives using SMIT

The LTO-3 Tape Drive can be configured to work with AIX Versions 4.1.x and later by using the **SMIT .Other SCSI Tape Drive**. option.

Note: Record the SCSI ID of the tape drive before installing it.

To configure AIX using the **SMIT** utility, use the following procedure:

- 1 Enter **SMIT** at the Tape Drive menu by typing **smit tape**
- 2 Select **Add a Tape Drive**.
- 3 Select the type of tape drive you will be adding. Use the **Other SCSI Tape Drive** option.
- 4 Select the Parent SCSI Adapter from the available list. The **Add a tape Drive "Entry Fields"** appears.
- 5 Some of the standard options can be changed to maximize drive performance and functionality:

Set the **Connection Address with the Drives Target and Lun** (always use Lun 0). In the list, the Target is the first number and the Lun is the second. For example, if the drive is ID 5, choose 5,0.

Set the **BLOCK** size to **0**.

Set **Use DEVICE BUFFERS during writes** to **yes**.

Set **RETURN error on tape change or reset** to **no**.

Set **Use EXTENDED file marks** to **yes**.

Set **RESERVE/RELEASE support** to **yes**.

Set **BLOCK SIZE for variable length support (Num.)** to **0**.

Set **Density 1** to **0**.

- 6 Leave the **Set delay. . .** and **Set timeout. . .** lines at the default value.
- 7 Click **OK** and the drive will be installed in the system database, and devices created. There is no need to reboot the system.
- 8 Exit **SMIT**.

Note: We suggest using the AIX commands **.backup** and **restore** when transferring data to and from the LTO-3 Tape Drive. These commands transfer data more quickly than other commands such as **tar** and **cpio**. For **cpio**, we suggest a blocking factor of 128. For **tar**, we suggest using the **.N** option and a factor of 128. Some older systems with poor video controllers may experience a reduction in performance when using the **.v** option, which prints the path names on the standard console during the backup. Unless there is a real need to see the filenames as they are backed up we suggest not using the **.v** option. For commands that use density and tape size settings the tape density is 124,000 bpi and the tape length is 1800 feet.

Configuring for SCO Open Server 5.0.x

Finding Existing SCSI Controllers and Devices

The files **/usr/adm/hwconfig** and **/var/adm/messages** list the devices found during boot up of Open Server. The current SCSI controllers can be found using the command:

```
grep adapter /usr/adm/hwconfig
```

This command produces output similar to:

```
%adapter 0x6400-0x64FF 11 type=alad ha=0  
bus=0 id=7 fts=st0.
```

The current tape drives can be found using the command:

```
grep tape /usr/adm/hwconfig
```

This command produces output similar to:

```
%tape type=S ha=0 id=6 lun=0 bus=0 ht=alad
```

The information above shows that an Adaptec SCSI controller is installed (alad) and a SCSI tape drive (type=s) is installed as target id 6. SCSI ID #7 is almost always dedicated to the SCSI controller. Never configure your target device for ID 7 unless you are absolutely sure the controller is not addressed for ID 7.

Configuring the LTO-3 Tape Drive with mkdev

Once connected to the system, installation of the drive is performed using the following command:

mkdevtape

A numeric-based menu appears. If you are replacing an existing SCSI tape drive, use option 3 to remove the existing tape drive from the configuration files. Then follow the instructions below to add an LTO-3 Tape Drive.

- 1 From the menu, choose **Configure a SCSI or Enhanced IDE tape drive**.
- 2 From the next menu, choose **Install a SCSI tape drive**.
- 3 When prompted, enter the SCSI adapter string. To view the list of supported SCSI adapters, use the h option.
- 4 Enter the number of the SCSI host adapter attached to the drive. If one SCSI adapter exists, enter the number zero (0).
- 5 Enter the number of the SCSI bus attached to the drive. Refer to the SCSI adapter documentation. For many adapters this will be zero (0).
- 6 Enter the SCSI ID of the tape drive.
- 7 Enter the number zero (0) for the LUN of the device.
- 8 When prompted to **Update the SCSI configuration? (y/n)**, enter **y**.
- 9 When prompted for Vendor Identification string, enter **CERTANCE**.
- 10 When prompted to enter the SCSI version to which the tape drive conforms, enter the number three (3).
- 11 When prompted to enter the **Response Data Format** the tape drive uses, enter the number two (2).
- 12 When prompted, choose the **Generic SCSI-1/SCSI-2** tape drive option.

- 13 When the process takes you back to the two Main Menu screens, press **q**.
- 14 When asked to create a new kernel, enter **yes**.
- 15 When asked if you want the new kernel to boot by default press **y**.
- 16 When asked if you want the kernel environment to be rebuilt press **y**.
- 17 Reboot the system.

Note: Not all of the SCO “tape” commands will operate or be applicable to the LTO-3 Tape Drive (execute the command `.man tape` for the specifics on how the tape command works). The following tape commands are not available for use with the LTO-3 Tape Drive: **getcomp**, **setcomp** (the LTO-3 Tape Drive will always compress the data before writing the data to tape under SCO Open Server 5.0.x), **partition**, **setpart**, **getpart**, **getspeed**, **setspeed**, **rsm**, **wsm**. The following tape commands are available for use with the LTO-3 Tape Drive: **status**, **load**, **reset**, **rewind**, **retention**, **getblk**, **setblk**, **unload**, **eod**.

When using the GUI Backup Manager utility set the block size to 32768 minimum, 65536 preferred. When using commands such as **tar** we suggest using the tape command to set the block size to 512 and then using a blocking factor of 80 for the tar command. For commands that use density and tape size settings the tape density is 124,000 bpi and the tape length is 1800 feet.

Configuring for Linux

Finding Existing SCSI Controllers and Devices

Before installing the LTO-3 Tape Drive, ensure that the requisite SCSI controllers and device drivers are installed on your system.

To find existing SCSI controllers execute the command:

```
dmesg | grep SCSI
```

You may see output similar to:

```
(scsi0)<Adaptec AHA-294XX Ultra160 SCSI host  
adapter> found at PCI 0/16/0
```

To find existing SCSI devices execute the command:

cat /proc/scsi/scsi

You may see output similar to:

```
Host: scsi0 Channel: 0 Id:6 Lun:00  
Vendor: CERTANCE Model: ULTRIUM 3  
Type: SequentialAccess ANSI SCSI Revision 04
```

Use the output of these two commands to see which SCSI target ID numbers are free. In the above example a tape drive is attached at target ID 6. SCSI ID #7 is almost always dedicated to the SCSI controller. Never configure your target device for ID 7 unless you are absolutely sure that the controller is not addressed for ID 7.

The widely available distributions of Linux automatically install the proper SCSI and tape device drivers. If you executed the `cat` command above, you have ensured that the SCSI driver for your controller is installed. To view currently loaded modules, execute the `lsmod` command. Ensure that one of the entries is `st`.

To view the `st` device number for your attached tape drive, execute the command:

dmesg | grep tape

You should see output similar to:

```
Detected SCSI tape st0 and scsi0 . . .
```

Using the LTO-3 Tape Drive

The LTO-3 Tape Drive can be configured via the `mt` command options and a default configuration can be setup using the `stsetoptions` command from within the `mt` command. Refer to the man page for `mt` for details. We suggest not using the `erase` command nor commands which attempt to partition the tape. Partitioning is not supported in the LTO format.

For commands that use density and tape size settings, the tape density is 124,000 bpi and the tape length is 1800 feet. For commands that use a blocking factor, we suggest a factor of 128.

Configuring for SGI Irix

Finding Current SCSI Controllers and Targets

To properly attach SCSI devices to hosts it is necessary to ensure that each target device has a unique SCSI address. The command `hinvt` can be used to find all attached SCSI controllers and target devices. To search for all SCSI controllers and devices use the command:

hinvt -v | grep SCSI

The output of the command will be similar to the following:

```
Integral SCSI controller 0: Version ADAPTEC 7880
Disk drive unit 1 on SCSI controller 0
CD ROM unit 4 on SCSI controller 0
Integral SCSI controller 1: Version ADAPTEC 7880
Tape drive: unit 6 on SCSI controller 1: DAT
```

This output shows that a tape drive is present on SCSI controller 1 at SCSI ID address #6. Available SCSI IDs are

- 0,2,3,5 6, 8 - 15 on controller 0
- 1 - 5 and 8 - 15 on controller 1 (this controller supports Wide/Ultra SCSI)

Note: SCSI ID #7 is almost always dedicated to the SCSI controller. Never configure your target device for ID 7 unless you are absolutely sure that the controller is not addressed for ID 7. See [table 2](#) on page 16 to view how to set the SCSI ID address jumpers for the LTO-3 Tape Drives.

Modifying the IRIX Configuration File

To attach the LTO-3 Tape Drive to IRIX the file `.scsi` needs to be modified by a text editor. The file can be found in `/var/sysgen/master.d`. Open the file and use the text editor to add the following at the end of the tape device entries:

For IRIX 6.4/6.5

```
{DATTAPE, TPDAT, 8, 7, "CERTANCE", "ULTRIUM 3", 0, 0, {0},
MTCAN_BSF | MTCAN_BSR | MTCAN_APPEND | MTCAN_SETMK |
MTCAN_PREV | MTCAN_SYNC | MTCAN_SPEOD | MTCAN_CHKRDY |
MTCAN_VAR | MTCAN_SETSZ | MTCAN_SILI | MTCAN_SEEK |
```

```
M TCAN_COMPRESS,  
40, 5*60, 10*60, 10*60, 3*3600, 512, 256*512,  
tpsc_default_dens_count, tpsc_defalt_hwg_dens_names,  
tpsc_default_alias_dens_names, {0}, 0, 0, 0, 0, (u_char*) 0},
```

After modifying the configuration file, recompile the kernel with the `autoconfig` command and reboot the system. If you are replacing an existing storage device with the same SCSI ID remove the device files prior to using the **autoconfig** command and rebooting the system.

Configuring for HP-UX 11.0

Finding Current Hardware/Driver Configuration

To find currently installed SCSI controllers and devices, use the command `ioscan-f`. This command lists all the system devices and their device names.

Attaching the LTO-3 Tape Drive

Choose a SCSI address that does not conflict with any already attached SCSI devices on your SCSI controller. See [figure 2](#) for jumper installation for the LTO-3 internal drive. Attach the LTO-3 Tape Drive and apply power to the drive(s) and the host system. After the boot process completes and you log in as superuser, issue the command:

```
ioscan -C tape -f.
```

You should see output similar to:

```
Class I H/WPath Driver S/WState H/Wtype Description  
Tape 7 8/12.6.0 stape Claimed Device CERTANCE ULTRIUM
```

From the root directory and as superuser, issue the command:

```
/sbin/insf -C tape.
```

Then issue the command:

```
/sbin/mksf -d stape -H X/X.X.X -l y -c 1  
-n -u /dev/rmt/zcnb
```

Where:

- **x** is the data under **H/WPath** from the **ioscan**.
- **y** is the data under **I** from the **ioscan**.
- **z** is the tape device identifier number.

You can execute an **ls** command for the **/dev/rmt** directory to choose an identifier number that has not already been used. You can also choose a unique device name such as **cnb** to more easily remember which device name will enable data compression during write. Refer to the man pages for **mksf** to review settings for **rewind/no rewind**, **Berkeley mode**, and **AT&T mode**.

After performing the **insf** and **mksf** commands, use the command **ioscan -fn | grep -C tape** to check the installation. You should see output showing the hardware and device addressing and also the device name attached to the LTO-3 Tape Drive.

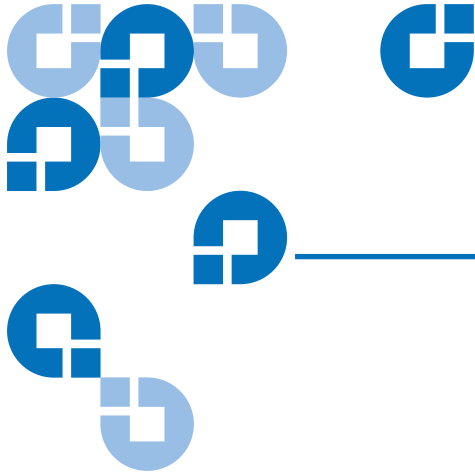

Chapter 7

Troubleshooting Guide

This chapter contains best practices for getting the most out of your LTO-3 tape drive. This chapter also contains troubleshooting information you can use to identify and resolve tape drive problems in the unlikely event you encounter a problem with your tape drive.

Topics covered in this chapter are:

- [Installation Best Practices](#)
- [Troubleshooting Suggestions](#)

Installation Best Practices

Follow SCSI Best Practices

When installing an LTO-3 Tape Drive, follow SCSI best practices to ensure trouble-free installation and operation.

SCSI Host Bus Adapters (HBA)

We strongly recommend that you attach the LTO-3 Tape Drive to SCSI controllers that support the SCSI Ultra 160 LVD interface and 160 MBytes SCSI transfer rate only.

Do Not:

- Attach the tape drives to a non-LVD SCSI controller, as this will degrade the performance of the tape drive and the performance of your backups.
- Attach non-LVD SCSI devices on the same bus cable, as this will degrade the performance of the tape drive and your backups.
- Connect the tape drive to a disk RAID controller, as this is not supported.

If you are installing an adapter, we recommend you use a SCSI LVD controller kit that includes the SCSI cable and terminator.

If installing a SCSI HBA, be sure it is supported by your operating system and your backup software application. In addition, ensure that you have the proper drivers for the HBA, if any are necessary.

Before you install the HBA, check and record your current system configuration. For example, in Windows 2000, you may find information on any currently installed SCSI HBA by:

- Double-clicking on **Administrative Tools** in the Control Panel.
- Clicking on **Computer Management > Device Manager**.
- Clicking on the SCSI host adapters listed.
- Clicking on **Properties** to view the Resources tab.

In UNIX/Linux systems, you may find information on any currently installed SCSI HBA by viewing the boot log text file. Refer to your operating system documentation for specific information on reviewing your system configuration.

After installing the SCSI HBA, reboot the system. Then ensure that the operating system recognizes the HBA and that there are no conflicts with other adapters.

Adding the Tape Drive

We recommend that the LTO-3 Tape Drive be attached to a dedicated SCSI HBA. In addition to enabling the best performance for your tape drive, a dedicated SCSI HBA reduces the chances of installation difficulties arising from duplicate SCSI IDs on the same bus channel.

Ensure that the SCSI cable is of high quality and conforms to Ultra 160 SCSI specifications. A lesser quality cable or a cable that does not conform to the Ultra 160 SCSI specification may cause intermittent write/read errors, SCSI timeouts, and corrupted data.

Troubleshooting Suggestions

Computer will not Boot

If the computer has booted up and operated properly prior to adding a SCSI HBA and tape drive, but does not boot now:

- 1 Remove the SCSI HBA controller if it is installed.
- 2 Reboot the system.
 - If the system boots normally, the problem is resolved.
 - Otherwise, ensure that SCSI HBA is compatible with system, does not have burnt components. Reseat the SCSI HBA in a different PCI slot and reboot the computer. If the system still does not boot, contact Customer Support.

Computer Boots but Does Not Recognize the Tape Drive

If the computer boots but does not recognize the tape drive:

- 1 Reboot the system and check whether the SCSI controller is seen at boot up. You should see messages similar to:

```
SCSI Adapter Manufacturer SCSI BOIS xxxxxx  
CHA: SCSI ID #, SCSI Device Name  
SCSI ID #, SCSI Device Name"
```

- If the SCSI Controller is not recognized during system boot, contact Customer Support.
- If the SCSI controller is recognized during system boot, determine whether the tape drive is recognized when the SCSI controller scans for devices. You should see messages similar to:
"SCSI ID 6 CERTANCE ULTRIUM 3 160

- If the tape drive is not recognized during the SCSI controller scan, check the **Power** LED to make sure the tape drive is receiving power.

If the Power LED is not illuminated, check the power connections to the tape drive.

Internal tape drive:

- 1** Power down the system and reseal the power connector on tape drive.
- 2** Power on the system and check the **Power LED**.
- 3** If the **Power LED** is not illuminated, replace the power connector attached to the tape drive with one from a known working device such as a CD-ROM. If the **Power LED** is illuminated, the problem was with the power connector. Otherwise, the tape drive may be bad and Customer Support should be contacted.

Desktop tape drive:

- 1** Turn power off to the tape drive and reseal the AC power cord.
- 2** Power on the tape drive and check the **Power LED**.
- 3** If the **Power LED** is not illuminated, use an AC power cord from a known working device. If the **Power LED** is illuminated, the problem was with the cable. Otherwise, the tape drive may be bad and Customer Support should be contacted.
 - If the **Power LED** is illuminated, but the tape drive is not recognized during the SCSI controller scan, use the LEDs to verify that the drive has passed its Power-On-Self-Test (POST). See [table 4](#) on page 25. If the tape drive LEDs indicate a POST failure, the tape drive may be bad. Contact Customer Support.
 - If the tape drive LEDs indicate that the drive has passed the POST, check the following connections:

Internal tape drive:

- 1 Power down the system.
- 2 Be sure there are no SCSI ID conflicts between the tape drive and other SCSI devices.
- 3 Be sure you are using a proper SCSI cable and proper termination.
- 4 Check the SCSI cable for bent pins.
- 5 Try to use SCSI cable from other SCSI controller bus chain if possible.
- 6 If these suggestions do not help, the tape drive may be bad and Customer Support should be contacted.

Desktop tape drive:

- 1 Power down system.
- 2 Power cycle desktop tape drive.
- 3 Be sure there are no SCSI ID conflict between the tape drive and other SCSI devices.
- 4 Be sure you are using a proper SCSI cable and proper termination.
- 5 Check the SCSI cable for bent pins.
- 6 Try to use SCSI cable from other SCSI controller bus chain if possible.
- 7 If these suggestions do not help, the tape drive may be bad and Customer Support should be contacted.

Tape Drive Recognized During System Boot But Not by Operating System or Application

Windows Operating System

When the tape drive is installed in a Windows operating system, Windows displays a message on the screen if it does not have a driver in place for the tape drive.

If the tape drive will be used by an ISV application, you can click on the Cancel button to remove the message. When the ISV backup software application is running, the application invokes its drivers to run the tape drive. However, if you use a native Windows operating system backup utility, you must install the proper tape driver for the tape drive.

Red Hat Linux

The tape driver for Red Hat Linux is called “**st**”. This driver is automatically installed when Red Hat Linux is installed on your system. When Red Hat Linux boots, the operating system recognizes the tape drive and installs the tape drive as a device in the **/dev** directory. If this is the first tape device in the **/dev** directory, the tape drive is known as **/dev/st0** or **/dev/nst0**.

There are various ways to view the log files to see whether Linux recognizes the tape drive. One method is to open a terminal window and issue the following command from the root directory: **dmesg | grep SCSI**

You may see output similar to:

```
(scsi0)<Adaptec AHA-294XX Ultra160 SCSI host adapter> found at PCI 0/16/0
```

You may also be able to use the command:

```
cat /proc/scsi/scsi
```

You may see output similar to:

```
Host: scsi0 Channel: 0 Id:6 Lun:00  
Vendor: CERTANCE Model: ULTRIUM 3  
Type: SequentialAccess ANSI SCSI Revision 04
```

You can also use a text editor to view the messages in the file **/var/log/** and look for tape drive entries.

Sometimes a system may have multiple tape device names in the **/dev** directory and will not know which **st** number to use. To view the **st** device number for your attached tape drive, use the command:

```
dmesg | grep tape
```

You should see output similar to:

```
Detected SCSI tape st0 and scsi0 . . .
```

Problems with Tape Drive and Cartridge

Tape will not Load into Tape Drive

- 1 Verify that the tape drive’s **Power** LED is illuminated and that all other LEDs are off. If the **Power** LED is not illuminated, refer to the procedures for troubleshooting LEDs under [Computer Boots but Does Not Recognize the Tape Drive](#) to determine why it is not illuminated.

- 2 If the **Power** LED is illuminated but other LEDs are on or flashing, check to see if other LED activity is normal or abnormal (see [table 4](#) on page 25).
- 3 If the **Power-On-Self-Test Failure** LEDs are on, contact Customer Support.
- 4 If other LEDs are on, reboot the drive by holding the front panel button for more than 5 seconds and releasing it or by power cycling the drive.
- 5 Verify that the tape drive passed the **Power-On-Self-Test** by viewing LED activity. All LEDs should be off approximately 20 to 30 seconds after the tape drive reboots.
- 6 If the **Power-On-Self-Test Failure** LEDs are on, contact Customer Support.
- 7 If all the LEDs are off, except **Power**, and a tape cannot be inserted into the tape drive, examine the tape and the inside of the tape drive.
 - Be sure there are no tape labels interfering with tape insertion.
 - Be sure tape labels are only on proper tape surfaces, and that labels are flat and not curled.
 - Be sure the tape drive opening is free of debris and tape labels.
 - Be sure the tape pin and tape are fully within the cartridge.
 - Attempt to insert a second tape if available.
- 8 If a tape still cannot be inserted into the tape drive:
 - If you are inserting a cleaning cartridge:
 - Be sure the cleaning tape is valid. The tape drive ejects unsupported cleaning tapes.
 - Be sure that the cleaning tape has not expired, see [table 4](#) on page 25 for “Cleaning Cartridge at EOT.”
 - If these suggestions do not resolve the problem, contact Customer Support.
 - If you are inserting a data tape, the tape drive may be bad. Contact Customer Support.

Tape will not Eject from the Drive

- 1 Be sure the tape drive is powered on. If the **Power** LED is not illuminated, check whether power is being applied to the system and/or the desktop tape drive if the tape drive is a desktop unit. Follow troubleshooting steps under [Computer Boots but Does Not Recognize the Tape Drive](#) on page 69 to determine why the Power LED is not illuminated.
- 2 If the **Power** LED is illuminated, determine whether the tape drive LEDs show other tape drive activity. Under normal conditions, it may take 2 to 3 minutes for the tape to eject. If only the **Drive** LED is blinking, wait for this LED to turn off before trying to eject the tape.
- 3 If the **Drive** LED alone is blinking, wait for it to turn off. Verify that no other LEDs are on or flashing. Push the eject button on tape drive.
- 4 If the **Drive** LED flashes, wait for the tape to eject (this may take up to 3 minutes). If the tape ejects, the problem has been resolved.
- 5 If a message similar to the following appears when the eject button is pushed, use the `mt offline` command to eject the tape:

You cannot eject the cartridge because the tape drive is in use. Wait until the operation is complete before ejecting the cartridge. The backup software may still have the tape drive in prevent mode so that the cartridge cannot be ejected. Use the backup software commands to eject the tape.

Note: In Unix/Linux the above message may not appear, but the operating system may still prevent the tape drive from ejecting the tape.

- 1 If the **Drive** LED is not blinking alone, see [table 4](#) on page 25 to determine whether a hardware or firmware error has occurred, or whether the **Manual Intervention** LED is flashing.
 - If there is a hardware or firmware error or the **Manual Intervention** LED is flashing — and the **Drive** LED is blinking — contact Customer Support.
 - If there is a hardware or firmware error or the **Manual Intervention** LED is flashing — and the **Drive** LED is *not* blinking — reboot the drive by holding the front panel button for more than 5 seconds and releasing it or power cycling the drive. It may take up to 5 minutes for the tape to eject.

- 2 If the **Hardware or Firmware Error** or **Manual Intervention** LED is flashing after the tape drive is rebooted, the tape may be stuck. Contact Customer Support.

Emergency Reset and Emergency Cartridge Eject

In the unlikely event the LTO-3 Tape Drive stops communicating with the host computer, use the following procedure to reset the drive and eject a cartridge (if necessary).

Caution: When you perform an emergency cartridge eject, any data currently in the drive or host's buffers will not be written to the tape and the tape record may not be correctly terminated with an End-of-Data mark. If the End-of-Data mark is not written to the tape, you will not be able to append any data to that tape unless you overwrite the existing data on the tape.

To perform an emergency reset, hold down the load/unload button between 5 to 15 seconds, and then release it.

- If there is no tape in the drive, the drive firmware reboots the drive and begins the power-on self-test sequence.
- If there is a tape in the drive, the drive ignores all outstanding SCSI commands, ejects the tape, reboots, and begins the Power-On-Self-Test sequence.

If the procedures above do not eject the cartridge from the drive, you may need to remove the cartridge manually, as described under **Manually Removing a Cartridge** on www.quantum.com/support.

Problems During Backup/Restore Operations

Backup Failures

A backup failure can be caused by various reasons. The LTO-3 Tape Drive support the **TapeAlert** standard. The following troubleshooting steps start when software logs a **TapeAlert** message. You can view the **TapeAlert** message either on the main console screen or in the backup software's log file. There may be more than one **TapeAlert** message per backup failure event.

- 1 The **TapeAlert** message or backup log shows, "The operation has stopped because an error has occurred while reading or writing data which the drive cannot correct."

A media error occurred during write or read operation on the tape drive. Review the troubleshooting procedures to ensure that the proper SCSI cabling and termination practices are being followed. Restart the backup if any changes are made to the SCSI cabling or termination or if any cables or terminator are unplugged then re-plugged.

This message may also be seen with, "The tape is from a faulty batch or the tape drive is faulty." or "The tape is damaged or the drive is faulty. Call the tape drive supplier helpline." If either of these messages also appears, use a good tape to test the drive. If the problem persists, call the tape drive supplier helpline.

- 2 Remove the data tape and insert a cleaning cartridge. After the cleaning cartridge ejects reinsert the data tape and restart the backup. If the backup succeeds, the problem is resolved.
- 3 If the backup fails, try to isolate the tape media vs. tape drive. Use diagnostic software to perform a write/read test of 4 Gbytes of data. The current data on the tape **WILL BE OVERWRITTEN AND ALL PREVIOUSLY WRITTEN DATA ON THE TAPE WILL BE DESTROYED.** Use a second tape for the diagnostic test. If the diagnostic test passes on the second tape, use the tape for the backup process and remove the first tape from the backup process.
- 4 If the diagnostic test fails on the second tape, insert a cleaning tape into the drive and repeat the diagnostic write/read test. If the diagnostic test passes on the second tape, the problem is resolved.
- 5 If the diagnostic test fails on the second tape, the tape drive may be bad. Use the diagnostic software to perform a write/read test on the first data tape. The current data on the tape **WILL BE OVERWRITTEN. ALL PREVIOUSLY WRITTEN DATA ON THE TAPE WILL BE DESTROYED.** If the diagnostic test passes on the first tape, the problem is resolved. If the diagnostic fails on the first tape, the tape is bad and should not be used any longer.
- 6 If a second data tape is not available to test with the diagnostic software, but a cleaning tape is available, insert the cleaning tape. Remove the cleaning tape after the cleaning tape ejects and restart the backup. If backup is successful, the tape drive and tape are satisfactory.
- 7 If the backup fails, use the diagnostic software to perform a write/read test of 4 Gbytes of data. The current data on the tape **WILL BE OVERWRITTEN. ALL PREVIOUSLY WRITTEN DATA ON THE TAPE WILL**

BE DESTROYED. If the tape drive passes the diagnostic write/read test, perform backup again. If the tape drive fails the diagnostic, the drive may be bad. Contact Customer Support.

Tape is Write Protected

The following troubleshooting steps start when software logged a TapeAlert message. The **TapeAlert** message can be viewed either on the main console screen or in the backup software's log file. There may be more than one **TapeAlert** message per backup failure event.

- 1** The **TapeAlert** message or backup log shows, "You are trying to write to a write-protected cartridge. Remove the write-protection or use another tape." Eject the tape from the drive and move the write protect tab to the enable position. Reinsert the tape and restart the backup.
- 2** If the **TapeAlert** message or backup log shows, "The memory in the tape cartridge has failed, which reduces performance. Do not use the cartridge for further backup operations." a Cartridge Memory chip failure may have occurred in the tape cartridge or a tape drive failure may have occurred. Use another tape to perform a backup. (This message may be seen with, "You have loaded a cartridge of a type that is read-only in this drive. The cartridge will appear as write-protected.")
- 3** Insert a second tape and restart the backup. The backup should be successful. The first tape cannot be used for further backups. If you insert a second tape for a backup and other tape alert messages appear in the backup software again, the tape drive may be bad.
- 4** If you start a backup and the software displays a message on the console a message similar to "Overwrite protection is set to _____. Click OK to overwrite the media or insert new media that can be overwritten." it indicates a software-related problem. Refer to the backup software instructions on overwrite and append settings.

Miscellaneous TapeAlert Messages

- 1** If either of the following messages appears:
The tape drive has a hardware fault:
 - 1** Eject the tape or magazine.
 - 2** Reset the drive.
 - 3** Restart the operation.

Or

The tape drive has a hardware fault:

1. Turn the tape drive off and then on again.
2. Restart the operation.
3. If the problem persists, call the tape drive supplier helpline.

Check the tape drive users manual for device specific instructions on turning the device power on and off.

To determine whether the LED activity indicates a **Hardware or Firmware Error** or **Manual Intervention Required** see [table 4](#) on page 25. If it does, power cycle the tape drive. The tape should eject. This may take several minutes.

If the tape drive ejects the tape and all LEDs are off (with the possible exception of **Cleaning Request** LED), the problem is resolved.

If the tape did not eject and the LEDs show **POST Failure, Hardware, or Firmware Error, or Manual Intervention Required**, the drive may be bad. Contact Customer Support.

- 1 If you have a problem with inserting a cleaning cassette and receive the message:

The last cleaning cartridge used in the tape drive has worn out:

- 1 Discard the worn out cleaning cartridge.
- 2 Wait for the current operation to finish.
- 3 Then use a new cleaning cartridge.

It means the cleaning cartridge is used up. Purchase a new cartridge to perform any more cleaning cycles. Normal operation of the drive is not affected. The drive will continue to automatically eject the expired cleaning cartridge.

- 2 If you insert a cleaning tape that is not expired but the tape is being ejected by the tape drive without performing the cleaning, you may see the message:

The last cleaning cartridge used in the tape drive was an invalid type:

- 1 Do not use this cleaning cartridge in this drive.
- 2 Wait for the current operation to finish.
- 3 Then use a valid cleaning cartridge.

This message means the tape drive does not recognize the cleaning tape as being of a valid type. You may have purchased a cleaning tape that is not supported by the tape drive. Purchase a supported cleaning tape.

- 3 If the tape drive issues a message to backup software to instruct you to clean the tape drive, you may see the message:

The tape drive needs cleaning:

- 1 If the operation has stopped, eject the tape and clean the drive.
- 2 If the operation has not stopped, wait for it to finish and then clean the drive.
- 3 Check the tape drive users manual for device specific cleaning instructions.

This message means you should use a supported cleaning tape.

Slow Backups

There are many factors that can make backups appear to be “slow.” To achieve the highest possible transfer rate, the LTO-3 tape drive **MUST** be attached to a Low Voltage Differential (LVD) SCSI controller capable of a minimum of 80 Mbytes/s and **MUST** not share the same SCSI bus as another active SCSI device such as hard drives.

- 1 Is the tape drive attached to an LVD SCSI controller? This can be determined by viewing the boot process of the system and looking to see what controller the tape drive is attached to. There may be boot log files that can be examined to determine what SCSI controller the tape drive is attached to.
- 2 If the tape drive is not attached to an LVD SCSI controller, attach the tape drive to a LVD SCSI controller to achieve best possible hardware performance for best possible transfer rate.
- 3 If the tape drive is attached to an LVD SCSI controller, see whether the tape drive is the only device on the SCSI cable? This can be determined by viewing Windows Device Manager, viewing Unix/Linux logs, or by viewing SCSI controller during system boot up.
- 4 If other SCSI devices are attached to the SCSI controller and are active during the time when a backup is performed to the tape drive, have the tape drive as the only device on the SCSI cable to achieve the best possible backup performance.

The method of performing the backups can also be a factor in “slow” backups. Data sent to the tape drive over a network connection and delays in data transfer over a network connection can cause backups to slow down.

- 1 Perform write/read test with diagnostic software. This ensures a test of the connection between the tape drive and SCSI controller and removes the network data transfer and the backup software from the diagnosis. The write/read test **will overwrite data on the tape.**
- 2 When the test finishes, determine the megabyte per second data transfer. The resulting calculation shows the tape drive performing at an acceptable rate.
- 3 If you believe that the write/read transfer is slow even after using the diagnostic software write/read test, use the Quantum Tape Diagnostic software to perform a trace buffer retrieval. Send the file to Customer Support, so that the state of the SCSI bus can be determined.
- 4 If the diagnostic write/read test transfer rate is acceptable, but backups still seem to be “slow,” it may be attributed to the number of files and the average file sizes that are to be backed up. These factors can have a significant effect on the backup performance. Backups where the average file size is less than 200 Kbytes are slower than backups where the average file size is greater than 200 Kbytes. Obtain backup log files to determine number of files and average file size.

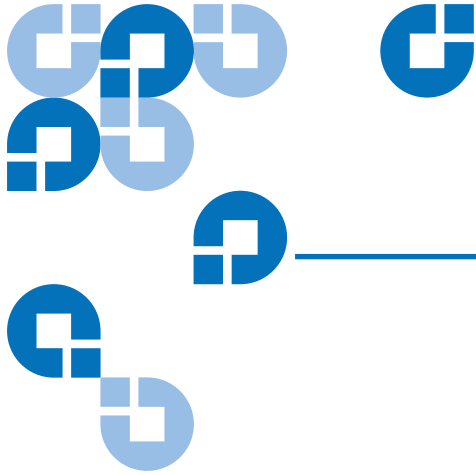

Index

A

AIX 4.1 settings 58

B

Backup/restore problems 75

Best practices 67

blink codes 25

C

Cartridges

care and maintenance 28

ejecting 75

loading 26

specifications 47

troubleshooting 72

unloading 26

write-protecting 27, 77

Checking SCSI termination

desktop drive 20

internal drive 15

Cleaning a tape drive 29

Computer boots but does not
recognize tape drive 69

Computer will not boot 69

Configuring

internal drive 8

Connecting

power cable

desktop drive 21

internal drive 18

SCSI cable for desktop drive 19

SCSI cable for internal drive 14

serial cable for internal drive 16

D

Data buffer 33

Data compression

considerations 36

- intelligent 37
- Data integrity 33
 - error-correction code 34
 - servo-tracking faults 35
- DEC/Compaq Unix settings 54
- Desktop drive
 - checking SCSI termination 20
 - connecting a power cable 21
 - connecting a SCSI cable 19
 - installation instructions 18
 - installing the LTO driver 21
 - quick start 5
 - SCSI ID 19
- Drive
 - overview xi
- Drive maintenance
 - cleaning a tape drive 29
 - parking a tape drive 30
- Drive performance specifications 43

E

- Ejecting a cartridge 75
- Electromagnetic compatibility 50
- Emergency cartridge eject 75
- Emergency reset 75
- Environmental requirements 44
- Error-correction code 34
- External drive
 - quick start 5

F

- Features 2
- Front panel display 24

G

- Guidelines, internal drive 5

H

- HP-UX 11.0 settings 64

I

- IBM AIX 4.1.x and later settings 58
- Injected noise 45
- Inspection 3
- Installation instructions
 - desktop drive
 - checking SCSI termination 20
 - connecting a power cable 21
 - connecting a SCSI cable 19
 - installing the LTO driver 21
 - overview 18
 - setting the SCSI ID 19
 - internal drive
 - checking SCSI termination 15
 - configuration 8
 - connecting a power cable 18
 - connecting a SCSI cable 14
 - connecting a serial cable 16
 - installing the LTO driver 18
 - mounting instructions 11
 - overview 8
- Installing the LTO driver
 - desktop drive 21
 - internal drive 18
- Intelligent data compression 37
- Internal drive
 - checking SCSI termination 15
 - configuring 8

- connecting a power cable 18
- connecting a SCSI cable 14
- connecting a serial cable 16
- guidelines and cautions 5
- installation instructions 8
- installing the LTO driver 18
- mounting 11
- quick start 4
- SCSI ID 8
- terminator power 10

L

- Layout of track 31
- Linux settings 61
- Loading a cartridge 26
- LTO-3
 - features 2

M

- Mean time between failures 46
- Method of recording 33
- Mounting
 - internal drive 11

O

- Overview xi

P

- Parking a tape drive 30
- Physical specifications 40

- Power cable connection
 - desktop drive 21
 - internal drive 18
- Power specifications 42

Q

- Quick start
 - desktop drive 5
 - external drive 5
 - internal drive 4

R

- Recording method 33
- Registering tape drive 18, 21
- Regulatory compliance 48
- Reliability 45
- Reset, emergency 75

S

- SCO Open Server 5.0.x Unix settings 59
- SCSI cable connection
 - desktop drive 19
 - internal drive 14
- SCSI controllers 54
- SCSI ID
 - desktop drive 19
 - internal drive 8
- SCSI II specification xiii
- Serial cable connection
 - internal drive 16
- Servo-tracking faults 35
- SGI Irix settings 63

Slow backups 79
Specifications
 drive performance 43
 electromagnetic compatibility 50
 environmental requirements 44
 injected noise 45
 LTO cartridge 47
 mean time between failures 46
 physical 40
 power 42
 regulatory compliance 48
 reliability 45
Sun (Solaris 2.4, 2.5, 2.6, 7, 8, 9) Unix settings 55

T

Tape drive
 cleaning 29
 parking 30
 registering 18, 21
 troubleshooting 72
Tape drive not recognized by operating system or application 71
Tape will not eject from drive 74
TapeAlert messages 77
Terminator power
 internal drive 10
Track layout 31
Troubleshooting 69
 backup/restore problems 75
 Computer boots but does not recognize tape drive 69
 computer will not boot 69
 slow backups 79
 tape drive not recognized by operating system or application 71
 tape drives and cartridges 72

tape will not eject from drive 74
tapeAlert messages 77

U

Unix settings
 DEC/Compaq Unix 54
 SCO Open Server 5.0.x 59
 Sun (Solaris 2.4, 2.5, 2.6, 7, 8, 9) 55
Unloading a cartridge 26
Unpacking 3

W

Write-protecting a cartridge 27, 77

Free Manuals Download Website

<http://myh66.com>

<http://usermanuals.us>

<http://www.somanuals.com>

<http://www.4manuals.cc>

<http://www.manual-lib.com>

<http://www.404manual.com>

<http://www.luxmanual.com>

<http://aubethermostatmanual.com>

Golf course search by state

<http://golfingnear.com>

Email search by domain

<http://emailbydomain.com>

Auto manuals search

<http://auto.somanuals.com>

TV manuals search

<http://tv.somanuals.com>