

TROUBLE SHOOTING

The screen is blank	<ul style="list-style-type: none">• Check that the camera is powered up.• Check that the monitor is powered up.• Check that the video cable connecting the camera to the monitor is connected properly.
The screen image is dim	<ul style="list-style-type: none">• Clean the lens (using a soft, clean cloth).• Check that the light source is adequate.
The screen image has poor contrast	<ul style="list-style-type: none">• Adjust the monitor's contrast knob.• Change the position of the camera.
The screen image flickers	<ul style="list-style-type: none">• Change the position of the camera.
The screen image is distorted	<ul style="list-style-type: none">• Change the position of the camera.
The camera case is hot	<ul style="list-style-type: none">• Check that the correct power supply is in use.

IMPORTANT Users and installers of this product are responsible for ensuring this product complies with all national, state, and local laws and statutes related to monitoring and recording audio and video signals. **SECO-LARM** will not be held responsible for the use of this product in violation of any current laws or statutes.

WARNING Stop using the camera if you see a malfunction like smoke or unusual heat, as it could cause fire or electric shock. Do not open the case of this device, as there are no field-serviceable components inside.

FCC COMPLIANCE STATEMENT Information to the user: This equipment has been tested and found to comply with the limits for a Class B digital device, pursuant to Part 15 of the FCC rules. These limits are designed to provide reasonable protection against harmful interference when the equipment is operated in a commercial environment. This equipment generates, uses and can radiate radio frequency energy and, if not installed and used in accordance with the instruction manual, may cause harmful interference to radio communications. Operation of this equipment in a residential area is likely to cause harmful interference in which case the user will be required to correct the interference at his own expense.

WARRANTY This SECO-LARM product is warranted against defects in material and workmanship while used in normal service for a period of one (1) year from the date of sale to the original consumer customer. SECO-LARM's obligation is limited to the repair or replacement of any defective part if the unit is returned, transportation prepaid, to SECO-LARM. This Warranty is void if damage is caused by or attributed to acts of God, physical or electrical misuse or abuse, neglect, repair, or alteration, improper or abnormal usage, or faulty installation, or if for any other reason SECO-LARM determines that such equipment is not operating properly as a result of causes other than defects in material and workmanship. The sole obligation of SECO-LARM, and the purchaser's exclusive remedy, shall be limited to replacement or repair only, at SECO-LARM's option. In no event shall SECO-LARM be liable for any special, collateral, incidental, or consequential personal or property damages of any kind to the purchaser or anyone else.

NOTICE

The information and specifications printed in this manual are current at the time of publication. However, the SECO-LARM policy is one of continual development and improvement. For this reason, SECO-LARM reserves the right to change specifications without notice. SECO-LARM is also not responsible for misprints or typographical errors.

Copyright © 2010 SECO-LARM U.S.A., Inc. All rights reserved. This material may not be reproduced or copied, in whole or in part, without the written permission of SECO-LARM.

SECO-LARM U.S.A., Inc.

16842 Millikan Avenue, Irvine, CA 92606

Tel: 800-662-0800 / 949-261-2999 Fax: 949-261-7326

Website: www.seco-larm.com

E-mail: sales@seco-larm.com

PICSN4

MIEV-122C-DXB3Q_0914b.pmd

SECO-LARM

EV-122C-DXB3Q

Multi-Axis Ball-Mount Color Dome Camera

MANUAL



- Multi-Axis ball mount for wall or ceiling mounting
- 360° Rotation, 10°~120° tilt
- 1/3" Sony Super HAD II CCD
- 3.6mm Lens
- 24 IR LEDs
- 50ft (15m) IR range
- Concealed wiring

Note: Products with model number that ends with "Q" or have a round green "Q" sticker represents RoHS compliant products.

Specifications

EV-122C-DXB3Q (NTSC)

Type	Color camera
Chip	1/3" Sony Super HAD II CCD
Resolution	420 TV lines
Pickup elements	510x492 pixels
Scanning system	2:1 interlace, V: 60Hz, H: 15.734KHz
Sync	Internal
Video output	1.0Vp-p composite output, 75 ohms
Lens	F1 2, 3.6 mm (lens included)
IR LEDs	24
IR distance	Up to 50 ft. (15 m)
IR view angle	50°~80° Beam spread, 30° per LED
Minimum illumination	0.05 lux, (0 lux with IR on)
Gamma correction	0.45
S/N ratio	> 50dB
Shutter control	Auto Electronic Shutter (AES) 1/60~1/100,000 sec. (NTSC)
Automatic gain control	Auto
White balance	Auto, 2500°~9500°K
Power source	12 VDC ± 10%
Power consumption	70 mA LEDs off, 200 mA LEDs on
Storage temperature	-4°~122° F (-20°~50° C)
Operating temperature	14°~122° F (-10°~50° C)
Dimensions	3 ^{11/16} " x 2 ^{11/16} " (93 x 69 mm)
Weight	6 oz. (170 g)

Dimensions:

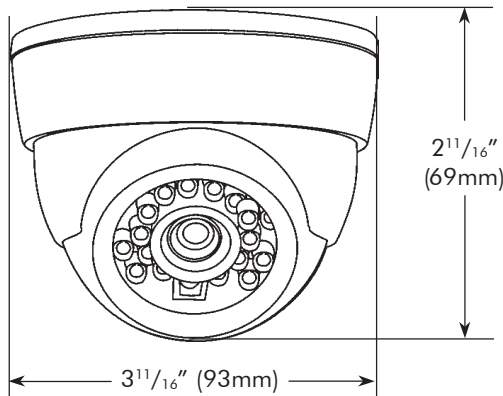

Parts List

- 1 x Camera Ball
- 1 x Case (2-part construction)
- 1 x Base
- 3 x Screws
- 1 x Manual
- 1 x DC plug with terminal block

CA-161T - DC plug included.

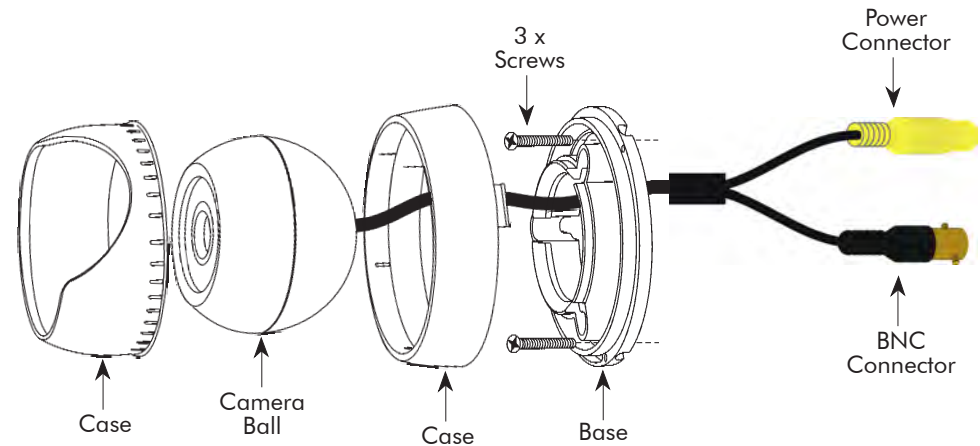

BEFORE STARTING

1. Please read this manual carefully and keep it for future reference.
 2. Use the camera within given temperature and electrical limits.
 3. Do not mount the camera where it is exposed to rain or other moisture, or in humid or dusty places.
 4. Do not point the camera at the sun. Heat could damage the camera, even when not in use.
 5. Do not mount the camera in areas exposed to radiation, strong magnetic fields, or strong electrical signals.*
 6. Do not open or disassemble the camera. There are no user-serviceable parts inside.
 7. Do not drop the camera or subject it to strong vibrations.
- * Note: Many video monitors produce strong electromagnetic fields close to the display CRT, especially when the monitor is turned on or during de-Gaussing, which occurs automatically with many monitors when the monitor is turned on.

INSTALLATION

1. Run a 12VDC power supply wire and a video cable with a male BNC connector through the wall to where the camera is to be mounted.
 2. Temporarily connect the camera to the 12VDC power supply.
 3. Temporarily connect the camera's female BNC connector to the video cable's male BNC connector.
 4. While watching the monitor, hold the camera against the wall by hand where it is to be mounted, then turn the camera until it is certain that this mounting location is correct. Use a pencil to mark the location of the three screw holes in the base.
 5. Disconnect the 12VDC power supply and video cable.
 6. Mount the bracket to the wall using the three included mounting screws. If the wall is made of dry wall, brick, or similar material, it may be necessary to use screw anchors (not included).
 7. Reconnect the 12VDC power supply and video cable. Turn the monitor on, and make sure the camera is sending the proper video signal.
 8. Adjust the camera angle.
 9. Put the case over the camera ball and twist to secure to the base.
 10. Do a final test of the video camera and monitor.
- * Note: The base also allows flush-mounting of the camera. However, for the best security, run the wires through the wall.

Free Manuals Download Website

<http://myh66.com>

<http://usermanuals.us>

<http://www.somanuals.com>

<http://www.4manuals.cc>

<http://www.manual-lib.com>

<http://www.404manual.com>

<http://www.luxmanual.com>

<http://aubethermostatmanual.com>

Golf course search by state

<http://golfingnear.com>

Email search by domain

<http://emailbydomain.com>

Auto manuals search

<http://auto.somanuals.com>

TV manuals search

<http://tv.somanuals.com>